

A UK Atom Interferometer Observatory and Network

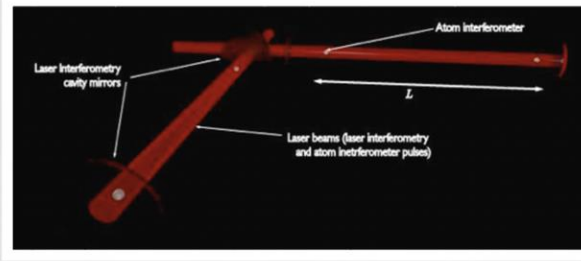

MIGA: Terrestrial detector using atom interferometer at O(100m)
(France)



ZAIGA: Terrestrial detector for large scale atomic interferometers, gyros and clocks at O(100m)
(China)

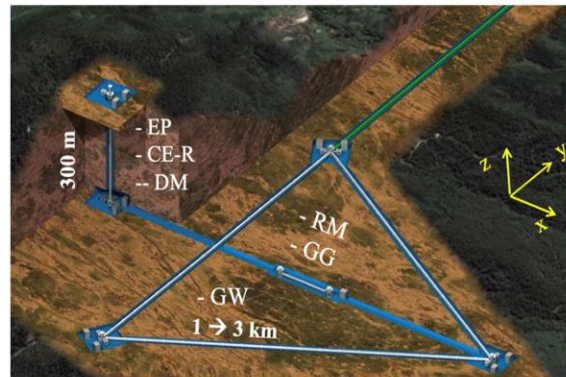

VLBAI: Terrestrial tower using atom interferometer O(10m)
(Germany)

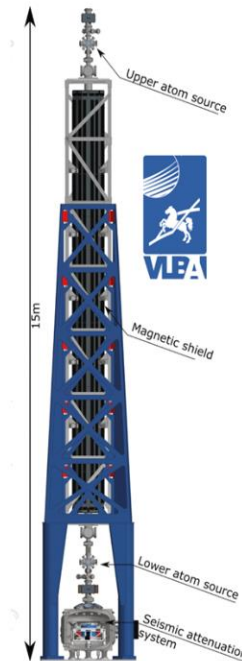

AION: Terrestrial shaft detector using atom interferometer at 10m
- O(100m) planned
(UK)

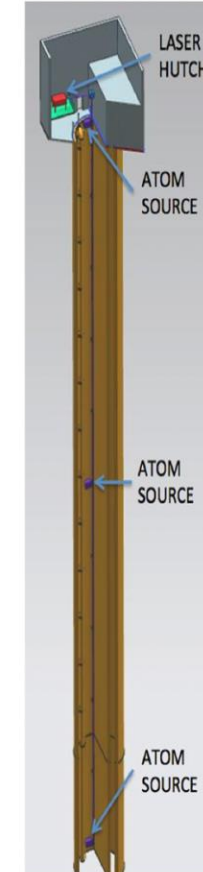

MAGIS: Terrestrial shaft detector using atom interferometer at O(100m)
(US)

Planned network operation

Oliver Buchmueller,

Imperial College London, Oxford University, Royal Society Leverhulme Trust Senior Research Fellow

LARGE SCALE ATOM INTERFEROMETRY TO EXPLORE FUNDAMENTAL PHYSICS

Light vs. Cold Atoms: Atom Interferometry

Light interferometer

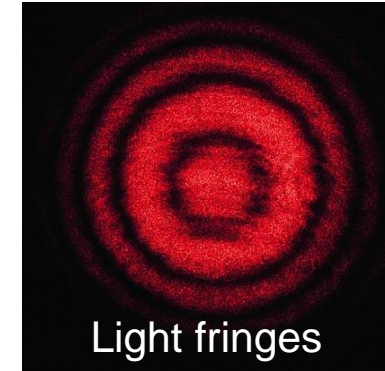
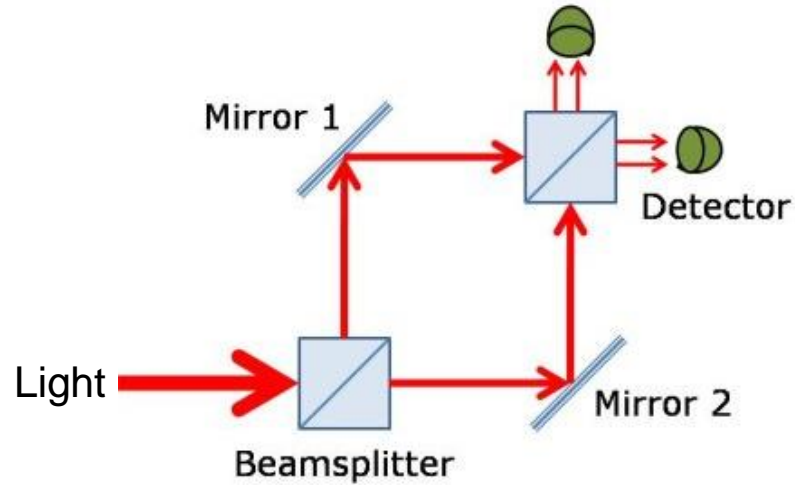

Atom interferometer

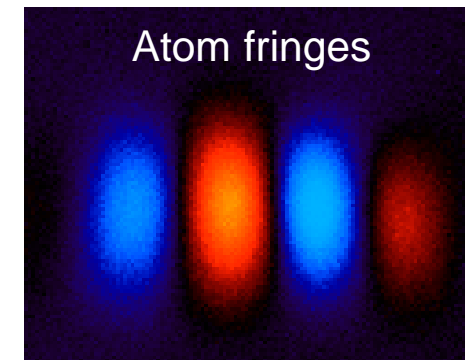
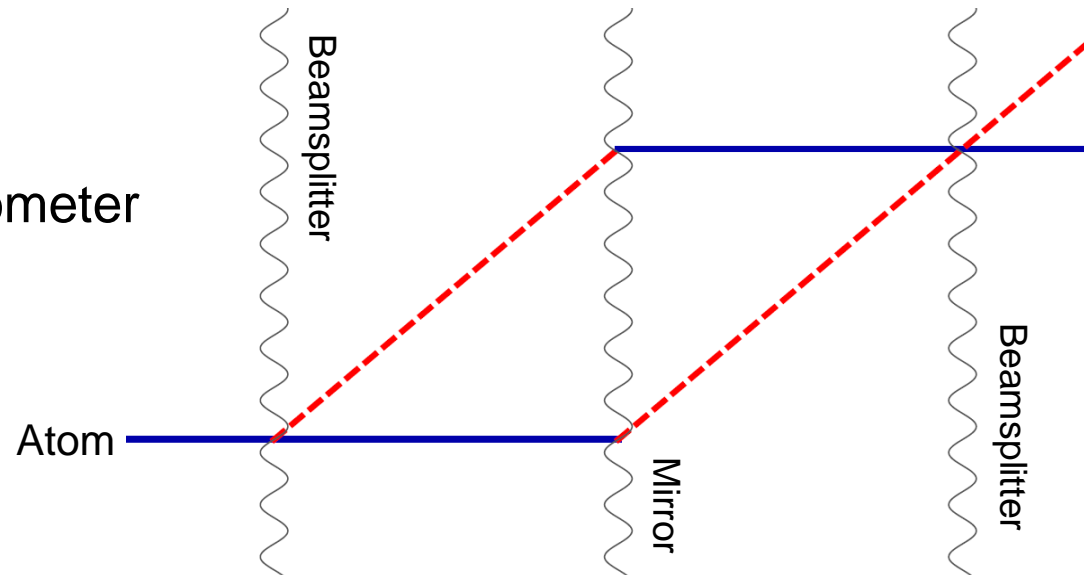

Simple Example: Two Atomic Clocks

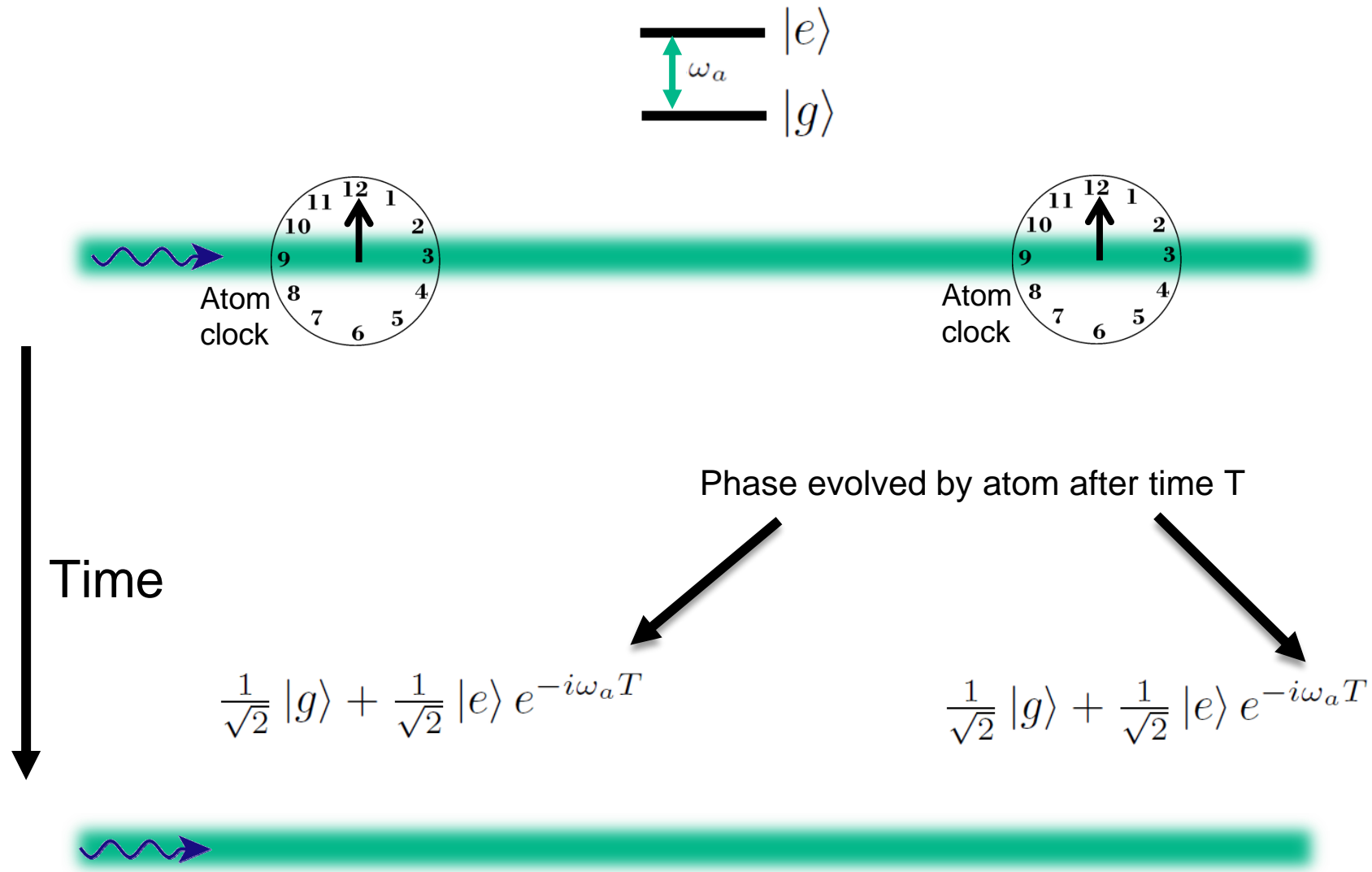

Simple Example: Two Atomic Clocks

$$\frac{1}{\sqrt{2}} |g\rangle + \frac{1}{\sqrt{2}} |e\rangle$$
$$\frac{1}{\sqrt{2}} |g\rangle + \frac{1}{\sqrt{2}} |e\rangle$$



Time

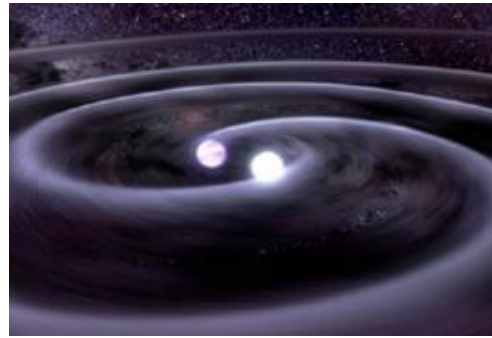

**GW changes
light travel time**

$$\Delta T \sim hL/c$$

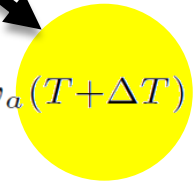

$$\frac{1}{\sqrt{2}} |g\rangle + \frac{1}{\sqrt{2}} |e\rangle e^{-i\omega_a T}$$

$$\frac{1}{\sqrt{2}} |g\rangle + \frac{1}{\sqrt{2}} |e\rangle e^{-i\omega_a (T+\Delta T)}$$

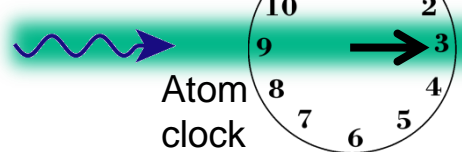

Atom
clock

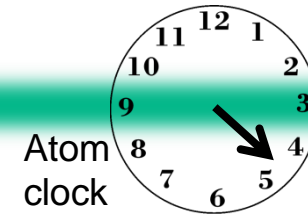

Atom
clock

Simple Example: Two Atomic Clocks

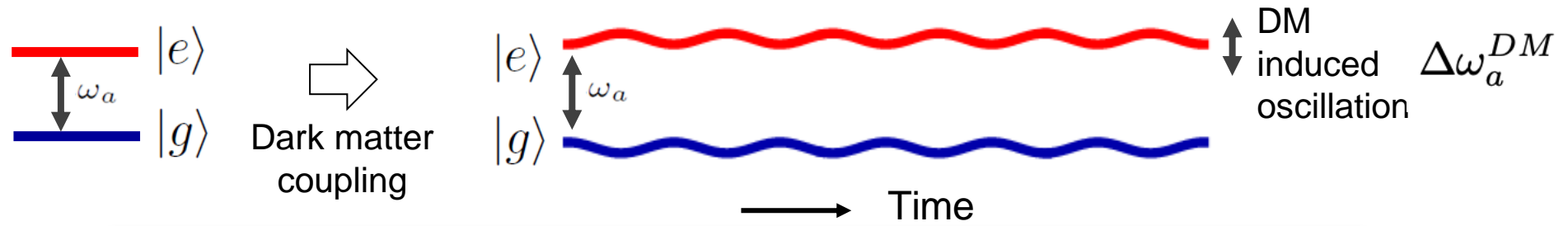

Time

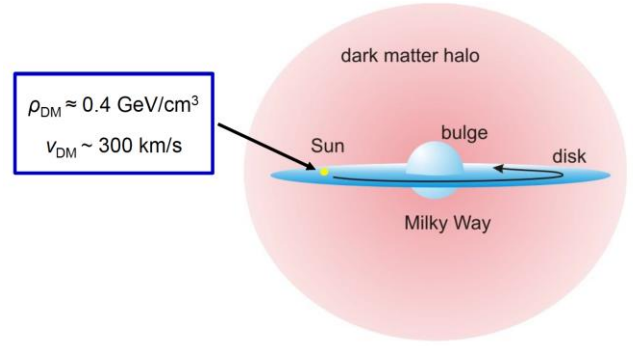

DM cloud changes atom frequency

DM coupling causes time-varying atomic energy levels:

$$\frac{1}{\sqrt{2}} |g\rangle + \frac{1}{\sqrt{2}} |e\rangle e^{-i\omega_a T}$$

$$\frac{1}{\sqrt{2}} |g\rangle + \frac{1}{\sqrt{2}} |e\rangle e^{-i(\omega_a + \Delta\omega_a^{DM})T}$$

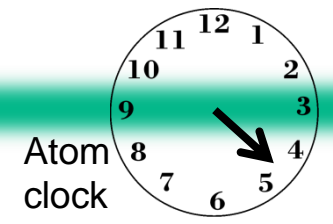
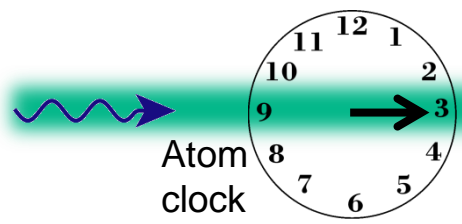

Large Scale AI For Fundamental Physics

AION Project in the UK

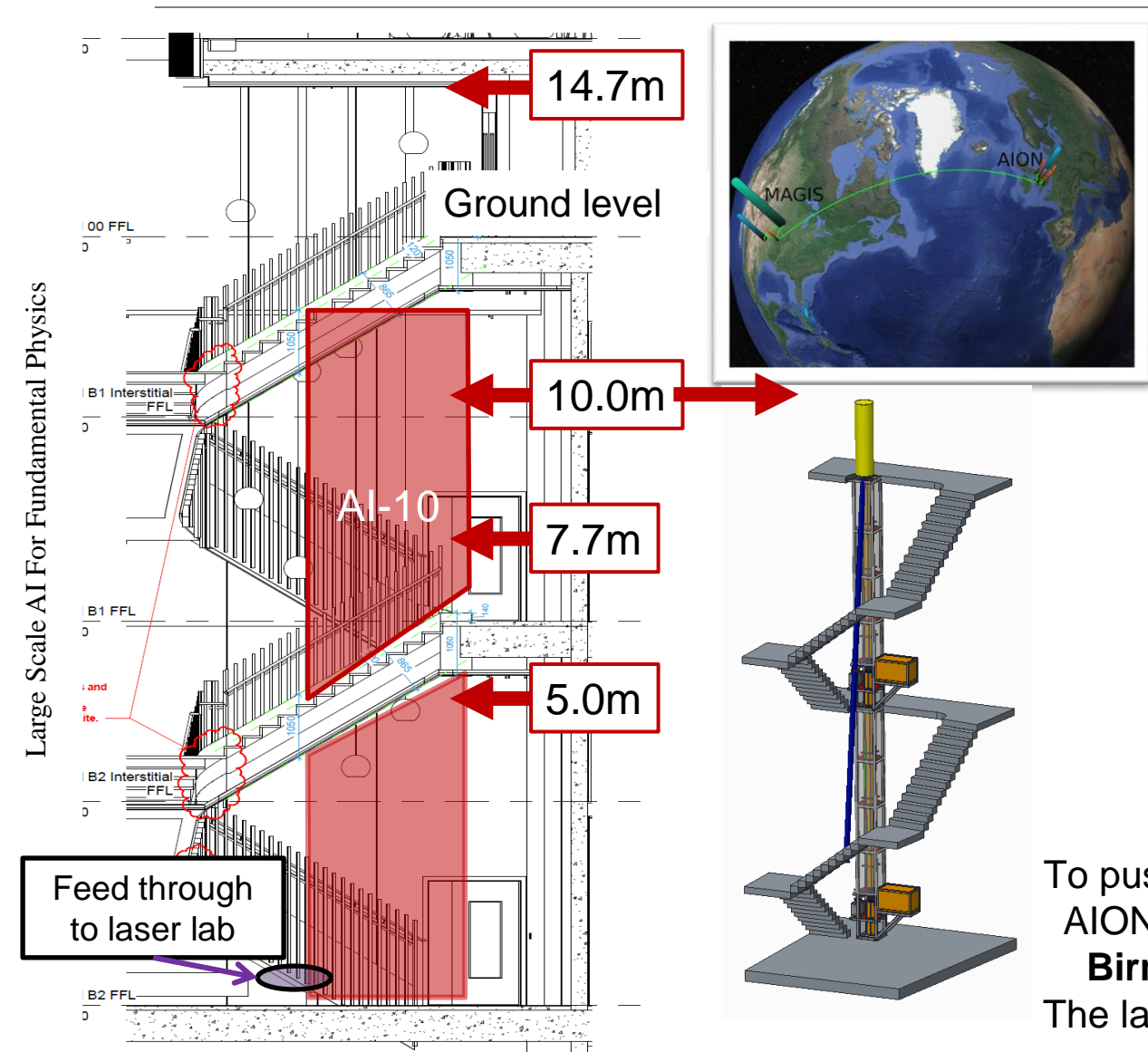

Project executed in national partnership with **UK National Quantum Technology Hub in Sensors and Timing, Birmingham, UK**, and international partnership with **The MAGIS Collaboration and The Fermi National Laboratory, US**

To push the state-of-the-art single photon Sr Atom Interferometry, the AION project builds dedicated Ultra-Cold Strontium Laboratories in: **Birmingham, Cambridge, Imperial College, Oxford, and RAL**. The laboratories are expected to be fully operational in summer 2023.

L. Badurina et al., *AION: An Atom Interferometer Observatory and Network*, JCAP **05** (2020) 011, [arXiv:1911.11755]

The AION Programme consists of 4 Stages

❑ **Stage 1:** to build and commission the 10 m detector, develop existing technology and the infrastructure for the 100 m.

L ~ 10m

❑ **Stage 2:** to build, commission and exploit the 100 m detector and carry out a design study for the km-scale detector.

L ~ 100m

- AION was selected in 2018 by STFC as a high-priority medium-scale project.
- AION will work in equal partnership with MAGIS in the US to form a “LIGO/Virgo-style” network & collaboration, providing a pathway for UK leadership.

Stage 1 is now funded with about £10M by the QTFP Programme and other sources and Stage 2 could be placed at national facility in Boulby or Daresbury (UK), possibly also at CERN (France/Switzerland).

❑ **Stage 3:** to build a kilometre-scale terrestrial detector.

L ~ 1km

❑ **Stage 4:** long-term objective a pair of satellite detectors (thousands of kilometres scale) [AEDGE proposal to ESA Voyage2050 call]

- AION has established science leadership in AEDGE, bringing together collaborators from European and Chinese groups (e.g. MIGA, MAGIA, ELGAR, ZAIGA).

Stage 3 and 4 will likely require funding on international level (ESA, EU, etc) and AION has already started to build the foundation for it.

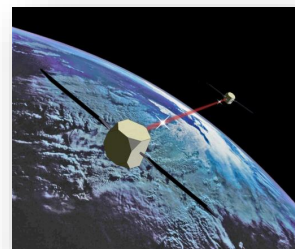
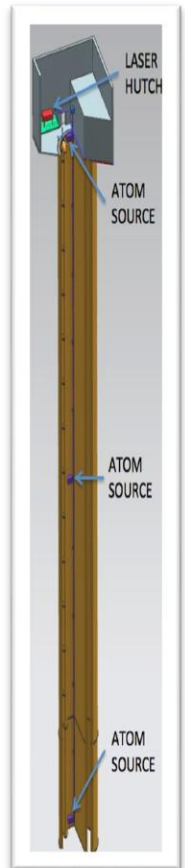

Ground Based Large Scale O(100m) Projects

MIGA: Terrestrial detector using atom interferometer at O(100m)
(France)

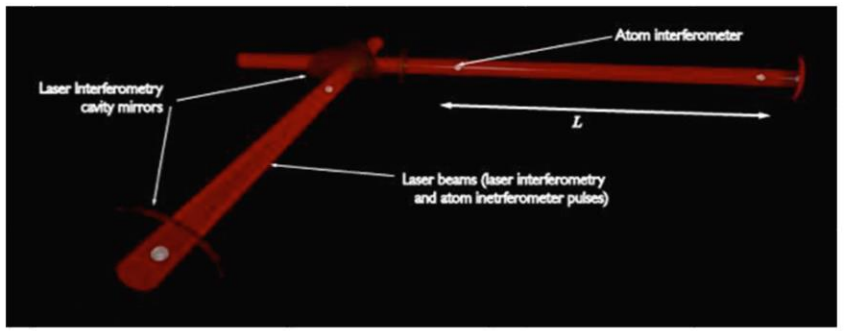

ZAIGA: Terrestrial detector for large scale atomic interferometers, gyros and clocks at O(100m)
(China)

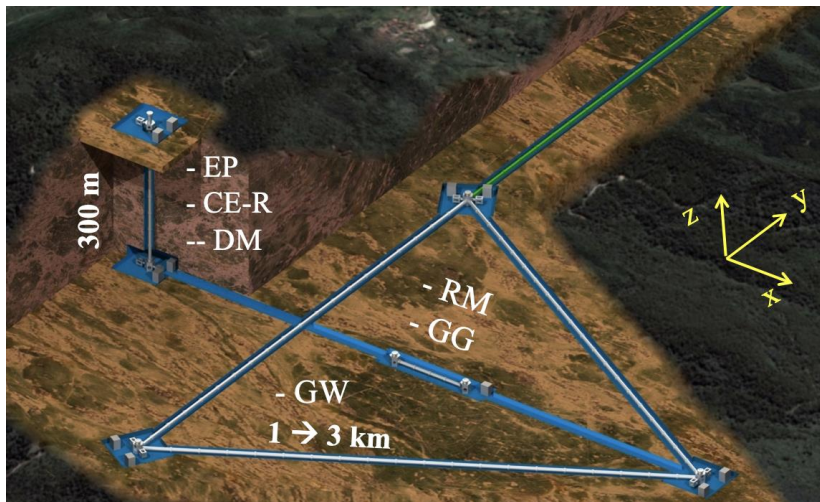

VLBAI: Terrestrial tower using atom interferometer O(10m)
(Germany)

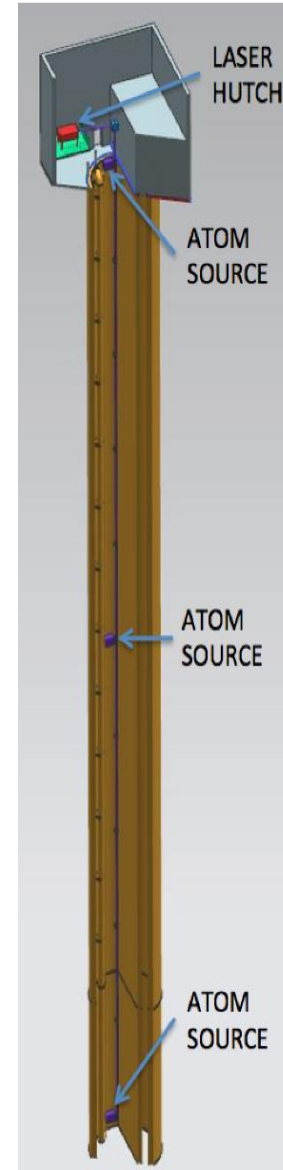
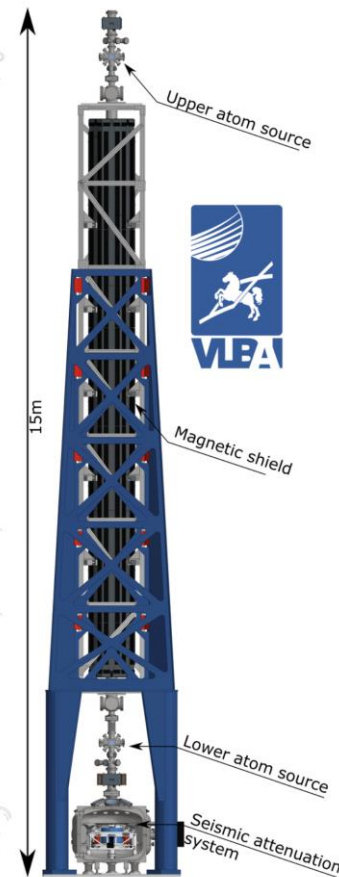

AION: Terrestrial shaft detector using atom interferometer at 10m – O(100m) planned
(UK)



MAGIS: Terrestrial shaft detector using atom interferometer at O(100m)
(US)

Planned network operation

Ground Based Large Scale O(100m) Projects

MIGA: Terrestrial detector using atom interferometer at O(100m)
(France)

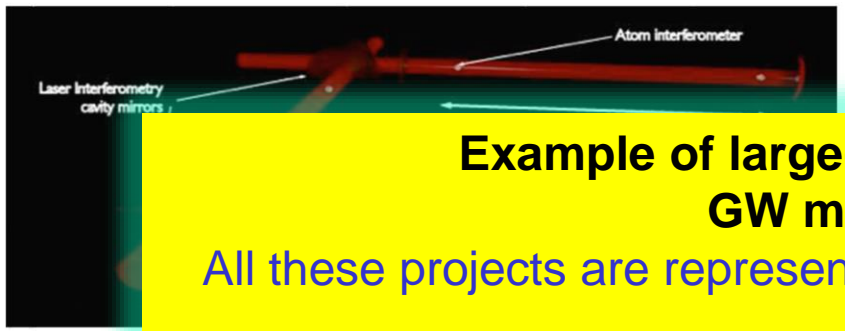

VLBAI: Terrestrial tower using atom interferometer O(10m)

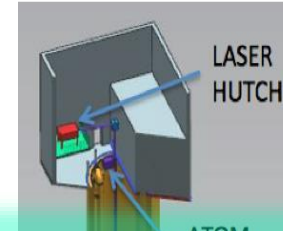

AION: Terrestrial shaft detector using atom interferometer at 10m – O(100m) planned
(UK)

Example of large-scale CA projects that act as demonstrators for GW mid-frequency band and DM detectors.
All these projects are represented in the AEDGE consortium and now are also part of the Cold Atoms in Space Community.

ZIGA: interf

Each project requires an investment of O(10M) currency units.
All projects (AION, MAGIS, MIGA, VLBAI, ZIGA) are funded by national funding agencies and foundations.

Timeline 2020 to 2025ish

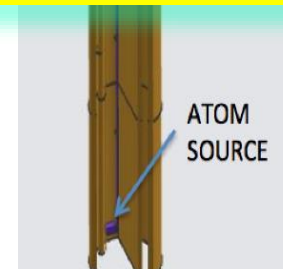
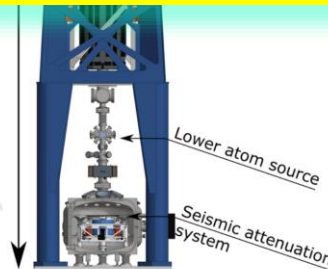
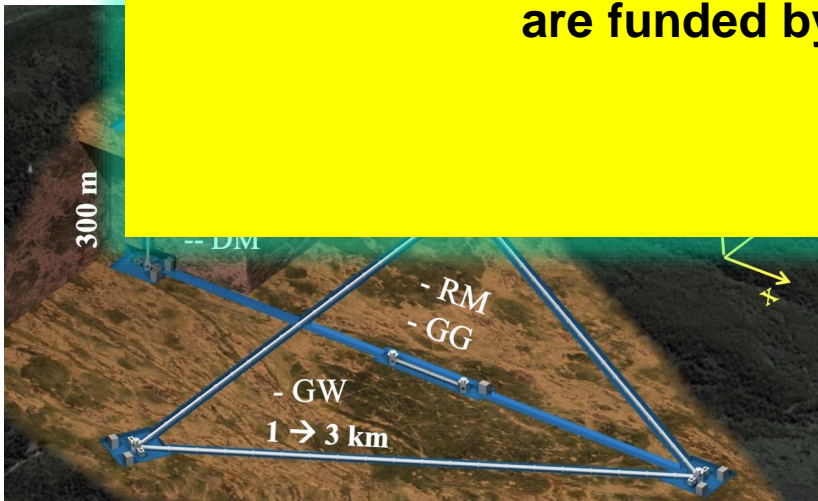

MAGIS: Terrestrial shaft detector using atom interferometer at O(100m)
(US)

Planned network operation

Large Scale AI For Fundamental Physics

Terrestrial Very-Long-Baseline Atom Interferometry

WORKSHOP



The event will take stock of the developing international landscape of large-scale Atom Interferometer prototypes and discuss their synergies and complementarity. Such devices will be able to detect ultralight dark matter and gravitational waves in the mid-frequency band, complementing the capabilities of optical interferometers on Earth and the future LISA space mission, and offering unique sensitivity to ultralight bosonic dark matter.

Organisers:

INTERNATIONAL ORGANISATION COMMITTEE

Kai Bongs, University of Birmingham, UK
Philippe Bouyer, CNRS, Institut d'Optique, France
Oliver Buchmueller, Imperial College London, UK
Benjamin Canuel, CNRS, Institut d'Optique, France
Marilù Chiofalo, University of Pisa and INFN Pisa, Italy
John Ellis, King's College London, UK
Naceur Gaaloul, Leibniz Universität Hannover, Germany
Jason Hogan, Stanford University, US
Timothy Kovachy, Northwestern University
Ernst Rasel, Leibniz Universität Hannover, Germany
Guglielmo Tino, Università di Firenze and LENS, Italy
Wolf von Klitzing, IESL-FORTH, Greece
Mingsheng Zhan, Wuhan Institute of Physics and Mathematics, China

LOCAL ORGANISATION COMMITTEE

Gianluigi Arduini, CERN, Geneva, Switzerland
Sergio Calatroni, CERN, Geneva, Switzerland
Albert De Roeck, CERN, Geneva, Switzerland, and University of Antwerp, Belgium
Michael Doser, CERN, Geneva, Switzerland
Elina Fuchs, CERN, Geneva, Switzerland

INFORMATION

<https://indico.cern.ch/event/1208783/>



MIGA: Terrestrial detector using atom interferometer at O(100m)

(France)

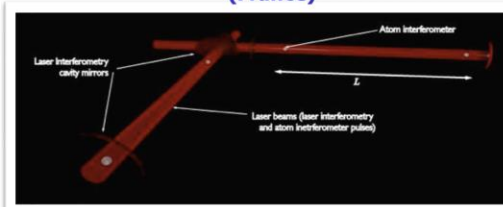

ZIGA: Terrestrial detector for large scale atomic interferometers, gyros and clocks at O(100m)

(China)

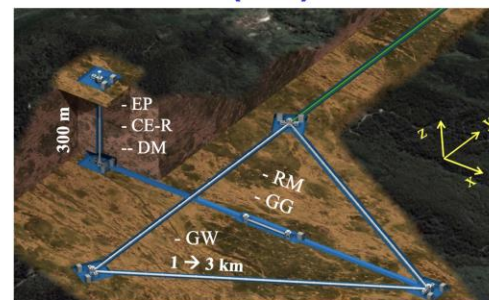

VLBAI: Terrestrial tower using atom interferometer O(10m)

(Germany)

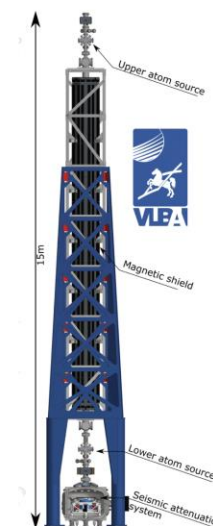

AION: Terrestrial shaft detector using atom interferometer at 10m

– O(100m) planned (UK)

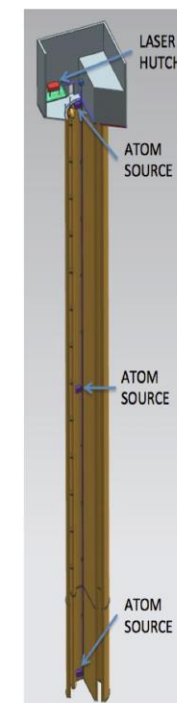

MAGIS: Terrestrial shaft detector using atom interferometer at O(100m)

(US)

Planned network operation

International Organisation Committee

Kai Bongs, University of Birmingham, UK
Philippe Bouyer, CNRS, Institut d'Optique, France
Oliver Buchmueller, Imperial College London, UK
Benjamin Canuel, CNRS, Institut d'Optique, France
Marilù Chiofalo, University of Pisa and INFN Pisa, Italy
John Ellis, King's College London, UK
Naceur Gaaloul, Leibniz Universität Hannover, Germany
Jason Hogan, Stanford University, US
Timothy Kovachy, Northwestern University
Ernst Rasel, Leibniz Universität Hannover, Germany
Guglielmo Tino, Università di Firenze and LENS, Italy
Wolf von Klitzing, IESL-FORTH, Greece
Mingsheng Zhan, Wuhan Institute of Physics and Mathematics, China

Local Organisation Committee

Gianluigi Arduini, CERN, Geneva, Switzerland
Sergio Calatroni, CERN, Geneva, Switzerland
Albert De Roeck, CERN, Geneva, Switzerland, and University of Antwerp, Belgium
Michael Doser, CERN, Geneva, Switzerland
Elina Fuchs, CERN, Geneva, Switzerland

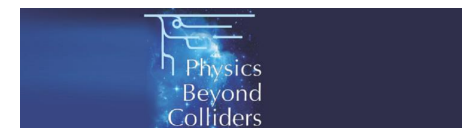

Possible site for a vertical VLBAI at CERN: 140 m deep pit at LHC Pt 4

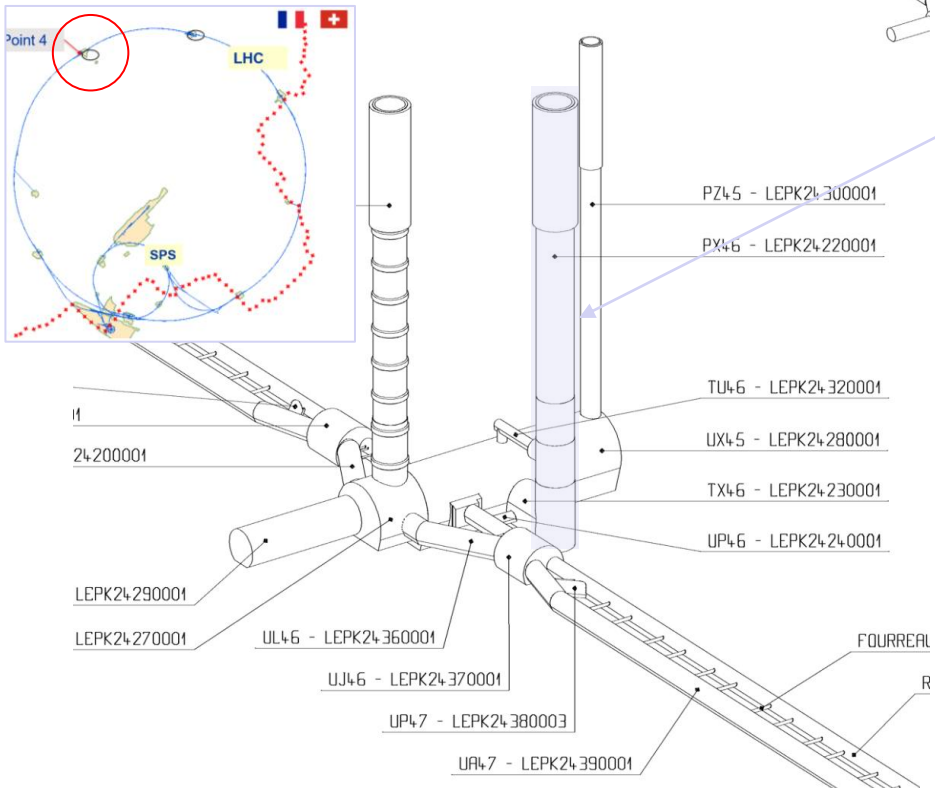

PX46 – P4 Support shaft
Depth 143m, diameter 10.10m

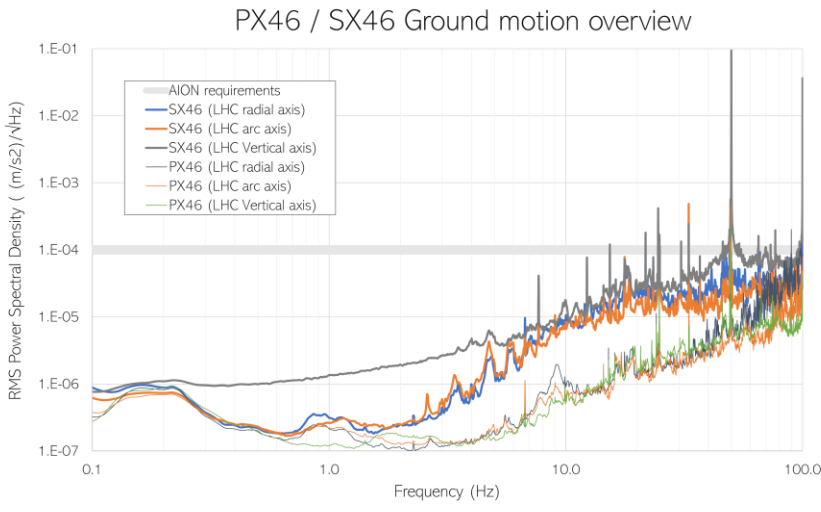

Dose equivalent – case of beam loss
 Shielding wall at the bottom of TX46

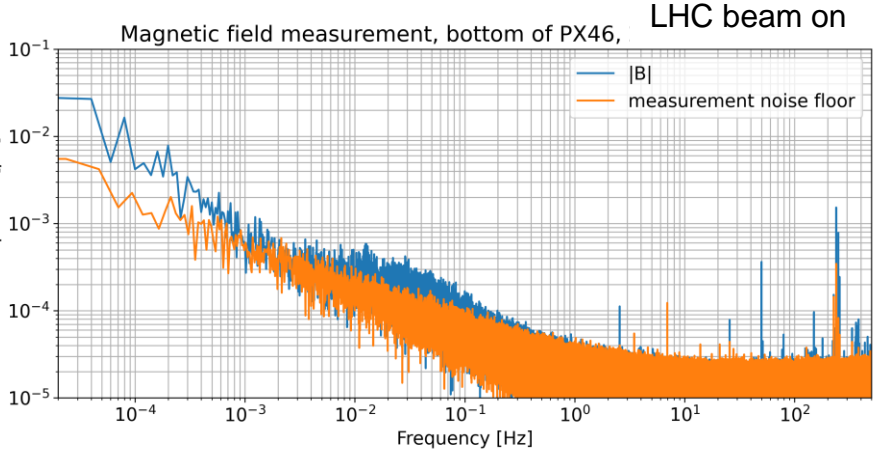
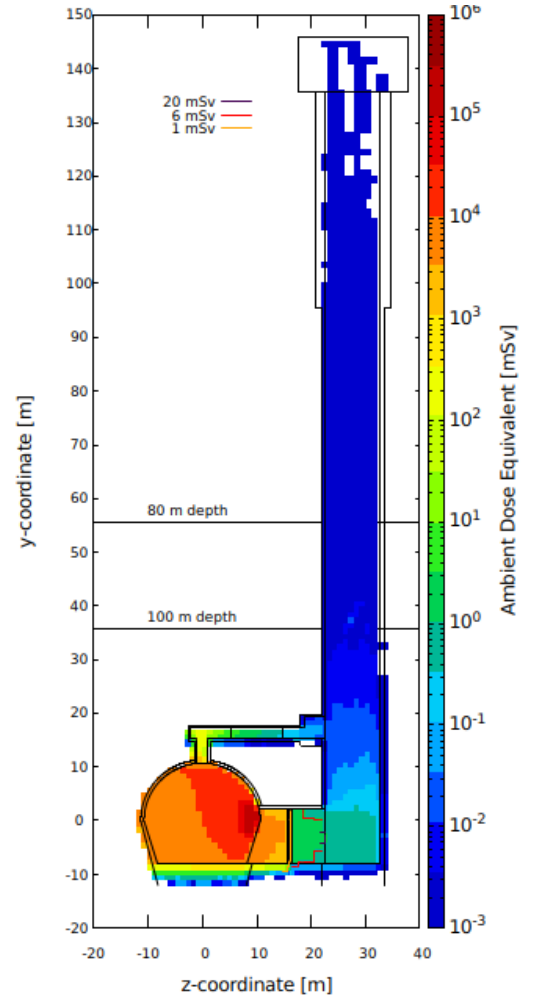

Safety, access, evacuation, etc.: demonstrated feasibility for 365d/y 24h24 access and AION operation, also when the LHC beam is on

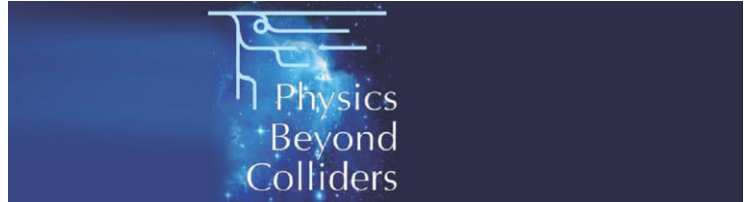

Large Scale AI For Fundamental Physics

Possible site for a vertical VLBAI at CERN pt.4

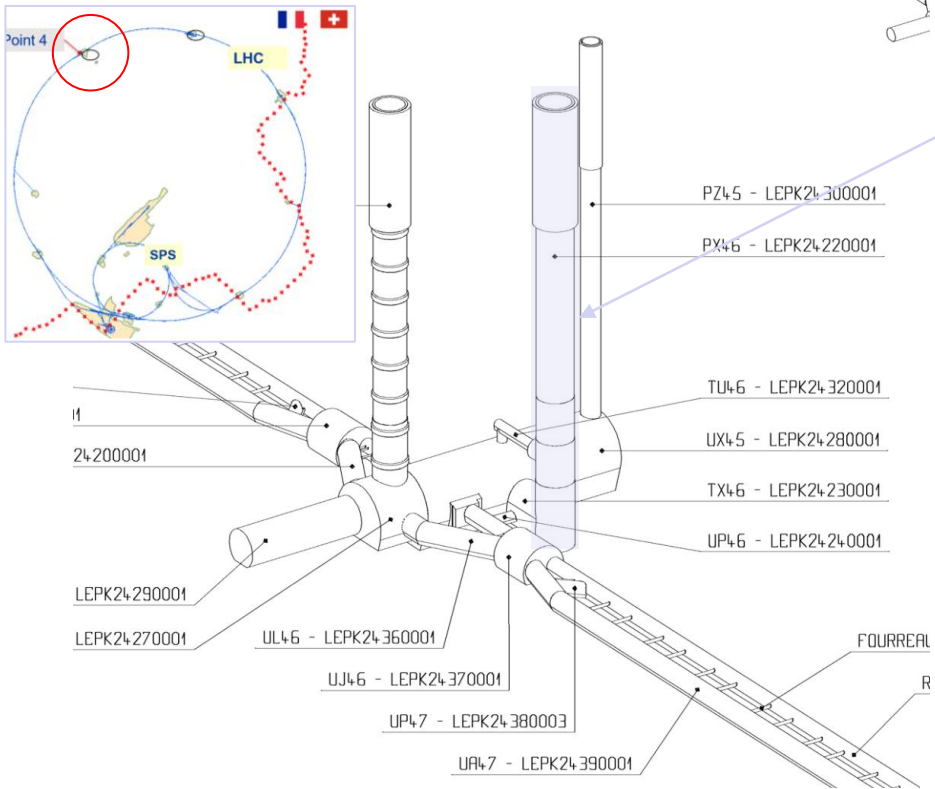

PX46 – F
Depth 143m

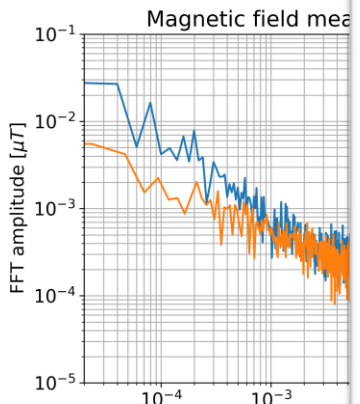
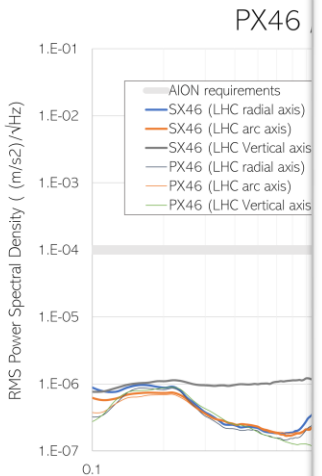

Large Scale AI For Fundamental Physics

Safety, access, evacuation, etc.: demonstrated feasibility for 365d/y 24h24 access and AION operation, also when the LHC beam is on

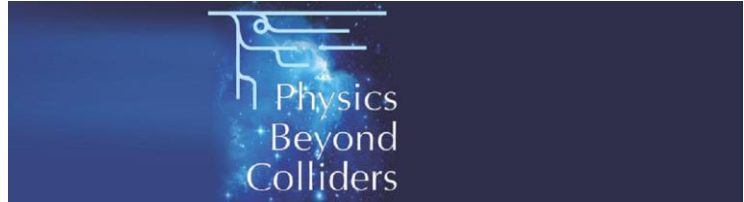

CERN-PBC Report-2023-002



A Long-Baseline Atom Interferometer at CERN: Conceptual Feasibility Study

G. Arduini^{1,*}, L. Badurina², K. Balazs¹, C. Baynham³, O. Buchmueller^{3,4,*}, M. Buzio¹, S. Calatroni^{1,*}, J.-P. Corso¹, J. Ellis^{1,2,*}, Ch. Gaignant¹, M. Guinchard¹, T. Hakulinen¹, R. Hobson³, A. Infantino¹, D. Lafarge¹, R. Langlois¹, C. Marcel¹, J. Mitchell⁵, M. Parodi¹, M. Pentella¹, D. Valuch¹, H. Vincke¹

¹ CERN, ² King's College London, ³ Imperial College London, ⁴ University of Oxford, ⁵ University of Cambridge
* Editors

Abstract

We present results from exploratory studies, supported by the Physics Beyond Colliders (PBC) Study Group, of the suitability of a CERN site and its infrastructure for hosting a vertical atom interferometer (AI) with a baseline of about 100 m. We first review the scientific motivations for such an experiment to search for ultralight dark matter and measure gravitational waves, and then outline the general technical requirements for such an atom interferometer, using the AION-100 project as an example. We present a possible CERN site in the PX46 access shaft to the Large Hadron Collider (LHC), including the motivations for this choice and a description of its infrastructure. We then assess its compliance with the technical requirements of such an experiment and what upgrades may be needed. We analyse issues related to the proximity of the LHC machine and its ancillary hardware and present a preliminary safety analysis and the required mitigation measures and infrastructure modifications. In conclusion, we identify primary cost drivers and describe constraints on the experimental installation and operation schedules arising from LHC operation. We find no technical obstacles: the CERN site is a very promising location for an AI experiment with a vertical baseline of about 100 m.

Geneva, Switzerland
August 7, 2023

am loss of TX46

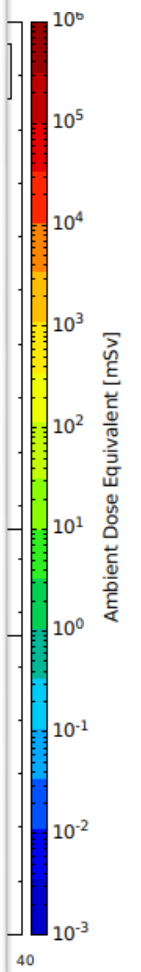

Possible site for a vertical VLBAI at CERN pt.4

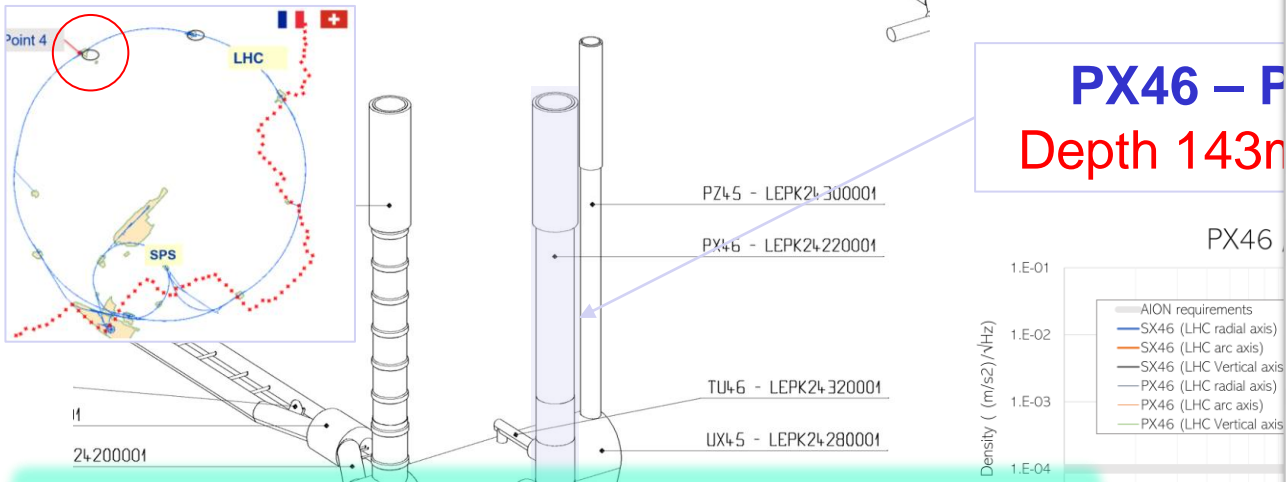

Cost Estimate for required refurbishment of shaft is rather modest!

Safety
feasibility
operation

Item	Cost [kCHF]
Shielding	400
Lifting platform	400
Access, safety systems and monitoring	200
General services and utilities	500
Total	1500

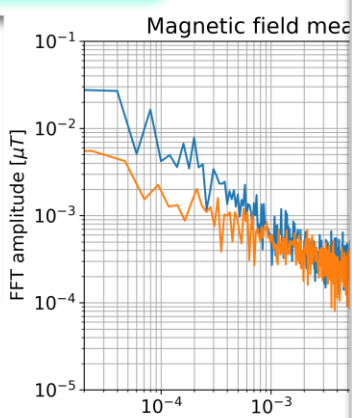
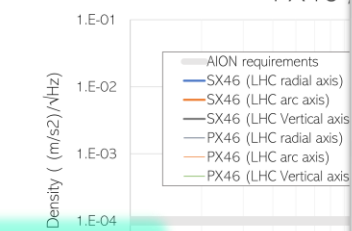

CERN-PBC Report-2023-002

A Long-Baseline Atom Interferometer at CERN: Conceptual Feasibility Study

G. Arduini^{1,*}, L. Badurina², K. Balazs¹, C. Baynham³, O. Buchmueller^{3,4,*}, M. Buzio¹, S. Calatroni^{1,*}, J.-P. Corso¹, J. Ellis^{1,2,*}, Ch. Gaignant¹, M. Guinchard¹, T. Hakulinen¹, R. Hobson³, A. Infantino¹, D. Lafarge¹, R. Langlois¹, C. Marcel¹, J. Mitchell⁵, M. Parodi¹, M. Pentella¹, D. Valuch¹, H. Vincke¹

¹ CERN, ² King's College London, ³ Imperial College London, ⁴ University of Oxford, ⁵ University of Cambridge
* Editors

Abstract

We present results from exploratory studies, supported by the Physics Beyond Colliders (PBC) Study Group, of the suitability of a CERN site and its infrastructure for hosting a vertical atom interferometer (AI) with a baseline of about 100 m. We first review the scientific motivations for such an experiment to search for ultralight dark matter and measure gravitational waves, and then outline the general technical requirements for such an atom interferometer, using the AION-100 project as an example. We present a possible CERN site in the PX46 access shaft to the Large Hadron Collider (LHC), including the motivations for this choice and a description of its infrastructure. We then assess its compliance with the technical requirements of such an experiment and what upgrades may be needed. We analyse issues related to the proximity of the LHC machine and its ancillary hardware and present a preliminary safety analysis and the required mitigation measures and infrastructure modifications. In conclusion, we identify primary cost drivers and describe constraints on the experimental installation and operation schedules arising from LHC operation. We find no technical obstacles: the CERN site is a very promising location for an AI experiment with a vertical baseline of about 100 m.

Geneva, Switzerland
August 7, 2023

am loss
of TX46

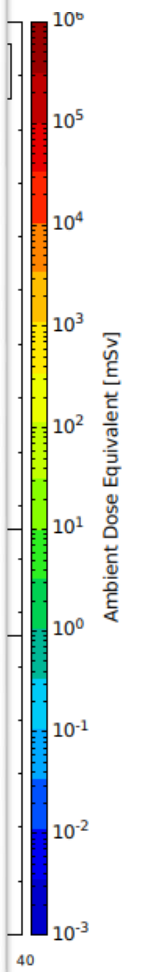

Possible GW Experimental Landscape: 2030ish

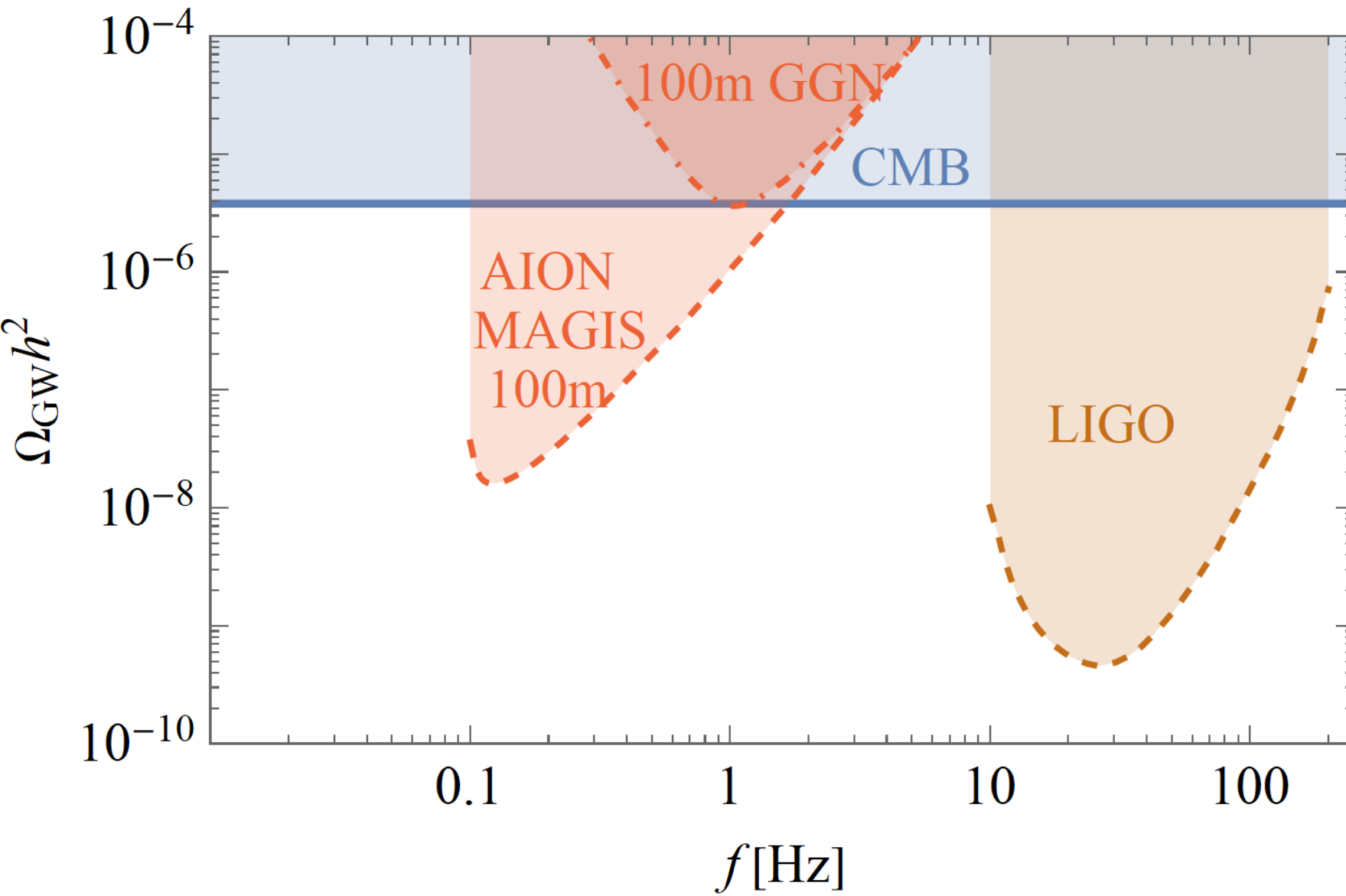

Besides probing a large range of new Ultra-Light DM parameter space, a ~100m experiment could also explore new territory for gravitational waves in a yet unexplored frequency range.

Terrestrial Very-Long-Baseline Atom Interferometry

WORKSHOP

Workshop Summary now published with more than 250 co-authors:

AVS Quantum Science (Vol. 6, Issue 2)

<https://doi.org/10.1116/5.0185291>

DOI: 10.1116/5.0185291

Jason Hogan, Stanford University, US
Timothy Kovachy, Northwestern University
Ernst Rasel, Leibniz Universität Hannover, Germany
Guglielmo Tino, Università di Firenze and LENS, Italy
Wolf von Klitzing, IESL-FORTH, Greece
Mingsheng Zhan, Wuhan Institute of Physics and Mathematics, China

LOCAL ORGANISATION COMMITTEE

Gianluigi Arduini, CERN, Geneva, Switzerland
Sergio Calatroni, CERN, Geneva, Switzerland
Albert De Roeck, CERN, Geneva, Switzerland, and University of Antwerp, Belgium
Michael Doser, CERN, Geneva, Switzerland
Elina Fuchs, CERN, Geneva, Switzerland

INFORMATION

<https://indico.cern.ch/event/1208783/>



Terrestrial Very-Long-Baseline Atom Interferometry

2nd WORKSHOP

2nd TVLBAI Workshop was held in LONDON in APRIL with the goal of forming a proto-collaboration.

The primary objectives of the workshop are to discuss the technology and physics drivers for large-scale Atom Interferometry as well as to establish the foundation for an international TVLBAI proto-collaboration. This proto-collaborative effort aims to bring together researchers from diverse institutions, fostering strategic discussions and securing funding for terrestrial large-scale Atom Interferometer projects. The goal is to develop a comprehensive roadmap outlining design choices, technological considerations, and science drivers for one or more kilometer-scale detectors, expected to become operational in the mid-2030s.

Oliver Buchmueller, Imperial College London, UK
Sergio Calatroni, CERN, Geneva, Switzerland
Benjamin Canuel, CNRS, Institut d'Optique, France
Merilo Chiofalo, University of Pisa and INFN Pisa, Italy
Michael Doser, CERN, Geneva, Switzerland
John Ellis, King's College London, UK
Naceur Gaaloul, Leibniz Universität Hannover, Germany
Jason Hogan, Stanford University, US
Peter Knight, Imperial College London, UK
Timothy Kovachy, Northwestern University, US
Ernst Rasel, Leibniz Universität Hannover, Germany
Ian Shipsey, Oxford University, UK
Guglielmo Tino, Università di Firenze and LENS, Italy
Wolf von Klitzing, IESL-FORTH, Greece
Mingsheng Zhan, Wuhan Institute of Physics and Mathematics, China

LOCAL ORGANISATION COMMITTEE

Charles Bsynham, Imperial College London, UK
Oliver Buchmueller, Imperial College London, UK
John Ellis, King's College London, UK
Richard Hobson, Imperial College London, UK
Adam Lowe, Oxford University, UK
Christopher McCabe, King's College London
Sean Pilling, Boulby Underground Laboratory, UK
Ulrich Schneider, Cambridge University, UK
Dennis Schlipfert, Leibniz University Hannover, Germany
Maurits van der Grinten, Rutherford Appleton Laboratory, UK

INFORMATION

<https://indico.cern.ch/event/1369392/>



Imperial College
London



Physics Potential

Unlocking the potential for observation of Ultra-Light Dark Matter and Gravitational Waves from cosmological and astrophysical sources in the unexplored mid-frequency band

T. Damour, C. A. M. Escar, Fundamental Physics

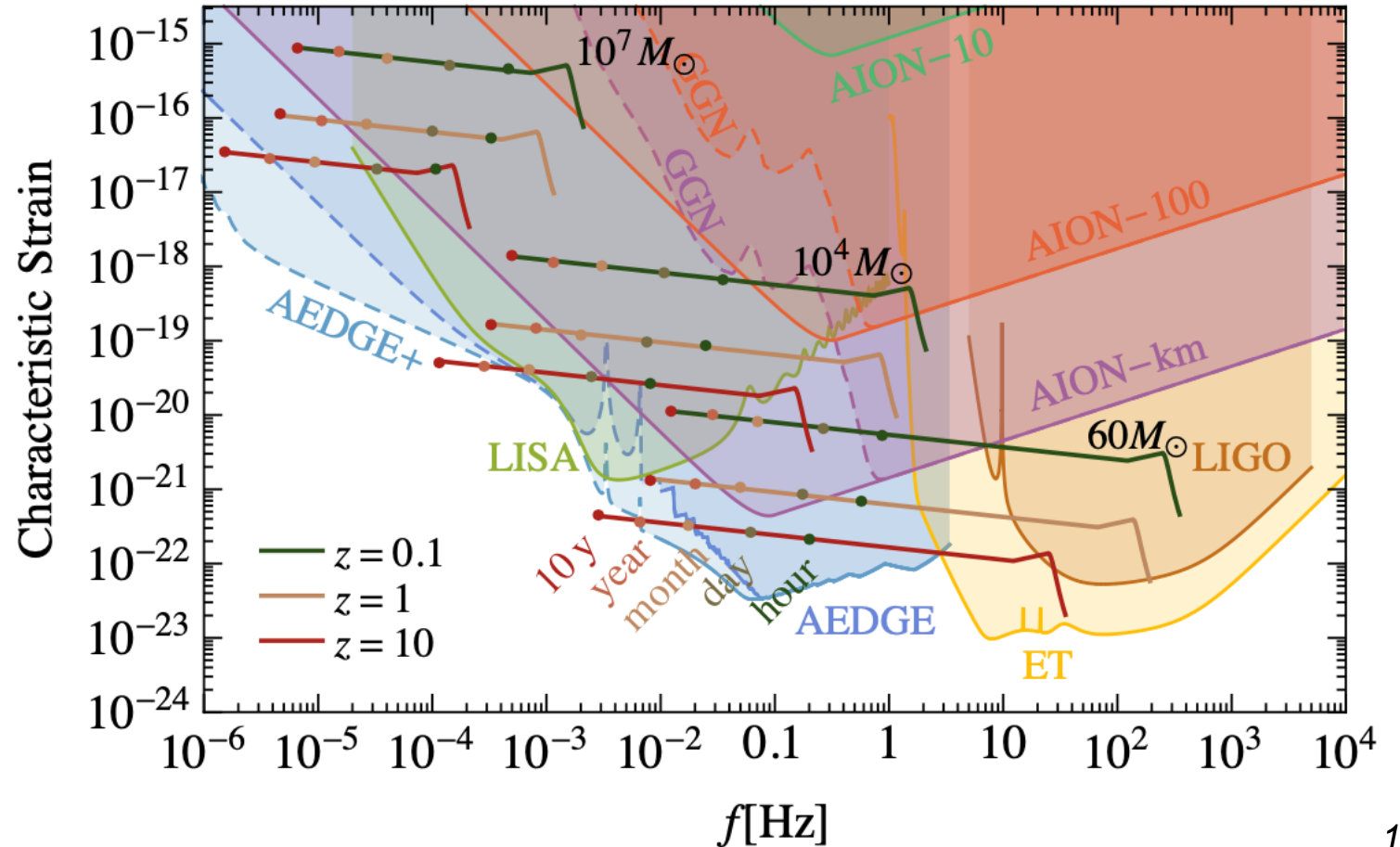
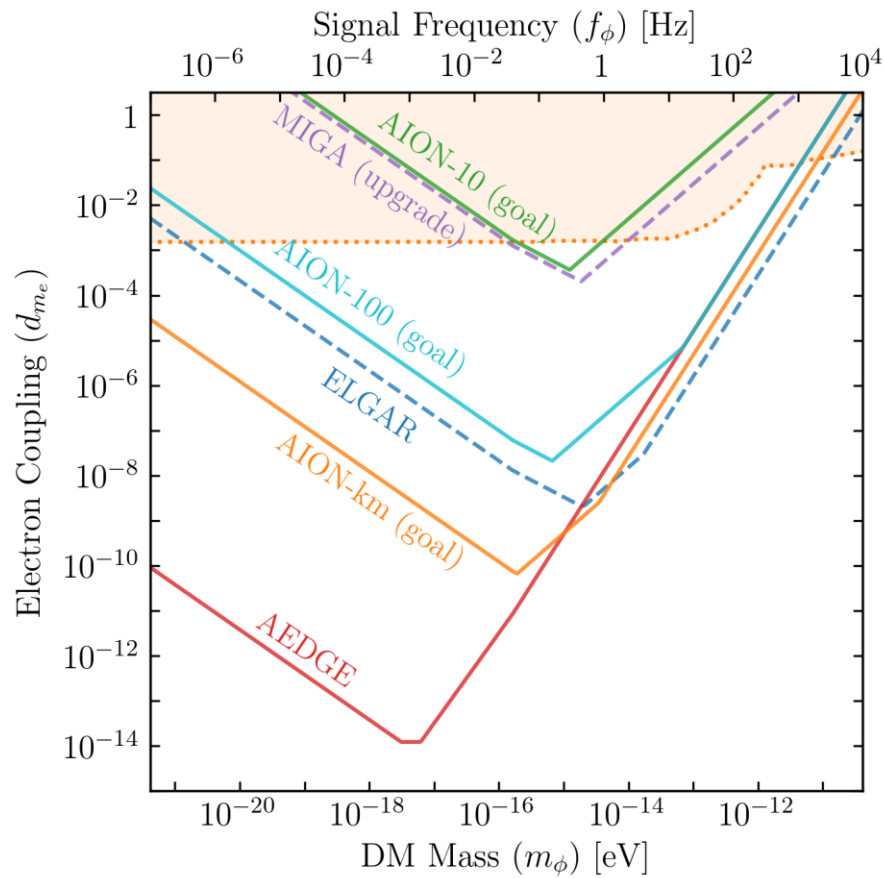

THE SCIENCE CASE

UNEXPLORED MID-FREQUENCY GRAVITATIONAL WAVES

Pathway to the GW Mid-(Frequency)

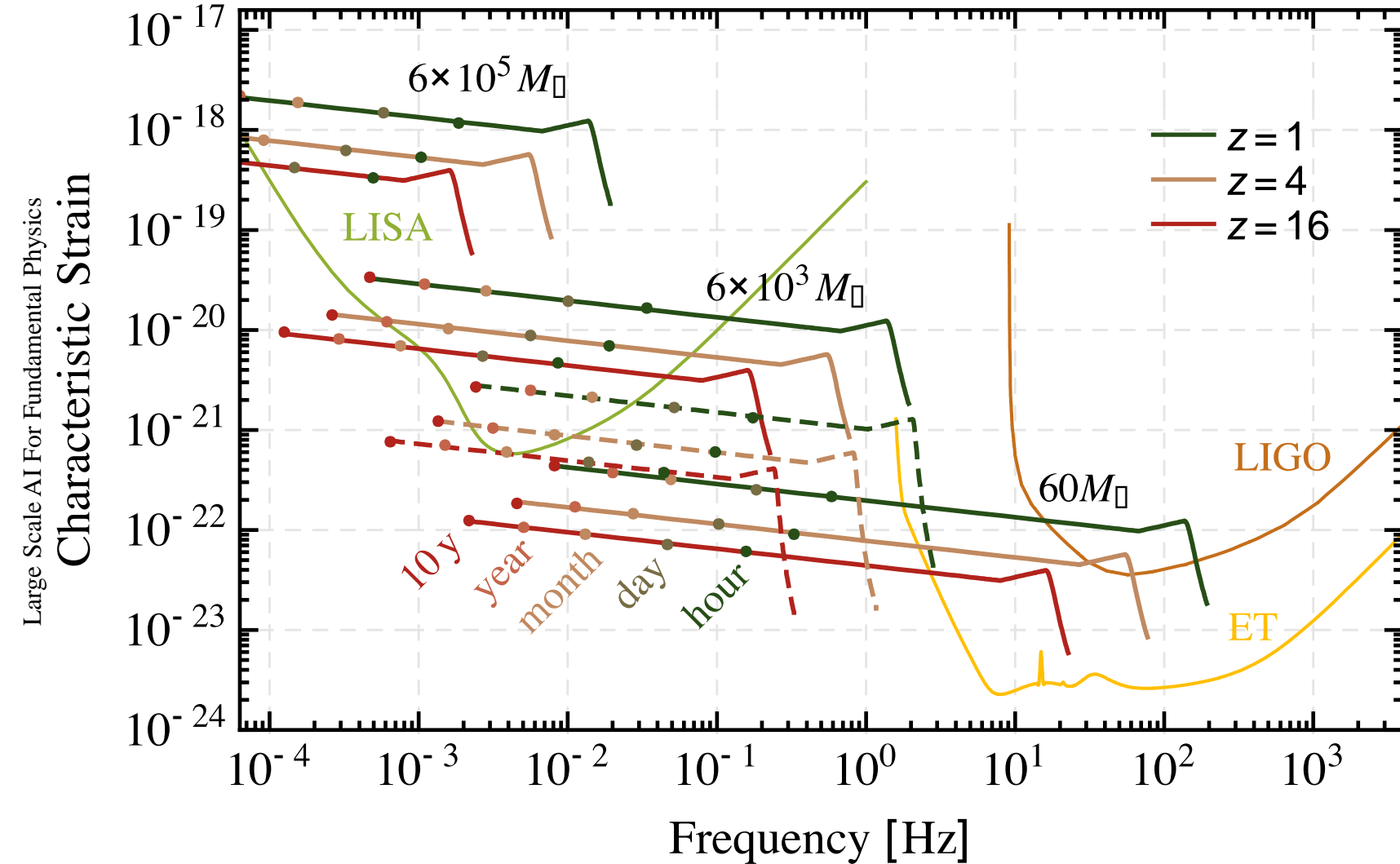

Pathway to the GW Mid-(Frequency)

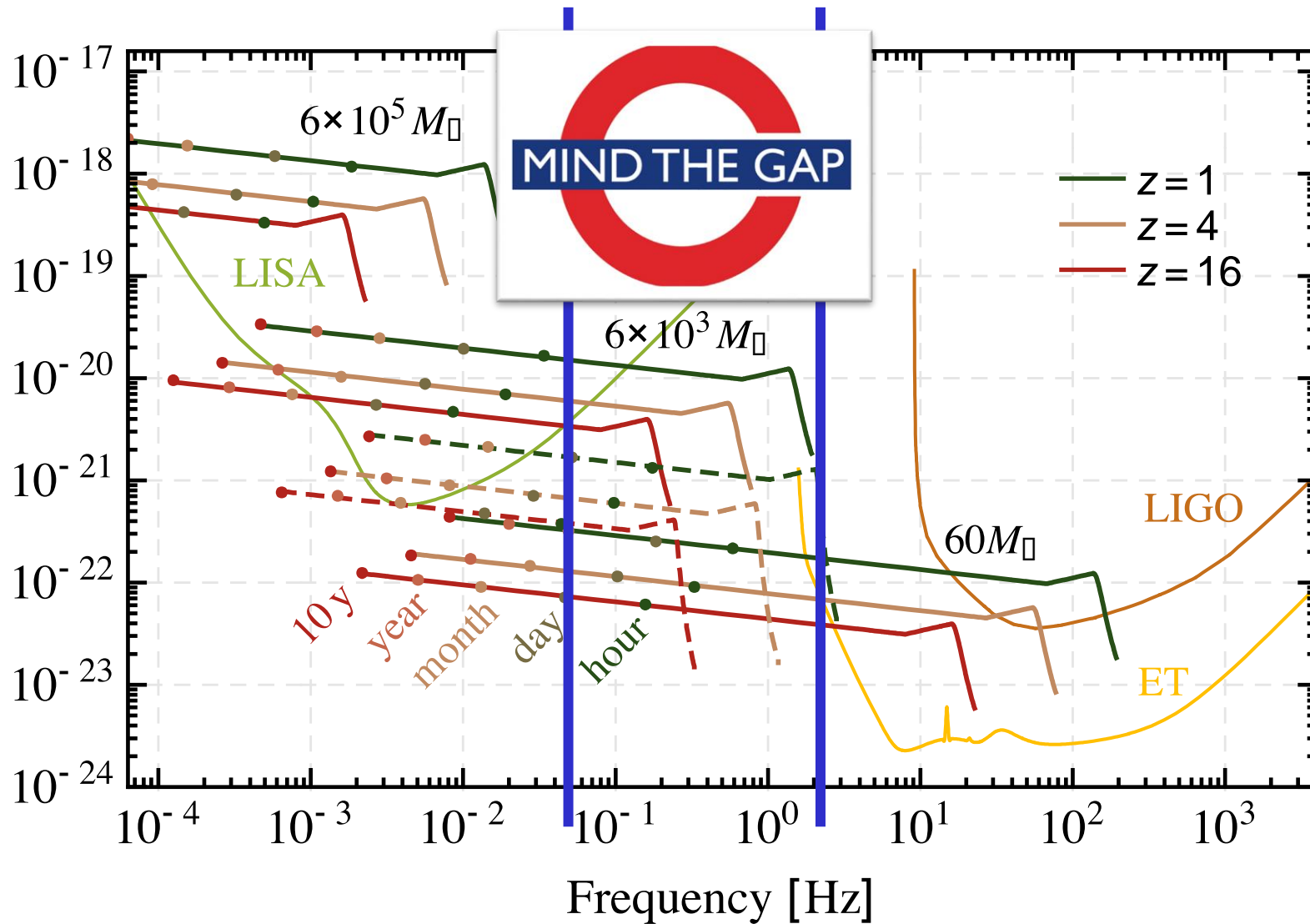

Mid-band science

- Detect sources BEFORE they reach the high frequency band [LIGO, ET]
- Optimal for sky localization: predict when and where events will occur (for multi-messenger astronomy)
- Search for Ultra-light dark matter in a similar frequency [i.e. mass] range

Mid-Band currently
NOT covered

AION: Pathway to the GW Mid-(Frequency)

Large Scale AI For Fundamental Physics

Characteristic Strain

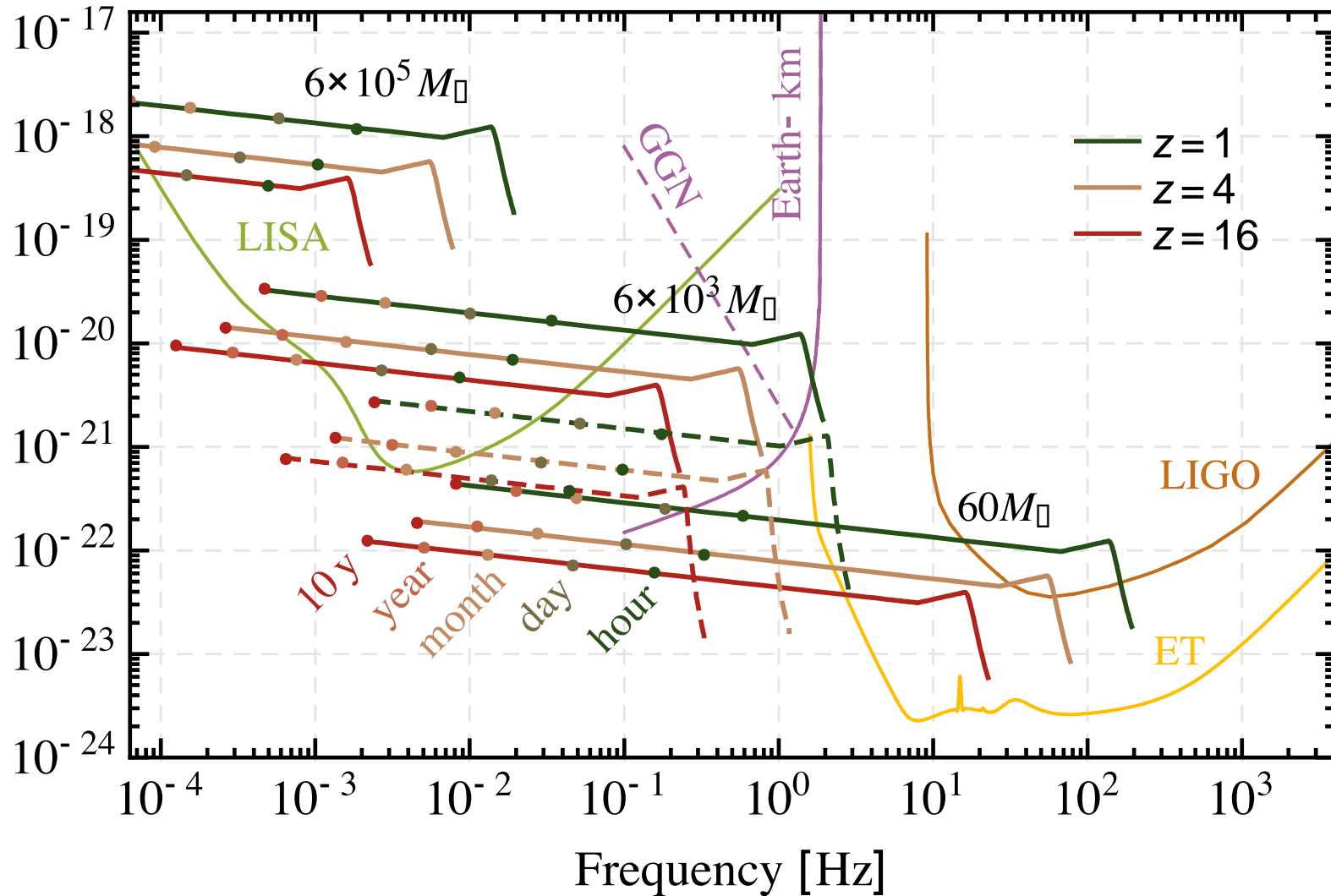

Mid-band science

- Detect sources BEFORE they reach the high frequency band [LIGO, ET]
- Optimal for sky localization: predict when and where events will occur (for multi-messenger astronomy)
- Search for Ultra-light dark matter in a similar frequency [i.e. mass] range

AION:
Terrestrial
detectors can start
filling this gap

Sky position determination

Sky localization
precision:

$$\sqrt{\Omega_s} \sim \left(\text{SNR} \cdot \frac{R}{\lambda} \right)^{-1}$$

Mid-band advantages

- Small wavelength λ
- Long source lifetime (~months) maximizes effective R

Benchmark	$\sqrt{\Omega_s}$ [deg]
GW150914	0.16
GW151226	0.20
NS-NS (140 Mpc)	0.19

Courtesy of Jason Hogan!

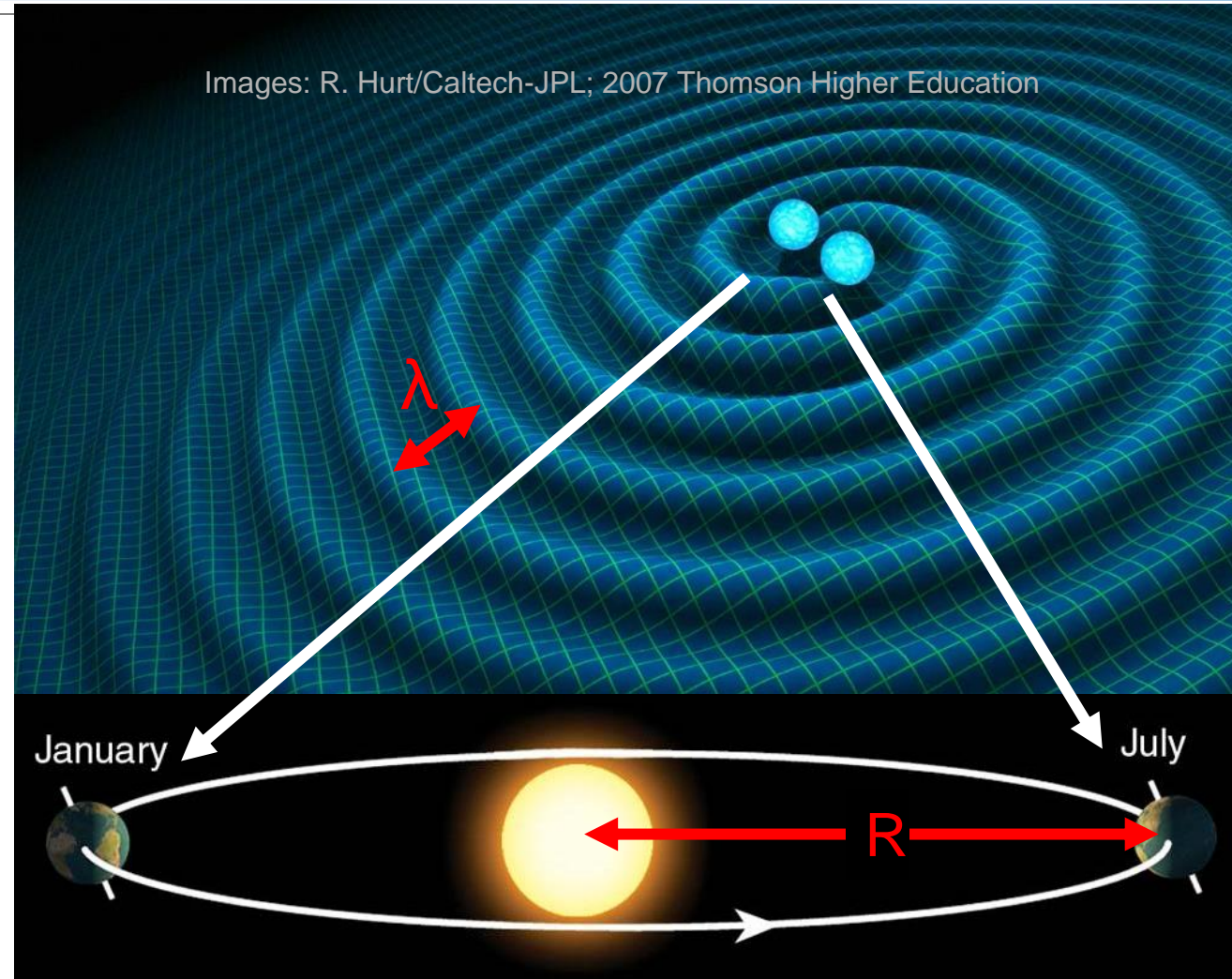

Ultimate sensitivity for terrestrial based detectors is achieved by operating 2 (or more) Detectors in synchronisation mode

Ultimate Goal: Establish International Network

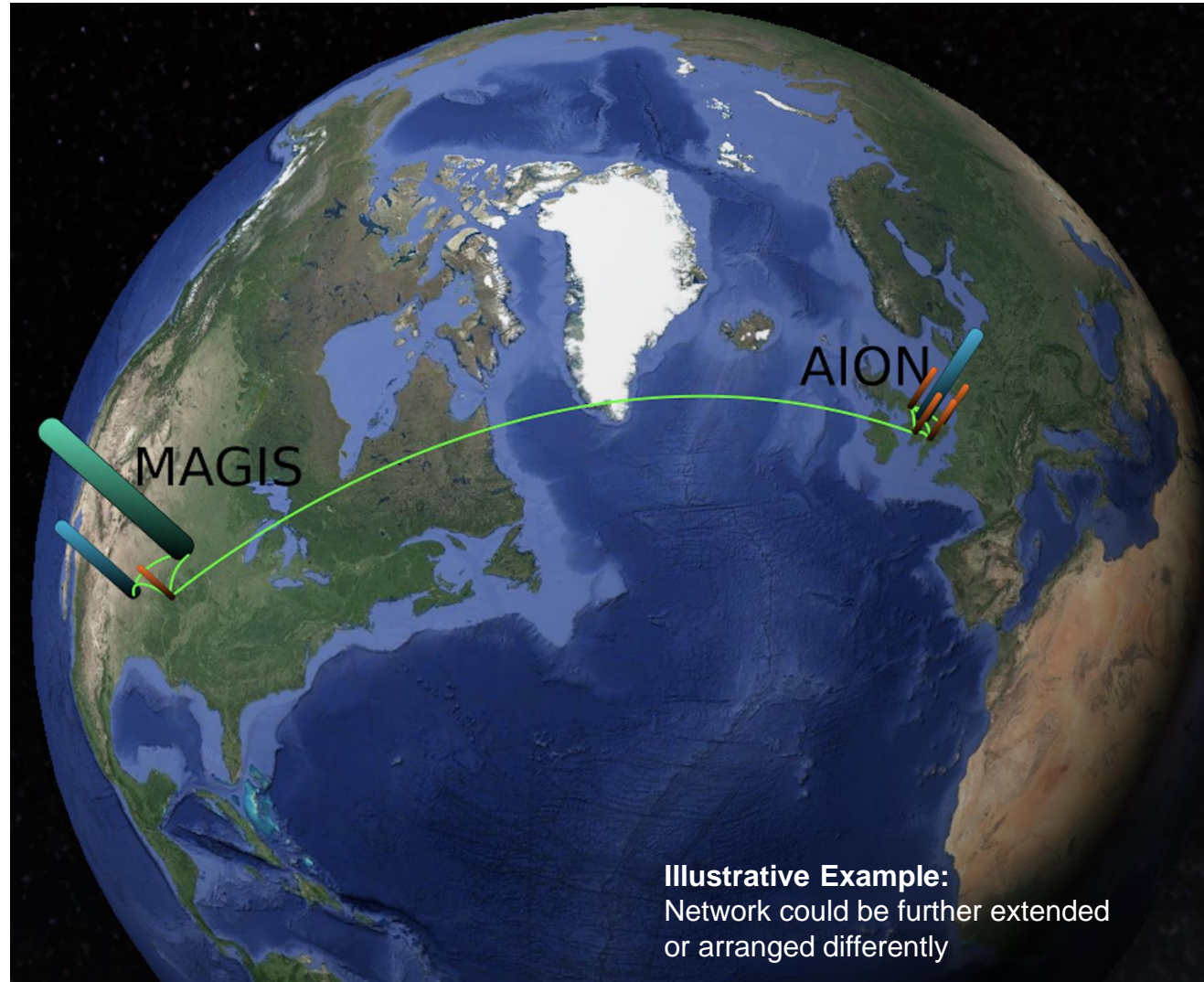

Large Scale AI For Fundamental Physics

Vision for 2045+

Probe formation of SMBHs: Synergies with other GW experiments (LIGO, LISA), test GR

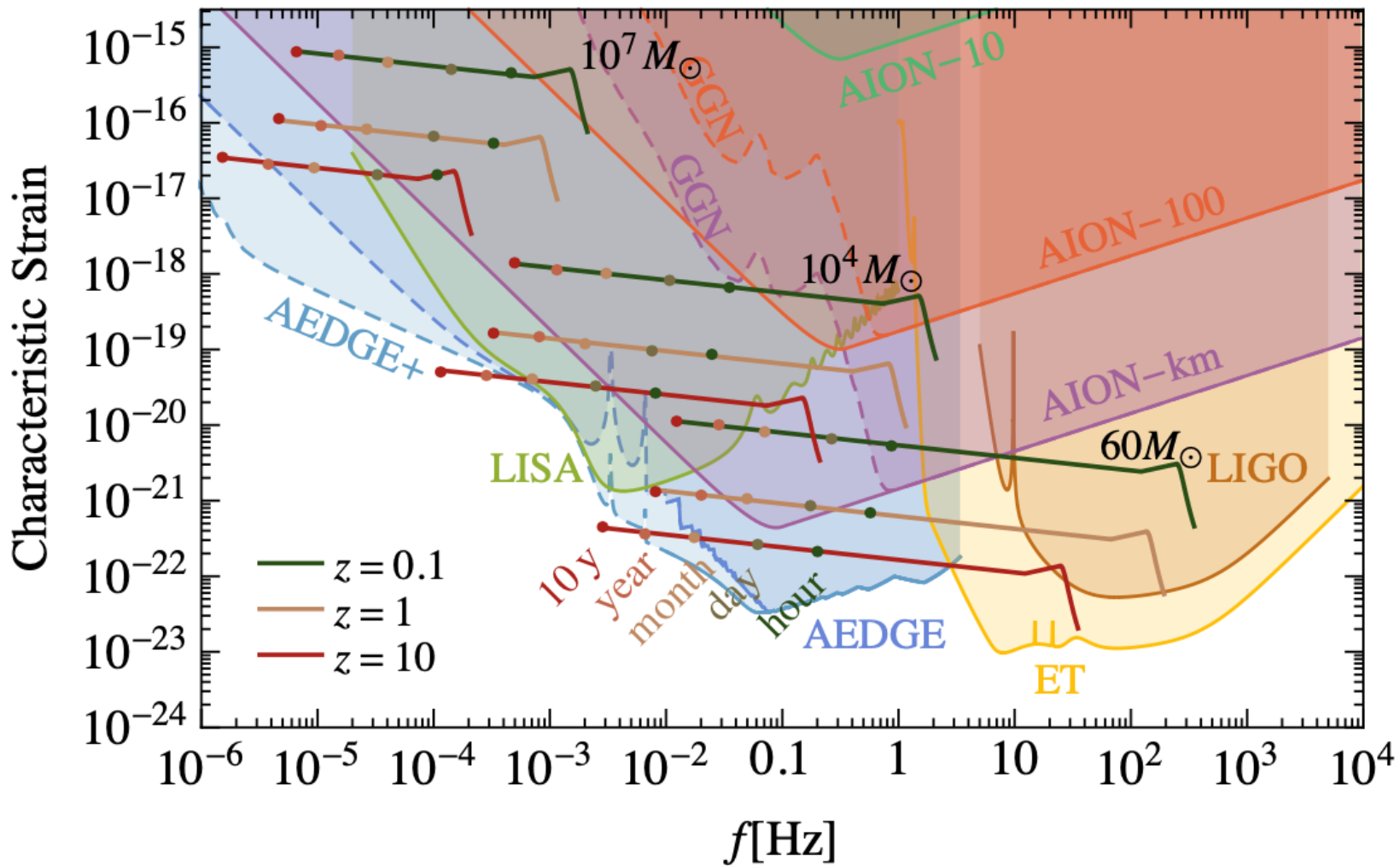

ULTRA-LIGHT DARK MATTER

Search for Ultra-Light Dark Matter

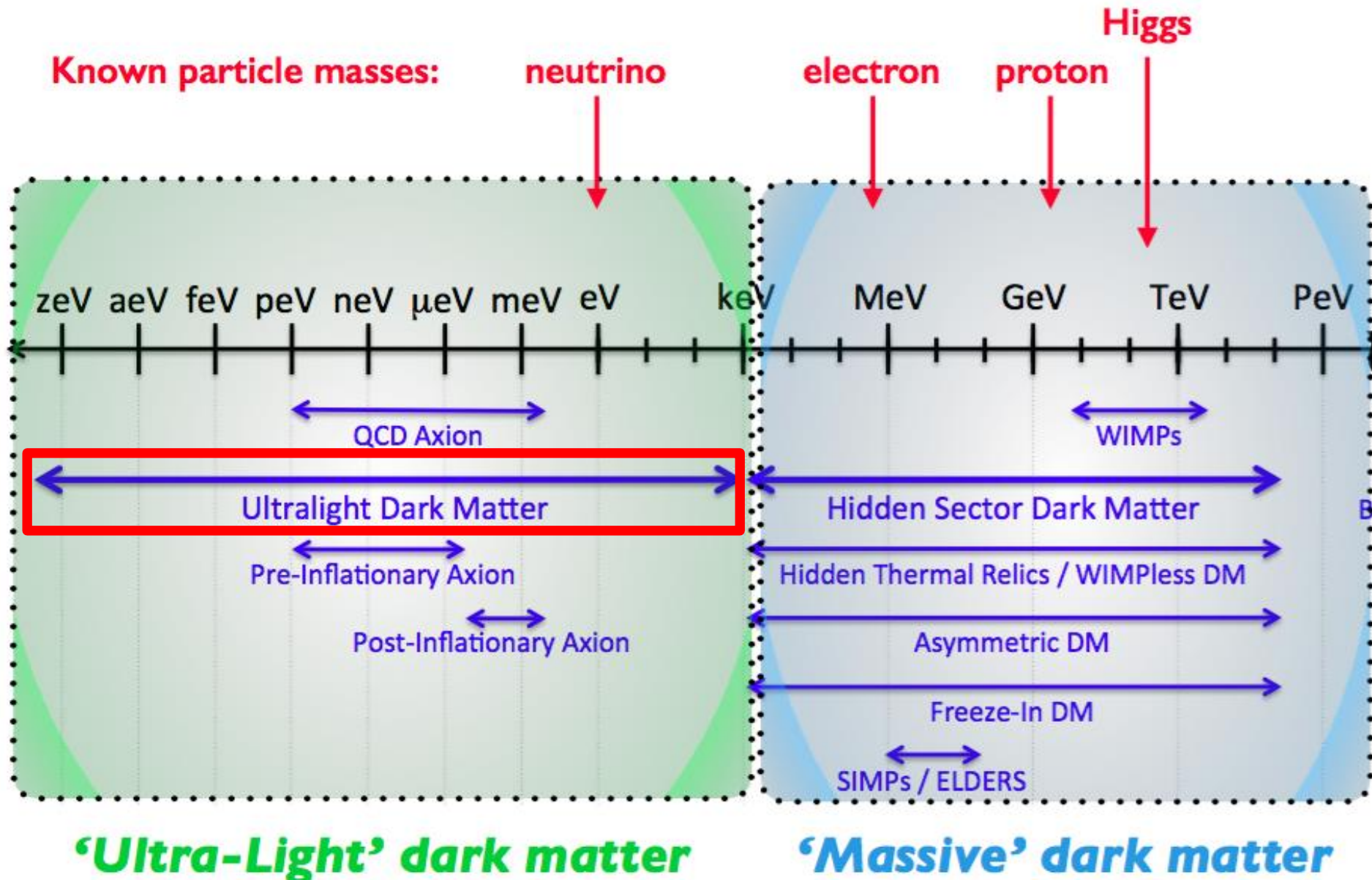

Search for Ultra-Light Dark Matter

Linear couplings to gauge fields and matter fermions

$$\mathcal{L}_{\text{int}\phi} = \kappa\phi \left[+\frac{d_e}{4e^2} F_{\mu\nu} F^{\mu\nu} - \frac{d_g\beta_3}{2g_3} F_{\mu\nu}^A F^{A\mu\nu} - \sum_{i=e,u,d} (d_{m_i} + \gamma_{m_i} d_g) m_i \bar{\psi}_i \psi_i \right]$$

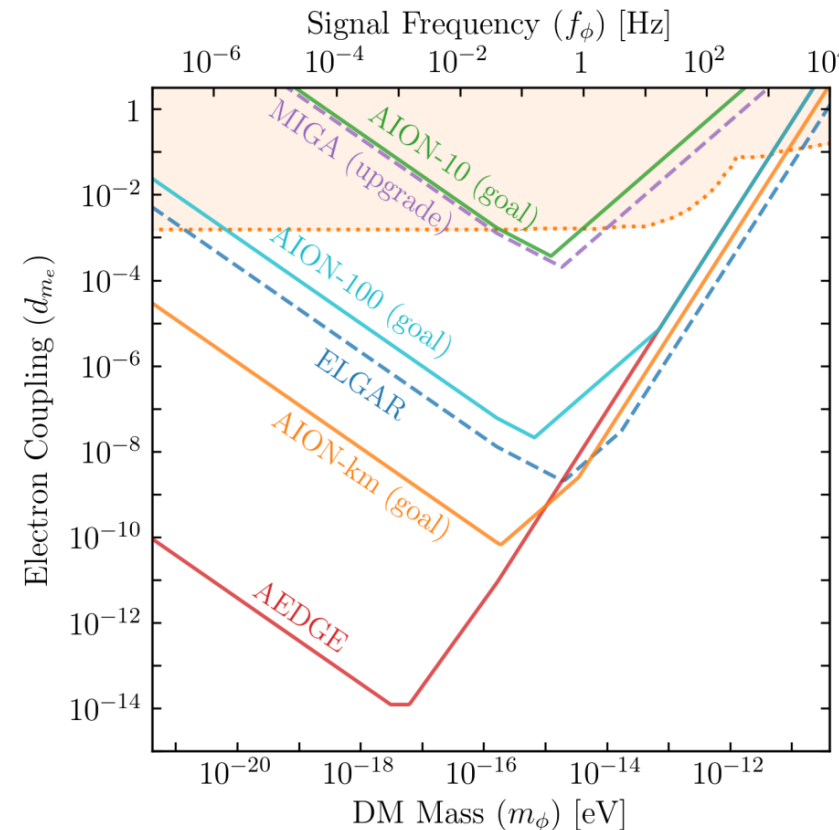
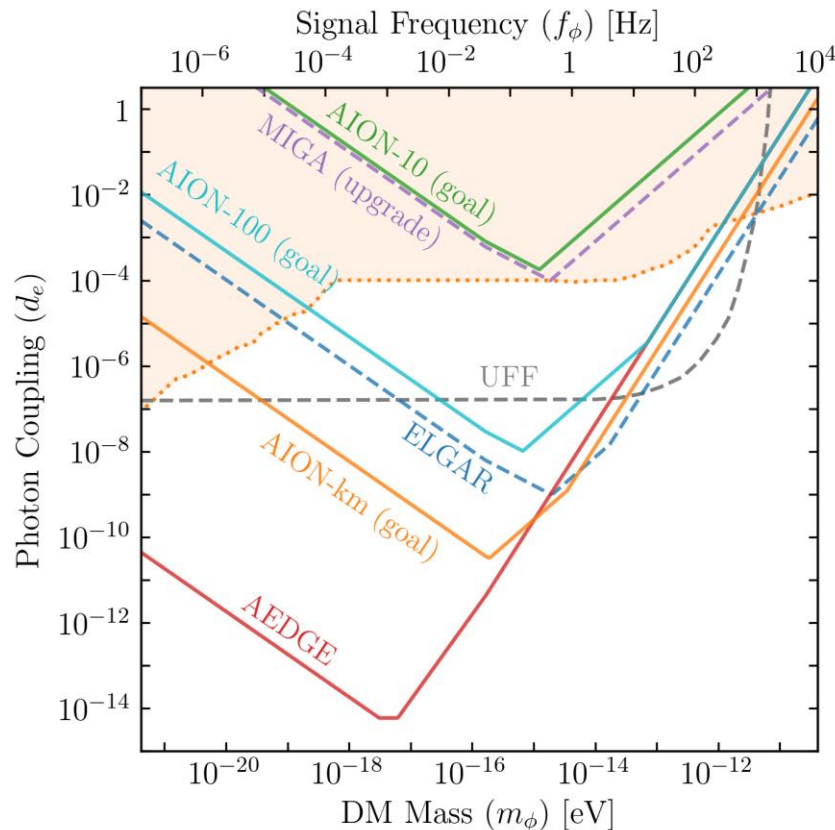

Orders of magnitude improvement over current sensitivities

Other Fundamental Physics

Ultra-high-precision atom interferometry may also be sensitive to other aspects of fundamental physics beyond dark matter and GWs, though studies of such possibilities are still at exploratory stages.

Examples may include:

- The possibility of detecting the astrophysical neutrinos
- Probes of long-range fifth forces.
- Constraining possible variations in fundamental constants.
- Probing dark energy.
- Probes of basic physical principles such as foundations of quantum mechanics and Lorentz invariance.

A very exciting new research avenue is ahead of us

BACKUP

Possible CERN Site for AION 100m

PX46 – P4 Support shaft
Lengths 143m
D = 10.10m

➤ **Ideal basic parameters for AION100**

First radiation studies are also looking promising but more work is needed to determine if PX46 could be a valid option for AION 100.

We are working with PBC Team on this feasibility study

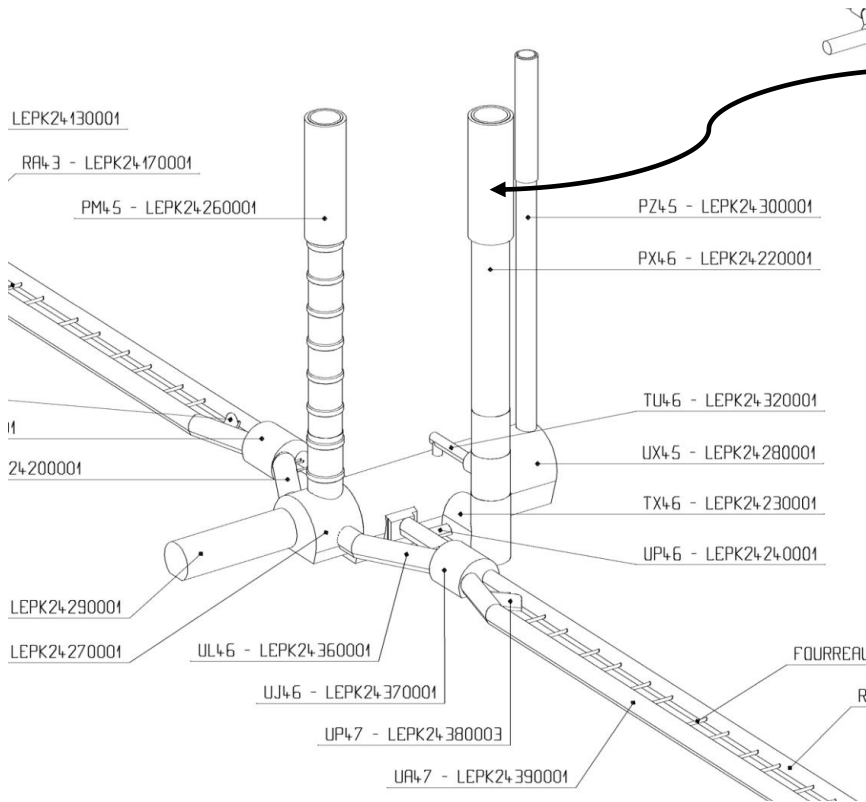
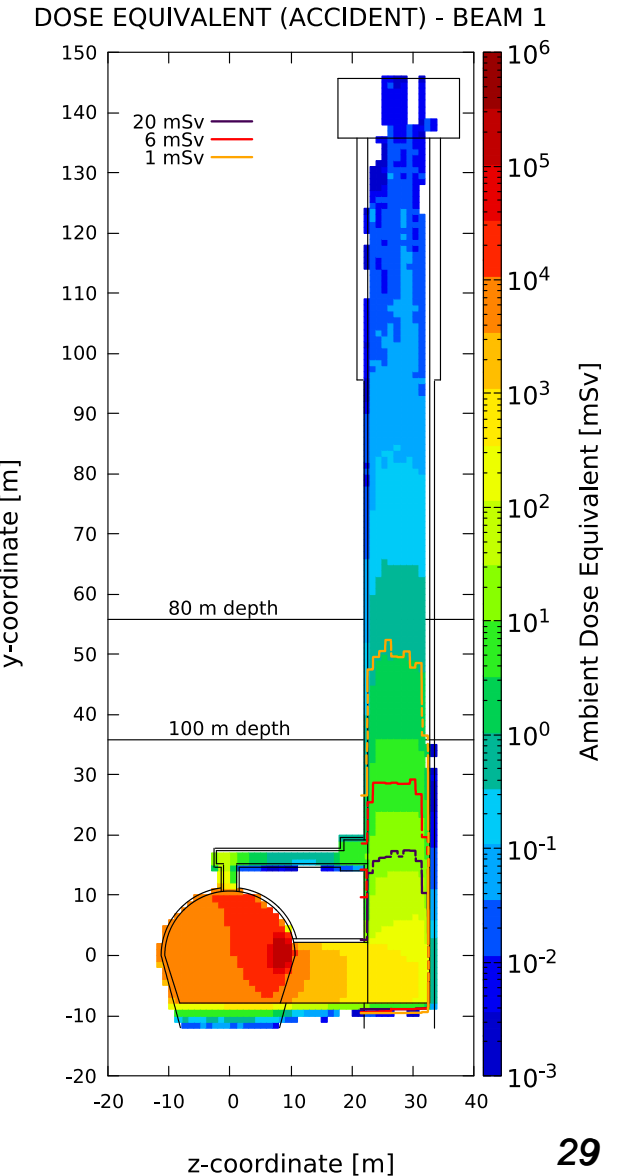
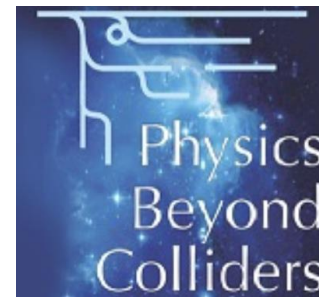

Other site options that are currently investigated are the national facility in Boulby and Daresbury (UK).

A 100 Detector at CERN – Site Investigation

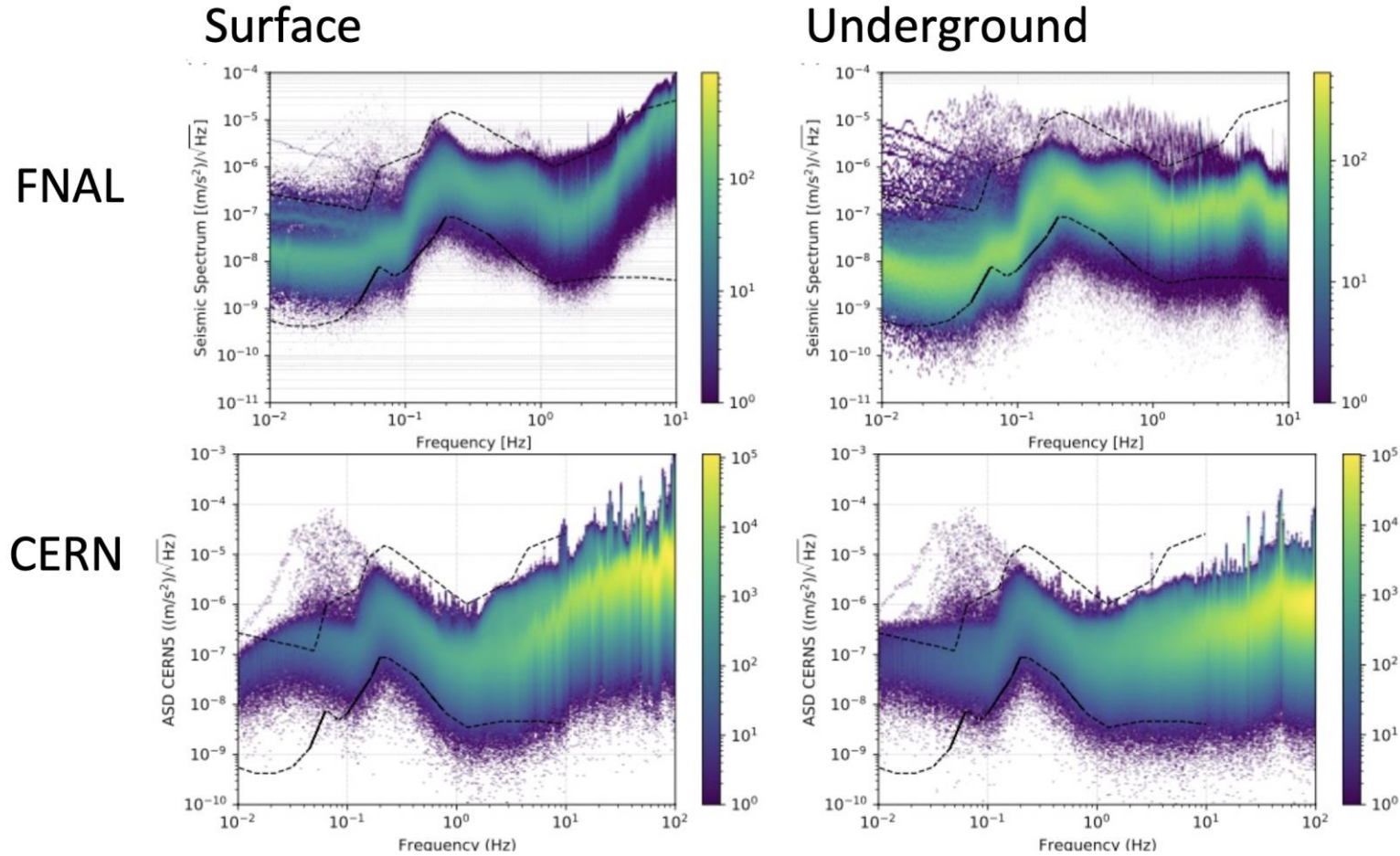

General view of LHC Point 4

Possible layout in PX46 shaft

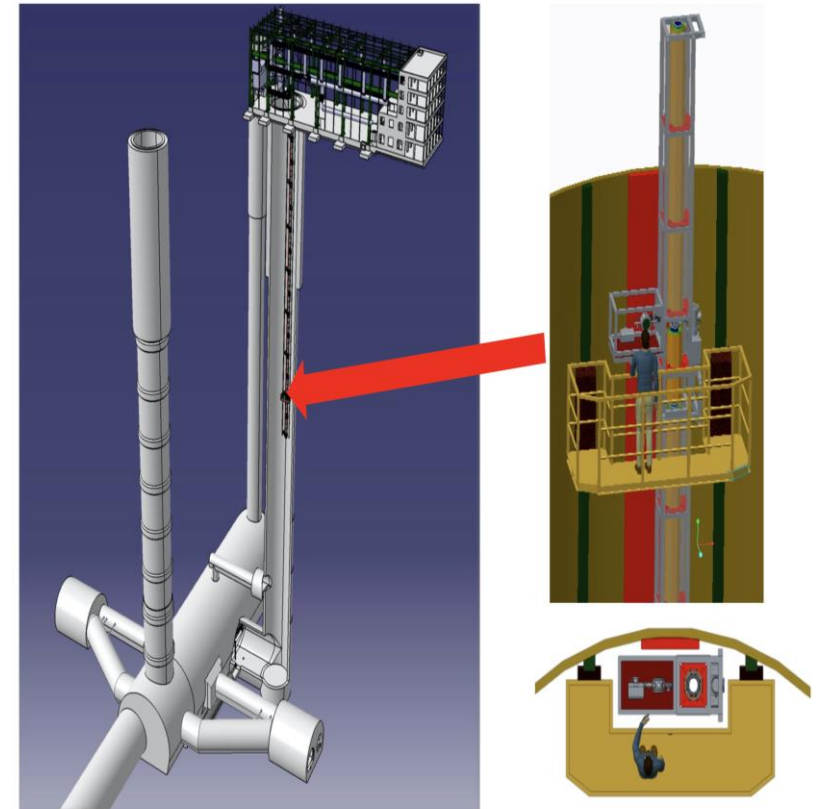

Spectrum similar to that measured at Fermilab for MAGIS
More about the site investigation in the backup

AEDGE AND STE-QUEST

Community Proposal for an ESA Road-Map for Cold Atoms in Space

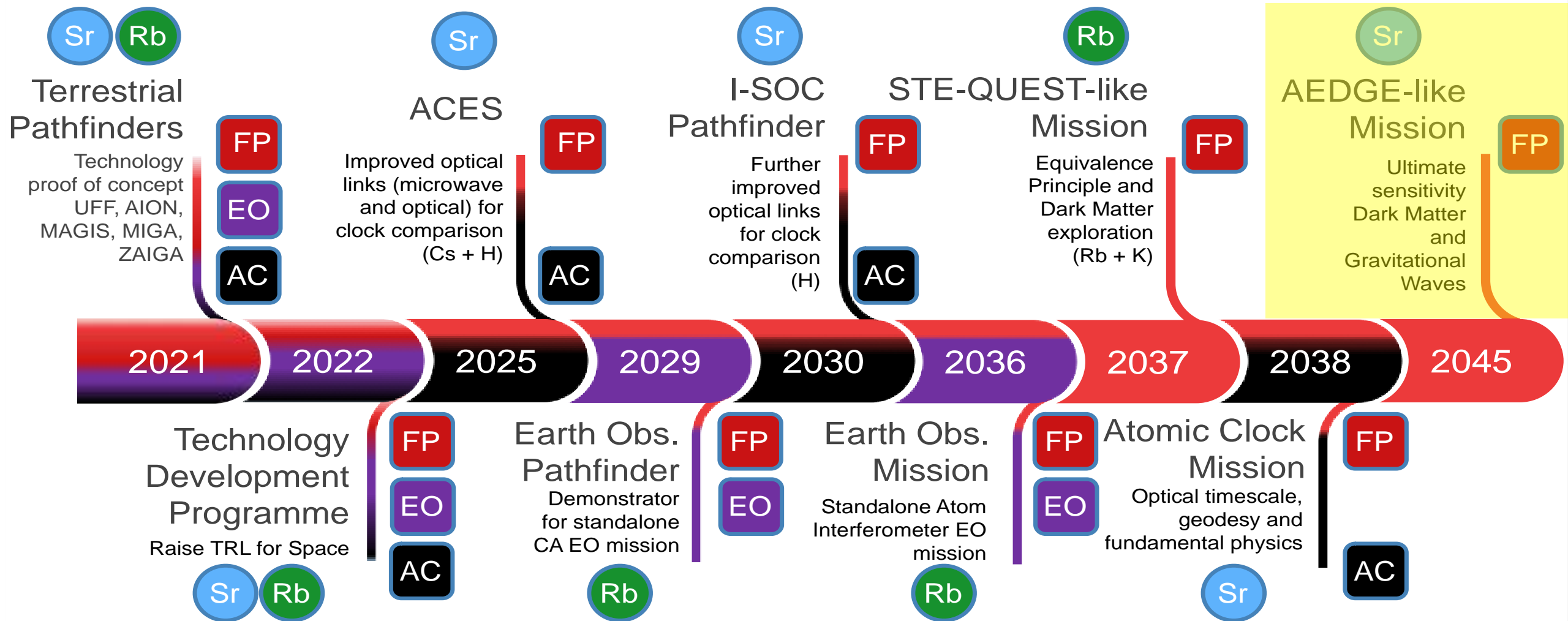

Legends:

Main Cold Atom Species

Sr Strontium **Rb** Rubidium

Areas of Relevance

EO Earth Observation **AC** Atomic Clocks **FP** Fundamental Physics

Main Milestone Area (colour coded)

2045 Example: Fundamental Physics

AEDGE: Atomic Experiment for Dark Matter and Gravity Exploration

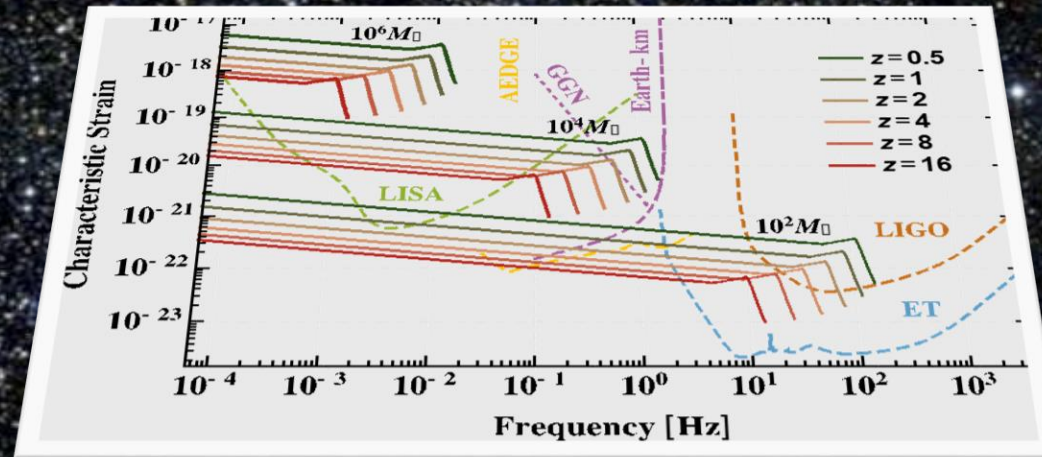
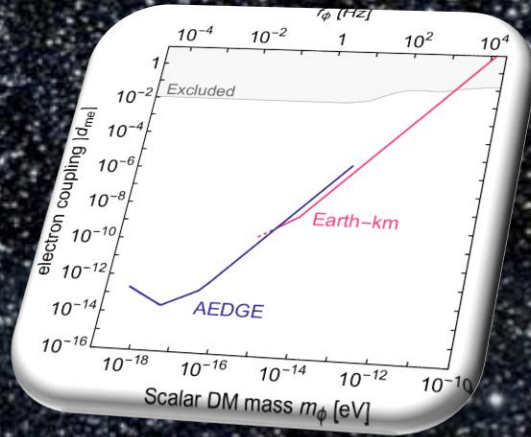

Informal Workshop
CERN, July 22/23 2019

Organizers:

Kai Bongs(CA), Philippe Bouyer(CA), Oliver Buchmueller(PP),
Albert De Roeck(PP), John Ellis(PP, Theory), Peter Graham (CA, Theory),
Jason Hogan (CA), Wolf von Klitzing(CA), Guglielmo Tino(CA), and AtomQT
PP=Particle Physics
CA=Cold Atoms

AEDGE: Atomic Experiment for Dark Matter and Gravity Exploration

**With more than 130 participants
the workshop was very well attended!**

**The full agenda can be accessed via:
<https://indico.cern.ch/event/830432/timetable/>**

**The main scope was to review the
landscape of Cold Atom
experiments on ground AND in
space to eventually establish a
roadmap for technology readiness
for space.**

**Informal Workshop
CERN, July 22/23 2019**

Organizers:

Kai Bongs(CA), Philippe Bouyer(CA), Oliver Buchmueller(PP),
Albert De Roeck(PP), John Ellis(PP, Theory), Peter Graham (CA, Theory),
Jason Hogan (CA), Wolf von Klitzing(CA), Guglielmo Tino(CA), and AtomQT
PP=Particle Physics
CA=Cold Atoms

AEDGE Mission Concept

AEDGE:

Atomic Experiment for Dark Matter and Gravity Exploration in Space

Yousef Abou El-Neaj,¹ Cristiano Alpigiani,² Sana Amairi-Pyka,³ Henrique Araújo,⁴ Antun Balaž,⁵ Angelo Bassi,⁶ Lars Bathe-Peters,⁷ Baptiste Battelier,⁸ Aleksandar Belić,⁵ Elliot Bentine,⁹ José Bernabeu,¹⁰ Andrea Bertoldi,^{8,*} Robert Bingham,¹¹ Diego Blas,¹² Vasiliki Bolpasi,¹³ Kai Bongs,^{14,*} Sougato Bose,¹⁵ Philippe Bouyer,^{8,*} Themis Bowcock,¹⁶ William Bowden,¹⁷ Oliver Buchmueller,^{4,*} Clare Burrage,¹⁸ Xavier Calmet,¹⁹ Benjamin Canuel,^{8,*} Laurentiu-Ioan Caramete,^{20,*} Andrew Carroll,¹⁶ Giancarlo Cella,^{21,22} Vassilis Charmandaris,²³ Swapan Chattopadhyay,^{24,25} Xuzong Chen,²⁶ Maria Luisa Chiofalo,^{21,22} Jonathon Coleman,^{16,*} Joseph Cotter,⁴ Yanou Cui,²⁷ Andrei Derevianko,²⁸ Albert De Roeck,^{29,30,*} Goran Djordjevic,³¹ Peter Dornan,⁴ Michael Doser,³⁰ Ioannis Drougkakis,¹³ Jacob Dunningham,¹⁹ Ioana Dutan,²⁰ Sajan Easo,¹¹ Gedminas Elertas,¹⁶ John Ellis,^{12,32,33,*} Mai El Sawy,³⁴ Farida Fassi,³⁵ Daniel Felea,²⁰ Chen-Hao Feng,⁸ Robert Flack,¹⁵ Chris Foot,⁹ Ivette Fuentes,¹⁸ Naceur Gaaloul,³⁶ Alexandre Gauguet,³⁷ Remi Geiger,³⁸ Valerie Gibson,³⁹ Gian Giudice,³³ Jon Goldwin,¹⁴ Oleg Grachov,⁴⁰ Peter W. Graham,^{41,*} Dario Grasso,^{21,22} Maurits van der Grinten,¹¹ Mustafa Gündogan,³ Martin G. Haehnel,^{42,*} Tiffany Harte,³⁹ Aurélien Hees,^{38,*} Richard Hobson,¹⁷ Bodil Holst,⁴³ Jason Hogan,^{41,*} Mark Kasevich,⁴¹ Bradley J. Kavanagh,⁴⁴ Wolf von Klitzing,^{13,*} Tim Kovachy,⁴⁵ Benjamin Kriker,⁴⁶ Markus Krutzik,^{3,*} Marek Lewicki,^{12,47,*} Yu-Hung Lien,¹⁵ Miaoyuan Liu,²⁶ Giuseppe Gaetano Luciano,⁴⁸ Alain Magnon,⁴⁹ Mohammed Mahmoud,⁵⁰ Sarah Malik,⁴ Christopher McCabe,^{12,*} Jeremiah Mitchell,²⁴ Julia Pahl,³ Debapriya Pal,¹³ Saurabh Pandey,¹³ Dimitris Papazoglou,⁵¹ Mauro Paternostro,⁵² Bjoern Penning,⁵³ Achim Peters,^{3,*} Marco Prevedelli,⁵⁴ Vishnupriya Puthiya-Veetil,⁵⁵ John Quenby,⁴ Ernst Rasel,^{36,*} Sean Ravenhall,⁹ Haifa Rejeb Sfar,²⁹ Jack Ringwood,¹⁶ Albert Roura,^{56,*} Dylan Sabulsky,^{8,*} Muhammed Sameed,⁵⁷ Ben Sauer,⁴ Stefan Alaric Schäffer,⁵⁸ Stephan Schiller,^{59,*} Vladimir Schkolnik,³ Dennis Schlippert,³⁶ Christian Schubert,^{3,*} Armin Shayeghi,⁶⁰ Ian Shipsey,⁹ Carla Signorini,^{21,22} Marcelle Soares-Santos,⁵³ Fiodor Sorrentino,^{61,*} Yajpal Singh,^{14,*} Timothy Sumner,⁴ Konstantinos Tassis,¹³ Silvia Tentindo,⁶² Guglielmo Maria Tino,^{63,64,*} Jonathan N. Tinsley,⁶³ James Unwin,⁶⁵ Tristan Valenzuela,¹¹ Georgios Vasilakis,¹³ Ville Vaskonen,^{12,32,*} Christian Vogt,⁶⁶ Alex Webber-Date,¹⁶ André Wenzlawski,⁶⁷ Patrick Windpassinger,⁶⁷ Marian Woltmann,⁶⁶ Michael Holynski,¹⁴ Efe Yazgan,⁶⁸ Ming-Sheng Zhan,^{69,*} Xinhao Zou,⁸ Jure Zupan⁷⁰

132 Authors, from **70** institutions,
based in **23** different countries!

The authors represent several science communities ranging from Cold Atoms, & Gravitational Waves, over Cosmology and Astrophysics to fundamental Particle Physics.

<https://arxiv.org/abs/1908.00802>

The paper is now published in **EPJ Quantum Technology**

Potential Mission Design

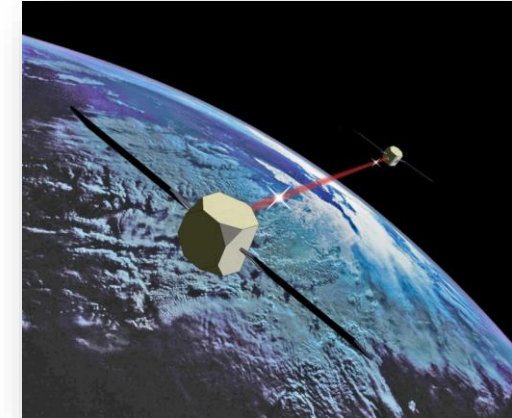
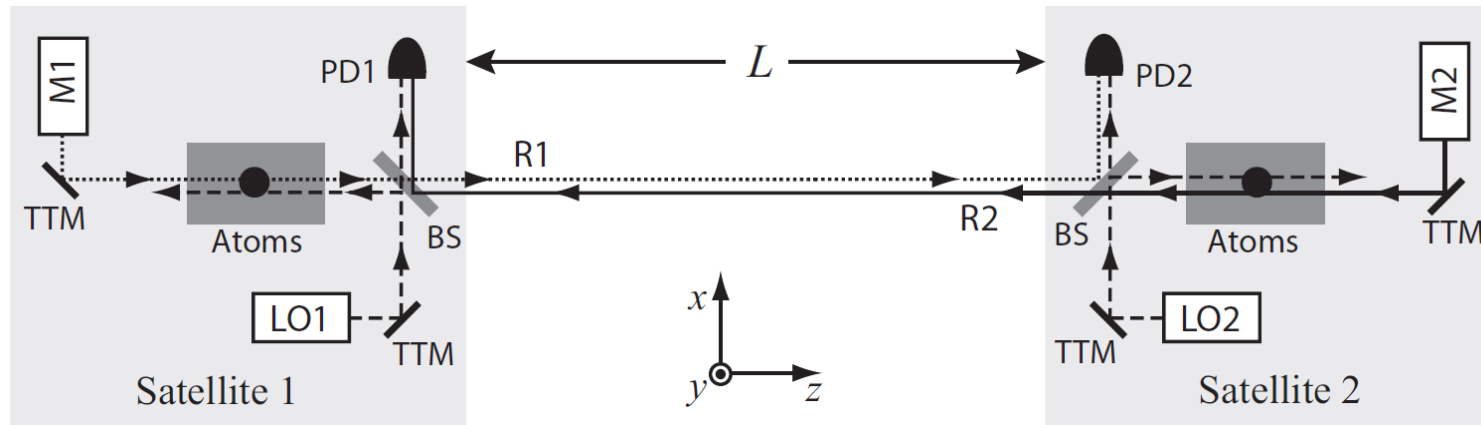

Using two cold-atom interferometers that perform a relative measurement of differential phase shift, a potential mission profile would be using a pair of satellites separated by a very long baseline L .

Assumed basic parameters:

- Pair of satellites in medium earth orbit (MEO)
- Satellite separation $L = 4.4 \times 10^7$ m

Note: as Laser noise is common-mode suppressed only two satellites are required

Community Proposal for an ESA Road-Map for Cold Atoms in Space

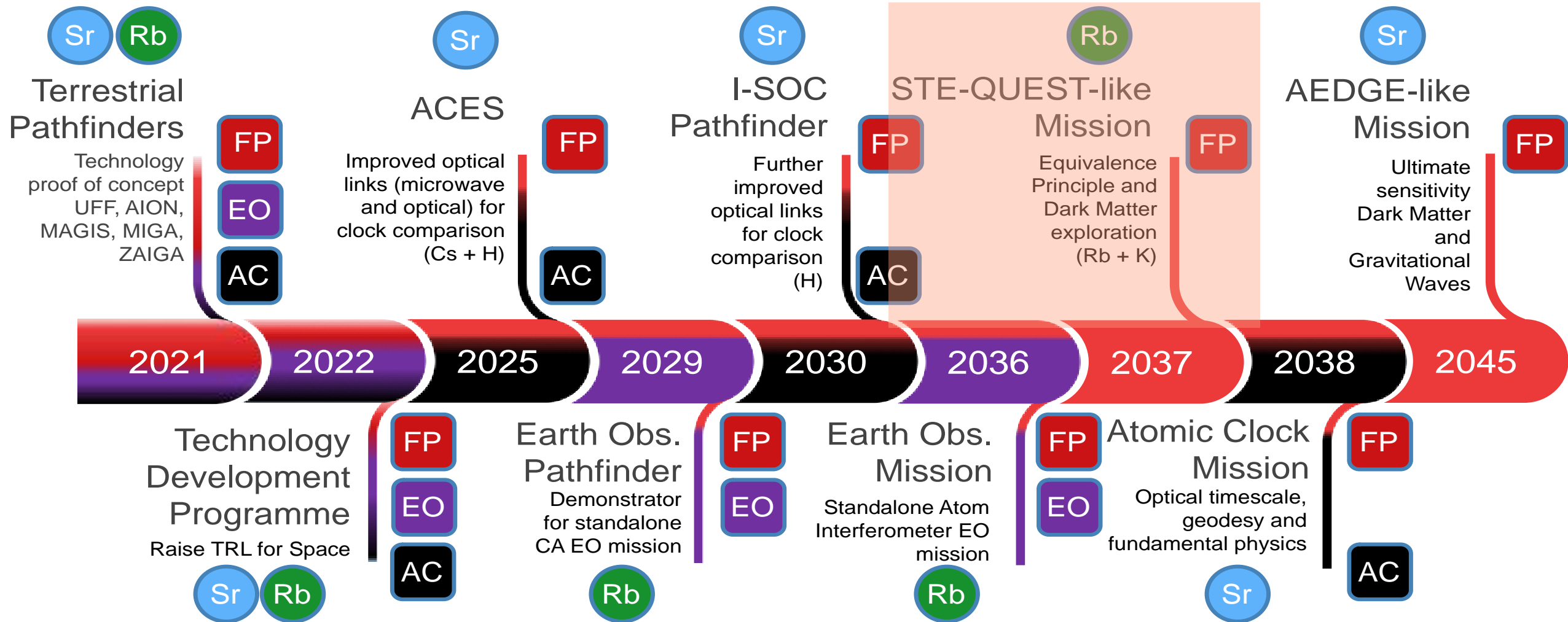

Legends:

Main Cold Atom Species

Sr Strontium **Rb** Rubidium

Areas of Relevance

EO Earth Observation **AC** Atomic Clocks **FP** Fundamental Physics

Main Milestone Area (colour coded)

2045 Example: Fundamental Physics

STE-QUEST (M-Class Mission Proposal)

STE-QUEST

Space Time Explorer and QUantum Equivalence principle Space Test

A M-class mission proposal in response to the 2022 call in ESA's science program

Core Team:

- Angelo Bassi, Department of Physics, University of Trieste, and INFN - Trieste Section, *Italy*
- Kai Bongs, Midlands Ultracold Atom Research Centre, School of Physics and Astronomy University of Birmingham, *United Kingdom*
- Philippe Bouyer, LP2N, Université Bordeaux, IOGS, CNRS, Talence, *France*
- Claus Braxmaier, Institute of Microelectronics, Ulm University and Institute of Quantum Technologies, German Aerospace Center (DLR), *Germany*
- Oliver Buchmueller, High Energy Physics Group, Blackett Laboratory, Imperial College London, London, *United Kingdom*
- Maria Luisa (Marily) Chiofalo, Physics Department "Enrico Fermi" University of Pisa, and INFN-Pisa *Italy*
- John Ellis, Physics Department, King's College London, *United Kingdom*
- Naceur Gaaloul, Institute of Quantum Optics, Leibniz University of Hanover, *Germany*
- Aurélien Hees, SYRTE, Observatoire de Paris-PSL, CNRS, Sorbonne Université, LNE, Paris, *France*
- Philippe Jetzer, Department of Physics, University of Zurich, *Switzerland*
- Steve Lecomte, Centre Suisse d'Electronique et de Microtechnique (CSEM), Neuchâtel, *Switzerland*
- Gilles Métris, Université Côte d'Azur, Observatoire de la Côte d'Azur, CNRS, IRD, Géoazur, *France*
- Ernst M. Rasel, Institute of Quantum Optics, Leibniz University of Hanover, *Germany*
- Thilo Schuldt, German Aerospace Center (DLR), Institute of Quantum Technologies, Ulm *Germany*
- Carlos F. Sopuerta, Institute of Space Sciences (ICE, CSIC), Institute of Space Studies of Catalonia (IEEC), *Spain*
- Guglielmo M. Tino, Dipartimento di Fisica e Astronomia and LENS, Università di Firenze, INFN, CNR *Italy*
- Wolf von Klitzing, Institute of Electronic Structure and Laser, Foundation for Research and Technology Hellas, *Greece*
- Lisa Wörner, German Aerospace Center (DLR), Institute of Quantum Technologies, Ulm *Germany*
- Nan Yu, Jet Propulsion Laboratory, California Institute of Technology, Pasadena, CA 91109, *USA*
- Martin Zelan, Measurement Science and Technology, RISE Research Institutes of Sweden, Borås, *Sweden*

Strong
International Team

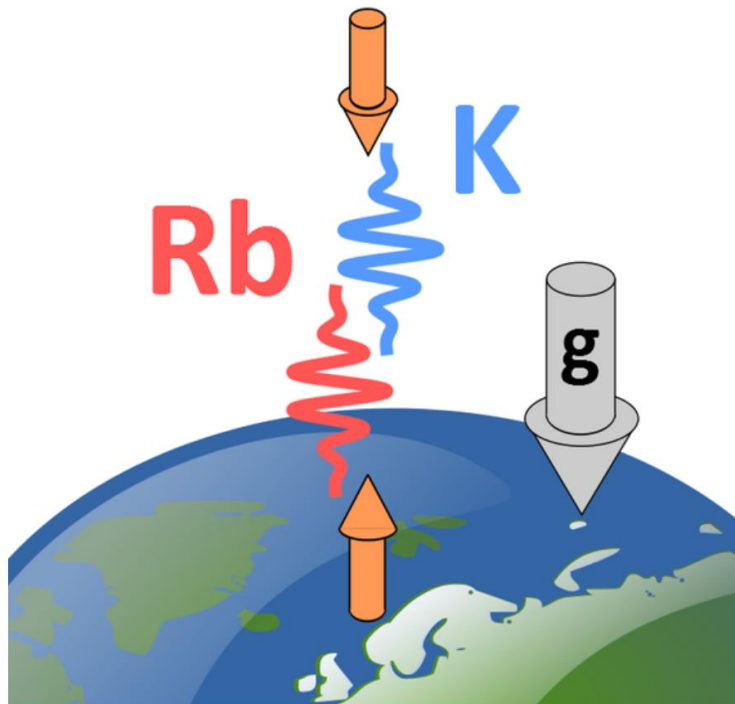

Large Scale AI For Fundamental Physics

STE-QUEST: An M-class Cold Atom mission to probe gravity, dark matter and quantum mechanics

Science Goals: Equivalent Principal at 1E-17, Ultra-Light Dark Matter, Test of Quantum Mechanics

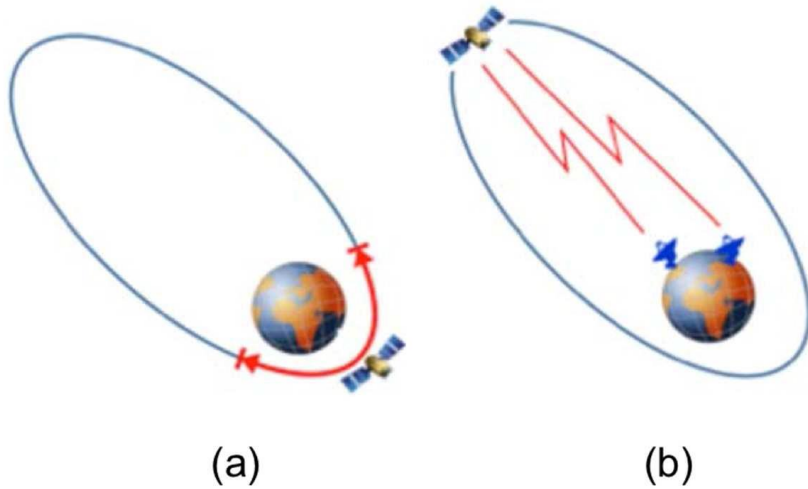

- Based on STE-QUEST proposals (M3, M4).
- Double atom interferometer with Rb and K “test masses” in non-classical states (quantum superpositions).
- Optimized for UFF test. Assume 700 km circular orbit.
- Apply recent results on controlling gravity gradient shifts by offsetting laser frequencies, thus relaxing atom positioning requirements by factor >100.
- **Reaches 1E-17 target after 18 months of operation.**

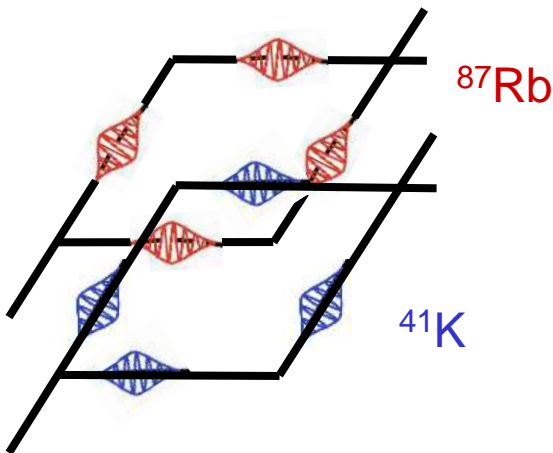

Class	Elements	η	Year [ref]	Comments
Classical	Be - Ti	2×10^{-13}	2008	Torsion balance
	Pt - Ti	1×10^{-14}	2017	MICROSCOPE first results
	Pt - Ti	(10^{-15})	2022+	MICROSCOPE full data
Hybrid	^{133}Cs - CC	7×10^{-9}	2001	Atom Interferometry
	^{87}Rb - CC	7×10^{-9}	2010	and macroscopic corner cube (CC)
Quantum	^{39}K - ^{87}Rb	3×10^{-7}	2020	different elements
	^{87}Sr - ^{88}Sr	2×10^{-7}	2014	same element, fermion vs. boson
	^{85}Rb - ^{87}Rb	3×10^{-8}	2015	same element, different isotopes
	^{85}Rb - ^{87}Rb	3.8×10^{-12}	2020	10 m tower
	^{41}K - ^{87}Rb	(10^{-17})	2037	STE-QUEST
Antimatter	$\bar{\text{H}}$ - H	(10^{-2})	2023+	under construction at CERN

STE-QUEST: An M-class Cold Atom mission to probe gravity, dark matter and quantum mechanics

Science Goals: I

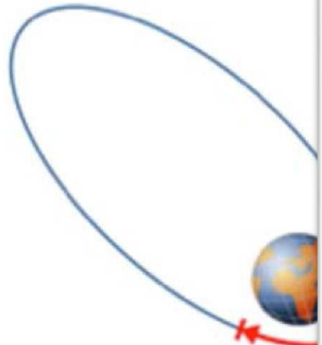

(a)

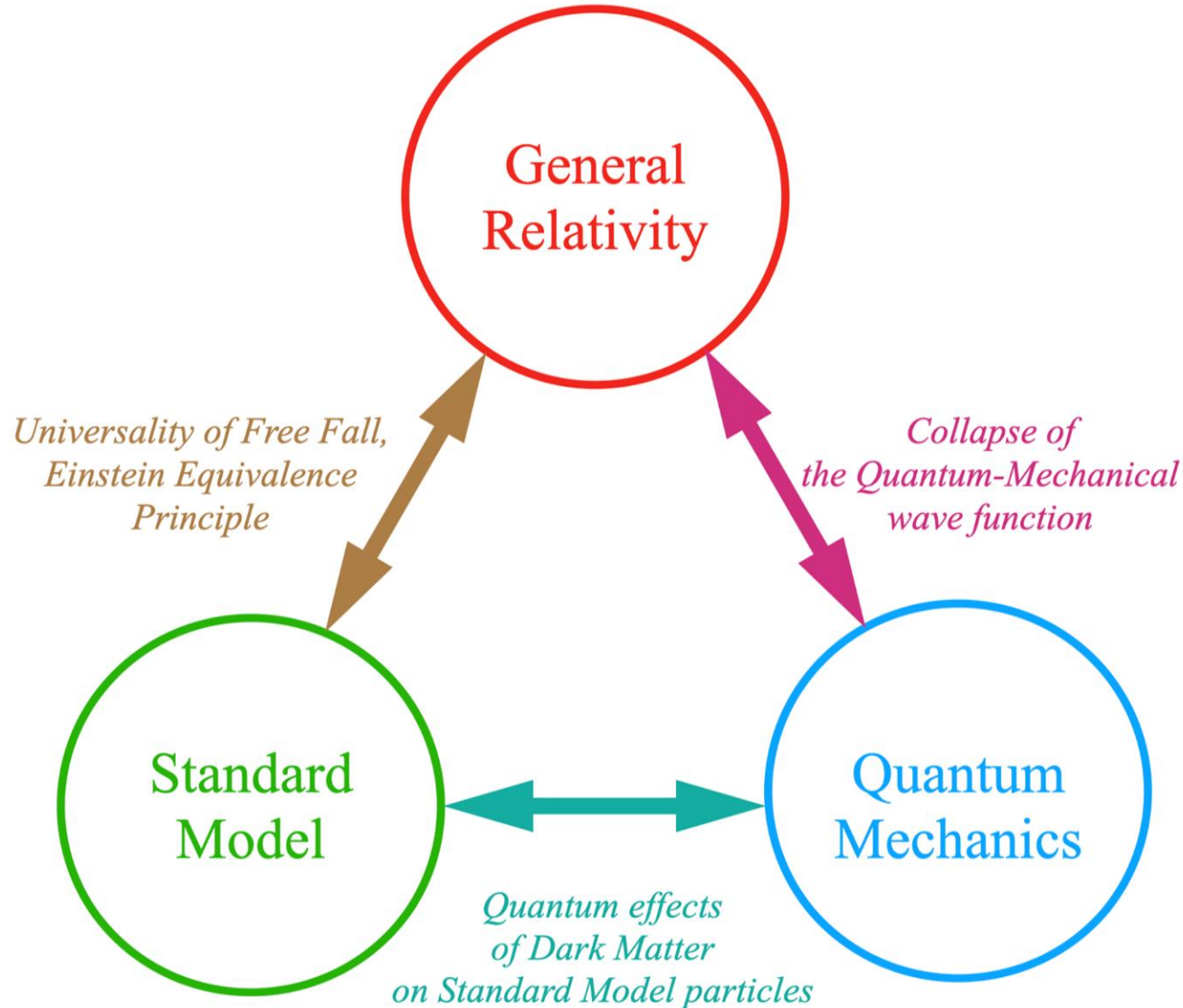
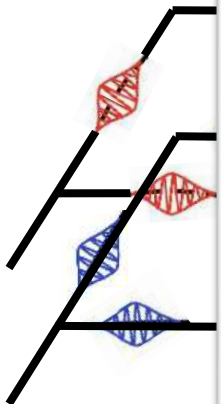

Quantum Mechanics

3, M4).
 and K “test masses” in non-
 ons).
 km circular orbit.
 vity gradient shifts by
 king atom positioning

Methods of operation.

Comments
Torsion balance
MICROSCOPE first results
MICROSCOPE full data
Atom Interferometry
and macroscopic corner cube (CC)
different elements
same element, fermion vs. boson
same element, different isotopes
10 m tower
STE-QUEST
under construction at CERN

Example of Open Questions in Fundamental Physics

... and how the Quantum Revolutions could help addressing them

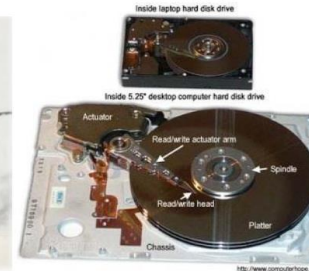
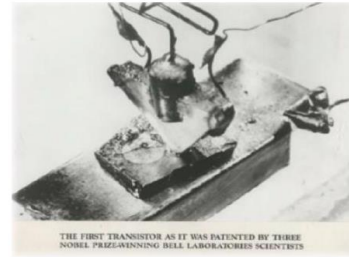

Planck's quantum theory

transistor

hard disk

laser

beginning of 20th century

1947

1954

1960



Albert Einstein (1879-1955)



Werner Heisenberg (1901-1976)



Erwin Schrödinger (1887-1961)

The first quantum revolution

Observation and macroscopic manifestation of quantum principles

Example of Open Questions in Fundamental Physics

... and how the Quantum Revolutions could help addressing them

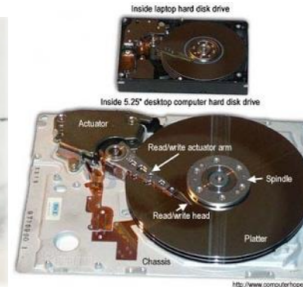

Planck's quantum theory

transistor

hard disk

laser

beginning of 20th century

1947

1954

1960

end 20th / beginning 21st



Richard Feynman
(1918–1988)



Serge Haroche

And also Alain Aspect, Charles Bennett,
Gilles Brassard, Artur Ekert, Peter Shor...

Control of single quantum particles
First quantum algorithms

The second quantum revolution

Active manipulation of single quantum particles and
interaction between multiple particles for applications

MORE ON ATOM INTERFEROMETRY CONCEPT

Possible Phase Shifts

Ramsey sequence (clock)

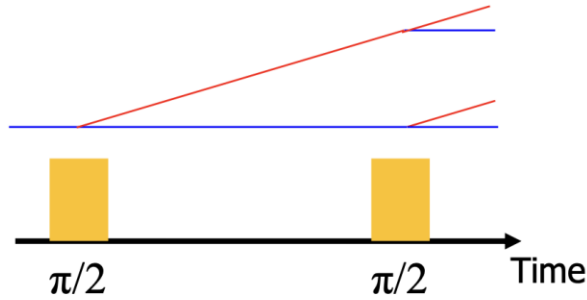

$$\Delta\phi = \phi_1 - \phi_2 = (\omega - \omega_A)T + kx_1 - kx_2 = (\omega - \omega_A)T + \underline{k v T}$$

- Measures velocity

Mach-Zehnder

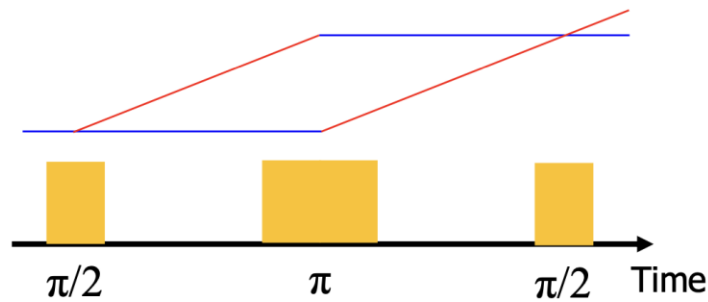

$$\Delta\phi = (\phi_1 - \phi_2) - (\phi_2 - \phi_3) = k v_1 T - k v_2 T = \underline{k a T^2}$$

- "Difference" of two Ramsey sequences
- Measures acceleration

"Double diamond"

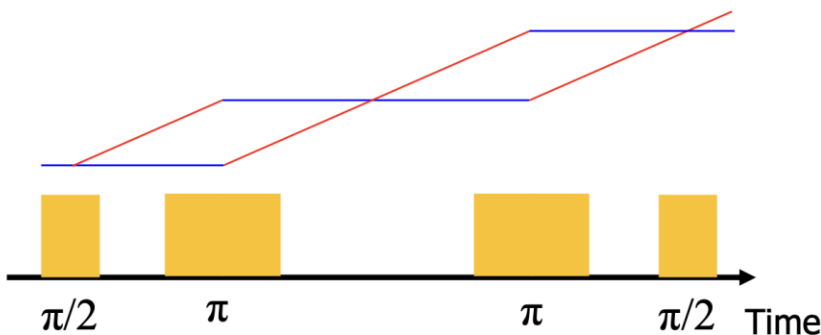

$$\Delta\phi = k a_1 T^2 - k a_2 T^2 = k \delta a T^3$$

- Difference of two MZ loops
- Measures acceleration gradient (in space and/or time)

General Relativistic Effects in Atom Interferometry

	GR Phase Shift	Size (rad)	Interpretation	NR Phase Shift
1.	$-k_{\text{eff}} g T^2$	$3. \times 10^8$	Newtonian gravity	$-k_{\text{eff}} g T^2$
2.	$-k_{\text{eff}} (\partial_r g) v_L T^3$	$-2. \times 10^3$	1st gradient	$-k_{\text{eff}} (\partial_r g) v_L T^3$
3.	$-\frac{7}{12} k_{\text{eff}} (\partial_r g) g T^4$	$9. \times 10^2$		$-\frac{7}{12} k_{\text{eff}} (\partial_r g) g T^4$
4.	$-3 k_{\text{eff}} g^2 T^3$	$-4. \times 10^1$	finite speed of light and	
5.	$-3 k_{\text{eff}} g v_L T^2$	$4. \times 10^1$	Doppler shift corrections	
6.	$-\frac{k_{\text{eff}}^2}{2m} (\partial_r g) T^3$	$-7. \times 10^{-1}$	1st gradient recoil	$-\frac{k_{\text{eff}}^2}{2m} (\partial_r g) T^3$
7.	$(\omega_{\text{eff}} - \omega_a) g T^2$	$-4. \times 10^{-1}$	detuning	
8.	$(2 - 2\beta - \gamma) k_{\text{eff}} g \phi T^2$	$-2. \times 10^{-1}$	GR (non-linearity)	
9.	$-\frac{3k_{\text{eff}}^2}{2m} g T^2$	$2. \times 10^{-2}$		
10.	$-\frac{7}{12} k_{\text{eff}} v_L^2 (\partial_r^2 g) T^4$	$8. \times 10^{-3}$	2nd gradient	$-\frac{7}{12} k_{\text{eff}} v_L^2 (\partial_r^2 g) T^4$
11.	$-\frac{35}{4} k_{\text{eff}} (\partial_r g) g v_L T^4$	$6. \times 10^{-4}$		
12.	$-4 k_{\text{eff}} (\partial_r g) v_L^2 T^3$	$-3. \times 10^{-4}$		
13.	$2 \omega_a g^2 T^3$	$2. \times 10^{-4}$		
14.	$2 \omega_a g v_L T^2$	$-2. \times 10^{-4}$		
15.	$-\frac{7k_{\text{eff}}^2}{12m} v_L (\partial_r^2 g) T^4$	$7. \times 10^{-6}$	2nd gradient recoil	$-\frac{7k_{\text{eff}}^2}{12m} v_L (\partial_r^2 g) T^4$
16.	$-12 k_{\text{eff}} g^2 v_L T^3$	$-7. \times 10^{-6}$		
17.	$-7 k_{\text{eff}} g^3 T^4$	$4. \times 10^{-6}$		
18.	$-5 k_{\text{eff}} g v_L^2 T^2$	$3. \times 10^{-6}$	GR (velocity-dependent force)	
19.	$(2 - 2\beta - \gamma) k_{\text{eff}} \partial_r (g \phi) v_L T^3$	$2. \times 10^{-6}$	GR 1st gradient	
20.	$\frac{7}{12} (4 - 4\beta - 3\gamma) k_{\text{eff}} \phi (\partial_r g) g T^4$	$-2. \times 10^{-6}$	GR	
21.	$(\omega_{\text{eff}} - \omega_a) (\partial_r g) v_L T^3$	$2. \times 10^{-6}$		
22.	$\frac{7}{12} (\omega_{\text{eff}} - \omega_a) (\partial_r g) g T^4$	$-1. \times 10^{-6}$		
23.	$-\frac{7}{12} (2 - 2\beta - \gamma) k_{\text{eff}} g^3 T^4$	$-3. \times 10^{-7}$	GR	
24.	$-\frac{7k_{\text{eff}}^2}{2m} (\partial_r g) v_L T^3$	$-2. \times 10^{-7}$		
25.	$-\frac{27k_{\text{eff}}^2}{8m} (\partial_r g) g T^4$	$2. \times 10^{-7}$		
26.	$\frac{k_{\text{eff}} \omega_a}{m} g T^2$	$-1. \times 10^{-7}$		
27.	$6(2 - 2\beta - \gamma) k_{\text{eff}} \phi g^2 T^3$	$5. \times 10^{-8}$	GR	
28.	$3 (\omega_{\text{eff}} - \omega_a) g^2 T^3$	$4. \times 10^{-8}$		
29.	$3 (\omega_{\text{eff}} - \omega_a) g v_L T^2$	$-4. \times 10^{-8}$		
30.	$6(1 - \beta) k_{\text{eff}} \phi g v_L T^2$	$3. \times 10^{-8}$	GR	

Dimopoulos et al, Phys.Rev.D78:042003,2008

Large Scale AI For Fundamental Physics

Pi and Pi/2 Pulses – Rabi Oscillation

Rabi oscillation between
 $|f\rangle$ and $|e\rangle$

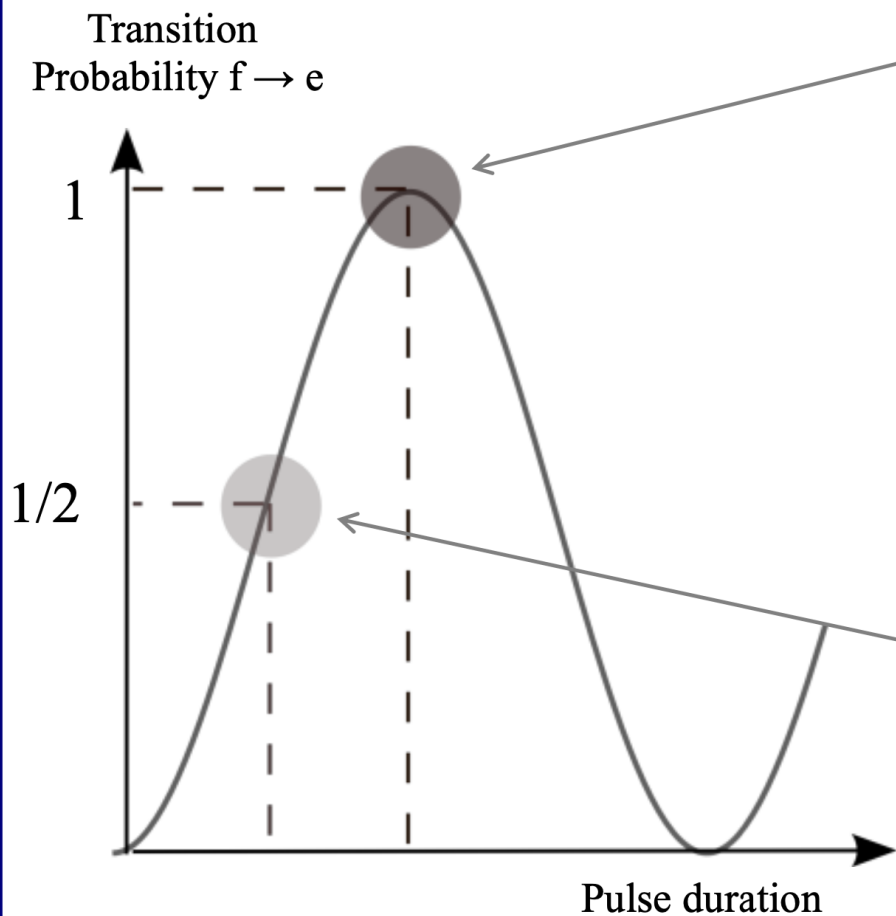

“ π ” pulse = mirror

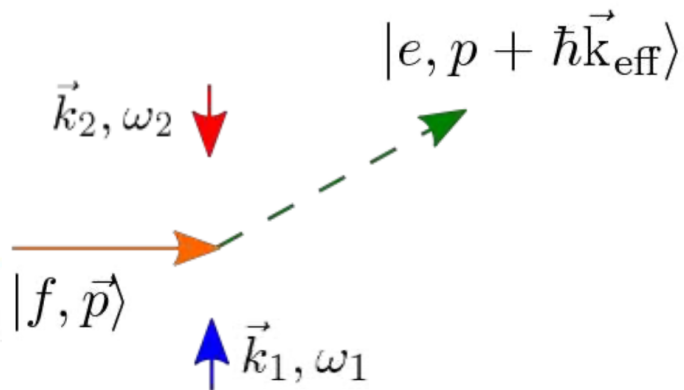

Imprint laser phase on atomic wave-function:

$$\varphi = \phi_1 - \phi_2 = \vec{k}_{\text{eff}} \cdot \vec{r}(t)$$

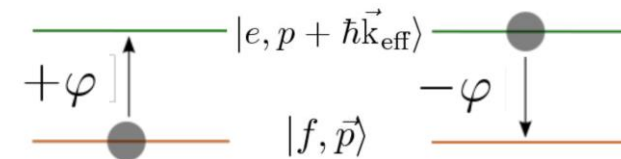

“ $\pi/2$ ” pulse = beam splitter

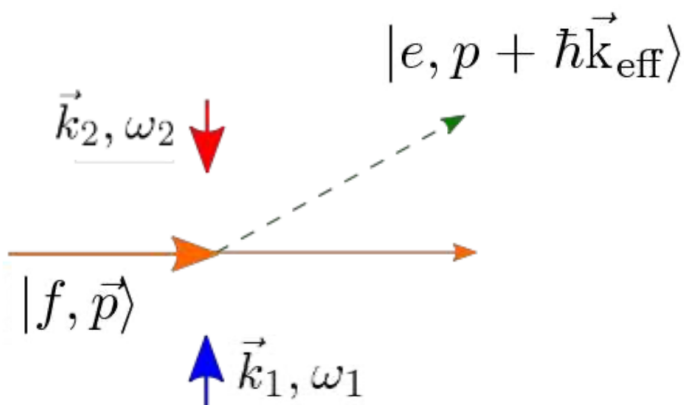

Momentum transfer (~ 1 cm/s)

$$k_{\text{eff}} = k_1 + k_2$$

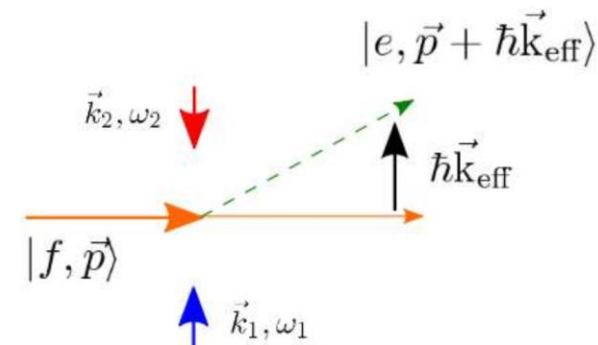

Mach-Zehnder Atom Interferometer – Phase shift

Assuming no other interactions like gravity, etc.

Atoms at rest:

At time before first Pulse:

$$\Phi_1 = 0, \quad \Phi_2 = 0$$

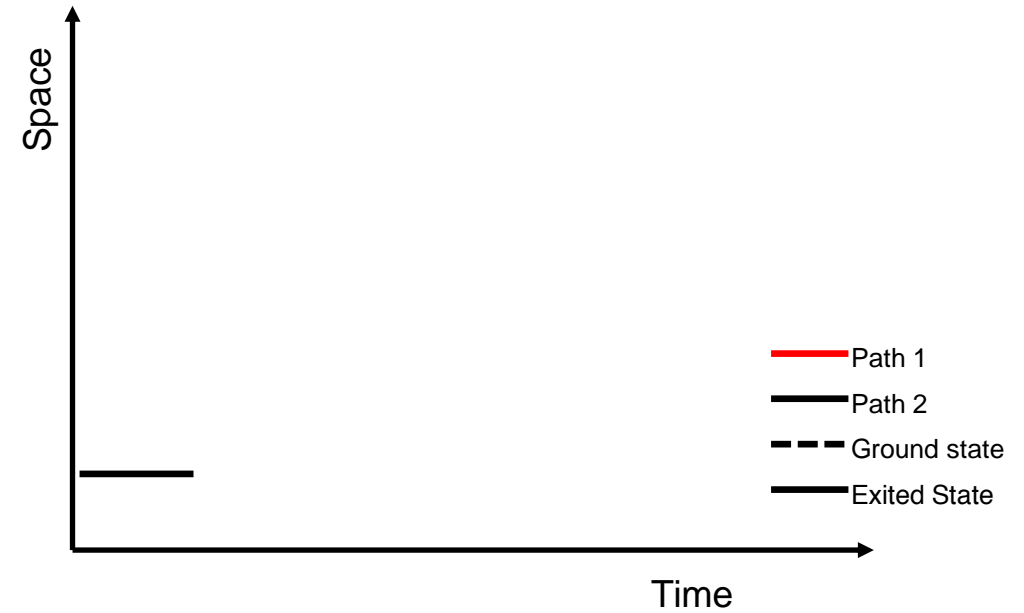

Mach-Zehnder Atom Interferometer – Phase shift

Assuming no other interactions like gravity, etc.

Atoms at rest:

At time before first Pulse:

$$\Phi_1 = 0, \quad \Phi_2 = 0$$

At time $T = 0$ of first $\pi/2$ Pulse:

$$\Phi_1 = \phi_1, \quad \Phi_2 = 0$$

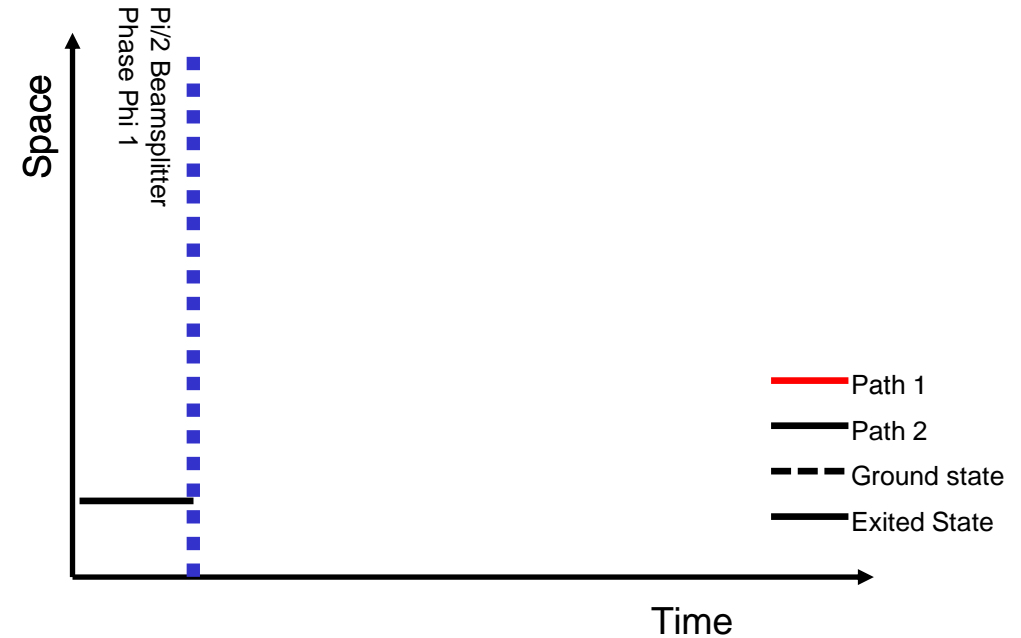

Mach-Zehnder Atom Interferometer – Phase shift

Assuming no other interactions like gravity, etc.

Atoms at rest:

At time before first Pulse:

$$\Phi_1 = 0, \quad \Phi_2 = 0$$

At time $T = 0$ of first $\pi/2$ Pulse:

$$\Phi_1 = \phi_1, \quad \Phi_2 = 0$$

At time $t = T$ just before the π mirror pulse $|1\rangle$ acquired the energy phase
 $-Et/\hbar = -\omega_a T$

$$\Phi_1 = \phi_1 - ET/\hbar, \quad \Phi_2 = 0$$

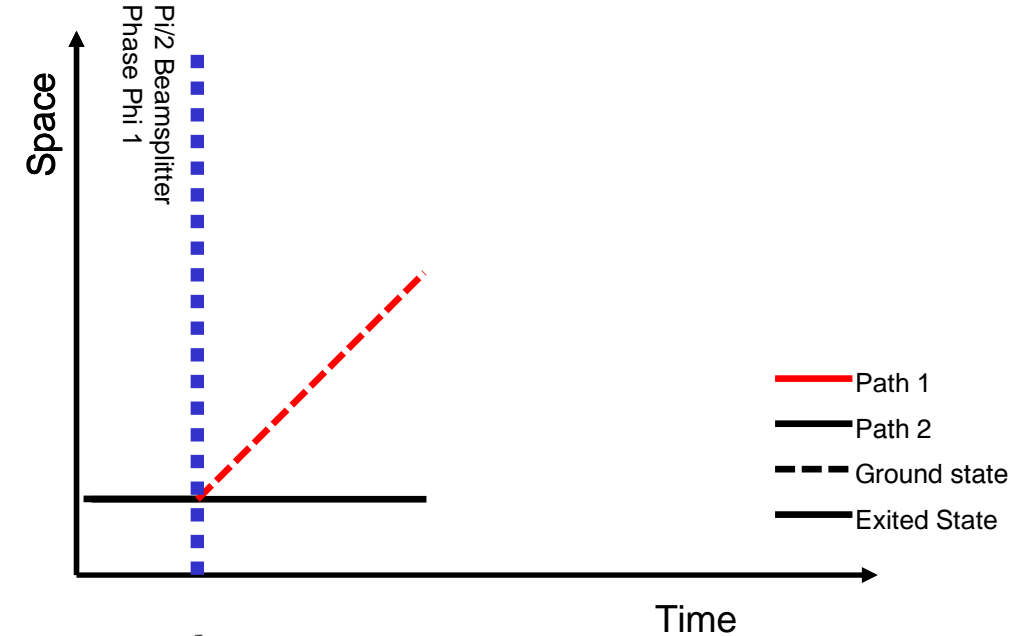

Mach-Zehnder Atom Interferometer – Phase shift

Assuming no other interactions like gravity, etc.

Atoms at rest:

At time before first Pulse:

$$\Phi_1 = 0, \quad \Phi_2 = 0$$

At time $T = 0$ of first $\pi/2$ Pulse:

$$\Phi_1 = \phi_1, \quad \Phi_2 = 0$$

At time $t = T$ just before the π mirror pulse $|1\rangle$ acquired the energy phase
 $-Et/\hbar = -\omega_a T$

$$\Phi_1 = \phi_1 - ET/\hbar, \quad \Phi_2 = 0$$

At time $t = T$ of the π Pulse:

$$\Phi_1 = \phi_1 - ET/\hbar - \phi_2, \quad \Phi_2 = \phi_2$$

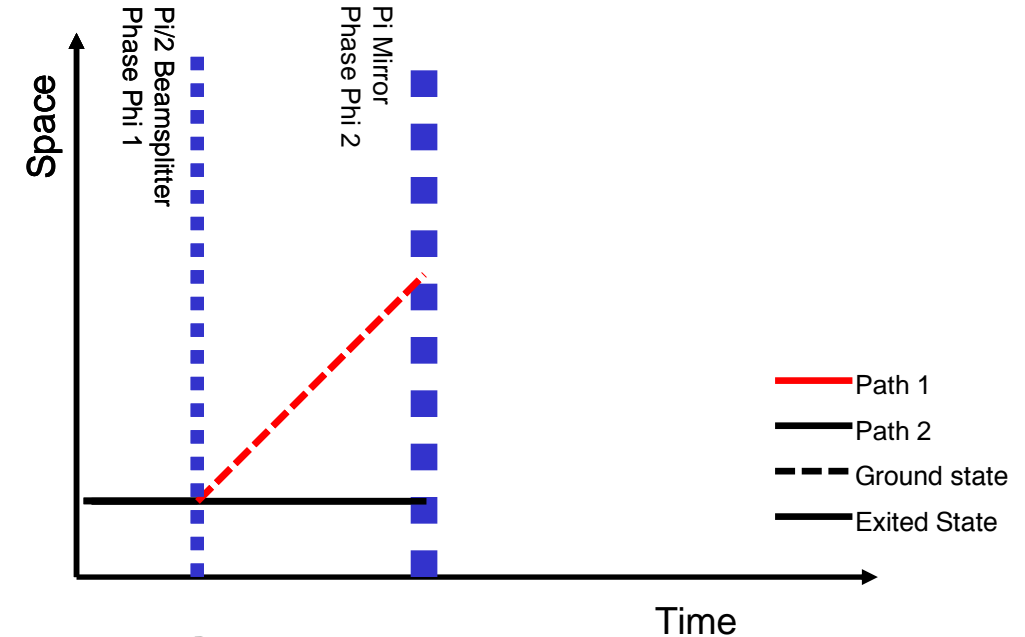

Mach-Zehnder Atom Interferometer – Phase shift

Assuming no other interactions like gravity, etc.

At time $t = 2T$ just before the next $\pi/2$ mirror pulse:

$$\Phi_1 = \phi_1 - ET/\hbar - \phi_2, \quad \Phi_2 = \phi_2 - ET/\hbar$$

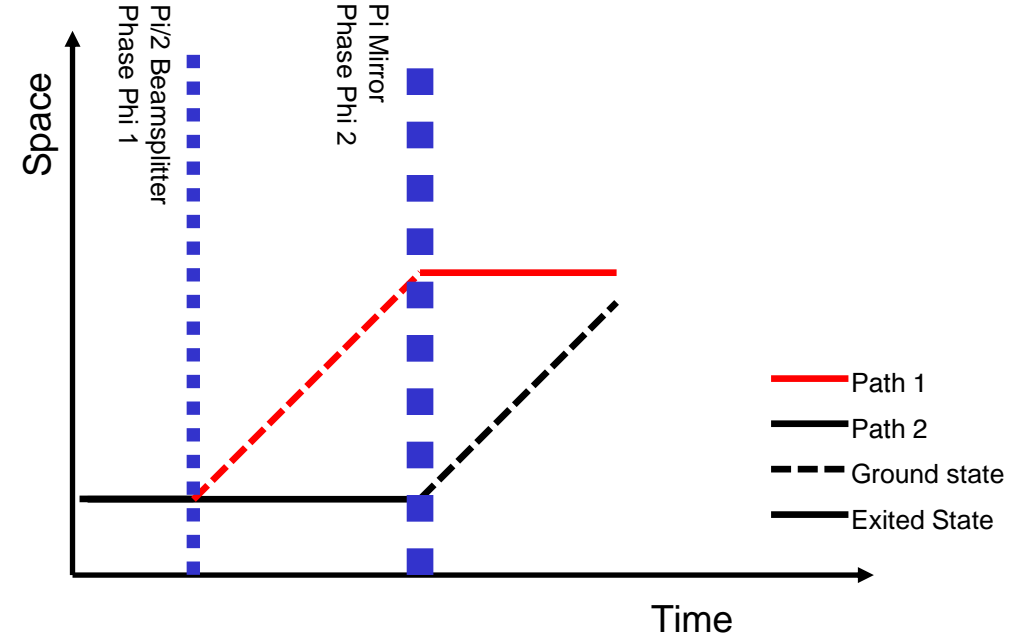

Mach-Zehnder Atom Interferometer – Phase shift

Assuming no other interactions like gravity, etc.

At time $t = 2T$ just before the next $\pi/2$ mirror pulse:

$$\Phi_1 = \phi_1 - ET/\hbar - \phi_2, \quad \Phi_2 = \phi_2 - ET/\hbar$$

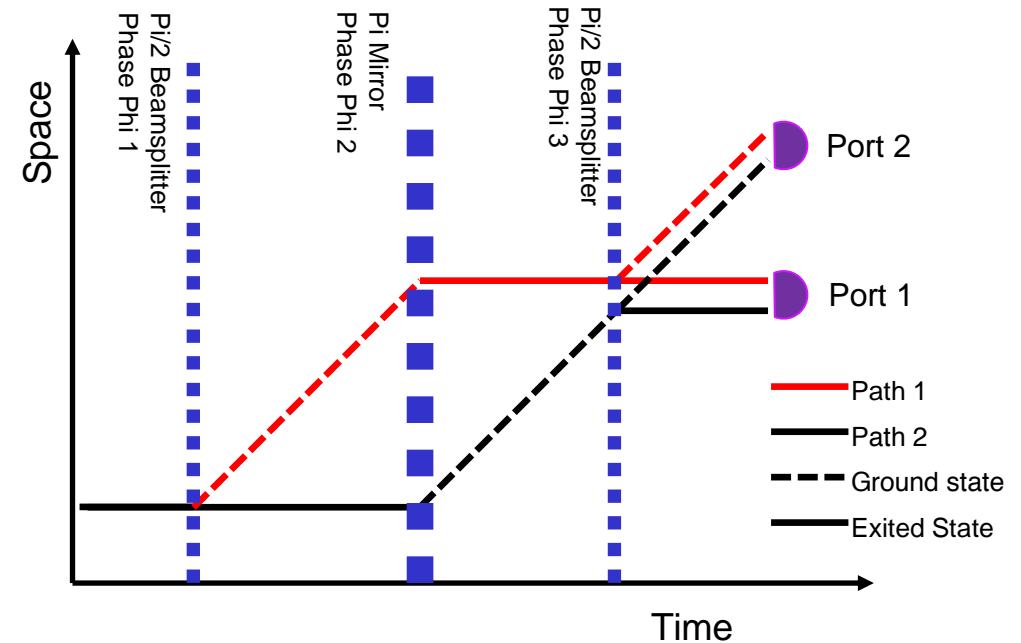

At time $t = 2T$ just after the next $\pi/2$ mirror pulse, we actually split in four components:

At $|0\rangle$ port:

$$\Phi_1 = \phi_1 - ET/\hbar - \phi_2, \quad \Phi_2 = \phi_2 - ET/\hbar - \phi_3$$

At $|1\rangle$ port:

$$\Phi_1 = \phi_1 - ET/\hbar - \phi_2 + \phi_3, \quad \Phi_2 = \phi_2 - ET/\hbar$$

Mach-Zehnder Atom Interferometer – Phase shift

Assuming no other interactions like gravity, etc.

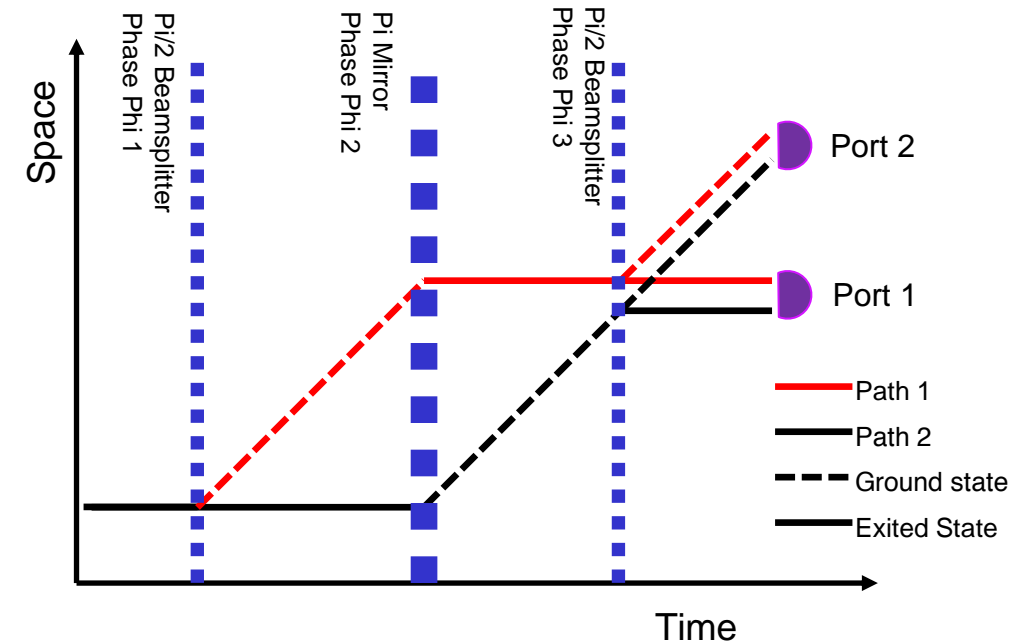

Therefore, the phase difference $\Delta\phi = \Phi_1 - \Phi_2$ is:

$$\Phi_1 - \Phi_2 = (\phi_1 - ET/\hbar - \phi_2) - (\phi_2 - ET/\hbar - \phi_3) = \phi_1 - 2\phi_2 + \phi_3$$

or

$$\Phi_1 - \Phi_2 = (\phi_1 - ET/\hbar - \phi_2 + \phi_3) - (\phi_2 - ET/\hbar) = \phi_1 + \phi_3 - 2\phi_2$$

MZ Acceleration Phase Shift

Acceleration phase shift

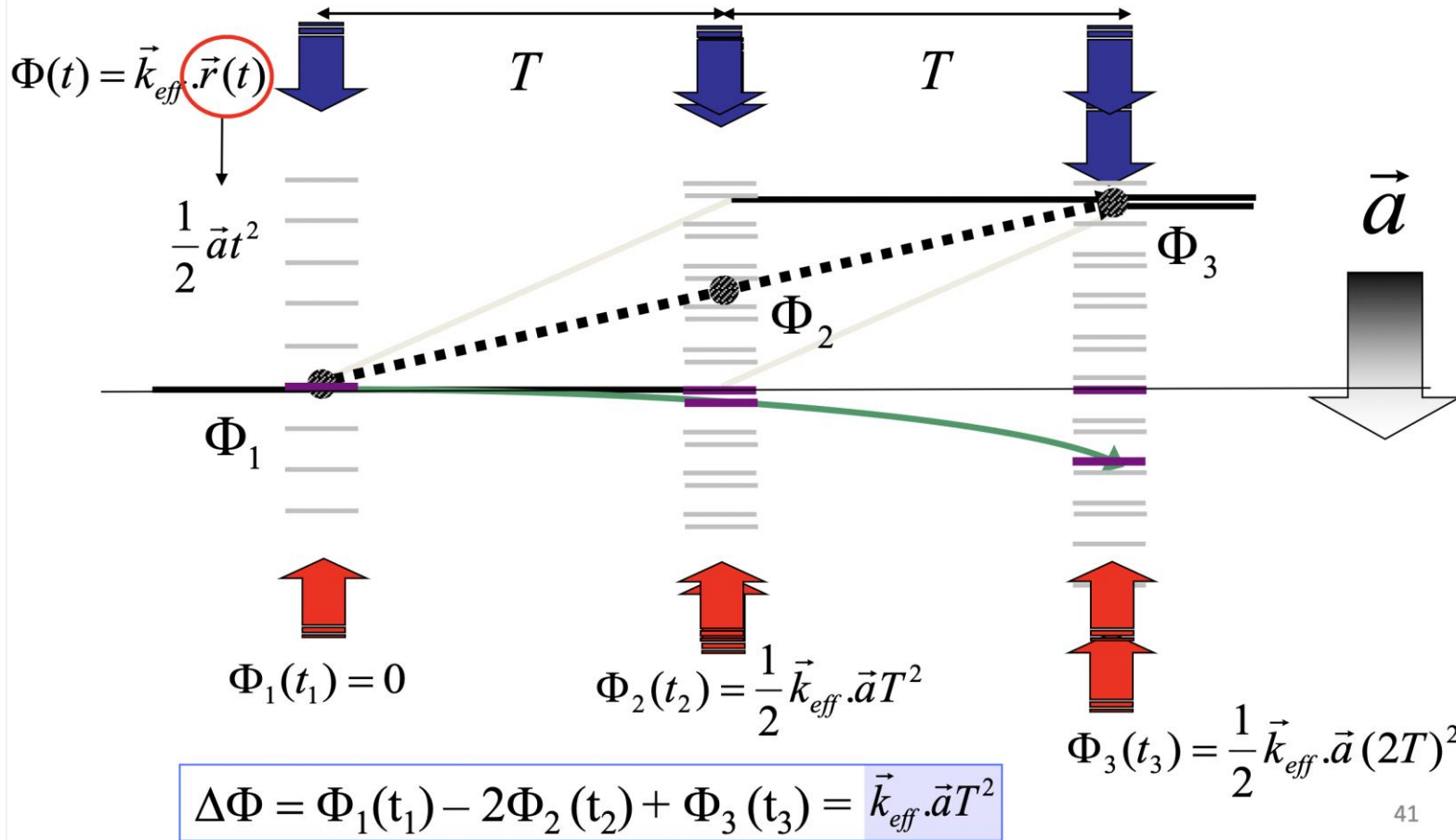

Different Phase Shifts for Different Interactions

Laser phase gets imprinted

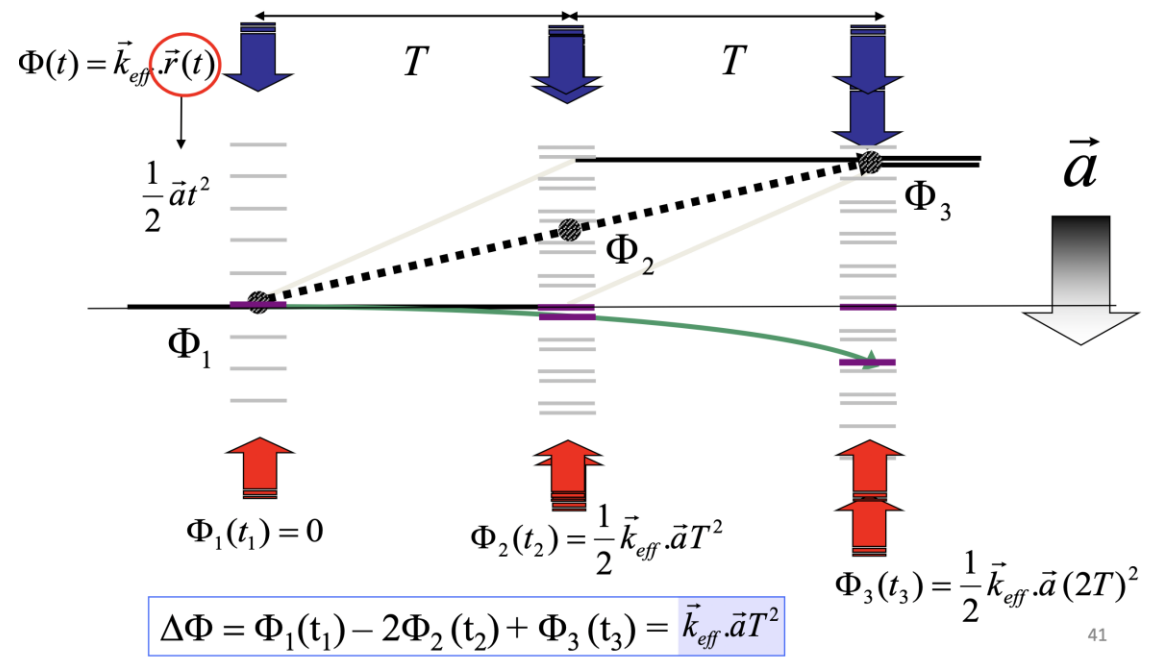
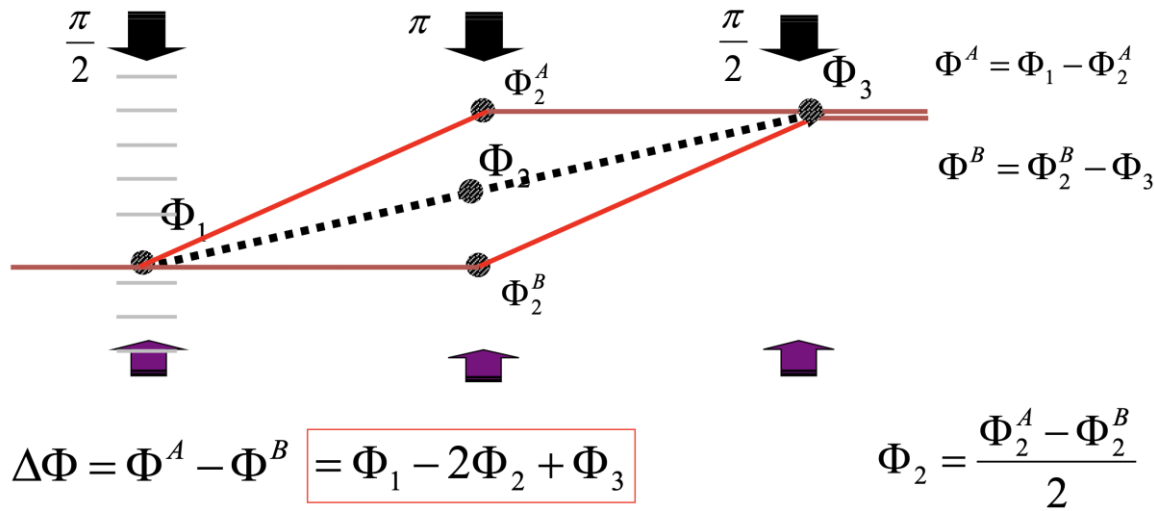
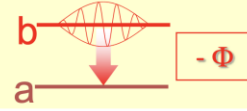
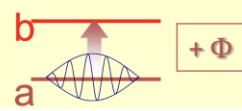

Large Scale AI For Fundamental Physics

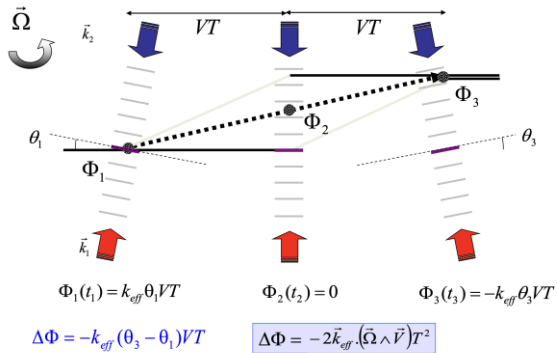

$$\Delta\Phi = \Phi_1^{eff} - 2\Phi_2^{eff} + \Phi_3^{eff}$$

$$\Phi_i^{eff}(t) = \vec{k}_i^{eff} \cdot \vec{r}_i(t)$$

STE-QUEST

STE-QUEST (M-Class Mission Proposal)

STE-QUEST

Space Time Explorer and QUantum Equivalence principle Space Test

A M-class mission proposal in response to the 2022 call in ESA's science program

Core Team:

- Angelo Bassi, Department of Physics, University of Trieste, and INFN - Trieste Section, *Italy*
- Kai Bongs, Midlands Ultracold Atom Research Centre, School of Physics and Astronomy University of Birmingham, *United Kingdom*
- Philippe Bouyer, LP2N, Université Bordeaux, IOGS, CNRS, Talence, *France*
- Claus Braxmaier, Institute of Microelectronics, Ulm University and Institute of Quantum Technologies, German Aerospace Center (DLR), *Germany*
- Oliver Buchmueller, High Energy Physics Group, Blackett Laboratory, Imperial College London, London, *United Kingdom*
- Maria Luisa (Marilyn) Chiofalo, Physics Department "Enrico Fermi" University of Pisa, and INFN-Pisa *Italy*
- John Ellis, Physics Department, King's College London, *United Kingdom*
- Naceur Gaaloul, Institute of Quantum Optics, Leibniz University of Hanover, *Germany*
- Aurélien Hees, SYRTE, Observatoire de Paris-PSL, CNRS, Sorbonne Université, LNE, Paris, *France*
- Philippe Jetzer, Department of Physics, University of Zurich, *Switzerland*
- Steve Lecomte, Centre Suisse d'Electronique et de Microtechnique (CSEM), Neuchâtel, *Switzerland*
- Gilles Métris, Université Côte d'Azur, Observatoire de la Côte d'Azur, CNRS, IRD, Géoazur, *France*
- Ernst M. Rasel, Institute of Quantum Optics, Leibniz University of Hanover, *Germany*
- Thilo Schuldt, German Aerospace Center (DLR), Institute of Quantum Technologies, Ulm *Germany*
- Carlos F. Sopuerta, Institute of Space Sciences (ICE, CSIC), Institute of Space Studies of Catalonia (IEEC), *Spain*
- Guglielmo M. Tino, Dipartimento di Fisica e Astronomia and LENS, Università di Firenze, INFN, CNR *Italy*
- Wolf von Klitzing, Institute of Electronic Structure and Laser, Foundation for Research and Technology Hellas, *Greece*
- Lisa Wörner, German Aerospace Center (DLR), Institute of Quantum Technologies, Ulm *Germany*
- Nan Yu, Jet Propulsion Laboratory, California Institute of Technology, Pasadena, CA 91109, *USA*
- Martin Zelan, Measurement Science and Technology, RISE Research Institutes of Sweden, Borås, *Sweden*

Strong UK representation
in STE-QUEST Core
Team.

All are also core
members of AION

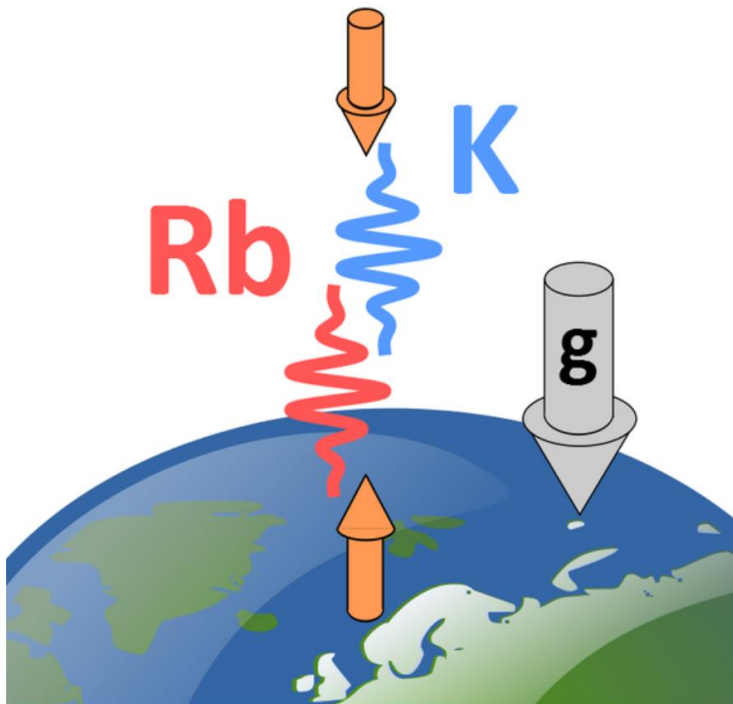

STE-QUEST: An M-class Cold Atom mission to probe gravity, dark matter and quantum mechanics

Science Goals: Equivalent Principal at 1E-17, Ultra-Light Dark Matter, Test of Quantum Mechanics

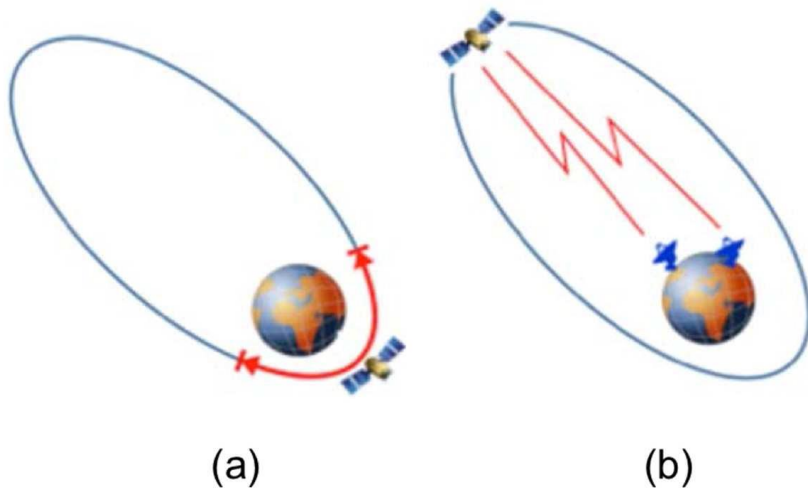

Large Scale AI For Fundamental Physics

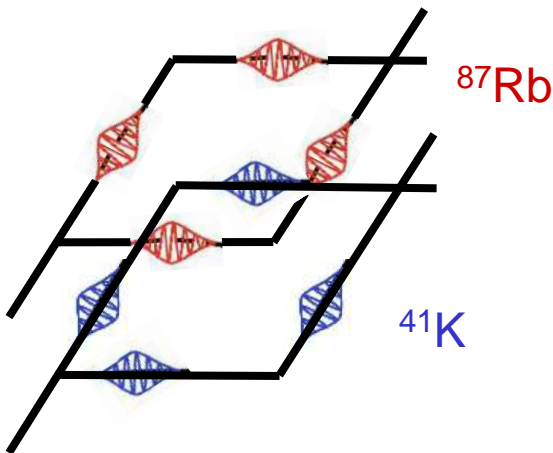

- Based on STE-QUEST proposals (M3, M4).
- Double atom interferometer with Rb and K “test masses” in non-classical states (quantum superpositions).
- Optimized for UFF test. Assume 700 km circular orbit.
- Apply recent results on controlling gravity gradient shifts by offsetting laser frequencies, thus relaxing atom positioning requirements by factor >100.
- **Reaches 1E-17 target after 18 months of operation.**

Class	Elements	η	Year [ref]	Comments
Classical	Be - Ti	2×10^{-13}	2008	Torsion balance
	Pt - Ti	1×10^{-14}	2017	MICROSCOPE first results
	Pt - Ti	(10^{-15})	2022+	MICROSCOPE full data
Hybrid	^{133}Cs - CC	7×10^{-9}	2001	Atom Interferometry
	^{87}Rb - CC	7×10^{-9}	2010	and macroscopic corner cube (CC)
Quantum	^{39}K - ^{87}Rb	3×10^{-7}	2020	different elements
	^{87}Sr - ^{88}Sr	2×10^{-7}	2014	same element, fermion vs. boson
	^{85}Rb - ^{87}Rb	3×10^{-8}	2015	same element, different isotopes
	^{85}Rb - ^{87}Rb	3.8×10^{-12}	2020	10 m tower
	^{41}K - ^{87}Rb	(10^{-17})	2037	STE-QUEST
Antimatter	$\bar{\text{H}}$ - H	(10^{-2})	2023+	under construction at CERN

STE-QUEST: An M-class Cold Atom mission to probe gravity, dark matter and quantum mechanics

Science Goals: Equivalent Principal at 1E-17, Ultra-Light Dark Matter, Test of Quantum Mechanics

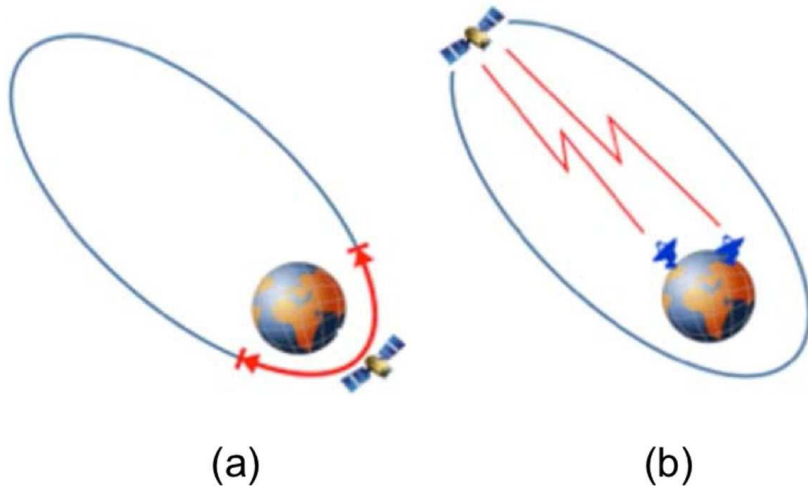

- Based on STE-QUEST proposals (M3, M4).
- Double atom interferometer with Rb and K “test masses” in non-classical states (quantum superpositions).
- Optimized for UFF test. Assume 700 km circular orbit.
- Apply recent results on controlling gravity gradient shifts by offsetting laser frequencies, thus relaxing atom positioning requirements by factor >100.
- **Reaches 1E-17 target after 18 months of operation.**

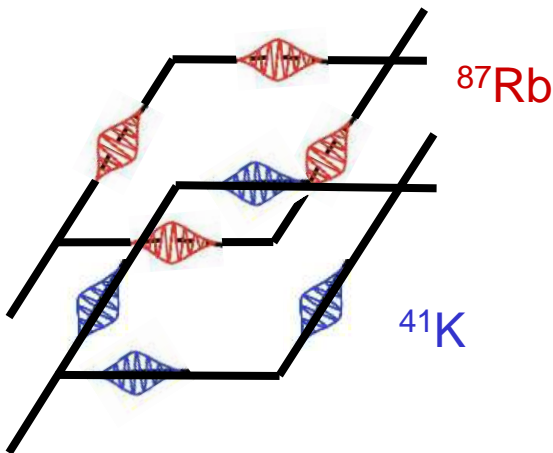

Class	Elements	η	Year [ref]	Comments
Classical	Be - Ti	2×10^{-13}	2008	Torsion balance
	Pt - Ti	1×10^{-14}	2017	MICROSCOPE first results
	Pt - Ti	(10^{-15})	2022+	MICROSCOPE full data
Hybrid	^{133}Cs - CC	7×10^{-9}	2001	Atom Interferometry
	^{87}Rb - CC	7×10^{-9}	2010	and macroscopic corner cube (CC)
Quantum	^{39}K - ^{87}Rb	3×10^{-7}	2020	different elements
	^{87}Sr - ^{88}Sr	2×10^{-7}	2014	same element, fermion vs. boson
	^{85}Rb - ^{87}Rb	3×10^{-8}	2015	same element, different isotopes
	^{85}Rb - ^{87}Rb	3.8×10^{-12}	2020	10 m tower
	^{88}Sr - ^{88}Sr	5.7×10^{-13}	2024	AION 10m
	^{88}Sr - ^{88}Sr	$< 10^{-15}$	2030	AION/MAGIS 100m
	^{41}K - ^{87}Rb	(10^{-17})	2037	STE-QUEST
Antimatter	$\bar{\text{H}}$ - H	(10^{-2})	2023+	under construction at CERN

STE-QUEST: An M-class Cold Atom mission to probe gravity, dark matter and quantum mechanics

Science Goals: Equivalent Principal at 1E-17, Ultra-Light Dark Matter, Test of Quantum Mechanics

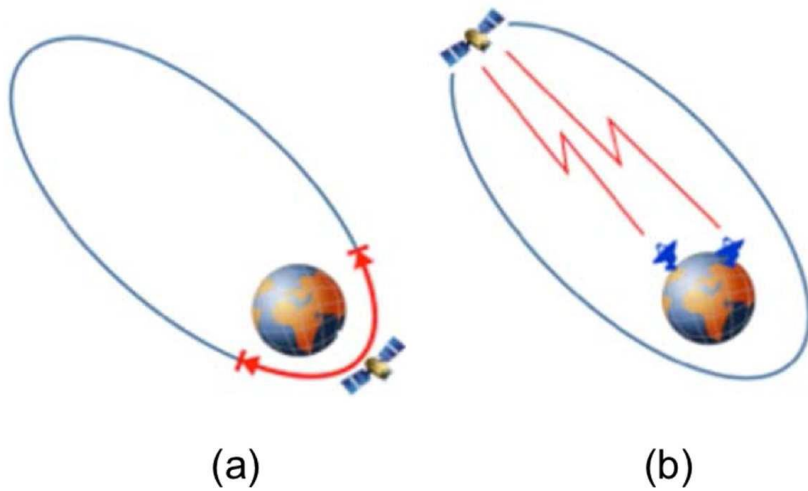

- Based on STE-QUEST proposals (M3, M4).
- Double atom interferometer with Rb and K “test masses” in non-classical s
- Optimized
- Apply rec
- offsetting
- requireme

State-of-the-art conventional sensors (electrostatic accelerometers) e.g. used for Earth Observation are limited by around $\eta \sim 1E-11$ (acceleration sensitivity)

• **Reaches**

Class	Elements	η	Year [ref]	Comments
Classical	Be - Ti	2×10^{-13}	2008	Torsion balance
	Pt - Ti	1×10^{-14}	2017	MICROSCOPE first results
	Pt - Ti	(10^{-15})	2022+	MICROSCOPE full data
Hybrid	^{133}Cs - CC	7×10^{-9}	2001	Atom Interferometry
	^{87}Rb - CC	7×10^{-9}	2010	and macroscopic corner cube (CC)
Quantum	^{39}K - ^{87}Rb	3×10^{-7}	2020	different elements
	^{87}Sr - ^{88}Sr	2×10^{-7}	2014	same element, fermion vs. boson
	^{85}Rb - ^{87}Rb	3×10^{-8}	2015	same element, different isotopes
	^{85}Rb - ^{87}Rb	3.8×10^{-12}	2020	10 m tower
	^{88}Sr - ^{88}Sr	5.7×10^{-13}	2024	AION 10m
	^{88}Sr - ^{88}Sr	$< 10^{-15}$	2030	AION/MAGIS 100m
	^{41}K - ^{87}Rb	(10^{-17})	2037	STE-QUEST
Antimatter	$\bar{\text{H}}$ - H	(10^{-2})	2023+	under construction at CERN

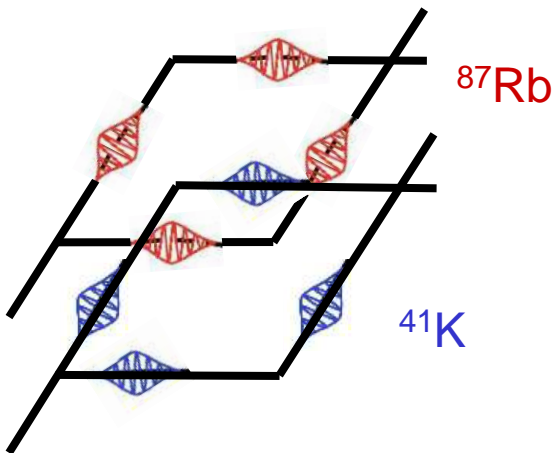

Large Scale AI For Fundamental Physics

STE-QUEST Workshop on May 17/18

STE-QUEST: An M-class Cold Atom mission to probe gravity, dark matter and quantum mechanics is now open at:

<https://indico.cern.ch/event/1138902/registrations/>

The workshop will take place as a virtual event on zoom on May 17/18.

<https://indico.cern.ch/event/1138902/>

- This workshop follows our Community Workshop & Roadmap for Cold Atoms in Space and is the next step in our community building process to define, develop and promote important milestones of our Community Roadmap, specifically the STE-QUEST M-class mission proposal now being considered by ESA.
- This event will bring together the cold atom, astrophysics, cosmology, and fundamental physics communities to discuss the science opportunities of this M-class mission proposal. Further information about the workshop scope is listed below.
- **Registering on the link provided above will enable you to attend the virtual workshop event and to keep informed about the continuing development of a full mission proposal that will follow it.**

ESA SENIOR RECOMMENDATIONS VOYGAE2050

Voyage 2050

Final recommendations from
the Voyage 2050 Senior Committee

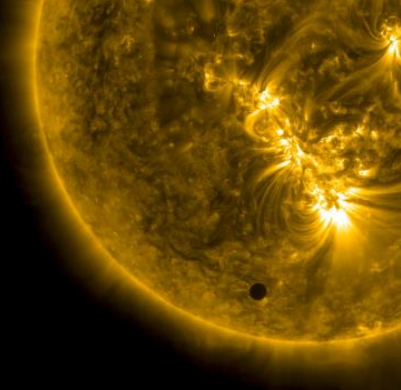

Large missions:

- Moons of the Giant Planets
- Exoplanets
- **New Physical Probes of the Early Universe:**
Fundamental physics and astrophysics

Possible Medium missions:

... **QM & GR (cold atoms?)**

Technology development recommendations for Cold Atom Interferometry

- for gravitational wave detectors in new wavebands ..., detectors for dark matter candidates, sensitive clock tests of general relativity, tests of wave function collapse ...
- must reach high technical readiness level, be superior to classical technologies
- start with atomic clocks, on free-flyer or ISS?

What M-mission to propose?



“Per audacia ad astra”

A coordinated three-fold response of the community to the Voyage 2050 recommendations:

- **A letter to ESA’s Director of Science, Guenther Hasinger:**
 - to raise awareness in ESA that the community is prepared to organise itself and to work actively with ESA, as it shapes a roadmap for a Cold Atom technology in space development programme
- **A community workshop in September:**
 - This event brought together the cold atom, astrophysics, cosmology, fundamental physics, and earth observation communities to formulate a road-map for the development programme,
- **A Workshop Summary and Road-map Document**
 - As input input to ESA and national space agencies on how to structure a Cold atoms in Space programme and what priorities could be established.

CERN AION100 SITE EXPLORATION WITH PBC

Introduction

EM Noise Levels

Slides from Sergio Calatroni (TE-VSC and PBC)

- **AION-100 experiment is an ion interferometer, proposed to be installed in the PX46 pit**
- **Feasibility study under way, with the support of the Physics Beyond Collider study - Technology Working Group. Aiming for official letter of intent at the end of the year.**
- **For info of other feasibility studies under way for AION-100: <https://indi.to/RkZdN>**
- **Need to measure EM background noise (1 mHz – 100 kHz) at the top (few meters below the steel lid) and at the bottom of PX46 during machine operation, using fluxgates up to 1-3 kHz, and 3D pick-up coils for the high frequency spectrum**
- **Choice of a closed plastic tube installed in the lid, after drilling, for hosting the probes**
- **Installation procedure approved by LMC: <https://edms.cern.ch/document/2710516/1.0>**
- **Many thanks to all services and people involved for the support: everybody was fully motivated to help**

AION-100

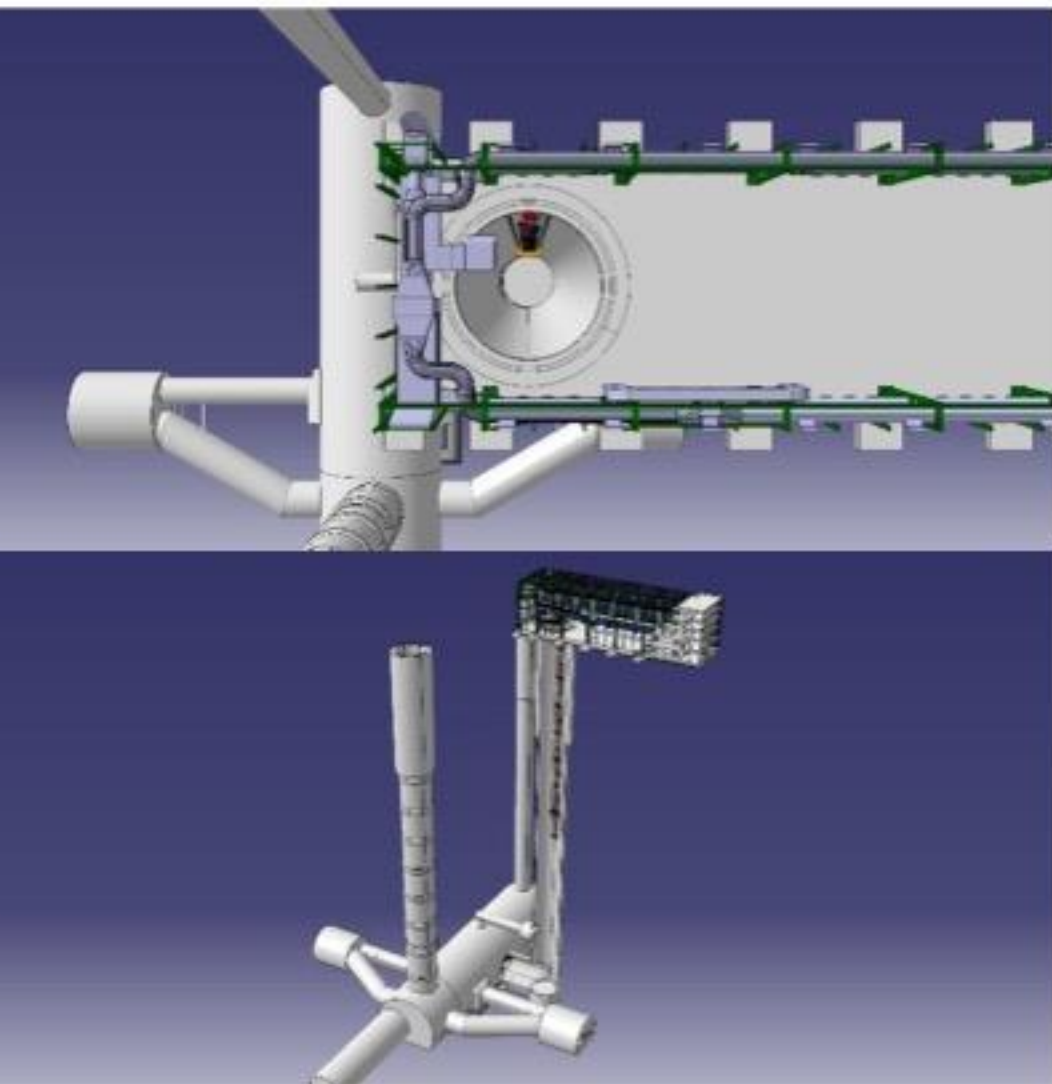

Location of AION-100

Drilling location



The tube (thanks to EN-MME)



PP plastic, closed at bottom
225 mm outer diameter
199,4 mm inner diameter
5000 mm length
Al flange for support

Installation (thanks to EN-ACE, EN-HE, EN-CV)



Ready for inserting the probes

Measurement location at the bottom of the PX46 shaft, UX45 building

Slides from Marco Buzio, Mariano Pentella, Daniel Valuch

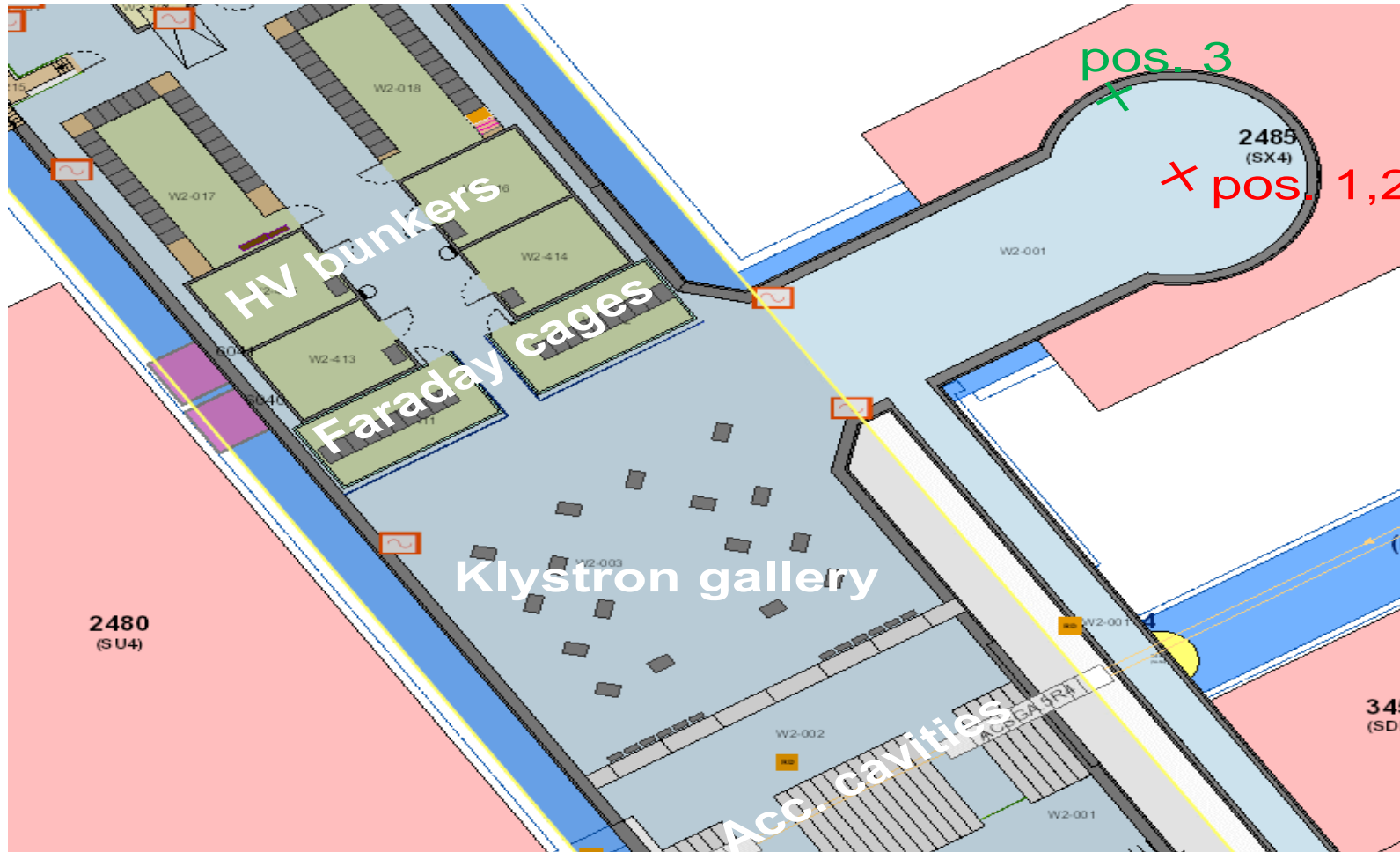

Measurement location at the bottom of the PX46 shaft, UX45 cavern



ATION-100 at CERN – Site Investigation

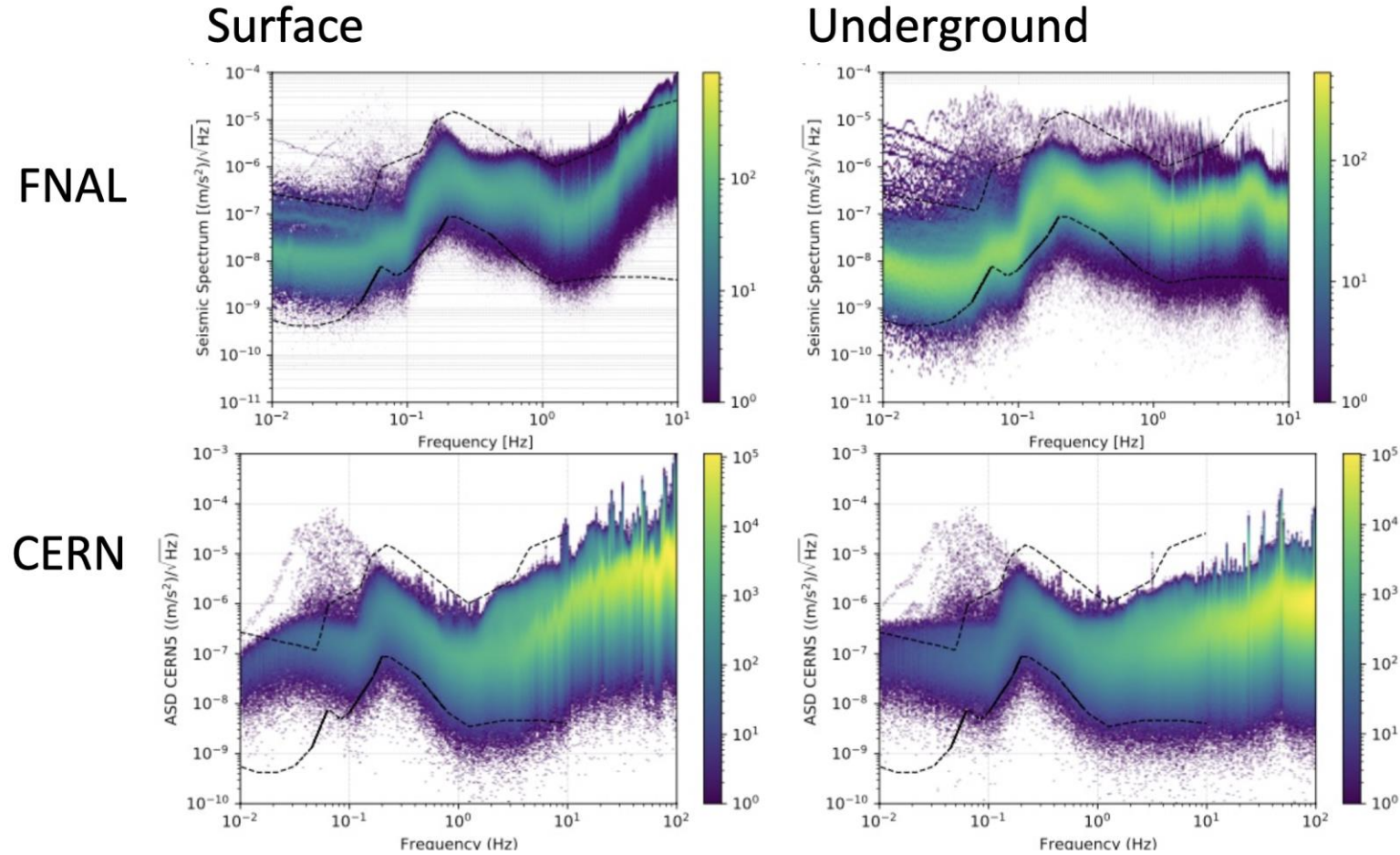

General view of LHC Point 4

Possible layout in PX46 shaft

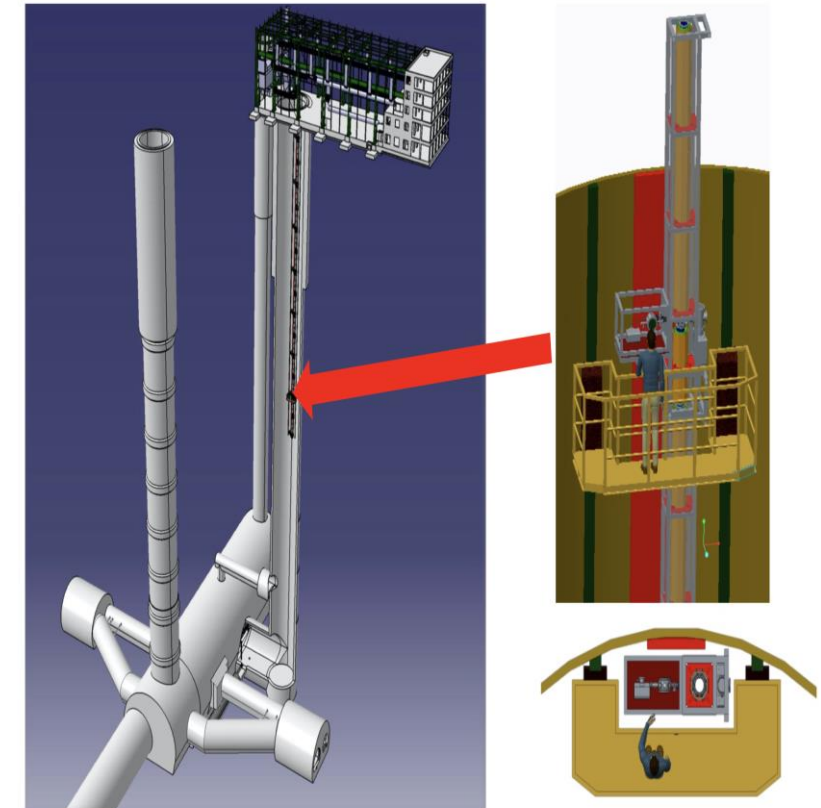

Spectrum similar to that measured at Fermilab for MAGIS

Location: bottom of the PX46 shaft. Systems in UX45 running

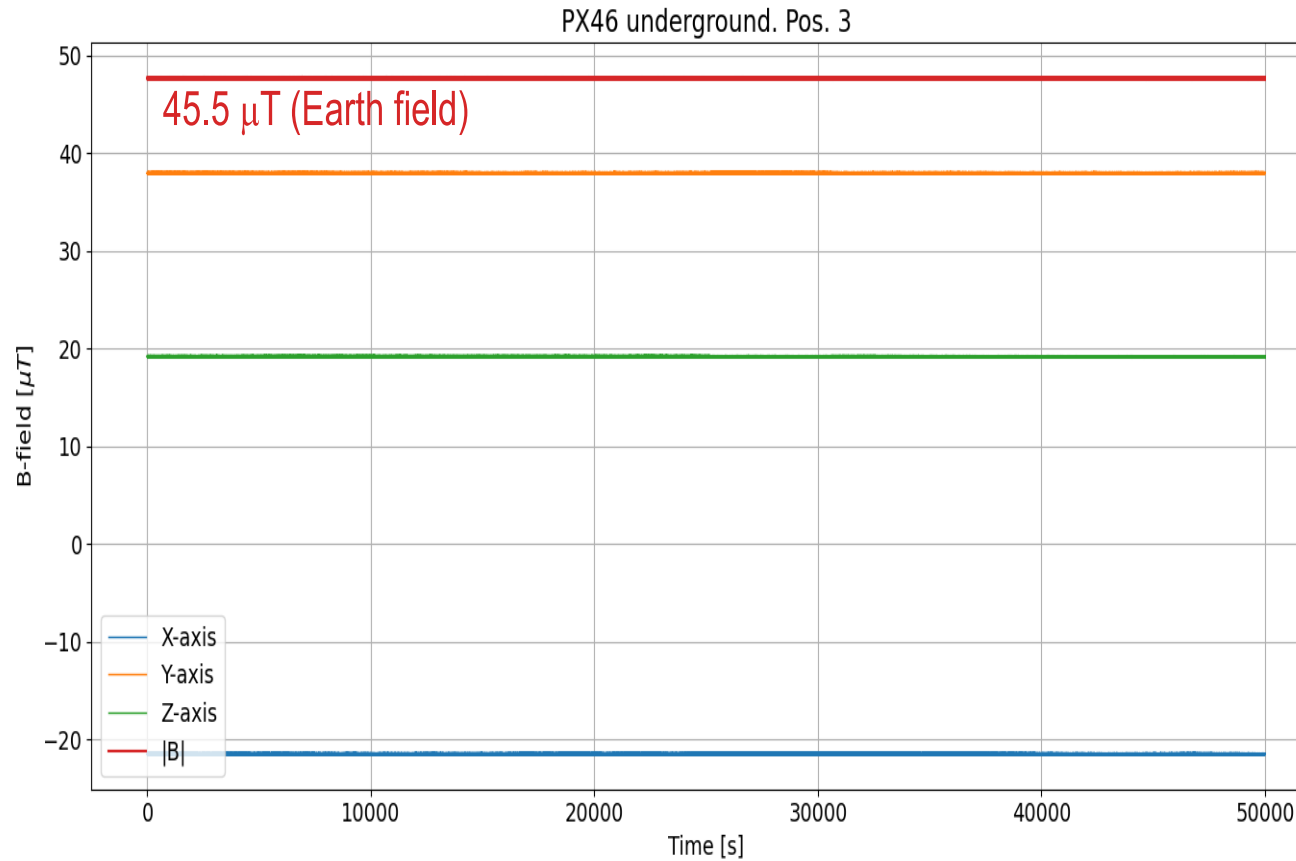

Location 3, wall of PX46. Quiet, Earth field for scale

Location: bottom of the PX46 shaft. Systems in UX45 running

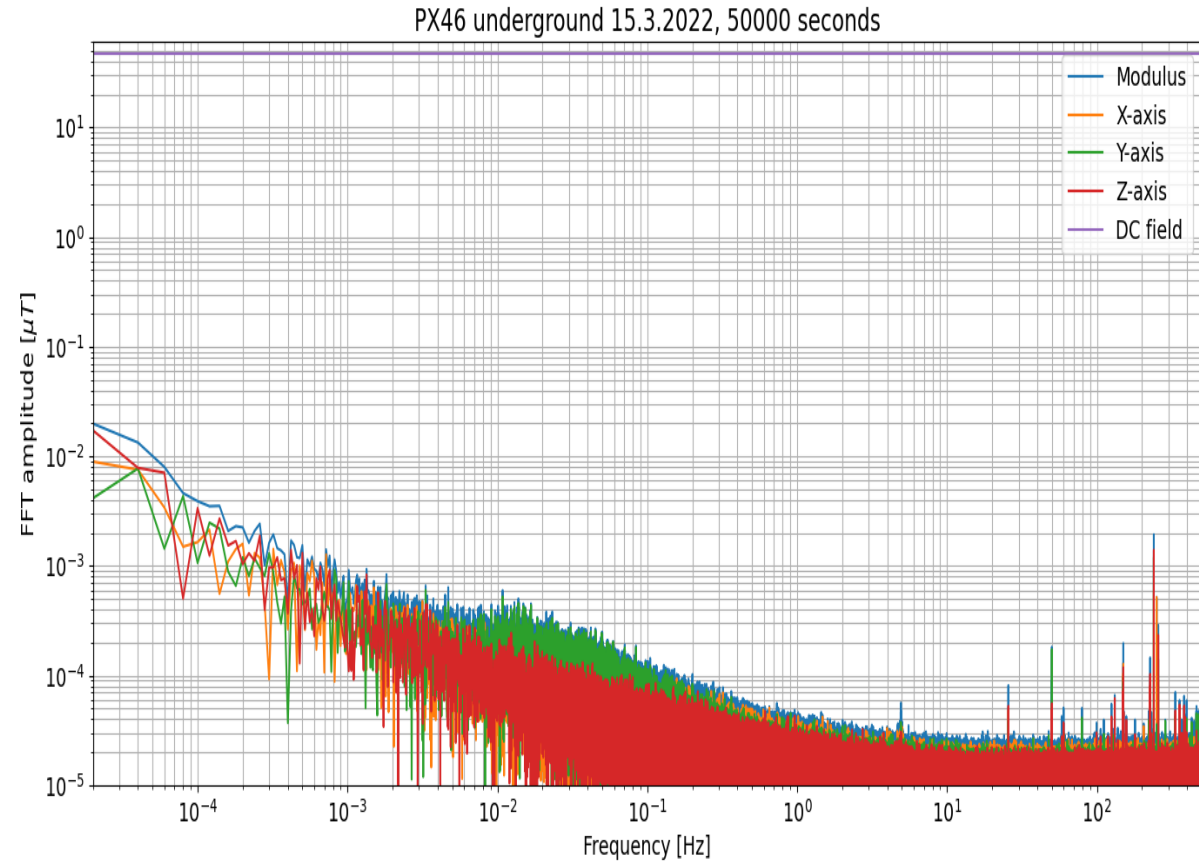

Location 3, wall of PX46. Earth (DC) field for scale

Location: bottom of the PX46 shaft. Systems in UX45 running

Location: bottom of the PX46 shaft. Systems in UX45 running

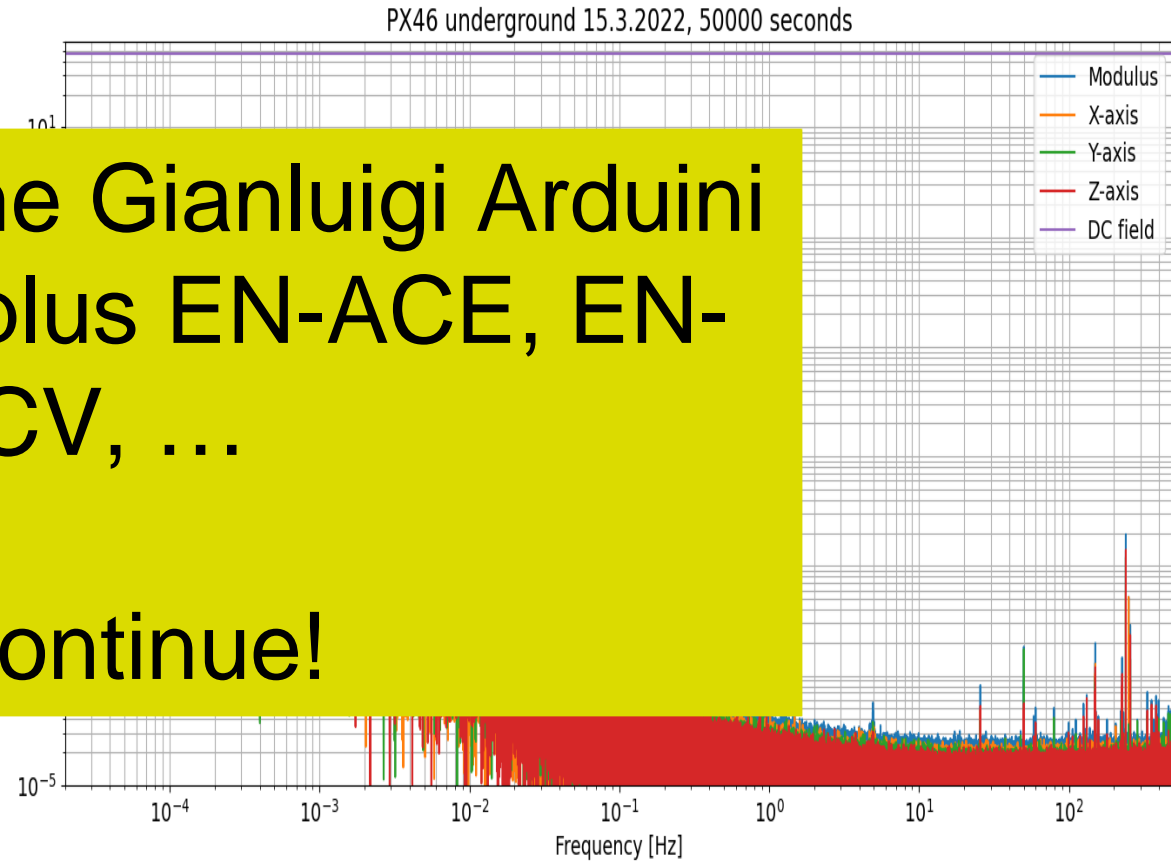
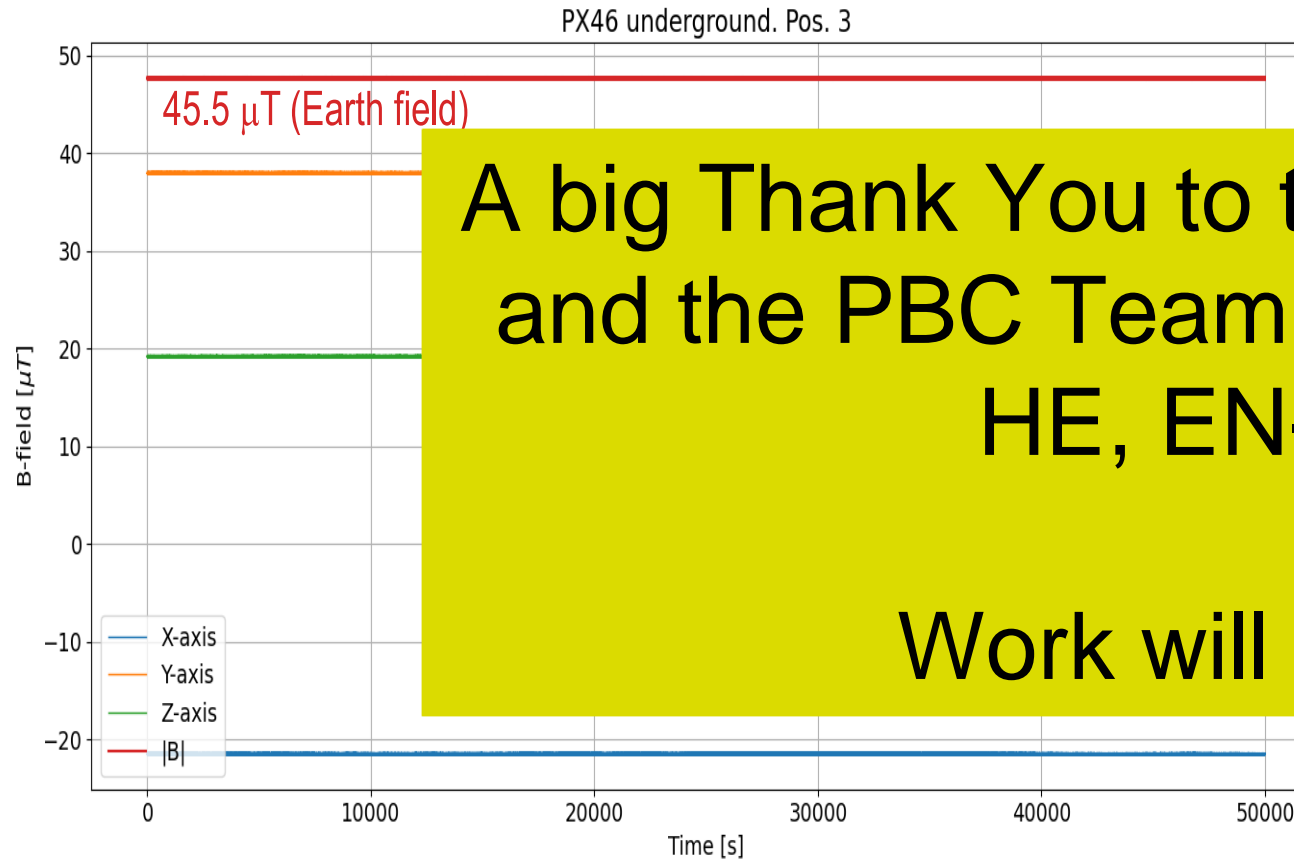

A big Thank You to the Gianluigi Arduini and the PBC Team plus EN-ACE, EN-HE, EN-CV, ...

Work will continue!

Location 3, wall of PX46. Quiet, Earth field for scale

Location 3, wall of PX46. Earth (DC) field for scale

**APPLICATIONS IN OTHER FIELDS, SUCH AS
QUANTUM COMPUTING.**

Quantum Computing & AION

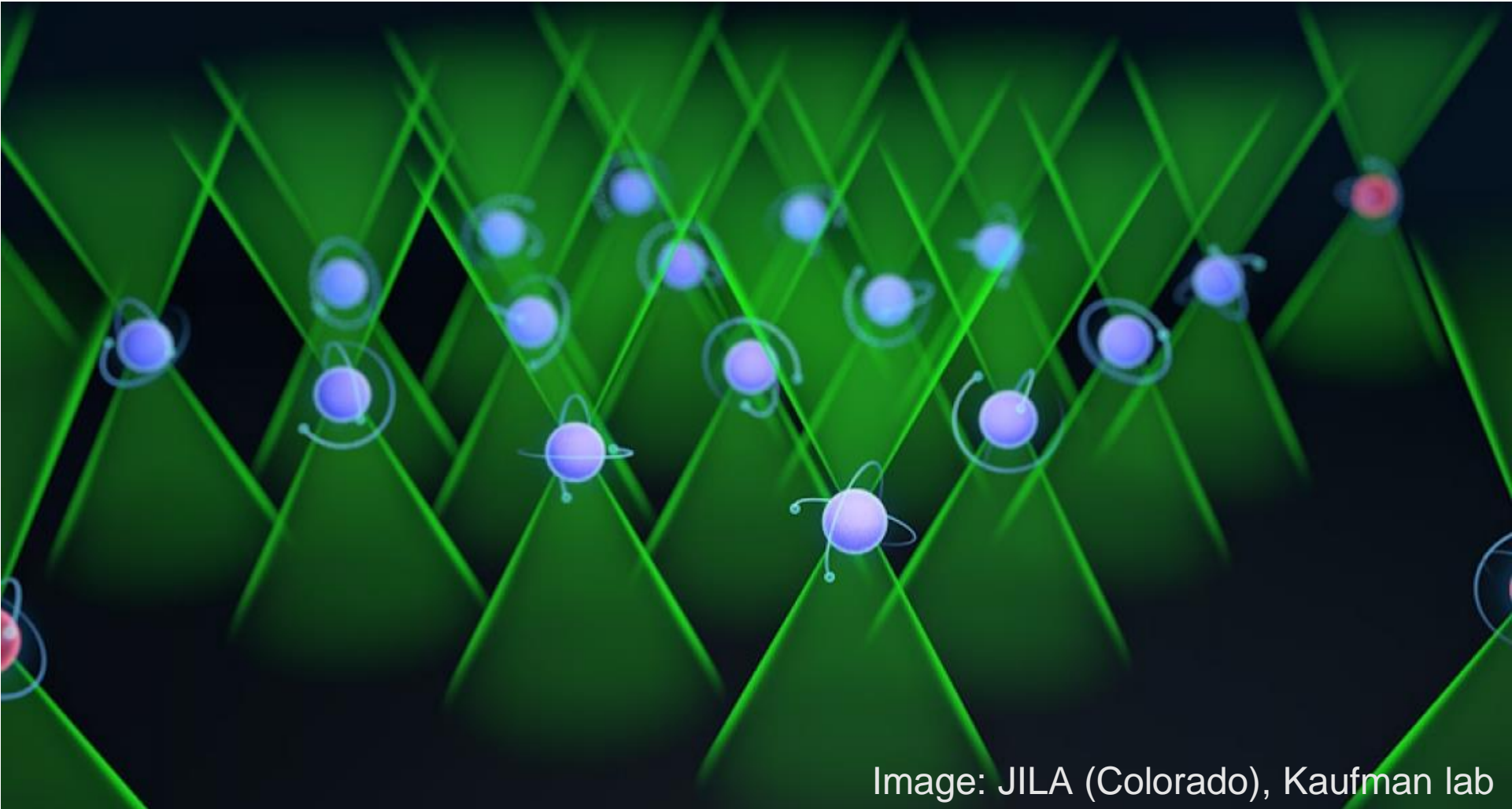

Image: JILA (Colorado), Kaufman lab

Quantum Computing & AION

Existing AION cold Sr system (80%)

+

New tweezer array (20%)

=

Quantum computer

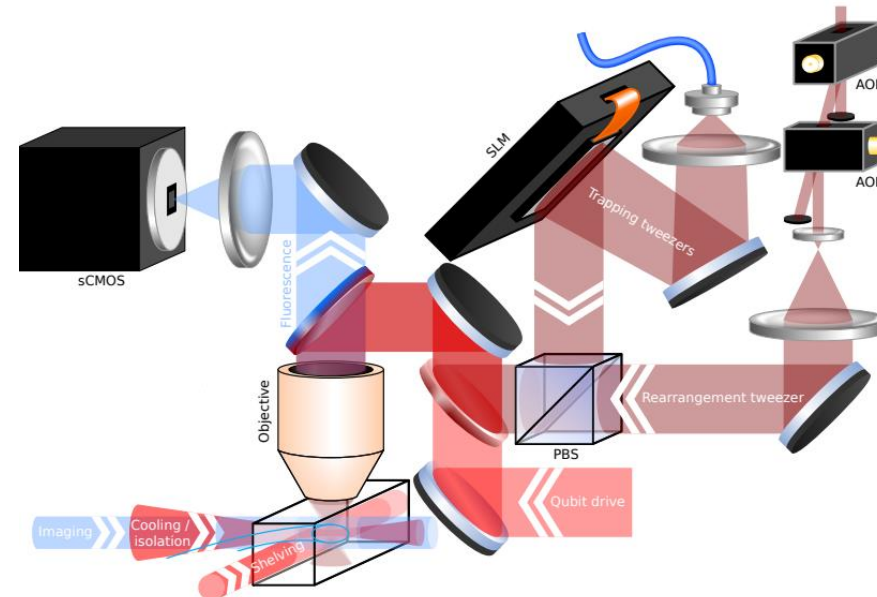
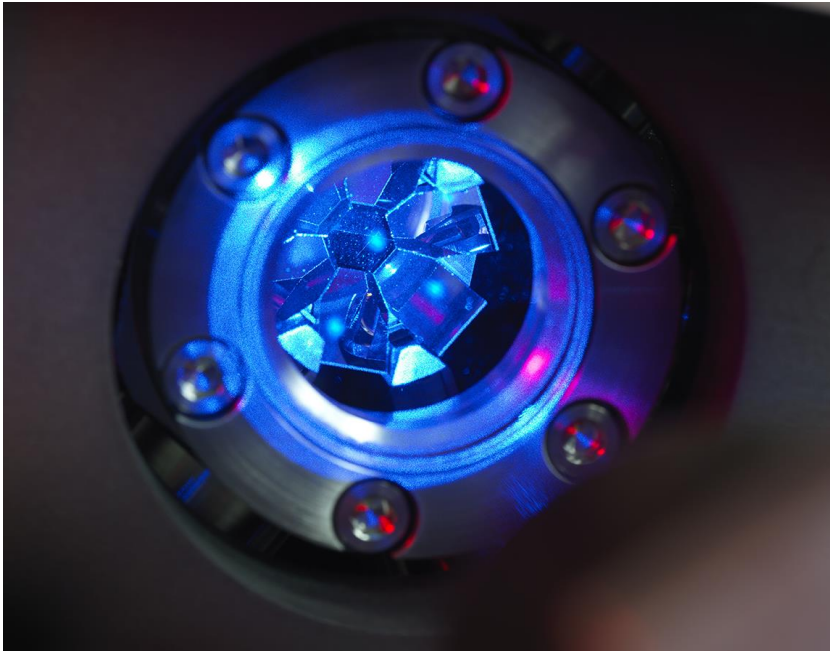

K. Barnes et al, <https://arxiv.org/abs/2108.04790> (2021)
– Atom Computing

Large Scale AI For Fundamental Physics

Quantum Computing & AION

1 qubit = 1 Sr atom

Quantum logic gates (the hard bit!): Rydbergs

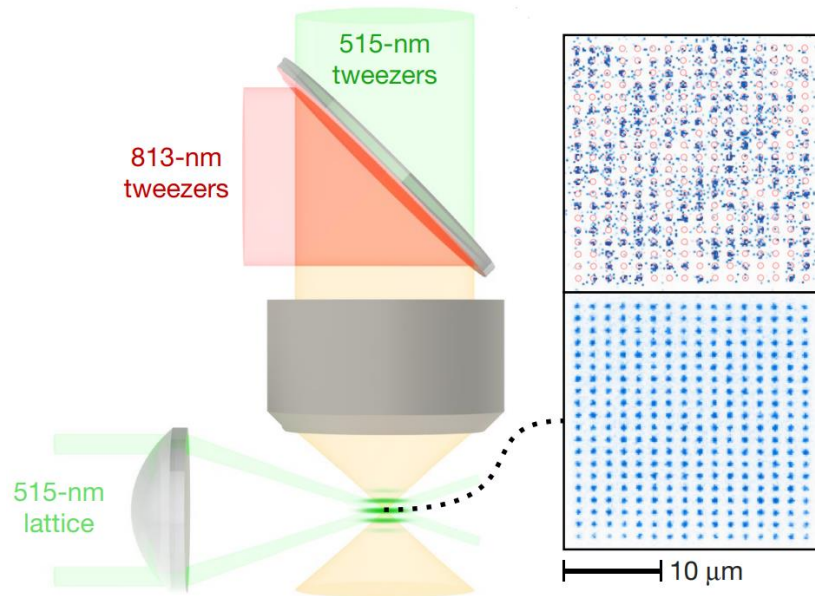

A. W. Young et al, Nature 588, 408-413 (2020)
– JILA Colorado, Kaufman lab

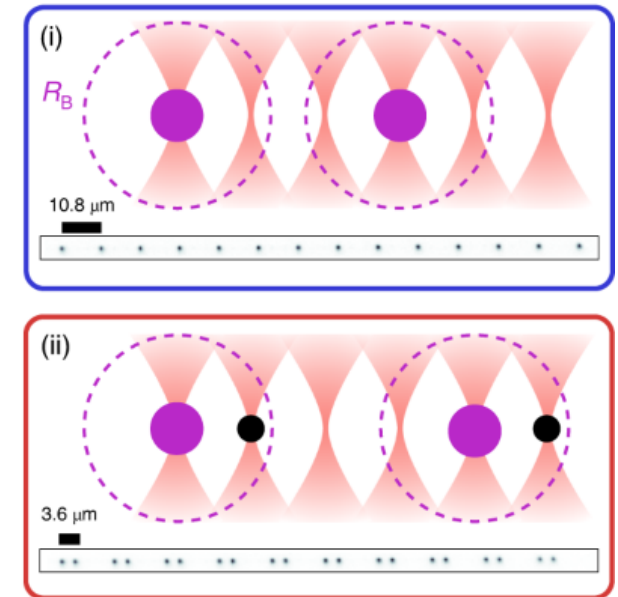
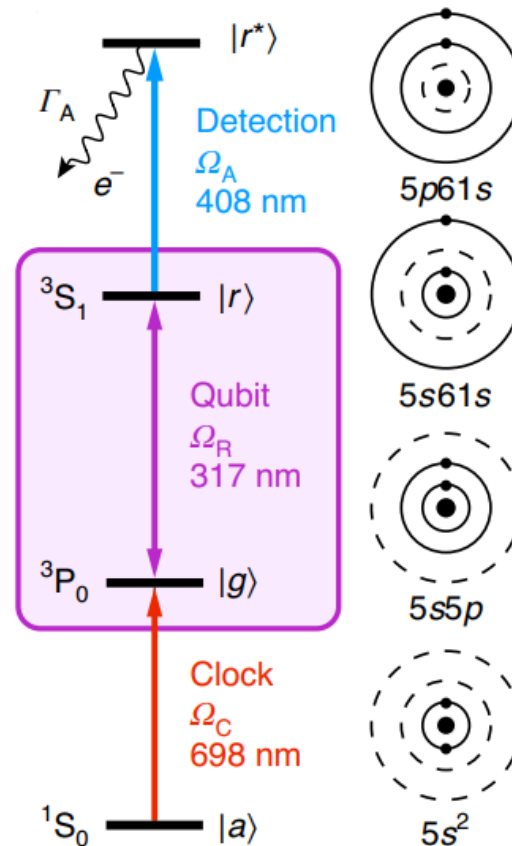

S. Madjarov et al. Nature Physics 16, 857-861 (2020)
– Caltec, Endres lab
99.9(2)% gate fidelity

Quantum Computing & AION

- Trapped-ion or superconducting qubits developed over ~ 20 years
- Tweezer array qubits started to emerge in the last ~ 10 years

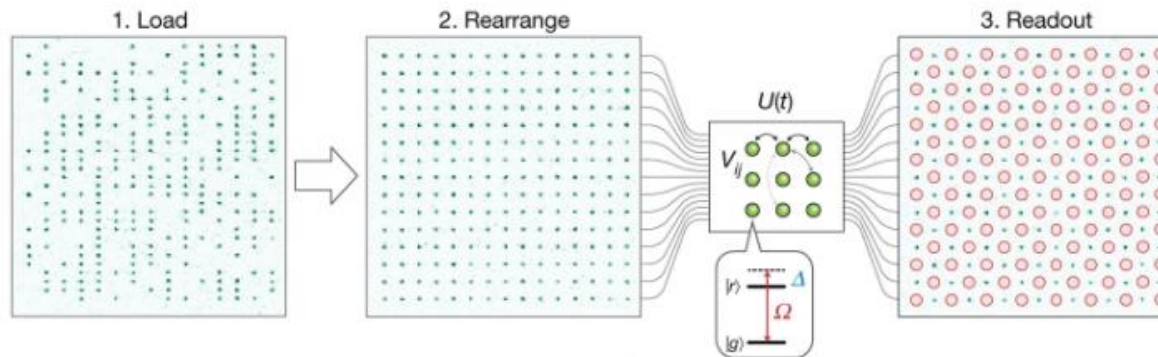

Why are we well placed to do this at Imperial?

- Atomic clocks → single qubit operations
- Squeezing → cavities to exchange atom vs photon qubits
- AION → robust, highly engineered Sr systems

Atoms in tweezers – some recent academic results:

S. Ebadi et al, Nature 595, 227-232 (2021) – Harvard, Lukin lab
 A. W. Young et al, Nature 588, 408-413 (2020) – JILA, Kaufman lab
 S. Madjarov et al. Nature Physics 16, 857-861 (2020) – Caltec, Endres lab
 P. Scholl et al, Nature 595, 233-238 (2021) – CNRS, Bronwaes lab

Startups in neutral atom computing

<https://atom-computing.com/> - \$60M funding round, 2022

<https://pasqal.io/about>

<https://coldquanta.com/core-technology/hilbert/>

<https://www.quera.com/>

<https://mobile.twitter.com/computingq>

Why Space?

One important argument in favour of Space (vs Earth) is interrogation time T of the atoms in free fall conditions.

To better understand this, it is useful to look at the short-term sensitivity to acceleration of an Atom Interferometer:

$$\delta g = \frac{\delta\phi}{nkT^2} \quad [\text{m/s}^2/\sqrt{\text{Hz}}]$$

where $\delta\phi$ is the atom-phase-resolution of the interferometer, n is the number of Large Momentum Transfer pulses, k is the effective wave-number of the atomic transition and T is the interrogation time between interferometer pulses.

On Earth, many interferometry experiments are limited by their free-fall interrogation times T , achieved through launching or dropping atom clouds at some limited distance above the floor. In space this limitation is removed, leading to potentially large improvements in performance.

Example:

Taking AION-10 goal as reference, we are planning to demonstrate that AION-10 can reach on earth with an interrogation time $T \sim 1\text{s}$ a δg of about 5.7×10^{-13} in 2024. In space, we estimate we could reach $T \sim 20\text{sec}$ and, thus, reach 3.9×10^{-14} (factor ~ 15 better).

Why Atom Interferometry in Space?

$$\Delta g = \frac{1}{kT^2\sqrt{N}}$$

**GRACE reference:
ONERA Superstar
Accelerometer: 10^{-10} m/s^2**

T=100ms N=10 ⁶	T=1s N=10 ⁶	T=10s N=10⁶	T=1s N=10 ⁶ 100 pulses	T=1s N=10 ⁸ 1000 pulses
6 10 ⁻⁹ m/s ²	6 10 ⁻¹¹ m/s ²	6 10⁻¹³ m/s²	6 10 ⁻¹³ m/s ²	3 10 ⁻¹⁴ m/s ²

Large $T \rightarrow$ large sensitivity

ROADMAP

Atomic Clock Progress

use for next-generation SI time standard worldwide?

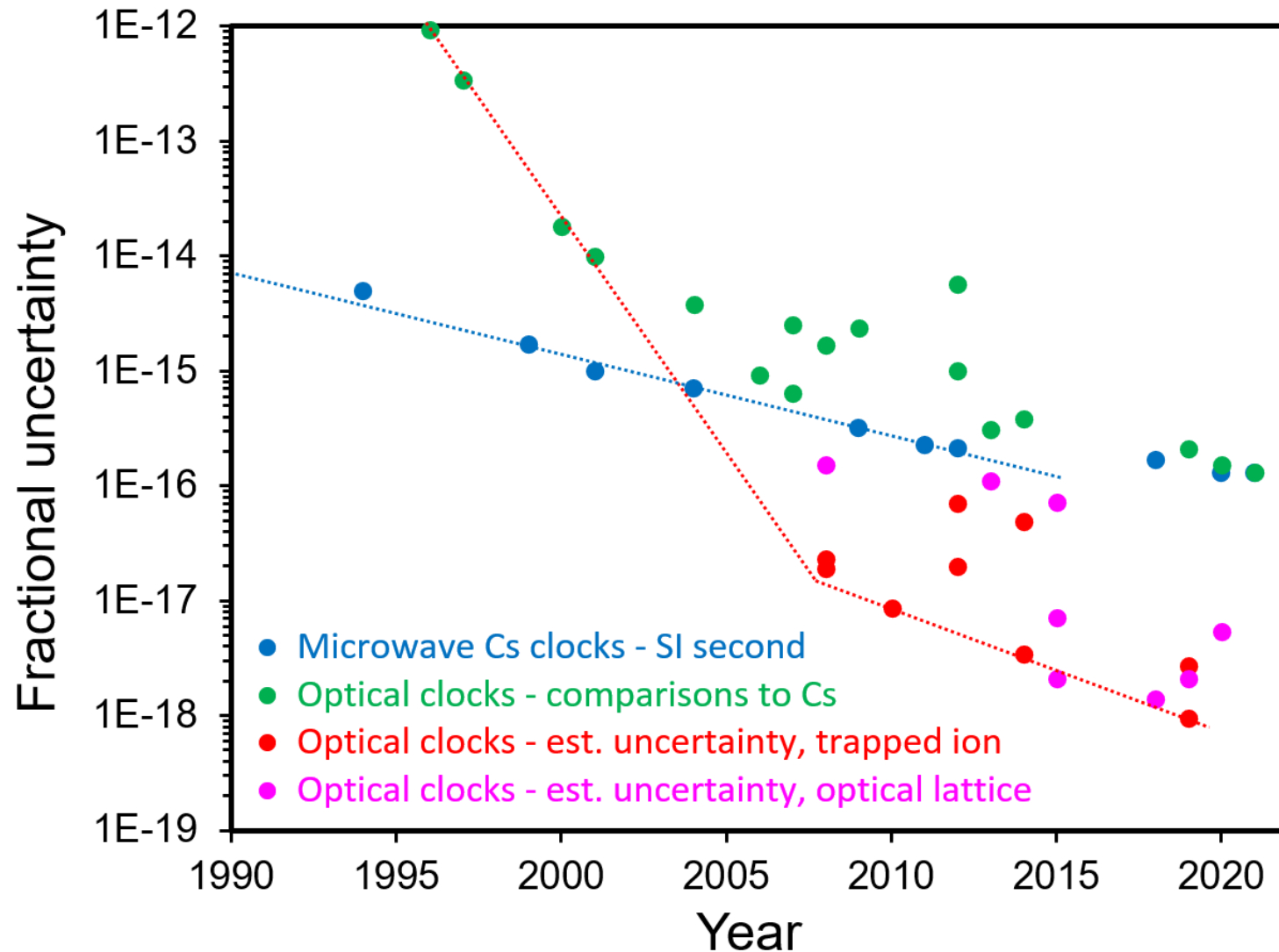

Atomic Clock Progress

ACES atomic clock mission: scheduled launch to ISS 2025

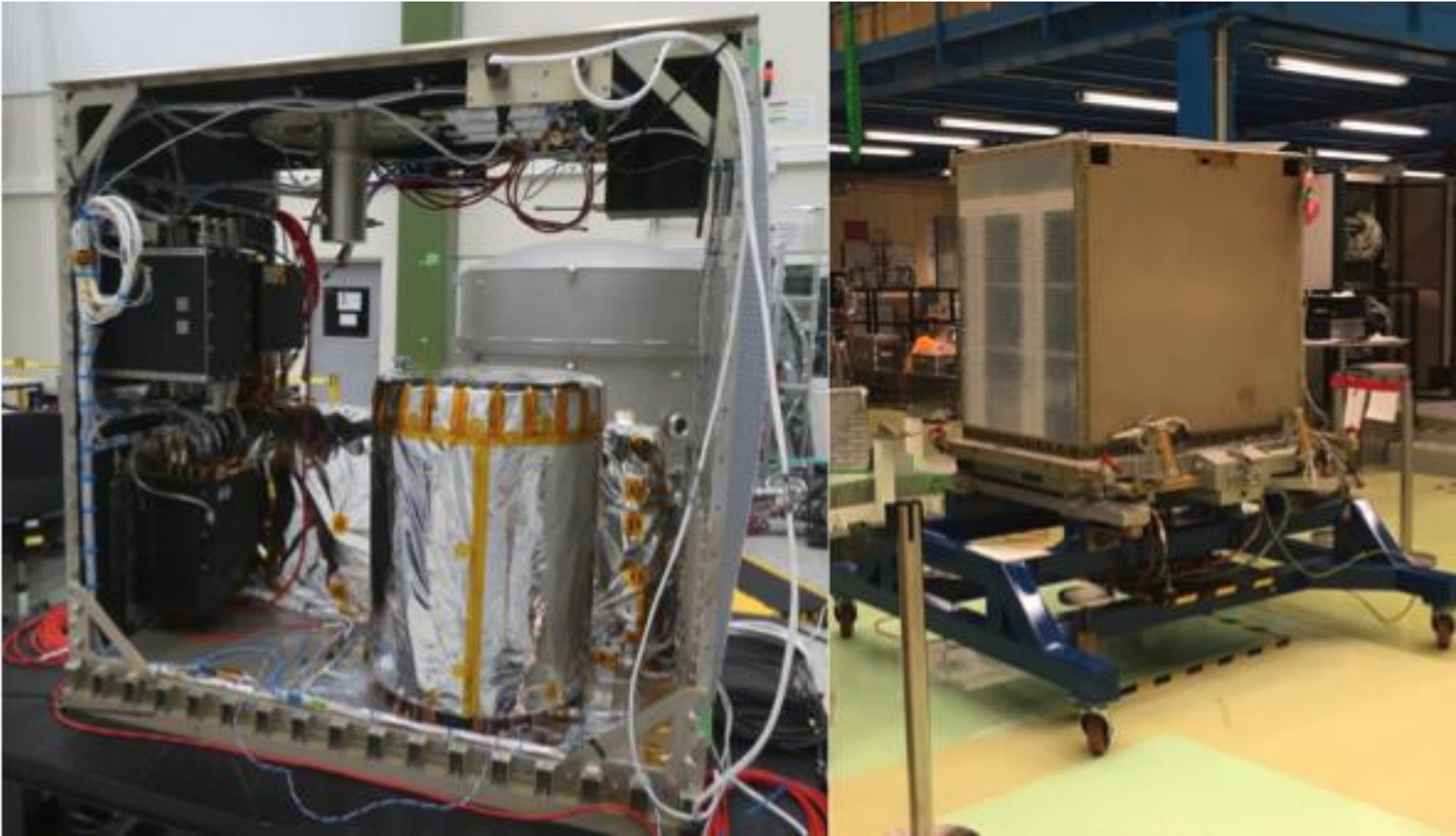

Large Scale AI For Fundamental Physics

Earth Observation Progress

Earth Observation: using classical electrostatic accelerometers & gradiometers

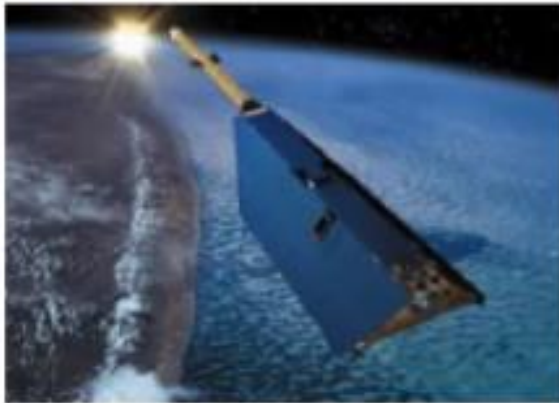

CHAMP : satellite tracking by GNSS + accelerometry

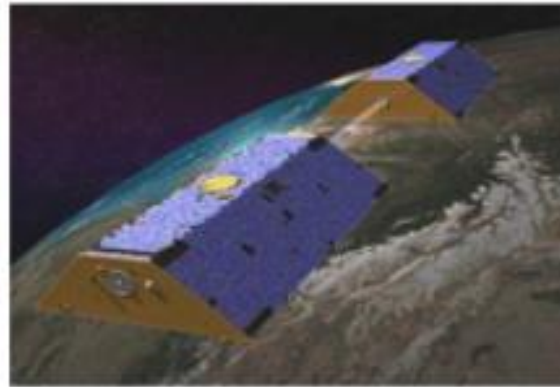

GRACE and GRACE-FO:
orbit determination + satellite-to-satellite tracking + accelerometry



GOCE: orbit determination + gradiometry

	CHAMP 2000 - 2010	GRACE/GRACE-FO 2002 - ongoing	NGGM Launch scheduled 2028	GOCE 2009 - 2013
Measurement type		Monitoring gravity field time variations		Static gravity field
EA accuracy	$\sim 10^{-10} \text{ m/s}^2$	$\sim 10^{-11} \text{ m/s}^2$	$\sim 10^{-11} \text{ m/s}^2$	$\sim 10^{-12} \text{ m/s}^2$
Geoid undulations	$\sim 10 \text{ cm}$ @350 km	$\sim 10 \text{ cm}$ @175 km	$\sim 1 \text{ mm}$ @ 500 km every 3 days $\sim 1 \text{ mm}$ @ 150 km every 10 days	$\sim 1 \text{ cm}$ @100 km
Gravity anomalies	$\sim 0.02 \text{ mGal}$ @1000 km	$\sim 1 \text{ mGal}$ @175 km		$\sim 1 \text{ mGal}$ @100 km

Earth Observation Progress

Frequency Sensitivity advantage of cold atom gravity gradiometers at low frequency, no drift

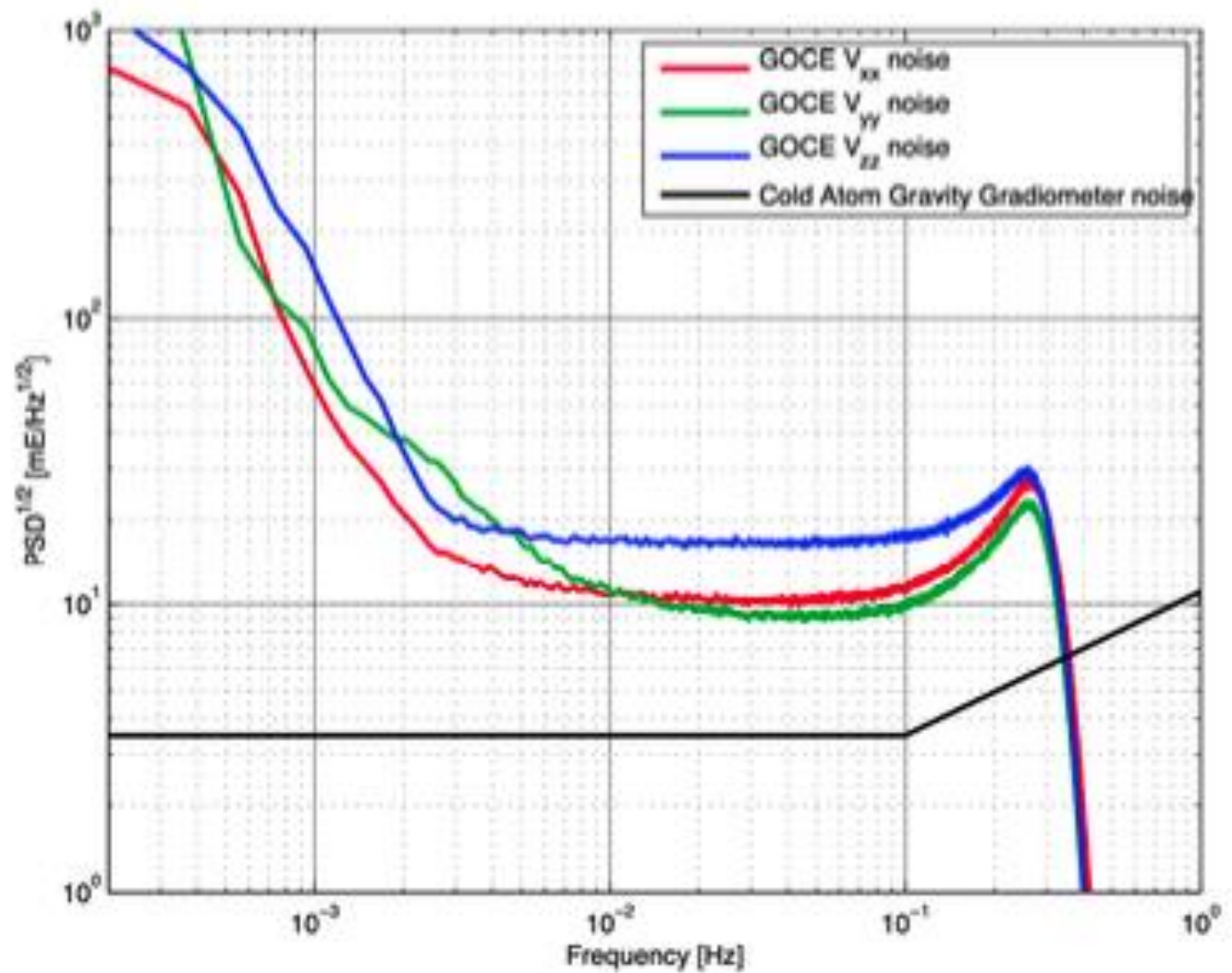

Large Scale AI For Fundamental Physics

Earth Observation Progress

Sensitivity to Water Height
crucial for monitoring climate change

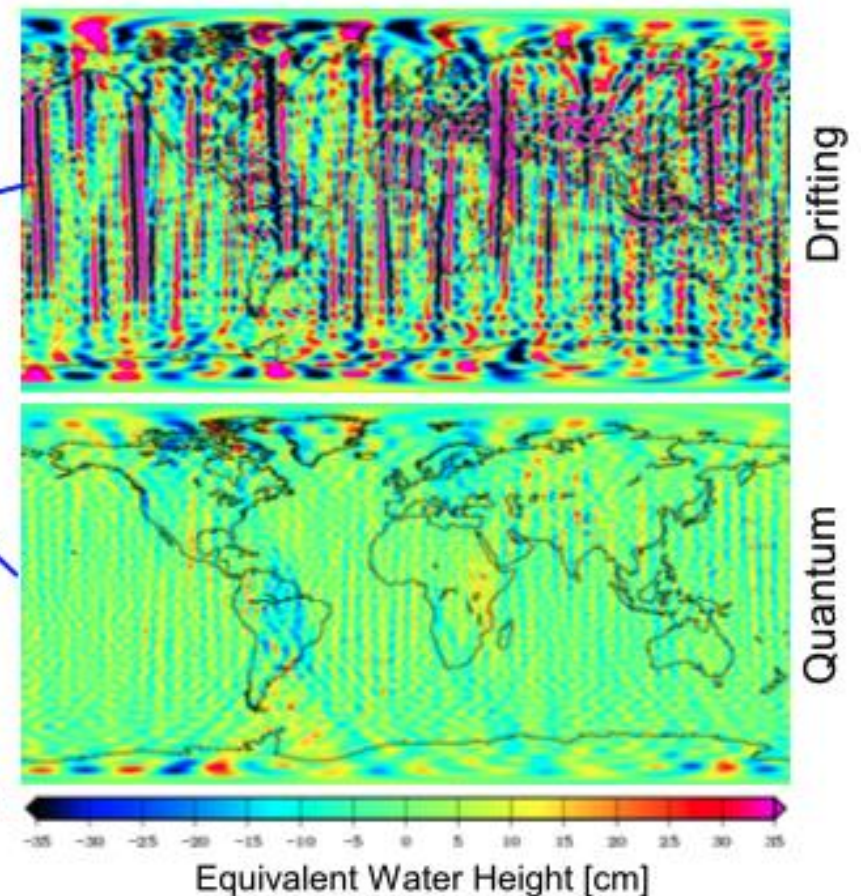
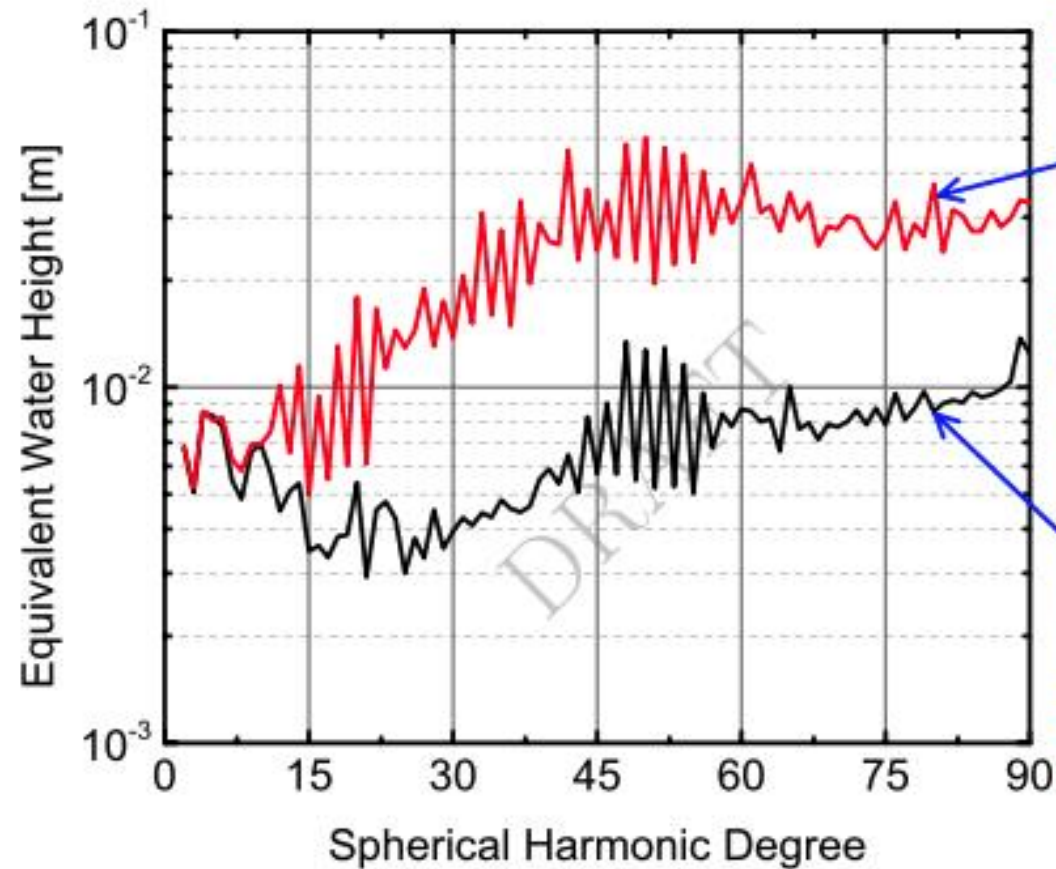

Large Scale AI For Fundamental Physics

Vision for 2045+

Probe formation of SMBHs: Synergies with other GW experiments (LIGO, LISA), test GR

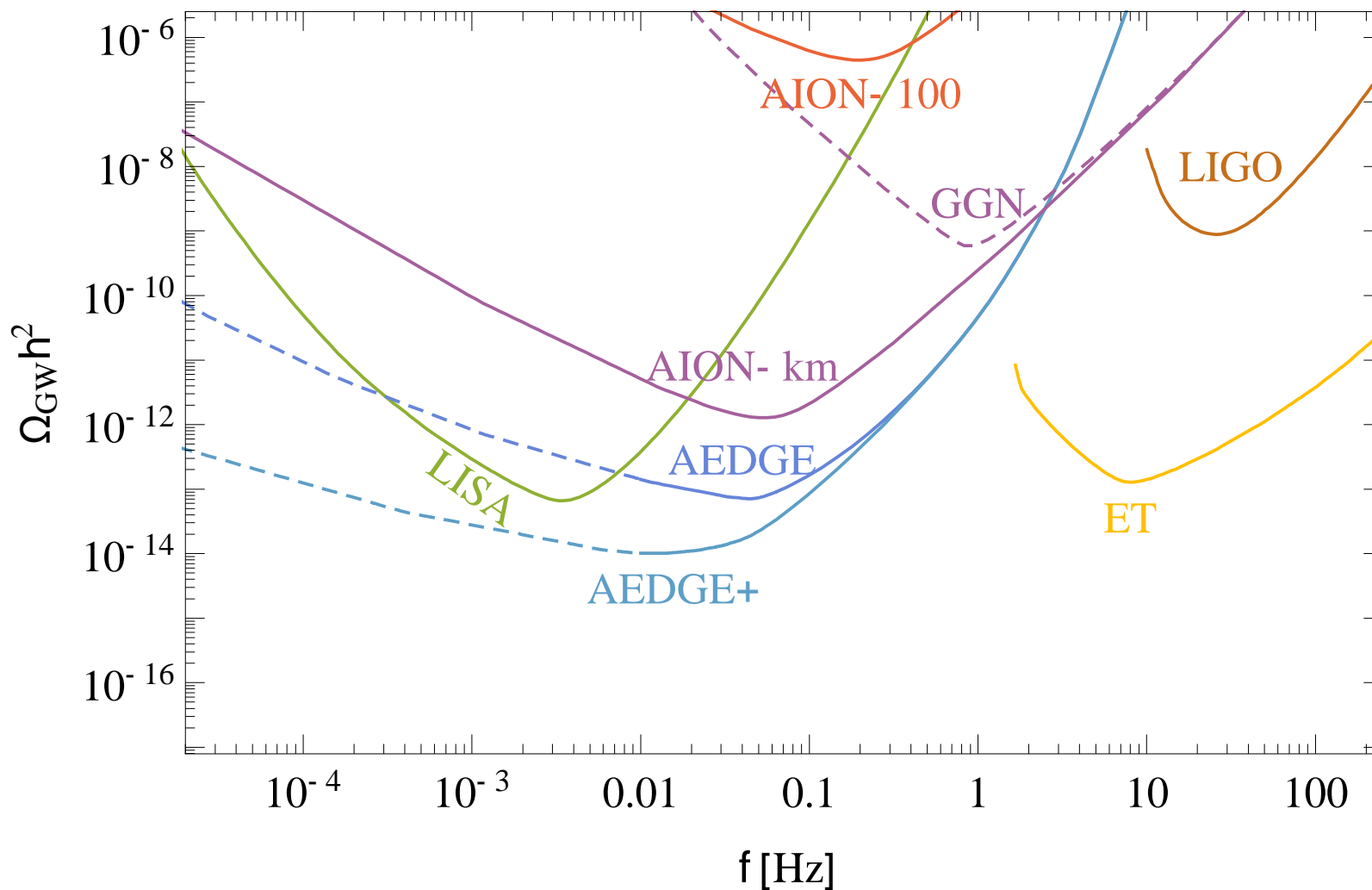

Translate Stain sensitivity into the dimensionless energy density of a GW

Large Scale AI For Fundamental Physics

Vision for 2045+

Probe formation of SMBHs: Synergies with other GW experiments (LIGO, LISA), test GR

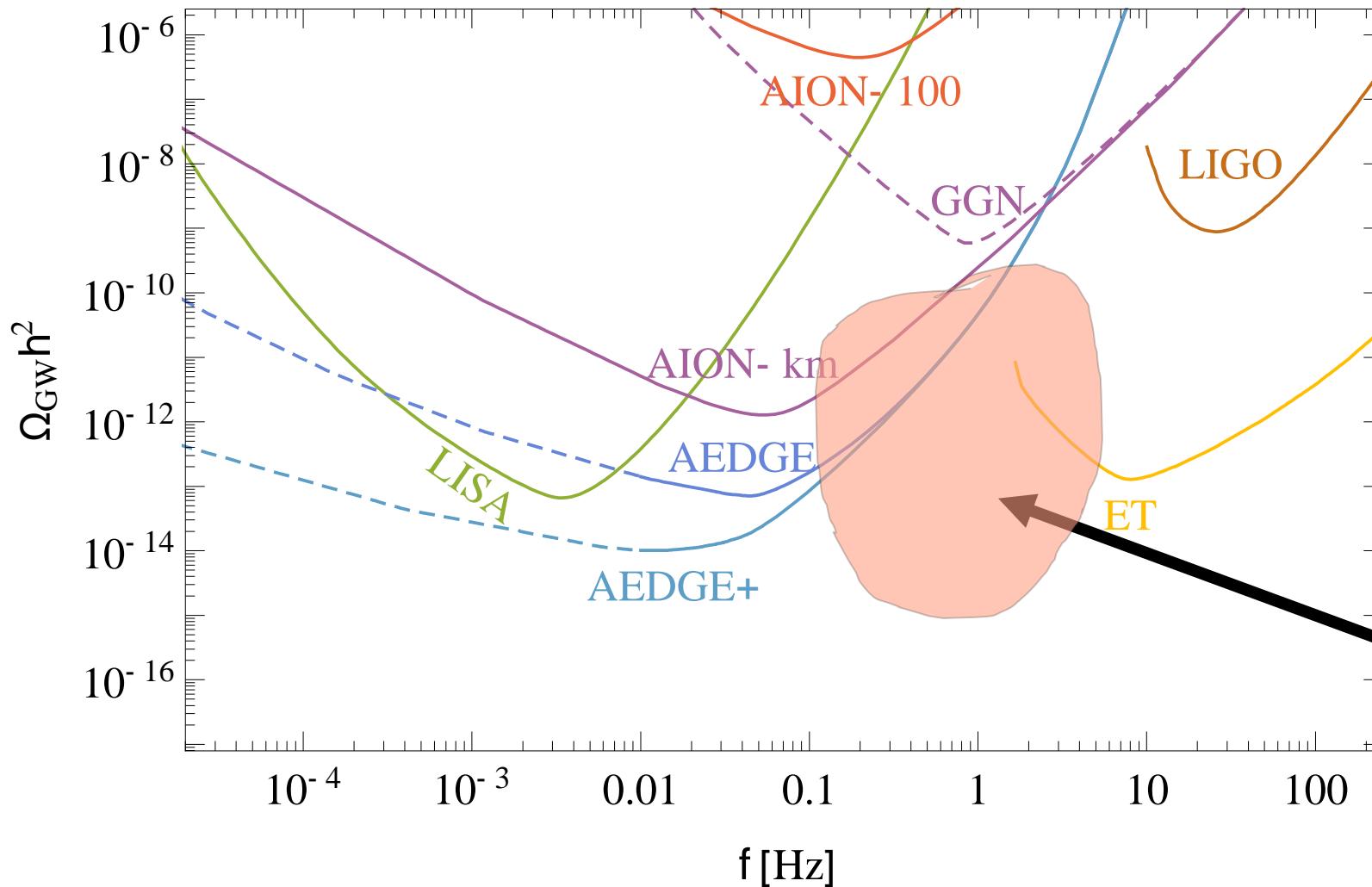

Translate Stain sensitivity into the dimensionless energy density of a GW

Still a “gap” around 1Hz
Need to find a solution to fill it

Large Scale AI For Fundamental Physics

The GW Experimental Landscape: 2030ish

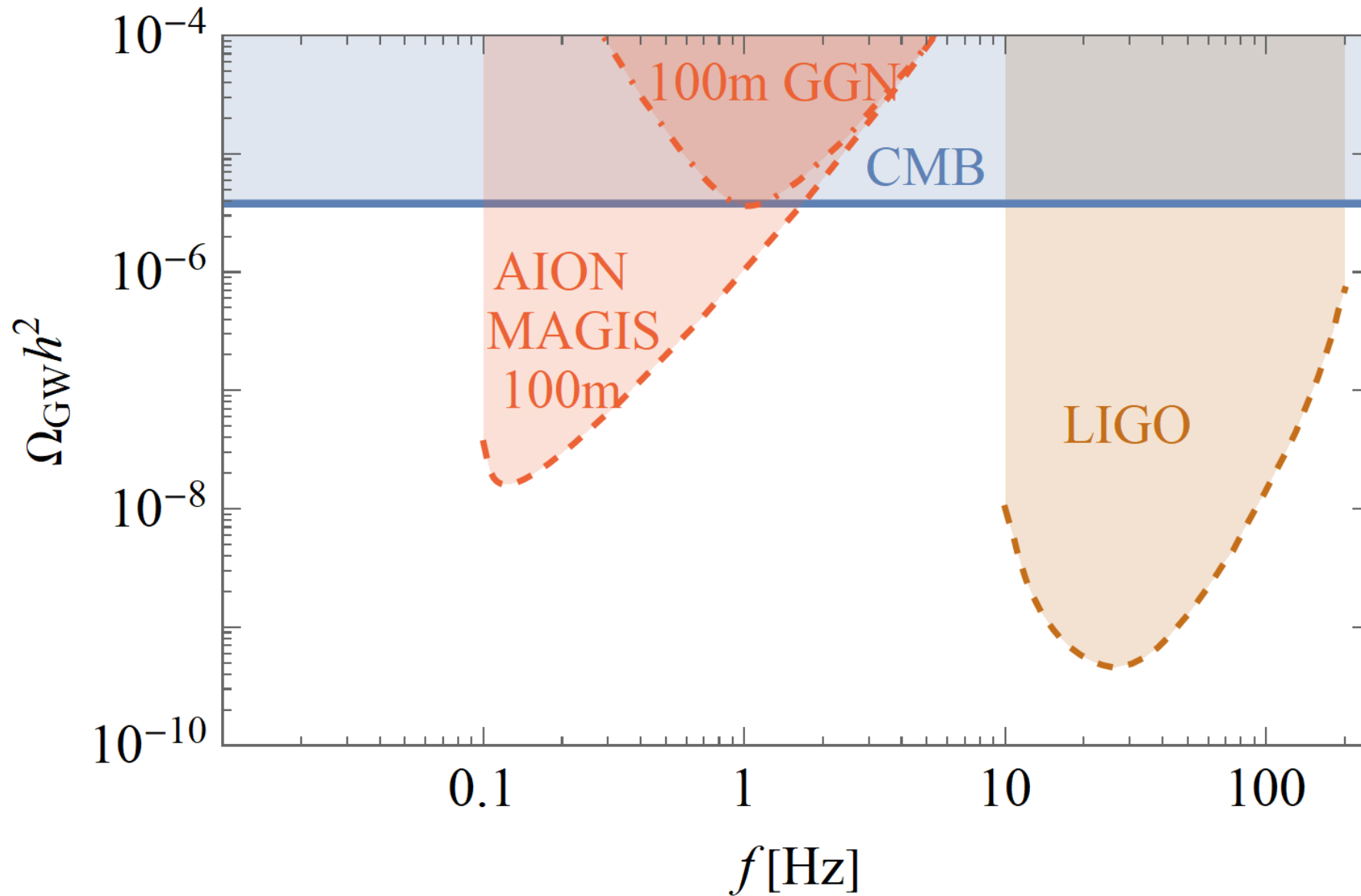

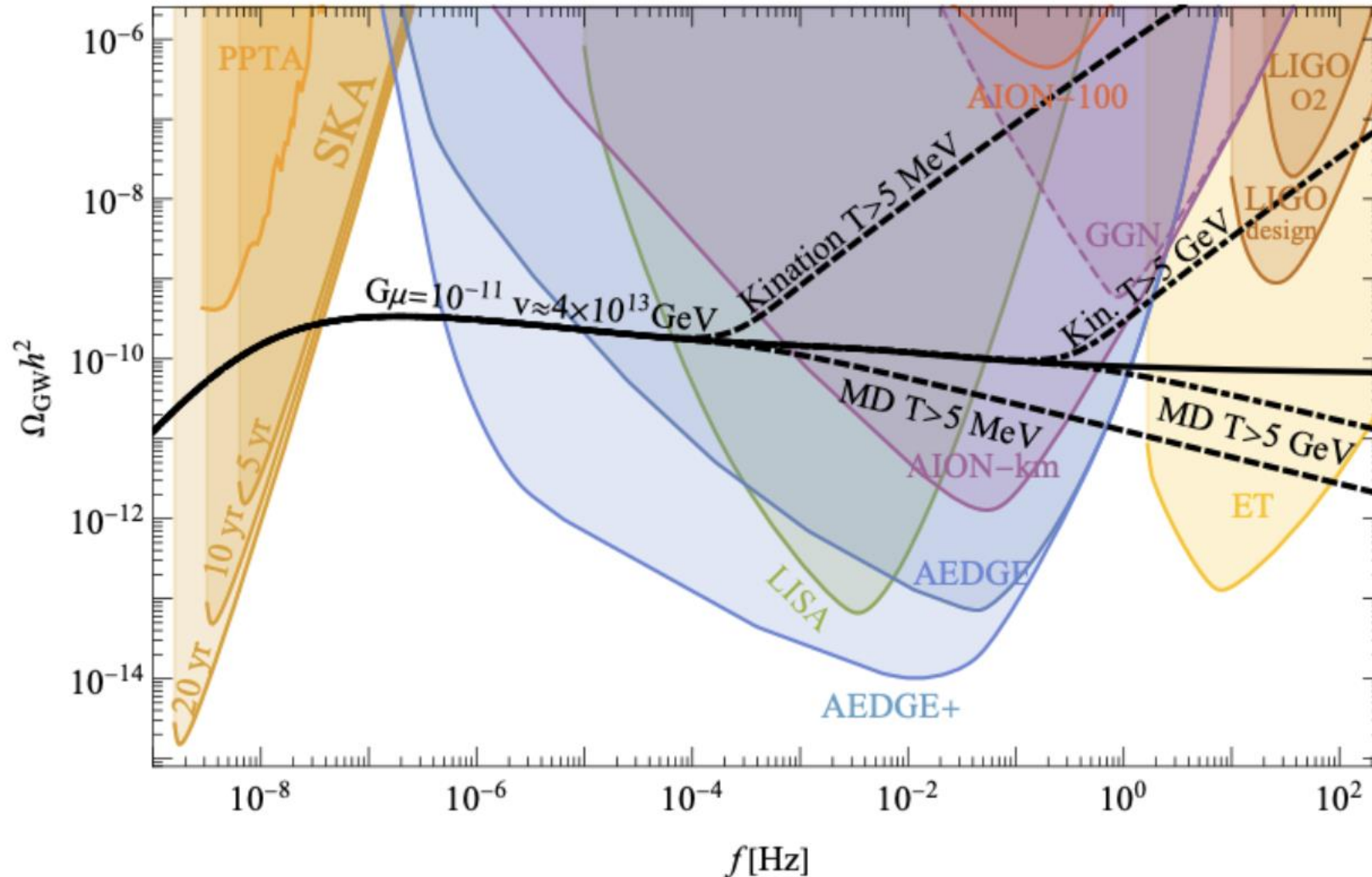

Comparison of the Ω sensitivities to PI spectra of AION-100, AION-km, AEDGE and AEDGE+, LIGO, ET, Pulsar Timing Arrays (PTAs) and SKA.

Sensitivities of cosmic string measurements to modifications of the cosmological expansion rate. Kination or matter dominance (MD) at temperatures $T > 5 \text{ MeV}$ or 5 GeV .

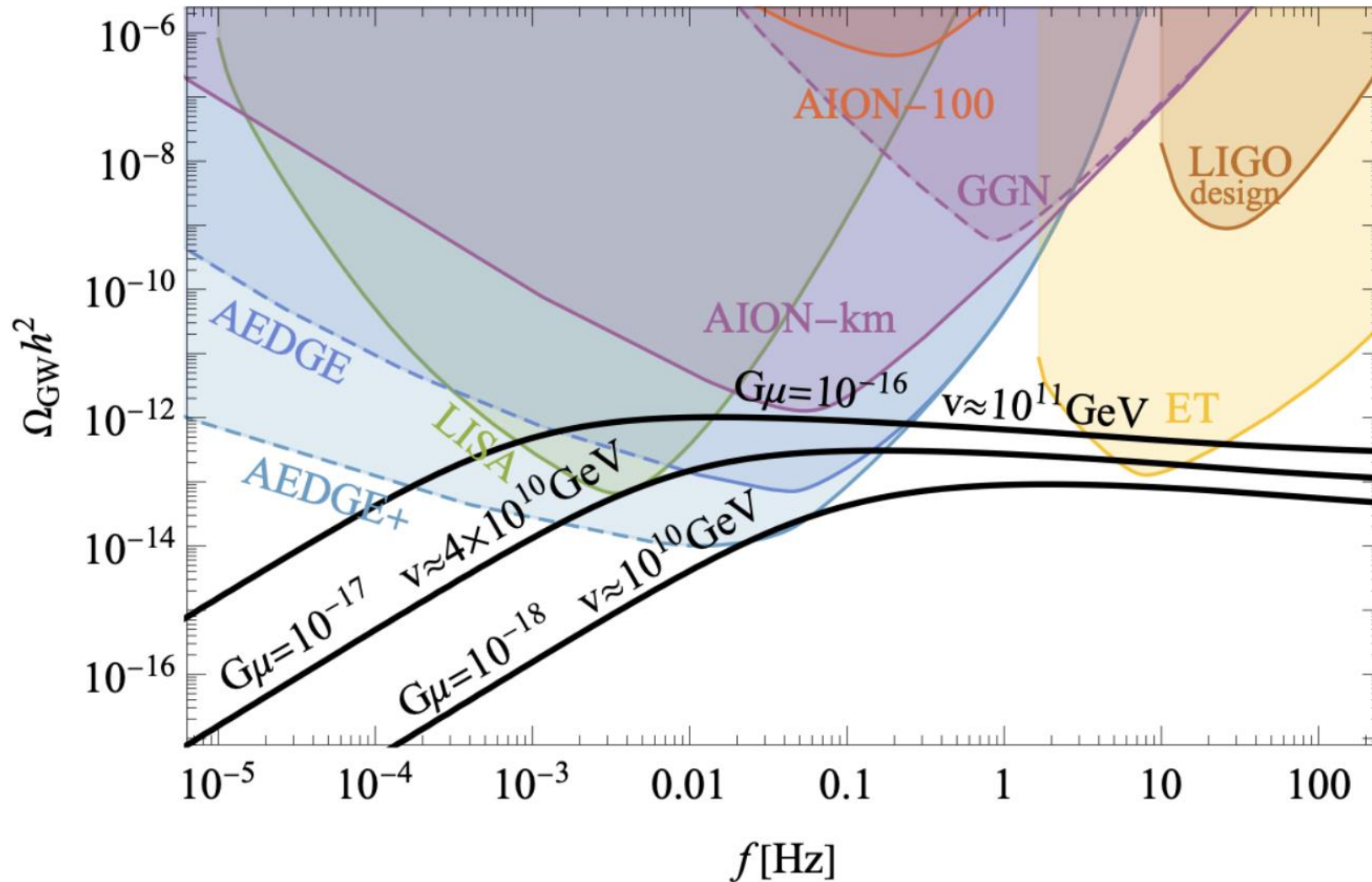

Different experiments sensitive to different values of cosmic string tension

Sensitivities to the cosmic strings with tension $G\mu$ of AION-100 and -km, AEDGE and AEDGE+, LIGO, ET and LISA.

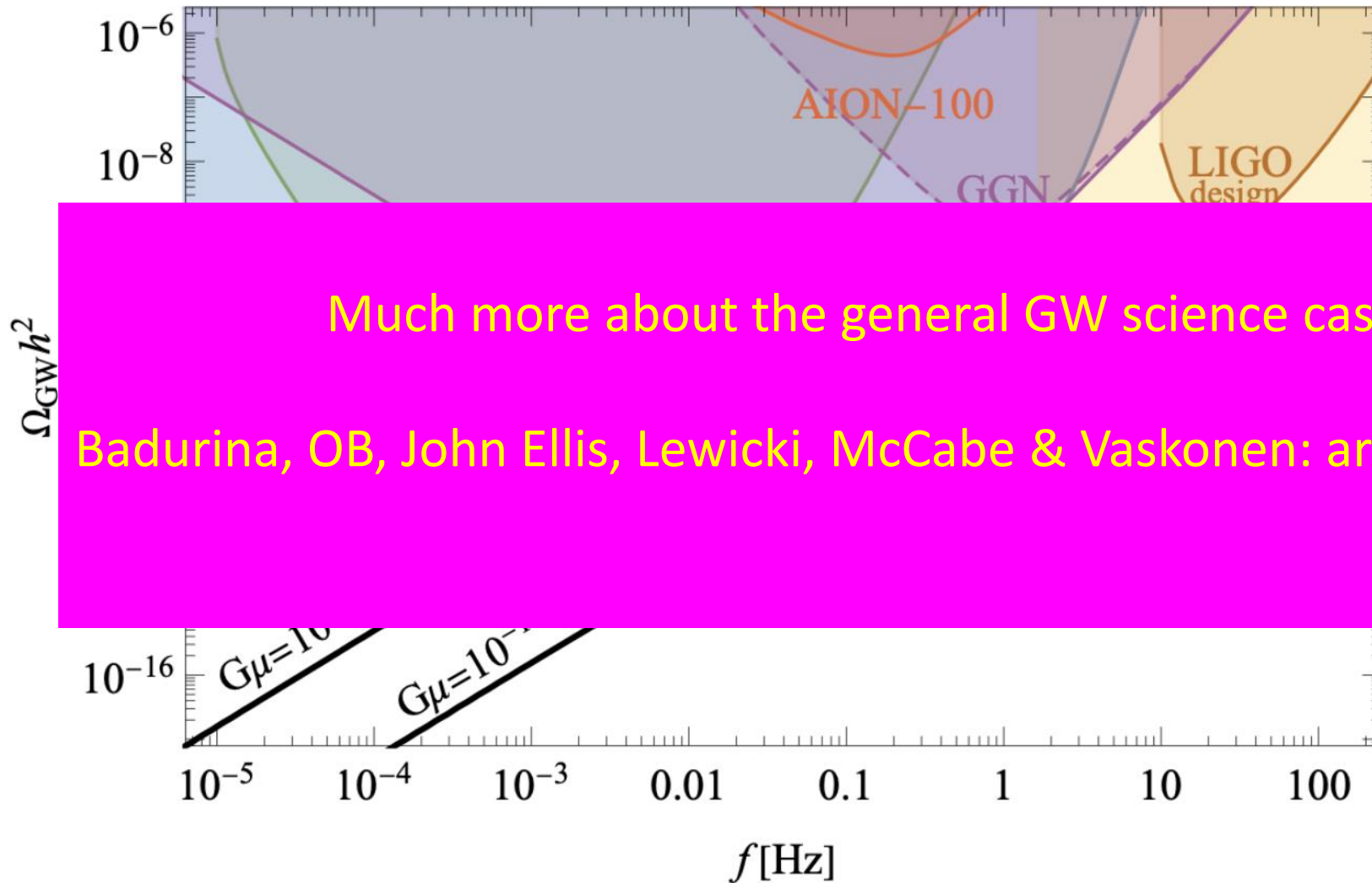

Different experiments sensitive to different frequencies of cosmic strings

Much more about the general GW science case in:

Badurina, OB, John Ellis, Lewicki, McCabe & Vaskonen: arXiv:2108.02468

Sensitivities to the cosmic strings with tension $G\mu$ of AION-100 and -km, AEDGE and AEDGE+, LIGO, ET and LISA.

Earth Observation Progress

Requirements & Objectives

Threshold requirements

Spatial resolution	Equivalent water height		Geoid	
	Monthly field	Long-term trend	Monthly field	Long-term trend
400 km	5 mm	0.5 mm/yr	50 μm	5 $\mu\text{m}/\text{yr}$
200 km	10 cm	1 cm/yr	0.5 mm	0.05 mm/yr
150 km	50 cm	5 cm/yr	1 mm	0.1 mm/yr
100 km	5 m	0.5 m/yr	10 mm	1 mm/yr

Target objectives

Spatial resolution	Equivalent water height		Geoid	
	Monthly field	Long-term trend	Monthly field	Long-term trend
400 km	0.5 mm	0.05 mm/yr	5 μm	0.5 $\mu\text{m}/\text{yr}$
200 km	1 cm	0.1 cm/yr	0.05 mm	5 $\mu\text{m}/\text{yr}$
150 km	5 cm	0.5 cm/yr	0.1 mm	0.01 mm/yr
100 km	0.5 m	0.05 m/yr	1 mm	0.1 mm/yr

Fundamental Physics Part

Tests of Weak Equivalence Principle (Universality of Free Fall)

Class	Elements	η	Year [ref]	Comments
Classical	Be - Ti	2×10^{-13}	2008 [200]	Torsion balance
	Pt - Ti	1×10^{-14}	2017 [179]	MICROSCOPE first results
	Pt - Ti	(10^{-15})	2019+	MICROSCOPE full data
Hybrid	^{133}Cs - CC	7×10^{-9}	2001 [204]	Atom Interferometry
	^{87}Rb - CC	7×10^{-9}	2010 [205]	and macroscopic corner cube
Quantum	^{39}K - ^{87}Rb	5×10^{-7}	2014 [206]	different elements
	^{87}Sr - ^{88}Sr	2×10^{-7}	2014 [207]	same element, fermion vs. boson
	^{85}Rb - ^{87}Rb	3×10^{-8}	2015 [208]	same element, different isotopes
	^{85}Rb - ^{87}Rb	3.8×10^{-12}	2020 [209]	≥ 10 m towers
	^{85}Rb - ^{87}Rb	(10^{-13})	2020+ [210]	
	^{170}Yb - ^{87}Rb	(10^{-13})	2020+ [211]	
Antimatter	^{41}K - ^{87}Rb	10^{-17}	2035+	STE-QUEST-like mission
	$\bar{\text{H}}$ - H	(10^{-2})	2020+ [212]	under construction at CERN