

JUNO Neutrino Experiment

Yifang Wang

Institute of High Energy Physics

CERN, March 20, 2024



12 years anniversary, What a coincidence !



Observation of Electron Anti-neutrino Disappearance at Daya Bay

Yifang Wang

Institute of High Energy Physics

CERN, March 20, 2012

Neutrino Oscillation



◆ **Mixing matrix(PMNS):**

$$\begin{pmatrix} \nu_e \\ \nu_\mu \\ \nu_\tau \end{pmatrix} = \begin{pmatrix} V_{e1} & V_{e2} & V_{e3} \\ V_{\mu1} & V_{\mu2} & V_{\mu3} \\ V_{\tau1} & V_{\tau2} & V_{\tau3} \end{pmatrix} \begin{pmatrix} \nu_1 \\ \nu_2 \\ \nu_3 \end{pmatrix}$$

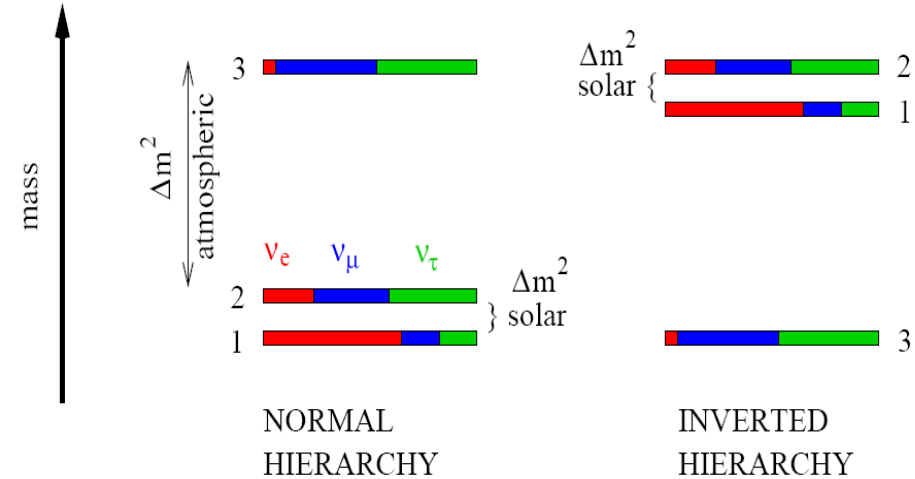

$$V = \begin{matrix} \text{Atmospheric} & \text{reactor \& CP phase} & \text{Solar} & \text{Majorana phase} \\ \begin{pmatrix} 1 & 0 & 0 \\ 0 & c_{23} & s_{23} \\ 0 & -s_{23} & c_{23} \end{pmatrix} & \begin{pmatrix} c_{13} & 0 & s_{13} \\ 0 & e^{-i\delta} & 0 \\ -s_{13} & 0 & c_{13} \end{pmatrix} & \begin{pmatrix} c_{12} & s_{12} & 0 \\ -s_{12} & c_{12} & 0 \\ 0 & 0 & 1 \end{pmatrix} & \begin{pmatrix} e^{i\rho} & 0 & 0 \\ 0 & e^{i\sigma} & 0 \\ 0 & 0 & 1 \end{pmatrix} \end{matrix}$$

- **Known parameters:** $\theta_{23}, \theta_{12}, \theta_{13}, |\Delta m^2_{32}|, \Delta m^2_{21}$
- **Unknown parameters:** sign of Δm^2_{32} , CP phase δ

1998 Atm. ν osc. $\theta_{23}, |\Delta m^2_{32}|$
 2002 Solar ν osc. $\theta_{12}, \Delta m^2_{21}$
 2012 reactor ν osc. θ_{13}

Idea of the JUNO Experiment



- Next step of the Daya Bay Exp.: continue using reactor neutrinos and liquid scintillator
- To determine the mass ordering (sign of Δm_{32}^2) independent of the CP phase δ
- Equal baseline to two reactor power plants: Yangjiang and Taishan

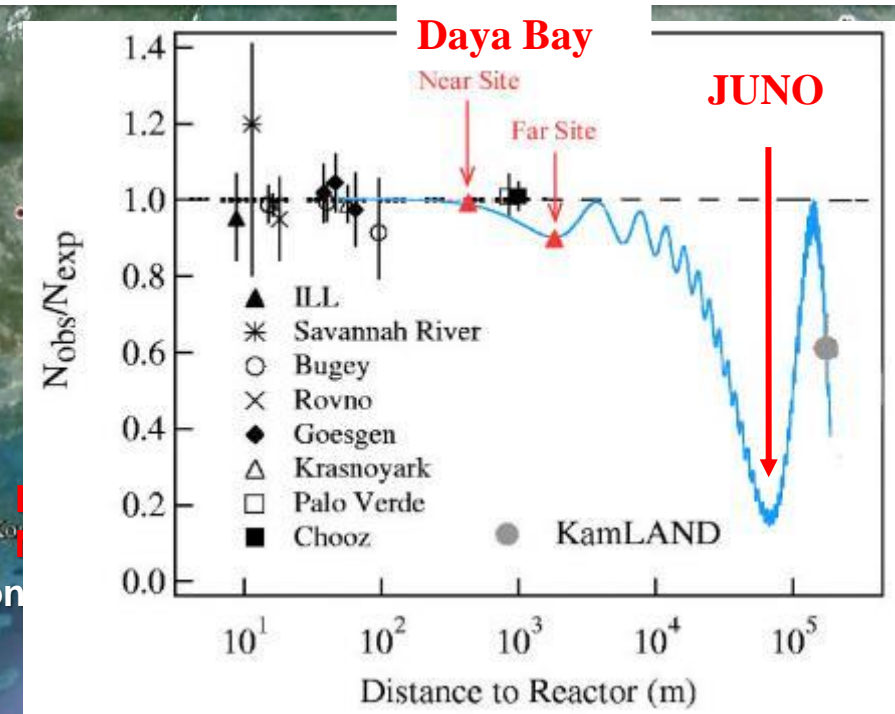
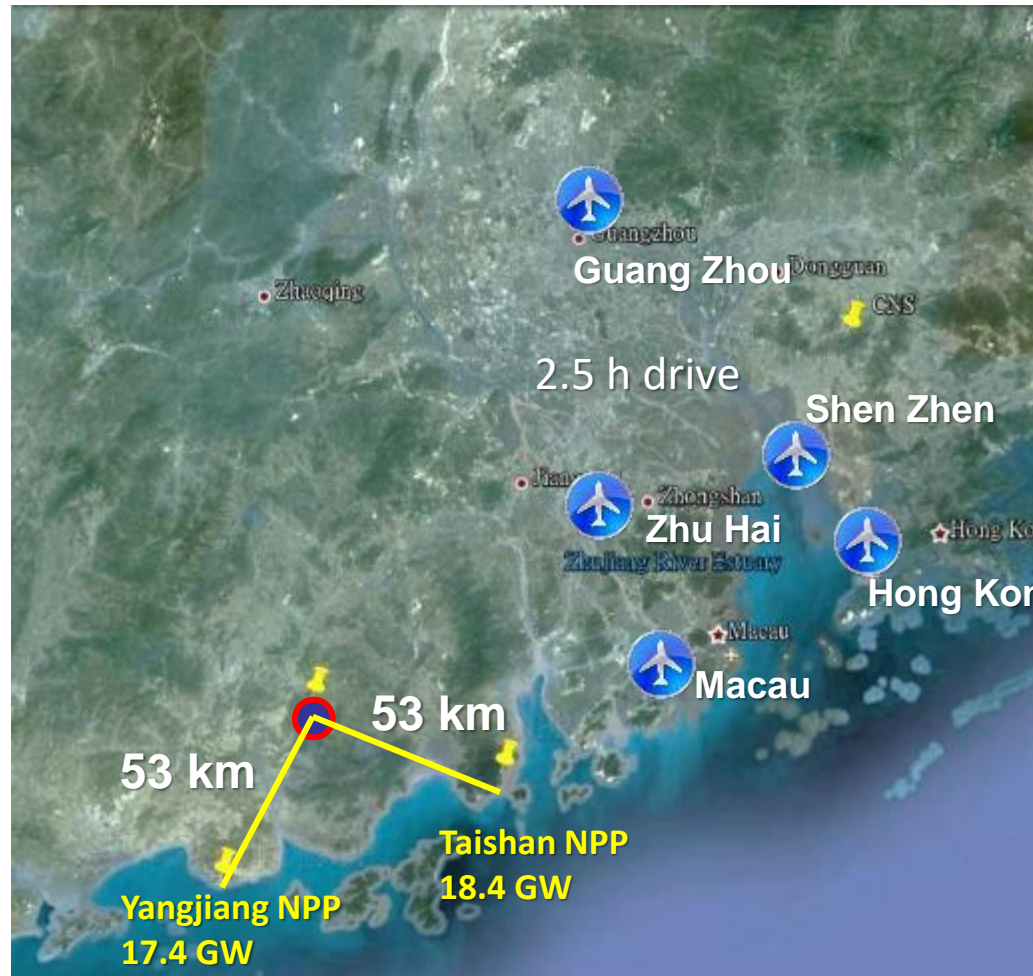

Talk by Y.F. Wang at ICFA seminar 2008, Neutel 2011;
Paper by L. Zhan, Y.F. Wang, J. Cao, L.J. Wen,
PRD78:111103,2008; PRD79:073007,2009

Mass Ordering by Reactor Neutrinos

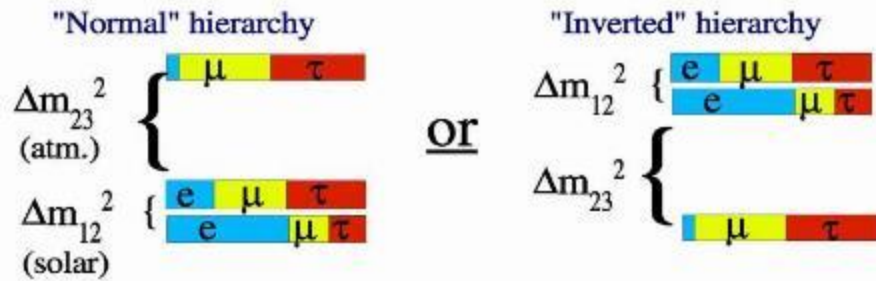

$$\Delta m_{31}^2 = \Delta m_{32}^2 + \Delta m_{21}^2$$

NH : $|\Delta m_{31}^2| = |\Delta m_{32}^2| + |\Delta m_{21}^2|$
 IH : $|\Delta m_{31}^2| = |\Delta m_{32}^2| - |\Delta m_{21}^2|$

$$\frac{\Delta m_{21}^2}{|\Delta m_{32}^2|} \sim 3\%$$

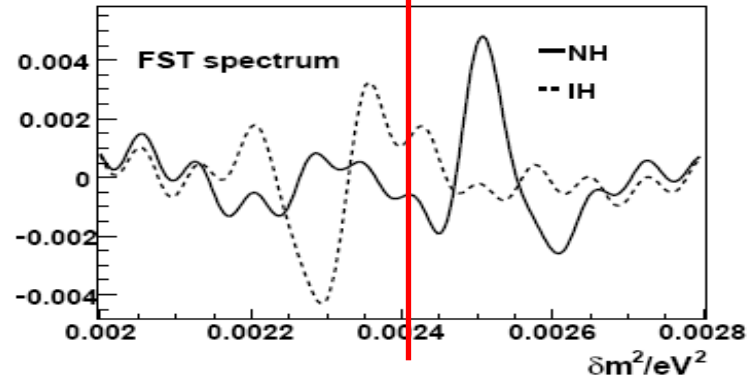
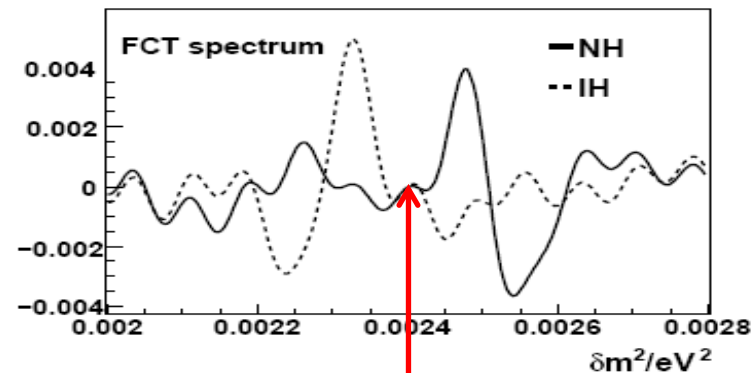
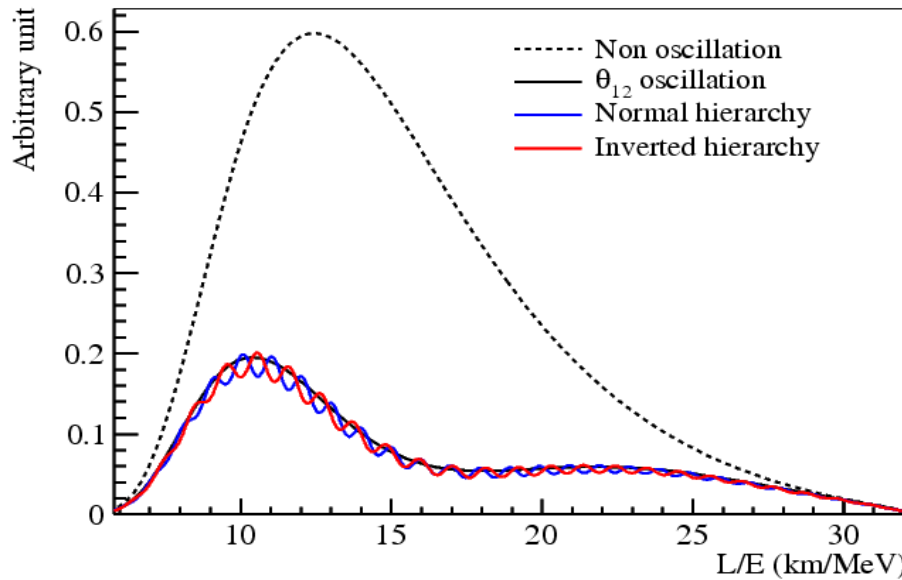

$$P_{ee}(L/E) = 1 - P_{21} - P_{31} - P_{32}$$

$$P_{21} = \cos^4(\theta_{13}) \sin^2(2\theta_{12}) \sin^2(\Delta_{21})$$

$$P_{31} = \cos^2(\theta_{12}) \sin^2(2\theta_{13}) \sin^2(\Delta_{31})$$

$$P_{32} = \sin^2(\theta_{12}) \sin^2(2\theta_{13}) \sin^2(\Delta_{32})$$

S. Petcov and Piai, Phys. Lett. B 553, 94-106(2002)
 J. Learned et al., PRD 78(2008)071302
 L. Zhan, YFW et al., PRD 78(2008)111103

Optimum Baseline and Site Selection

- Optimum sensitivity at the oscillation maximum of θ_{12}
- Multiple baseline reactors may wash out the oscillation structure
 - Baseline difference should be < 500 m

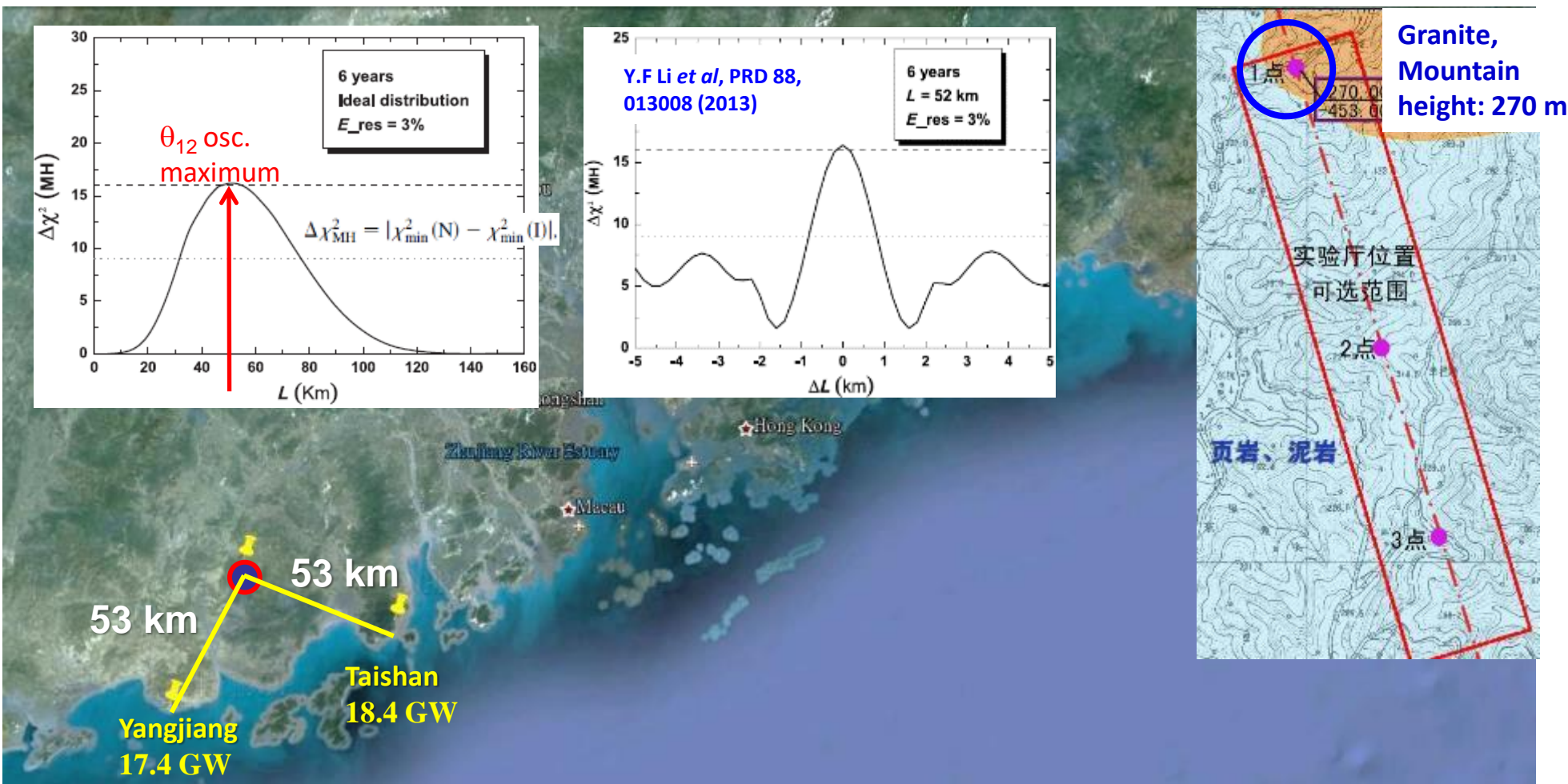

First Experimental Proposal



- Key parameters:
 - Detector size: 20kt
 - Energy resolution: $3\%/\sqrt{E}$
 - Thermal power: 36 GW
 - Baseline: ~ 58 km

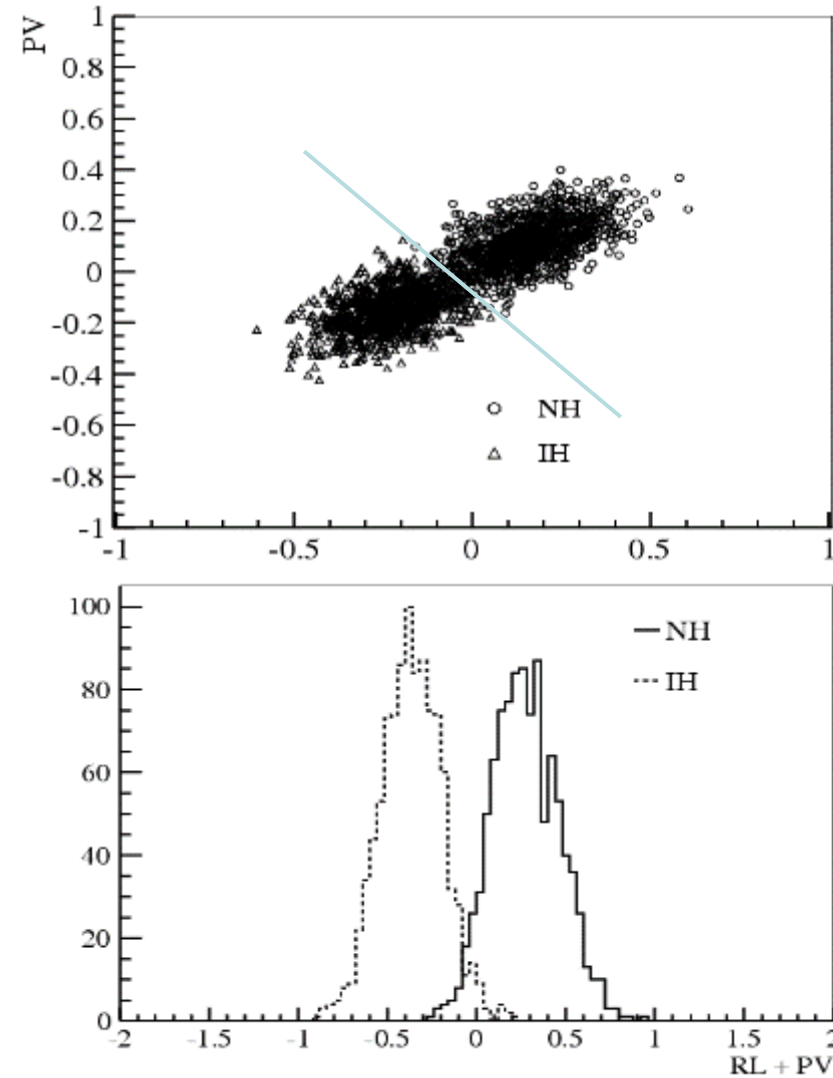
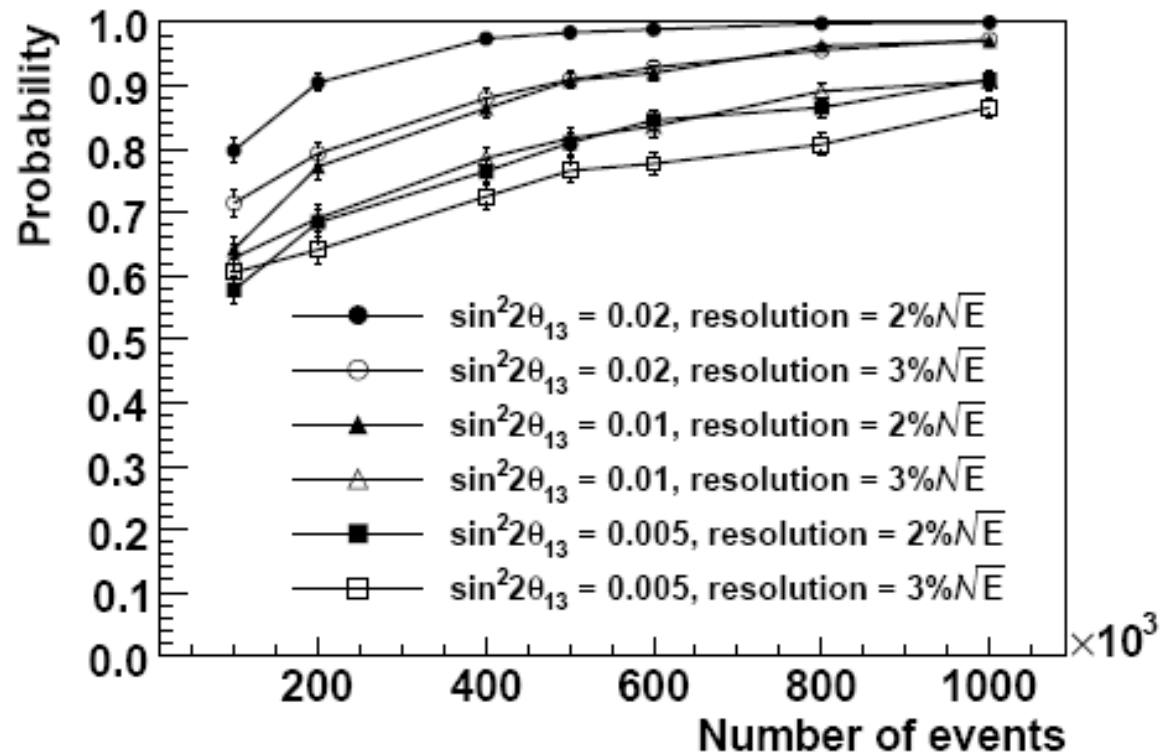

L. Zhan, YFW et.al, PRD79:073007, 2009

JUNO Project and the collaboration



- Project firstly approved in China in 2013 and later in other countries. Construction started in 2015
- Collaboration established in 2014, now >700 collaborators from 74 institutions in 17 countries/regions

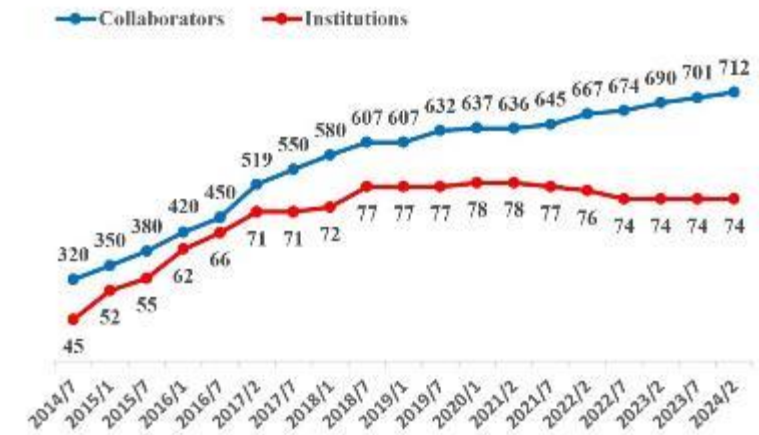

China	ChongQing University	China	NUDT	Pakistan	PINSTECH (PAEC)
China	CIAE	China	CUG-Beijing	Russia	INR Moscow
China	DGUT	China	ECUT-Nanchang City	Russia	JINR
China	Guangxi U.	China	CDUT-Chengdu	Russia	MSU
China	Harbin Institute of Technology	Czech	Charles U.	Slovakia	FMPICTU
China	IHEP	Finland	University of Jyvaskyla	Taiwan-China	National Chiao-Tung U.
China	Jilin U.	France	IJCLab Orsay	Taiwan-China	National Taiwan U.
China	Jinan U.	France	LP2i Bordeaux	Taiwan-China	National United U.
China	Nanjing U.	France	CPPM Marseille	Thailand	NARIT
China	Nankai U.	France	IPHC Strasbourg	Thailand	PPRLCU
China	NCEPU	France	Subatech Nantes	Thailand	SUT
China	Pekin U.	Germany	RWTH Aachen U.	U.K.	U. Warwick
China	Shandong U.	Germany	TUM	USA	UMD-G
China	Shanghai JT U.	Germany	U. Hamburg	USA	UC Irvine
China	IGG-Beijing	Germany	FZJ-IKP		

**A CERN
Recognised
Experiment
(RE34)**

- **Dig down is generally difficult, especially in the presence of water**
 - Largest water flow rate seen ~ 600m³/h
- **More water than expected:**
 - Geological survey shows that the rock resistivity is low
 - Bore holes found no water, but iron ore with a low grade
 - Water are mostly from cracks and faults, not directly from the surface
- **Mitigations:**
 - Drill holes to inject cement to seal water, and then drill holes for blasting
 - Elevate the hall by 35 m, shift the hall location to avoid cracks
 - Add a tunnel at the top of the hall to release the water pressure
- **Delayed by ~ 4 years**



Civil Construction Completed



- Rock ceiling ($\phi=50\text{m}$) is stable, rock temperature $\sim 31\text{ }^{\circ}\text{C}$,
- Temperature of the hall is controlled at $\sim 21\pm 1\text{ }^{\circ}\text{C}$

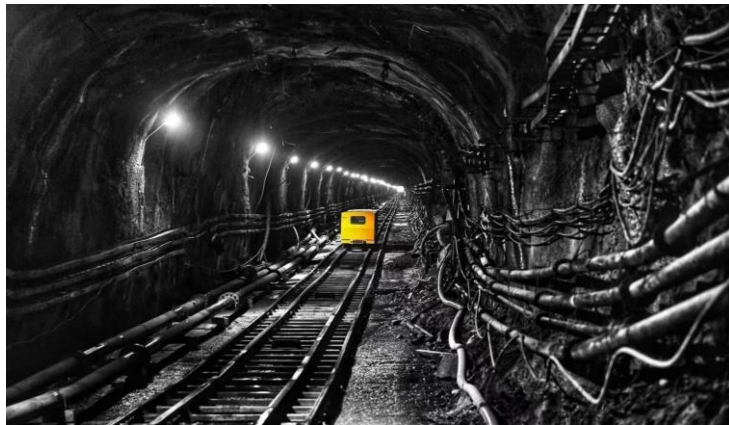

Sloped tunnel



LS hall



HVAC & Ventilation

JUNO Detector



- Target mass of 20 kt liquid scintillator → × 20 KamLAND, × 40 Borexino
- Energy resolution < 3%@ 1MeV → 1200 PE/MeV

	KamLAND	JUNO	PE Ratio
Photon Statistics	250 p.e./MeV	1200 p.e./MeV	5
PMT coverage	34%	75%	2.2
LS transparency	~12 m	> 20 m	~0.9
Light yield(anthracene)	30%	45%	~1.5
Detection Eff.(QE×CE)	~15%	30%	~ 2

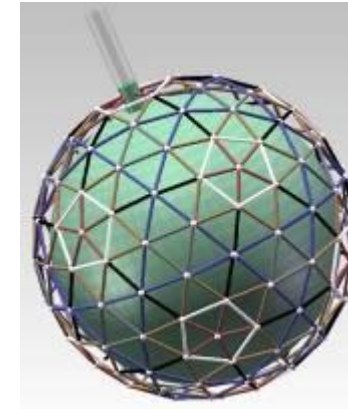

Steel frame+ Acrylic tank

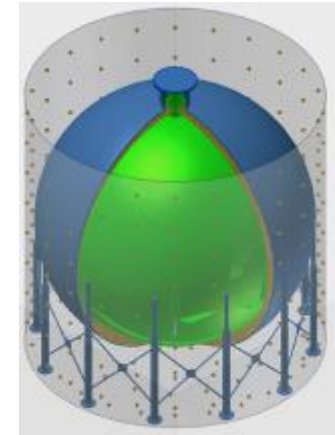

Steel tank+ Acrylic tank

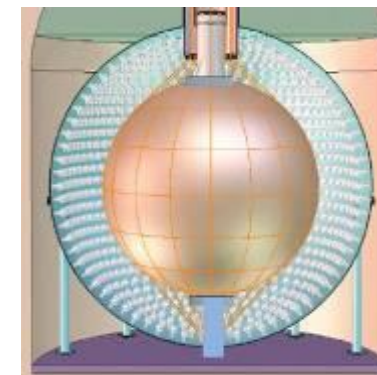

Steel Tank + Balloon

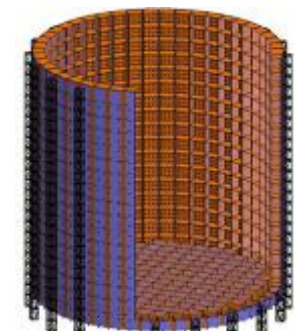

Steel Tank + Acrylic blocks

- **Technology R&D since 2009:**
 - Transparent & high light yield liquid scintillator
 - High detection efficiency 20" PMTs
 - Radiopurity U/Th/K < 10^{-17} g/g for 20 kt LS
- **Detector Design(tens options):**
 - Central target container: acrylic or balloon ?
 - Mechanical structure: steel frame or steel tank ?
 - Buffer layer: Water or Mineral oil ?

Concept of JUNO for Mass Ordering



- Two-layer structure for simplicity and cost: stainless steel frame + Acrylic tank
- Water as VETO and Buffer → radiopurity control of water

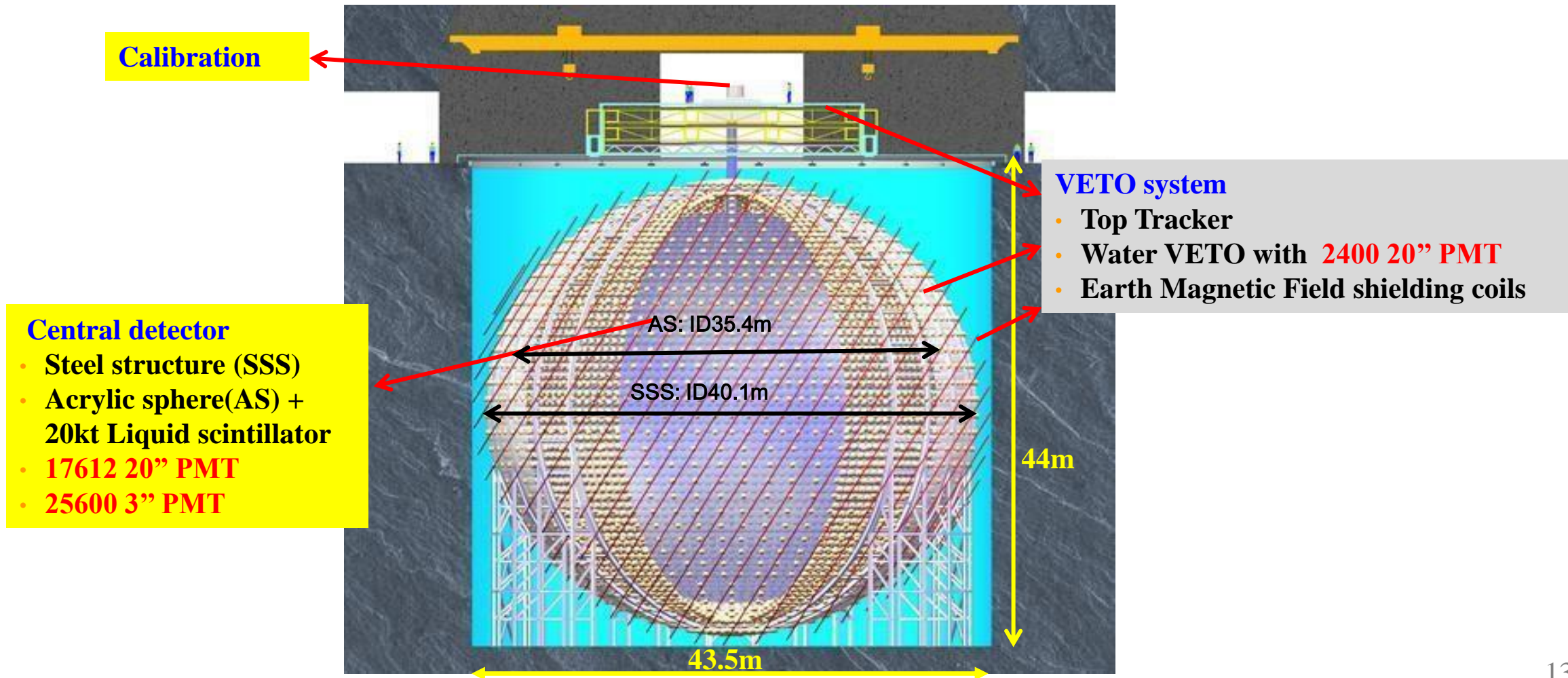

Central Detector



- **Acrylic sphere was chosen over balloon for safety, lower backgrounds and longevity**
- **Structure: SS frame with supporting bars to hold the acrylic sphere and to mount PMTs**
 - 263 Acrylic panels: $\sim 8\text{m} \times 3\text{m} \times 12\text{ cm}$
 - Thermally pressed and machined to the spherical shape
 - Panels are bonded through PMMA polymerization
 - 1.7m long steel anchor bolts welded to the concrete steel structure to hold the SS frame against the buoyancy
- **Main issues:**
 - Mechanical precision for PMT clearance $\sim 3\text{ mm}$
 - No welding, clearance between screw and hole $< 1\text{mm}$
 - Thermal expansion controlled at $21^\circ\text{C} \pm 1^\circ\text{C}$
 - Earth quake safety with liquid-solid coupling
 - Acrylic quality and strength:
 - ◆ Effects of aging, creep, crazing, etc. $< 20\%$ loss of strength
 - ◆ Bonding: fast and good quality, effects $< 20\%$ loss of strength
 - ◆ Stress of the supporting node $< 3.5\text{ MPa}$



Balloon test

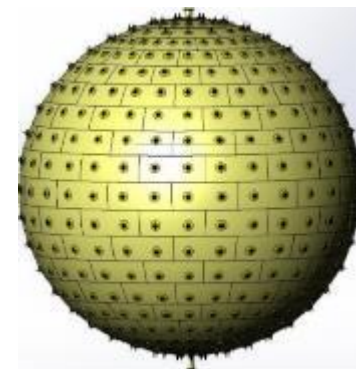
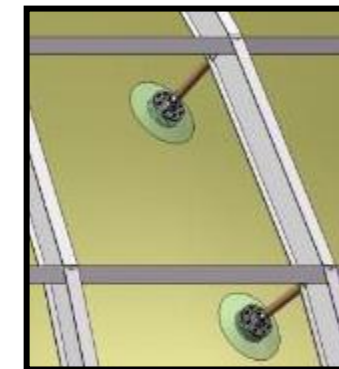

工况：自重+水压（内4.5m高度）

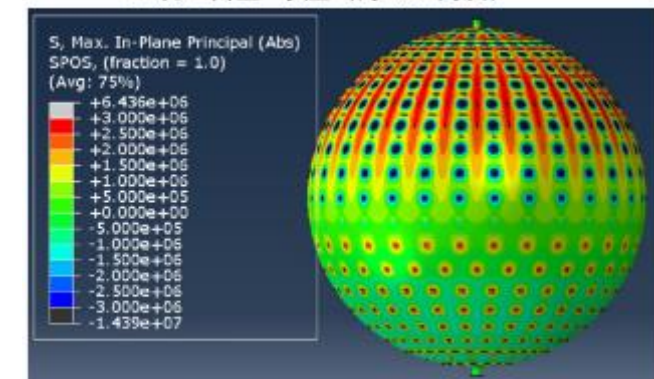

外表面应力情况

arXiv: 2311.17314

Central Detector Construction



- **SS structure completed except bottom 4 layers**
- **Acrylic panel production completed**
 - ✓ A special production line for low backgrounds (< 1 ppt U/Th/K)
 - ✓ Shaping, sanding/polishing, cleaning, machining and protection of panels by $50\mu\text{m}$ PE, while maintaining high transparency ($>96\%$) and low surface background (< 5 ppt U/Th)
- **Acrylic sphere construction on-going**
 - ✓ Lifting platform: frequently change the diameter and height
 - ✓ Acrylic sphere built from the top, 15/23 layers finished, defects repaired
 - ✓ SS bars connecting the acrylic and SS, sensors for stress monitoring

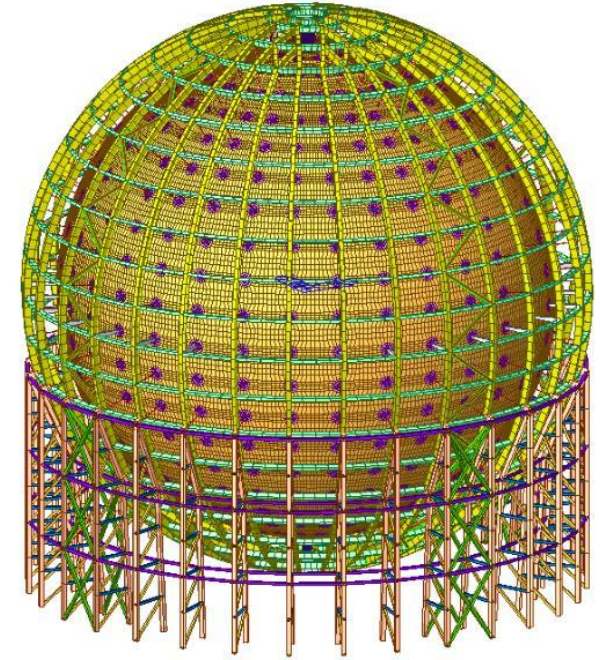

Hydraulic Lifting platform



The first five layers of Acrylic



Sanding and polishing

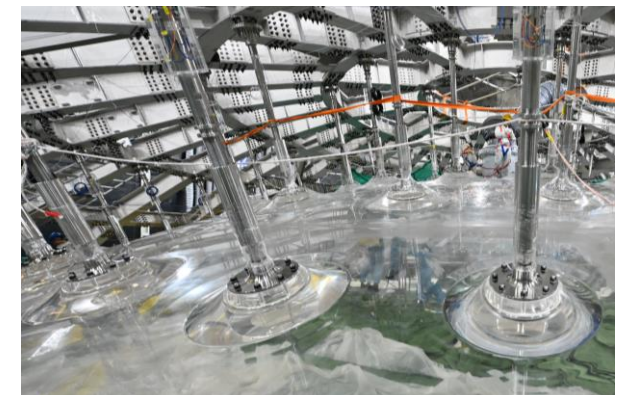

Bars between SS and acrylic



◆ Design:

- ⇒ 700m overburden → $R_\mu = 0.004 \text{ Hz/m}^2$, $\langle E_\mu \rangle = 207 \text{ GeV}$
- ⇒ 35 kt water to shield backgrounds from the rock
- ⇒ 2400 20" PMTs in water to tag & reconstruct cosmic muons
- ⇒ Top tracker: refurbished OPERA scintillators

◆ Water pool lining: 5mm HDPE to keep the clean water and to stop Rn from the rock

◆ Earth magnetic field compensation coil

100t/h pure water production for $U/Th/K < 10^{-14}$ g/g and $Rn < 10 \text{ mBq/m}^3$, attenuation length $> 40\text{m}$, temperature controlled to $(21 \pm 1) \text{ }^\circ\text{C}$



Ultrapure water system

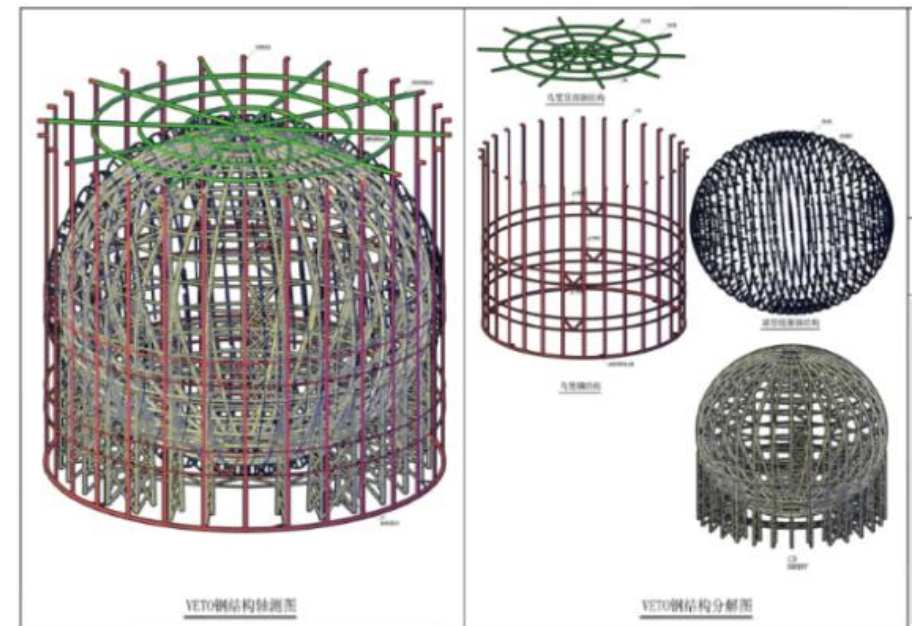
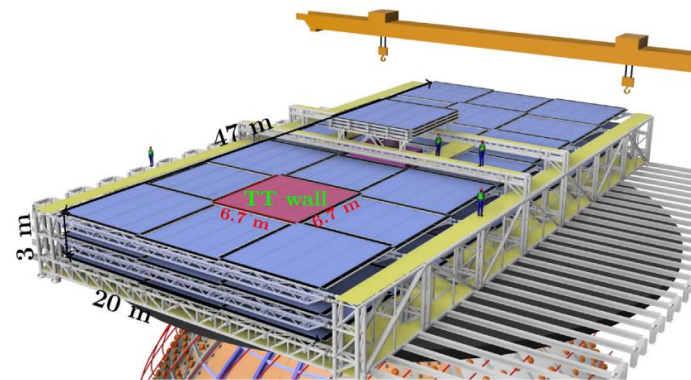
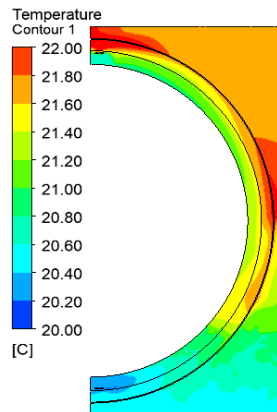

High QE PMT R&D



- ◆ Use Micro-Channel Plates (MCPs) instead of dynode for better collection efficiency (CE)
- ◆ IHEP & NNVT jointly developed technologies & prototypes
 - Higher collection efficiency
 - High efficiency photocathode, low backgrounds glass, ...
 - High production yield, automatic mass production
- ◆ Hamamatsu developed 20" SBA PMTs
- ◆ Purchase optimized considering performance, cost, risk, etc.
 - MCP-PMT: 15000
 - Dynode PMT(Hamamatsu): 5000

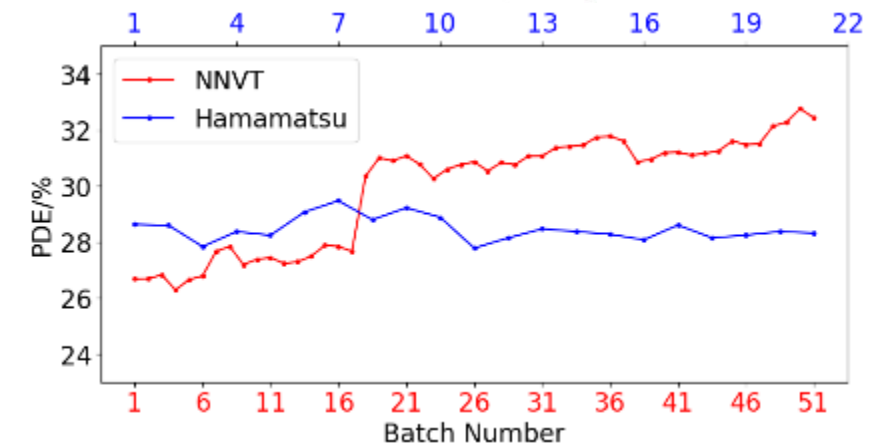
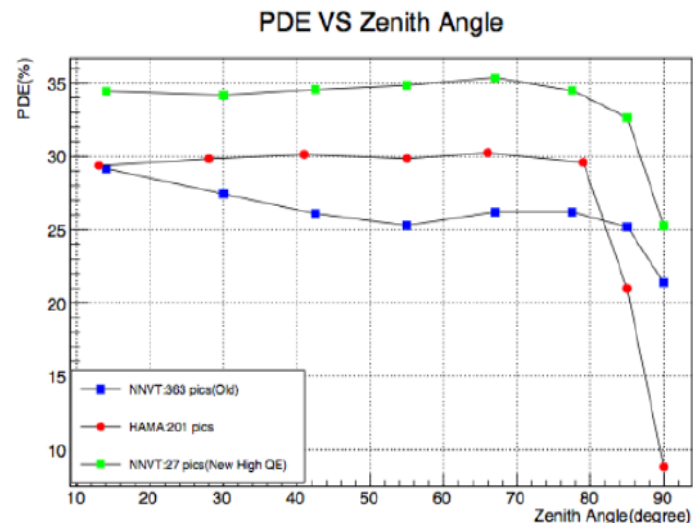
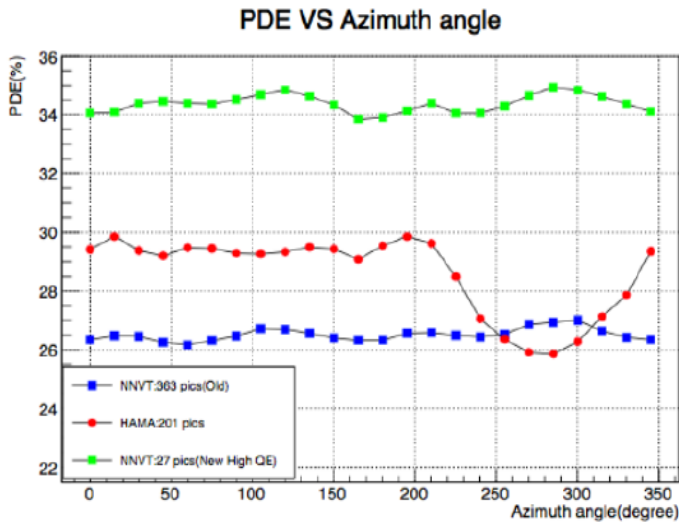
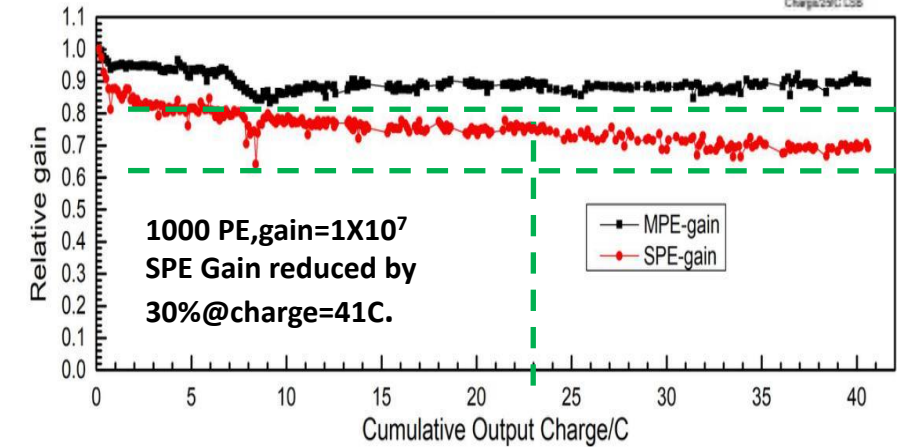
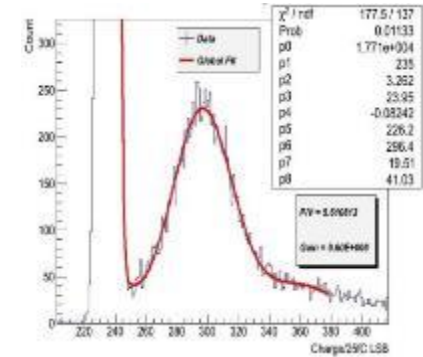

PMT Instrumentation



Potted PMT



PMTs after potting



Implosion test of PMTs on the module structure

- All PMTs delivered and their performance tested OK
- Water proof potting
 - Required failure rate <math><0.5\%/6\text{ years}</math>
 - Technology invented, aging and pressurized tests are satisfactory
- Implosion protection JINST 18 (2023), P02013
 - Acrylic top & SS bottom
 - Final test: no chain reactions
- Mass production successfully completed

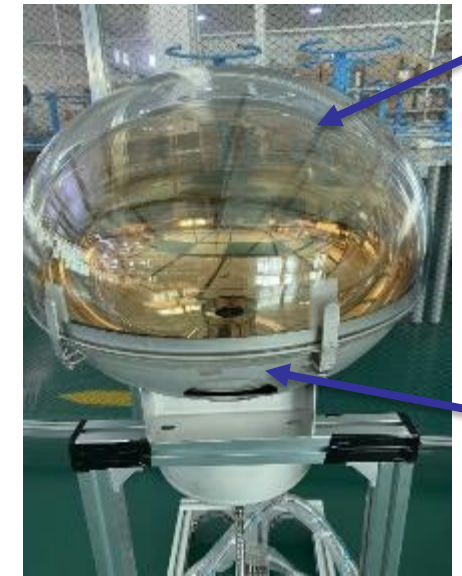

Acrylic cover

Stainless Steel cover

LPMT Electronics



- ◆ ~20000 ch., each with 100 m long cable
- ◆ Dynamic range: 1- 4000 PE
- ◆ Noise: < 10% @ 1 PE
- ◆ Resolution: <10%@1PE, <1%@100 PE
- ◆ Failure rate: < 0.5%/6 years

- Joint PMT-electronics-DAQ-software test shows that all installed PMTs and related systems work well
- Noise level is ~ 0.05 PE: good grounding and shielding

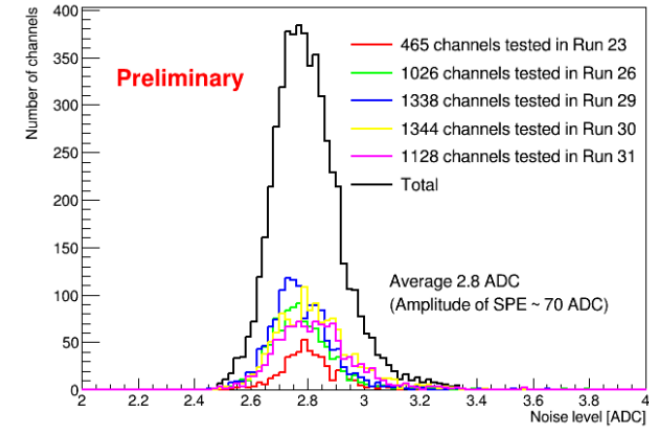

Solution:

- 1 GHz FADC in an underwater box (3 ch./box), connected to PMTs by water proof connectors and <2m long cables
- All cables in corrugated SS pipes for water proof

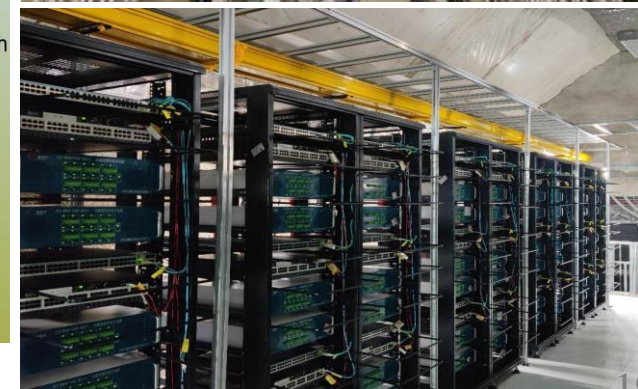
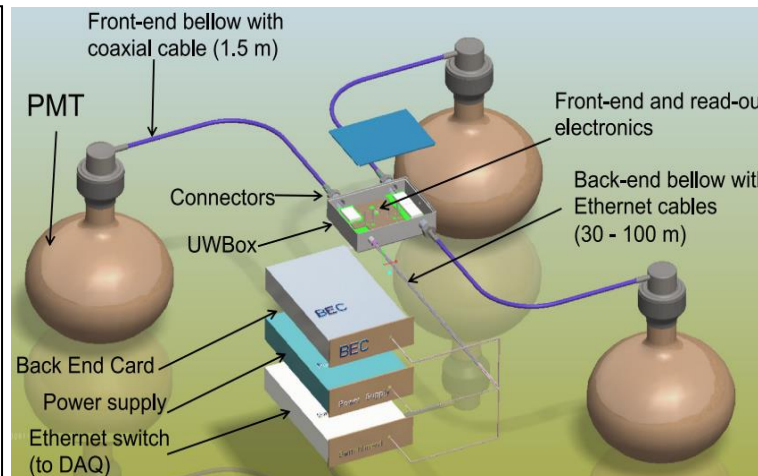
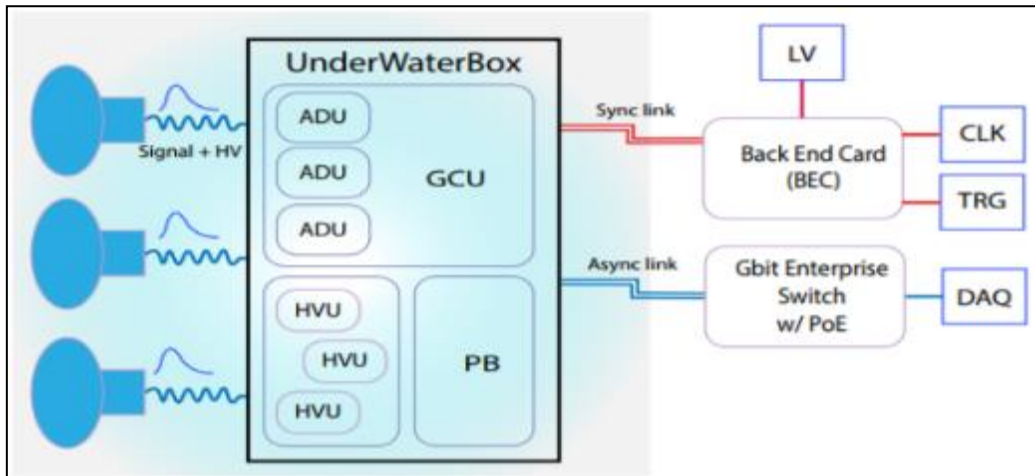

Small PMT system



- Goal: 3% more light, higher dynamic range for muons, uniformity and linearity calibration for large PMTs, ...
- Mass production and waterproofing of 26,000 3.1" PMTs (XP72B22) from HZC Photonics completed, and tested OK
- Electronics: 200 underwater boxes, each for 128 PMTs read by ASIC Battery Cards (ABC), each with 8 CatiROC chips
- Installation and commissioning under way

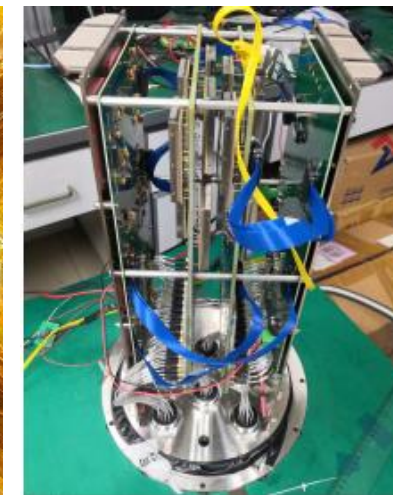

JINST 16 (2021), P05010

PMTs and electronics

System overview: 200 boxes × 128 PMTs

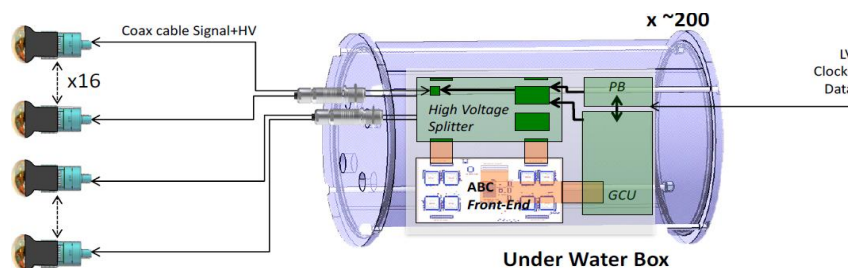

Performances highlight of all 26,000 PMTs

NIMA 1005 (2021) 165347

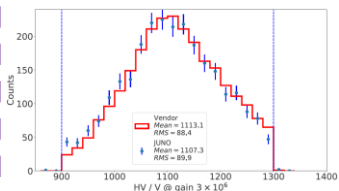

HV: 900-1325V

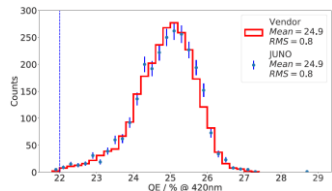

$\overline{QE} = 24.9\%$

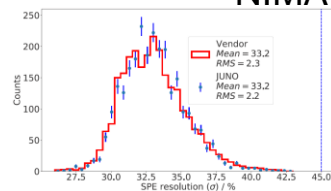

$\overline{\sigma_{SPE}} = 33.2\%$

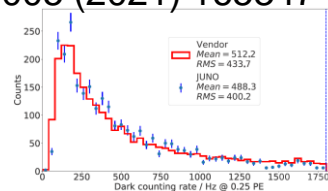

$\overline{DCR} \approx 500 \text{ Hz}$

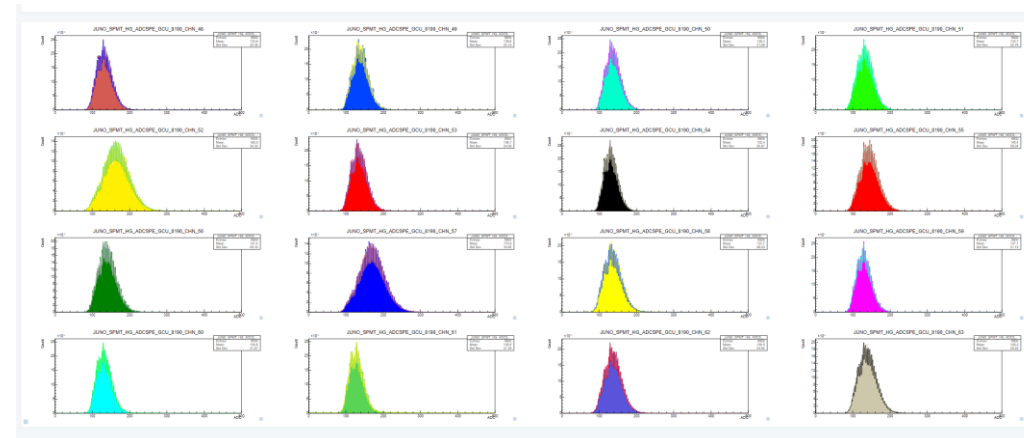

First commissioning data:
SPE spectra of a group of 16 PMTs

PMT Statistics and the Installation



7,225 LPMTs and 9,293 SPMTs (~1/3) installed and tested OK

	LPMT (20-inch)		SPMT (3-inch)
	Hamamatsu	NNVT	HZC
Quantity	5000	15012	25600
Charge Collection	Dynode	MCP	Dynode
Photon Detection Efficiency	28.5%	30.1%	25%
Dynamic range for [0-10] MeV	[0, 100] PEs		[0, 2] PEs
Coverage	75%		3%
Reference	Eur.Phys.J.C 82 (2022) 12, 1168		NIM.A 1005 (2021) 165347



Radiopurity Control



Radiopurity of raw materials *JHEP 11 (2021) 102*

Singles (R < 17.2 m, E > 0.7 MeV)	Design [Hz]	Change [Hz]	Comment
LS	2.20	0	
Acrylic	3.61	-3.2	10 ppt -> 1 ppt
Metal in node	0.087	+1.0	Copper -> SS
PMT glass	0.33	+2.47	Schott -> NNVT/Ham
Rock	0.98	-0.85	3.2 m -> 4 m
Radon in water	1.31	-1.25	200 mBq/m ³ -> 10 mBq/m ³
Other	0	+0.52	Add PMT readout, calibration sys
Total	8.5	-1.3	

Radiopurity control of raw material:

- ✓ Careful material screening
- ✓ Meticulous Monte Carlo Simulation
- ✓ Accurate detector production handling

Better than spec. by 15%

Good enough for reactor ν 's

LS for solar neutrinos:

U/Th < 10⁻¹⁷ g/g, ⁴⁰K < 10⁻¹⁸ g/g, ⁸⁵Kr < 50 μ Bq/m³,
²²⁶Ra < 5 \times 10⁻²⁴ g/g (0.1 μ Bq/m³), ²¹⁰Pb < 10⁻²⁴ g/g (²²²Rn < 5 mBq/m³)

Recirculation seems impossible for JUNO, not like Borexino, KamLAND, SNO+,...

Radiopurity control of LS:

- Leak check (single component < 10⁻⁸ mbar·L/s) of all joints to reduce ²²²Rn and ⁸⁵Kr ✓
- Cleaning and wash of all pipes, vessels to remove dust (check water cleanness) ✓
- Clean room environment during installation ✓
- Surface treatment of the acrylic vessel (Rn daughters) ✓
- LS filling strategy ✓

Cleanness of Environment

◆ Average radon and cleanliness:

- Radon concentration: $\sim 160 \text{ Bq/m}^3$ in the EH, $\sim 140 \text{ Bq/m}^3$ in the LS hall
- Cleanliness: class 20,000

Region	Level
1	Class 100,000
2	Class 10,000
3	Class 1000

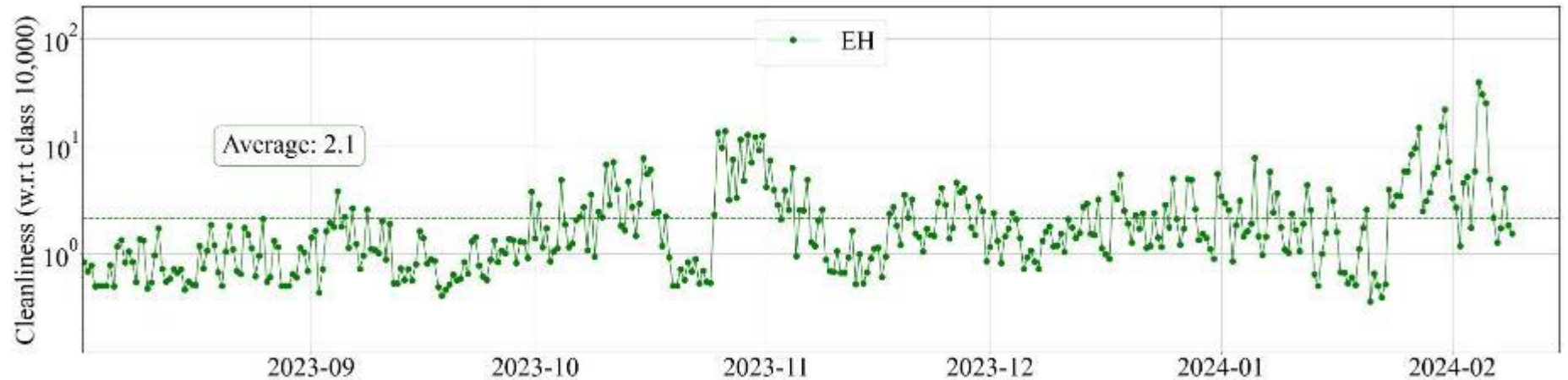
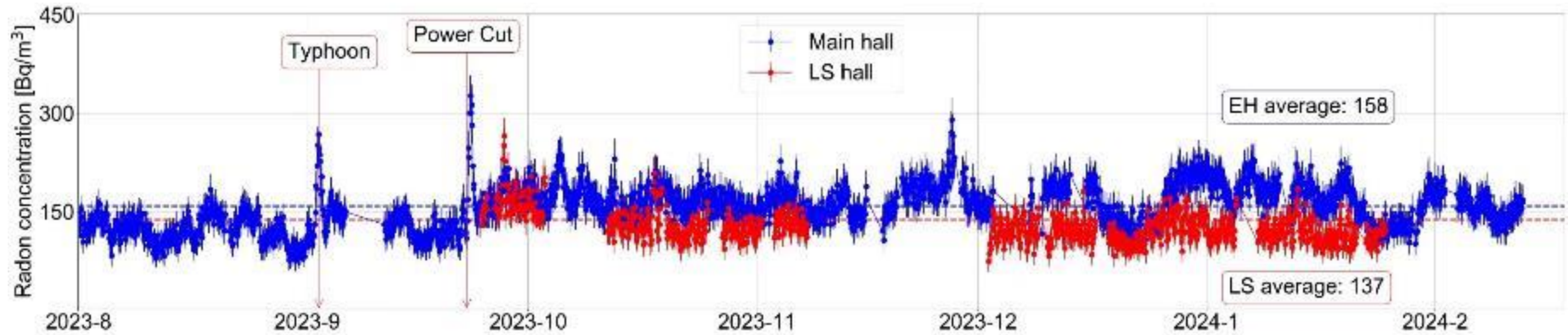
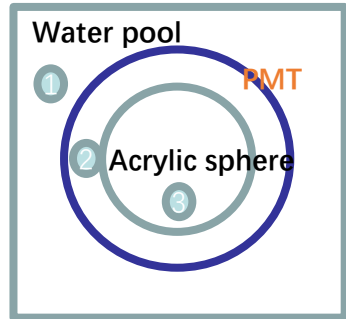

Radon concentration
in air: $< 200 \text{ Bq/m}^3$

Liquid Scintillator



◆ Recipe: Based on Daya Bay experience

- ⇒ LAB for transparency and safety
- ⇒ R&D for highest light yield:
 - ✓ A Daya Bay module for test (*NIMA 988 (2021) 164823*)
 - ✓ extrapolation to the JUNO size using a new LS optical model (*NIMA 967 (2020) 163860*)
- ⇒ Final result: **LAB + 2.5g/L PPO + 3 mg/L bis-MSB**

◆ Production:

- ⇒ ~50t PPO delivered, U/Th < 0.1 ppt; 20kt LAB to be delivered, U/Th ~ 1 ppq
- ⇒ LAB attenuation length > 24m, LS attenuation length > 20m

Experimental Hall 1

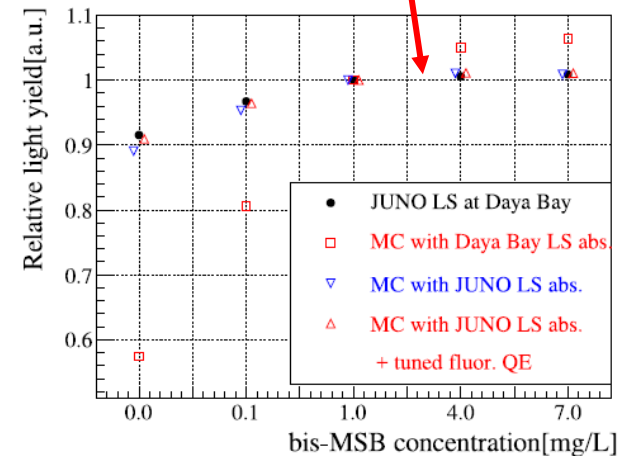
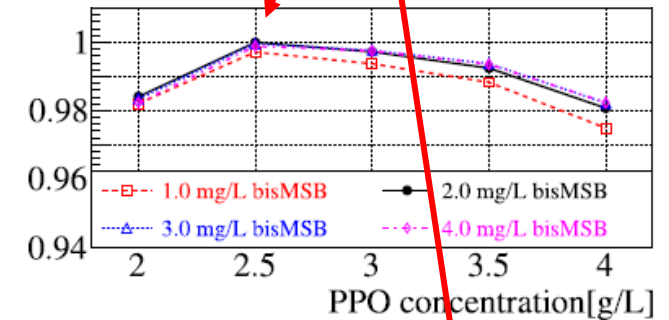
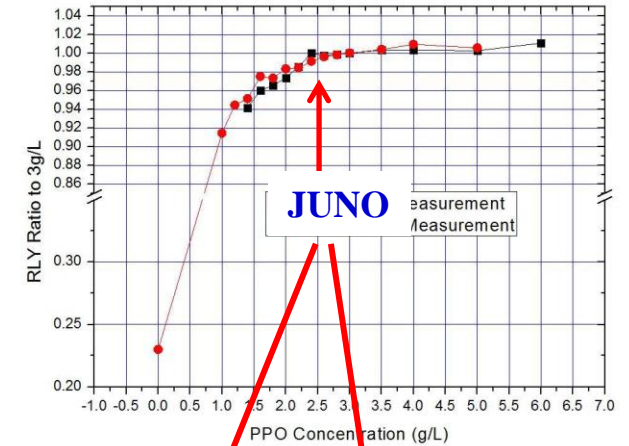
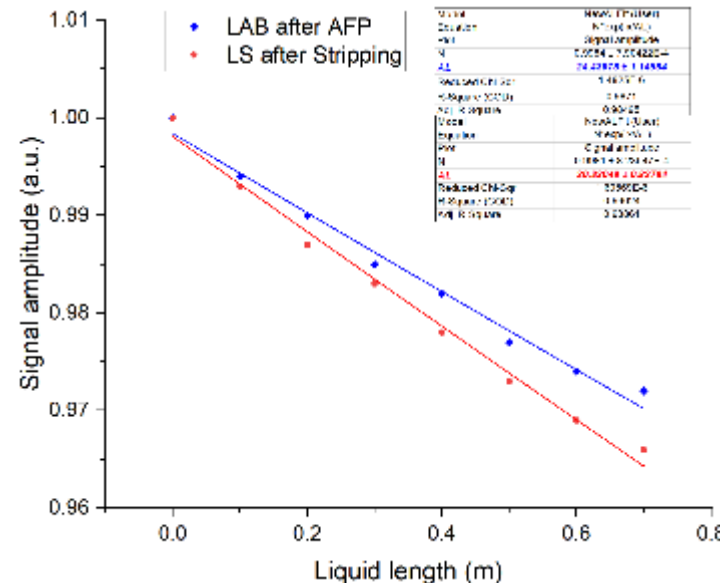

Liquid Scintillator Production and Purification



Four purification plants + LS Mixing + QA/QC + high purity N₂ and water production plant to guarantee radio-purity and transparency



5000 m³ LAB storage tank



1) Al₂O₃ for optical transparency



2) Distillation for radiopurity



Mixing LAB with PPO and bis-MSB

85%

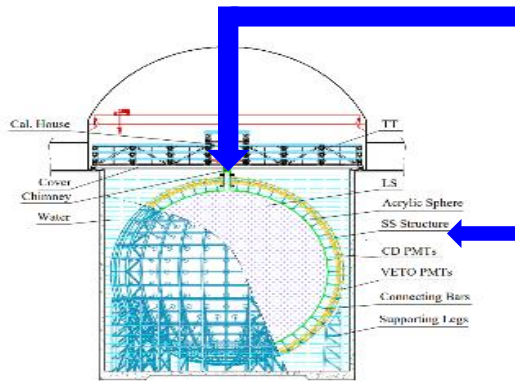

OSIRIS to monitor the LS quality

15%



4) Gas stripping to remove Rn and O₂



3) Water extraction to remove radioactive impurities

1800 m SS pipes to underground

All plants are individually tested, and all requirements are satisfied

OSIRIS: LS Radiopurity Verification before Filling

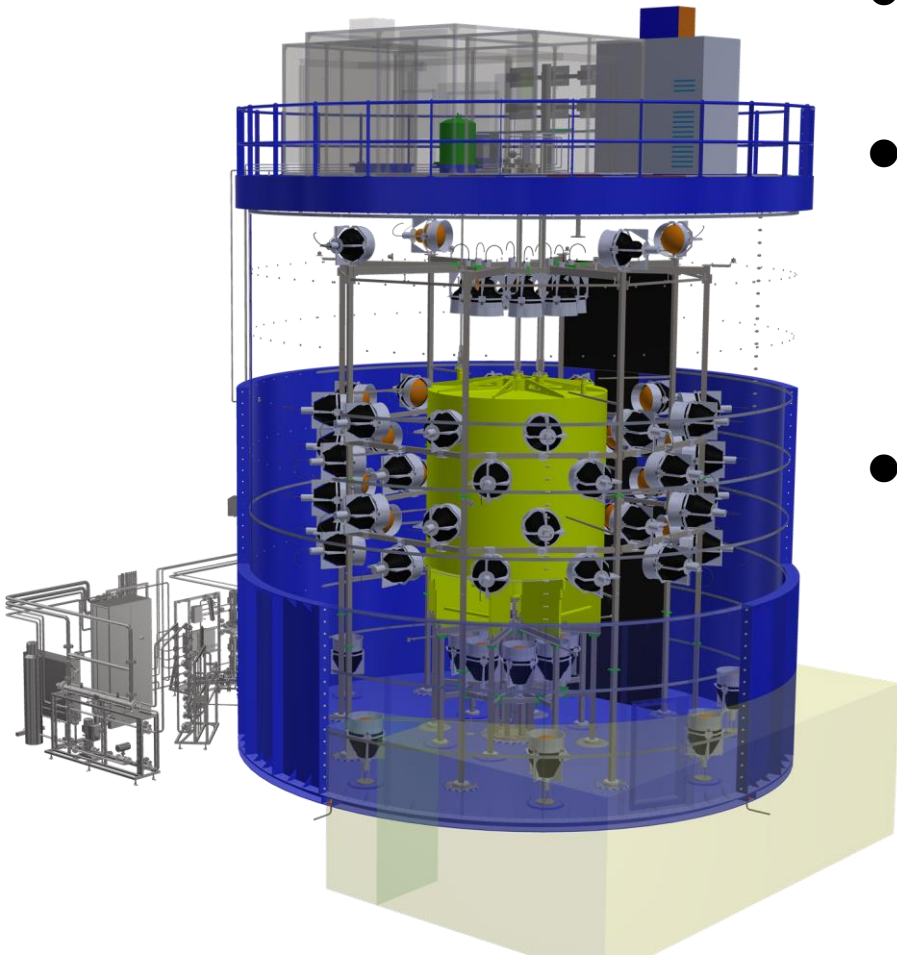

- A dedicated pre-detector to verify the **radioactivity levels of LS**
- 20 tons of LS in 3m-by-3m acrylic vessel, 76 MCP-PMTs, 3m of water shielding → **first test run successful**
- First batch of JUNO LS filled into the detector on March 11
 - **U/Th tagging by Bi-Po-214** coincidence, which is now still dominated by ^{222}Rn → have to wait several ^{222}Rn lifetimes ($\tau=5.5$ days) to reach U/Th $<10^{-15}$ g/g
 - Analysis for ^{14}C , ^{210}Po , ... in progress

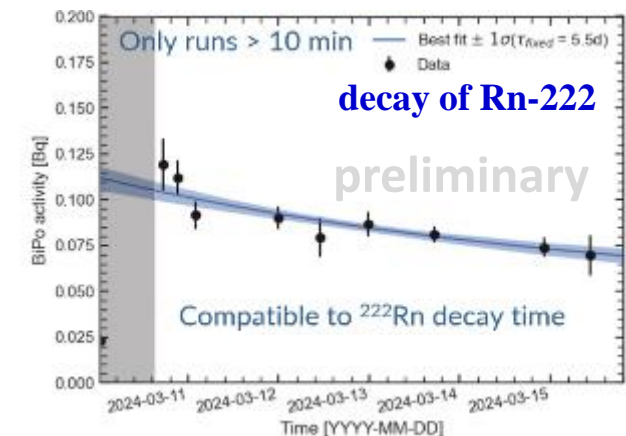
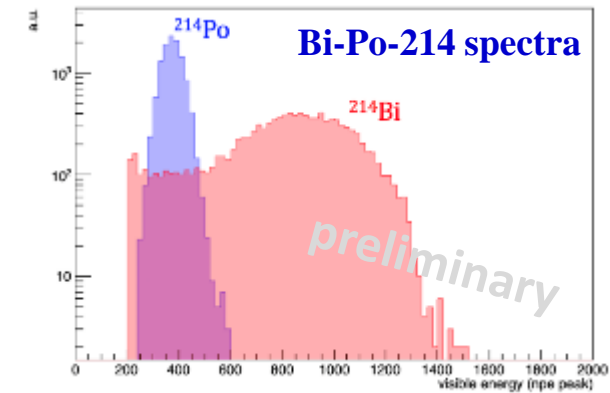
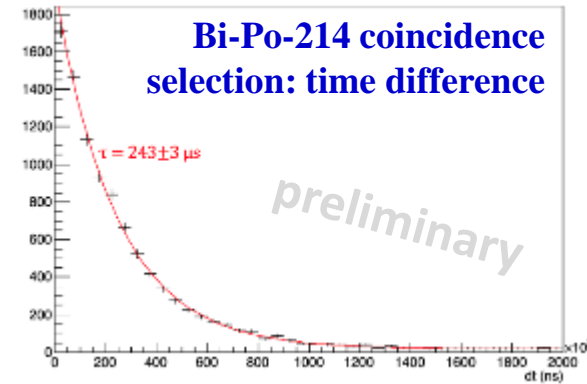

Commissioning of the Liquid Scintillator system



Screened by ICP-MS and checked by NAA analysis

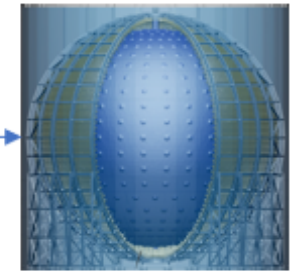
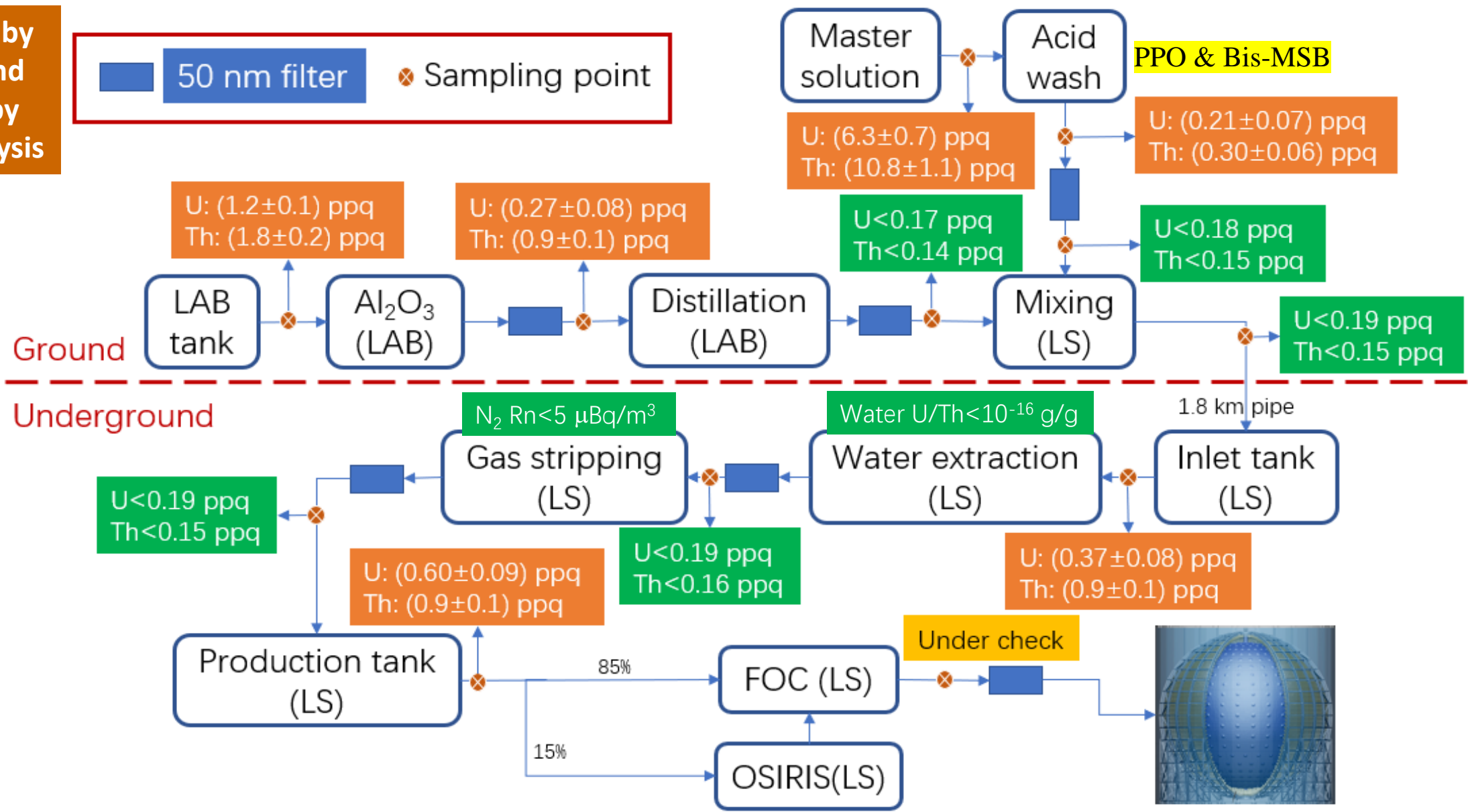

Final Cleaning Plan and Liquid Scintillator Filling Scheme



Reduce dust to class 1000, Rn by $\div 10$

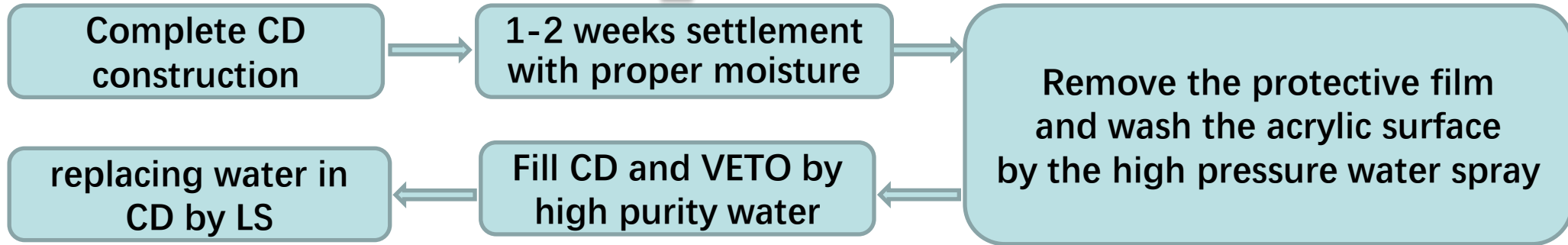

Water for CD: U/Th $< 10^{-15}$ g/g, $^{226}\text{Ra} < 0.1$ mBq/m³
 Water for VETO: U/Th $< 10^{-14}$ g/g

LS filling (7m³/h)

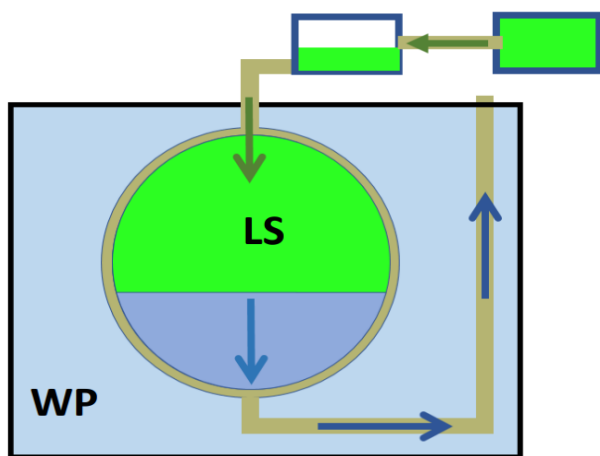

Drain water (7m³/h)

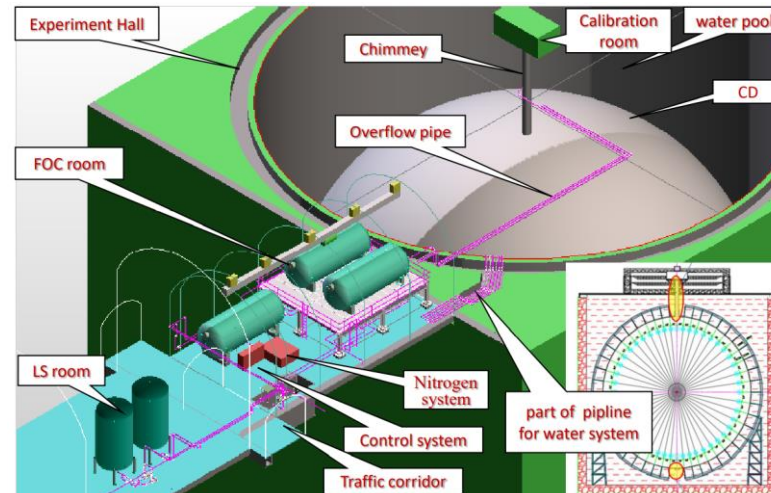

Calibration

1D, 2D, 3D scan systems with multiple calibration sources

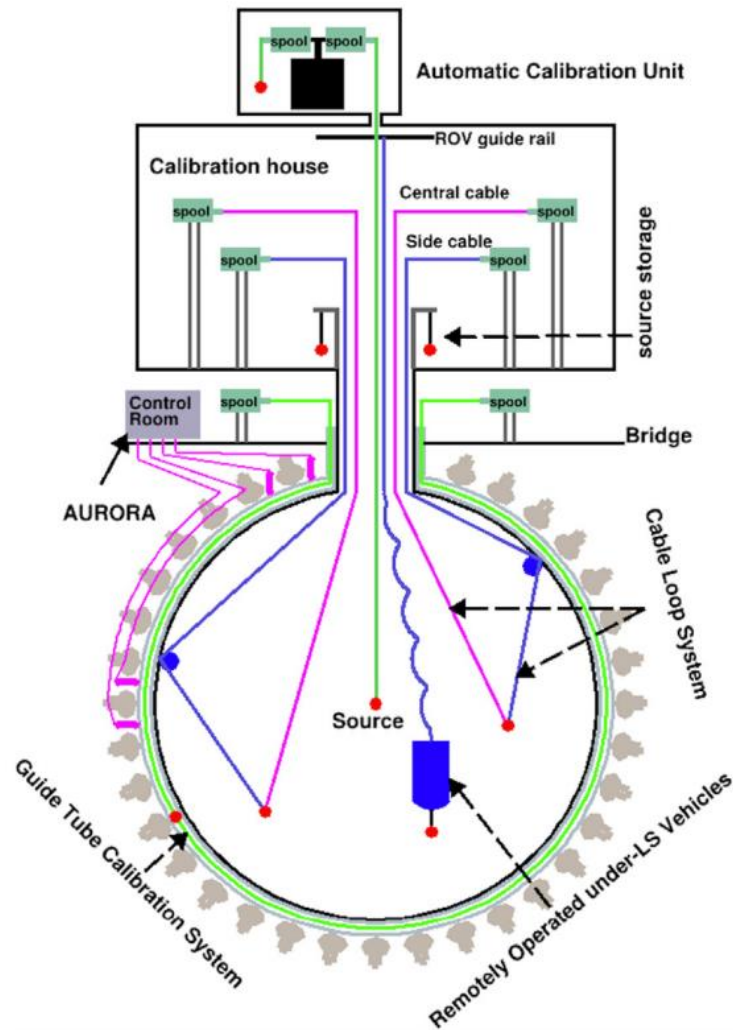

All systems ready for installation

- Calibrate energy scale and non-linearity to better than 1% using γ peaks and cosmogenic ^{12}B beta spectrum
- Successful at Daya Bay and other exp.s

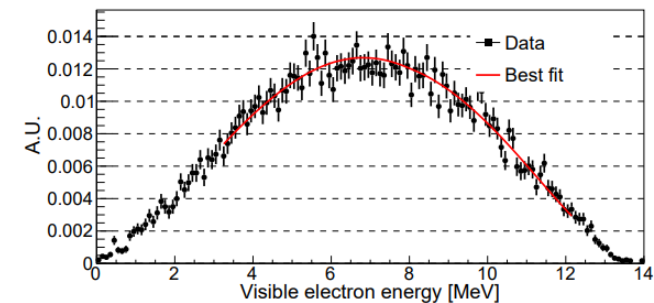
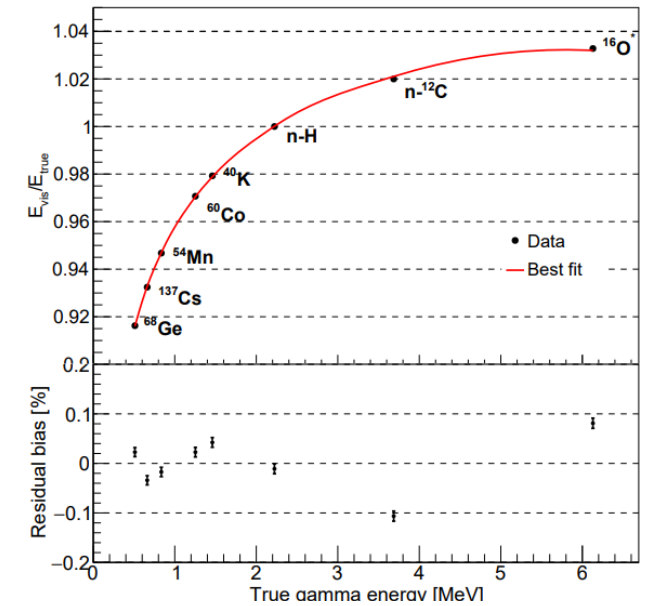

Installation

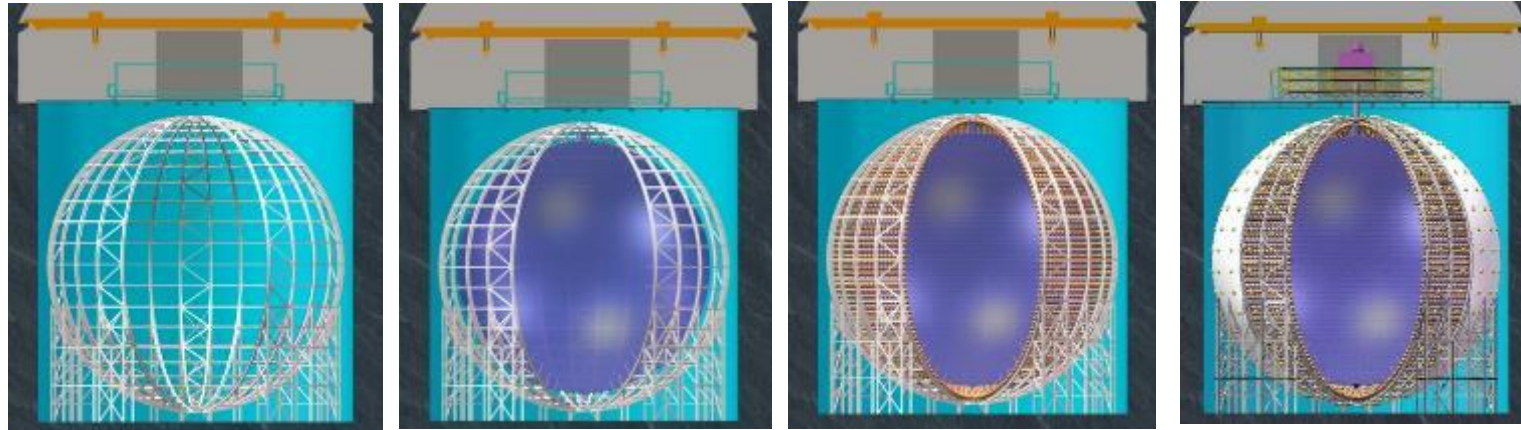

SS MAIN STRUCTURE

+ACRYLIC SPHERE

+PMT

+VETO/CALIBRATION

SS Main Structure

Clean

Water and LS Filling

Acrylic sphere Installation

Bridge, cover, Cali., TT in parallel

PMT Module

Pool lining、Earth magnetic field shielding coils、Tyvek etc.

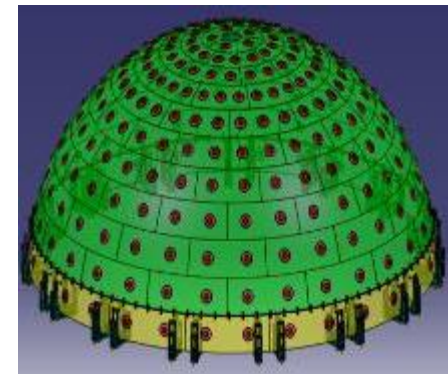
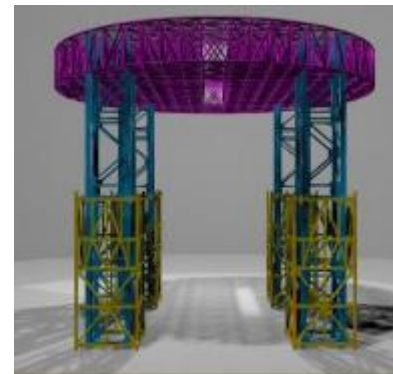
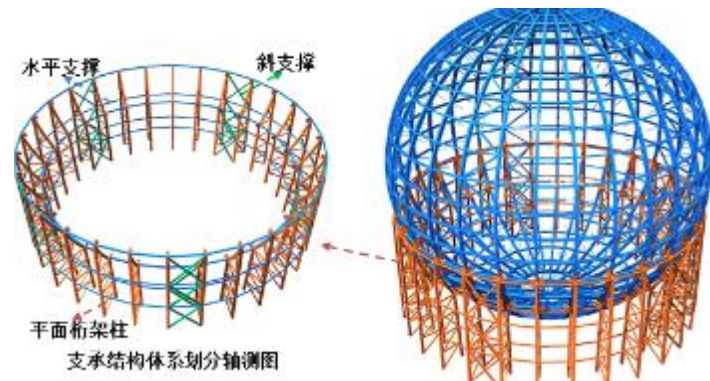



Expected Performance

- Bkg. in LS can reach U/Th/K < 10^{-15} g/g for **MH**
- 10^{-17} g/g is feasible for **solar ν** and $0\nu\beta\beta$ **decays**
- From measured PMT, LS and acrylic properties, the energy resolution will be < **3%@1MeV**, based on full simulation, calibration and reconstruction

$$\frac{\sigma}{E_{vis}} = \sqrt{\left(\frac{2.614\%}{\sqrt{E_{vis}}}\right)^2 + 0.64\%^2 + \left(\frac{1.205\%}{E_{vis}}\right)^2}$$

↓ **Photon statistics**
↓ **Constant term**
↓ **Annihilation-induced γ s**

↓ **Dark noise**

Main changes vs design (*JHEP03(2021)004*):

- Photon detection eff.: 27% → 30%
(EPJC 82 (2022) 12, 1168)
- New PMT optical model: +8%
(EPJC 82 329 (2022))
- *New central detector geometry and LS: 3%*

Total photon statistics: ~1660/MeV

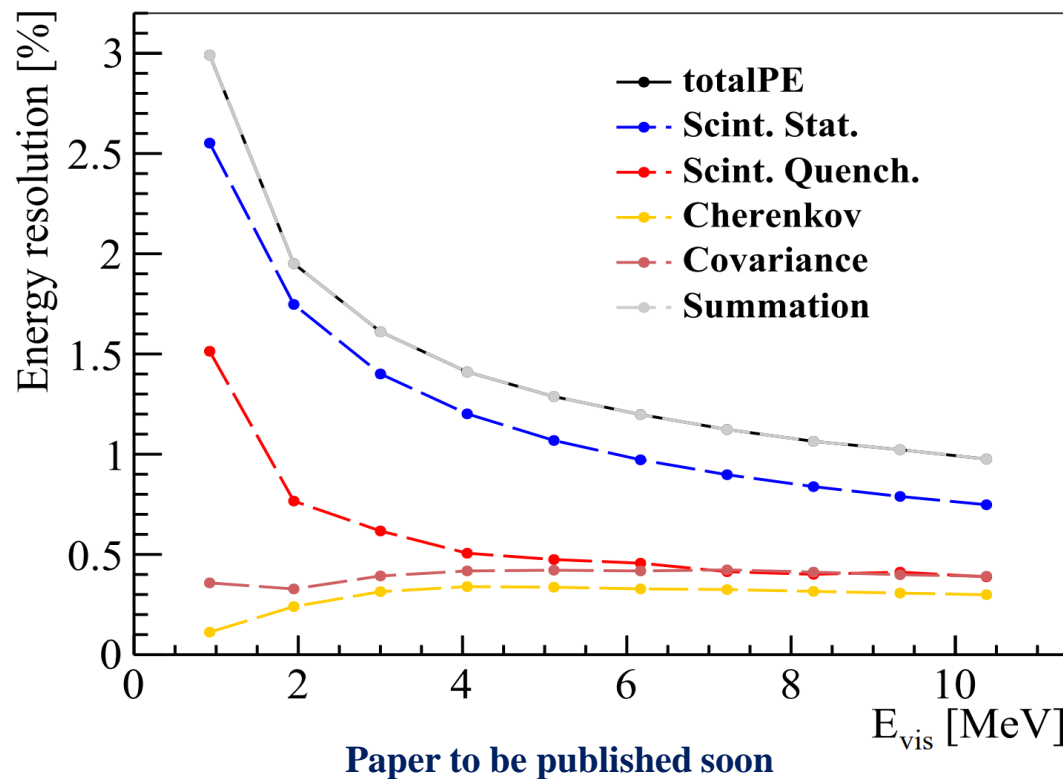

Reactor Antineutrino Spectrum



CPC 46 (2022) 12, 123001

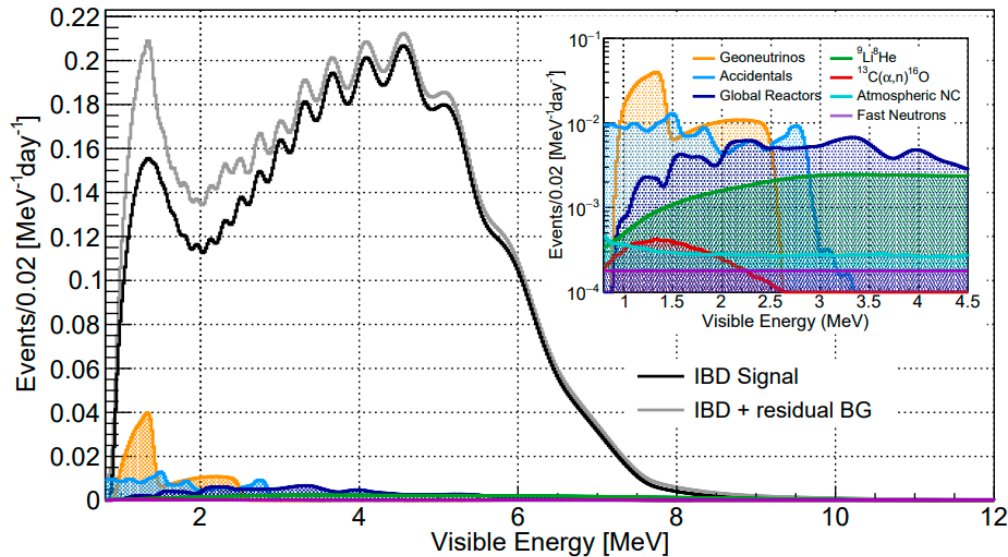

Event type	Rate [/day]	Relative rate uncertainty	Shape uncertainty
Reactor IBD signal	60 → 47	-	-
Geo- ν 's	1.1 → 1.2	30%	5%
Accidental signals	0.9 → 0.8	1%	negligible
Fast-n	0.1	100%	20%
${}^9\text{Li}/{}^8\text{He}$	1.6 → 0.8	20%	10%
${}^{13}\text{C}(\alpha, n){}^{16}\text{O}$	0.05	50%	50%
Global reactors	0 → 1.0	2%	5%
Atmospheric ν 's	0 → 0.16	50%	50%

JUNO physics book (*J. Phys. G43:030401(2016)*) → updated analysis

Updates for the spectra and rates since JUNO (2016)

- ☹️ 2 reactor cores missing in Taishan
- ☹️ Better muon veto strategy
- ☹️ Improved energy resolution:
3.0% @1MeV → 2.9% @1MeV

- ☹️ More realistic estimate on signals and backgrounds
- ☹️ Slightly less overburden
- ☹️ Lower radioactivity background based on latest measurements

JUNO-Tao



- ◆ To measure the reactor neutrino spectrum as a reference to JUNO
 - ⇒ better resolution to reduce fine structure effects and spectrum uncertainties
 - ⇒ Improve nuclear database, search for sterile neutrinos
- ◆ Idea: Gd-loaded LS @-50°C + SiPM
 - ⇒ 700k/year@44m from the core(4.6 GW), with ~10% bkg.
 - ⇒ Energy resolution: ~1.5%/√E, 4500 p.e./MeV
 - ⇒ 10 m² SiPM (>94% coverage) w/ PDE > 50%
 - ⇒ Operating at -50 °C to reduce the SiPM dark rate by 10³ to 100 Hz/mm²
 - ⇒ 2.8 ton(1t fiducial volume) new type of Gd-LS for -50 °C
- ◆ Component production mostly completed

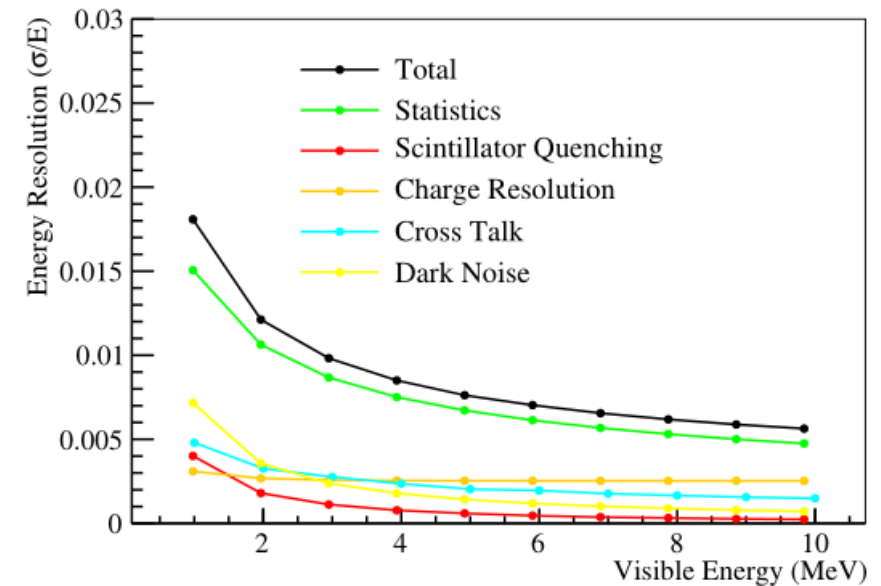
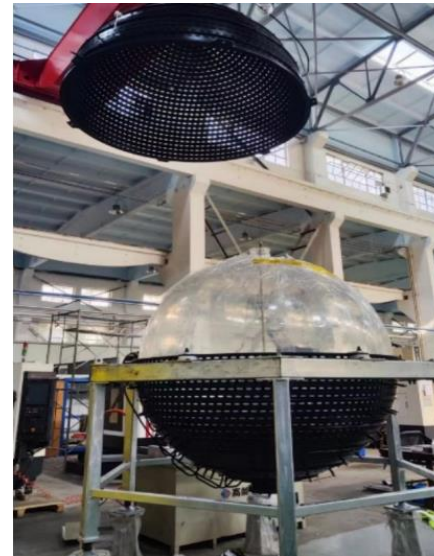
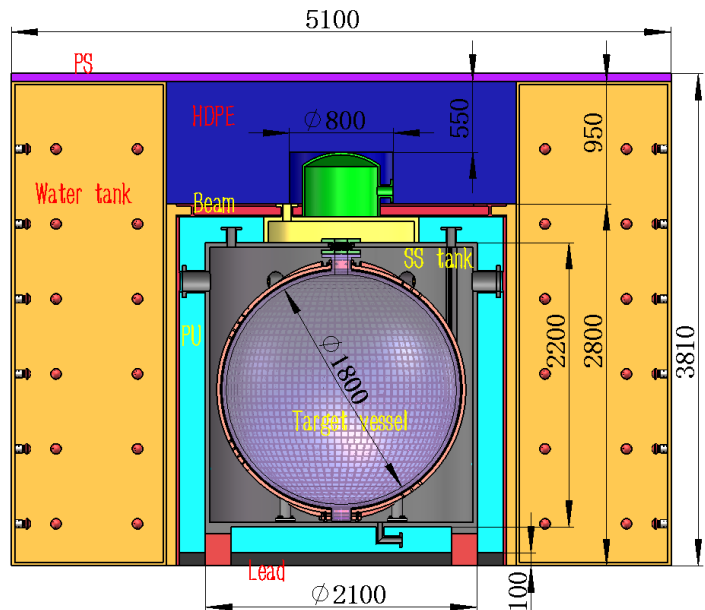
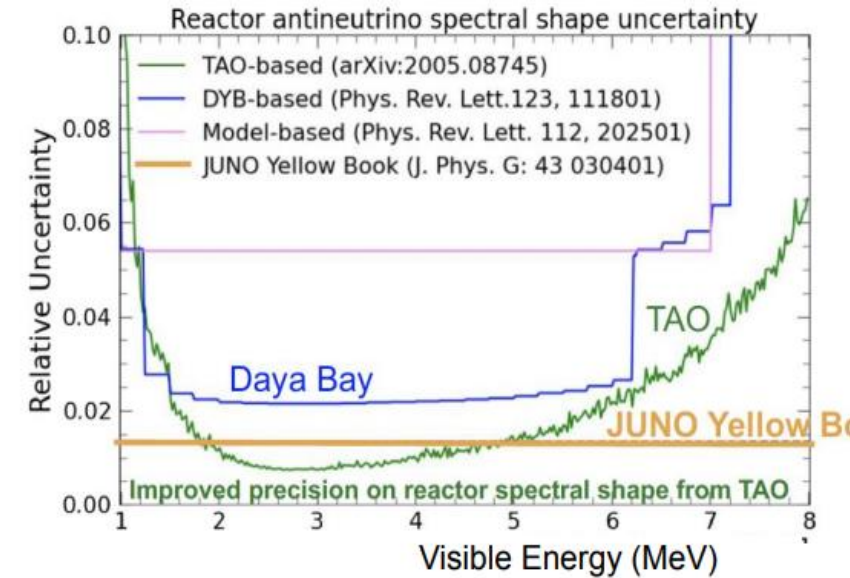

Neutrino Mass Ordering

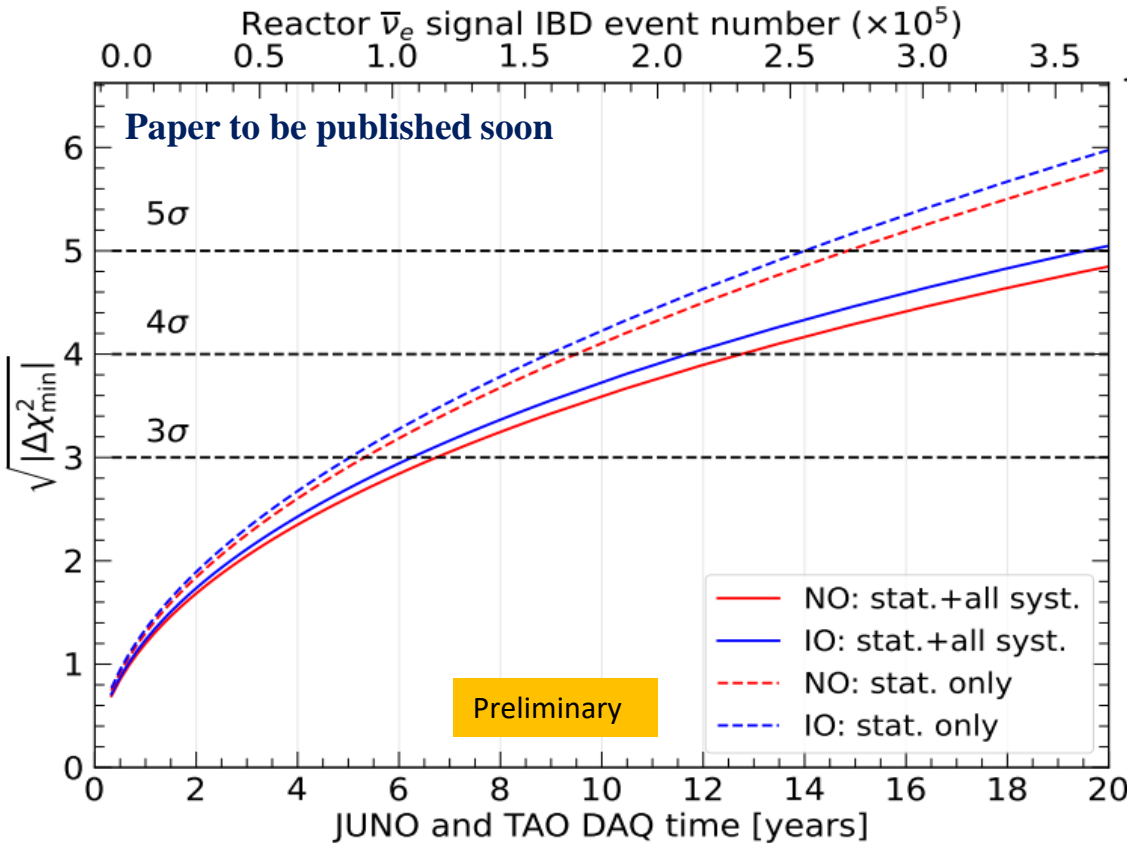

	Design *	Now
Thermal Power	36 GW _{th}	26.6 GW _{th} (26%↓)
Signal rate	60 /day	47.1 /day (22%↓)
Overburden	~700 m	~ 650 m
Muon flux in LS	3 Hz	4 Hz (33%↑)
Muon veto efficiency	83%	91.6% (11%↑)
Backgrounds	3.75 /day	4.11 /day (10%↑)
Energy resolution	3.0% @ 1 MeV	2.95% @ 1 MeV (2%↑)
Shape uncertainty	1%	JUNO+TAO
3σ NMO sens. Exposure	< 6 yrs × 35.8 GW_{th}	~ 6 yrs × 26.6 GW_{th}

* J. Phys. G 43:030401 (2016)

JUNO NMO median sensitivity: **3σ (reactors only) @ ~6 yrs * 26.6 GW_{th} exposure**

Combined reactor+atmospheric neutrino analysis **in progress**: further improve the NMO sensitivity

Atmospheric Neutrinos

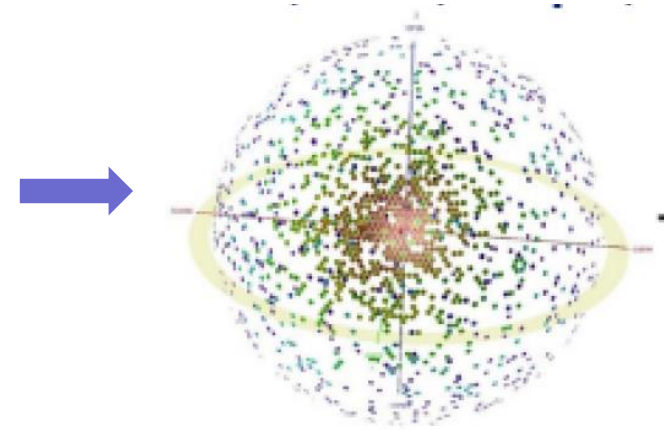
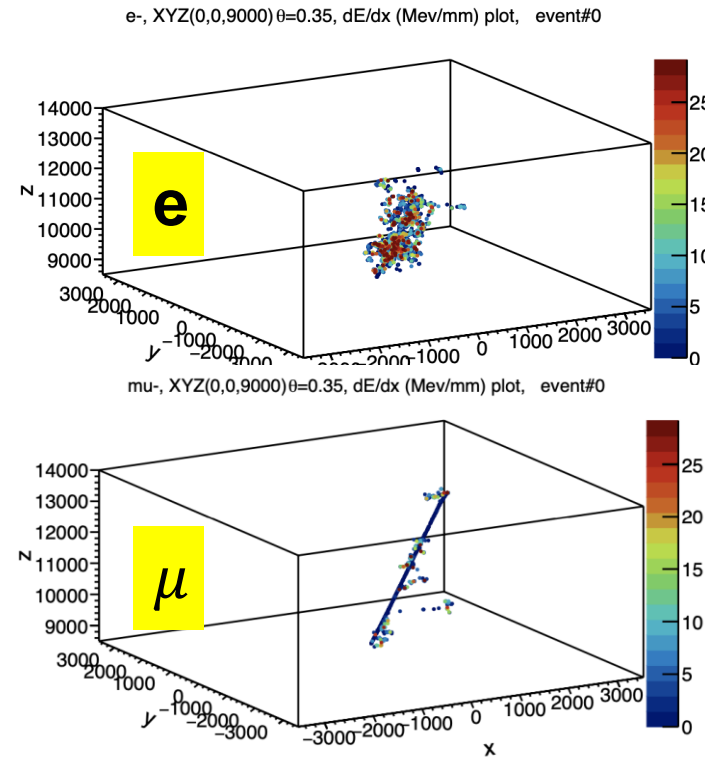
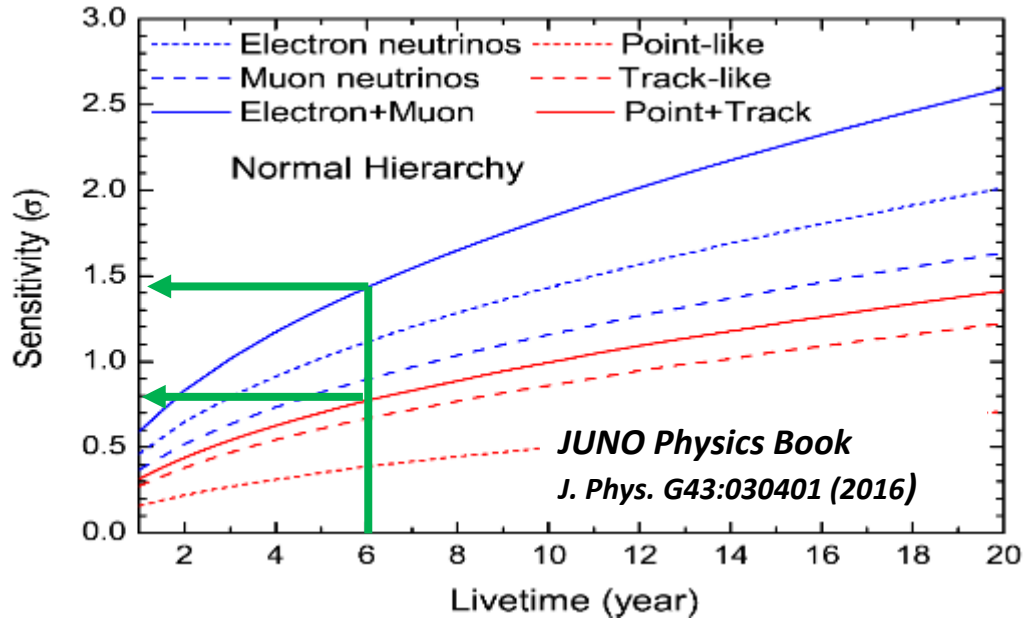

- NMO sensitivity: $0.8\sim 1.4\sigma$ @ 6 years with atm ν only
- Significant progress on event reconstruction and selection methods
- Full chain atmospheric analysis is ongoing and combination with reactor antineutrinos is expected

Precision Oscillation Measurement



About one order of magnitude improvements in precision

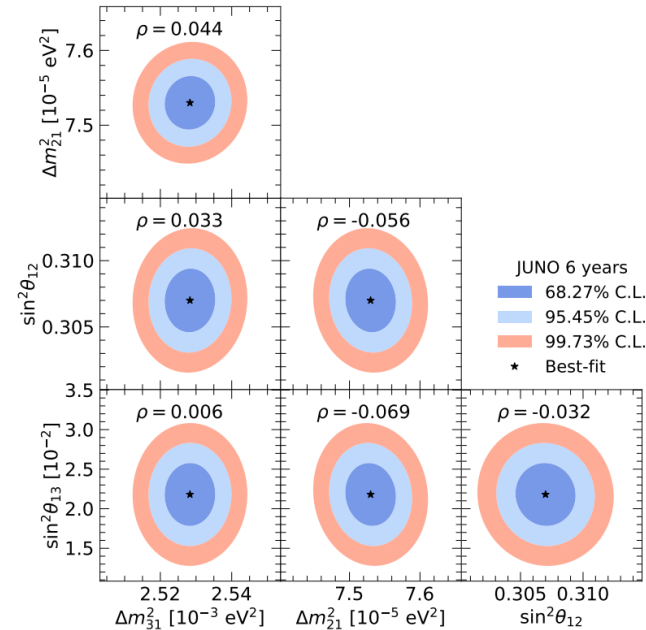
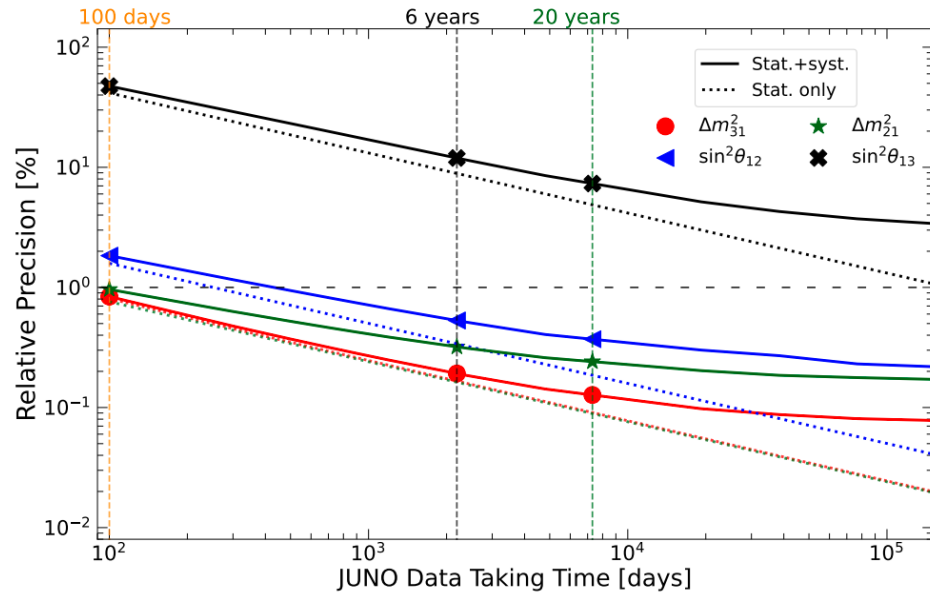

Much better than that of the quark sector even through we had (b,c,s) factories

	Central Value	PDG2020	100 days	6 years	20 years
Δm_{31}^2 ($\times 10^{-3}$ eV ²)	2.5283	± 0.034 (1.3%)	± 0.021 (0.8%)	± 0.0047 (0.2%)	± 0.0029 (0.1%)
Δm_{21}^2 ($\times 10^{-5}$ eV ²)	7.53	± 0.18 (2.4%)	± 0.074 (1.0%)	± 0.024 (0.3%)	± 0.017 (0.2%)
$\sin^2 \theta_{12}$	0.307	± 0.013 (4.2%)	± 0.0058 (1.9%)	± 0.0016 (0.5%)	± 0.0010 (0.3%)
$\sin^2 \theta_{13}$	0.0218	± 0.0007 (3.2%)	± 0.010 (47.9%)	± 0.0026 (12.1%)	± 0.0016 (7.3%)

Precision of $\sin^2 2\theta_{12}$, Δm_{21}^2 , $|\Delta m_{32}^2| < 0.5\%$ in 6 years

Supernovae neutrinos



SN neutrinos of 30 M_{\odot} Nakazato model

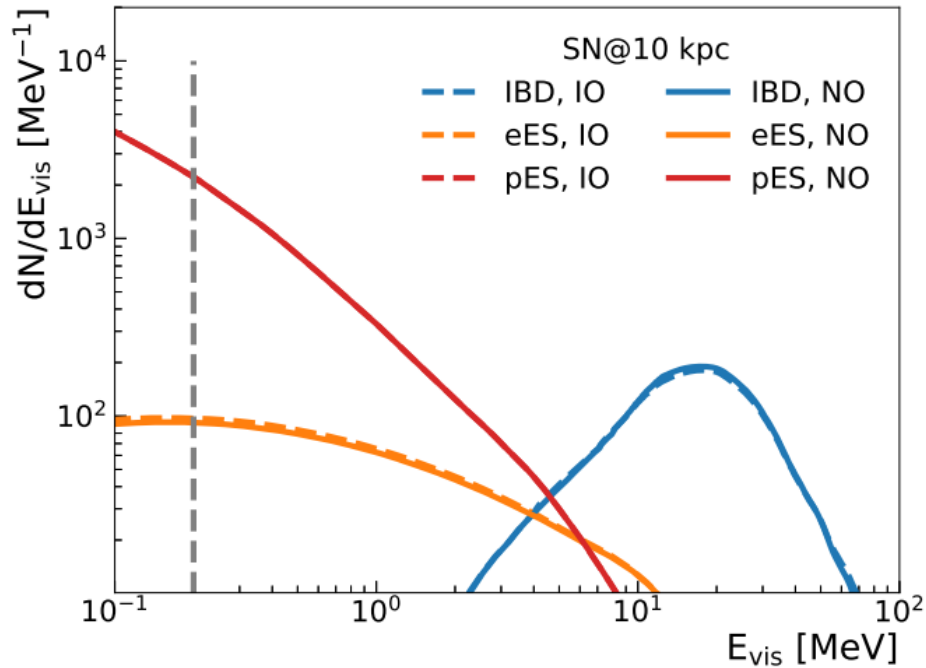

JCAP 01 (2024) 057

- 3 detection channels sensitive to all flavors
- Excellent capability for early warning
- 220~400 kpc with 50% probability
- 10 ~ 30 ms for typical 10 kpc

Diffuse supernova neutrino background

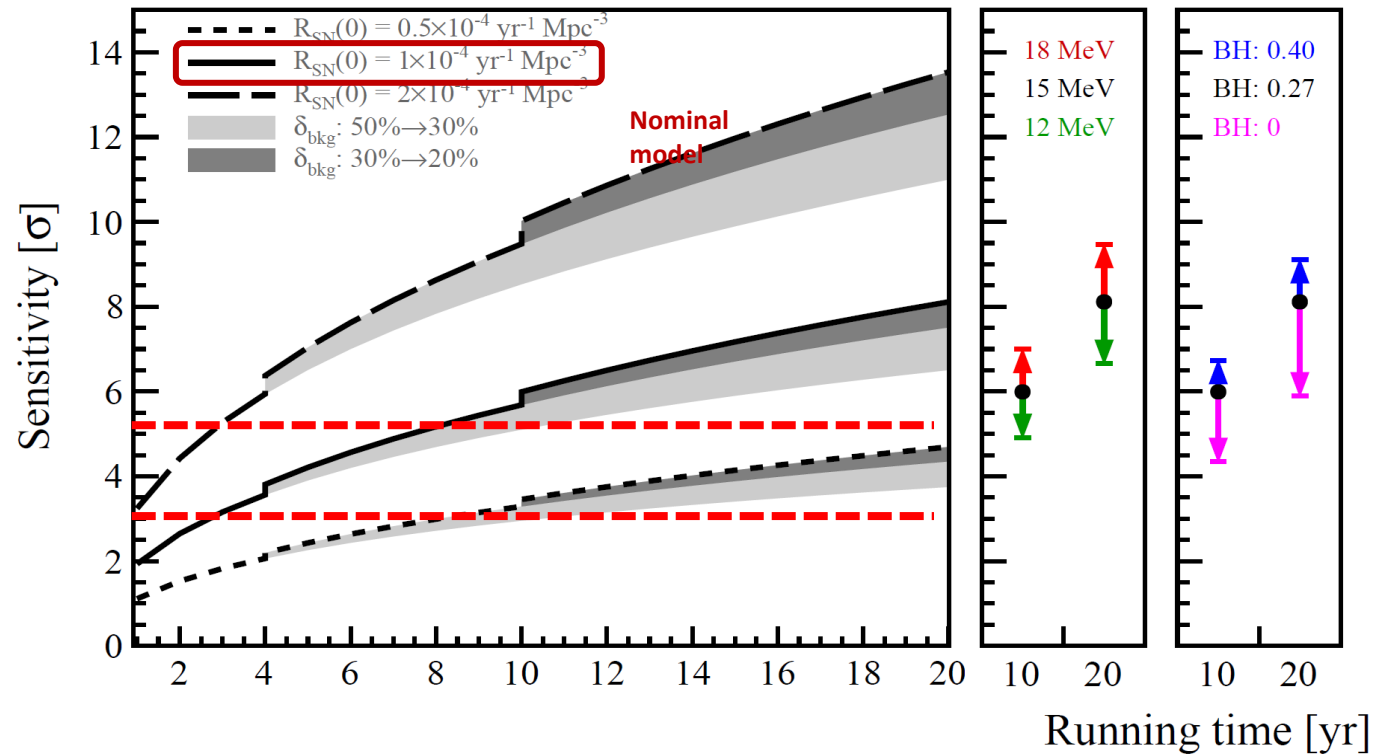

JCAP 10 (2022) 033

- S/B ratio improved from 2 to 3.5
- Using the reference model
- 3σ in 3 years and $>5\sigma$ in 10 years

Solar and Terrestrial Neutrinos



Measure θ_{12} by reactor and solar neutrinos to resolve the tension

^8B measurement
(in NC + CC + ES channels)

Expected precision:

^8B 5% (3% with SNO)
 $\sin^2\theta_{12}$ 8%
 Δm^2_{21} 20%

[arXiv:2210:08437]

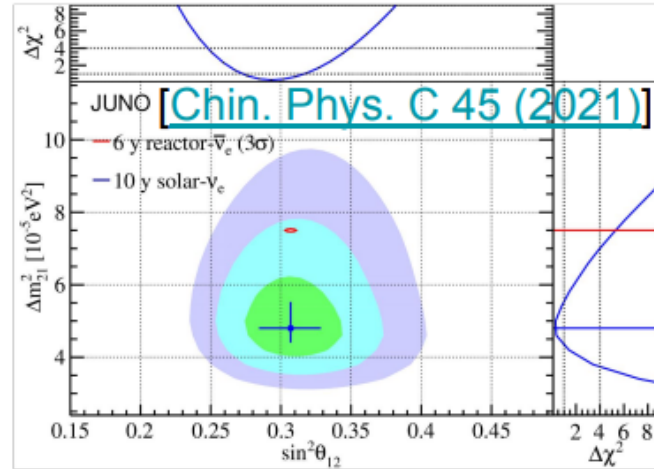

Improve CNO and other solar neutrino measurement over Borexino

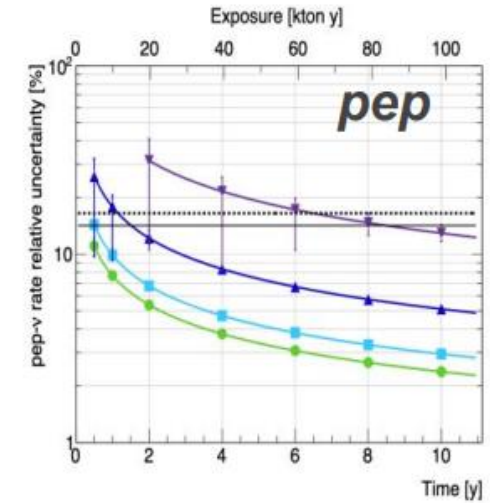
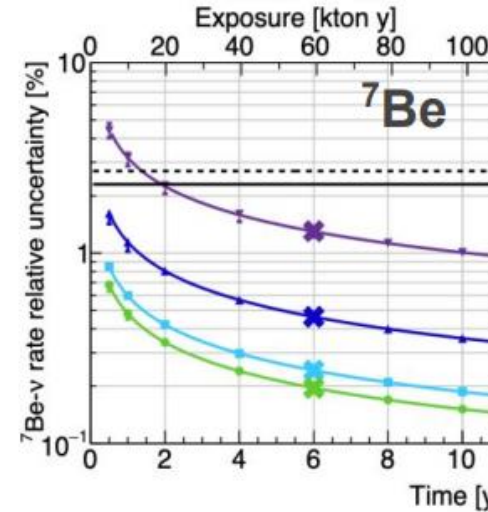

- JUNO will collect the largest dataset of **geoneutrinos** with a precision of Th/U ratio **~8% in 10 years**
- In comparison, KamLAND ~15%, Borexino ~17%

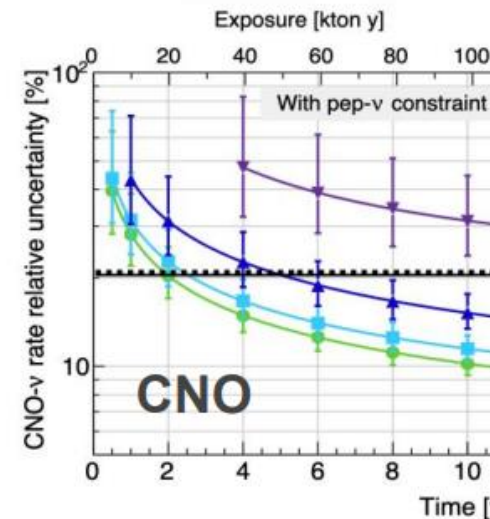
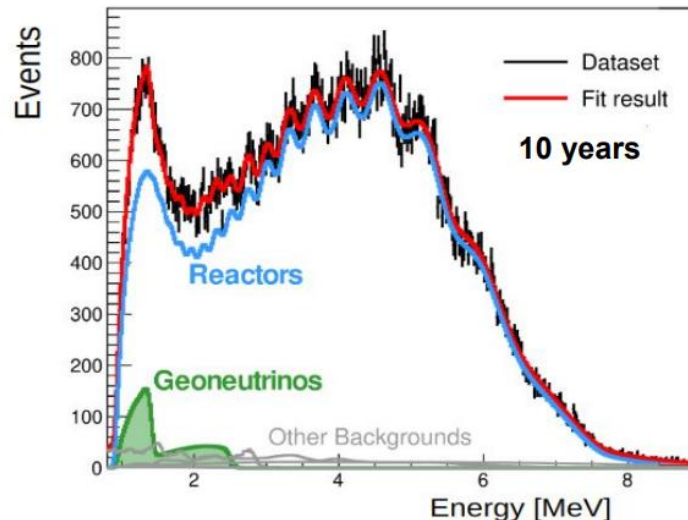

JUNO @ different radio-purity scenarios:

- min. requirement for NMO
- 10 x Borexino Phase-I
- Borexino Phase-I
- Borexino Phase-III (U/Th 10^{-17} g/g)

... Borexino result

[arXiv:2303.03910, accepted by JCAP]

Nucleon Decays

Target mass: 20 kton LS \rightarrow 1.45×10^{33} free protons, 5.30×10^{33} bound protons/neutrons

$p \rightarrow \bar{\nu} K^+$ Triple coincidence

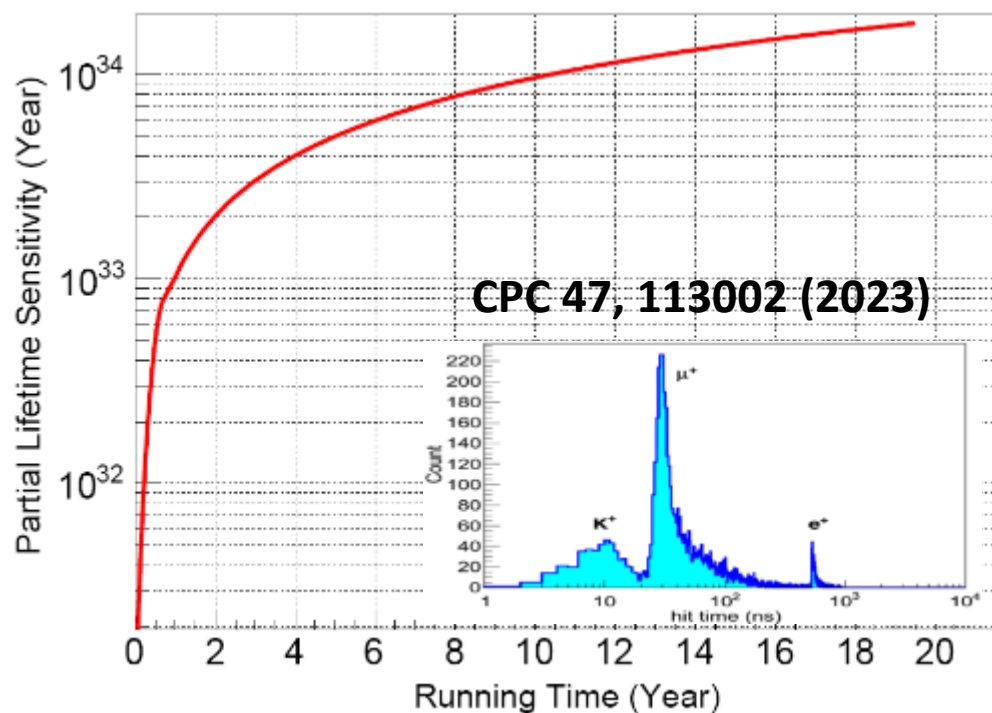

$\tau/B(p \rightarrow \bar{\nu} K^+) > 9.6 \times 10^{33}$ yrs/10 yrs
 Best limit: 5.9×10^{33} yrs from Super-K

Neutron invisible decays

- $n \rightarrow inv$ ($^{12}\text{C} \rightarrow ^{11}\text{C}^*$)
- $nn \rightarrow inv$ ($^{12}\text{C} \rightarrow ^{10}\text{C}^*$)

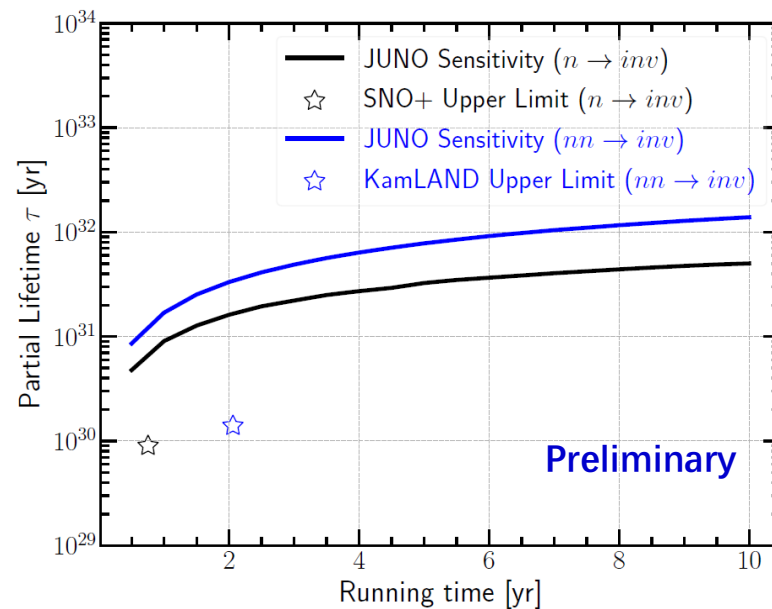

An order of magnitude improvement to the current best limits in 2 years data taking

JUNO- $\beta\beta$



- In ten years from now, oscillation parameters will all be measured
- $0\nu\beta\beta$ decay will be the next focus:

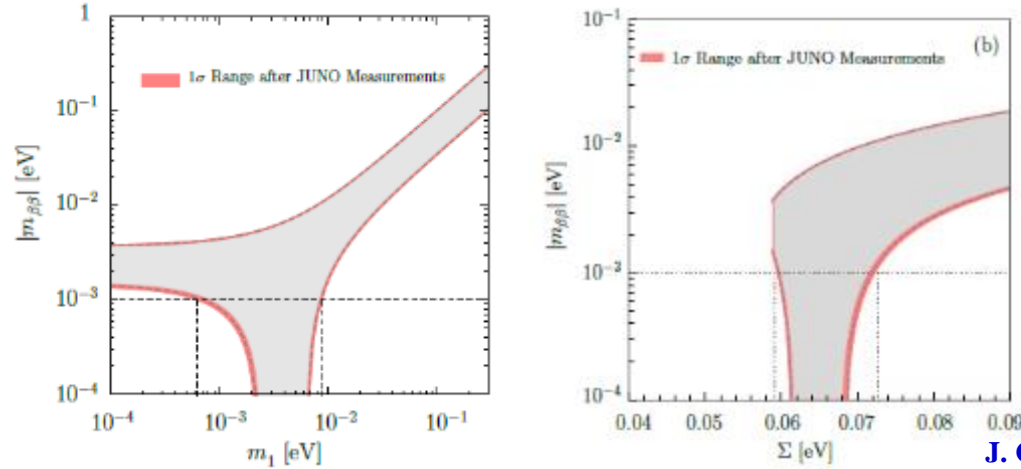

J. Cao et al., arXiv:1908.08355

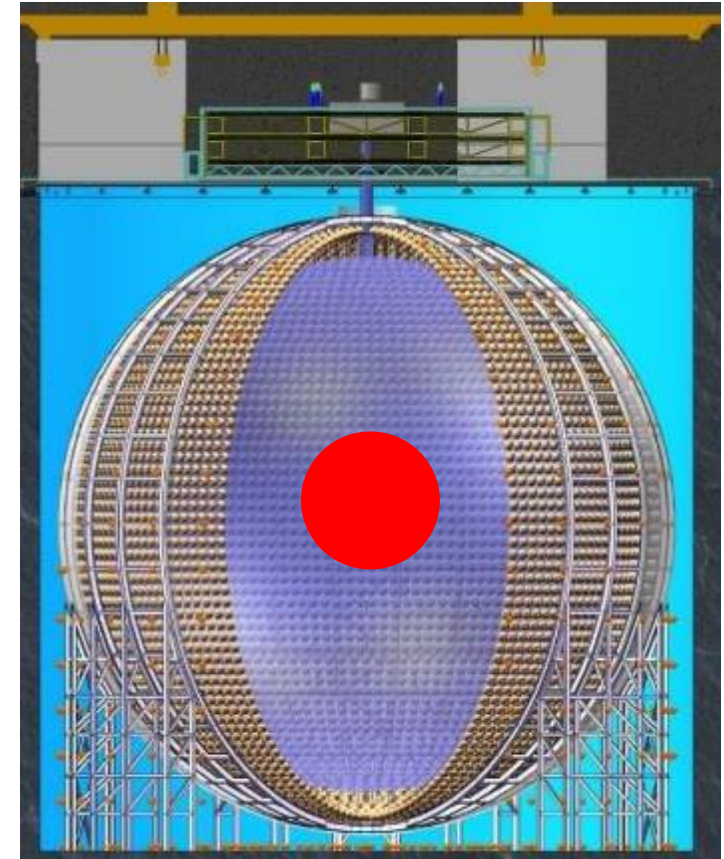

Insert a balloon filled with ^{136}Xe -loaded LS (or ^{130}Te) into the JUNO detector

Zhao et al., arXiv: 1610.07143, CPC 41 (2017) 5

	Isotope	Mass(t)	$\langle m_{\beta\beta} \rangle, \text{meV}$
SNO+	^{130}Te	8	19-46
KamLAND2-Zen	^{136}Xe	1	~20
NEXT-HD	^{136}Xe	1	14-40
nEXO	^{136}Xe	5	7-22
Darwin/Panda-nT	^{136}Xe	3-5	7-22
LEGEND-1000/CDEX-1t	^{76}Ge	1	10-40
AMoRE-II	^{100}Mo	0.1	12-22
CUPID	^{100}Mo	0.24	12-20
CUPID-1T	^{100}Mo	1	4-7
JUNO- $\beta\beta$	^{136}Xe	50	4-10
	^{130}Te	100	3-14

- **JUNO construction near completion, overcoming challenges**
- **Component quality exceeding the design value, performance may surpass expectations**
- **Neutrino mass ordering may be known within this decade**
- **Anticipate groundbreaking results in particle and astro-particle physics from JUNO**

