

# From (Particle) Physics to Medical Applications

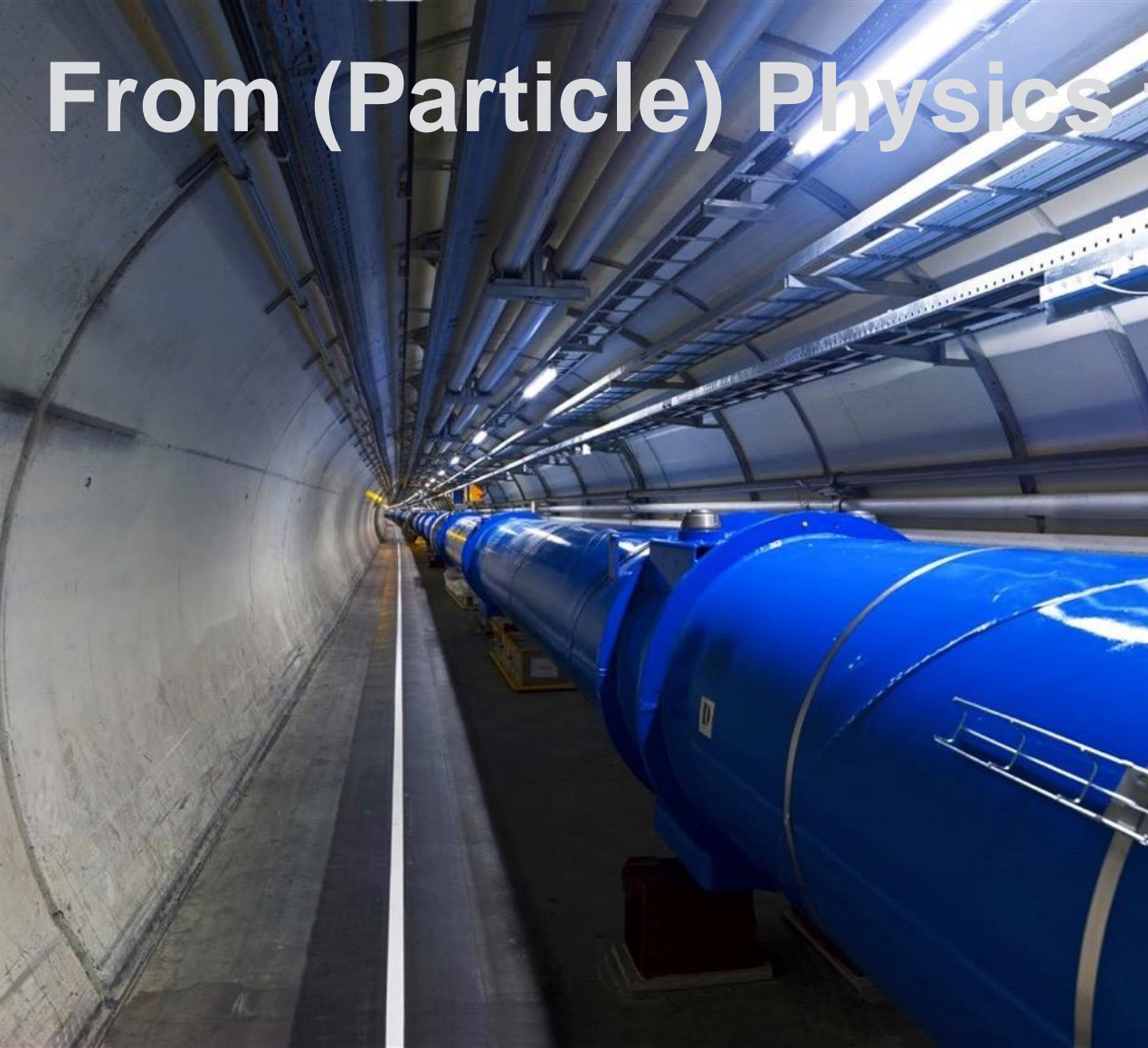


Photo: CNAO treatment room

Manuela Cirilli

Medical Applications Adviser  
CERN Knowledge Transfer group



Knowledge Transfer  
*Accelerating Innovation*

# Disclaimer(s) & Acknowledgments

Of course, I had to select the material to be included.

And of course, Physics  $\neq$  HEP (but a lot of HEP here, and a lot of CERN examples).

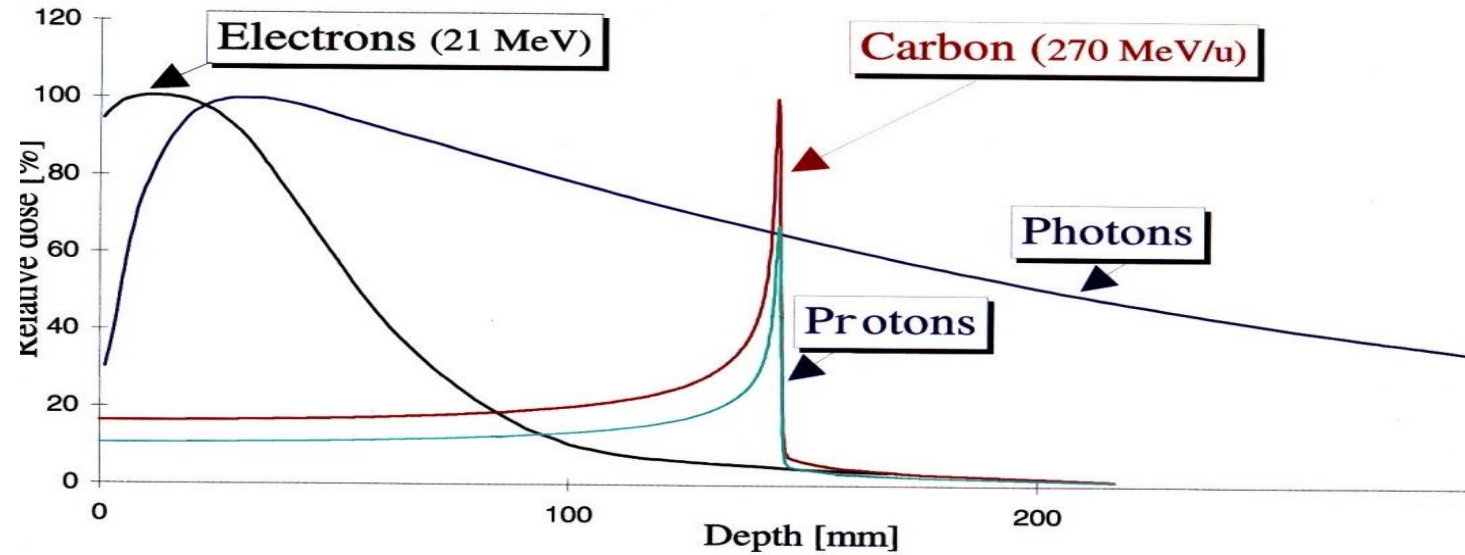
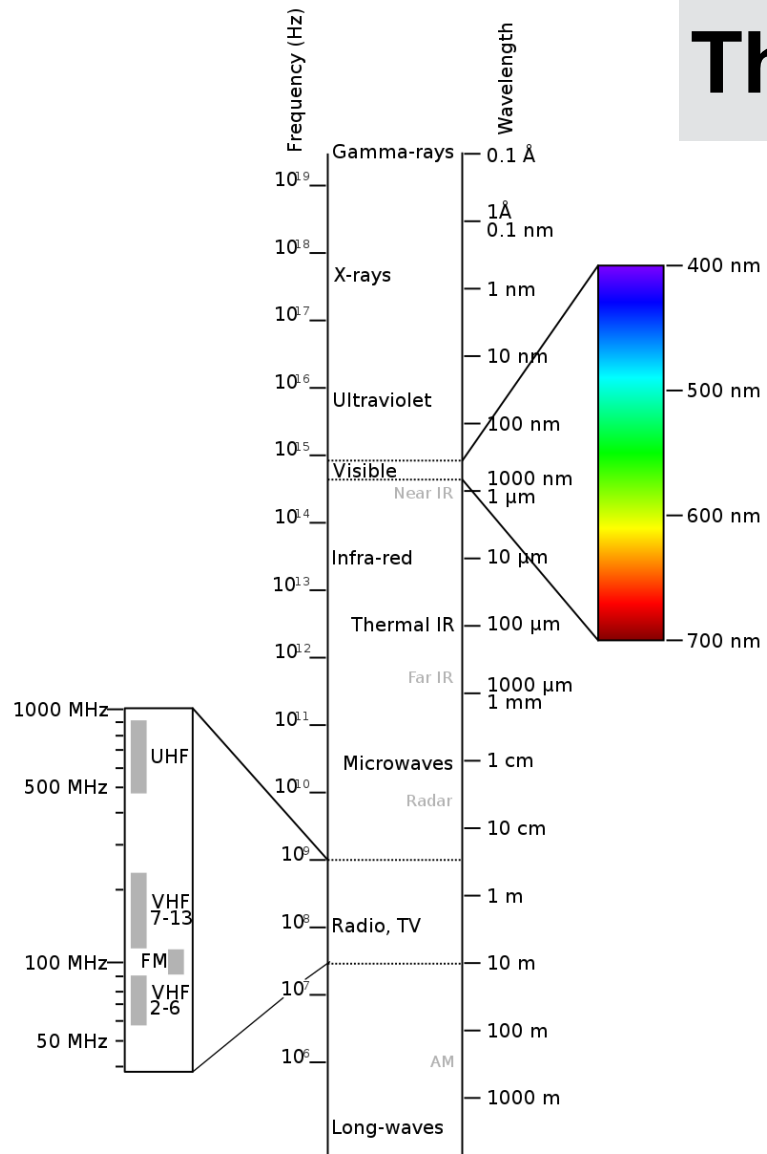
The CERN medical applications-related projects presented in this talk are realized by the CERN scientists and engineers: without their skills, ingenuity, and dedication, there would be no knowledge to transfer! Some names are acknowledged on the respective slides, but there are many more.

The KT group and myself are privileged to have the opportunity to support these projects in a tailored way, and to help bridge the gap between CERN technologies and society.

Many thanks to all the colleagues from CERN, CNAO, CHUV, GSI, MedAustron, INFN, TERA who have shared their material and wisdom with me; thanks to Ugo Amaldi and Manjit Dosanjh, from whom I first learned about hadron therapy.

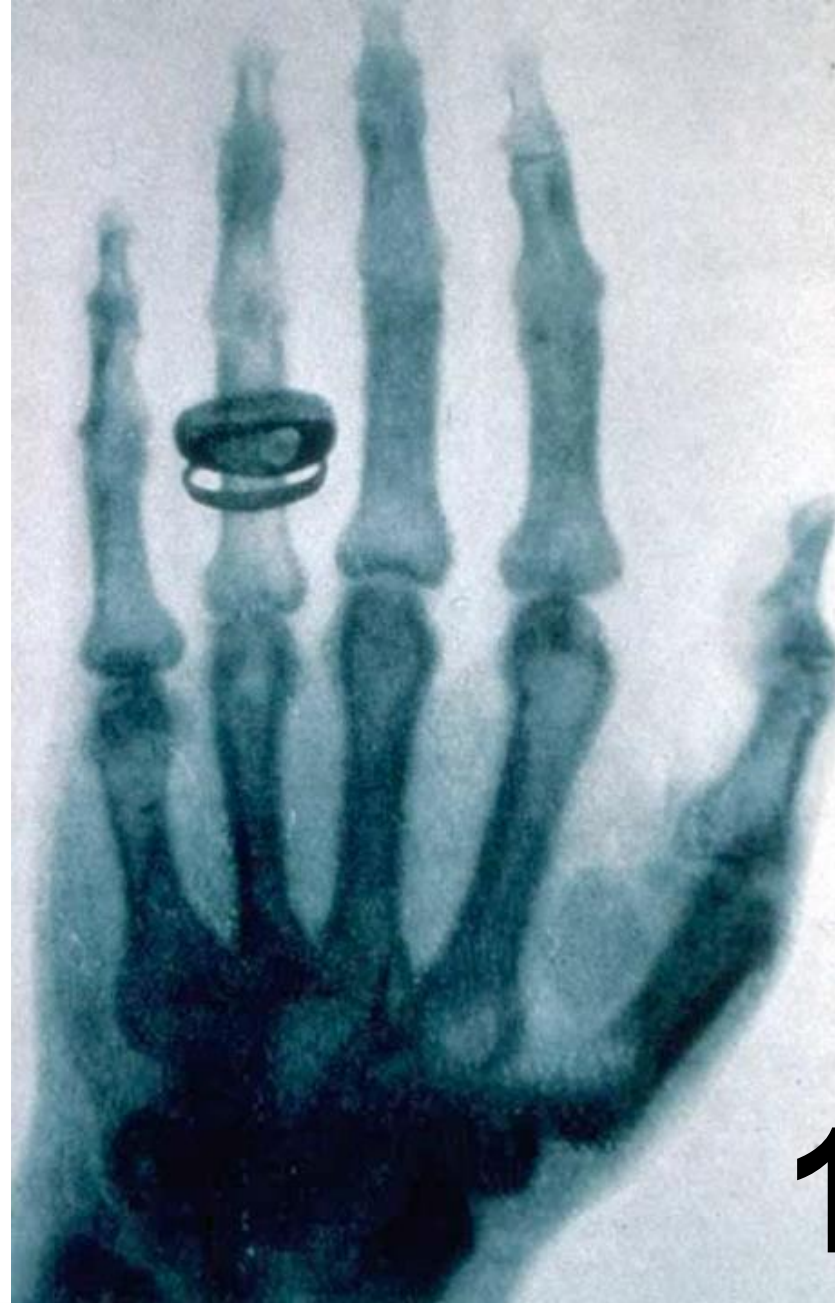
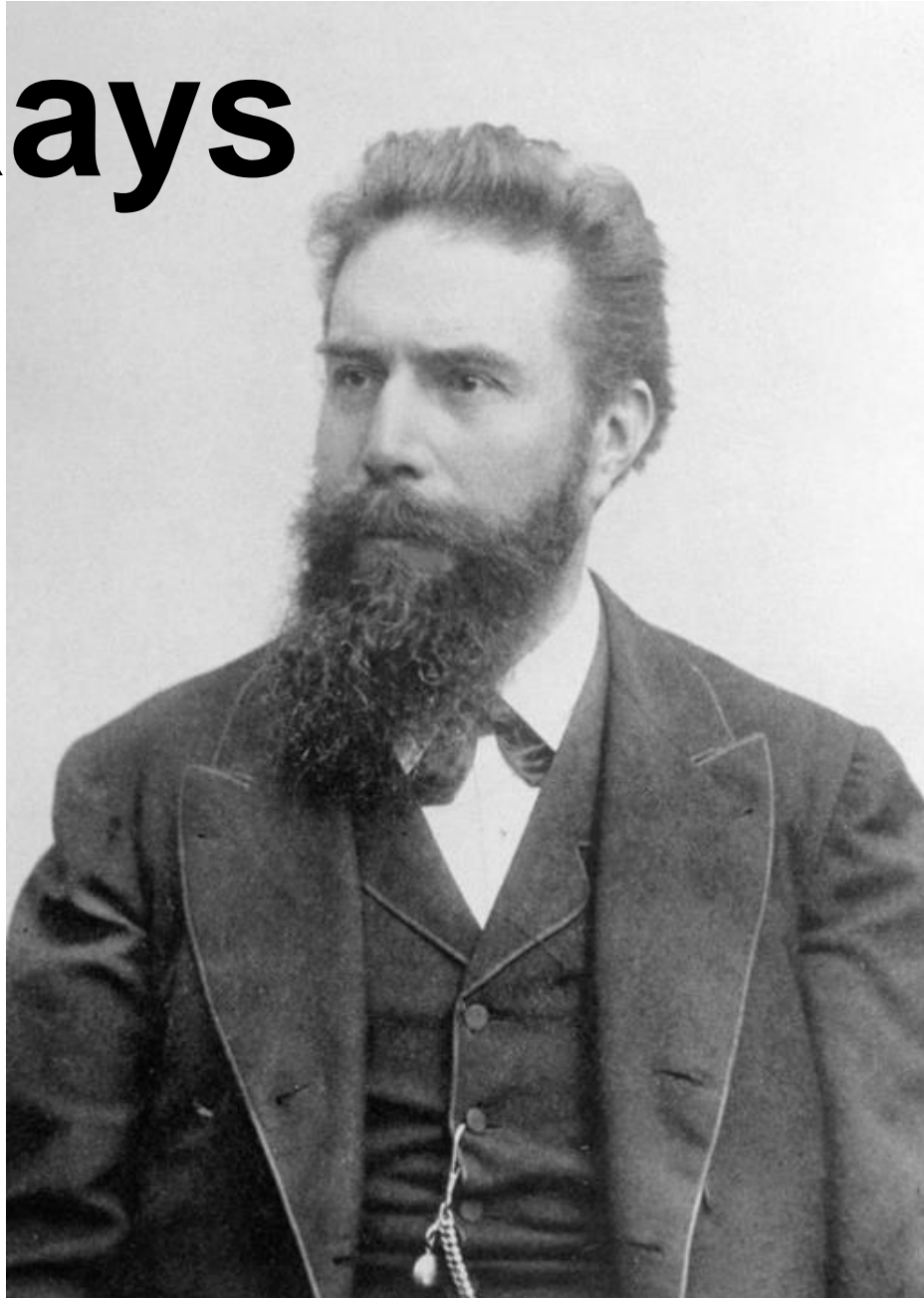
I am neither a doctor, nor a medical physicist, nor a technical expert in most of the technologies I present, so let's see how many of your questions I'm able to answer! 😊

# The physics itself

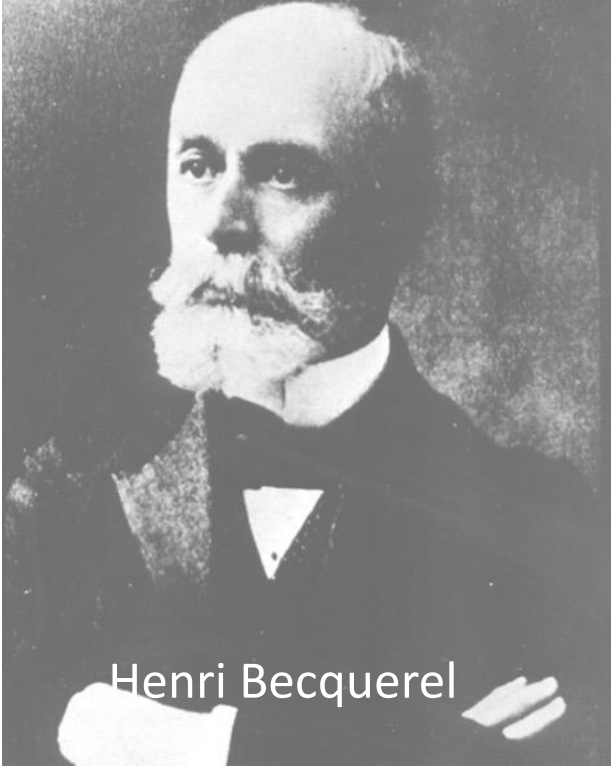


By Original: Penubag Vector: Victor Blacus - Own work based on: Electromagnetic-Spectrum.png, CC BY-SA 3.0, <https://commons.wikimedia.org/w/index.php?curid=22428451>

# X-Rays



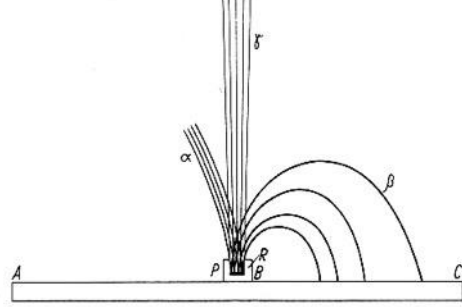
**1895**



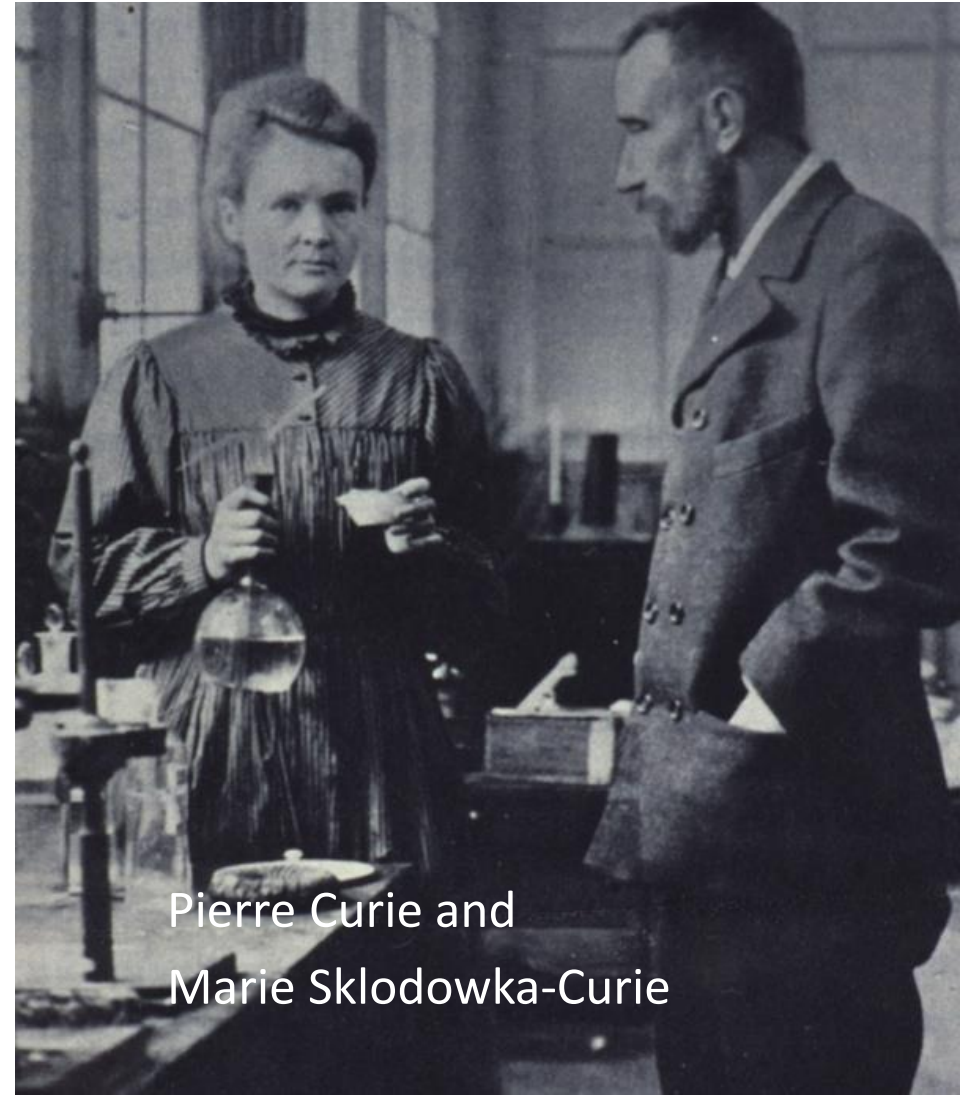
Henri Becquerel

1896: accidental discovery of natural radioactivity

Mme. Curie thesis – 1904  
 $\alpha$ ,  $\beta$ ,  $\gamma$  in magnetic field



1898: by studying the strange uranium rays, they soon discovered polonium, thorium, radium



Pierre Curie and Marie Skłodowka-Curie

CRÈME  
POUDRE

SAVON  
DENTIFRICE

**THO-RADIA**  
à base de Thorium et de radium selon la formule du  
DOCTEUR ALFRED CURIE  
EN VENTE EXCLUSIVEMENT CHEZ LES PHARMACIENS

Par Cinémagazine, 14 février 1935 —  
<https://gallica.bnf.fr/ark:/12148/bpt6k2000628h>, CC BY-SA 4.0,  
<https://commons.wikimedia.org/w/index.php?curid=97956453>

12 New York Tribune November 10, 1918

# Radium and Beauty

**HERE are the first toilet preparations to embody Actual Radium.** An astonishing new force for betterment, applied as an aid to Beauty. Learn how the amazing Energy of Radium has proved a boon to the human skin. Learn what Radium actually means to Beauty and how its power is employed in "Radium" Preparations. Study our \$5,000 guarantee. Then turn to "Radium" Toilet Requisites. When you have used, enjoyed and tested them you will adopt them as your own first aid to Beauty.

**PREHINTIC** women find discovered hair change in some special jangle pool. *Ever since Beauty's* has changed the world's attention.

Radium, though new to the world in its scientific application, its scientific use is not new. It has been known for centuries as a source of energy. It is the source of the energy that makes the sun shine and the stars burn. It is the source of the energy that makes the earth warm and the life of the world possible.

It is the source of the energy that makes the human body warm and the life of the world possible. It is the source of the energy that makes the human body warm and the life of the world possible.

**Radium Toilet Requisites**

"Radium" Toilet Requisites are remarkably lighter in price. This is due to the quantity of Actual Radium. But the greater benefit obtained from "Radium" Preparations would justify an even higher price. The best is always the cheapest and goes further.

If it is your purpose to purchase "Radium" Preparations, try them. You have already the Vending Counter.

Each and every "Radium" Beauty Aid is the result of a famous French specialist, Dr. Alfred Curie, who has spent the last thirty years of his life in the study of the scientific use of radium. He has discovered the scientific use of radium in the treatment of the human body.

When you use "Radium" Beauty Aids, you are using the scientific use of radium. You are using the scientific use of radium. You are using the scientific use of radium.

Write Today for This Vitrally Interesting Booklet

This is probably the most interesting booklet on the subject of Beauty ever published. It has been written by the man who has discovered the scientific use of radium. It is a booklet which will tell you all you need to know about radium and its use in the treatment of the human body.

**RADIUM TOILET REQUISITES OBTAINABLE AT**  
 Leading Department Stores of  
 New York, Brooklyn and Newark  
 Liggett's Drug Stores

**Radium Co., Ltd., of London**  
 235 Fifth Avenue, New York 187 Oxford St., London, W. 1.  
 If your Dealer cannot supply you communicate with us.

Par Radium cosmetics — sited New York Tribune Magazine, page 12, Domaine public,  
<https://commons.wikimedia.org/w/index.php?curid=35047170>



Par Sam LaRussa from United States of America —  
 Radithor, CC BY-SA 2.0,  
<https://commons.wikimedia.org/w/index.php?curid=57841049>

**X-RAY**

**FITTING**

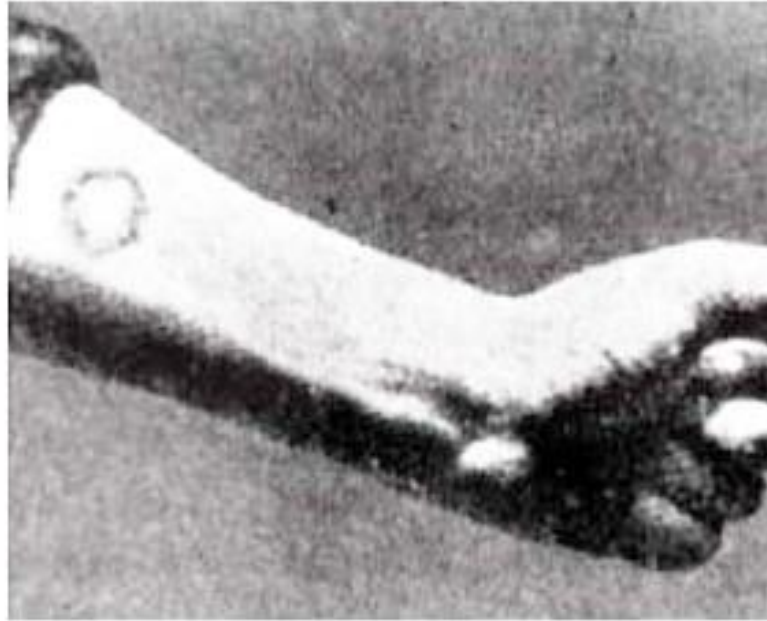
**CUSTOMERS**

**EXPECT IT!**

<https://www.smh.com.au/national/nsw/from-the-archives-1956-ban-urged-of-x-ray-machines-at-shoe-shops-20210318-p57c1m.html>



Friedrich Giesel  
1852-1927



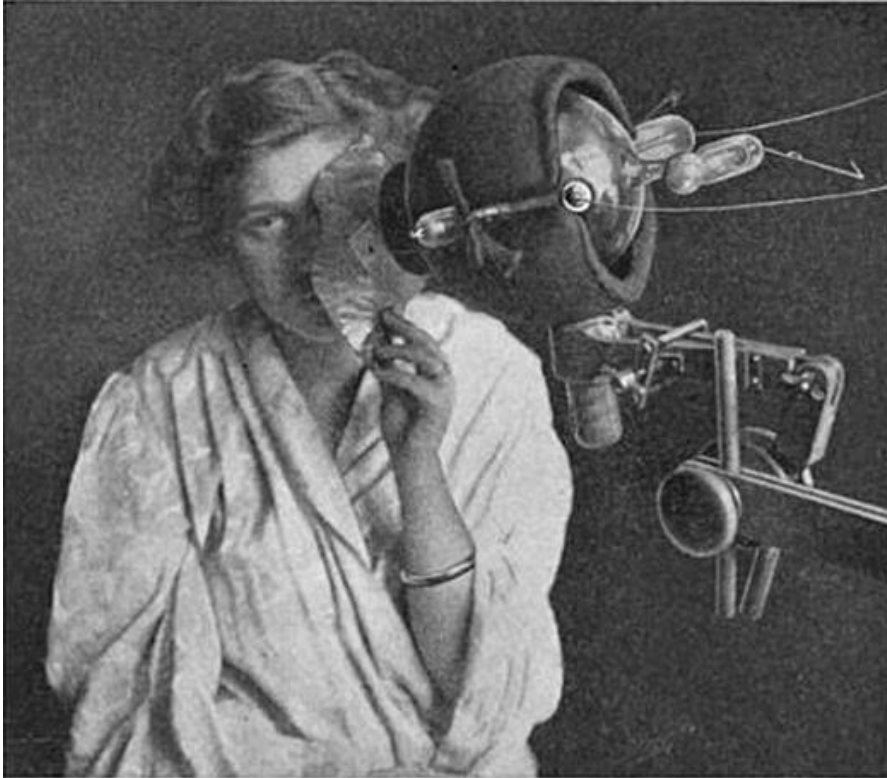
Burning of Pierre Curie's arm



Pierre Curie  
1859-1906

Photo of Pierre Curie's arm, burned by radium salt applied for 10 hours. In 1900, the German dentist Walkhoff noted that radium rays act energetically on the skin in a manner analogous to that of X-rays. This observation was confirmed a few weeks later by the German chemist F. Giesel, with whom Pierre and Marie maintained regular correspondence.

© CNRS Audiovisuel ©



X-ray apparatus used for treatment of epithelioma of the face, 1915.



Small tubes containing radium salts are strapped to a woman's face to treat what was either lupus or rodent ulcer, 1905.



## The Nobel Prize in Physics 1944



Photo from the Nobel Foundation archive.

**Isidor Isaac Rabi**

Prize share: 1/1

The Nobel Prize in Physics 1944 was awarded to Isidor Isaac Rabi "for his resonance method for recording the magnetic properties of atomic nuclei."

## The Nobel Prize in Physics 1952



Photo from the Nobel Foundation archive.

**Felix Bloch**

Prize share: 1/2



Photo from the Nobel Foundation archive.

**Edward Mills Purcell**

Prize share: 1/2

The Nobel Prize in Physics 1952 was awarded jointly to Felix Bloch and Edward Mills Purcell "for their development of new methods for nuclear magnetic precision measurements and discoveries in connection therewith."

## The Nobel Prize in Physiology or Medicine 2003



Photo from the Nobel Foundation archive.

**Paul C. Lauterbur**

Prize share: 1/2



Photo from the Nobel Foundation archive.

**Sir Peter Mansfield**

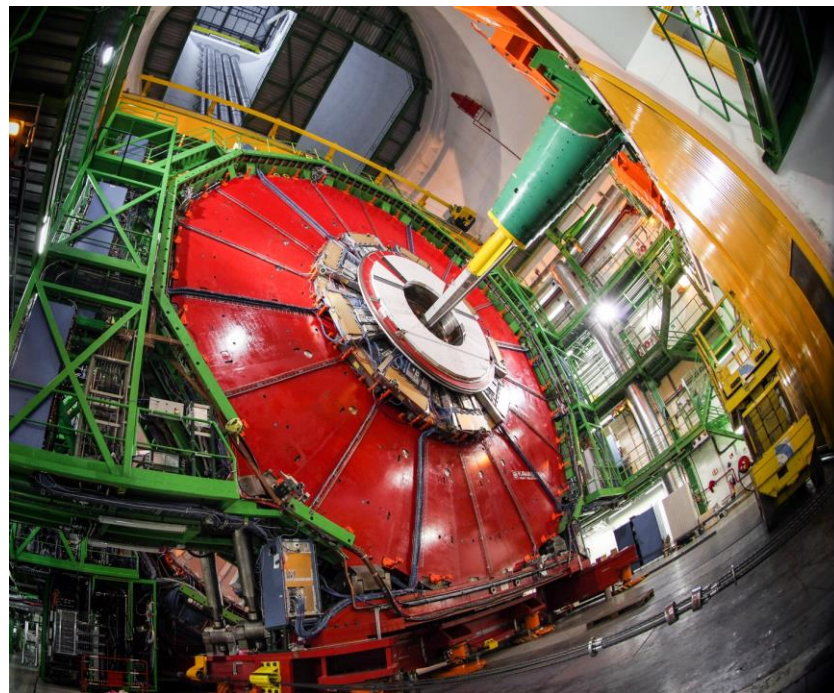
Prize share: 1/2

The Nobel Prize in Physiology or Medicine 2003 was awarded jointly to Paul C. Lauterbur and Sir Peter Mansfield "for their discoveries concerning magnetic resonance imaging."

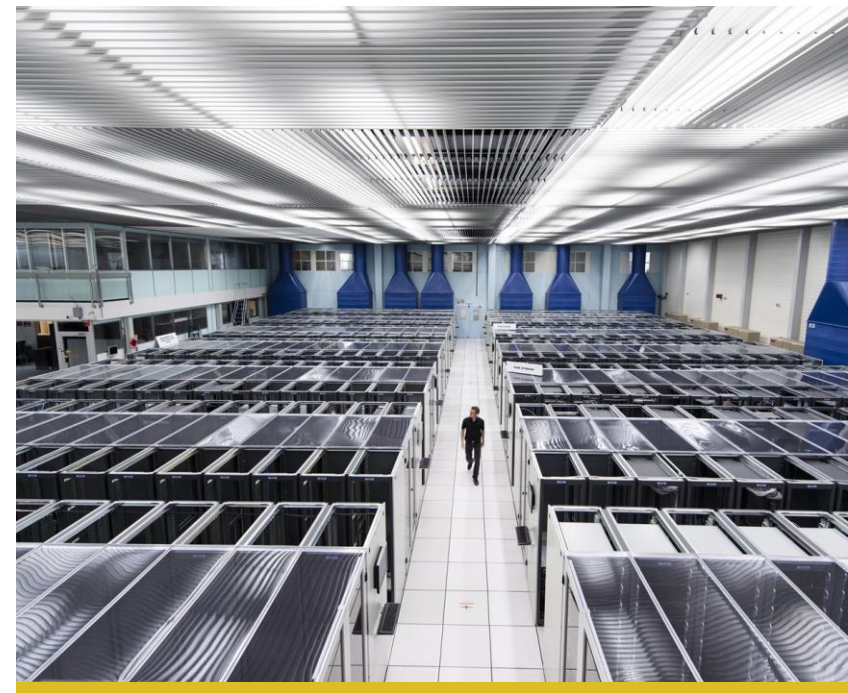
# The technologies



ACCELERATORS

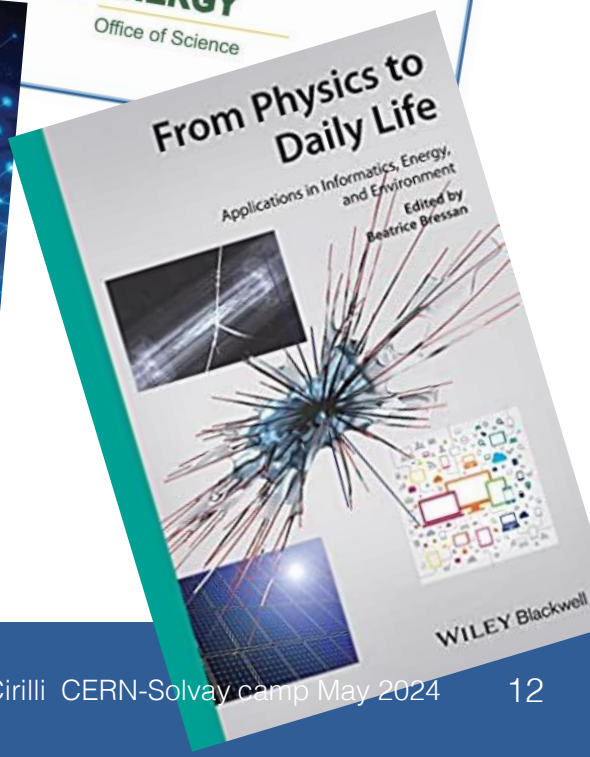
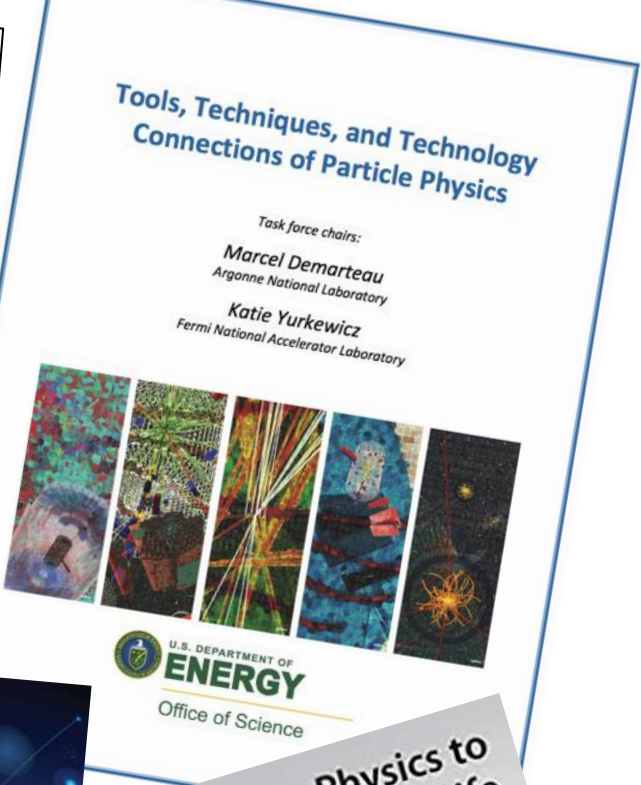


DETECTORS



COMPUTING

sound reproduction  
data management  
astronauts' radiation exposure  
testing satellite components  
understanding turbulence  
medical implants  
food sterilization  
homeland security  
finding oil, gas, water  
scientific linux  
spacecraft shielding  
geological dating  
curing of epoxies and plastics  
x-ray diffractometry  
radiology  
medical equipment sterilization  
medical radioisotopes  
non-destructive testing  
ion implantation  
shrink wrap  
radiotherapy  
rad-hard electronics  
simulations  
PET  
terrestrial reproduction of space radiation  
industry 4.0  
digital data preservation  
nuclear waste transmutation  
optimised irrigation systems  
open hardware  
WWW  
treatment planning systems  
drug development  
powering complex biological simulations  
safety  
analysis of satellite data  
volcano tomography  
space applications  
sealing food packages  
autonomous vehicles  
isotope production  
smoke detectors  
hadron therapy  
cultural heritage  
MRI  
cleaner air and water  
ink curing  
cargo screening  
computer chips manufacturing  
studying the retina  
medical dosimetry  
material science



Over 70 companies and institutes produce accelerators for industrial applications; these organizations sell more than **1,100 industrial systems per year** — almost twice the number produced for research or medical therapy — at a **market value of \$2.2B.**

Over **\$1B** of this amount is generated by the sales of accelerators for **ion implantation** into materials — primarily semiconductor devices — whose worldwide value of production is about \$300B.

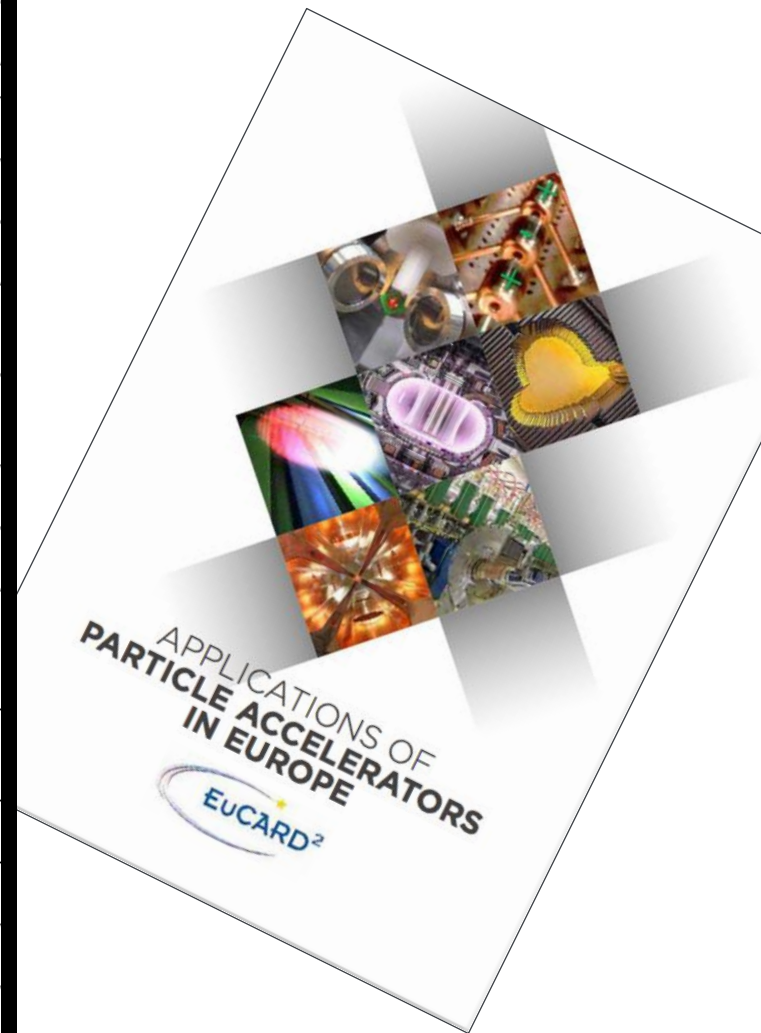
Hamm, R. and Hamm, M. (2012). Industrial accelerators and their applications. World Scientific Publishing Co.

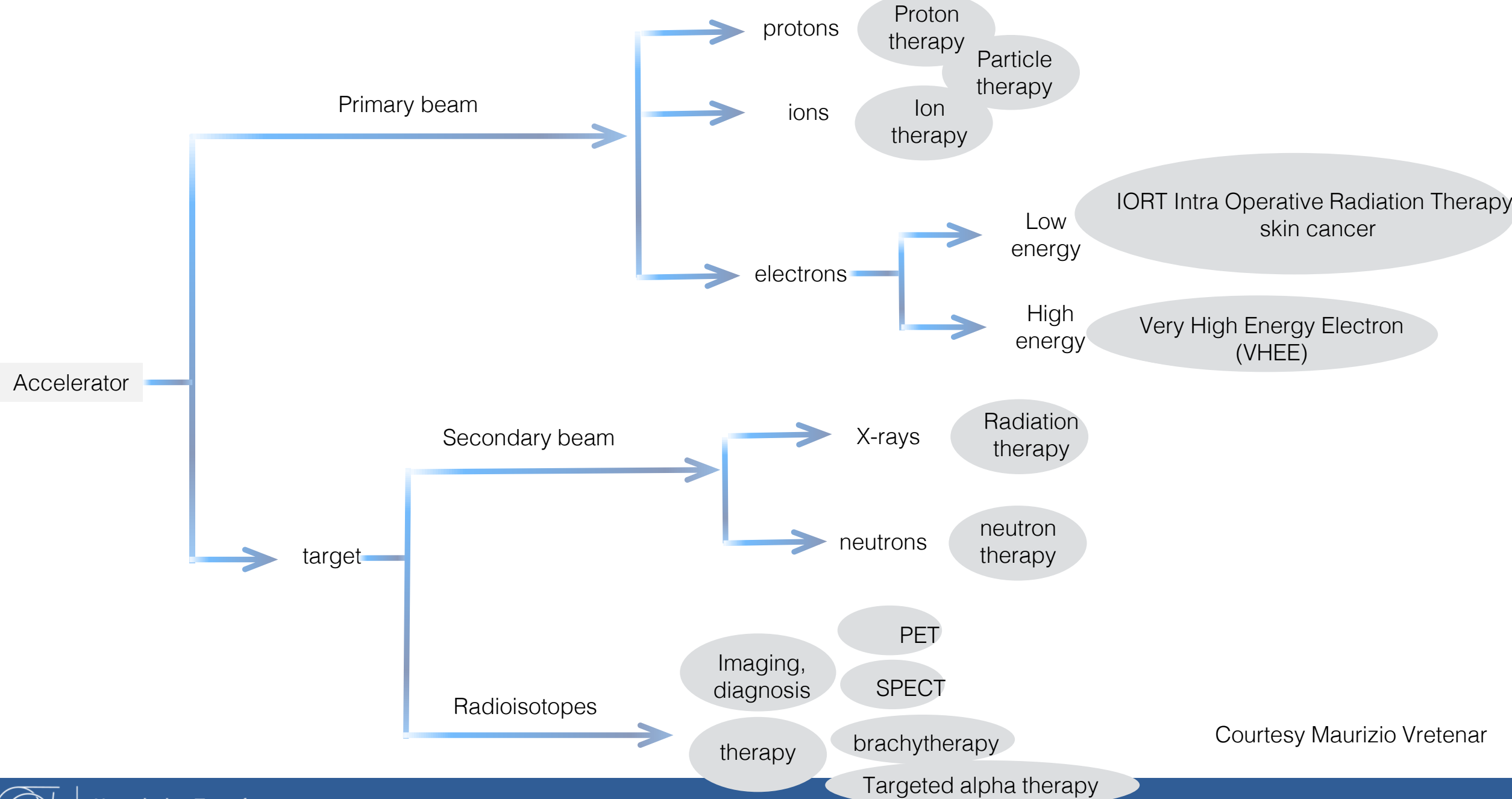
As of 2014 there were **42,200** accelerators worldwide:  
**27,000 (64%)** in industry,  
**14,000 (33%)** for medical purposes  
**1,200 (3%)** for basic research.

These figures exclude electron microscopes and x-ray tubes, and the security and defense industries.

Chernyaev, A. P. and Varzar, S. M. (2014). Particle accelerators in modern world. *Physics of Atomic Nuclei*, 77(10):1203–1215.

Area	Application	Beam	Accelerator	Beam energy/MeV	Beam current/ mA	Number
<b>Medical</b>	Cancer therapy	e	linac	4-20	$10^{-2}$	>14000
		p	cyclotron, synchrotron	250	$10^{-6}$	60
		C	synchrotron	4800	$10^{-7}$	10
	Radioisotope production	p	cyclotron	8-100	1	1600
<b>Industrial</b>	Ion implantation	B, As, P	electrostatic	< 1	2	>11000
	Ion beam analysis	p, He	electrostatic	<5	$10^{-4}$	300
	Material processing	e	electrostatic, linac, Rhodatron	$\leq 10$	150	7500
	Sterilisation	e	electrostatic, linac, Rhodatron	$\leq 10$	10	3000
<b>Security</b>	X-ray screening of cargo	e	linac	4-10	?	100?
	Hydrodynamic testing	e	linear induction	10-20	1000	5
<b>Synchrotron light sources</b>	Biology, medicine, materials science	e	synchrotron, linac	500-10000		70
<b>Neutron scattering</b>	Materials science	p	cyclotron, synchrotron, linac	600-1000	2	4
<b>Energy - fusion</b>	Neutral ion beam heating	d	electrostatic	1	50	10
	Heavy ion inertial fusion	Pb, Cs	Induction linac	8	1000	Under development
	Materials studies	d	linac	40	125	Under development
<b>Energy - fission</b>	Waste burner	p	linac	600-1000	10	Under development
	Thorium fuel amplifier	p	linac	600-1000	10	Under development
<b>Energy - bio-fuel</b>	Bio-fuel production	e	electrostatic	5	10	Under development
<b>Environmental</b>	Water treatment	e	electrostatic	5	10	5
	Flue gas treatment	e	electrostatic	0.7	50	Under development





Courtesy Maurizio Vretenar

# Radiotherapy





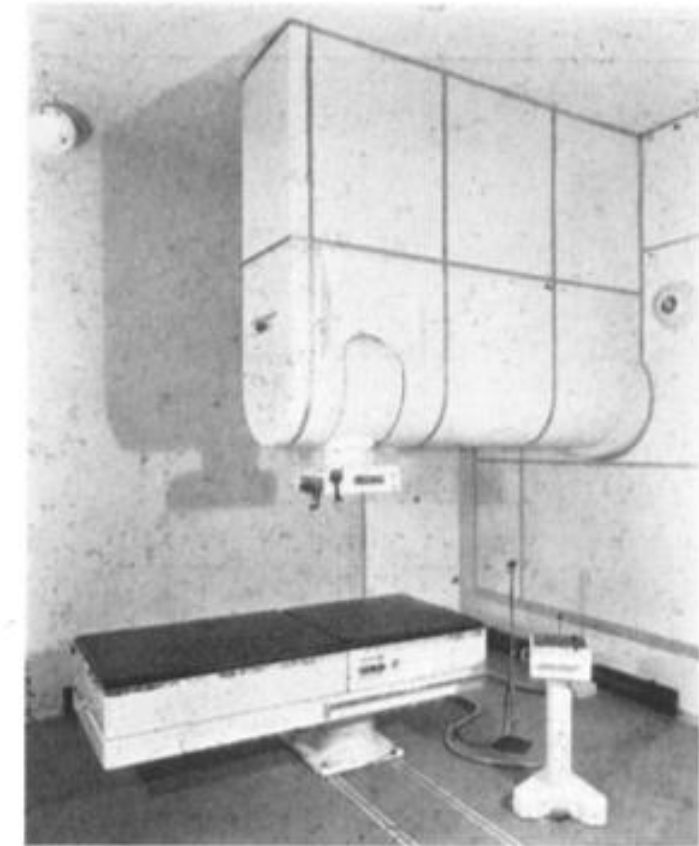
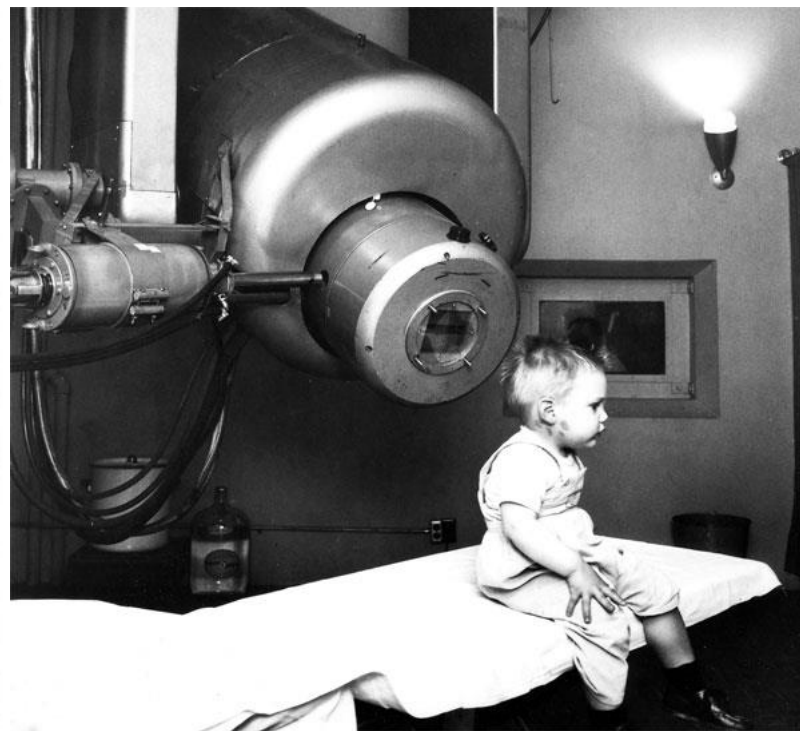


Fig. 1. The 8 MeV linear accelerator (Metropolitan-Vickers) at Hammersmith Hospital with the angle of the roentgen head adjusted to give a beam directed vertically downwards.

1953

P. Howard-Flanders (1954) The Development of the Linear Accelerator as a Clinical Instrument, *Acta Radiologica*, 41:sup116, 649-655, DOI: 10.3109/00016925409177244



1956: The first patient to receive radiation therapy from the medical linear accelerator at Stanford was a 2-year-old boy.

Approx. date of introduction	Model and location	Manufacturer	Beam energy and modality
1953	Hammersmith Hospital, London	Metropolitan-Vickers	8 MV X-rays
1954	St. Bartholomew's Hospital, London	Mullard	15 MeV X-rays and electrons
1954	Christie Hospital, Manchester	Metropolitan-Vickers AEI	4 MV X-rays
1954	Newcastle	Mullard	4 MV X-rays
1955	Stanford	Stanford	5 MV X-rays
1955	Argonne Cancer Hospital, Chicago	Stanford, HVE and Argonne	5-50 MeV electrons
1955	Michael Reese Hospital, Chicago	Stanford, M. Reese and Helene Curtis	45 MeV electrons
1962	Newcastle	Vickers Research	4 MV X-rays
1962	Clinac 6	Varian	6 MV X-rays
1965	Mevatron 8	Applied Radiation	6-8 MV X-rays 3-10 MeV electrons
1965	SL-75	Mullard	6-8 MV X-rays 8-10 MeV electrons

Table 1 (cont.)

Approx. date of introduction	Model and location	Manufacturer	Beam energy and modality
1967	Sagittaire, Paris	CSF	16 MV X-rays 12-32 MeV electrons
1968	Clinac 4	Varian	4 MV X-rays
1969	Mevatron VI & XII	Applied Radiation	6 or 8 MV X-rays 3-11 MeV electrons
1969	LMR-13	Toshiba	8 and 10 MV X-rays 8-13 MeV electrons
1970	Therapi 4	SHM	4 MV X-rays
1970	Clinac 35 Hiroshima	Varian	8 and 25 MV X-rays 7-28 MeV

C J Kartzmark and N C Pering 1973 *Phys. Med. Biol.* **18** 321

# Status of Radiation Therapy Equipment

156

Countries

7687

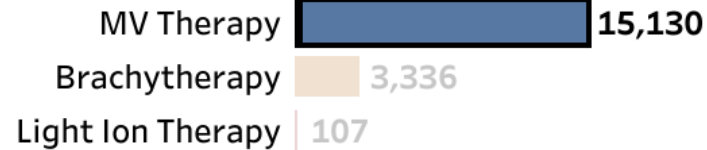
RT Centres

15130

MV Therapy

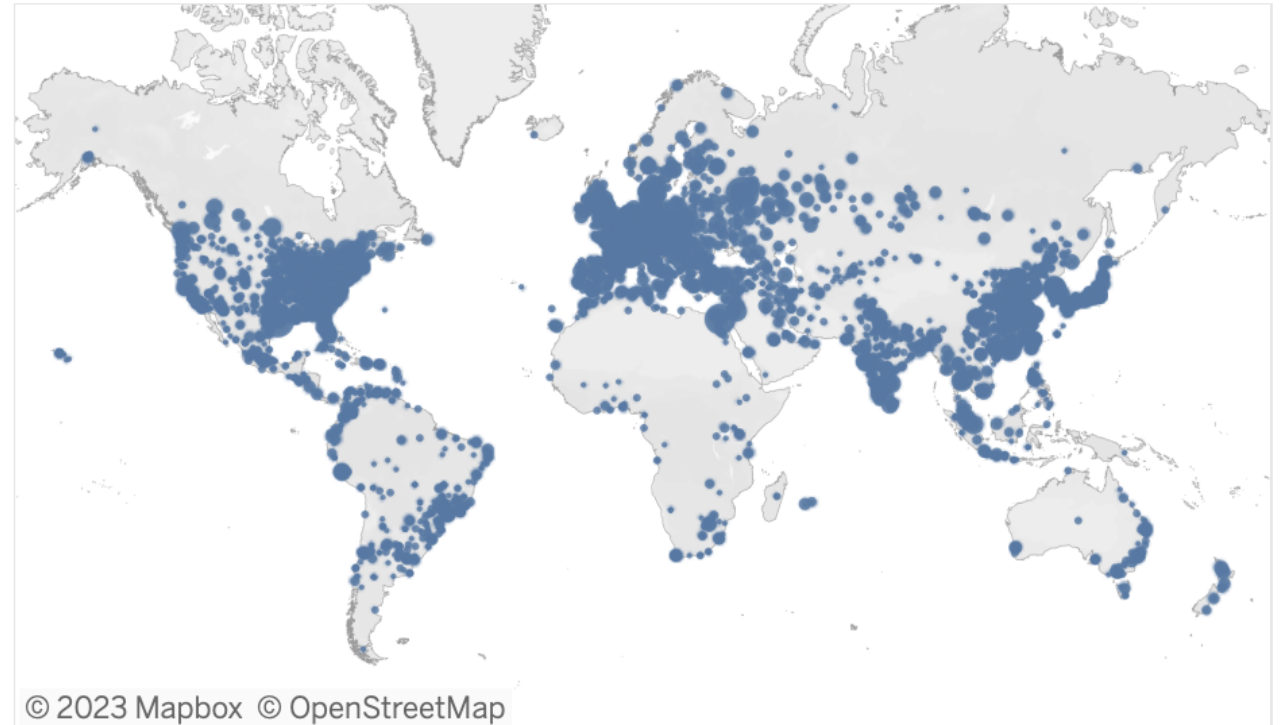
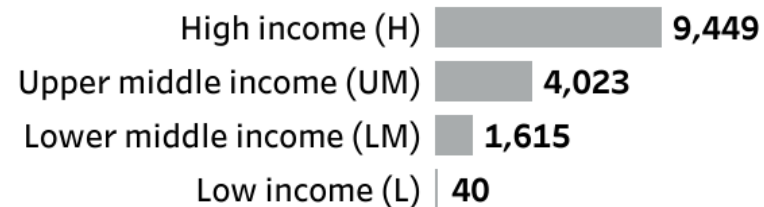
## Equipment type

(Updated on : 09/03/2023 13:55:27)



## Equipment per income groups

(Updated on : 09/03/2023 13:55:27)



IAEA

DIRAC

Directory of  
RAdiotherapy Centres

# Status of Radiation Therapy Equipment

**156** **7687**

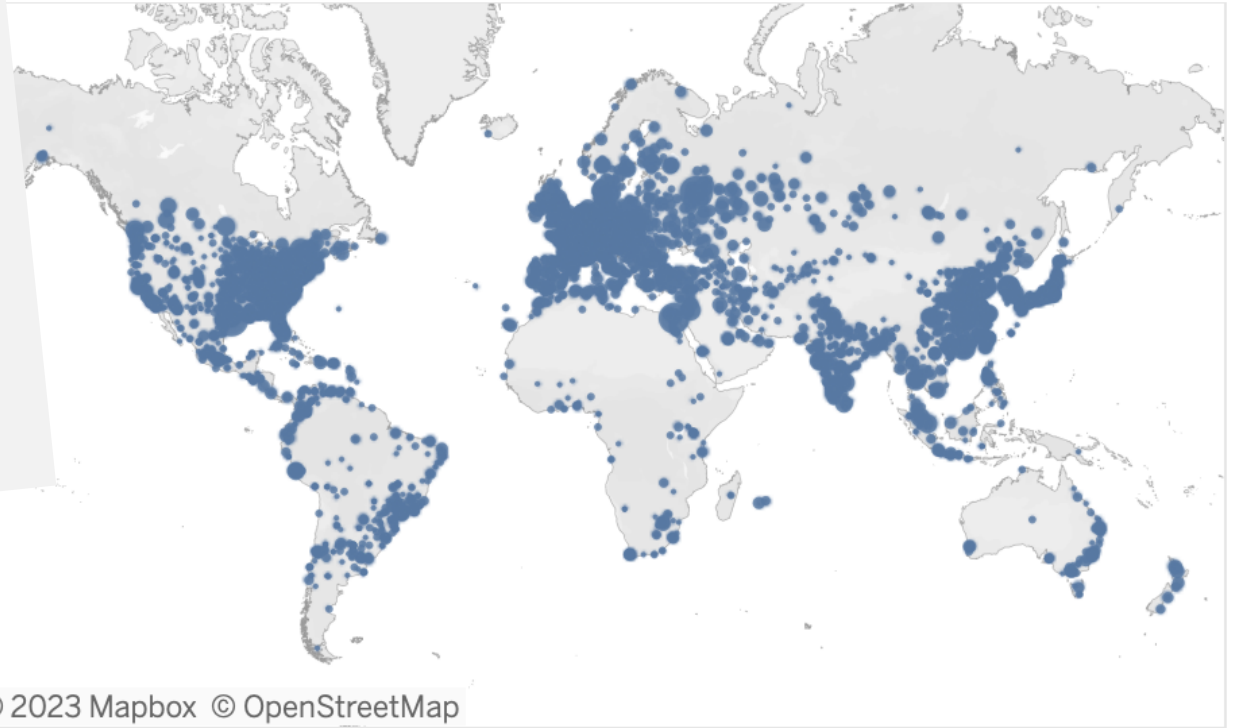
Countries

RT Centres

**15130**

MV Therapy

STELLA (Smart Technologies to Extend Lives with a Linear Accelerator) formed to address the lack of radiotherapy in challenging environments. Supported by ICEC, UK STFC, Lancaster, Oxford, Daresbury lab, CERN, users in LMICs



**Equipment per income groups**  
(Updated on : 09/03/2023 13:55:27)

High income (H)	9,449
Upper middle income (UM)	4,023
Lower middle income (LM)	1,615
Low income (L)	40

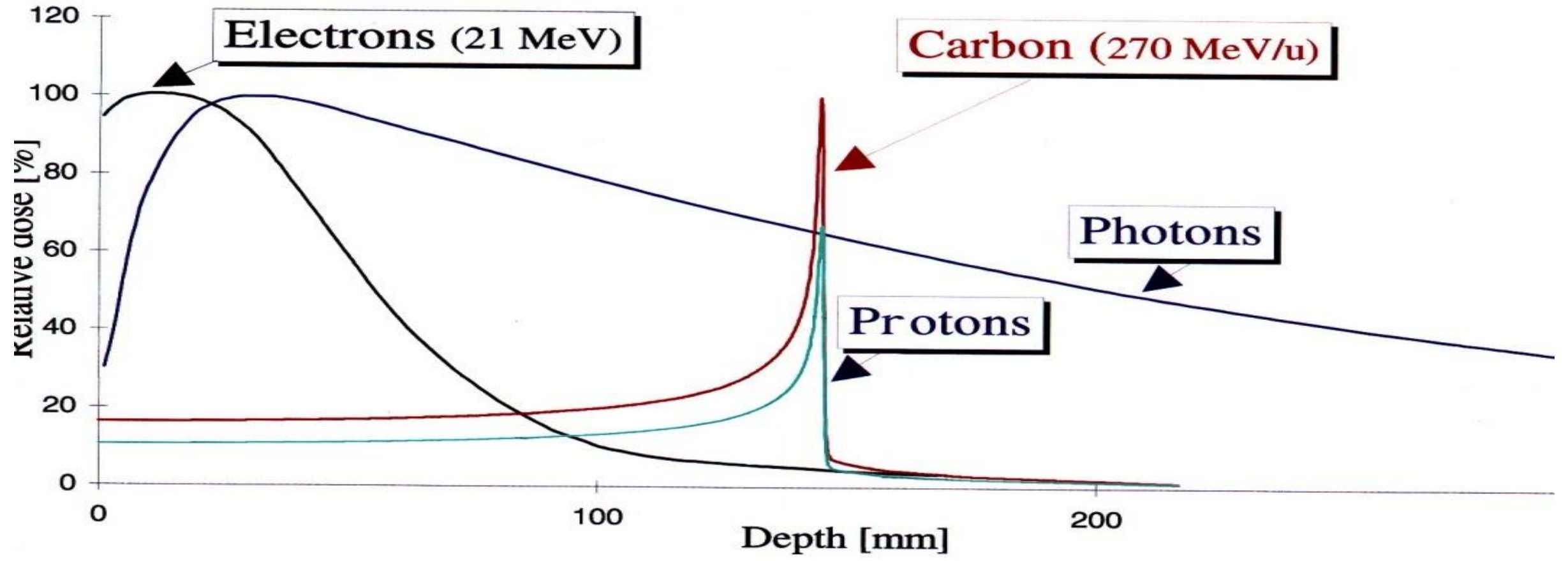


IAEA

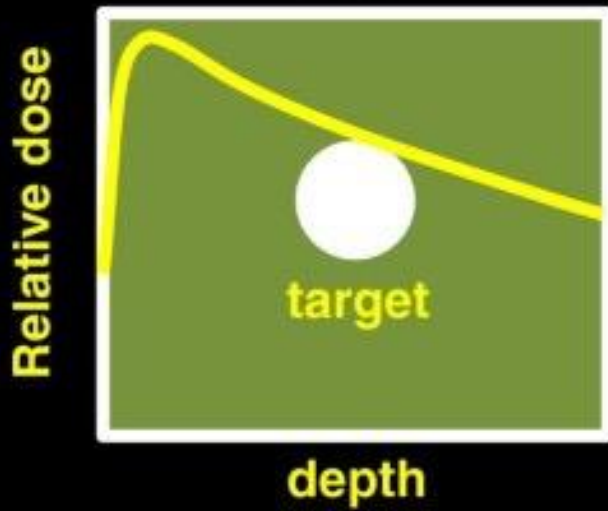
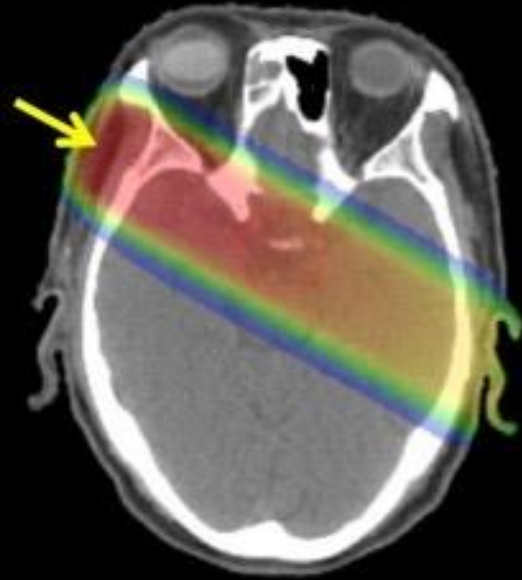
DIRAC

Directory of  
RAdiotherapy Centres

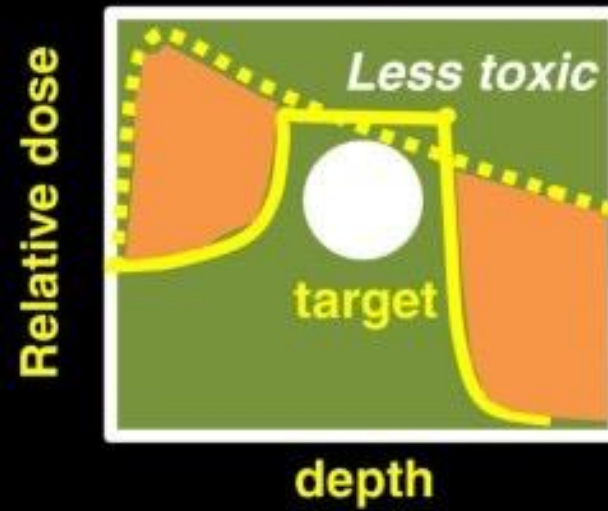
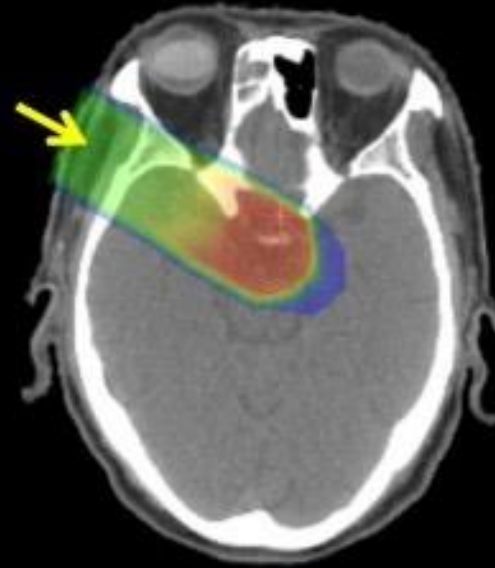
# Protons, ions: hadron therapy, particle therapy, (light, heavy) ion therapy



# X-rays



# Carbon ion beams



<https://link.springer.com/article/10.1186/1878-5085-4-9>



# X-RAY THERAPY

## TREATMENT EXPLAINED

▶ ⏪ 🔍 1:17 / 2:44



## Berkeley

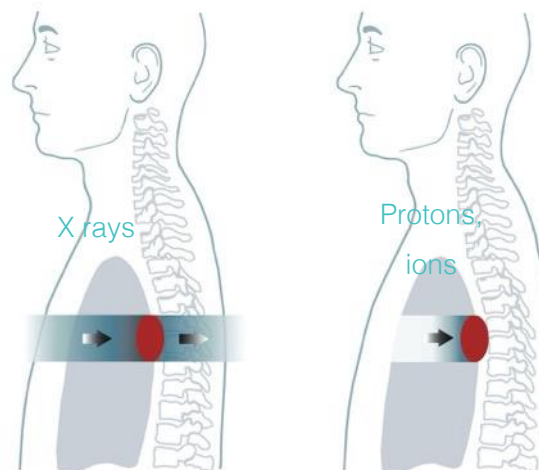
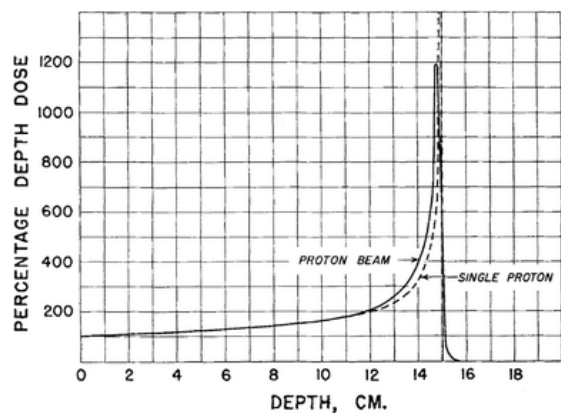
1931 Invention of cyclotron (Ernest Lawrence)

1946 RR Wilson published his seminal paper on particle therapy

1952 First biological investigation with accelerated nuclei (C Tobias and JH Lawrence)

1954 First therapeutic exposure of humans to protons and alphas (Tobias and JH Lawrence)

1975 Clinical trials with accelerated light ions at LBL (Castro)



## Gustav Werner Institute and Theodor Svedberg Laboratory

1949 Synchrocyclotron at the Gustav Werner Institute (Uppsala)

1950s Pre-therapeutic physical experiments with high energy protons (B. Larsson)

1957 First patient treated with proton beam



# $\pi^-$ beam therapy

**1935** Yukawa theory on pi meson

**1947** Discovery of pions

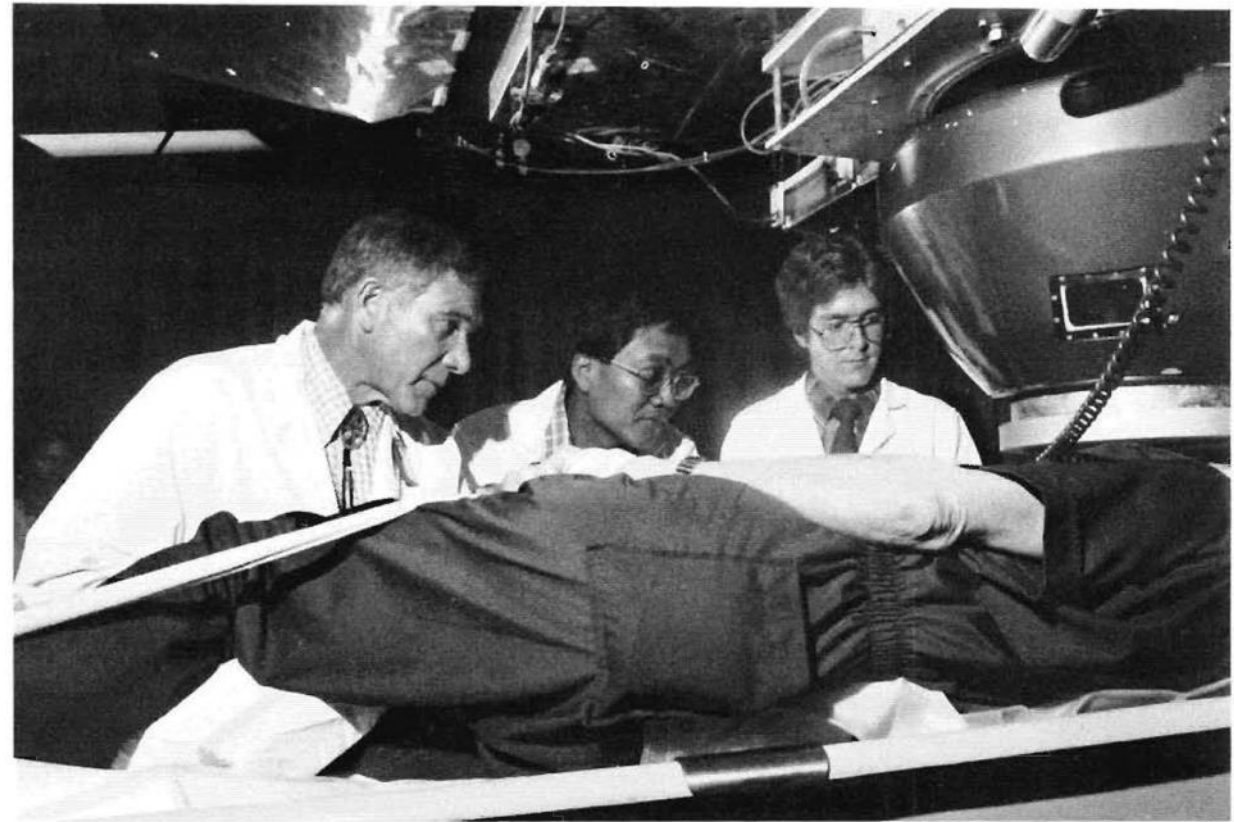
**1951** Possibility of using negative pions for cancer therapy (Tobias and Richman)

**1961** Clinical use of  $\pi^-$  advocated (Fowler and Perkins, Nature 1961)

**'70-'80s** Clinical trials of negative pions at LAMPF, TRIUMF, PSI and Stanford

William T. Chu

EO Lawrence Berkeley National Laboratory  
PTCOG From 1985 to Present and Future



*In a pilot experimental program at LAMPF's Biomedical Facility, about 250 patients were treated with negative pions for a variety of advanced deep-seated tumors. Compared to conventional x-ray therapy, pion therapy is expected to provide improved dose localization and biological effectiveness. Shown positioning a patient under the pion radiotherapy beam are (left to right) Dr. Morton Kligerman, former Director of the University of New Mexico's Cancer Research and Treatment Center, a visiting radiotherapist from Japan, and Dr. Steven Bush, formerly of the University of New Mexico. The hardware at the upper right includes a beam collimator, a dose monitor, and a device for changing the penetration depth of the pions.*

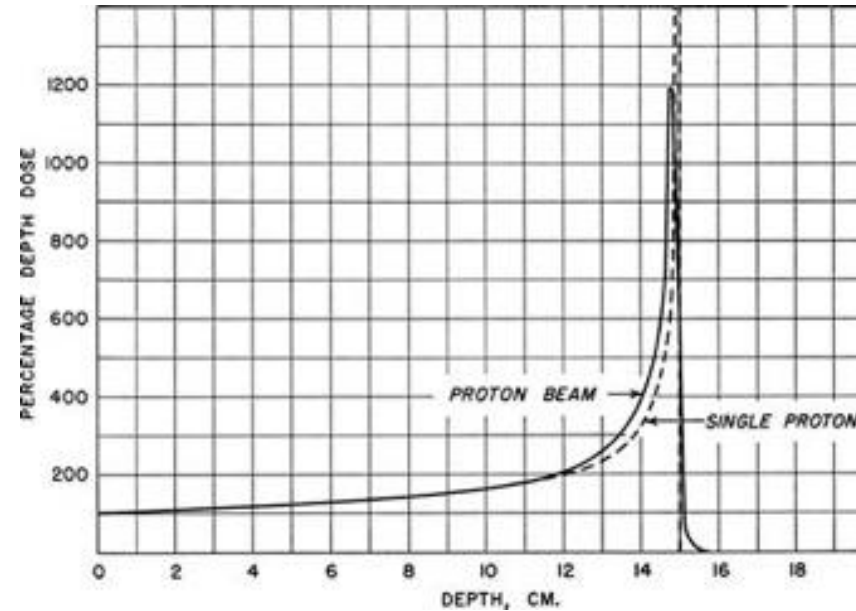
LAMPF: a dream and a gamble



# From physics labs...



1932 - E. Lawrence  
First cyclotron



1946 – proton therapy  
proposed by R. Wilson

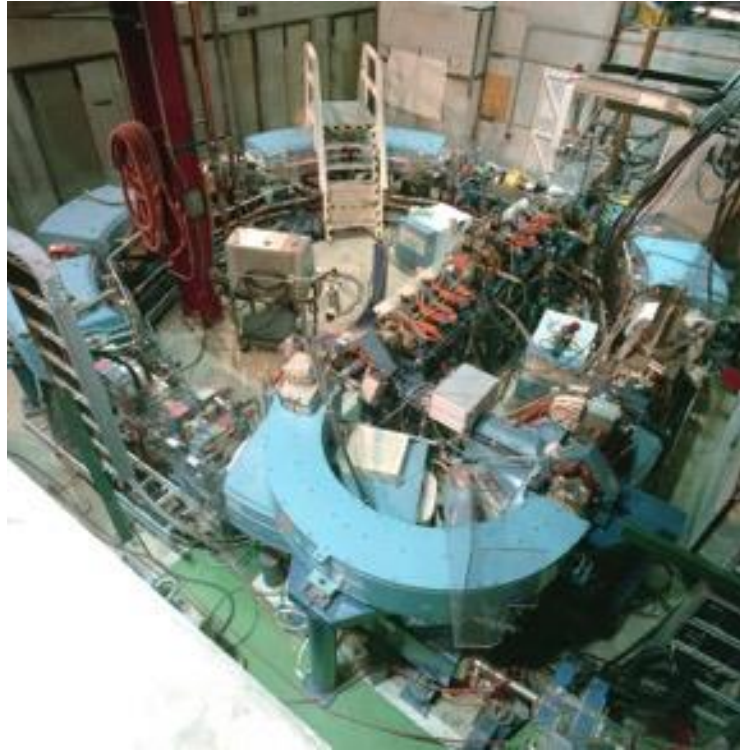


1954 – Berkeley treats  
the first patient

# ...to clinics



1989  
Clatterbridge UK



1990  
Loma Linda USA



1994  
HIMAC Japan

# How to make it better

Image-Guided Radiation Therapy

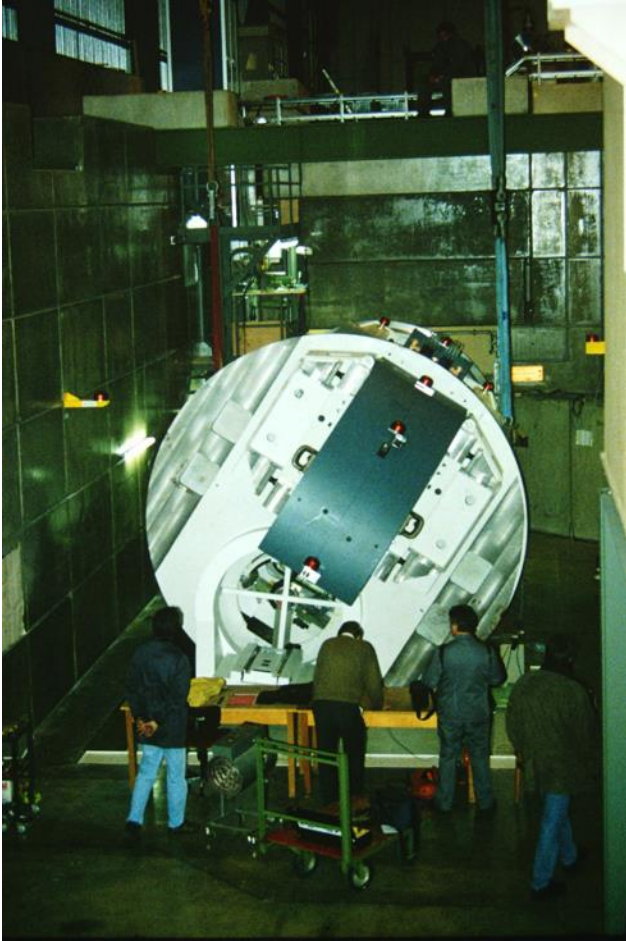
Intensity-modulated radiation therapy

MRI-guided radiation therapy

Dynamic arc delivery techniques

...

# Pioneers in scanned beam delivery



Building Gantry 1 back in the 1990s  
(Photo: Paul Scherrer Institute)



1998  
Pilot project at GSI  
Germany and proposal for HIT facility

# Status of Radiation Therapy Equipment

**20** **104**

Countries RT Centres

**107**

Light Ion Therapy

## Equipment type

(Updated on : 09/03/2023 13:55:27)

MV Therapy 15,130

Brachytherapy 3,336

Light Ion Therapy **107**

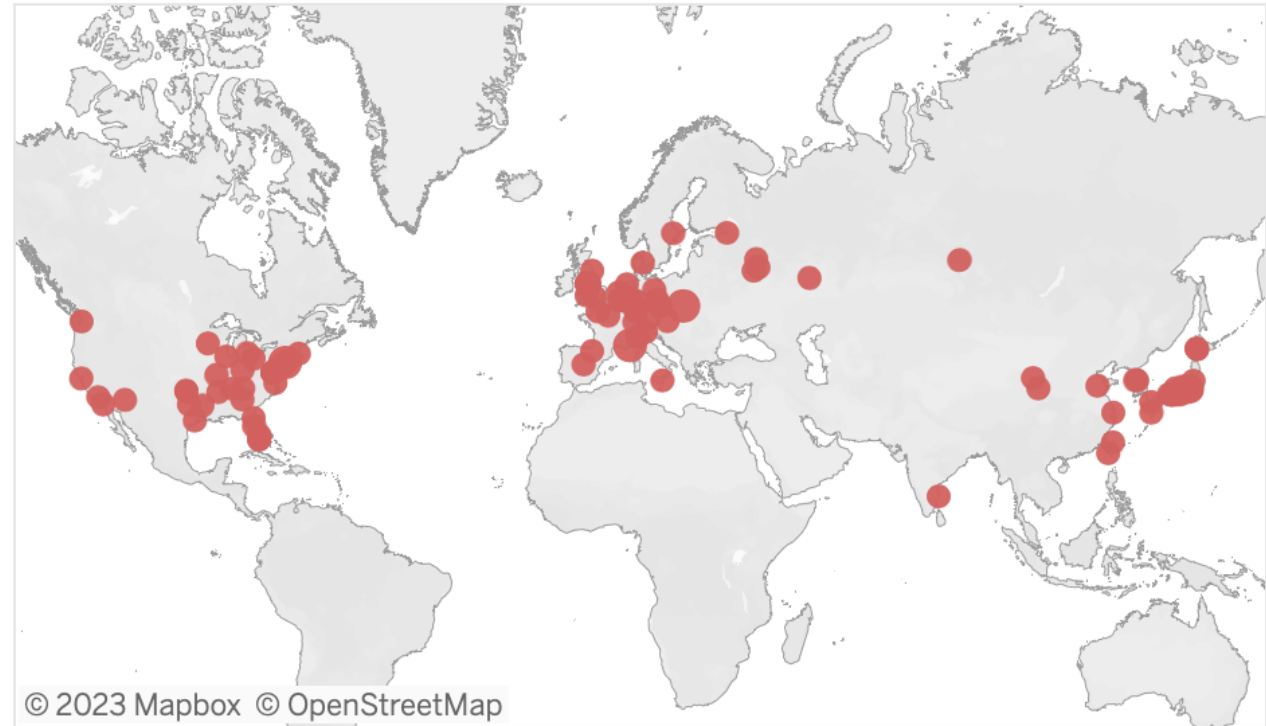
## Equipment per income groups

(Updated on : 09/03/2023 13:55:27)

High income (H) 96

Upper middle income (UM) 10

Lower middle income (LM) 1



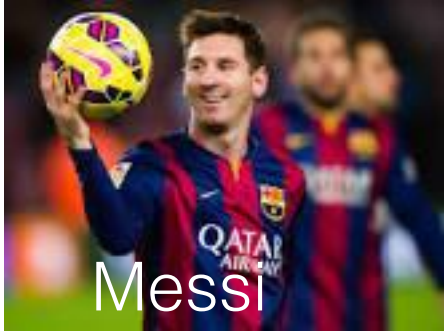
IAEA

DIRAC

Directory of  
RAdiotherapy Centres



200



Messi



Higuain



Multi heavy ions  
(protons +  
carbon ions)



Mandžukić

proton multi-room

2



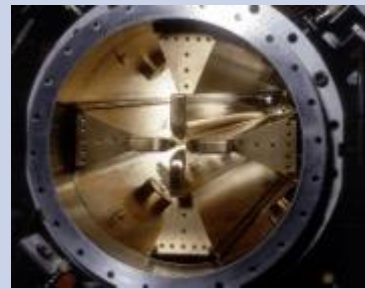
Karius

proton single-  
room

Courtesy  
(I'll never thank him enough!)  
Marco Durante (GSI)  
JENAS 2019

# Protons: the LINAC way

<p><b>1990</b> RFQ2 200 MHz 0.5 MeV /m Weight :1200kg/m Ext. diametre : ~45 cm</p>	<p><b>2007</b> LINAC4 RFQ 352 MHz 1MeV/m Weight : 400kg/m Ext. diametre : 29 cm</p>	<p><b>2014</b> HF RFQ 750MHz 2.5MeV/m Weight : 100 kg/m Ext. diametre : 13 cm</p>
--	---	---



**Compact High-Frequency Radio Frequency Quadrupole (RFQ)**  
 M. Vretenar, A. Dallochio, V. A. Dimov, M. Garlasché, A. Grudiev, A. M. Lombardi, S. Mathot, E. Montesinos, M. Timmins,  
 "A Compact High-Frequency RFQ for Medical Applications", in Proc. LINAC2014, Geneva, Switzerland, September 2014

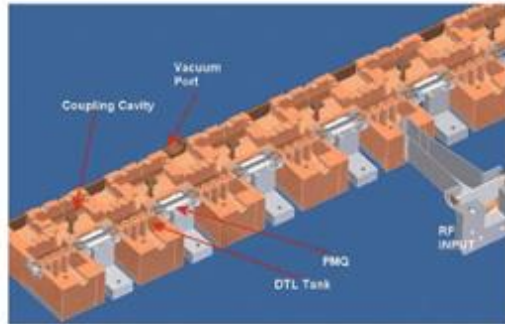
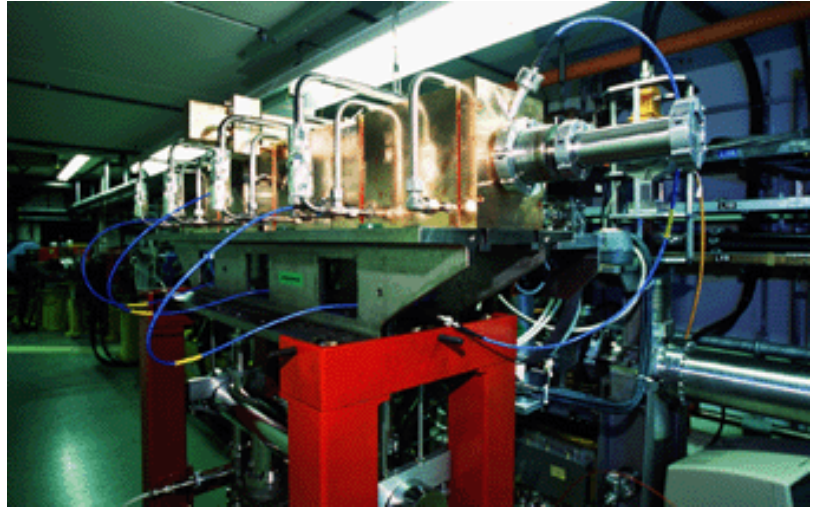


Fig. 4. TOP-IMPLART SCDTL structure: (left) schematic (right) 18-24 MeV booster built for the SPARKLE Company.

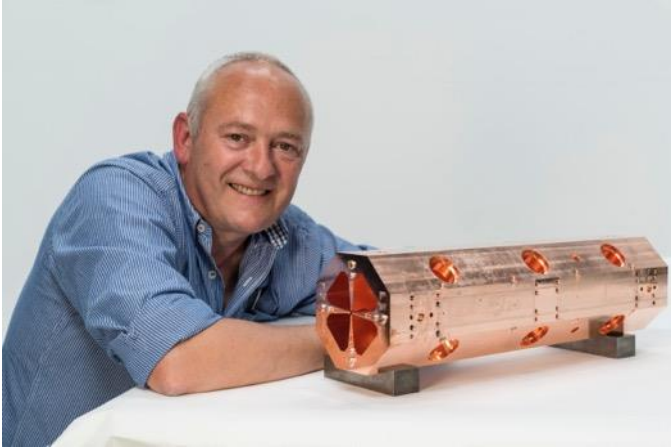
**TOP IMPLART**  
 C. Ronsivalle, M. Carpanese, C. Marino, G. Messina, L. Picardi, S. Sandri, E. Basile, B. Caccia, D.M. Castelluccio, E. Cisbani, S. Frullani, F. Ghio, V. Macellari, M. Benassi, M. D'Andrea, L. Strigari, The TOP-IMPLART project, Eur. Phys. J. Plus 126: 68 (2011) 1-15,  
<http://dx.doi.org/10.1140/epjp/i2011-11068-x>.



**Linac BOOSTER (LIBO)**  
 U. Amaldi et al., "LIBO-a linac booster for protontherapy: construction and test of a prototype," Nucl. Instrum. Meth- ods Phys. Res. A, vol. 521, pp. 512-529, 2004.

# Toward clinical proton therapy LINACs

The RFQ accelerating structure entirely manufactured by AVO (under CERN licence)  
Nominal energy for the full system reached in Sep 2022



CERN proton therapy RFQ (5 MeV / 2m)



TOP IMPLART under development and construction by ENEA in collaboration with the Italian Institute of Health (ISS) and the Oncological Hospital Regina Elena-IFO.

Status in March 2021\*: running at 55.5 MeV

\* <https://www.accelerators.enea.it/TopImplartStatus&Schedules/index.htm>

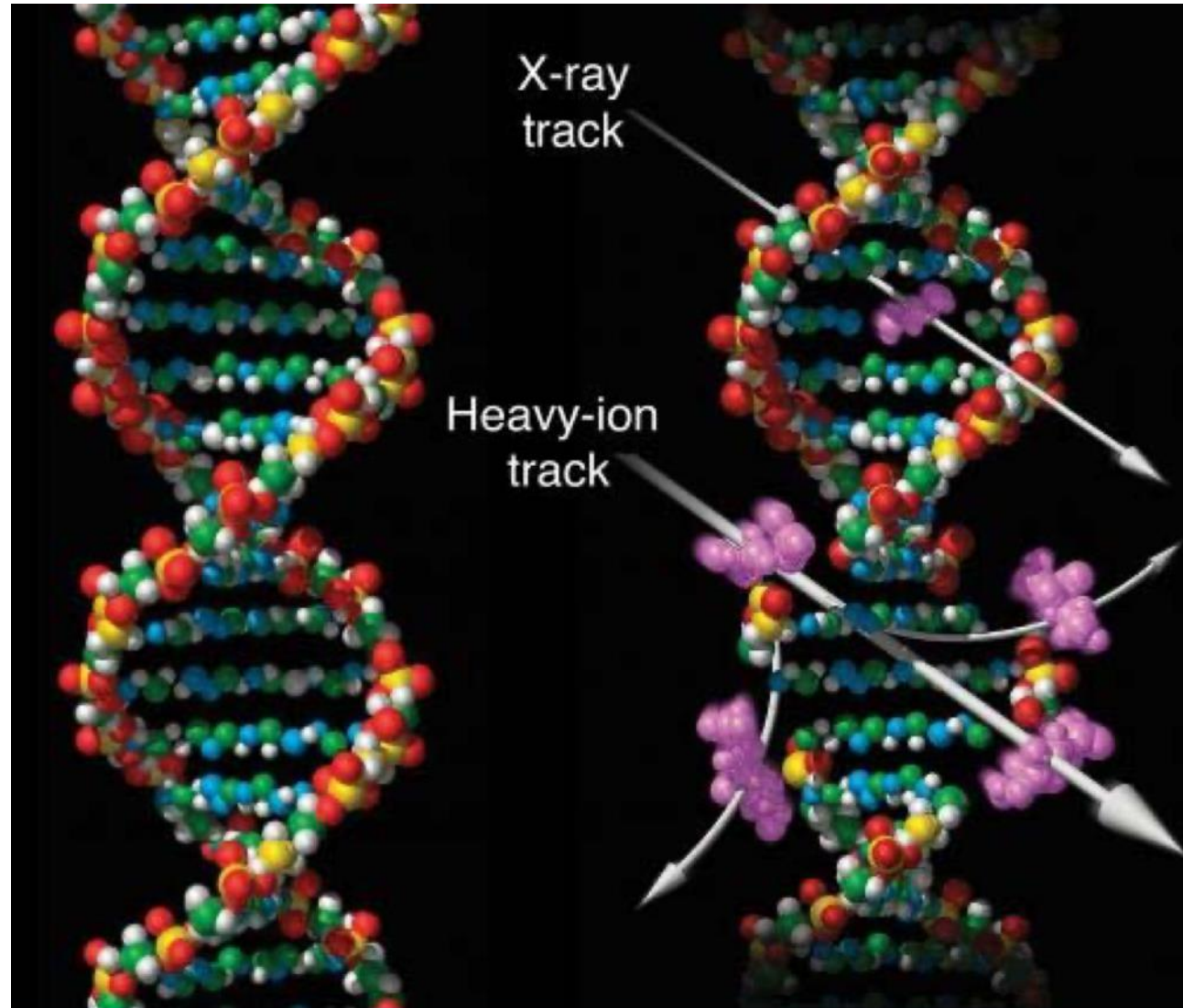
ERHA (Enhanced Radiotherapy with Hadrons) is the innovative proton therapy system being developed by LinearBeam for the treatment of tumors.

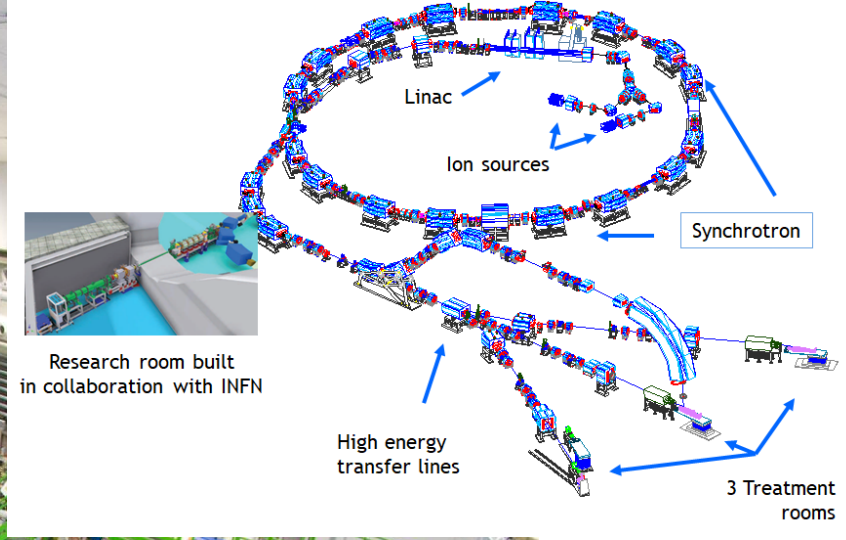
Collaboration with (among others) ENEA, INFN.





# Carbon ions





Sources to generate

1 RF cavity to accelerate

16 Dipoles to bend

20 Correctors to steer

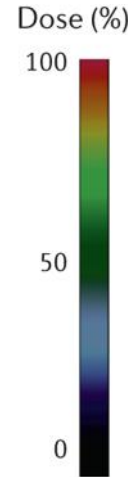
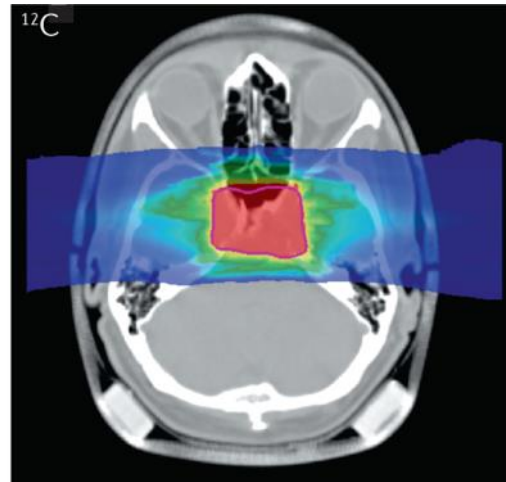
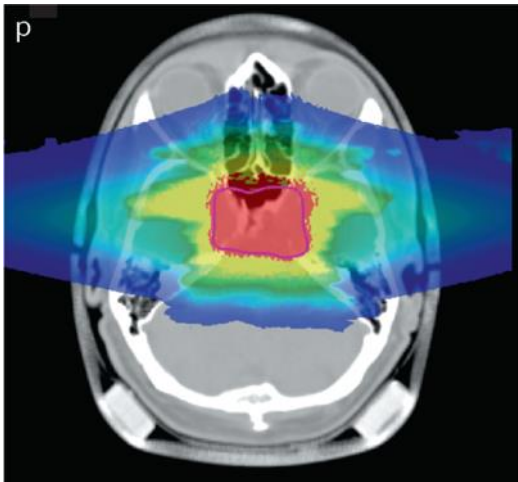
Linac to pre-accelerate

24 Quadrupoles to focus

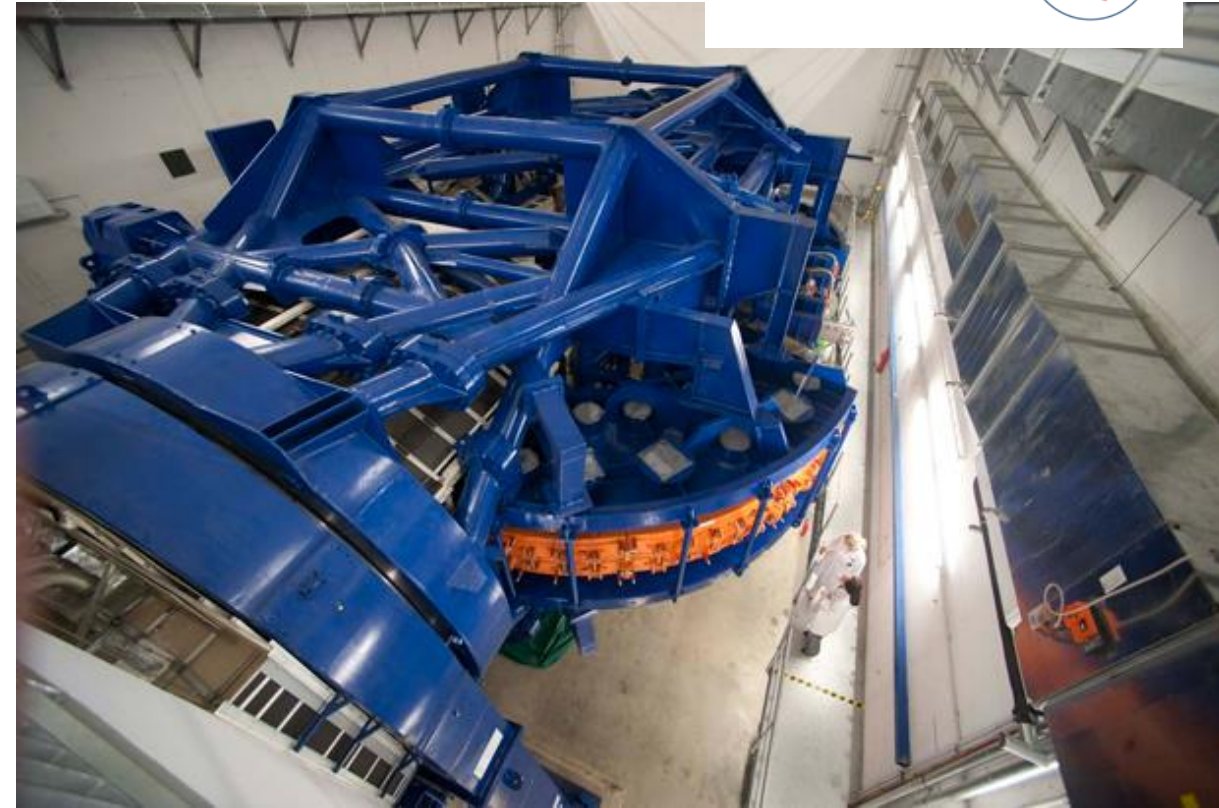
From pioneering rasterscanning & carbon ion pilot project @



440 patients  
1998-2008



The image shows an optimized plan with two opposite fields for a chordoma patient using protons (left) or 12C ions (right).



Since 2009\*:  
2841 patients with p  
3793 patients with C-ion

\* Until Dec 2020, source ptcog.ch

## PROTON-ION MEDICAL MACHINE STUDY (PIMMS) PART II

Accelerator Complex Study Group\*  
supported by the Med-AUSTRON, Onkologic-2000 and the TERA Foundation  
and hosted by CERN

### ABSTRACT

The Proton-Ion Medical Machine Study (PIMMS) group was formed following an agreement between the Med-AUSTRON (Austria) and the TERA Foundation (Italy) to combine their efforts in the design of a cancer therapy synchrotron capable of accelerating either light ions or protons. CERN agreed to support and host this study in its PS Division. A close collaboration was also set up with GSI (Germany). The study group was later joined by Onkologic-2000 (Czech Republic). Effort was first focused on the theoretical understanding of slow extraction and the techniques required to produce a smooth beam spill for the conformal treatment of complex-shaped tumours with a sub-millimetre accuracy by active scanning with proton and carbon ion beams. Considerations for passive beam spreading were also included for protons. The study has been written in two parts. The more general and theoretical aspects are recorded in Part I and the specific technical design considerations are presented in the present volume, Part II. An accompanying CD-ROM contains supporting publications made by the team and data files for calculations. The PIMMS team started its work in January 1996 in the PS Division and continued for a period of four years.

\*Full-time members: L. Badano<sup>1)</sup>, M. Benedikt<sup>2)</sup>, P.J. Bryant<sup>2)</sup> (Study Leader), M. Crescenti<sup>1)</sup>, P. Holy<sup>3)</sup>, A. Maier<sup>2)4)</sup>, M. Pullia<sup>1)</sup>, S. Reimoser<sup>2)4)</sup>, S. Rossi<sup>1)</sup>,  
Part-time members: G. Borri<sup>1)</sup>, P. Knaus<sup>1)2)</sup>  
Contributors: F. Gramatica<sup>1)</sup>, M. Pavlovic<sup>5)</sup>, L. Weisser<sup>5)</sup>

1) TERA Foundation, via Puccini, 11, I-28100 Novara.

2) CERN, CH 1211 Geneva-23.

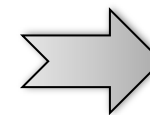
3) Oncology-2000 Foundation, Na Morani 4, CZ-12808 Prague 2.

4) Med-AUSTRON, c/o RIZ, Prof. Dr. Stephan Korenstr.10, A-2700 Wr. Neustadt.

5) Sommer & Partner Architects Berlin (SPB), Hardenbergplatz 2, D-10623 Berlin.

Geneva, Switzerland  
May 2000

From PIMMS @



fondazione CNAO



# Patient treatment at MedAustron



Since 2016:  
1174 Patients  
30600 Single Fractions

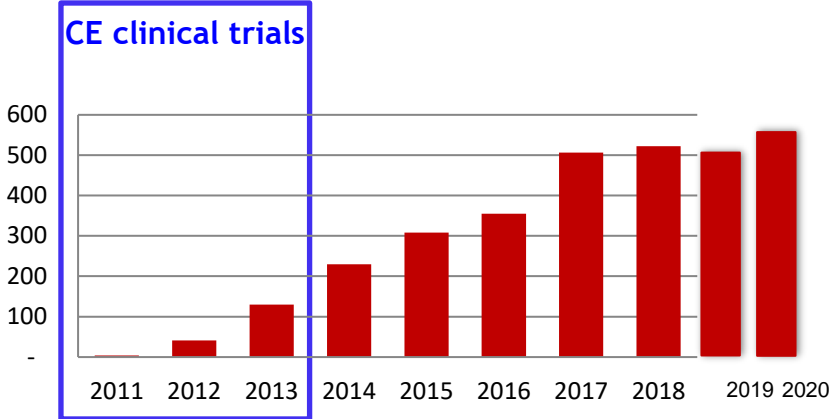
MedAustron 

<b>CNS</b>	28%
<b>Head &amp; Neck</b>	20%
<b>Pediatrics</b>	15%
<b>Re-Irradiation</b>	15%
<b>Sarcoma</b>	9%
<b>Skull Base</b>	7%
<b>Prostate</b>	3%
<b>Gastrointestinal (upper)</b>	2%
<b>Gastrointestinal (lower)</b>	<1%
<b>Gynecological Tumors</b>	<1%
<b>Urogenital Tumors</b>	<1%
<b>Breast/Mamma-Ca</b>	<1%

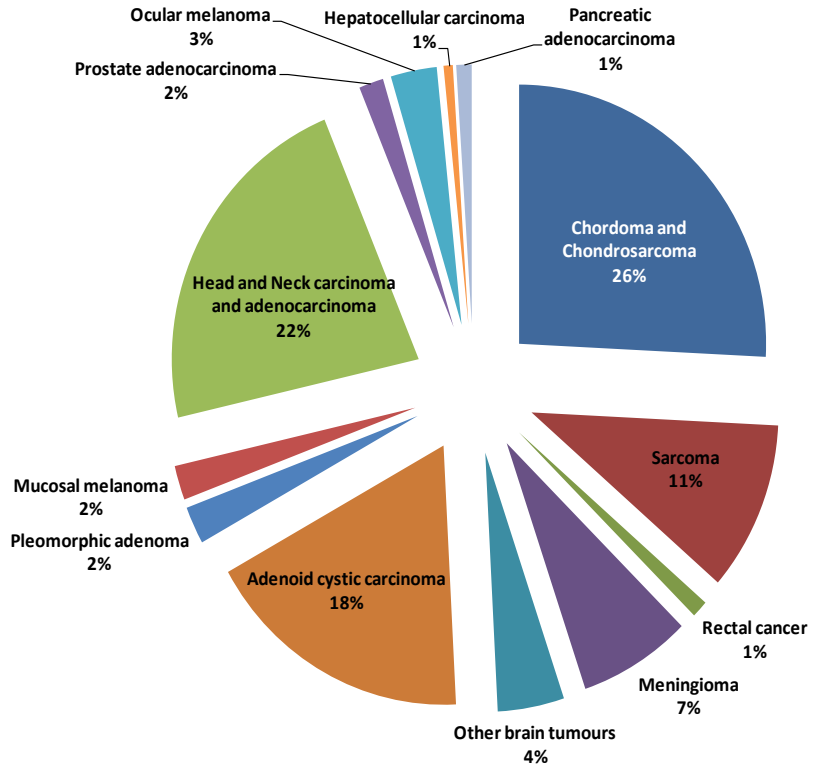
Values October 2021 • values rounded

# Patient treatment at CNAO

Since 2011:  
3700 Patients  
55% C-ions  
45% Protons



Patients per year



Non oncological application: ventricular arrhythmia  
(Collaboration with San Matteo Hospital, Pavia)  
Published: European Journal of Heart Failure

# SCIENTIFIC REPORTS

**OPEN**

## Feasibility Study on Cardiac Arrhythmia Ablation Using High-Energy Heavy Ion Beams

H. Immo Lehmann<sup>1,4</sup>, Christian Graeff<sup>2,4</sup>, Palma Simoniello<sup>2</sup>, Anna Constantinescu<sup>2</sup>, Mitsuru Takami<sup>1</sup>, Patrick Lugenbiel<sup>3</sup>, Daniel Richter<sup>2,4</sup>, Anna Eichhorn<sup>2</sup>, Matthias Prall<sup>2</sup>, Robert Kaderka<sup>2</sup>, Fine Fiedler<sup>5</sup>, Stephan Helmbrecht<sup>5</sup>, Claudia Fournier<sup>2</sup>, Nadine Erbedinger<sup>2</sup>, Ann-Kathrin Rahm<sup>3</sup>, Rasmus Rivinius<sup>3</sup>, Dierk Thomas<sup>3</sup>, Hugo A. Katus<sup>3</sup>, Susan B. Johnson<sup>2</sup>, Kay D. Parker<sup>2</sup>, Jürgen Debus<sup>6</sup>, Samuel J. Asirvatham<sup>1</sup>, Christoph Bert<sup>2,4</sup>, Marco Durante<sup>2,7</sup> & Douglas L. Packer<sup>1</sup>

Received: 08 August 2016

Accepted: 09 November 2016

Published: 20 December 2016

> *Eur J Heart Fail.* 2020 Nov 12. doi: 10.1002/ejhf.2056. Online ahead of print.

## The First-in-Man Case of Non-invasive Proton Radiotherapy to Treat Refractory Ventricular Tachycardia in Advanced Heart Failure

Veronica Dusi<sup>1,2</sup>, Viviana Vitolo<sup>3</sup>, Laura Frigerio<sup>1,4</sup>, Rossana Totaro<sup>1,4</sup>, Adele Valentini<sup>5</sup>, Amelia Barcellini<sup>3</sup>, Alfredo Mirandola<sup>3</sup>, Giovanni Battista Perego<sup>6</sup>, Michela Coccia<sup>2</sup>, Alessandra Greco<sup>4</sup>, Stefano Ghio<sup>4</sup>, Francesca Valvo<sup>3</sup>, Gaetano Maria De Ferrari<sup>7</sup>, Massimiliano Gnechi<sup>1,2</sup>, Luigi Oltrona Visconti<sup>4</sup>, Roberto Rordorf<sup>1,4</sup>

Affiliations + expand

PMID: 33179329 DOI: 10.1002/ejhf.2056





# Challenges for next-generation particle-therapy machines

Cost-effective technologies

Reduced footprint

New treatment regimes (e.g. FLASH, microbeams) and fractionation schedules

Multi-ions

Radiobiology research integrated in the facility

Many challenges in common with those for future particle physics facilities. Various initiatives starting/on-going.

KT Seminars

## The CERN Next Ion Medical Machine Study: towards a new generation of accelerators for cancer therapy

by Maurizio Vretenar (CERN)

<https://indico.cern.ch/event/956260/>

Monday 19 Oct 2020, 14:00 → 16:30 Europe/Zurich

**Workshop**  
Location Archamps, France  
Venue: European Scientific Institute (ESI)  
Dates: 19-21 June 2018

**Ideas and technologies for a next-generation facility for medical research and therapy with ions**

**MAIN TOPICS:**

- ▶ EXISTING FACILITIES
- ▶ CURRENT INITIATIVES
- ▶ NEW TECHNOLOGIES
- ▶ DESIGN PARAMETERS
- ▶ TECHNICAL OPTIONS

<https://indico.cern.ch/b/ims2018>

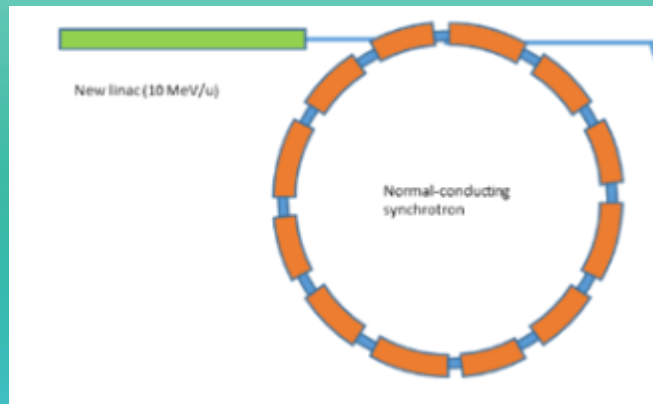
<b>ORGANIZATION</b>	<b>International Advisory Committee</b>	<b>Programme Committee</b>	<b>Organizing Committee</b>
	U. Amaldi (IFEA, Italy)	M. Cirilli (CERN, Switzerland)	V. Branner (CERN, Switzerland)
	F. Bordry (CERN, Switzerland)	M. Dossanj (CERN/ENLIGHT, Switzerland)	Y. Foka (GSI & FAIR, Germany)
	J. Debus (HTI, Germany)	Y. Foka (GSI & FAIR, Germany)	B. Holland (ESI, France)
	M. Durante (IFPA, INFN, Italy)	C. Geetha (GSI & FAIR, Germany)	M. Jenik (MSI, Poland)
	P. Giubellino (GSI & FAIR, Germany)	M. Pullia (CNAO, Italy)	A. Kataneva (J.B. Sossin & SPbSU, Russia)
	R. Miralbell (HUG, Switzerland)	L. Rinolfi (ESI, France)	L. Rinolfi (ESI, France)
	S. Rossi (CNAO, Italy)	M. Vretenar (CERN, Switzerland)	M. Vretenar (CERN, Switzerland)
	H. Specht (Univ. of Heidelberg, Germany)		
	E. Tesmetz (CERN, Switzerland)		
U. Weinrich (GSI & FAIR, Germany)			
A. Zens (MedAustron, Austria)			



# Three alternative accelerator designs

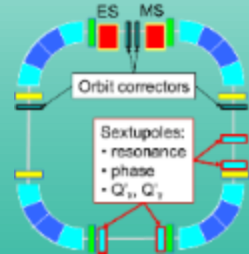
## Improved synchrotron (warm)

Equipped with several innovative features: multi-turn injection for higher beam intensity, new injector at higher gradient and energy, multiple extraction schemes, multi-ion. Circumference ~ 75 m



## Improved synchrotron (superconducting)

Equipped with the same innovative features as warm, but additionally 90° superconducting magnets. Circumference ~ 27 m

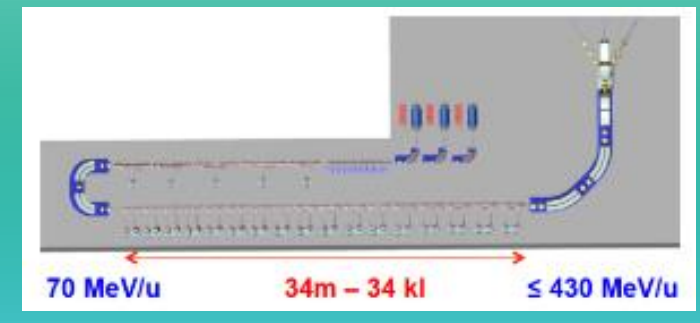
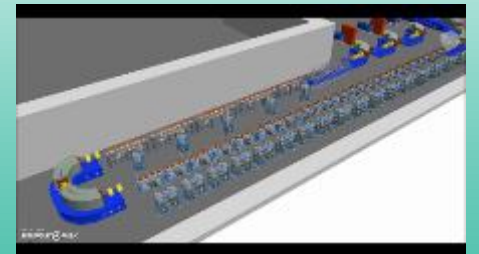


Courtesy: TERA



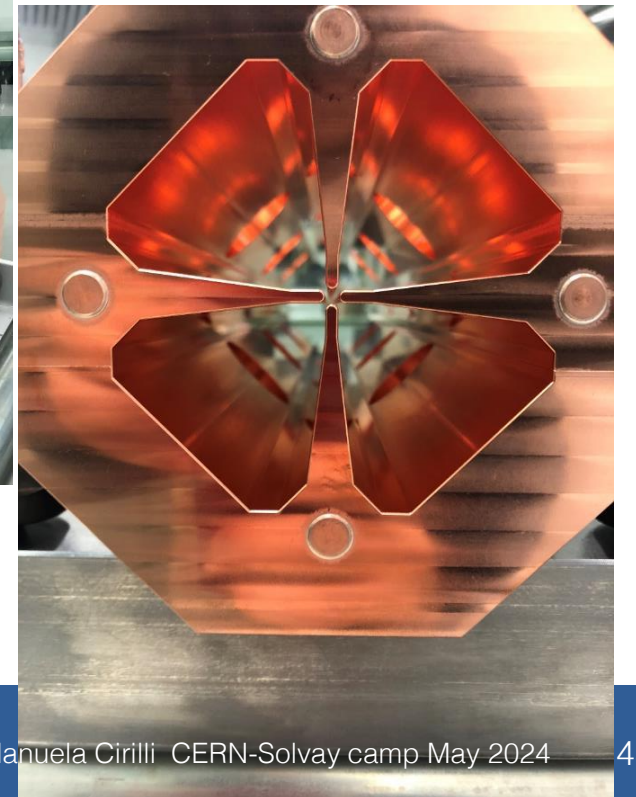
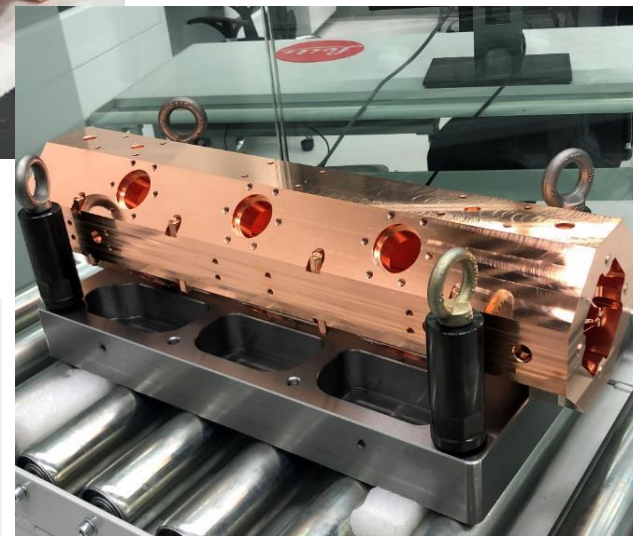
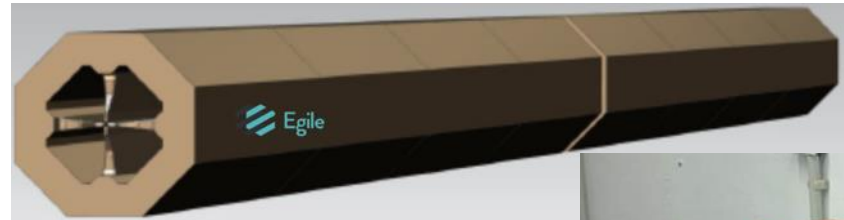
## Linear accelerator

Linear sequence of accelerating cells, high pulse frequency. Length ~ 53 m



Other options considered as less interesting because of cost and/or required R&D: RC synchrotron, FFAG, SC cyclotron, PWFA

# The RFQ for C<sup>6+</sup> LINAC option



Collaboration CERN-CIEMAT-CDTI-Spanish industry  
2.0 m long  
750 MHz  
Will deliver Carbon (or Helium) at 5 MeV (total energy)  
Designed at CERN built in Spanish Industry

# R&D on gantries

GaToroid: A Novel Concept for a Superconducting Compact and Lightweight Gantry for Hadron Therapy



Collaboration CNAO-  
INFN-CERN-MedAustron

Developing enabling  
technologies for a next-  
generation compact and  
lightweight rotating gantry



# FLASH therapy – a growing clinical interest

NATURE

May 23, 1959 VOL. 183

## Modification of the Oxygen Effect when Bacteria are given Large Pulses of Radiation

D. L. DEWEY  
J. W. BOAG

Research Unit in Radiobiology,  
British Empire Cancer Campaign,  
Mount Vernon Hospital,  
Northwood.

> [Sci Transl Med](#). 2014 Jul 16;6(245):245ra93. doi: 10.1126/scitranslmed.3008973.

## Ultrahigh dose-rate FLASH irradiation increases the differential response between normal and tumor tissue in mice

Vincent Favaudon<sup>1</sup>, Laura Caplier<sup>2</sup>, Virginie Monceau<sup>3</sup>, Frédéric Pouzoulet<sup>4</sup>, Mano Sayarath<sup>4</sup>, Charles Fouillade<sup>4</sup>, Marie-France Poupon<sup>4</sup>, Isabel Brito<sup>5</sup>, Philippe Hupé<sup>6</sup>, Jean Bourhis<sup>7</sup>, Janet Hall<sup>4</sup>, Jean-Jacques Fontaine<sup>2</sup>, Marie-Catherine Vozenin<sup>8</sup>

Affiliations + expand

PMID: 25031268 DOI: [10.1126/scitranslmed.3008973](#)

In vitro studies suggested that sub-millisecond pulses of radiation elicit less genomic instability than continuous, protracted irradiation at the same total dose. To determine the potential of ultrahigh dose-rate irradiation in radiotherapy, we investigated lung fibrogenesis in C57BL/6J mice exposed either to short pulses ( $\leq 500$  ms) of radiation delivered at ultrahigh dose rate ( $\geq 40$  Gy/s, FLASH) or to conventional dose-rate irradiation ( $\leq 0.03$  Gy/s, CONV) in single doses. The growth of human HBCx-12A and HEP-2 tumor xenografts in nude mice and syngeneic TC-1 Luc(+) orthotopic lung tumors in C57BL/6J mice was monitored under similar radiation conditions. CONV (15 Gy) triggered lung fibrosis associated with activation of the TGF- $\beta$  (transforming growth factor- $\beta$ ) cascade, whereas no complications developed after doses of FLASH below 20 Gy for more than 36 weeks after irradiation. FLASH irradiation also spared normal smooth muscle and epithelial cells from acute radiation-induced apoptosis, which could be reinduced by administration of systemic TNF- $\alpha$  (tumor necrosis factor- $\alpha$ ) before irradiation. In contrast, FLASH was as efficient as CONV in the repression of tumor growth. Together, these results suggest that FLASH radiotherapy might allow complete eradication of lung tumors and reduce the occurrence and severity of early and late complications affecting normal tissue.

# FLASH therapy – a growing clinical interest



Contents lists available at ScienceDirect

Radiotherapy and Oncology

journal homepage: www.thegreenjournal.com

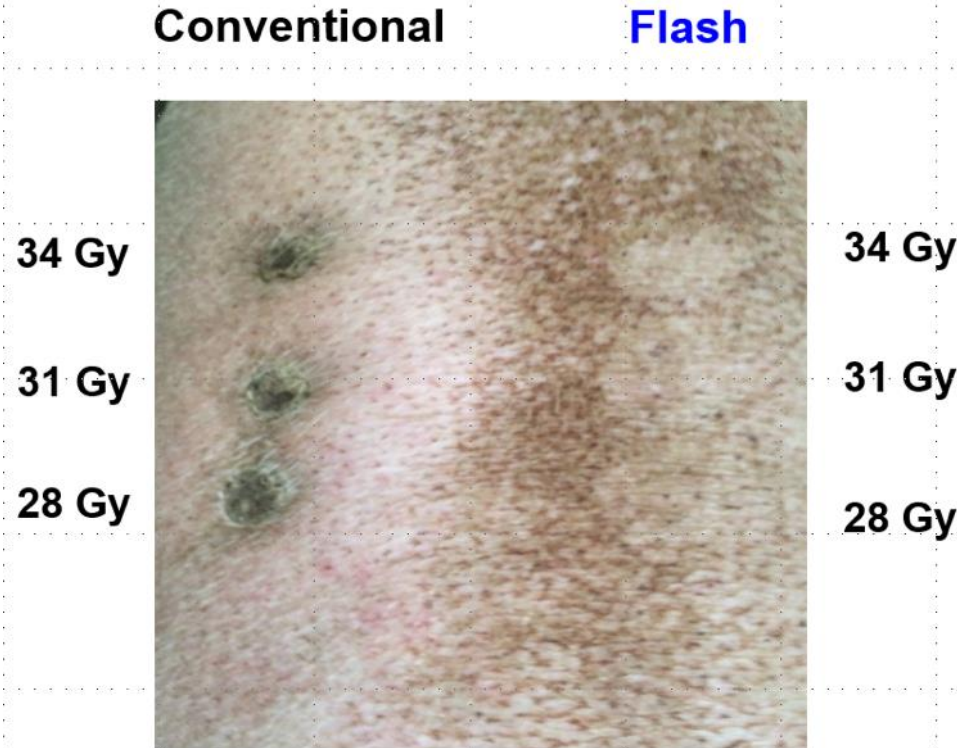


Original Article

## Treatment of a first patient with FLASH-radiotherapy

Jean Bourhis<sup>a,b,\*</sup>, Wendy Jeanneret Sozzi<sup>a</sup>, Patrik Gonçalves Jorge<sup>a,b,c</sup>, Olivier Gaide<sup>d</sup>, Claude Bailat<sup>c</sup>, Frédéric Duclos<sup>a</sup>, David Patin<sup>a</sup>, Mahmut Ozsahin<sup>a</sup>, François Bochud<sup>c</sup>, Jean-François Germond<sup>c</sup>, Raphaël Moeckli<sup>c,1</sup>, Marie-Catherine Vozenin<sup>a,b,1</sup>

<sup>a</sup> Department of Radiation Oncology, Lausanne University Hospital and University of Lausanne; <sup>b</sup> Radiation Oncology Laboratory, Department of Radiation Oncology, Lausanne University Hospital and University of Lausanne; <sup>c</sup> Institute of Radiation Physics, Lausanne University Hospital and University of Lausanne; and <sup>d</sup> Department of Dermatology, Lausanne University Hospital and University of Lausanne, Switzerland

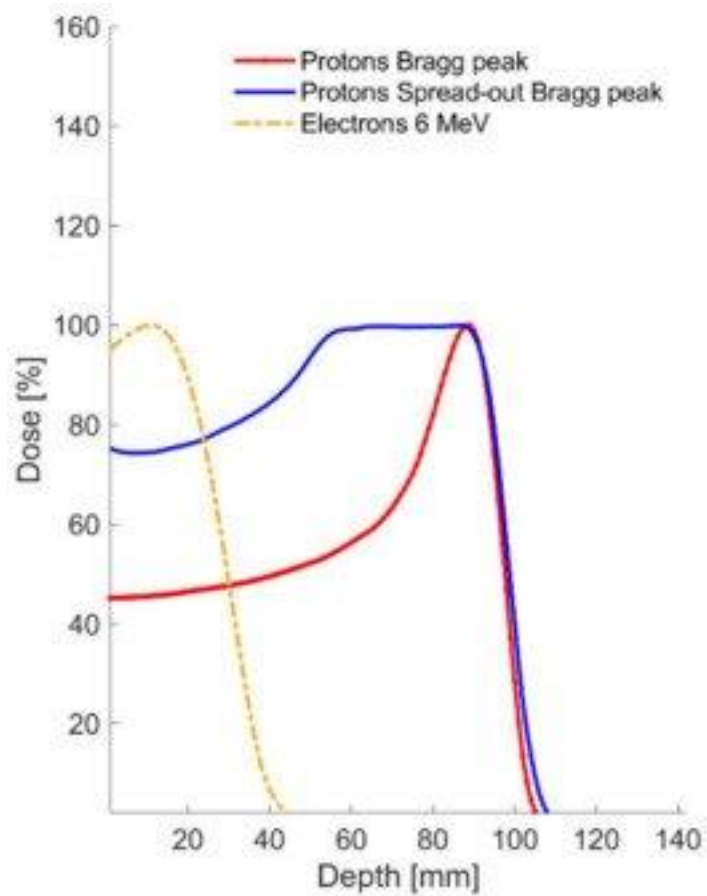


Vozenin et al  
*Clin Cancer Res*  
2018

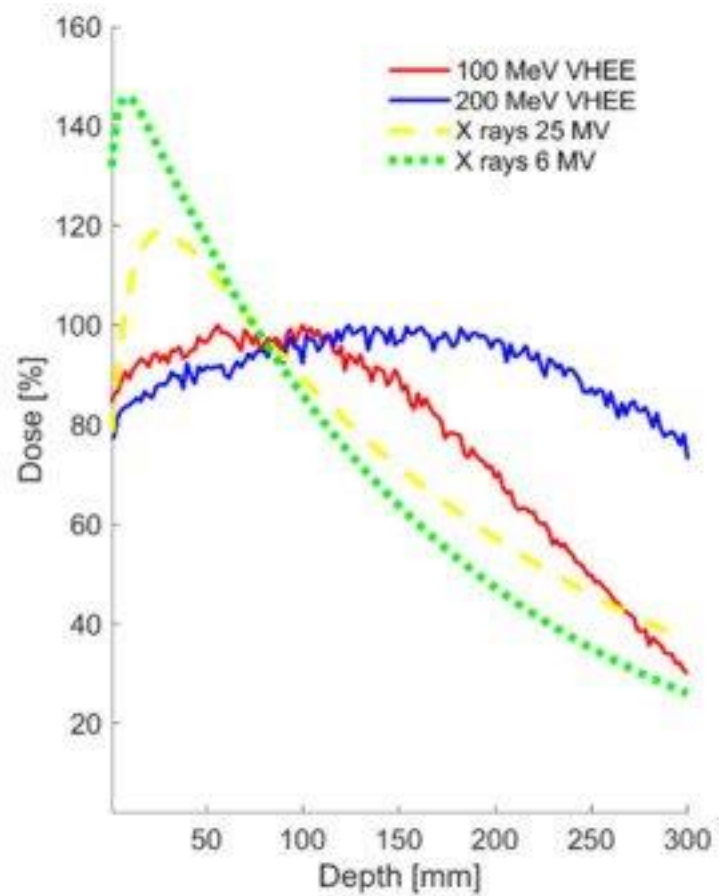


Fig. 1. Temporal evolution of the treated lesion: (a) before treatment; the limits of the PTV are delineated in black; (b) at 3 weeks, at the peak of skin reactions (grade 1 epithelitis NCI-CTCAE v 5.0); (c) at 5 months.

First human patient – skin cancer treated with 10 MeV-range electrons

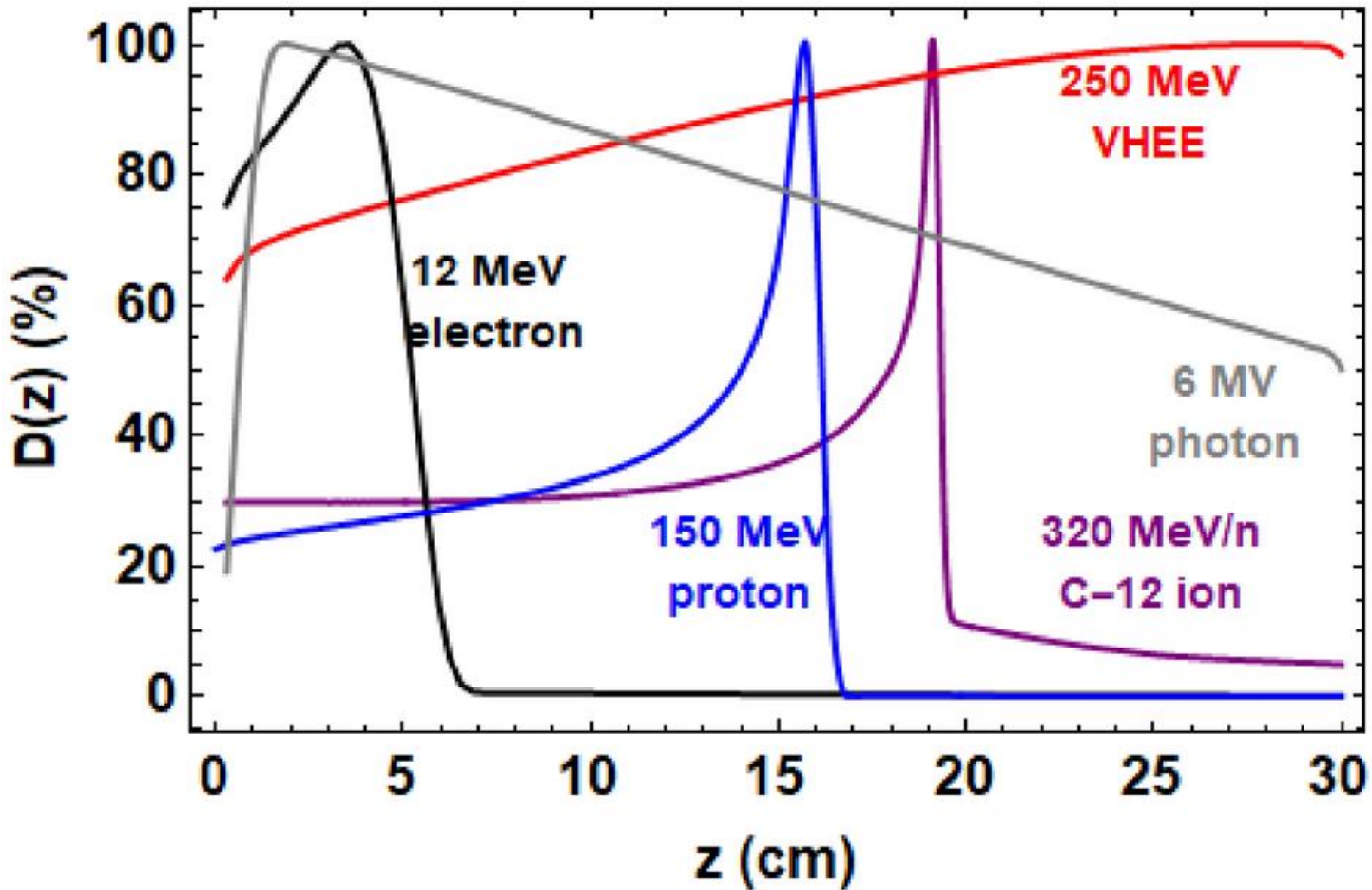


(a)



(b)

<https://www.mdpi.com/2072-6694/13/19/4942/htm>



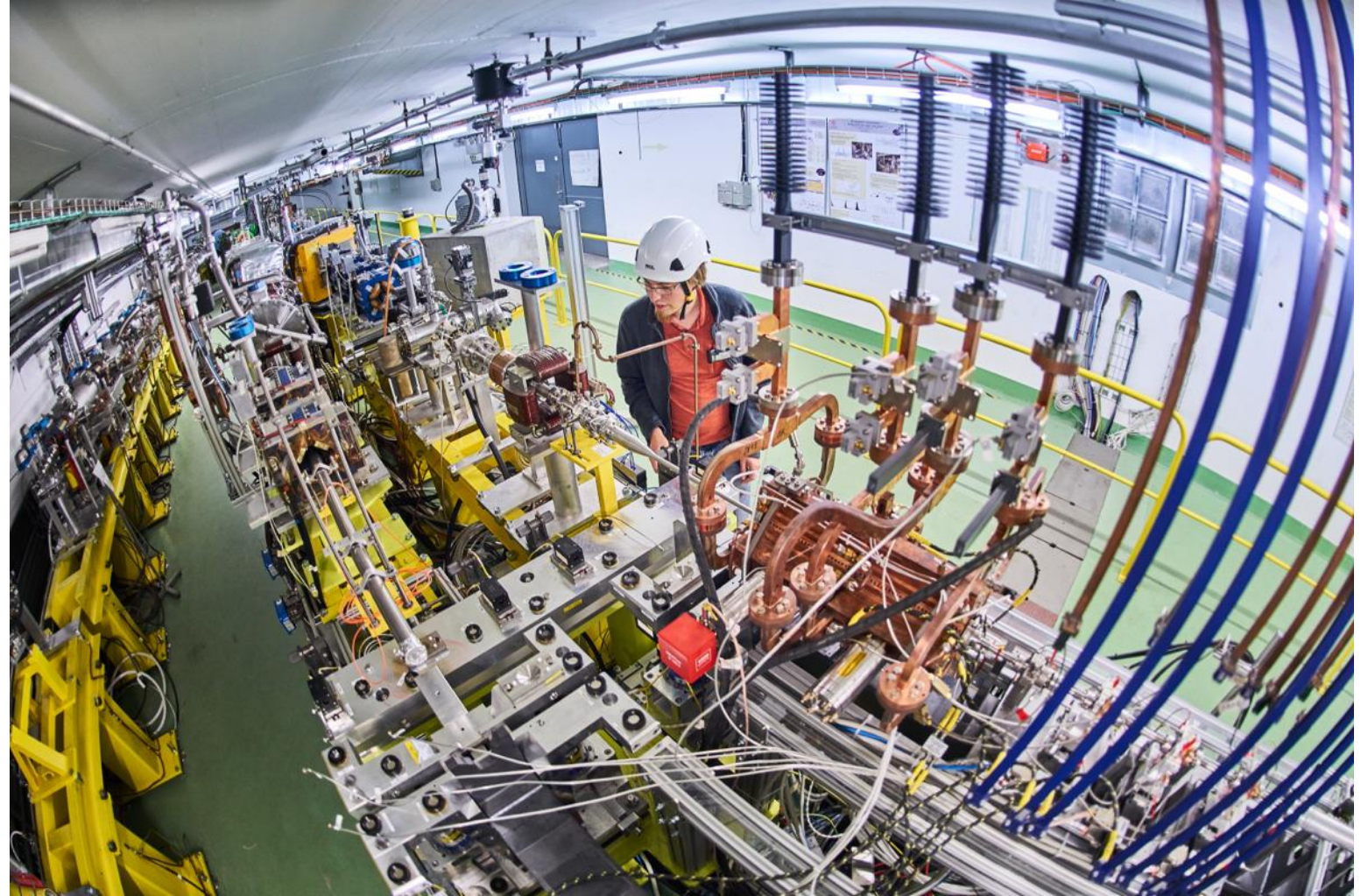
TOPAS-based Monte Carlo simulations of the integrated normalised dose deposited in the plane parallel to the direction of an incident Gaussian beam ( $\sigma=4\text{mm}$ ). All beams are in the absence of focusing

<https://www.nature.com/articles/s41598-021-93276-8#Fig1>



# The CERN Linear Electron Accelerator for Research (CLEAR)

CLEAR is a versatile 200 MeV electron linac + a 20m experimental beamline, operated at CERN as a multi-purpose user facility.



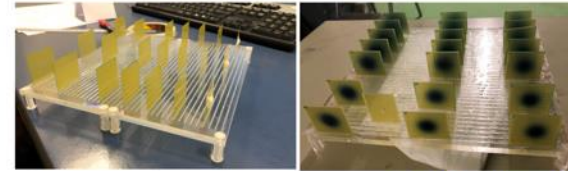
# VHEE activities in CLEAR

Calibration of operational medical dosimeters  
– nonlinear effects with high-dose short pulses

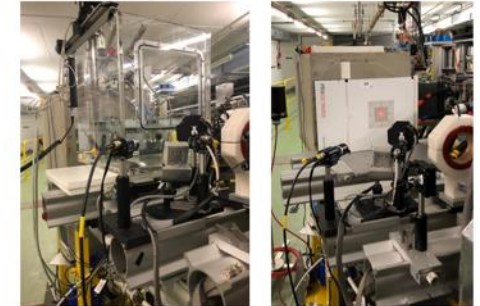
Verification of FLASH effect using biological dosimeters

Experimental verification of dose deposition profiles in water phantoms

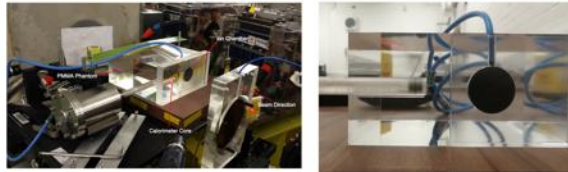
Demonstration of “Bragg-like peak” deposition with focused beams



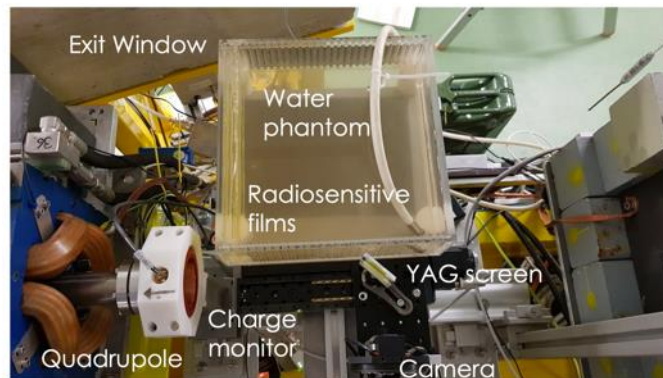
Films set-up for profile depth dose, CHUV Lausanne (M.C. Vozenin, C. Bailat, R. Moeckli et al.)



Advance Markus chambers and SRS Array, Oldenburg University and PTW (B. Poppe, D. Poppinga et al.)



Calorimeter and ROOS chamber, Nat. Phys. Lab. UK (A. Subiel et al.)



Strathclyde and Manchester

A. Lagdza, R. Jones et al., Influence of heterogeneous media on Very High Energy Electron (VHEE) dose penetration and a Monte Carlo-based comparison with existing radiotherapy modalities, Nuclear Inst. and Meth. in Physics Research, B, 482 (2020) 70-81.

M. McManus, A. Subiel et al., The challenge of ionisation chamber dosimetry in ultra-short pulsed high dose-rate Very High Energy Electron beams, Nature Scientific Reports (2020) 10-9089.

Small, K.L., Henthorn, et al., Evaluating very high energy electron RBE from nanodosimetric pBR322 plasmid DNA damage, Nature Sci. Rep. 11, 3341 (2021).

D. Poppinga et al., VHEE beam dosimetry at CERN Linear Electron Accelerator for Research under ultra-high dose rate conditions, 2021 Biomed. Phys. Eng. Express 7 015012.

Kokurewicz, K., Brunetti, E., Curcio, A. et al. An experimental study of focused very high energy electron beams for radiotherapy, Nature Commun. Phys. 4, 33 (2021).

**Table 1.** Main parameters for the VHEE sources cited in this document.

Beam Parameters	CLEAR	SPARC	NLCTA
Energy (MeV)	50–220	170	50–120
Bunch charge (pC/shot)	150	60	30
Bunch length rms (ps)	0.1–10	0.87	1
Repetition rate (Hz)	0.8–10	0.1–10	0.1–10
Beam size at water phantom surface ( $\sigma$ mm)	1.2	3.4	2

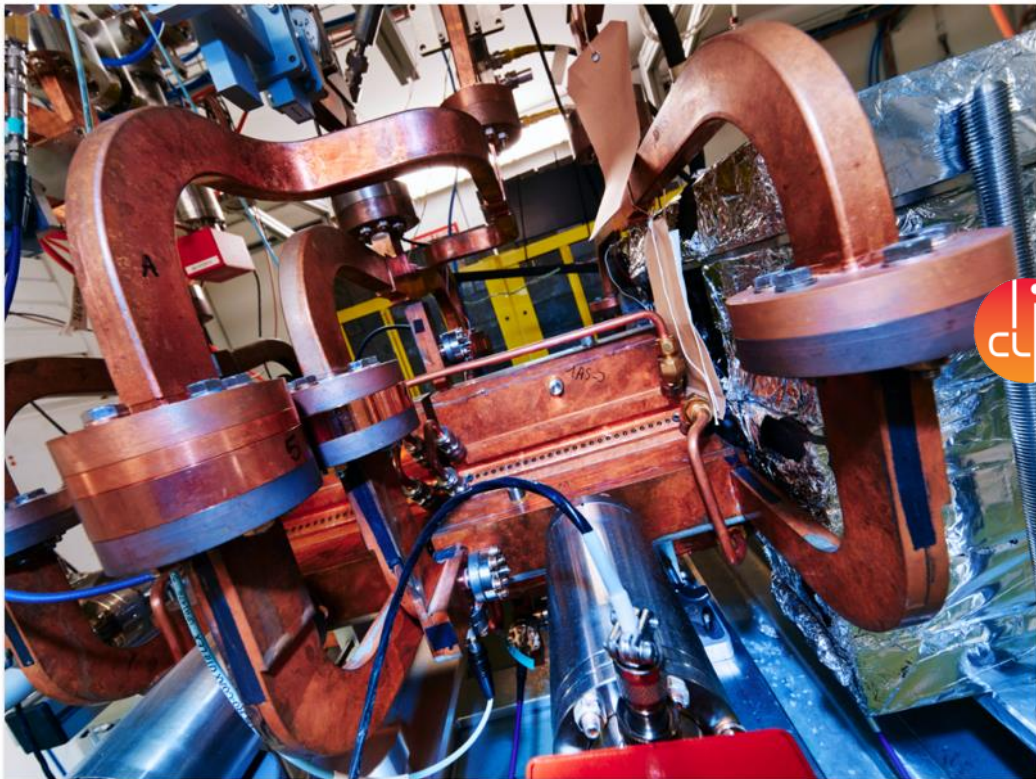
**Table 2.** List of facilities or accelerators under development for VHEE production.

Beam Parameters	PHASER	CLARA	PITZ	Argonne	Tsinghua University
Energy (MeV)	100–200	50 (–250)	20 (–250)	6–63	45 (–350)
Bunch charge (pC/shot)	-	20–100	0.1–5000	100–10 <sup>5</sup>	200
Bunch length rms (ps)	3.10 <sup>5</sup>	0.3–5	30	0.3	<2
Repetition rate (Hz)	10	10 (–100)	10	0.5–10	5–50

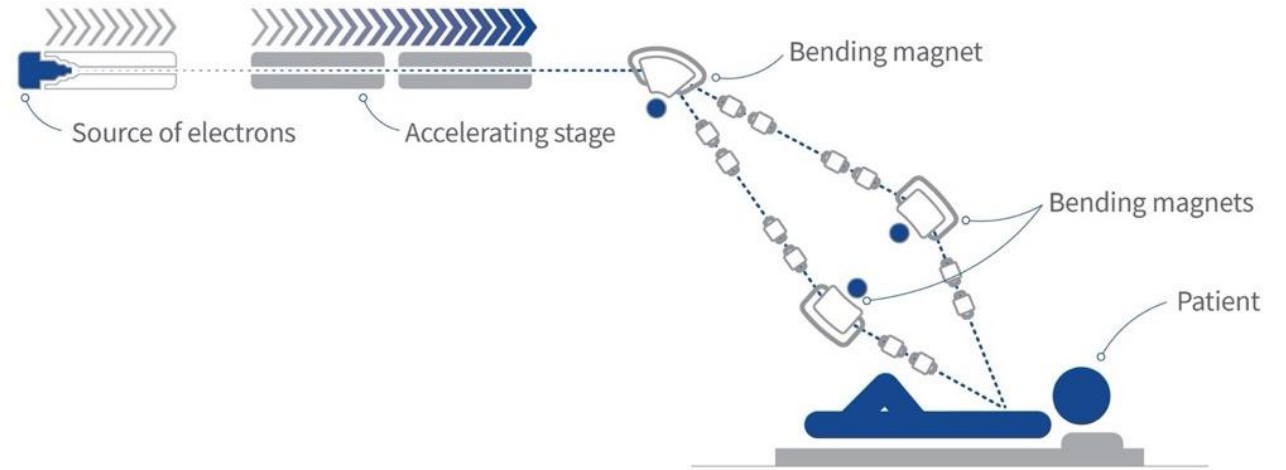
<https://www.mdpi.com/2072-6694/13/19/4942/htm>

# FLASH VHEE therapy

CLIC technology for a FLASH VHEE facility designed by CERN in collaboration with CHUV that will be realized by THERYQ



Close-up of the Compact Linear Collider prototype, on which the electron FLASH design is based (Image: CERN)



An intense beam of electrons is produced in a photoinjector, accelerated to around 100 MeV and then is expanded, shaped and guided to the patient.

The design of this facility is the result of an intense dialogue between groups at CHUV and CERN.

Jean Bourhis from CHUV:  
“The clinical need that we have really converges with the technological answer that CERN has.”

# The remarkable connection between CLIC technology and FLASH electron therapy

## Very intense electron beams

CLIC – to provide brightness needed for delicate physics experiments

FLASH – to provide dose fast for biological FLASH effect

## Very precisely controlled electron beams

CLIC – to reduce the power consumption of the facility

FLASH – to provide reliable treatment in a clinical setting

## High accelerating gradient (that is high beam energy gain per length)

CLIC – fit facility in Lac Lemman region and limit cost

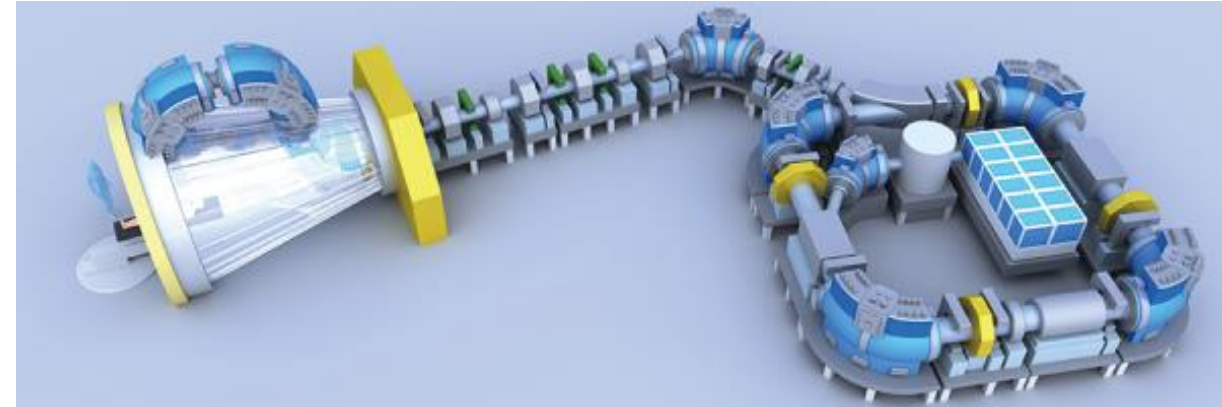
FLASH – fit facility on typical hospital campuses and limit cost of treatment



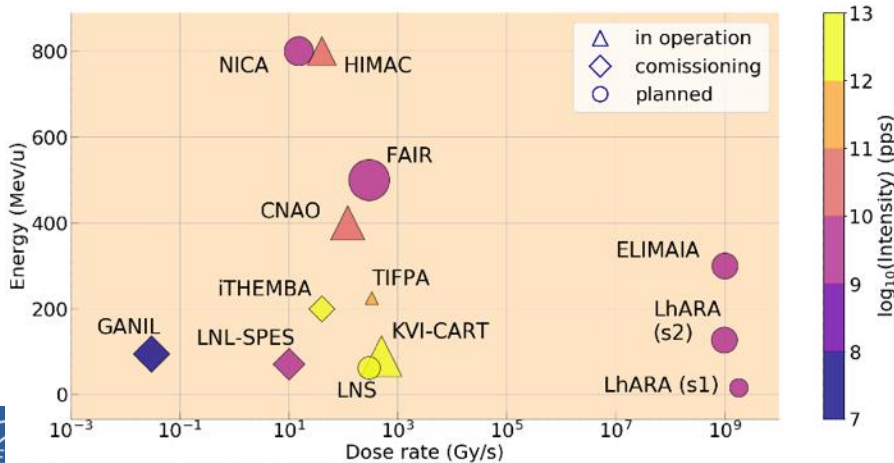
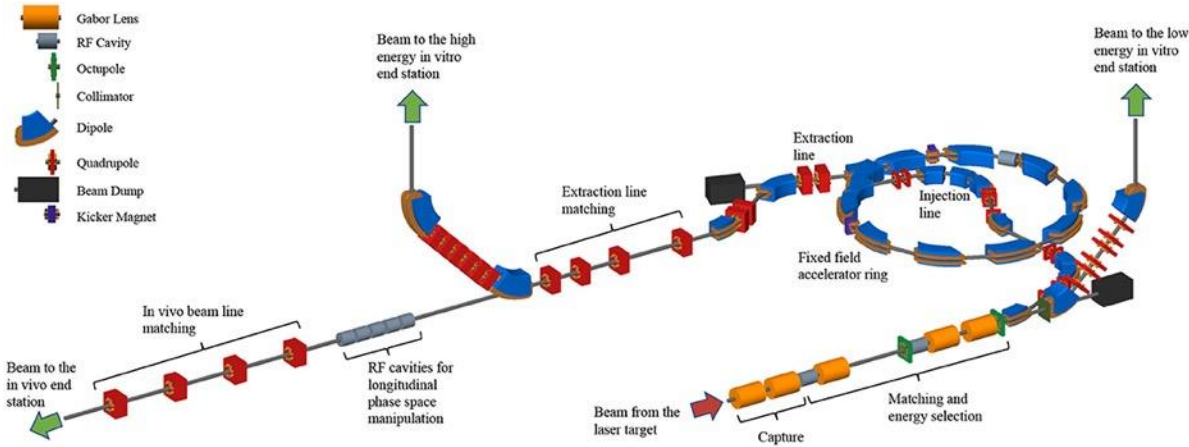
CERN KT Seminar on April 26<sup>th</sup>, 2021  
<https://indico.cern.ch/event/975980/>

# Look even further

## Quantum Scalpel



## Laser-hybrid Accelerator for Radiobiological Applications



Credit: LhARA Consortium

5th generation facility:

Superconducting synchrotron

Multi-ion irradiation system

Injector with laser acceleration technology

Rotating gantry with HTS magnets

Microsurgery system



# End part I

Photo: CNAO treatment room

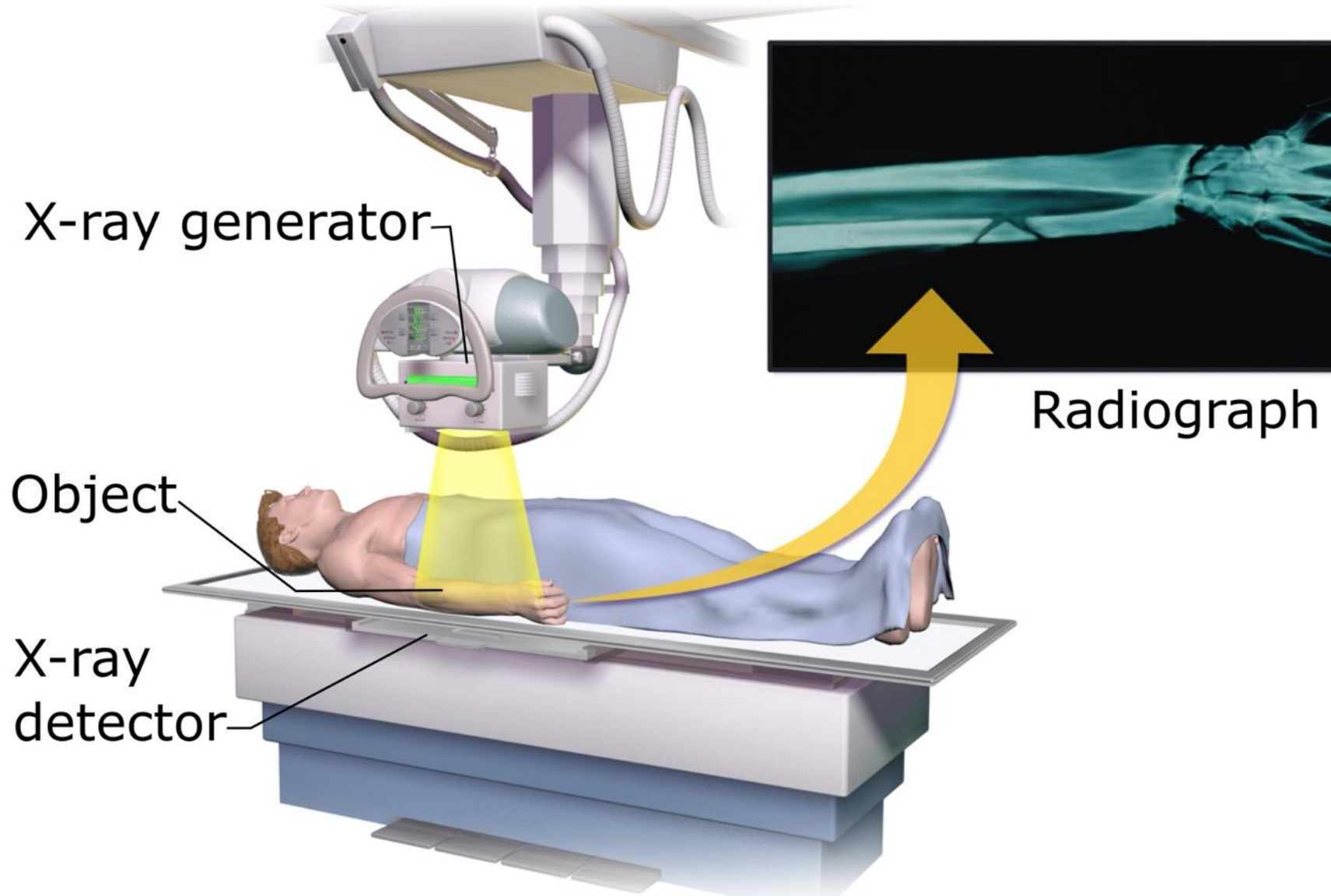


# X RAYS



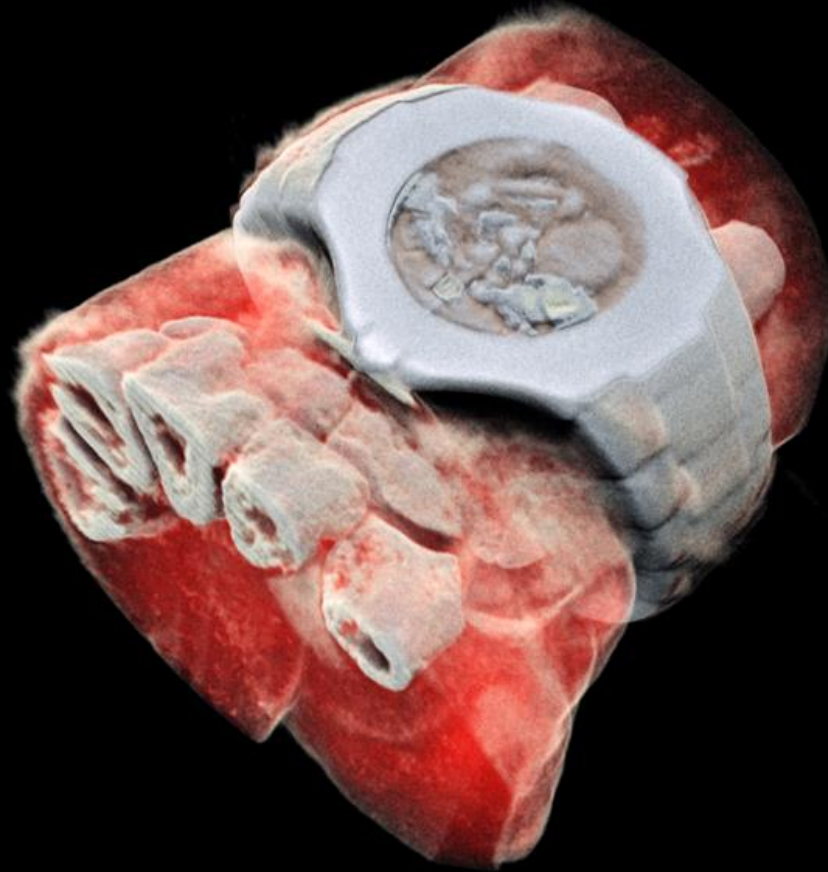


# Projectional radiography



[https://en.wikipedia.org/wiki/X-ray\\_detector#/media/File:Projectional\\_radiography\\_components.jpg](https://en.wikipedia.org/wiki/X-ray_detector#/media/File:Projectional_radiography_components.jpg)  
Blausen Medical Annotations by Mikael Haggström - By Blaussen Medical.  
<https://creativecommons.org/licenses/by-sa/4.0/>


# Fast forward to 2018



First 3D colour X-ray of human extremities using the Medipix3 technology developed at CERN

# Medipix

A family of pixel detector read-out chips for particle imaging and detection developed by the Medipix Collaborations



A photograph of a Medipix1 chip, showing a long, narrow array of colorful pixels (red, green, blue, purple) on a dark substrate, with a gold-colored edge connector.

## Medipix1 Collaboration

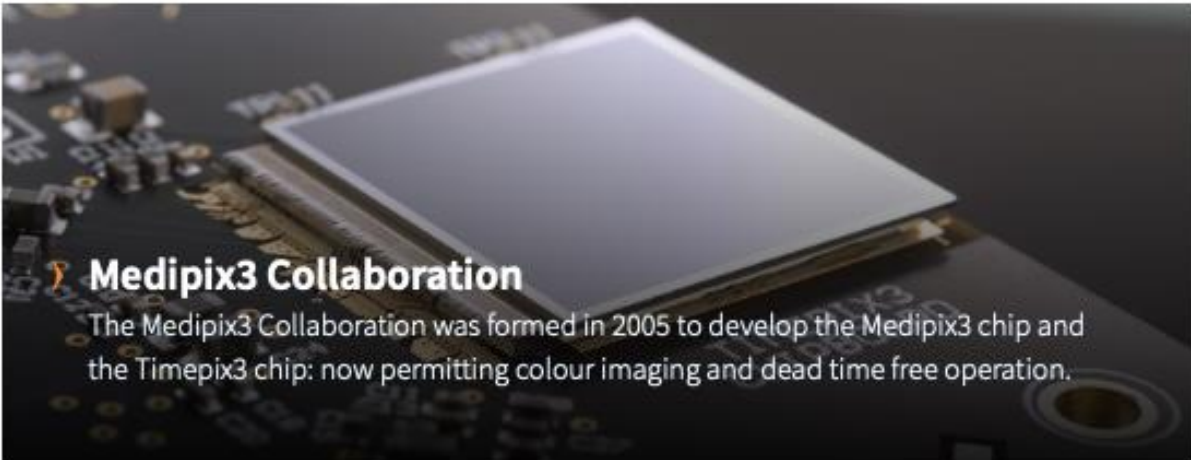
The Medipix1 collaboration was formed in the 1990's when the potential of the new technology to provide noise-free single-photon counting was demonstrated.



A photograph of a Medipix2 probe card, showing a square chip mounted on a green PCB with various components and labels like 'IC1', 'C10', 'C15', 'C16', 'C11', 'C12', 'C13', 'C14', 'IC2', 'IC3', 'IC4', 'IC5', 'IC6', 'IC7', 'IC8', 'IC9', 'IC10', 'IC11', 'IC12', 'IC13', 'IC14', 'IC15', 'IC16', 'IC17', 'IC18', 'IC19', 'IC20', 'IC21', 'IC22', 'IC23', 'IC24', 'IC25', 'IC26', 'IC27', 'IC28', 'IC29', 'IC30', 'IC31', 'IC32', 'IC33', 'IC34', 'IC35', 'IC36', 'IC37', 'IC38', 'IC39', 'IC40', 'IC41', 'IC42', 'IC43', 'IC44', 'IC45', 'IC46', 'IC47', 'IC48', 'IC49', 'IC50', 'IC51', 'IC52', 'IC53', 'IC54', 'IC55', 'IC56', 'IC57', 'IC58', 'IC59', 'IC60', 'IC61', 'IC62', 'IC63', 'IC64', 'IC65', 'IC66', 'IC67', 'IC68', 'IC69', 'IC70', 'IC71', 'IC72', 'IC73', 'IC74', 'IC75', 'IC76', 'IC77', 'IC78', 'IC79', 'IC80', 'IC81', 'IC82', 'IC83', 'IC84', 'IC85', 'IC86', 'IC87', 'IC88', 'IC89', 'IC90', 'IC91', 'IC92', 'IC93', 'IC94', 'IC95', 'IC96', 'IC97', 'IC98', 'IC99', 'IC100'. The text 'MEDIPIX PROBE CARD' is visible on the board.

## Medipix2 Collaboration


The Medipix2 Collaboration was formed in 1999 with the aim of developing a single photon counting pixel detector readout chip using a 0.25  $\mu\text{m}$  CMOS process.



A photograph of a Medipix3 chip, showing a square, white, square-shaped chip mounted on a dark PCB with gold-colored edge connectors.

## Medipix3 Collaboration

The Medipix3 Collaboration was formed in 2005 to develop the Medipix3 chip and the Timepix3 chip: now permitting colour imaging and dead time free operation.

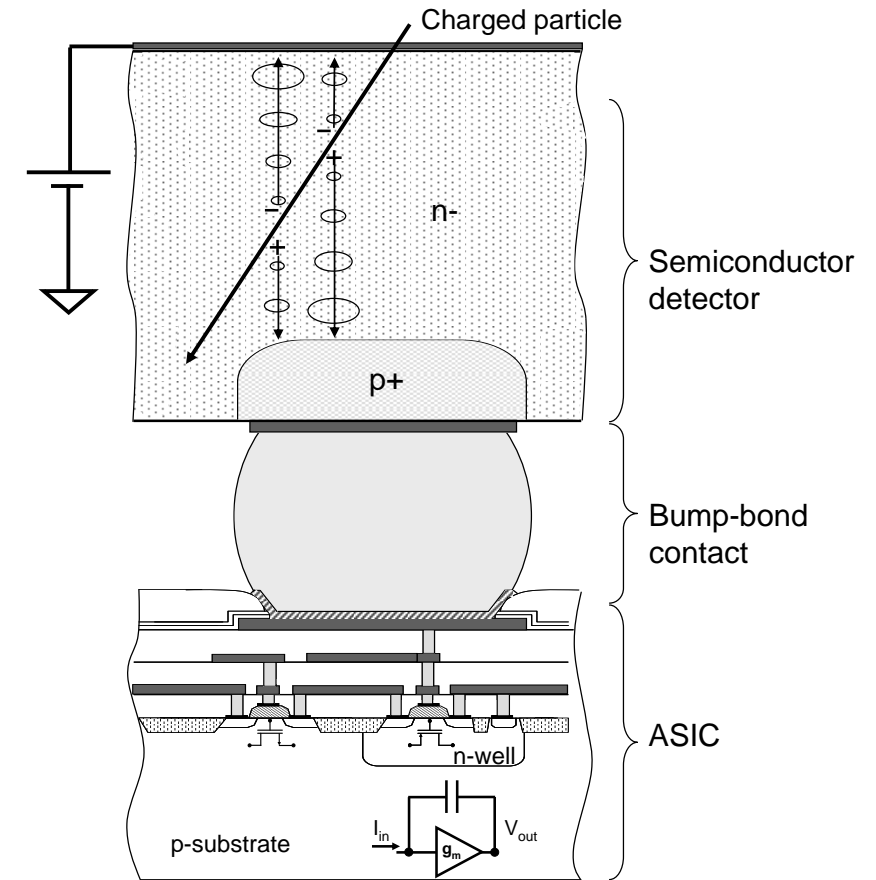
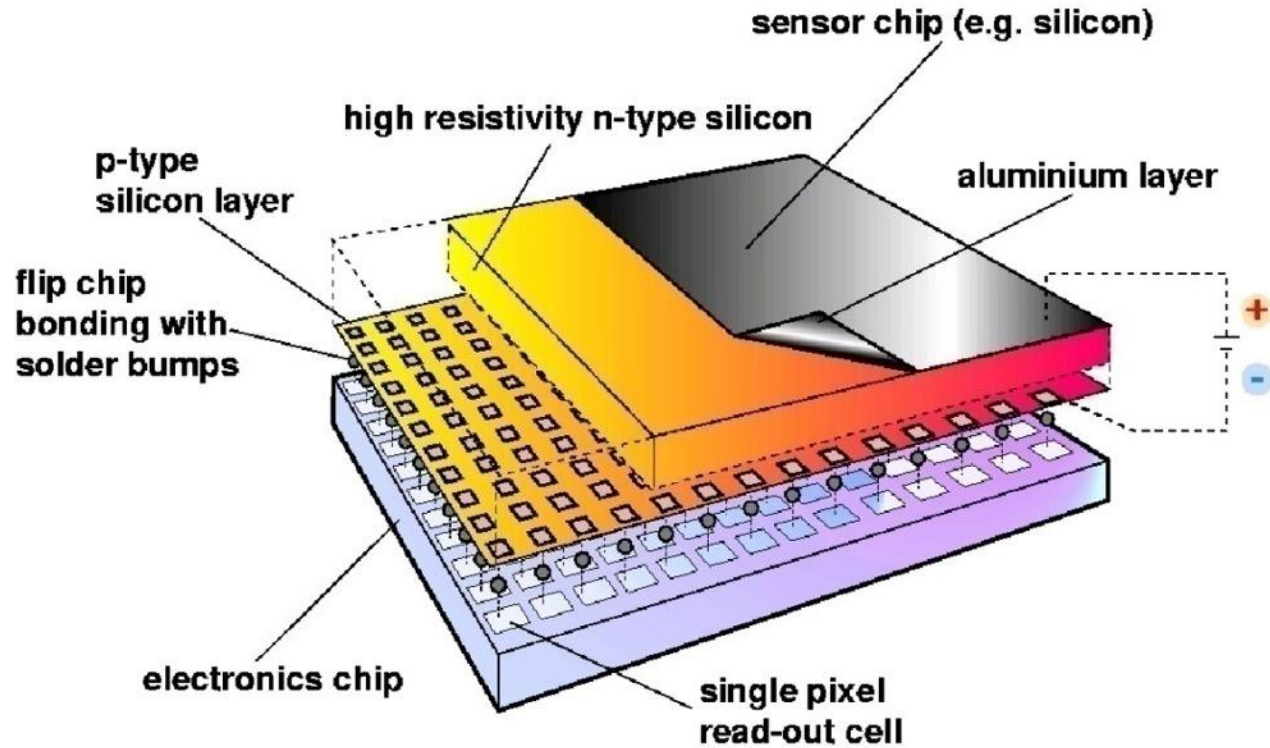
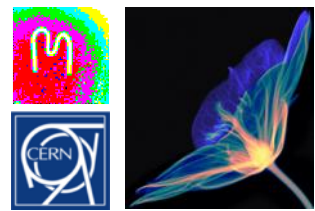


A photograph of two Medipix4 chips, one purple and one red, mounted on a dark PCB with gold-colored edge connectors.

## Medipix4 Collaboration

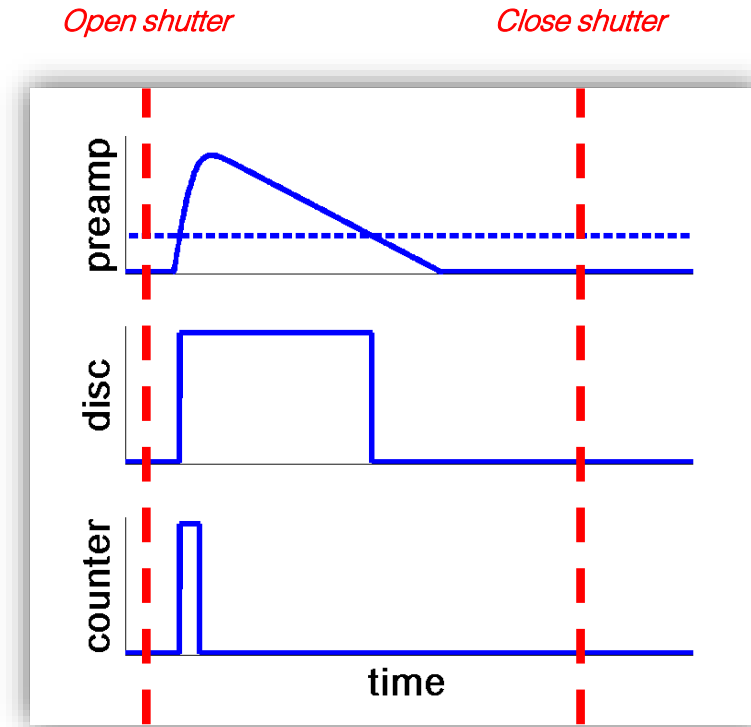
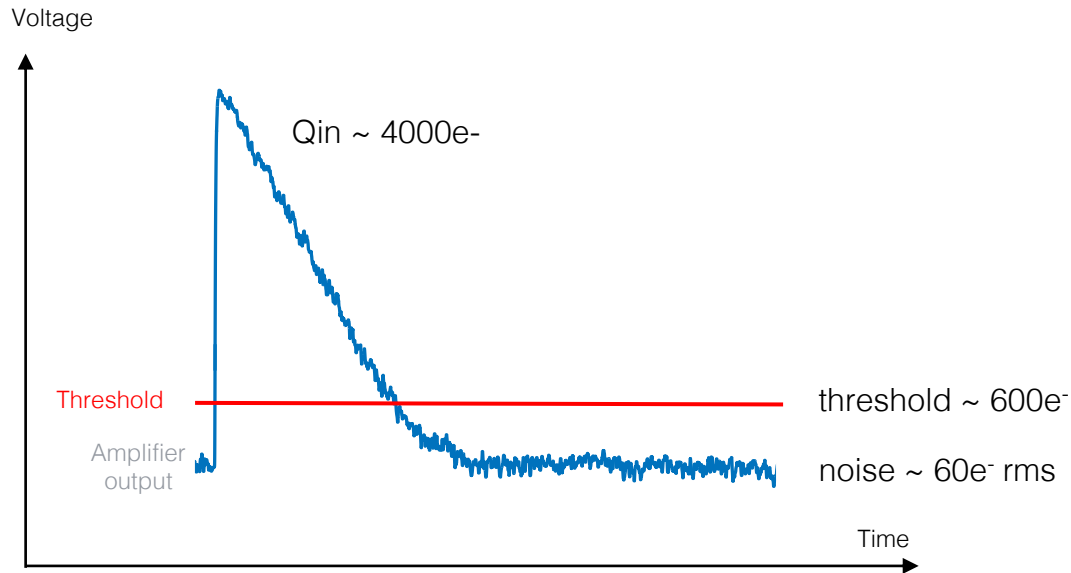
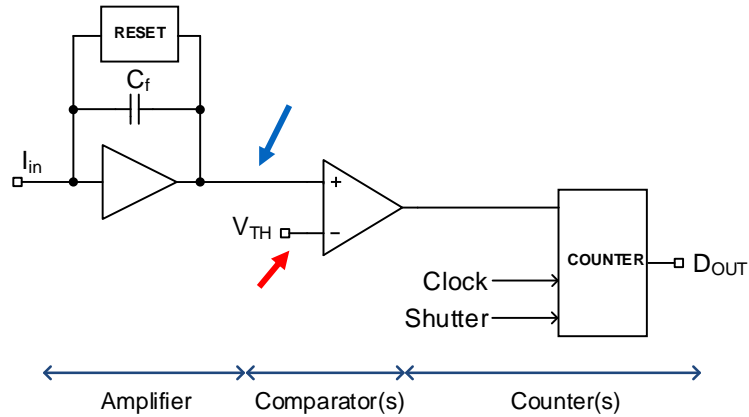
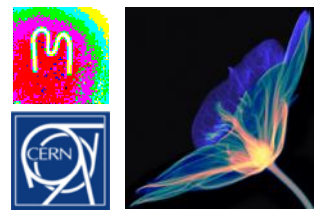
The Medipix4 Collaboration was launched in 2017. The aim is designing pixel read-out chips fully prepared for TSV processing that may be tiled on all four sides.

# Hybrid Silicon Pixel Detectors



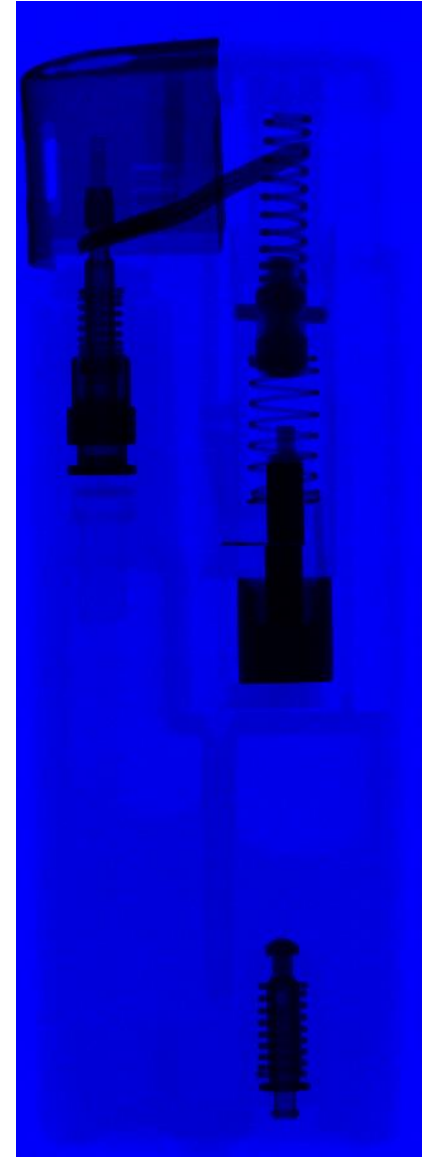
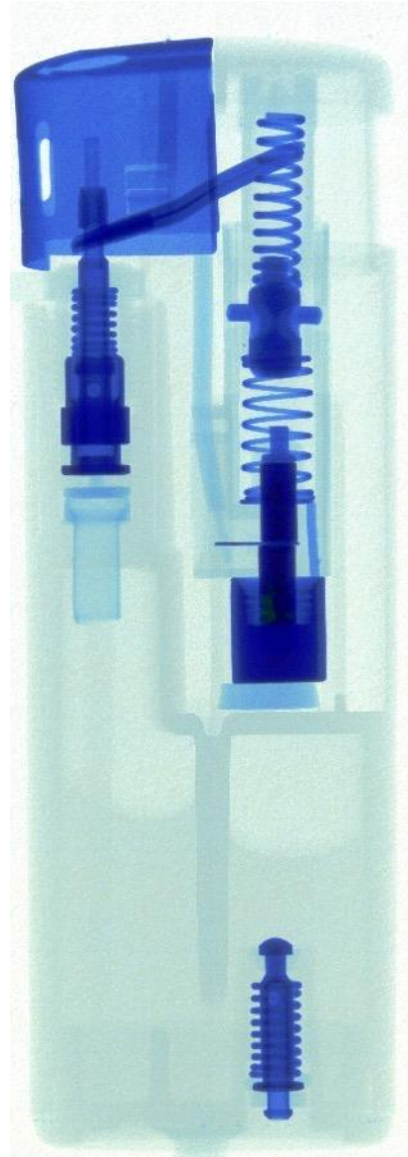
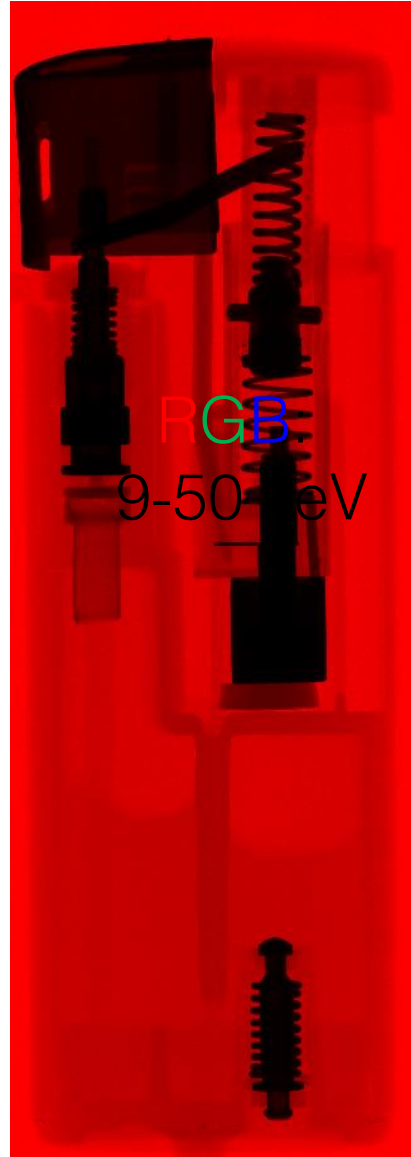
Noise-hit free particle detection  
 Standard CMOS can be used allowing on-pixel signal processing  
 Sensor material can be changed (Si, GaAs, CdTe..)

# Hybrid Silicon Pixel Detectors: counting electronics



→ Noise hit free imaging

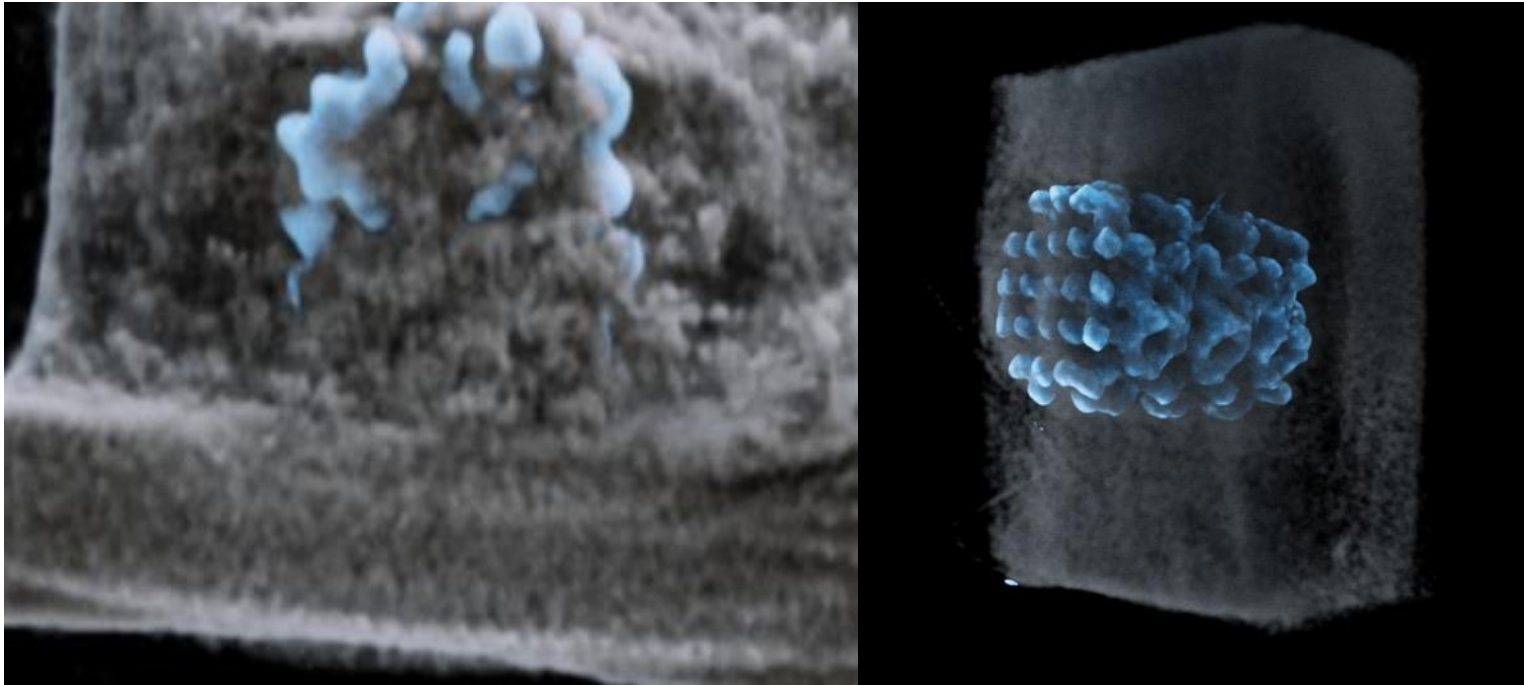
# Colour x-ray of a lighter



S. Procz et al.

# Spectral imaging of Joints

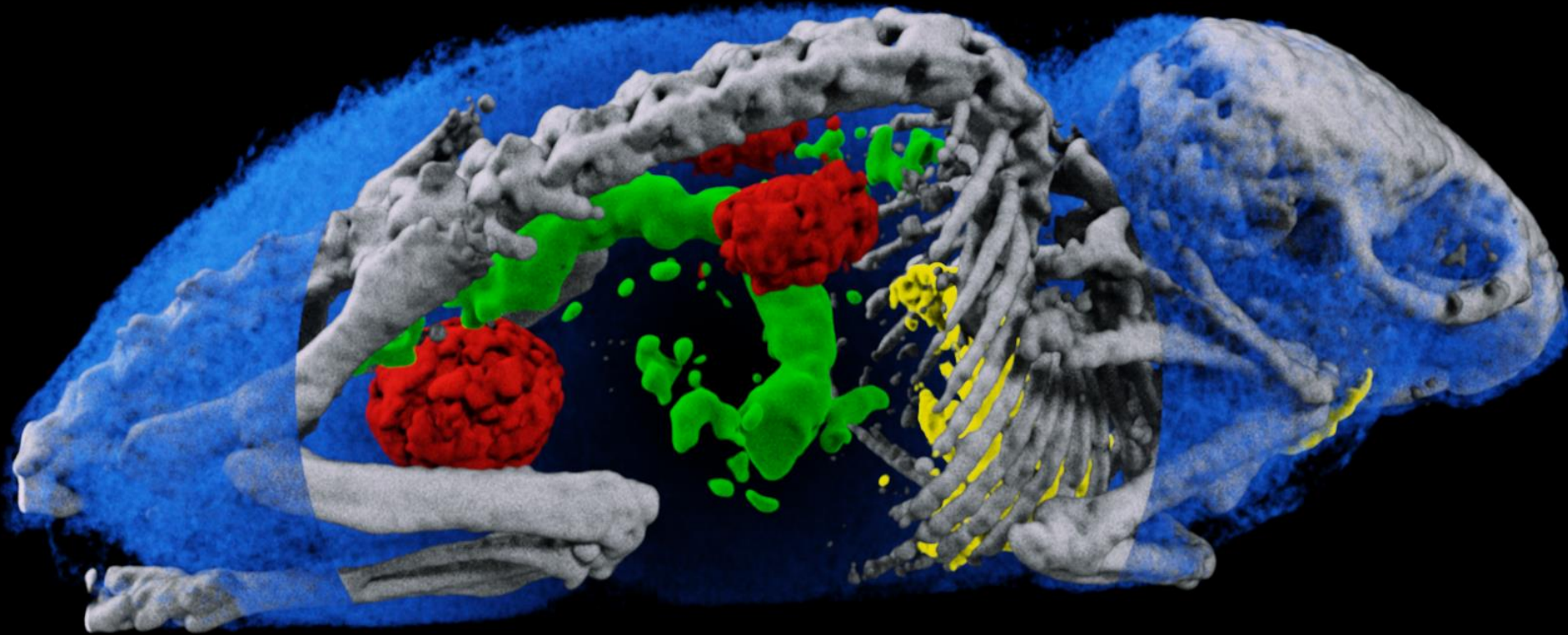
Titanium implant in sheep bone



Enables better understanding of

- process of bone ingrowth
- bone / implant interface

# Spectroscopic information permits material separation



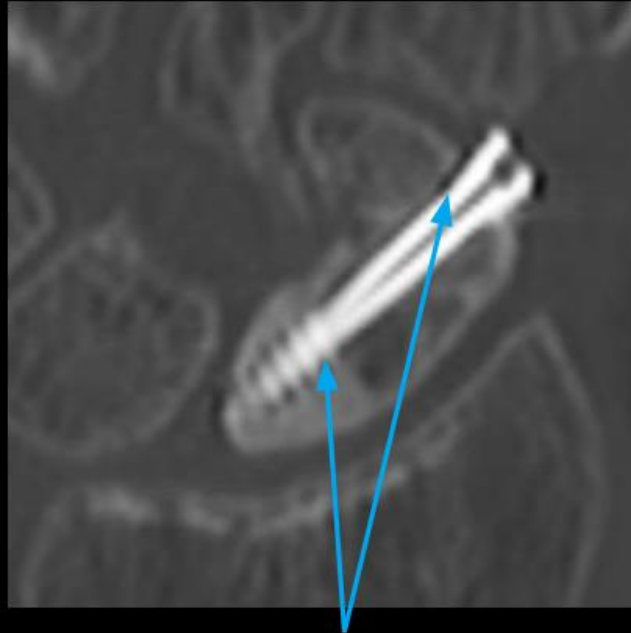
The water has been partly cut away to reveal the bone, gold, gadolinium and iodine

Images presented and the European Congress of Radiology, Vienna, March 2017.



# CT versus MARS

Standard CT

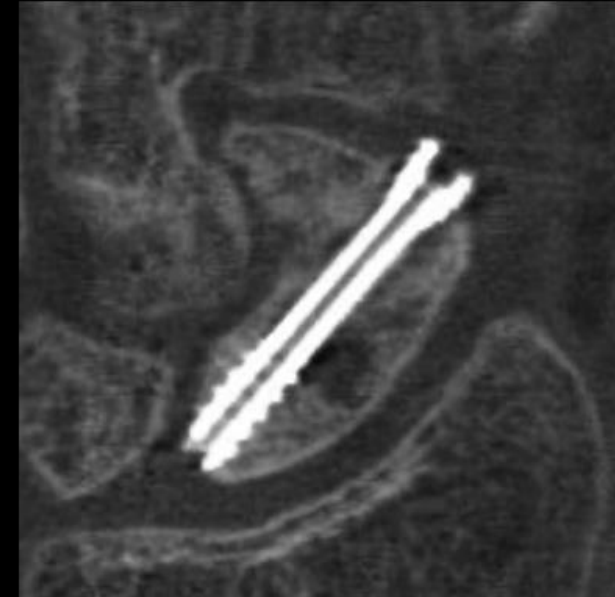


*Metal artifact hides the bone-metal interface*

Metal artefact

Scaphoid screw

MARS



*The bone-metal interface is visualised enabling assessment of peri-implant infection and osteolysis*

MARS SPCCT Imaging technology is in concept development for human use. It is not a product and is not cleared or approved by the US FDA or any other regulator for commercial availability outside of New Zealand

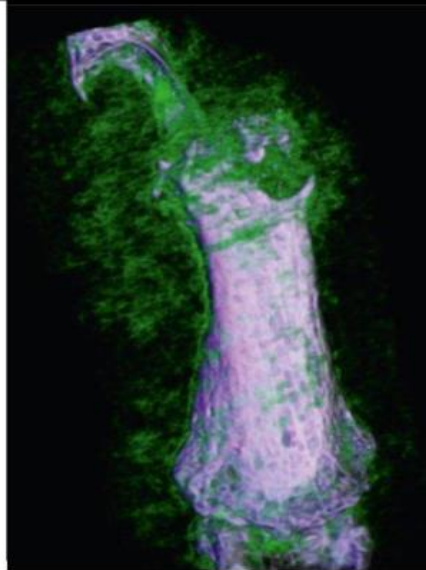


Slide courtesy of Anthony Butler, University of Canterbury

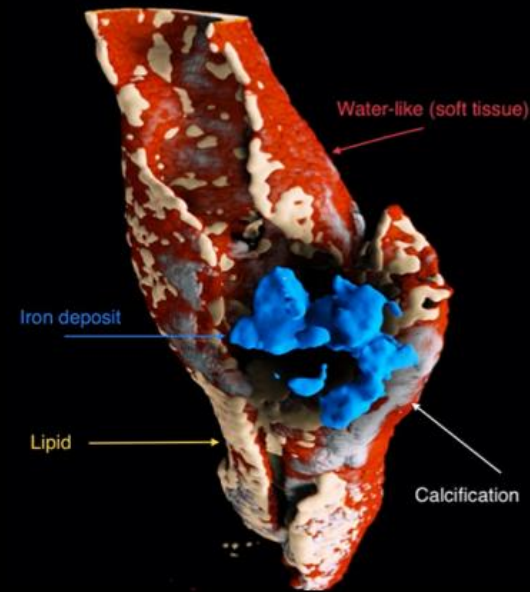
Presented at 6th Workshop on Medical Applications of Spectroscopic X-ray Detectors, 29 Aug 2022, CERN

# Molecular versus MARS

## MARS - intrinsic information



Gout crystal characterisation  
(Collab with CHUV)



Carotid plaque with quantitative measurements  
of fat, water, calcium, and iron

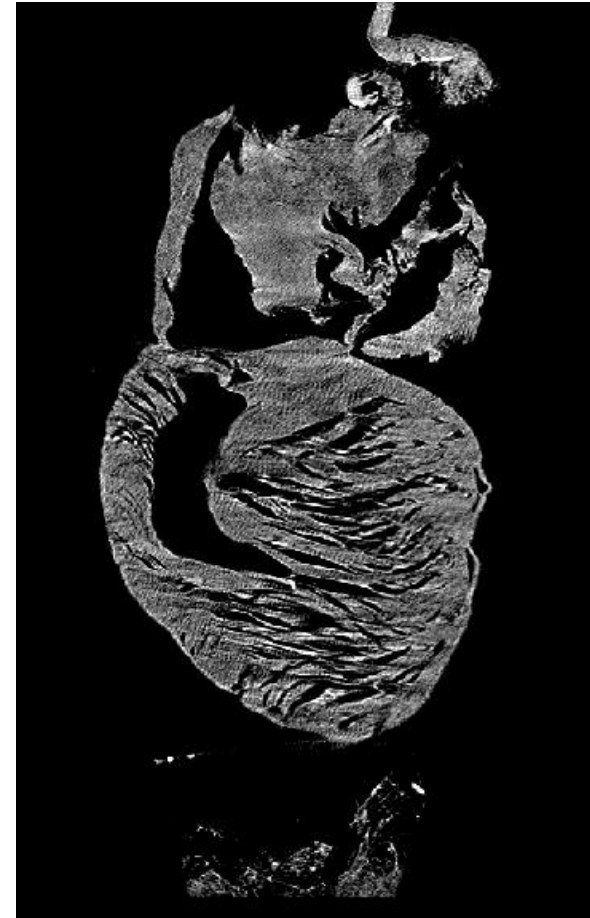
MARS SPCCT Imaging technology is in concept development for human use. It is not a product and is not cleared or approved by the US FDA or any other regulator for commercial availability outside of New Zealand



Slide courtesy of Anthony Butler, University of Canterbury

Presented at 6th Workshop on Medical Applications of Spectroscopic X-ray Detectors, 29 Aug 2022, CERN

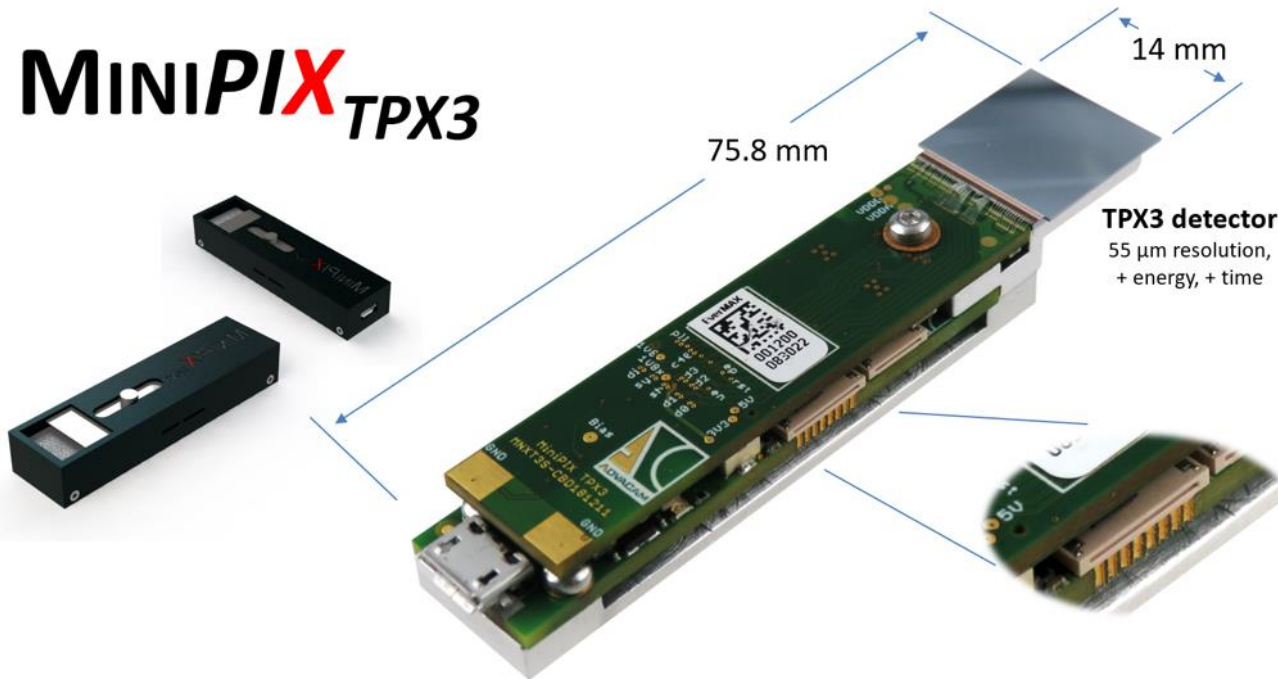




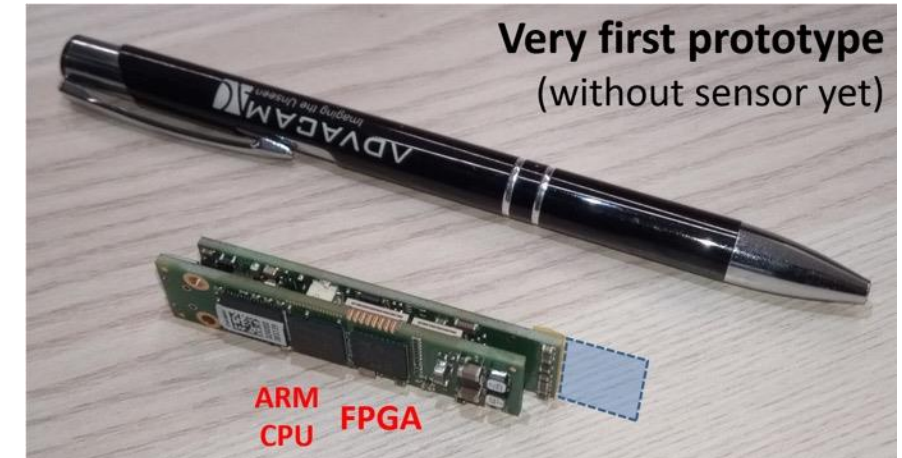
Ethanol-preserved mouse heart scanned using the WidePIX<sub>10x5</sub> detector  
60 kVp tungsten spectrum  
720 projections, 5 seconds per projection (one hours total)  
Spatial resolution ca. 7  $\mu$ m  
Reconstructed using Voxel, visualized using CTVox and Amide software

# MiniPIX TPX3

## Miniaturized spectral camera supporting Si and CdTe sensors

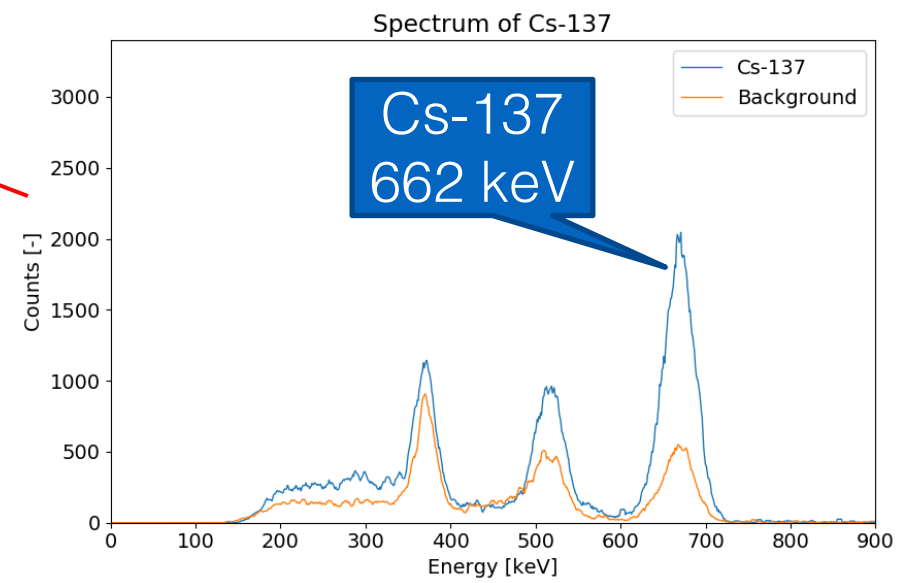
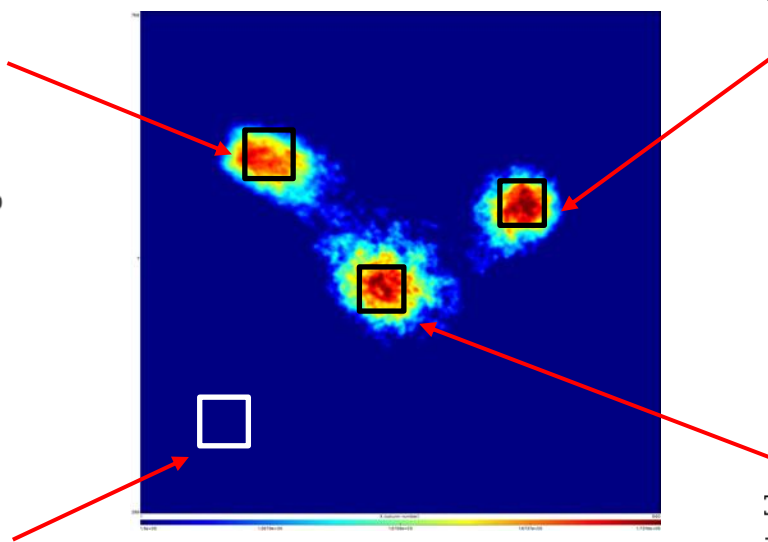
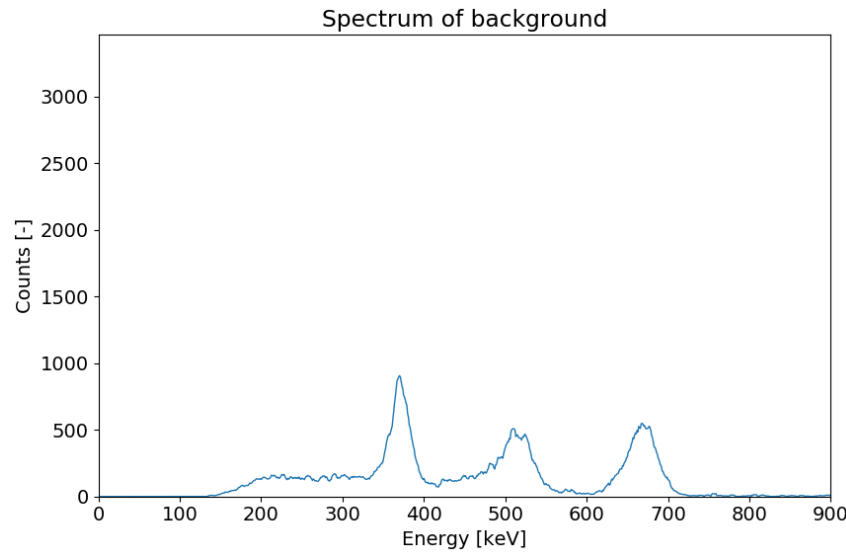
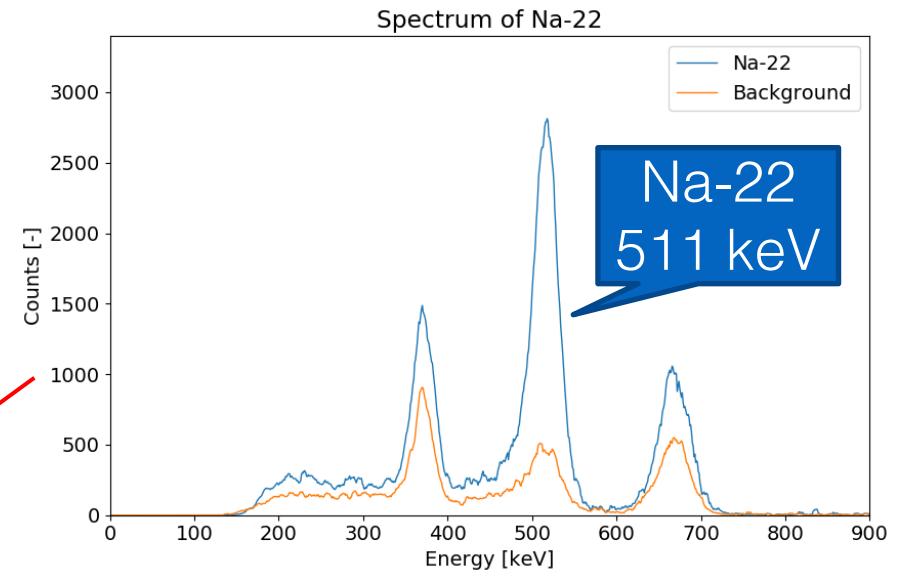
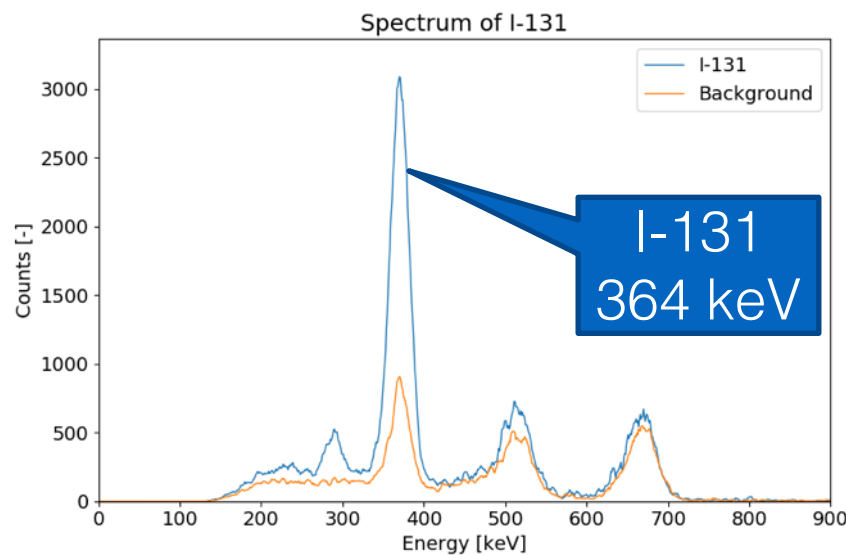


It's really small...



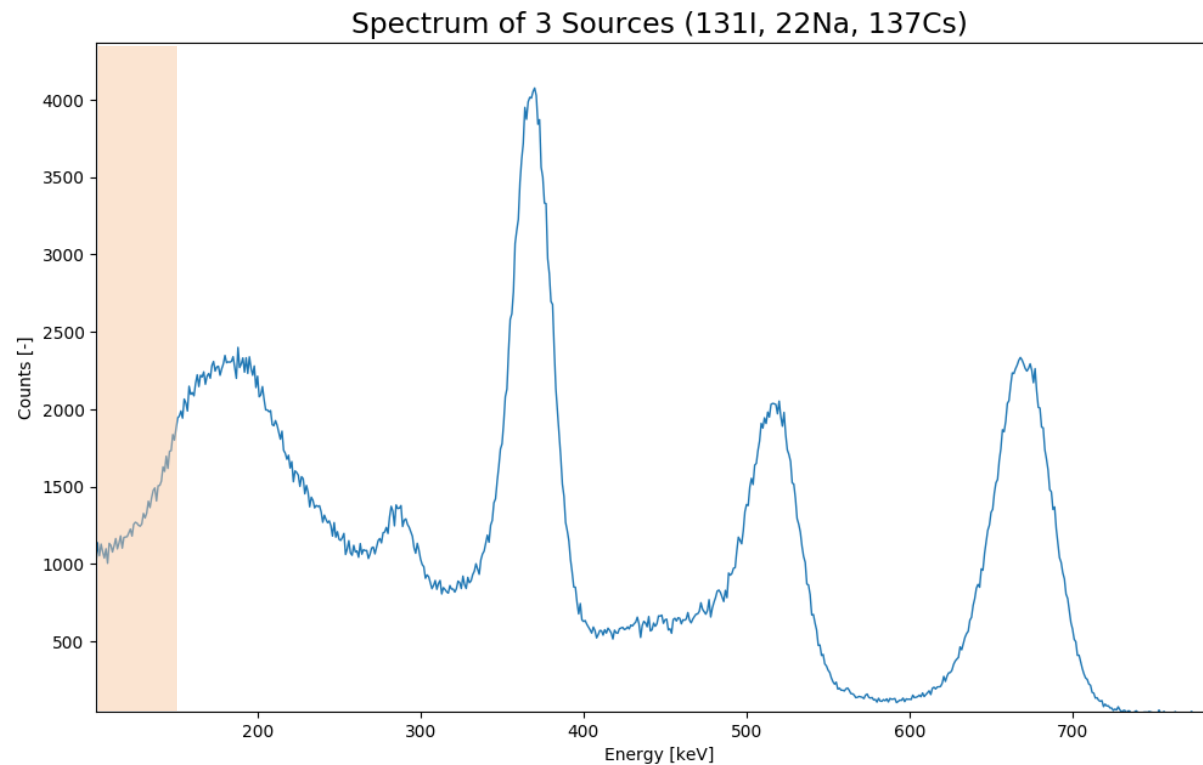
**ADVACAM**  
Imaging the Unseen

# Single Layer Compton Camera with MiniPIX TPX3 – Multiple Gamma Sources



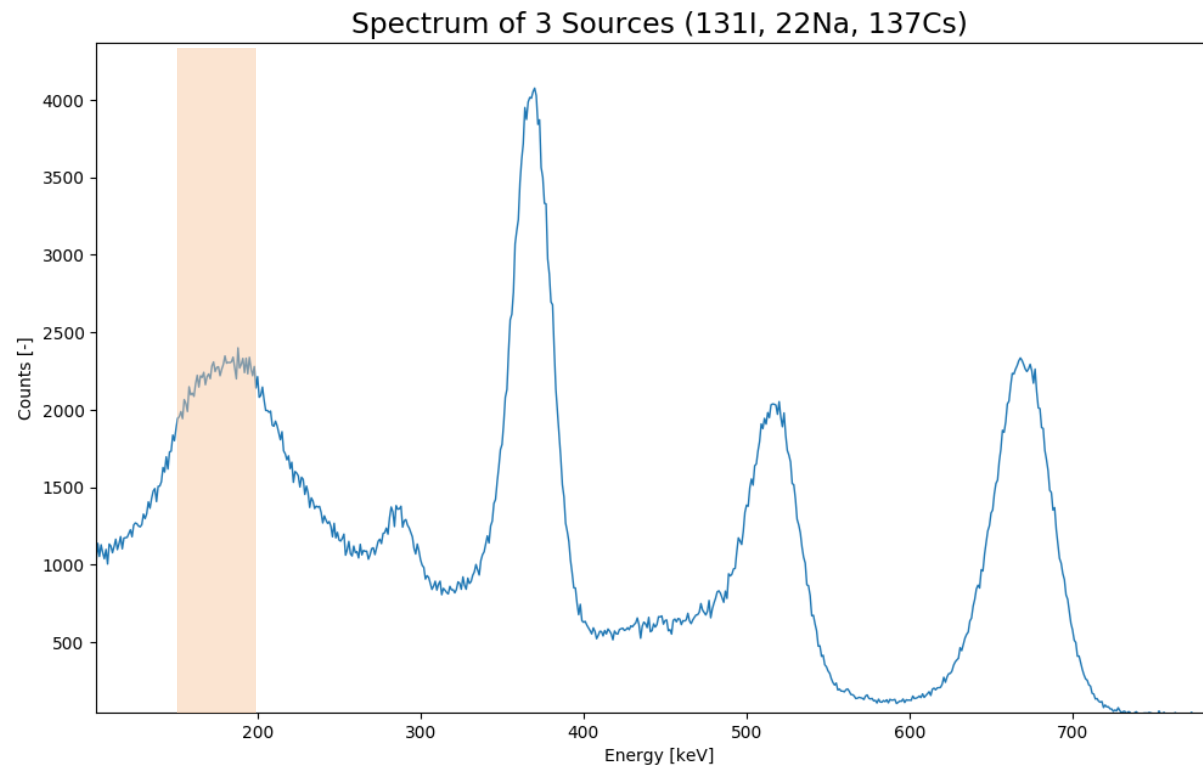
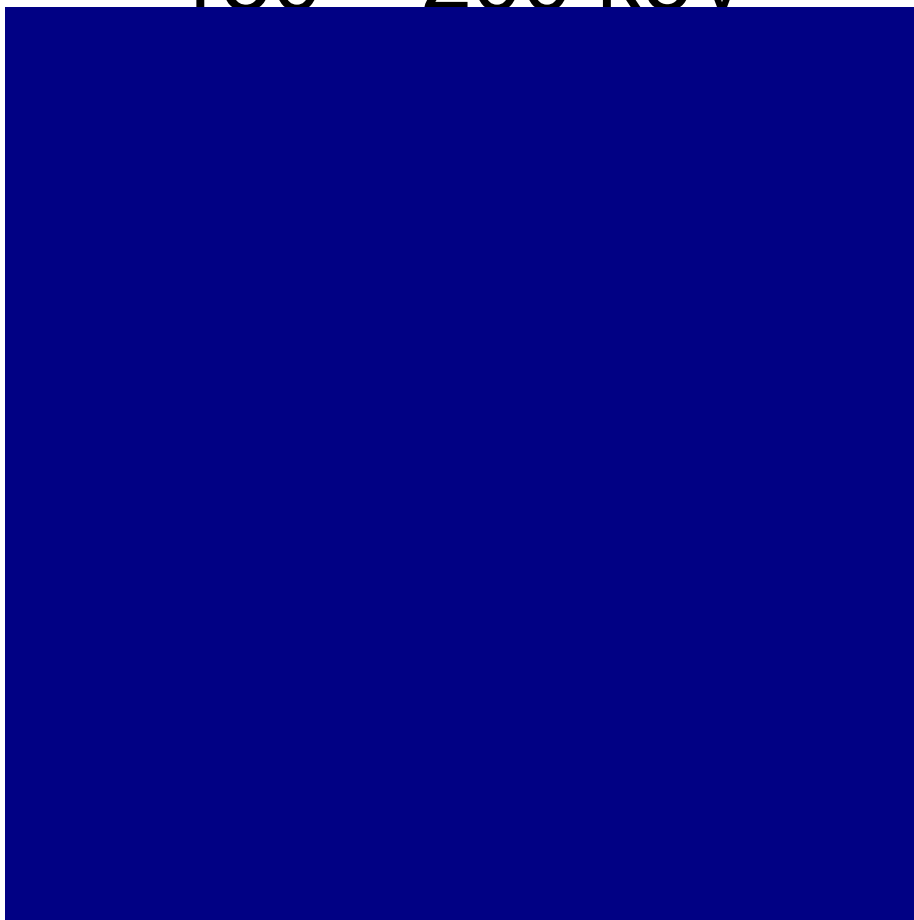
# Single Layer Compton Camera with MiniPIX TPX3 – Multiple Gamma Sources

100 – 150 keV



# Single Layer Compton Camera with MiniPIX TPX3 – Multiple Gamma Sources

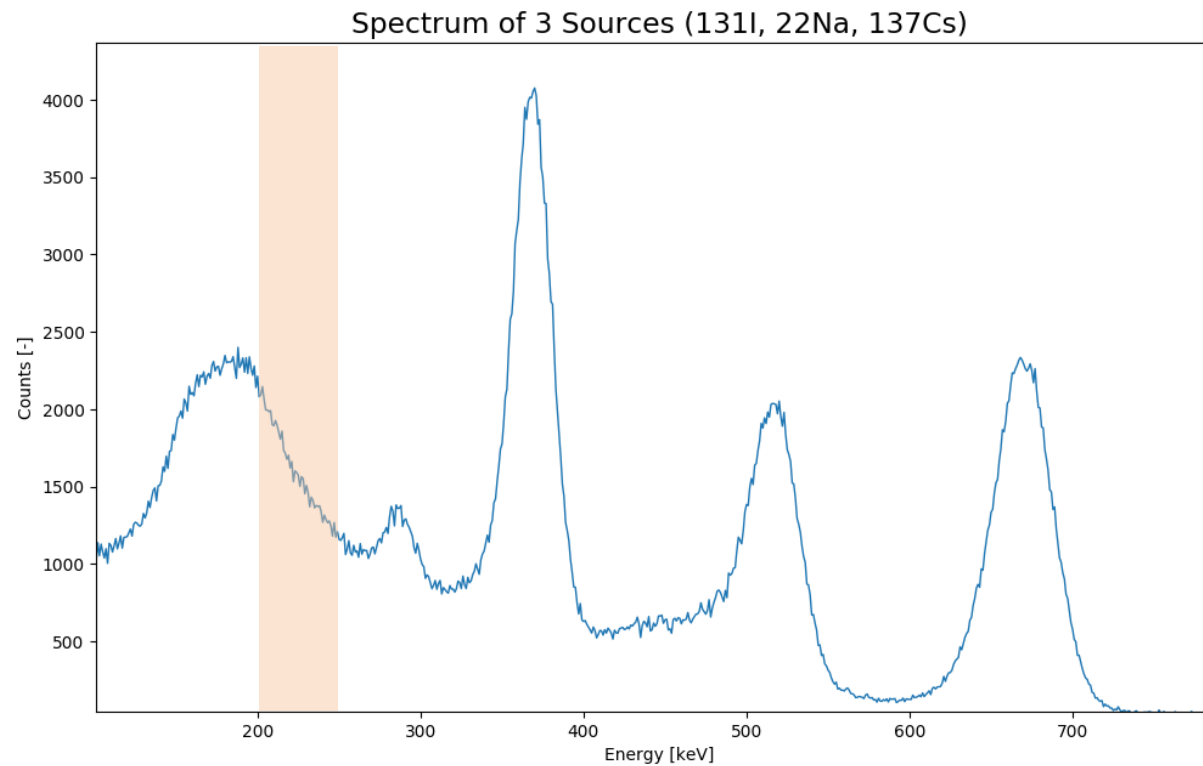
150 – 200 keV





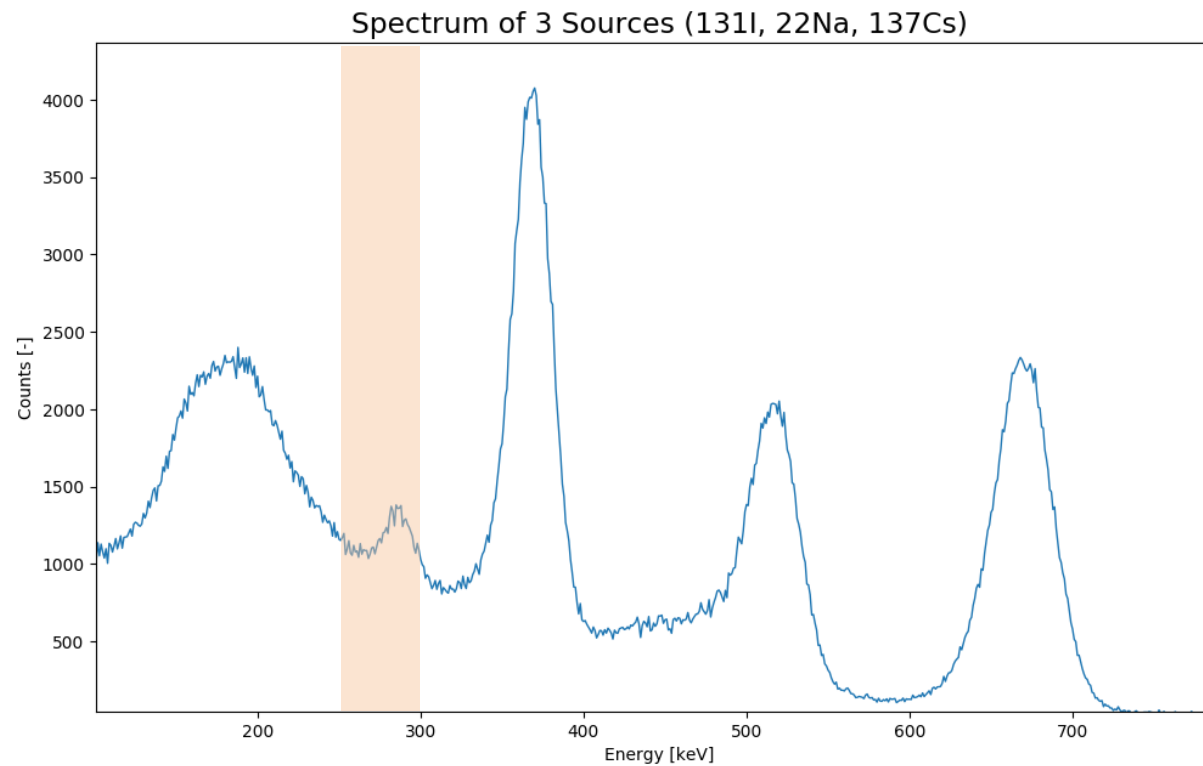
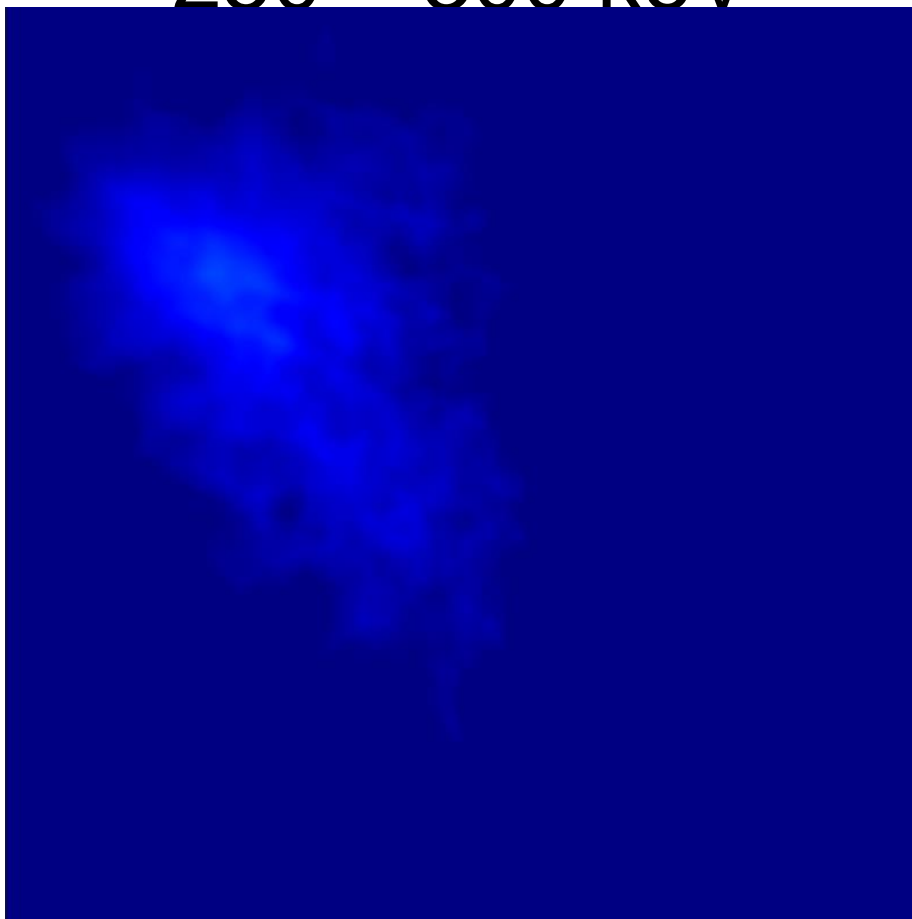
# Single Layer Compton Camera with MiniPIX TPX3 – Multiple Gamma Sources

200 – 250 keV



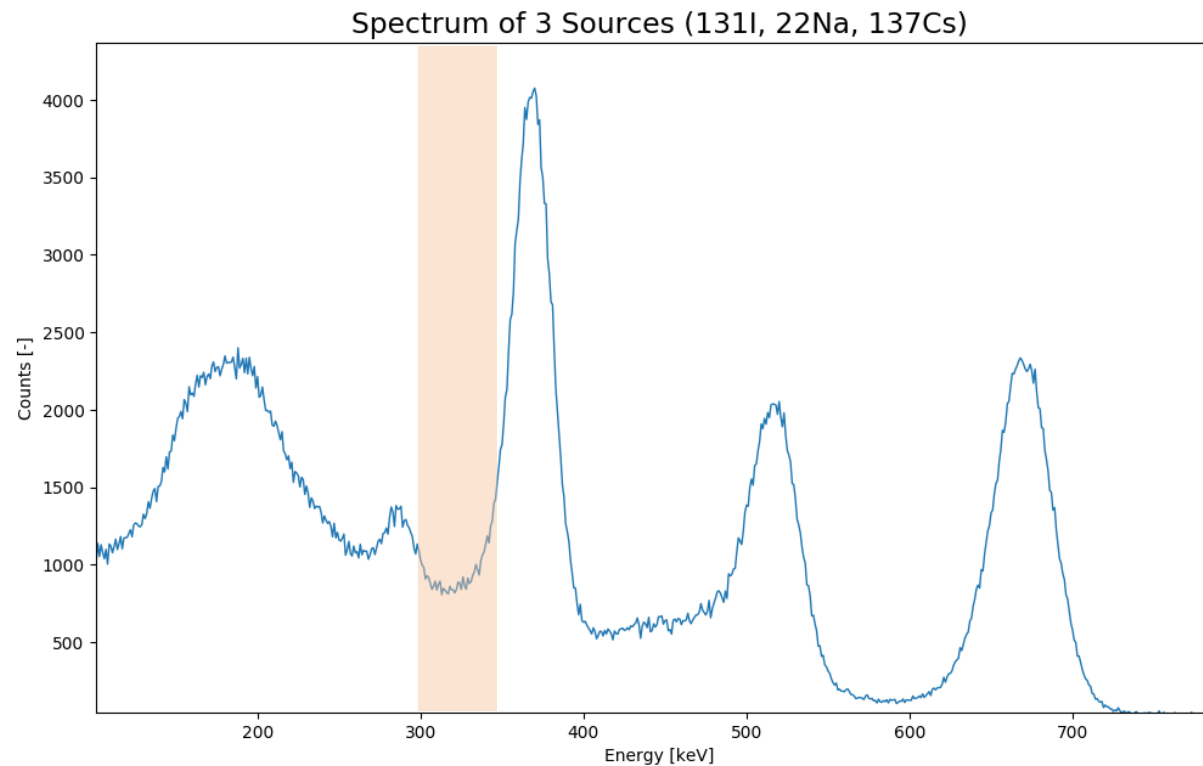
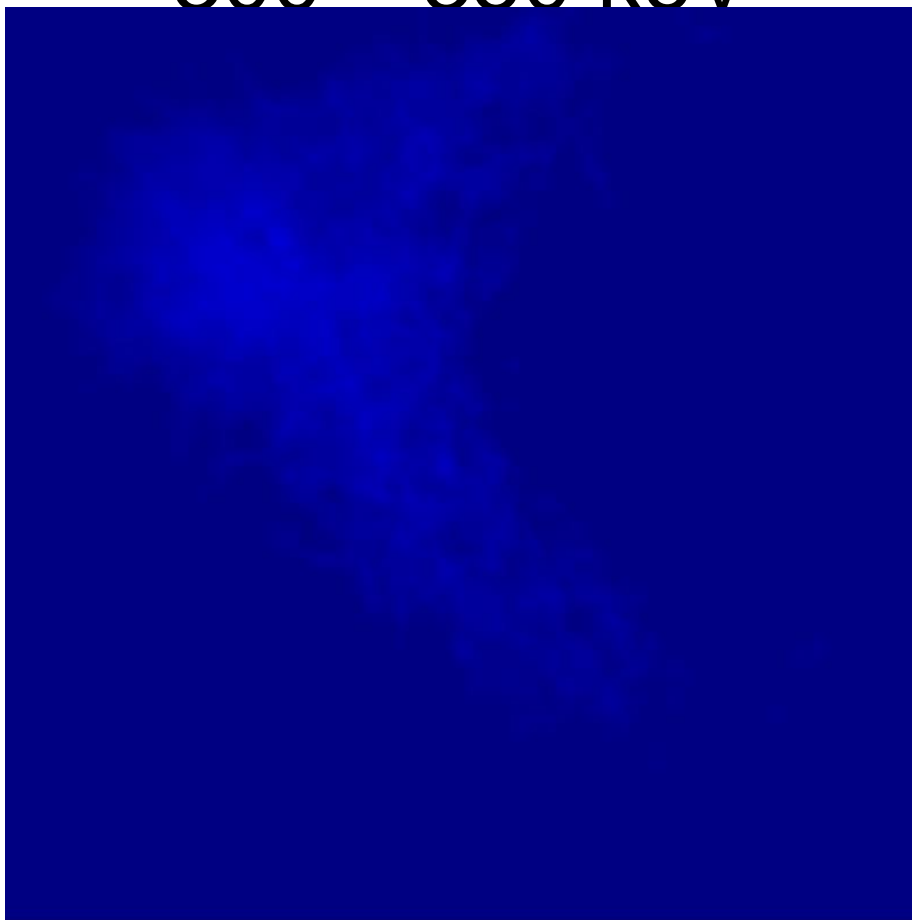
# Single Layer Compton Camera with MiniPIX TPX3 – Multiple Gamma Sources

250 – 300 keV



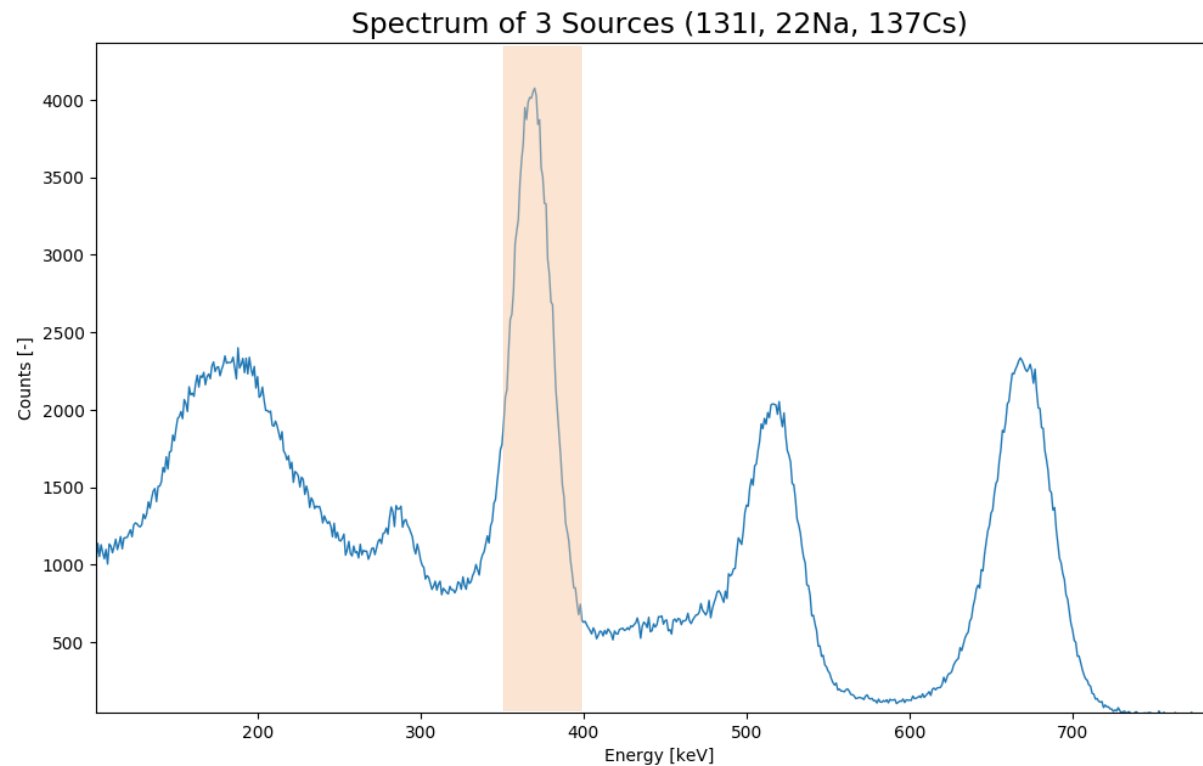
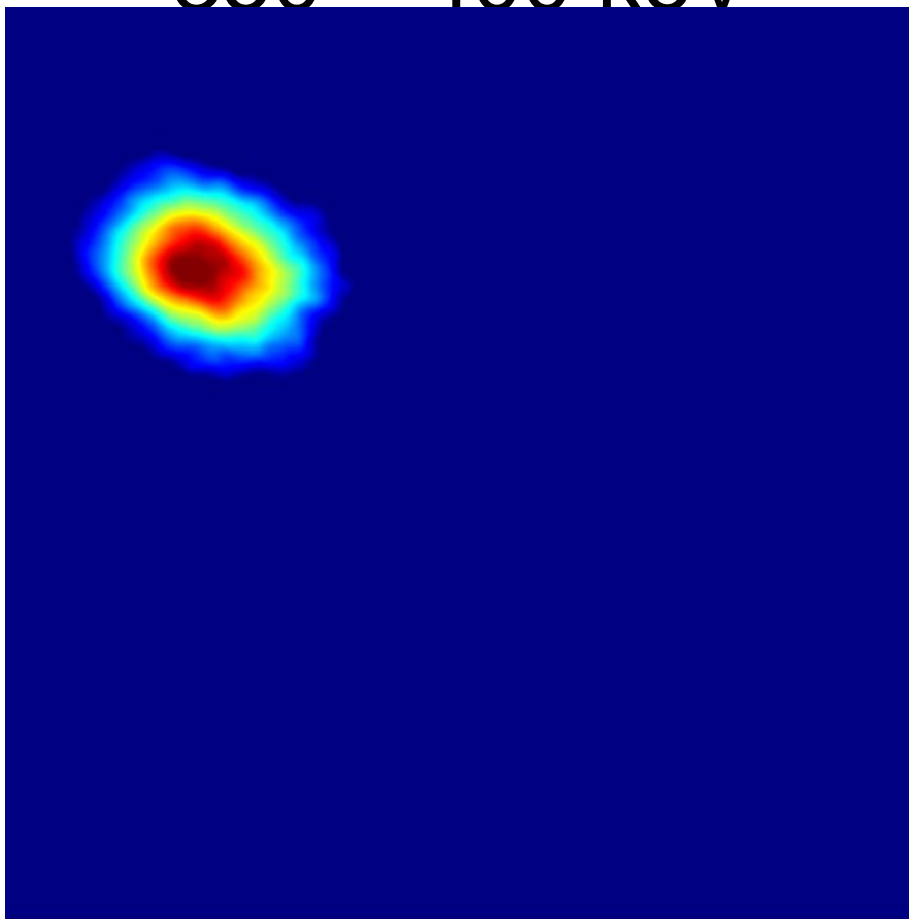
# Single Layer Compton Camera with MiniPIX TPX3 – Multiple Gamma Sources

300 – 350 keV



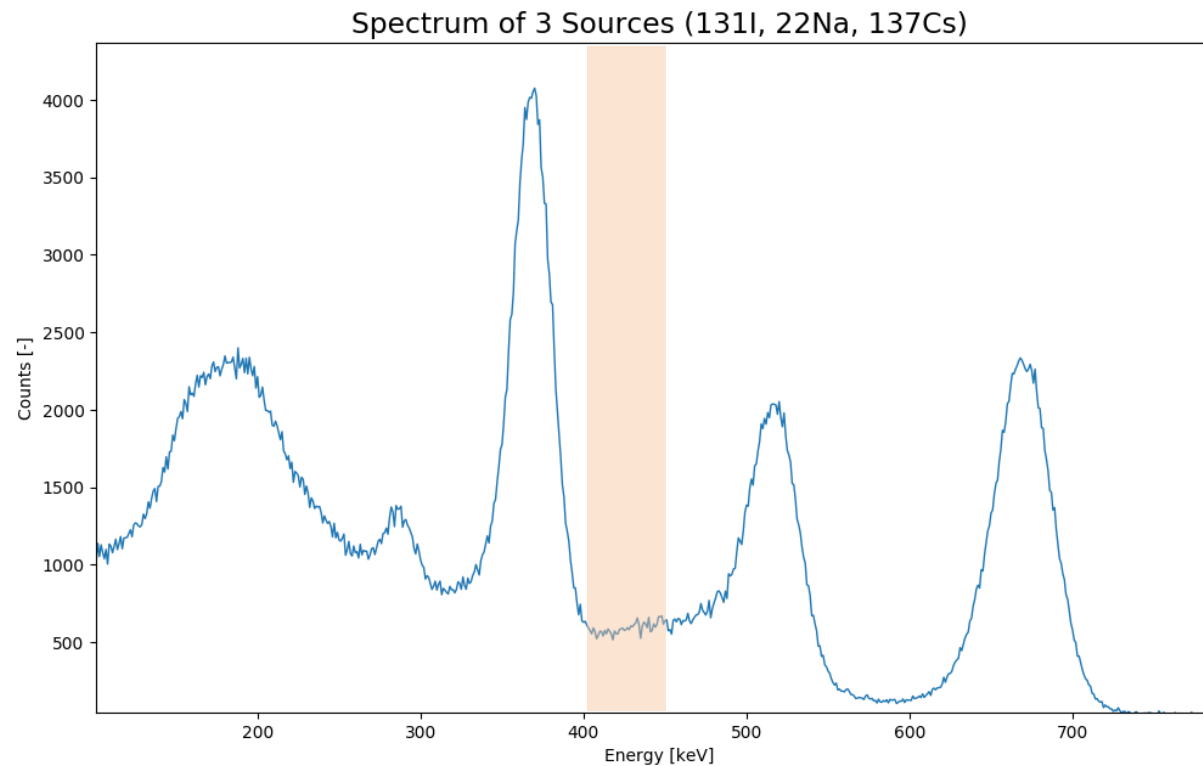
# Single Layer Compton Camera with MiniPIX TPX3 – Multiple Gamma Sources

350 – 400 keV



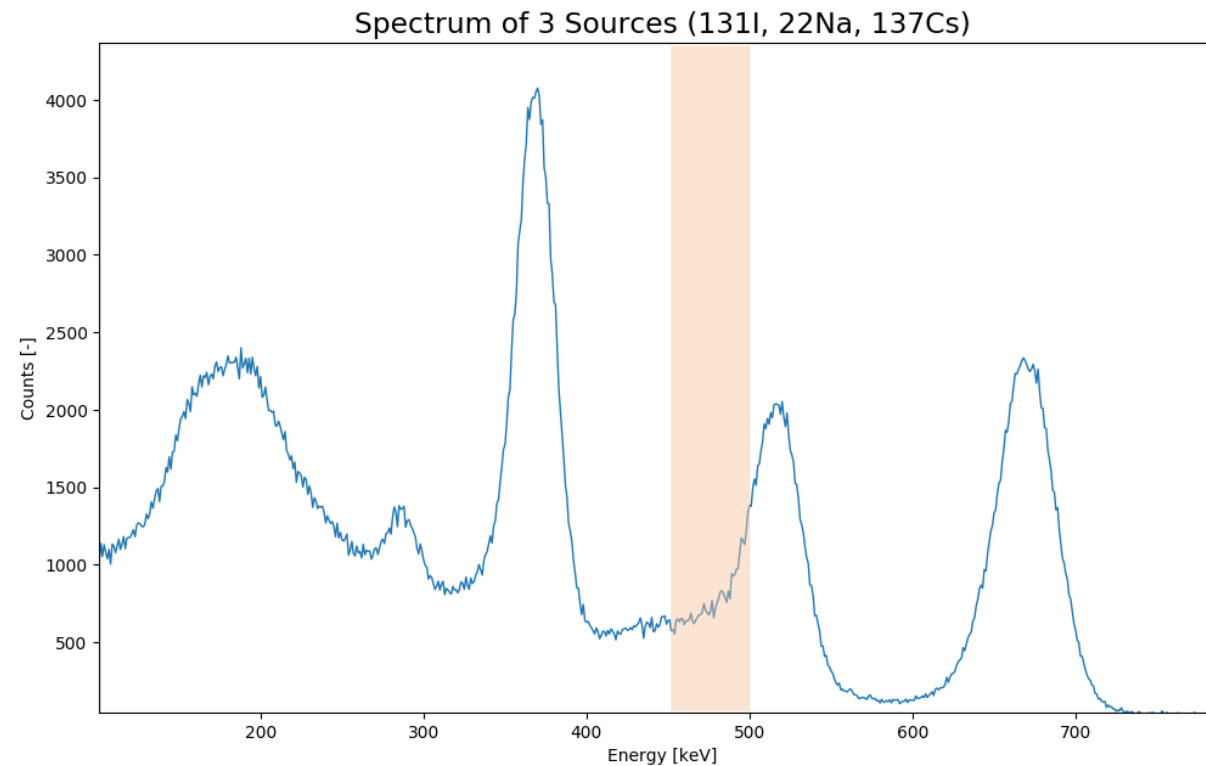
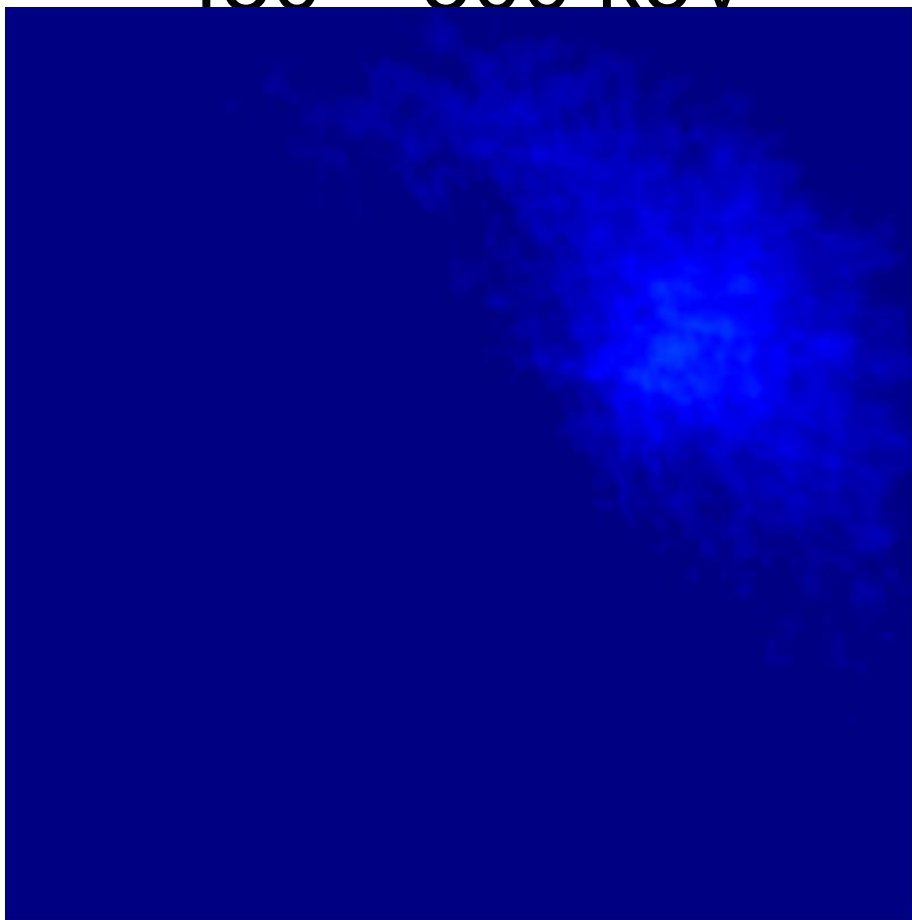
# Single Layer Compton Camera with MiniPIX TPX3 – Multiple Gamma Sources

400 – 450 keV



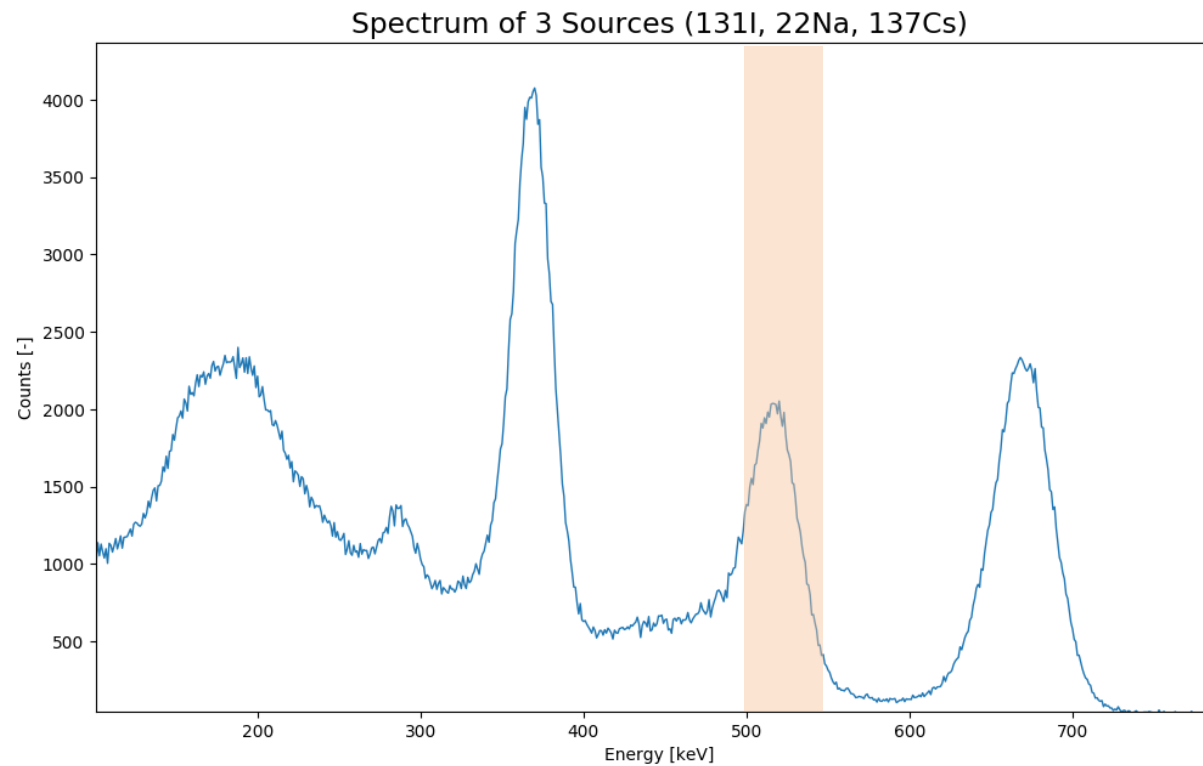
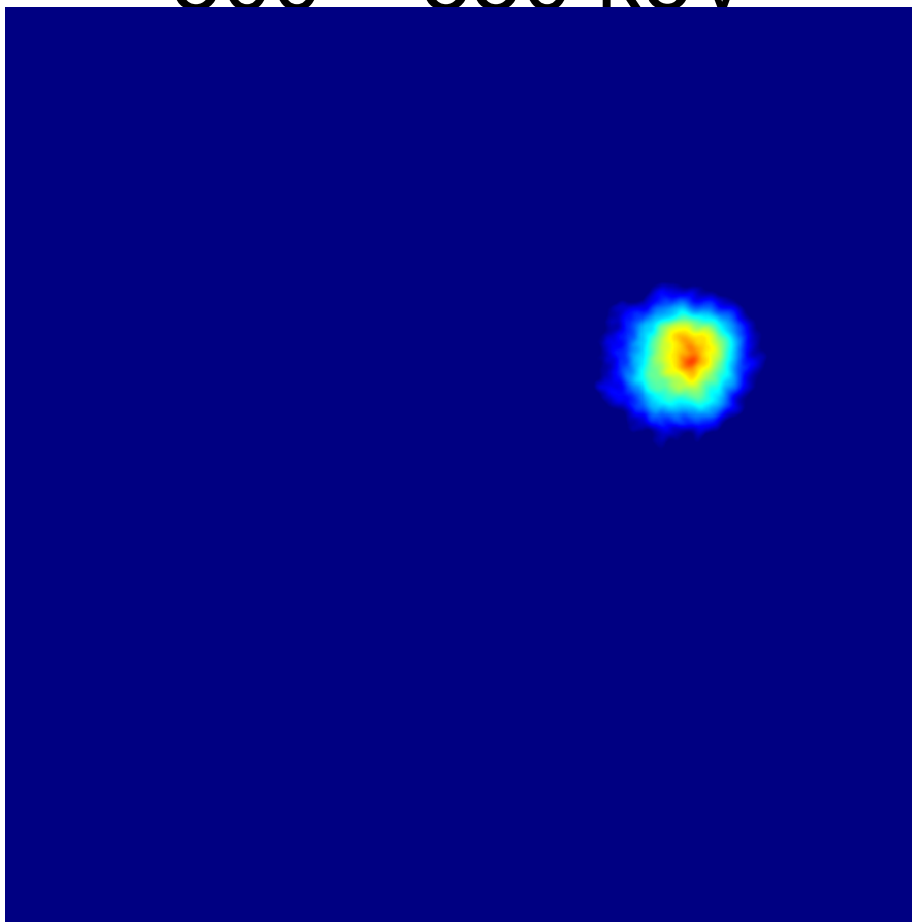
# Single Layer Compton Camera with MiniPIX TPX3 – Multiple Gamma Sources

450 – 500 keV



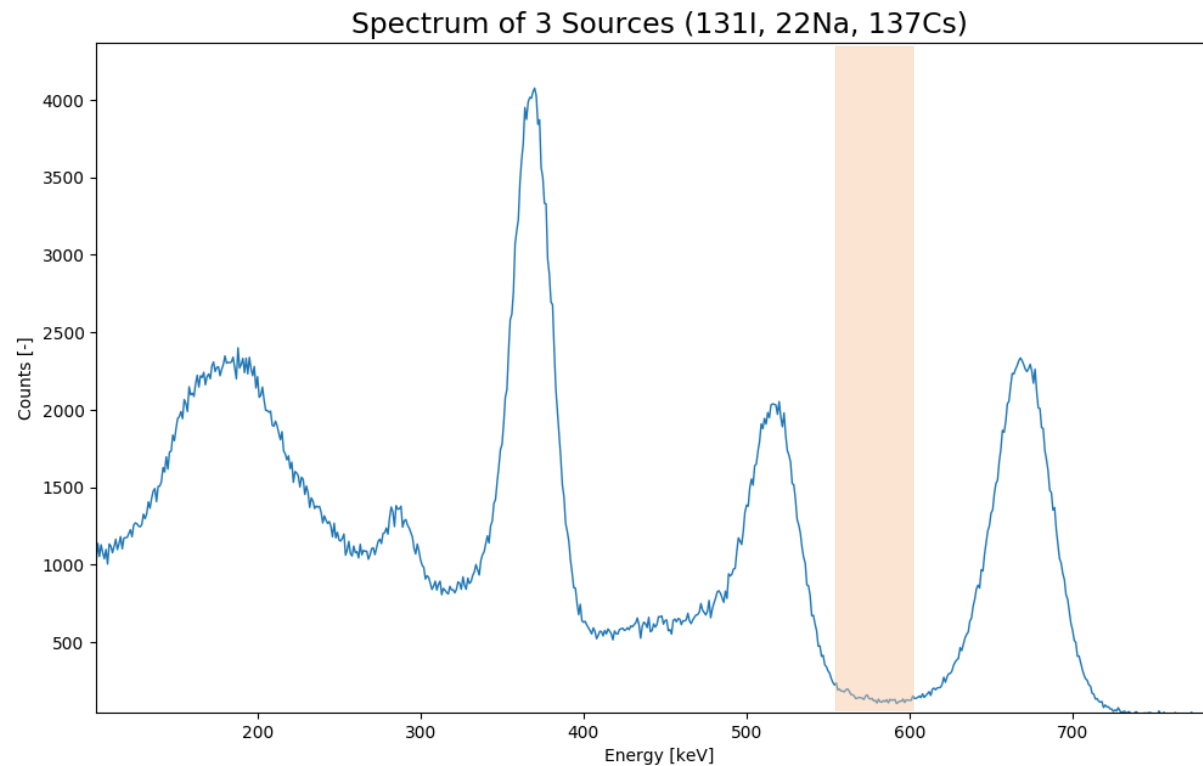
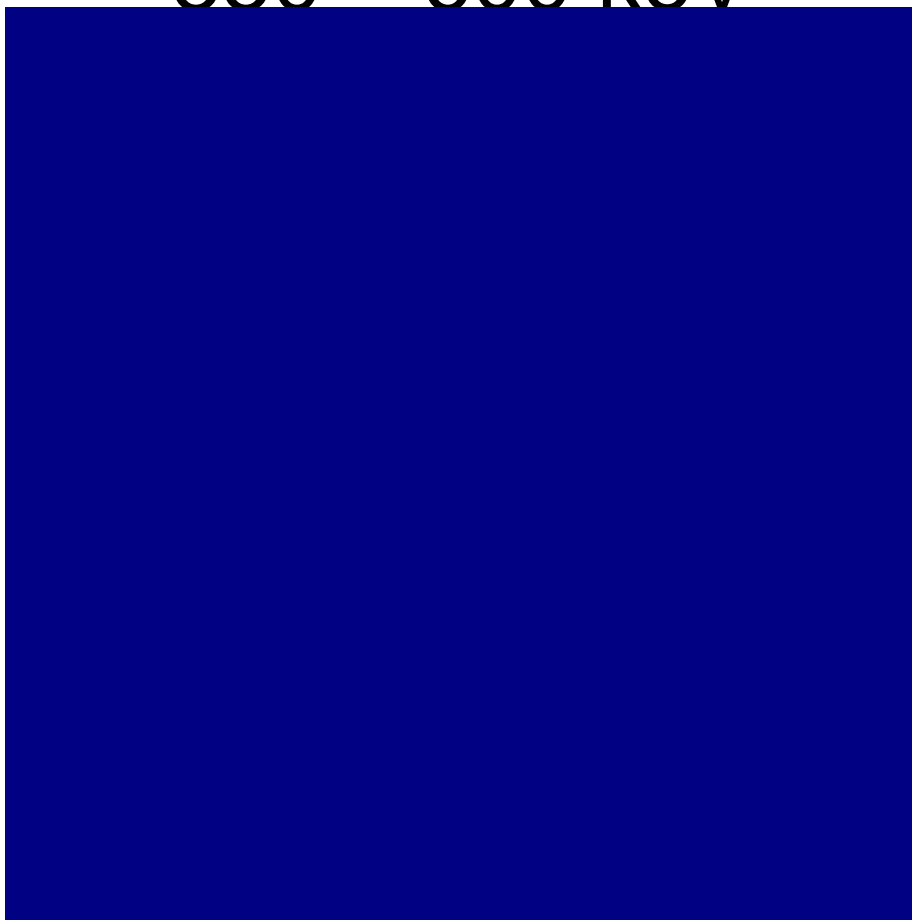
# Single Layer Compton Camera with MiniPIX TPX3 – Multiple Gamma Sources

500 – 550 keV



# Single Layer Compton Camera with MiniPIX TPX3 – Multiple Gamma Sources

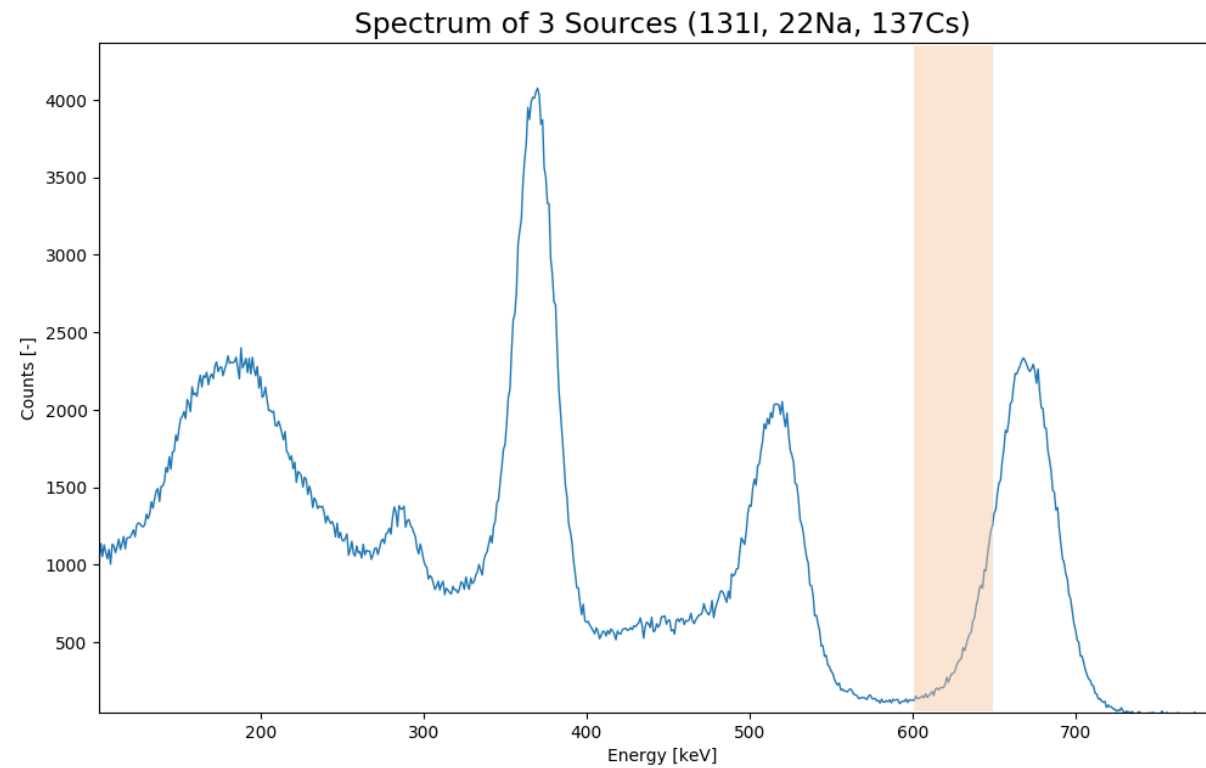
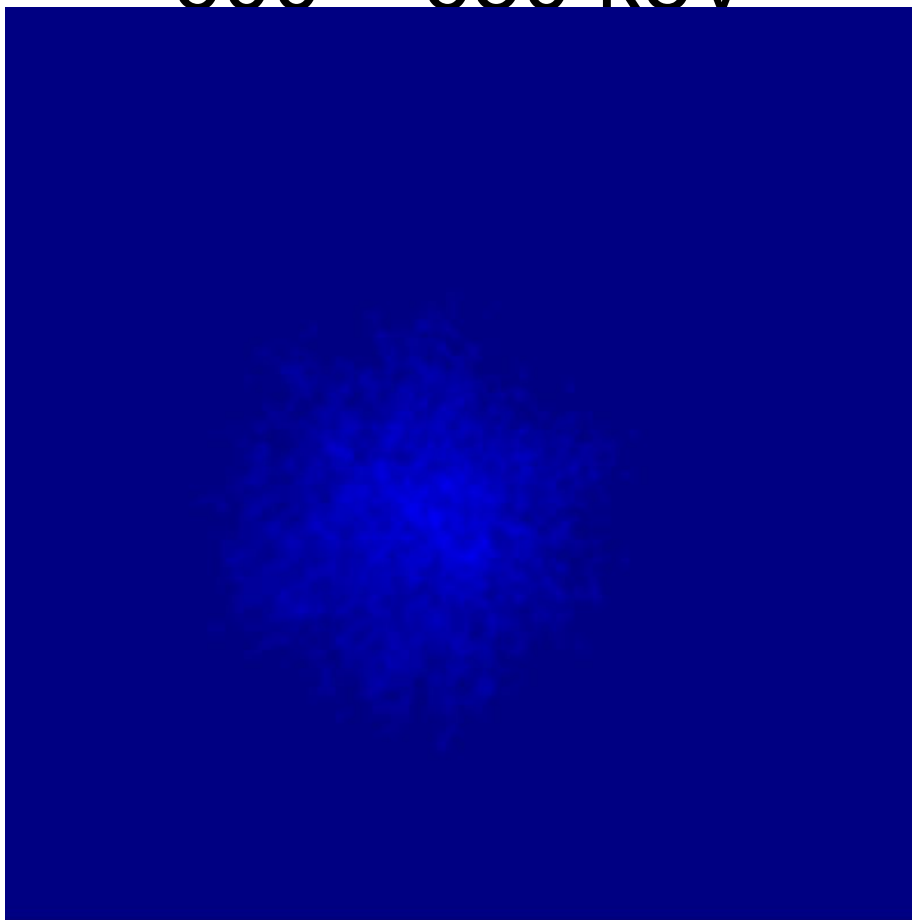
550 – 600 keV





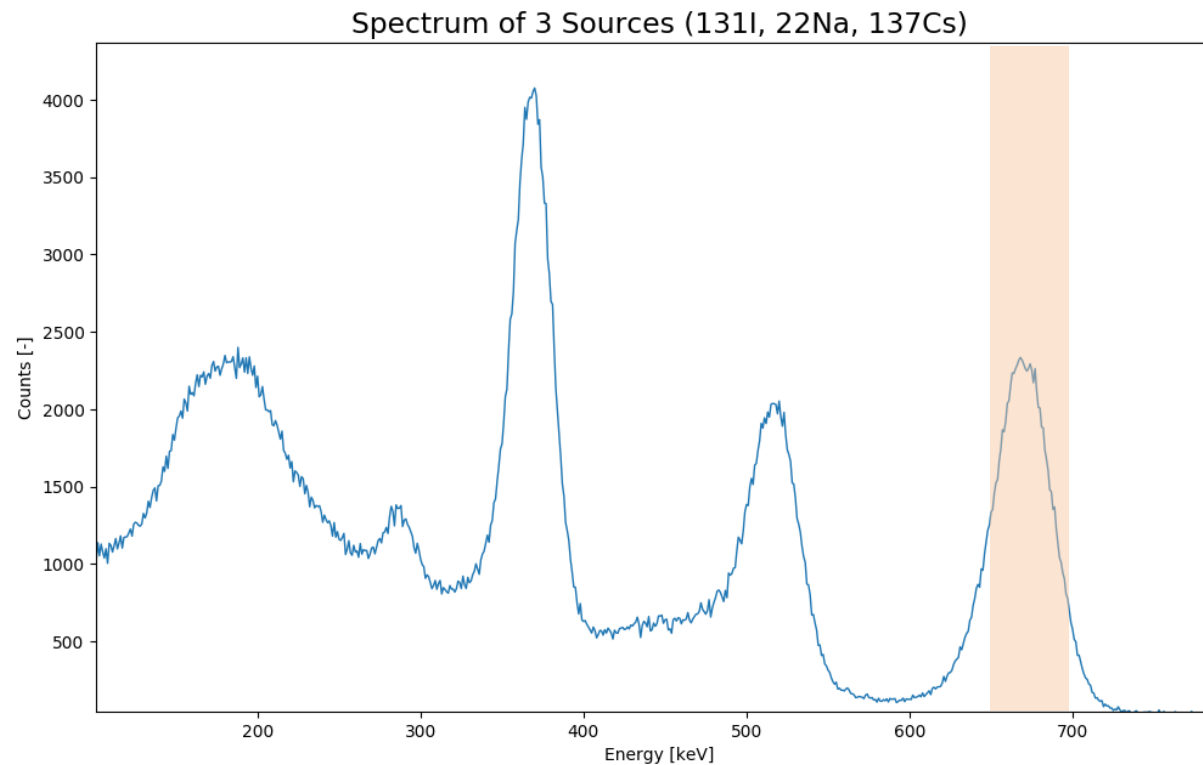
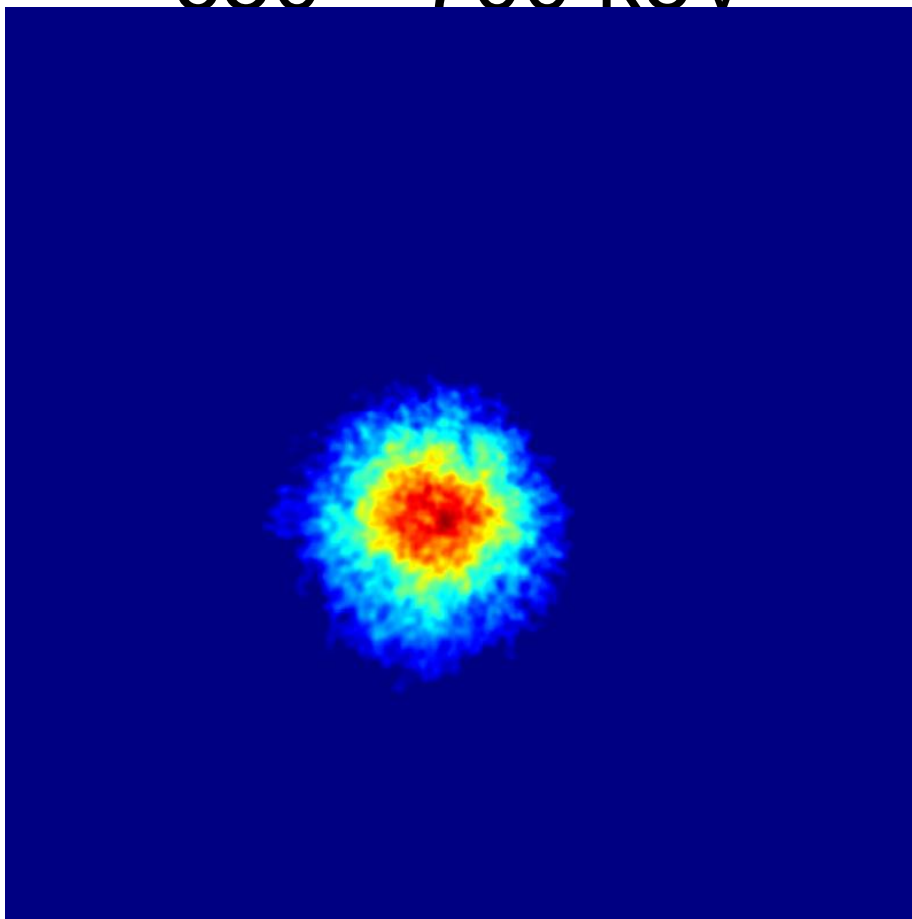
# Single Layer Compton Camera with MiniPIX TPX3 – Multiple Gamma Sources

600 – 650 keV



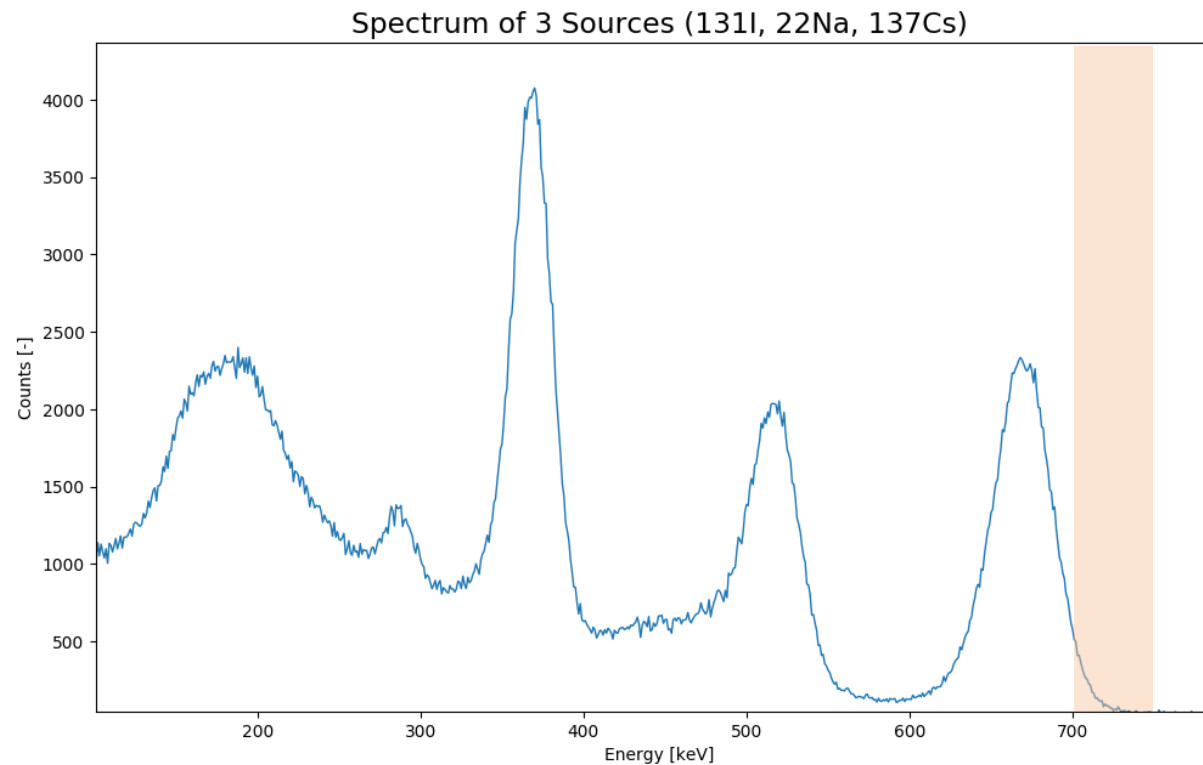
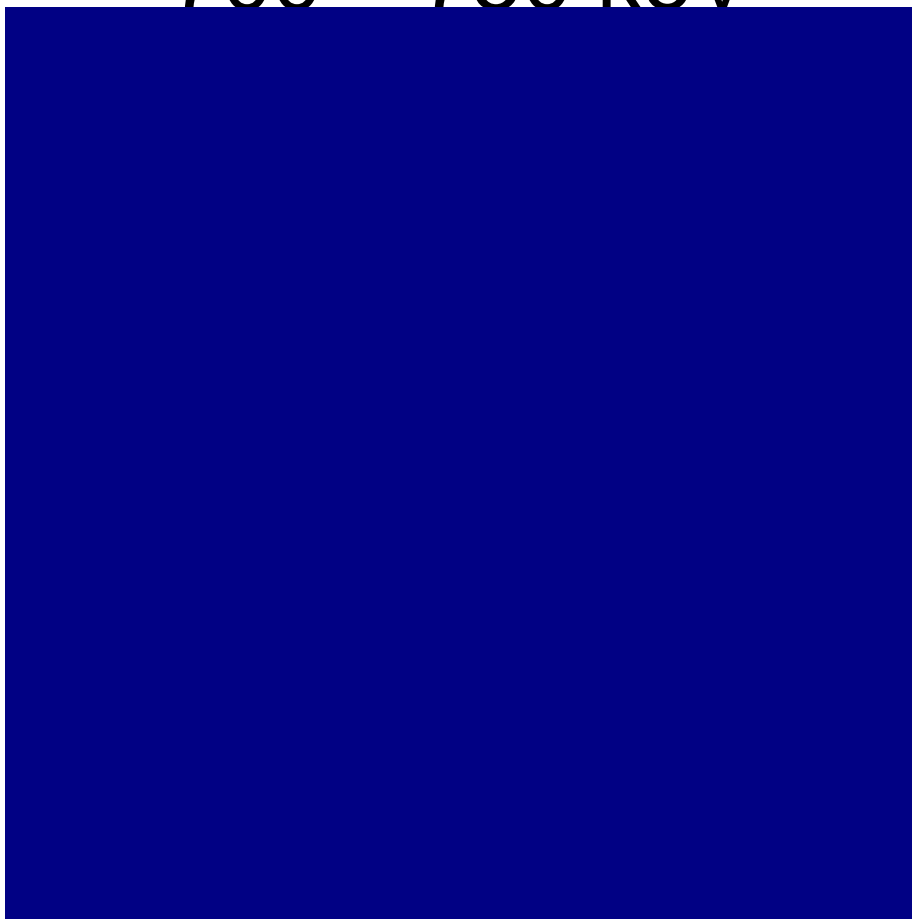
# Single Layer Compton Camera with MiniPIX TPX3 – Multiple Gamma Sources

650 – 700 keV



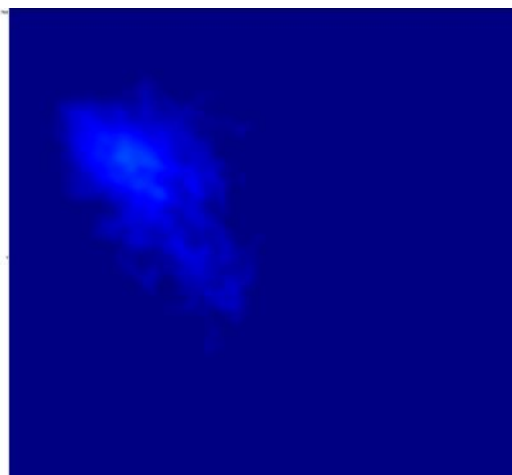
# Single Layer Compton Camera with MiniPIX TPX3 – Multiple Gamma Sources

700 – 750 keV

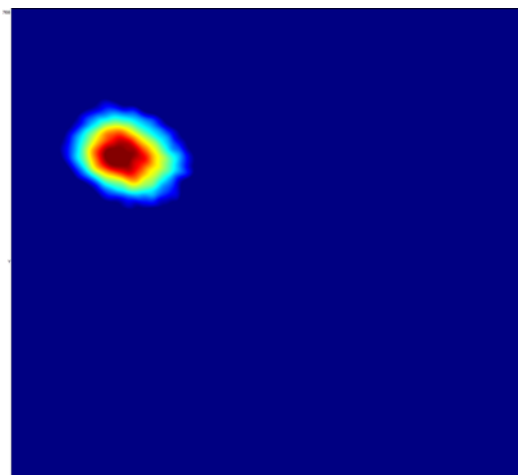


# Single Layer Compton Camera with MiniPIX TPX3 – Multiple Gamma Sources

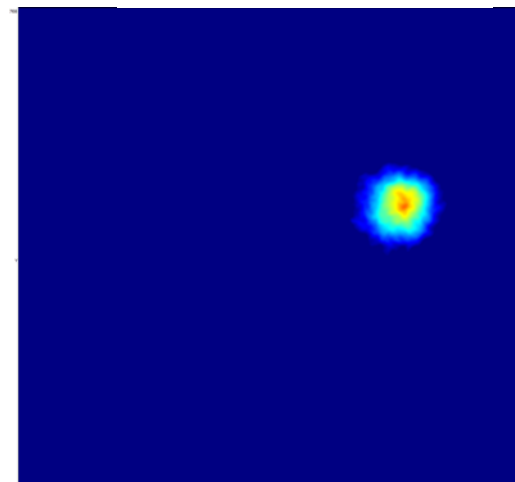
250 – 300 keV



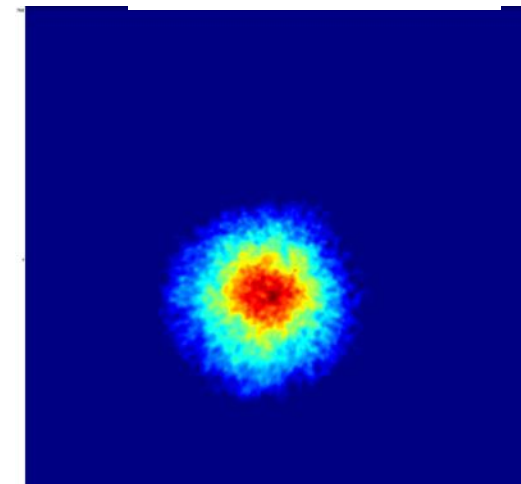
350 – 400 keV



500 – 550 keV



650 – 700 keV

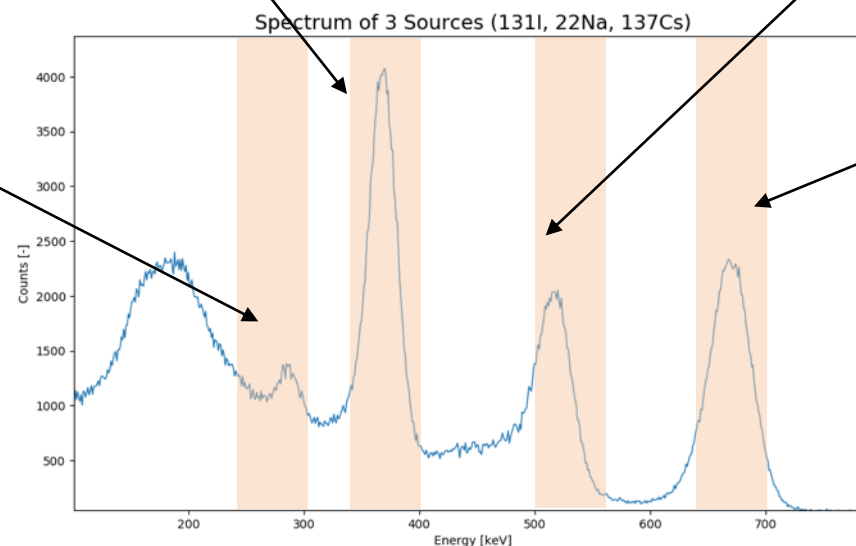


$^{131}\text{I}$  284 keV (7%)

$^{131}\text{I}$  364 keV

$^{22}\text{Na}$  511 keV

$^{137}\text{Cs}$  662 keV



# Gamma camera applications: Thyroid diagnostic

Thyroid cancer diagnostics and treatment monitoring:

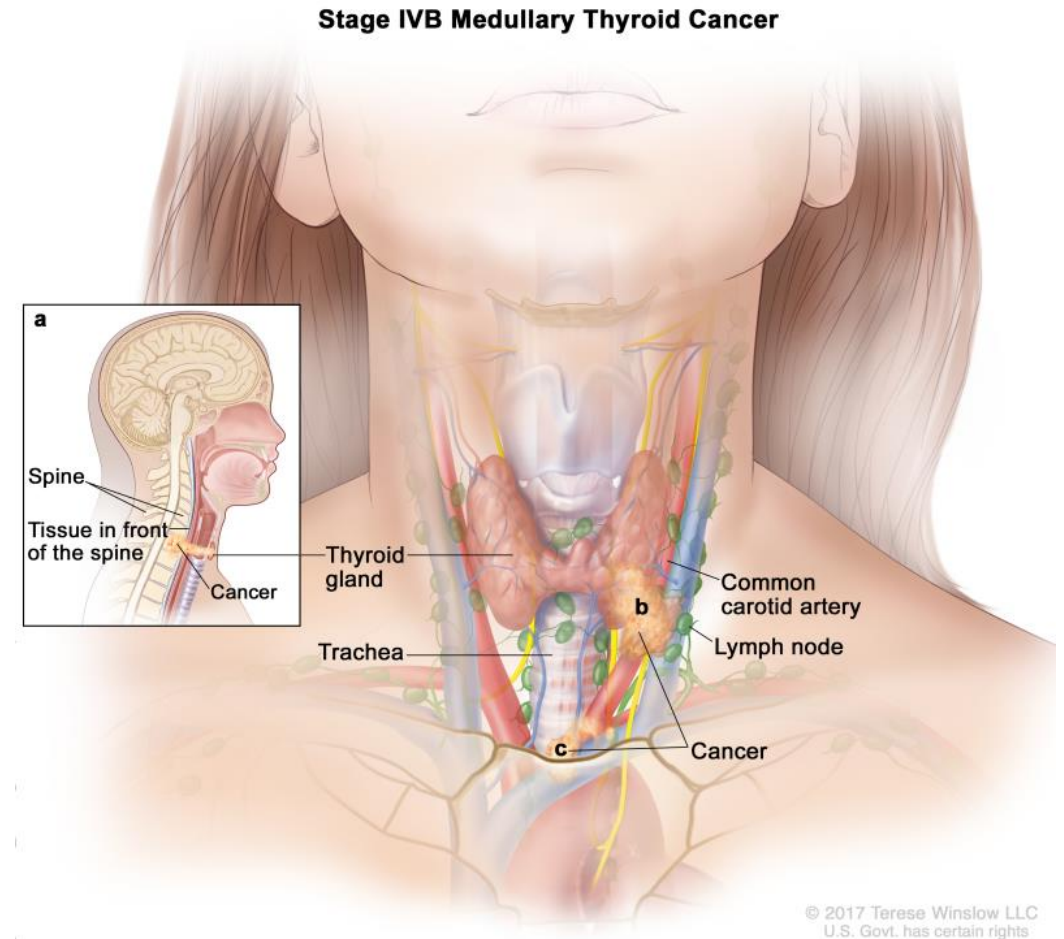
The second most frequent cancer for women (after breast cancer)

Current imaging methods offer resolution of about 12 mm in 2D

This technology allows

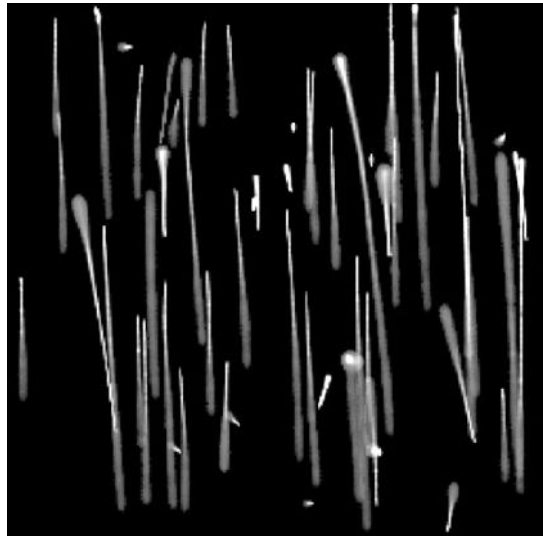
5 times better resolution and 3D (2.5 mm)

4 times lower dose



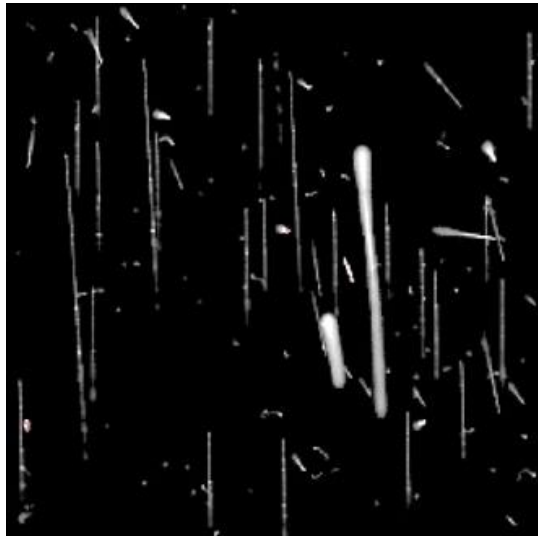
# In-line images of a hadron therapy beam

Protons 48 MeV



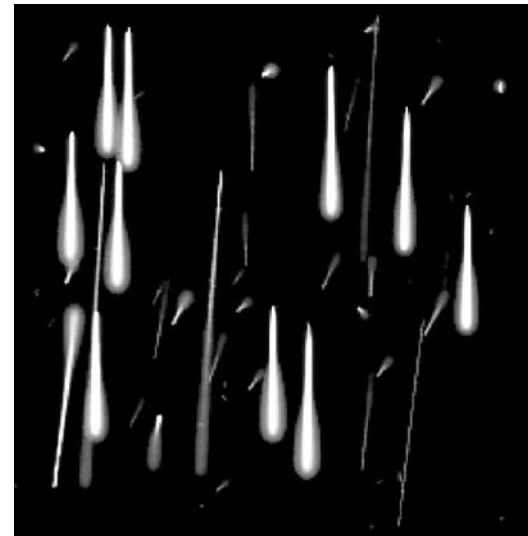
Only protons and their scattering, no secondaries.

Protons 221 MeV



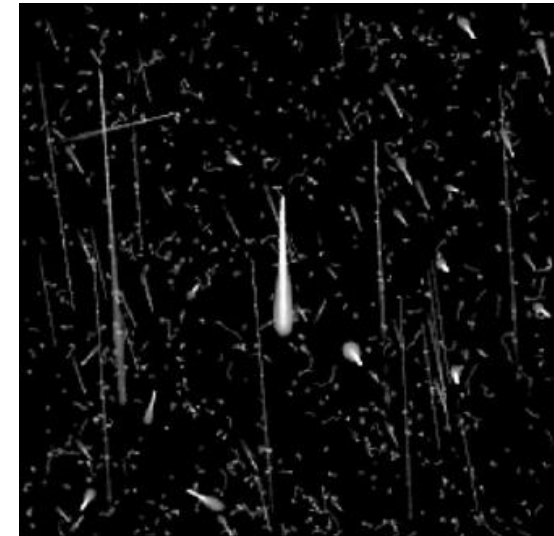
Many secondaries, (delta electrons fragments).

Carbons 89 MeV/u



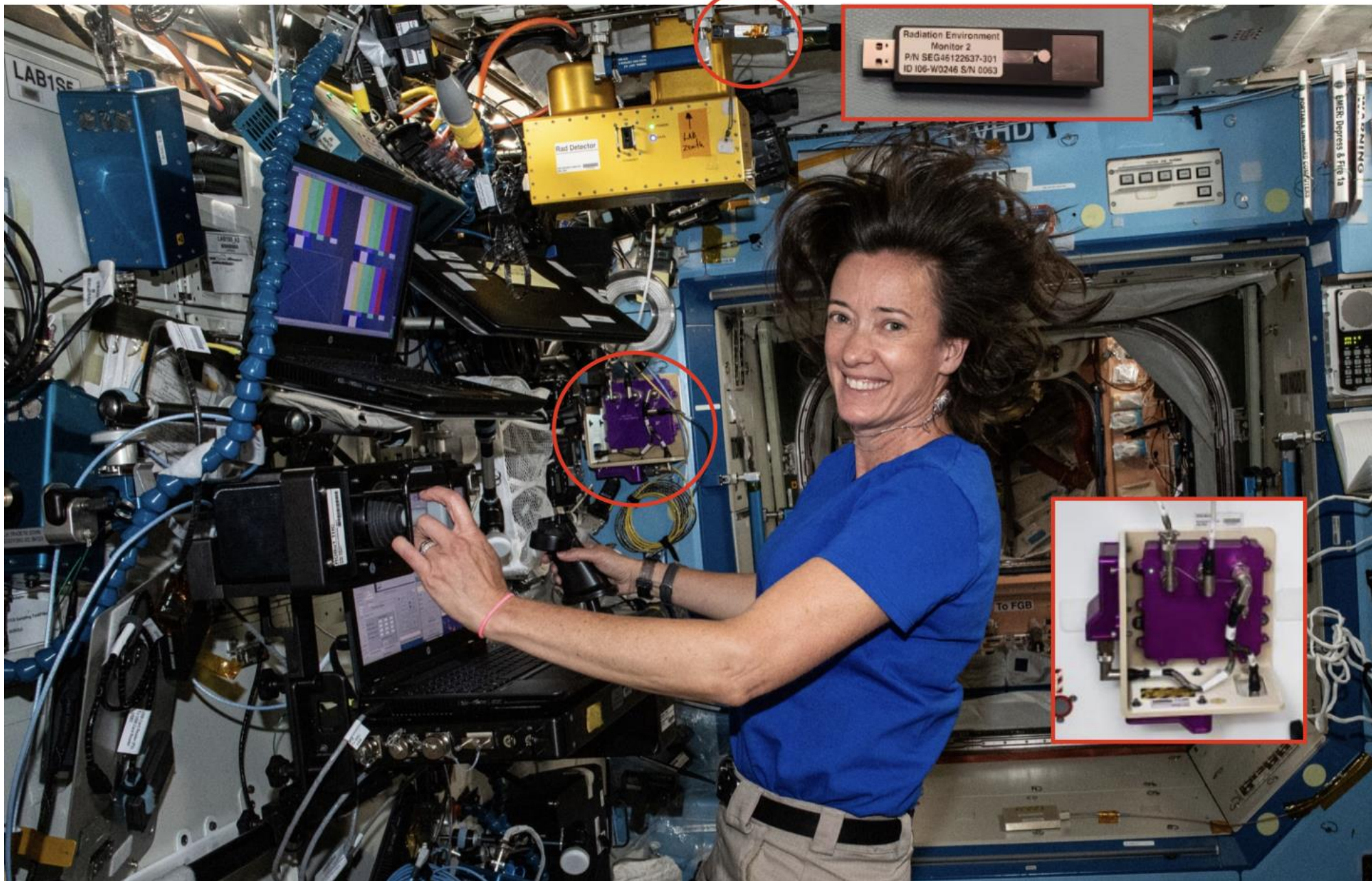
Carbons and protons and their scattering, no secondaries.

Carbons 430 MeV/u



Carbons and many secondaries.

Timepix chip combined with Si detector



# TimePIX 3 photon fluence measurement in hospital theatres



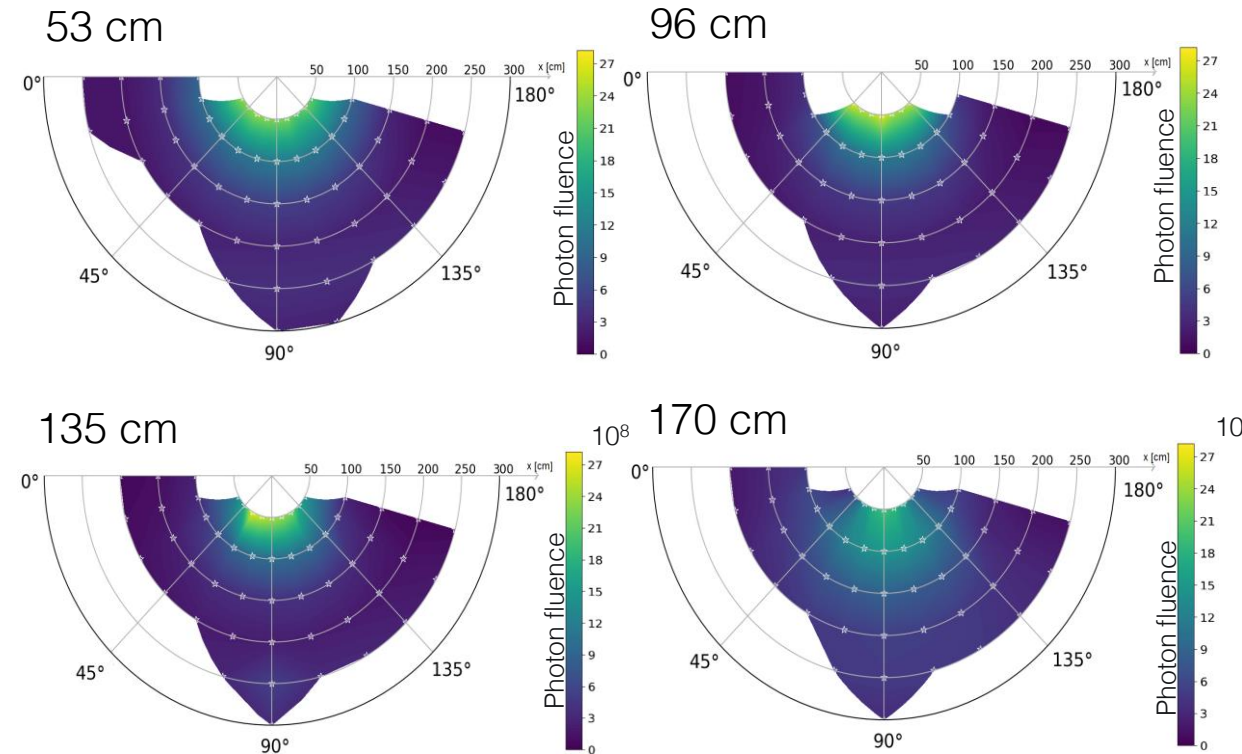
Reference person: 1.76 m

Eye lens - 170 cm

Chest - 135 cm

Belt - 96 cm

Knee - 53 cm



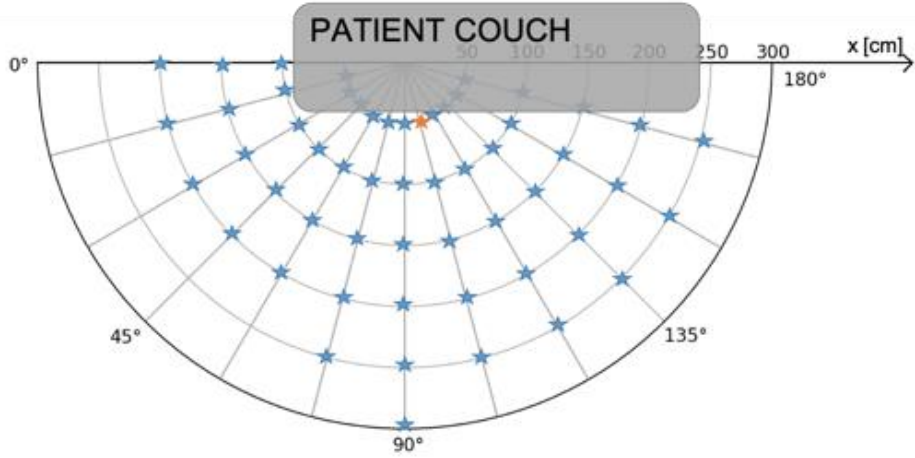
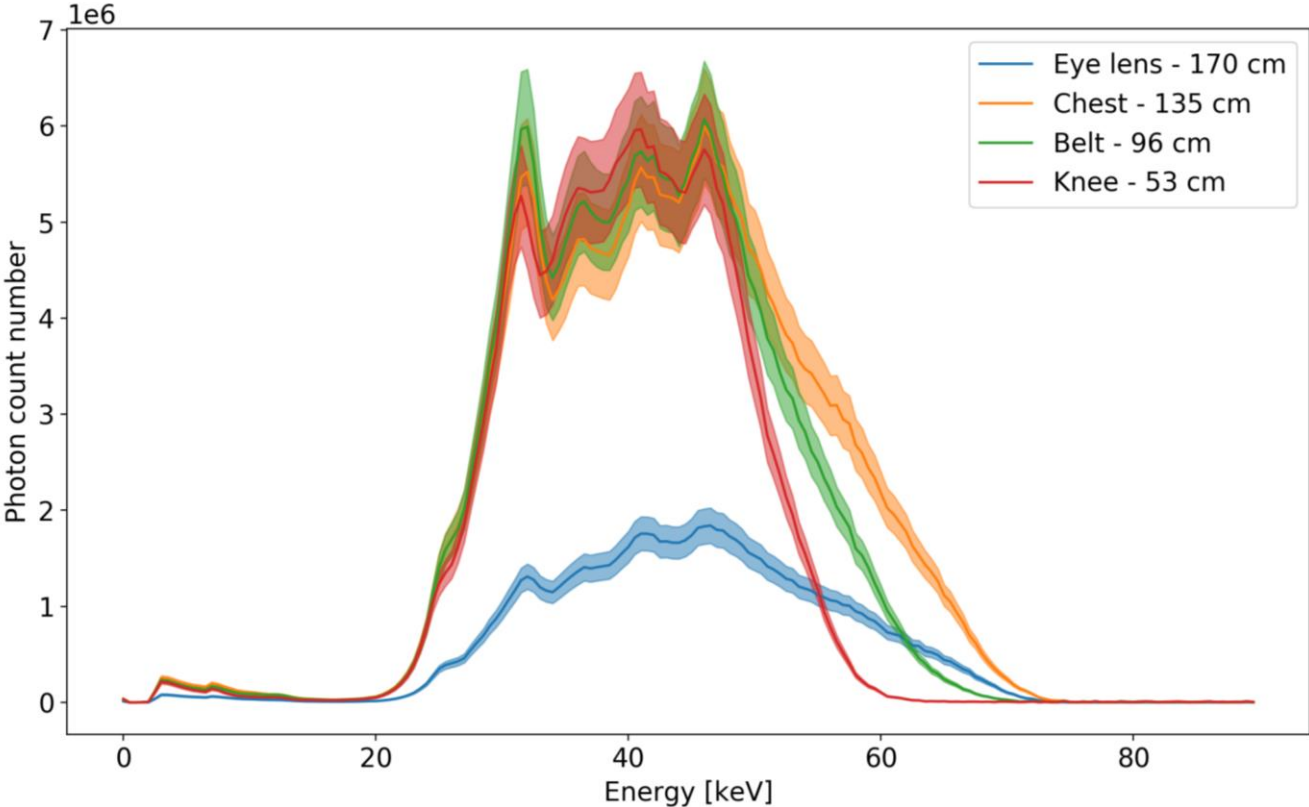
Colour maps of the photon fluence measured with a Timepix III in an hospital theatre at four horizontal eights.

Courtesy of M. Nowak



# TimePIX 3 photon fluence measurement in hospital theatres

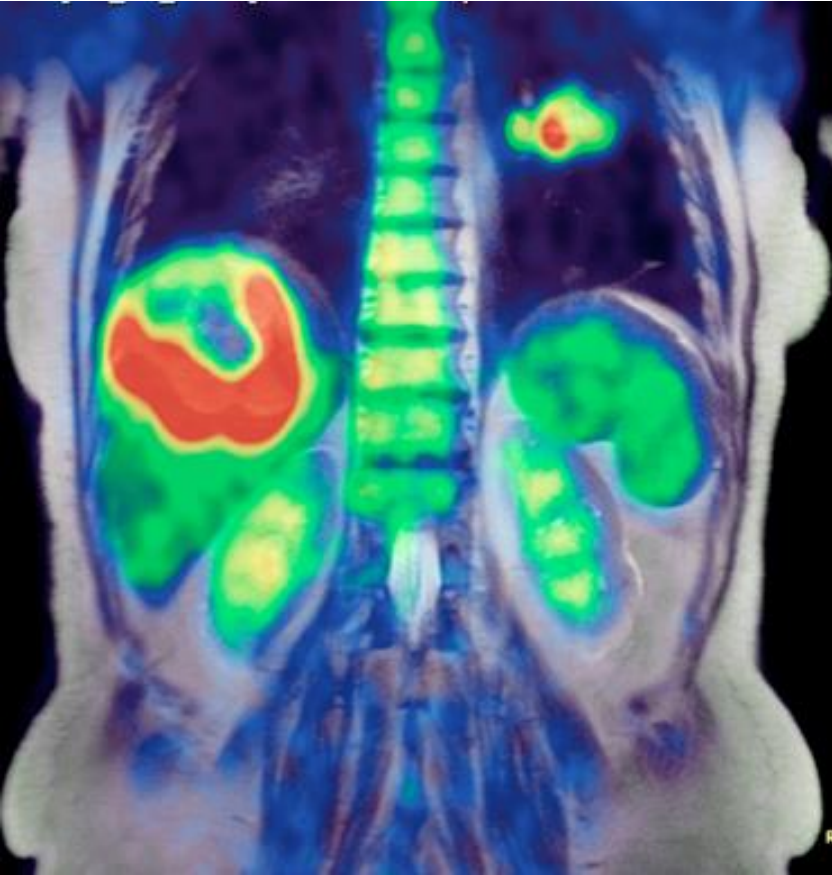
Energy spectra for each height for a given person



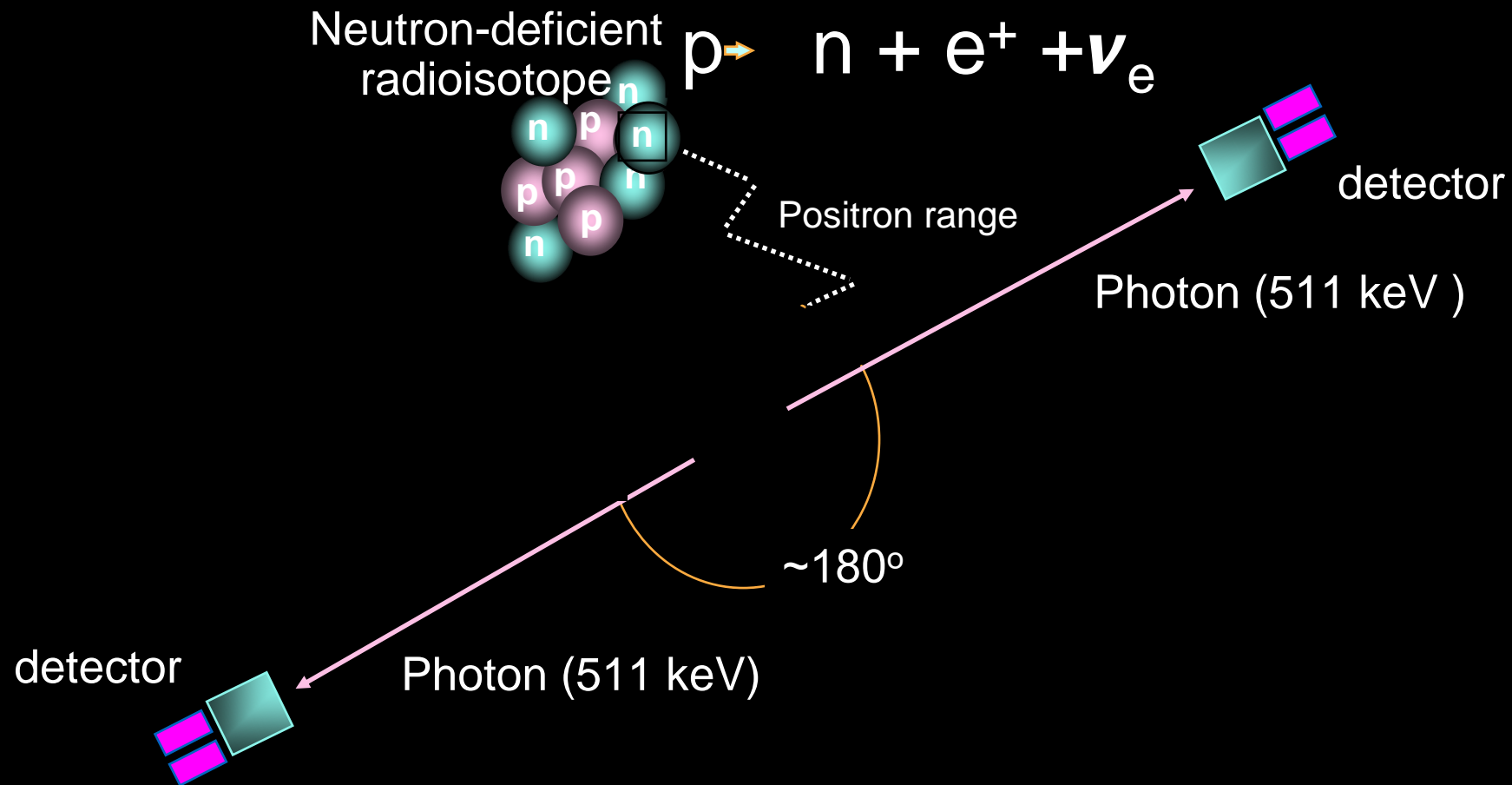
Courtesy of M. Nowak

➡ Shift in energy from head to toes = non homogenous exposure

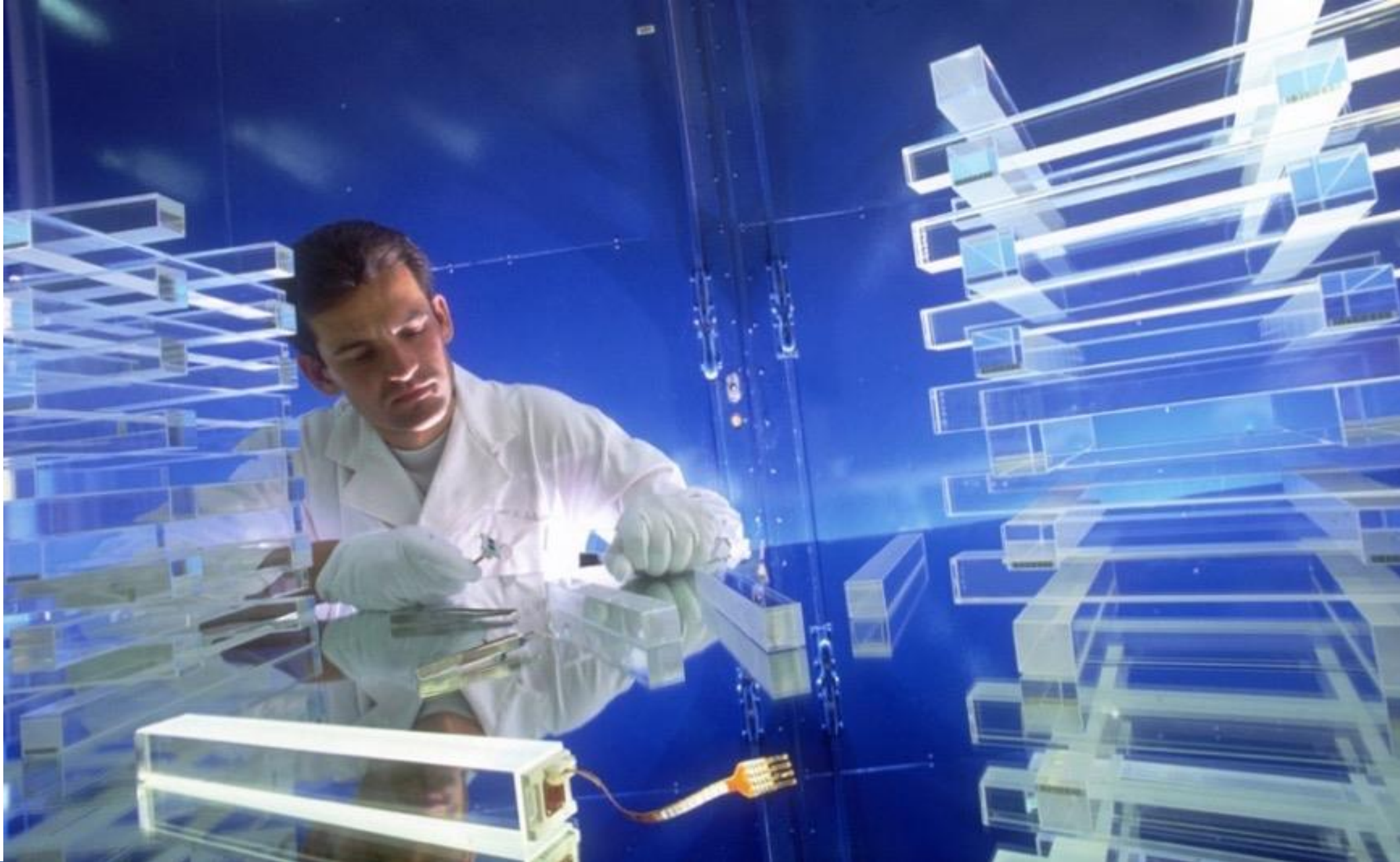
# PET



# Positron Emission Tomography



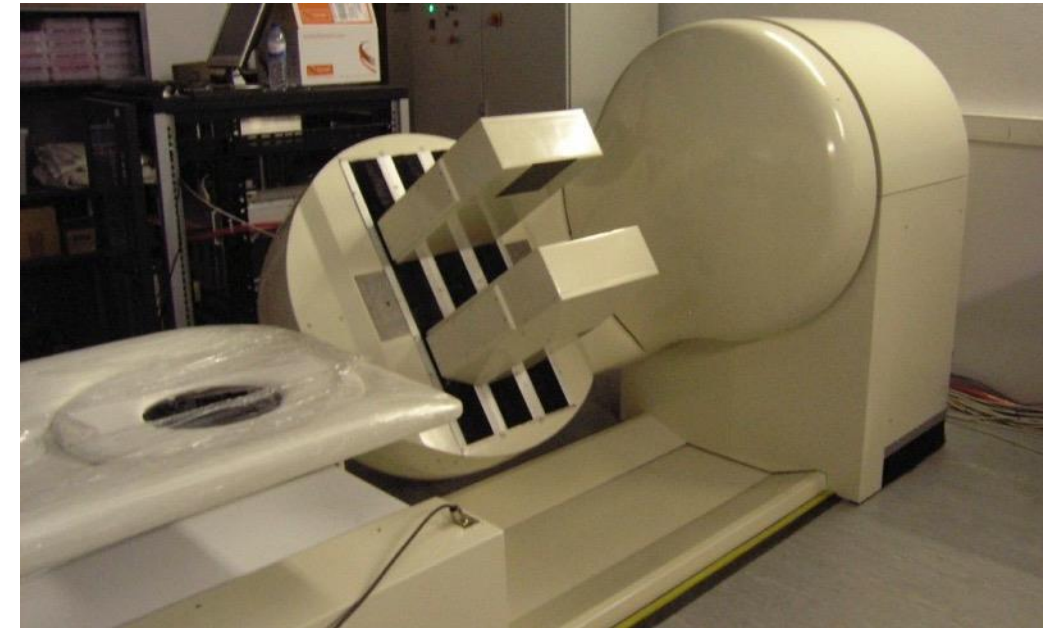
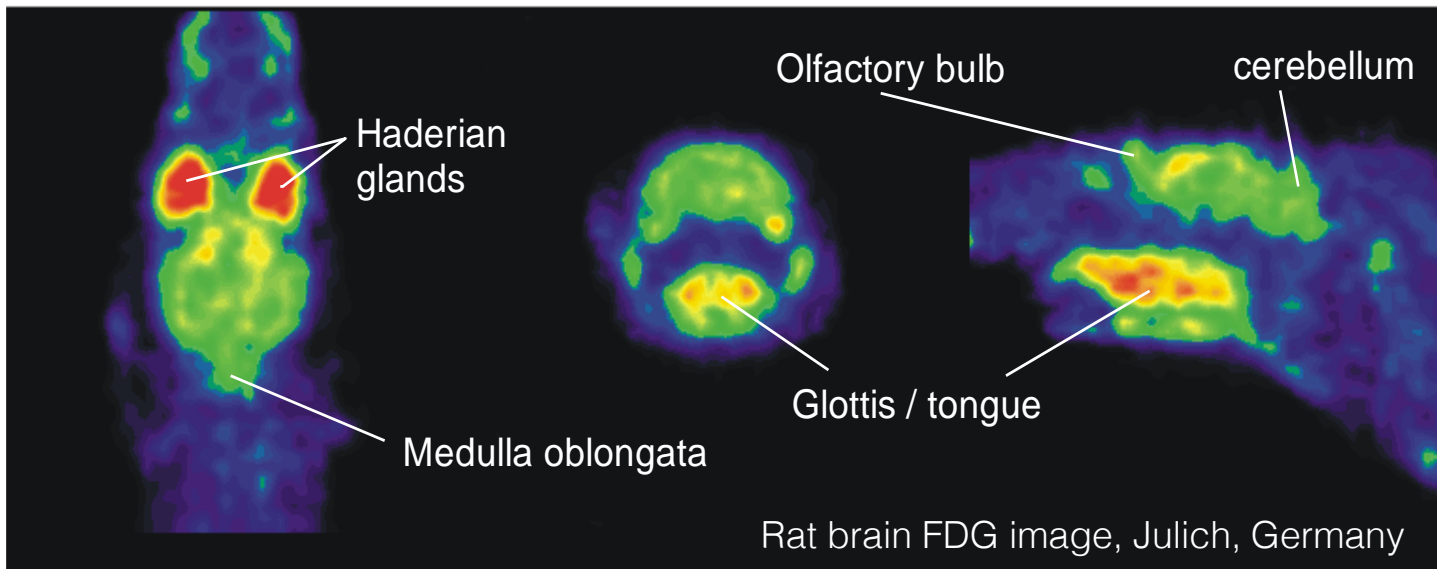






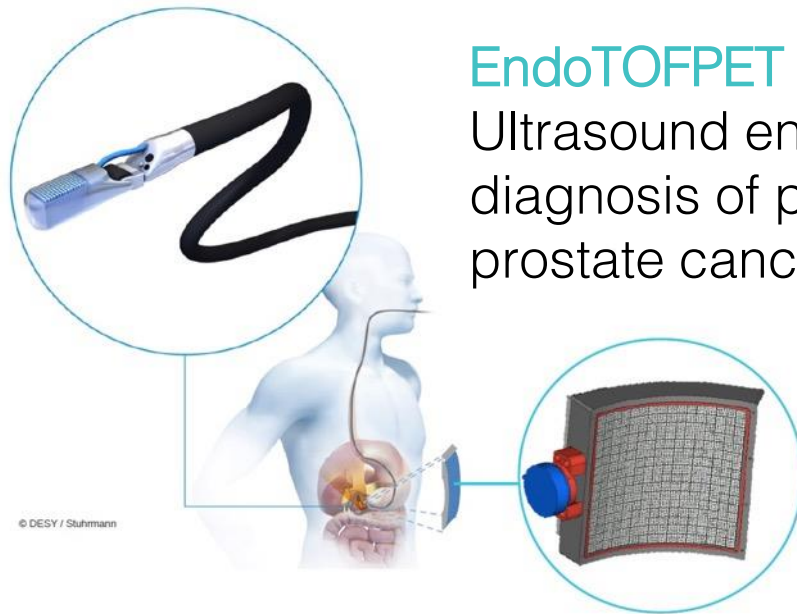
## ClearPET

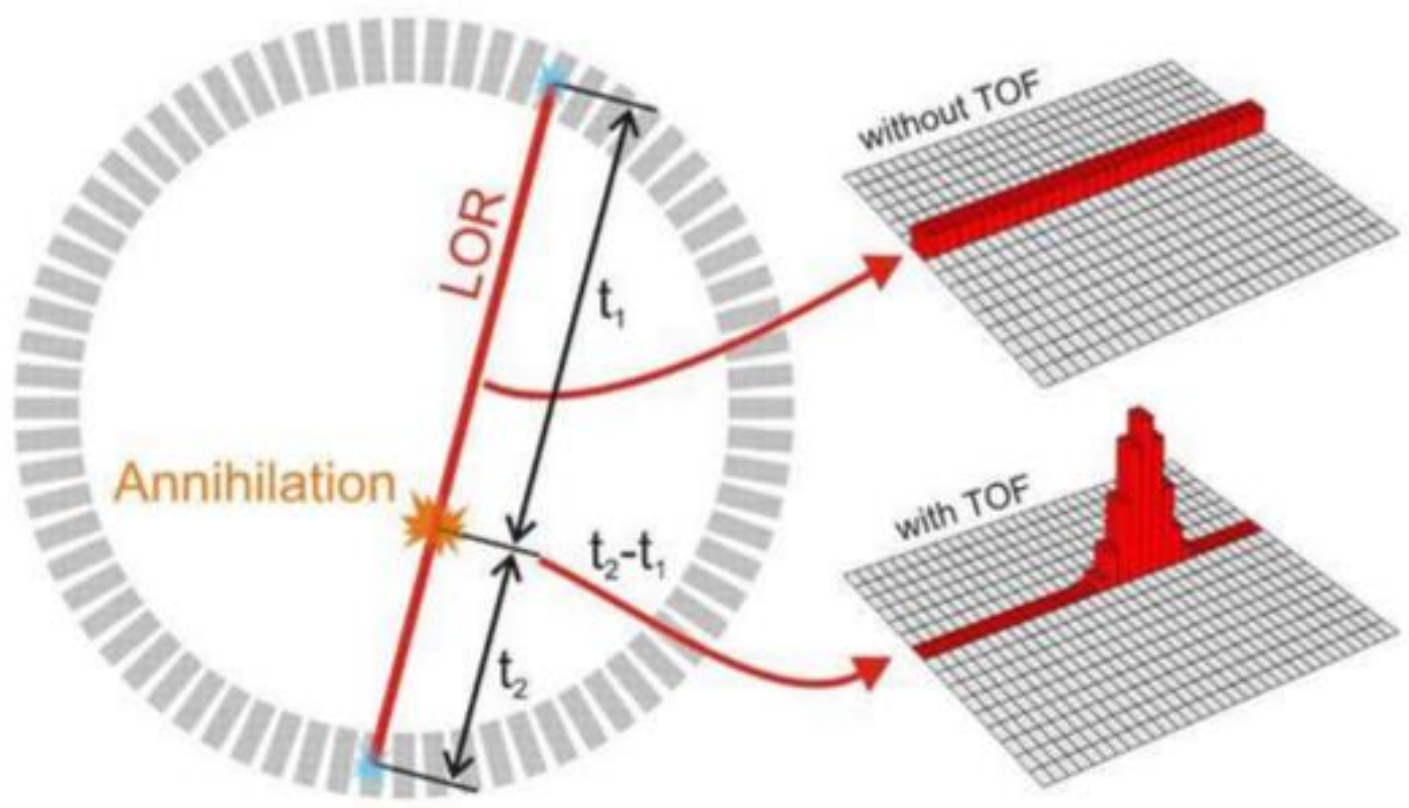
PET for small animals



## ClearPEM

Dedicated scanner for breast imaging







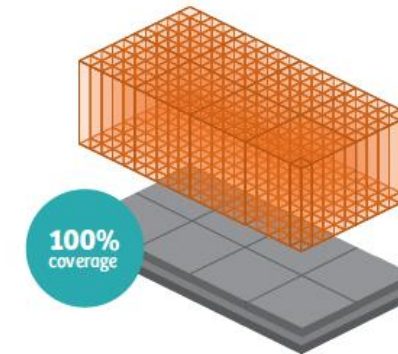
# Current status commercial TOF-PET



## TOF PET SIEMENS: BIOGRAPH VISION



3.2mm section crystals  
CTR 215ps

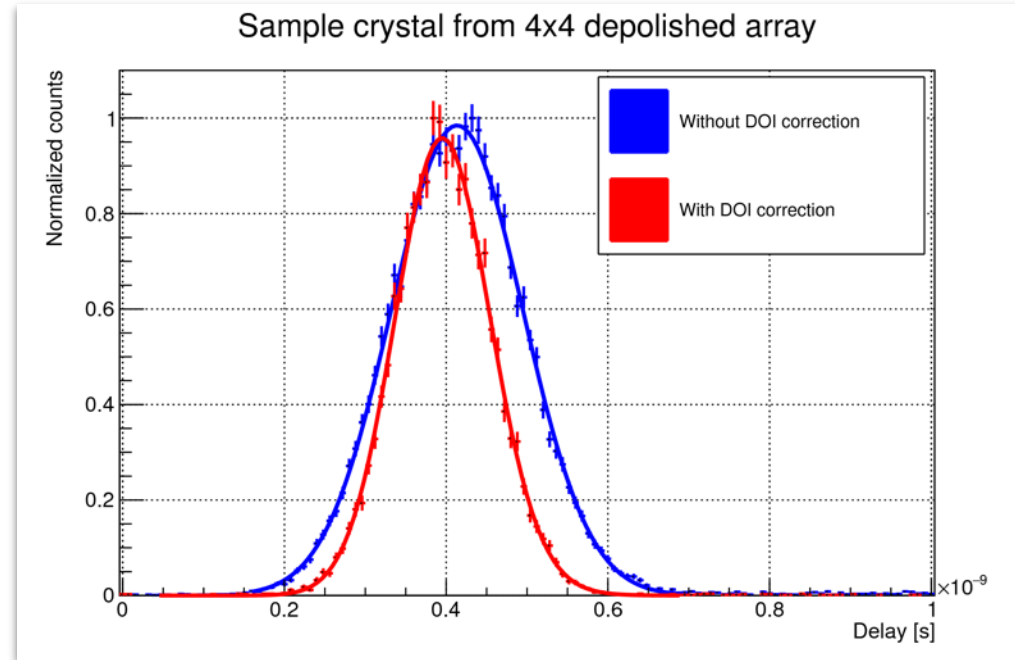
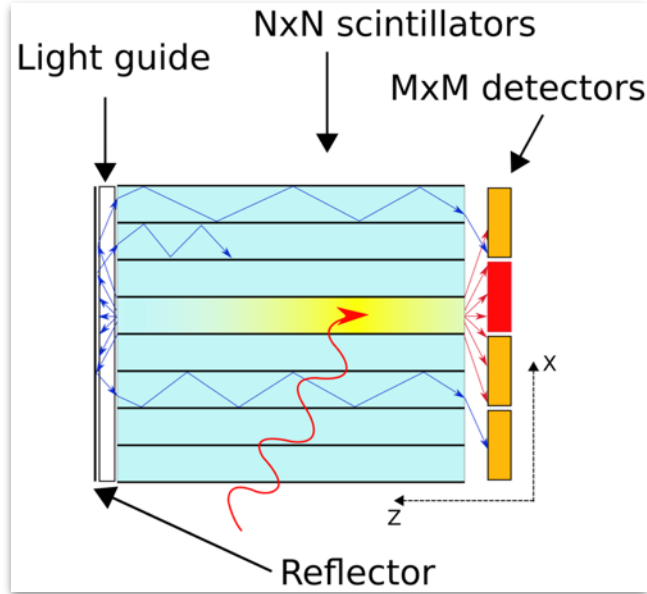


Webpage SIEMENS:

[https://static.healthcare.siemens.com/siemens\\_hwem-hwem\\_sxxa\\_websites-context-root/wcm/idc/groups/public/@global/@imaging/@molecular/documents/download/mda4/mzmy/~edisp/biograph\\_vision\\_technical\\_flyer-05440720.pdf](https://static.healthcare.siemens.com/siemens_hwem-hwem_sxxa_websites-context-root/wcm/idc/groups/public/@global/@imaging/@molecular/documents/download/mda4/mzmy/~edisp/biograph_vision_technical_flyer-05440720.pdf)

[See presentation KT/EP seminar 6 September 2021 from Maurizio Conti](#)

# In the CERN Crystal Clear group: <160 ps with DOI



Type of array	Crystals dim. [mm <sup>3</sup> ]	DOI resolution FWHM [mm]	En. Res. FWHM @ 511 keV [%]	CTR FWHM [ps], central pixels	
				<i>No correction</i>	<i>With DOI correction</i>
DOI	3.1 x 3.1 x 15	3.0 ± 0.1	8.9 ± 0.2	234 ± 2	157 ± 2

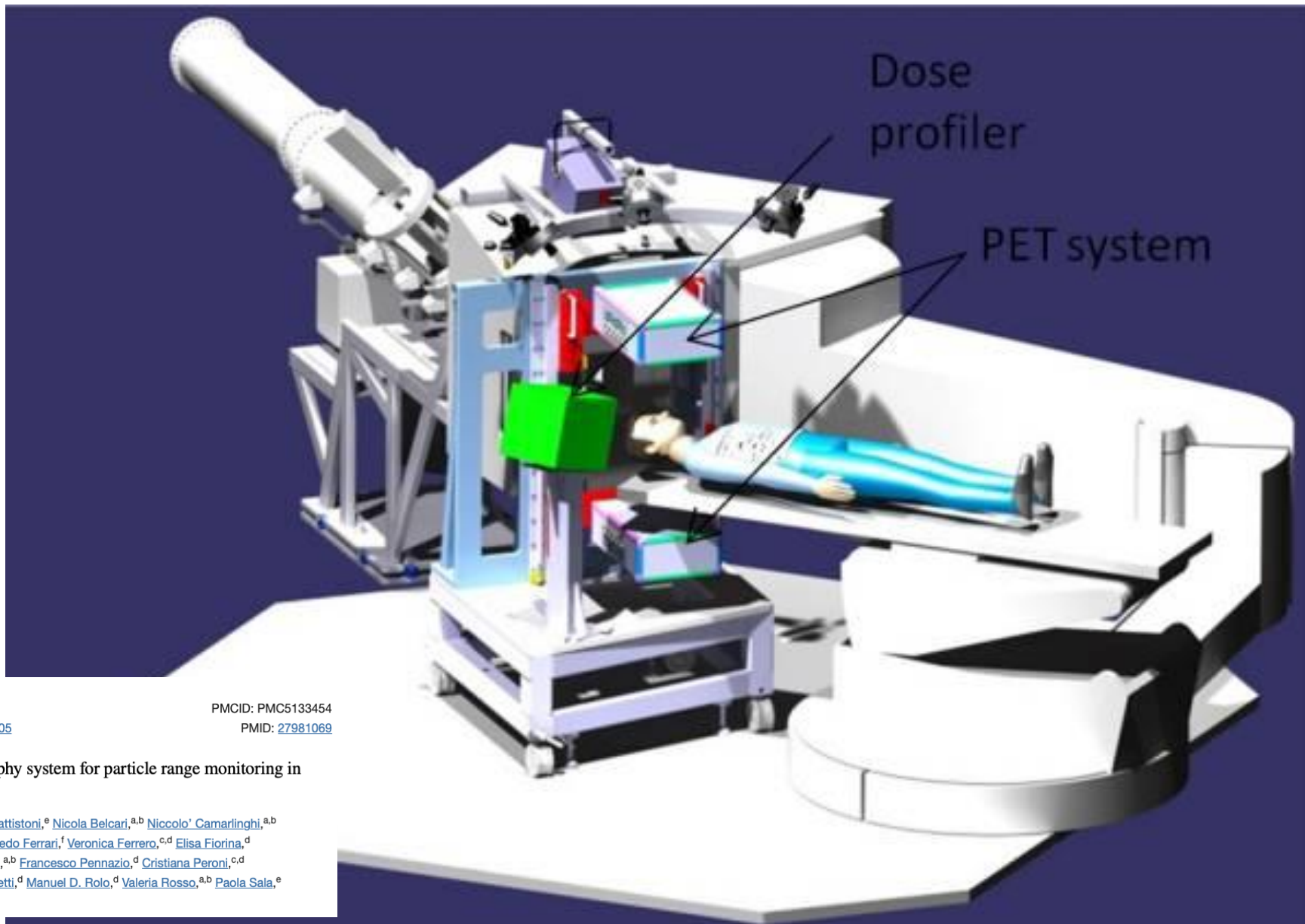
DOI information extracted without degradation of timing properties

*M. Pizzichemi et al, Phys. Med. Biol. 61 (2016) 4679*

■ PET DETECTOR



  
ENVISION



[J Med Imaging \(Bellingham\)](#), 2017 Jan; 4(1): 011005.  
Published online 2016 Dec 2. doi: [10.1117/1.JMI.4.1.011005](https://doi.org/10.1117/1.JMI.4.1.011005)

PMCID: PMC5133454  
PMID: [27981069](https://pubmed.ncbi.nlm.nih.gov/27981069/)

### INSIDE in-beam positron emission tomography system for particle range monitoring in hadrontherapy

[Maria Giuseppina Bisogni](#),<sup>a,b,\*</sup> [Andrea Attili](#),<sup>c,d</sup> [Giuseppe Battistoni](#),<sup>e</sup> [Nicola Belcarì](#),<sup>a,b</sup> [Niccolo' Camarlinghi](#),<sup>a,b</sup> [Piergiorgio Cerello](#),<sup>d</sup> [Silvia Coli](#),<sup>d</sup> [Alberto Del Guerra](#),<sup>a,b</sup> [Alfredo Ferrari](#),<sup>f</sup> [Veronica Ferrero](#),<sup>c,d</sup> [Elisa Fiorina](#),<sup>d</sup> [Giuseppe Giraud](#),<sup>d</sup> [Eleftheria Kostara](#),<sup>b</sup> [Matteo Morrocchi](#),<sup>a,b</sup> [Francesco Pennazio](#),<sup>d</sup> [Cristiana Peroni](#),<sup>c,d</sup> [Maria Antonietta Piliero](#),<sup>a,b</sup> [Giovanni Pirrone](#),<sup>a,b</sup> [Angelo Rivetti](#),<sup>d</sup> [Manuel D. Rolo](#),<sup>d</sup> [Valeria Rosso](#),<sup>a,b</sup> [Paola Sala](#),<sup>e</sup> [Giancarlo Sportelli](#),<sup>a,b</sup> and [Richard Wheadon](#)<sup>d</sup>

# Radioisotopes



# Radioisotopes: The medical testing crisis

With a serious shortage of medical isotopes looming, innovative companies are exploring ways to make them without nuclear reactors.

Richard Van Noorden

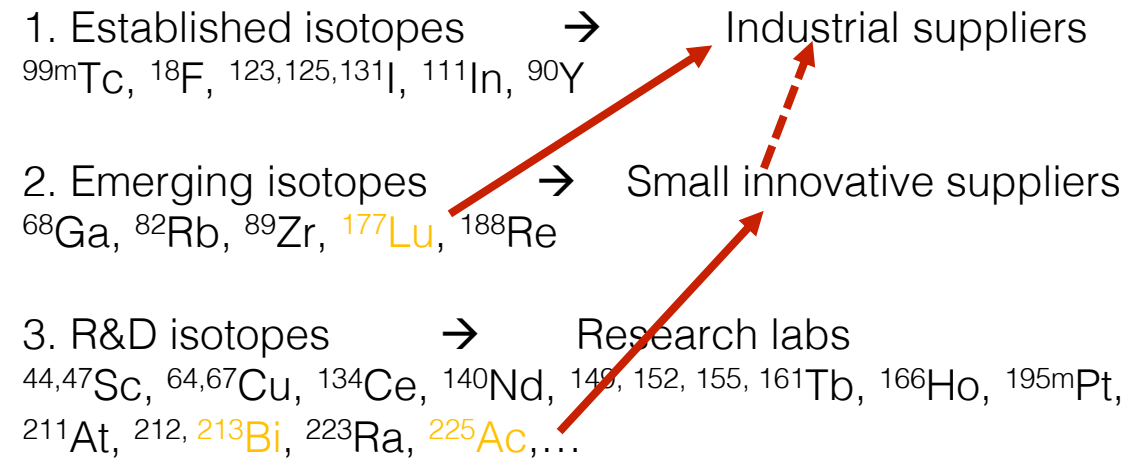
11 December 2013

PDF Rights & Permissions

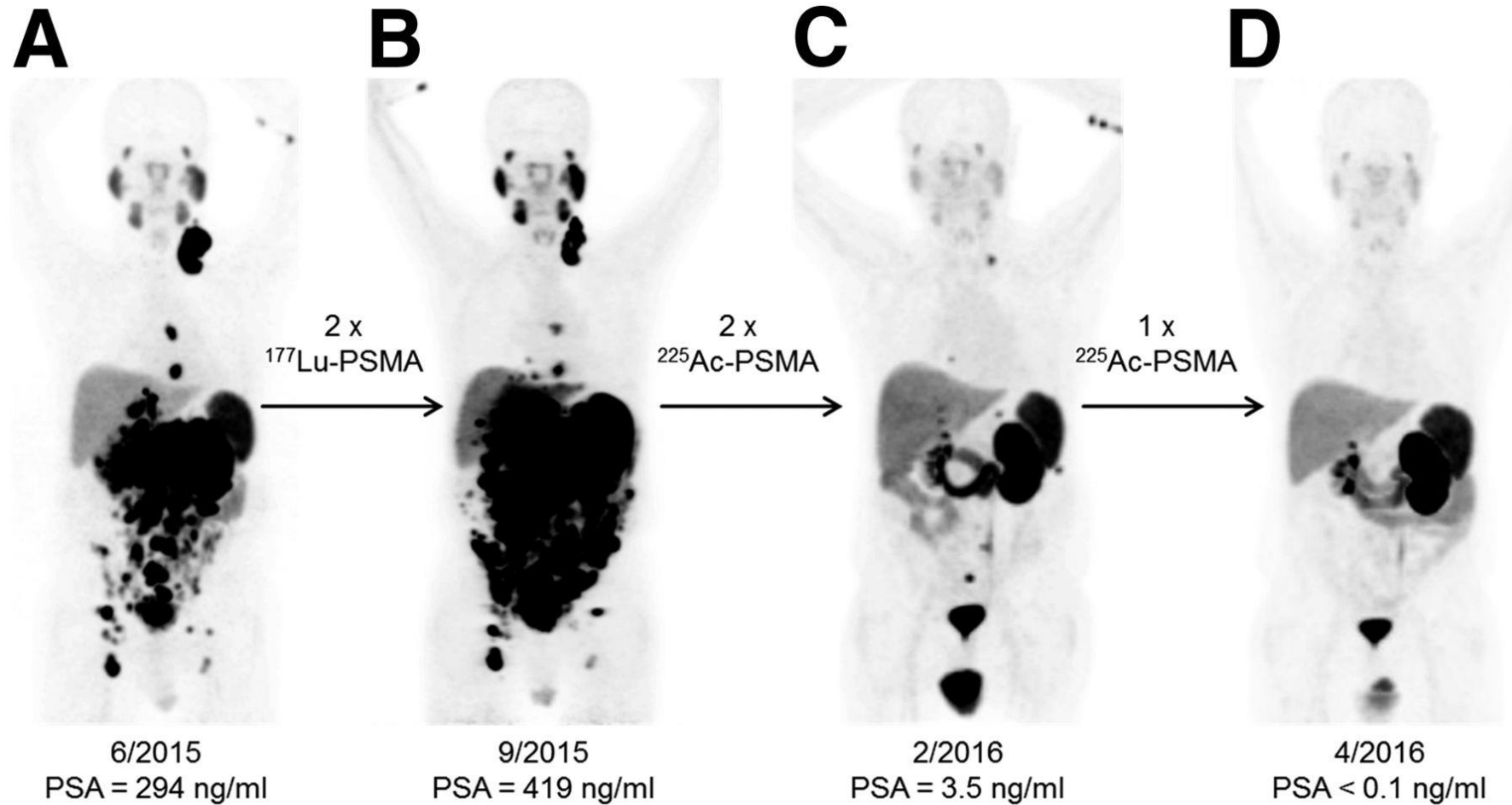


# Radioisotopes & Nuclear Medicine

## Classification of isotopes for Medicine:



Courtesy U. Koester



68Ga-PSMA-11 PET/CT scans of patient B. In comparison to initial tumor spread (A), restaging after 2 cycles of  $\beta$ -emitting  $^{177}\text{Lu-PSMA}$ -617 presented progression (B).

Clemens Kratochwil et al. J Nucl Med 2016;57:1941-1944

# Theranostics

<p><b>Tb 149</b></p> <p>4.2 m    4.1 h</p> <p>ε β<sup>+</sup> α 3.99 γ 796; 165...</p> <p>ε α 3.97 β<sup>+</sup> 1.8 γ 352; 165...</p>	<p><b>Tb 152</b></p> <p>4.2 m    17.5 h</p> <p>ly 283; 160... ε; β<sup>+</sup>... γ 344; 411...</p> <p>ε β<sup>+</sup> 2.8... γ 344; 586; 271...</p>
<p><b>Tb 155</b></p> <p>5.32 d</p> <p>ε γ 87; 105;... 180, 262</p>	<p><b>Tb 161</b></p> <p>6.90 d</p> <p>β<sup>-</sup> 0.5; 0.6... γ 26; 49; 75... e<sup>-</sup></p>



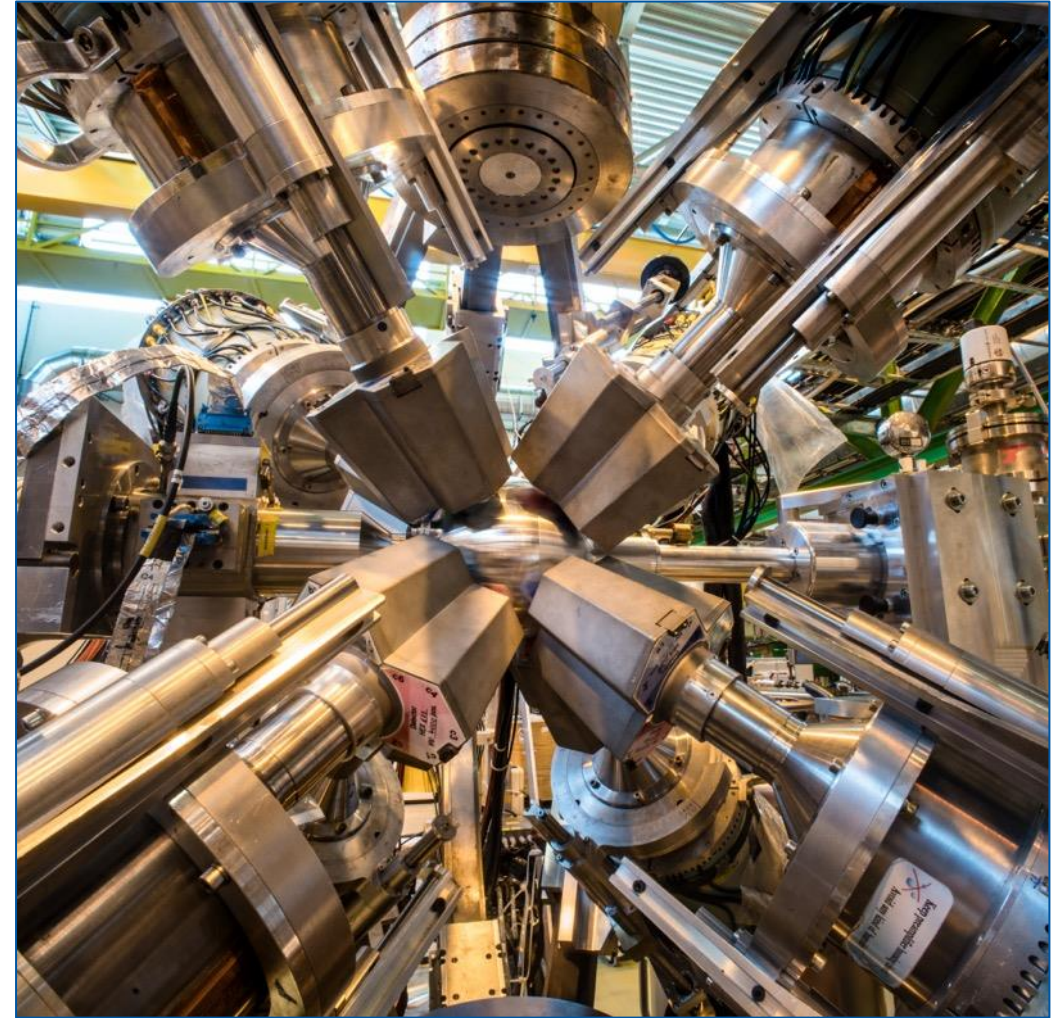
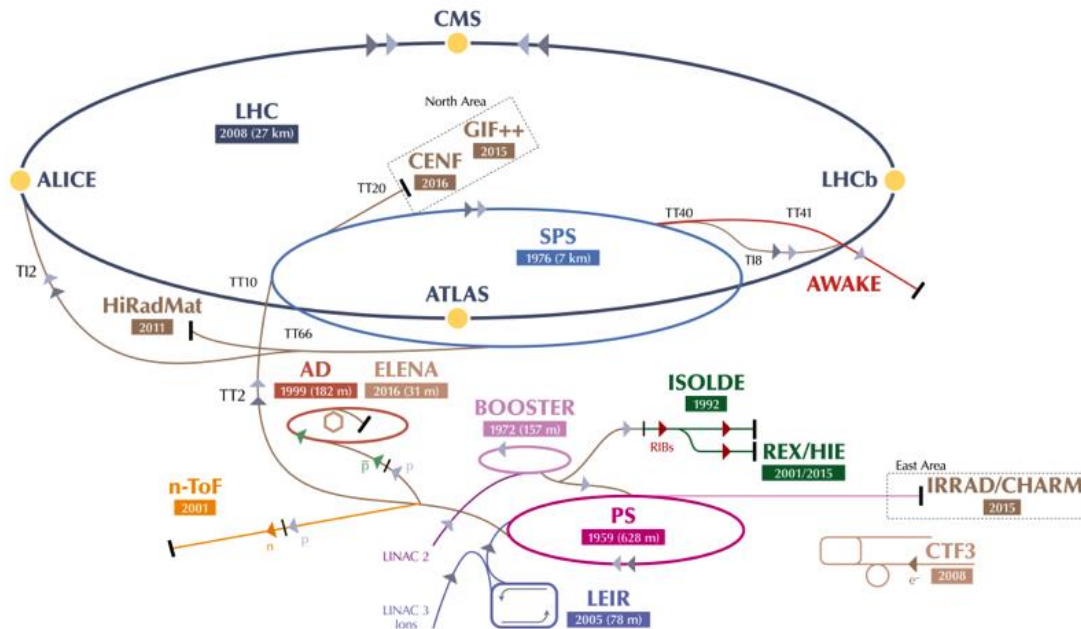
A Unique Matched Quadruplet of Terbium Radioisotopes for PET and SPECT and for α- and β-Radionuclide Therapy: An In Vivo Proof-of-Concept Study with a New Receptor-Targeted Folate Derivative

Cristina Müller, Konstantin Zhernosekov, Ulli Köster, Karl Johnston, Holger Dorrer, Alexander Hohn, Nico T. van der Walt, Andreas Türler and Roger Schibli

Journal of Nuclear Medicine December 2012, 53 (12) 1951-1959; DOI: <https://doi.org/10.2967/jnumed.112.107540>



# ISOLDE has been running @CERN for > 50 years

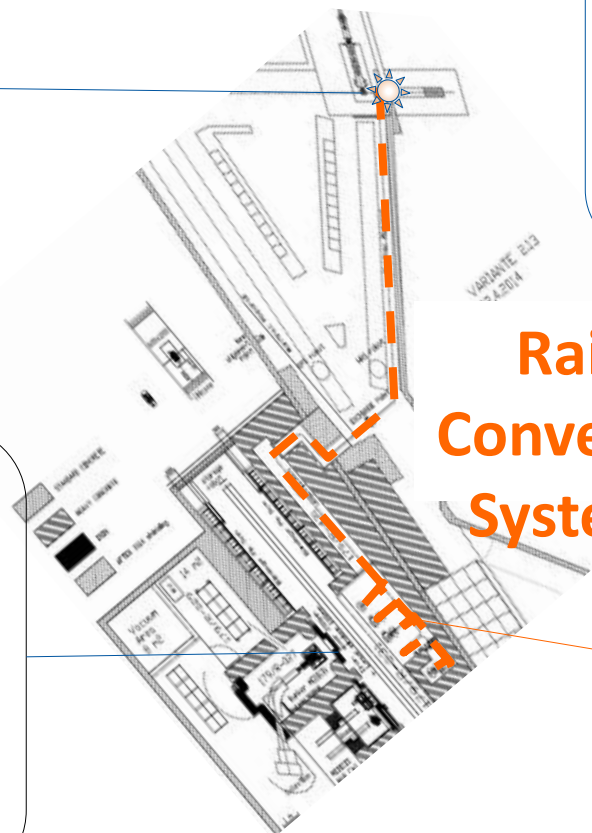
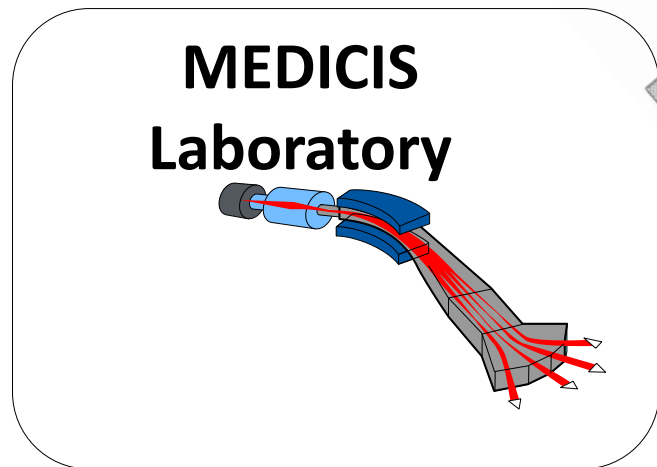
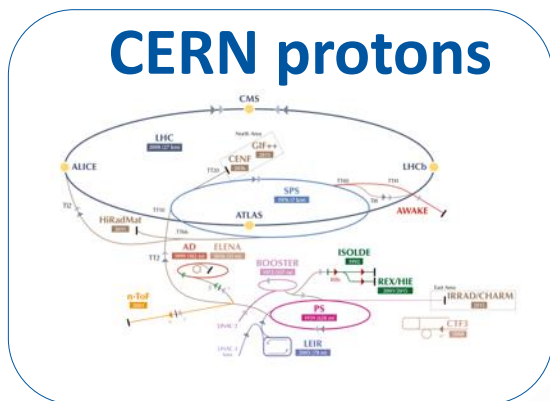


# CERN-MEDICIS

Non-conventional isotopes collected by mass separation for new medical applications



# Principle of isotope production



Rail  
Conveyor  
System

### MEDICIS Target Irradiation



ORIGINAL RESEARCH

Open Access

# Internal radiation dosimetry of a $^{152}\text{Tb}$ -labeled antibody in tumor-bearing mice



Francesco Cicone<sup>1\*</sup>, Silvano Gnesin<sup>2</sup>, Thibaut Denoël<sup>1</sup>, Thierry Stora<sup>3</sup>, Nicholas P. van der Meulen<sup>4,5</sup>, Cristina Müller<sup>4</sup>, Christiaan Vermeulen<sup>4</sup>, Martina Benešová<sup>4</sup>, Ulli Köster<sup>6</sup>, Karl Johnston<sup>3</sup>, Ernesto Amato<sup>7</sup>, Lucrezia Auditore<sup>7</sup>, George Coukos<sup>8</sup>, Michael Stabin<sup>9</sup>, Niklaus Schaefer<sup>1</sup>, David Viertl<sup>1</sup> and John O. Prior<sup>1</sup>

RN from CERN-ISOLDE & CERN-MEDICIS  
Conjoint work between CERN-ILL-PSI-CHUV

Research Topic

## MEDICIS-Promed: Advances in Radioactive Ion Beams for Nuclear Medicine

LOGIN / REGISTER

Topical issue in *Frontiers in Medicine*  
>20 manuscripts being submitted  
(ca 10 with MEDICIS results)

# SCIENTIFIC REPORTS

OPEN

## Chemical Purification of Terbium-155 from Pseudo-Isobaric Impurities in a Mass Separated Source Produced at CERN

Received: 24 April 2019  
Accepted: 11 July 2019  
Published online: 26 July 2019

Ben Webster<sup>1,2</sup>, Peter Ivanov<sup>1</sup>, Ben Russell<sup>1</sup>, Sean Collins<sup>1</sup>, Thierry Stora<sup>3</sup>, Joao Pedro Ramos<sup>3,4</sup>, Ulli Köster<sup>5</sup>, Andrew Paul Robinson<sup>1,6,7</sup> & David Read<sup>1,2</sup>

RN from CERN-ISOLDE & CERN-MEDICIS  
Conjoint work between CERN-NPL-ILL-University of Manchester

# Radiation-detected Nuclear Magnetic Resonance

Development of [a new medical diagnostic modality](#)

NMR is versatile and powerful but not sensitive due to:

- Small degree of spin polarization

- Inefficient detection

Our combined paths to increase sensitivity => radiation-detected NMR:

- (Hyper)polarisation of spins

- Detection of asymmetry in decay radiation

# Radiation-detected Nuclear Magnetic Resonance

Development of [a new medical diagnostic modality](#)

NMR is versatile and powerful but not sensitive due to:

- Small degree of spin polarization

- Inefficient detection

Our combined paths to increase sensitivity => radiation-detected NMR:

- Up to 10 orders of magnitude more sensitive than conventional NMR/MRI;
- & Up to 5 orders of magnitude more sensitive than hyperpolarised NMR/MRI

### $\beta$ -NMR, betaDropNMR:

ERC Starting Grant

ERC Proof of Concept application

1	1 H	
2	3 Li	4 Be
3	11 Na	12 Mg
4	19 K	20 Ca
5	37 Rb	38 Sr
6	55 Cs	56 Ba
7	87 Fr	88 Ra

Already polarized or Planned

21 Sc	22 Ti	23 V	24 Cr	25 Mn	26 Fe	27 Co	28 Ni	29 Cu	30 Zn	31 Ga	32 Ge	33 As	34 Se	35 Br	36 Kr
39 Y	40 Zr	41 Nb	42 Mo	43 Tc	44 Ru	45 Rh	46 Pd	47 Ag	48 Cd	49 In	50 Sn	51 Sb	52 Te	53 I	54 Xe
71 Lu	72 Hf	73 Ta	74 W	75 Re	76 Os	77 Ir	78 Pt	79 Au	80 Hg	81 Tl	82 Pb	83 Bi	84 Po	85 At	86 Rn
103 Lr	104 Rf	105 Db	106 Sg	107 Bh	108 Hs	109 Mt	110 Ds	111 Rg							
57 La	58 Ce	59 Pr	60 Nd	61 Pm	62 Sm	63 Eu	64 Gd	65 Tb	66 Dy	67 Ho	68 Er	69 Tm	70 Yb		
89 Ac	90 Th	91 Pa	92 U	93 Np	94 Pu	95 Am	96 Cm	97 Bk	98 Cf	99 Es	100 Fm	101 Md	102 No		

\* Lanthanides

\*\* Actinides

### $\beta$ -NMR, PreSOBEN:

ERC Consolidator Grant

### RD-ZULF-NMR (with Mainz):

Patent applications filed

CERN MA project, 2022-

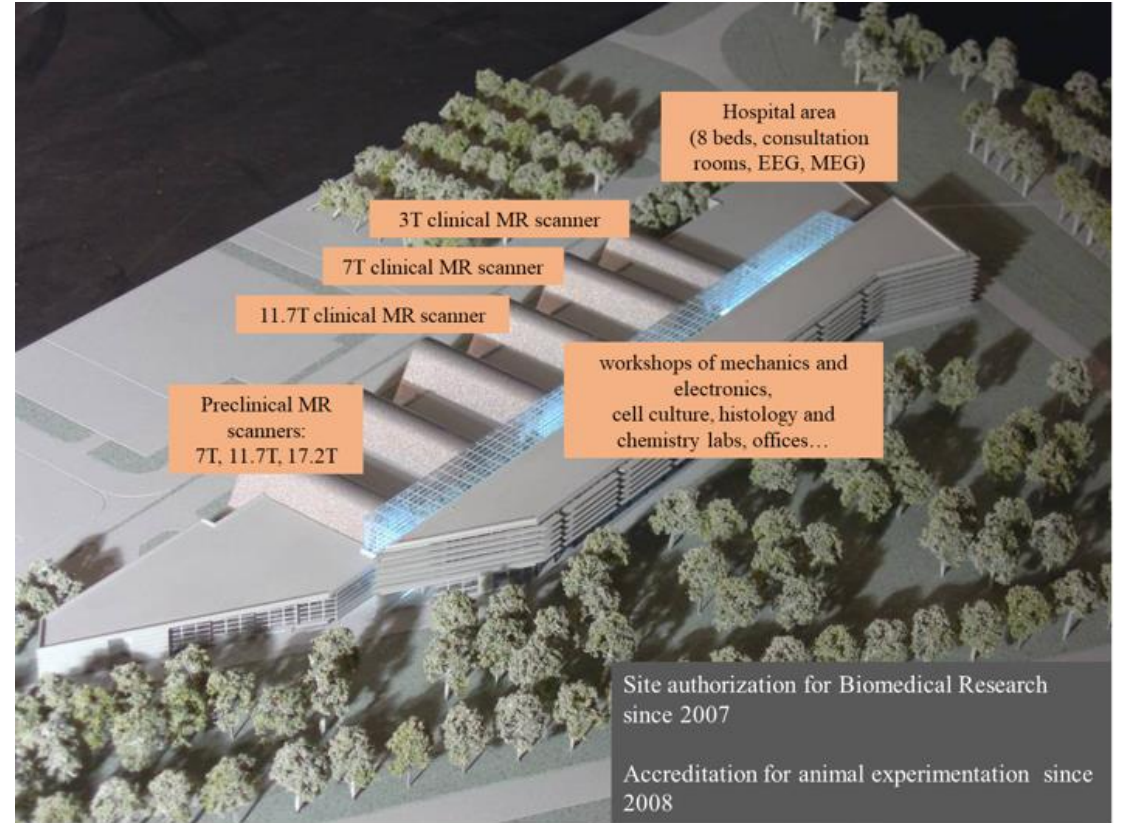
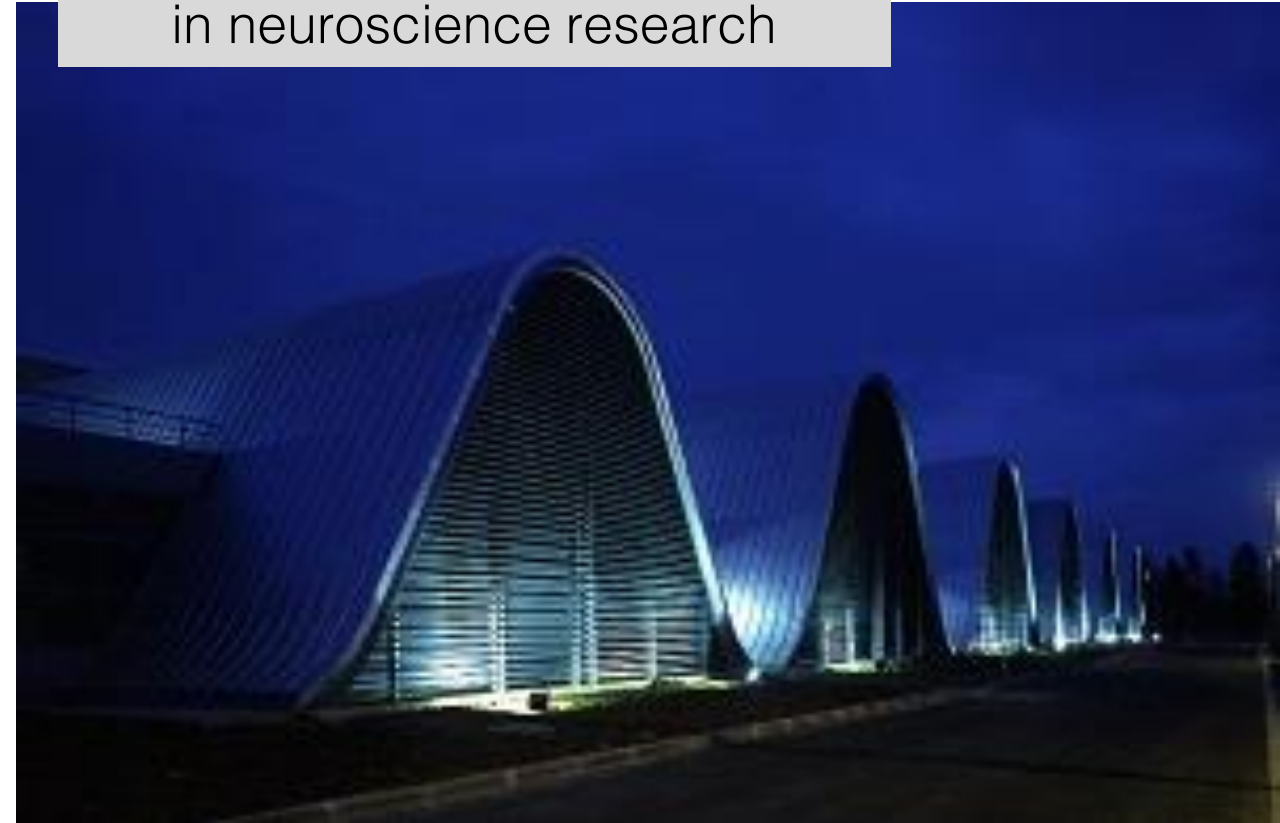
### $\gamma$ -MRI (with Geneva, Madrid,

Leuven, Strasbourg, Maastricht):

CERN MA project, 2017-2021

EU FET-Open project, 2022-

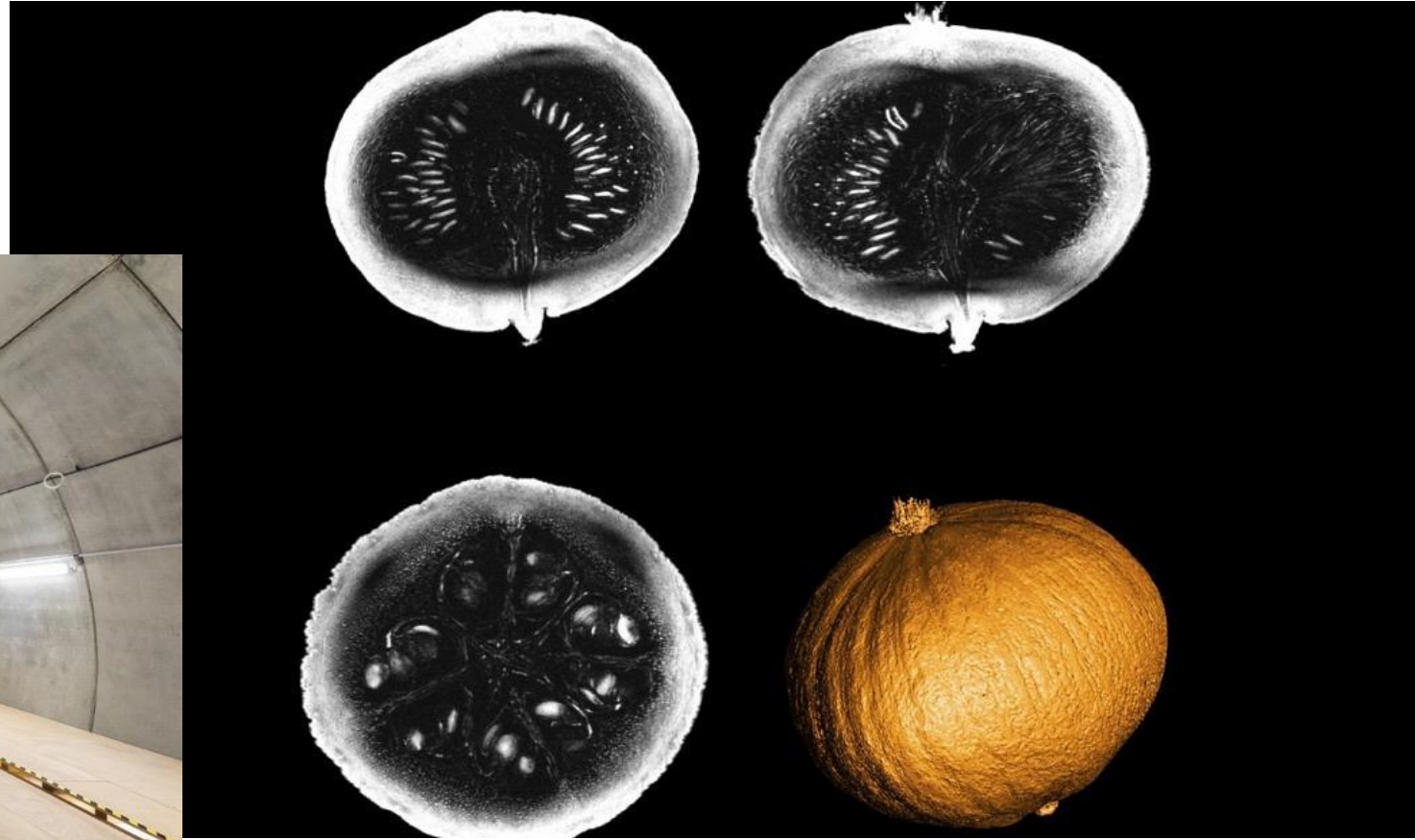
NEUROSPIN: a unique concept  
in neuroscience research





The ISEULT magnet - a French-German initiative

Full field of 11.72 teslas achieved on July 18, 2019



First images released  
Oct. 7, 2021

# Digital Technologies

```
elif operation == "MIRROR_Y":
    mirror_mod.use_x = False
    mirror_mod.use_y = True
    mirror_mod.use_z = False
elif operation == "MIRROR_Z":
    mirror_mod.use_x = False
    mirror_mod.use_y = False
    mirror_mod.use_z = True

#selection at the end -add back the deselected mirror modifier object
mirror_ob.select= 1
modifier_ob.select=1
bpy.context.scene.objects.active = modifier_ob
print("Selected" + str(modifier_ob)) # modifier ob is the active ob
#mirror_ob.select = 0
#me = bpy.context.selected_objects[0]
#bpy.data.objects[me.name].select = 1
```

# Human phantoms

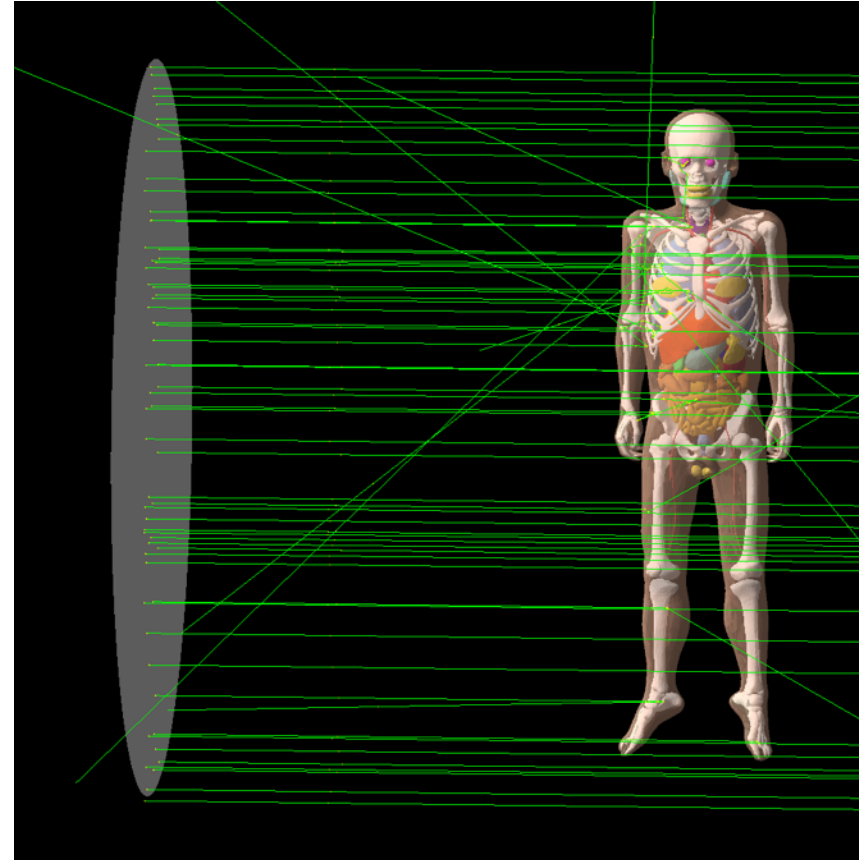
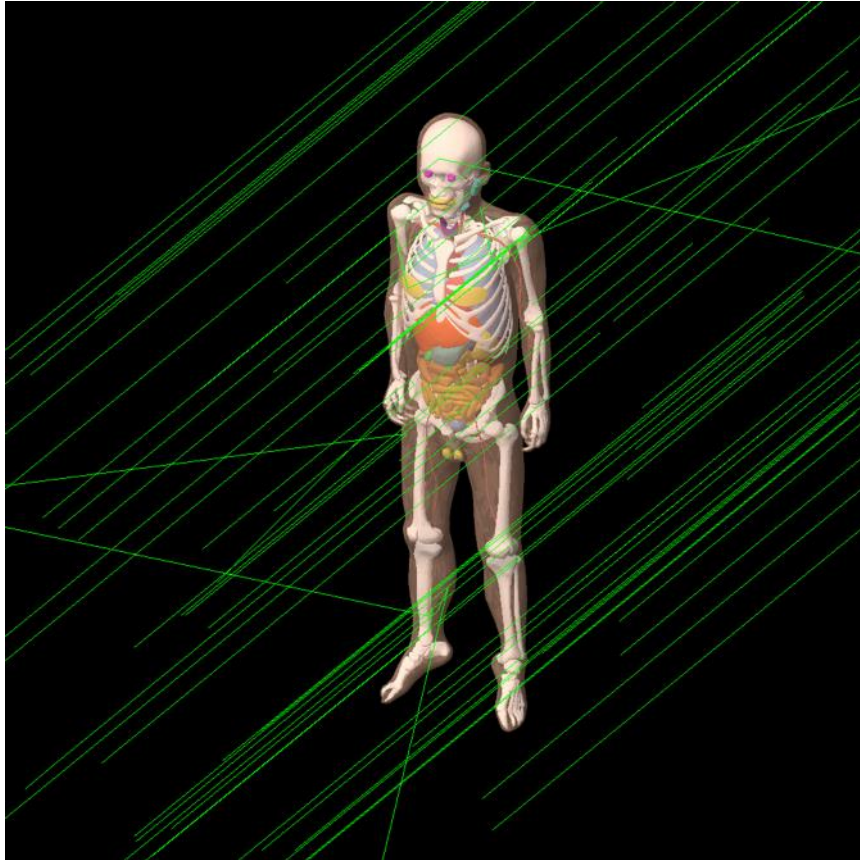
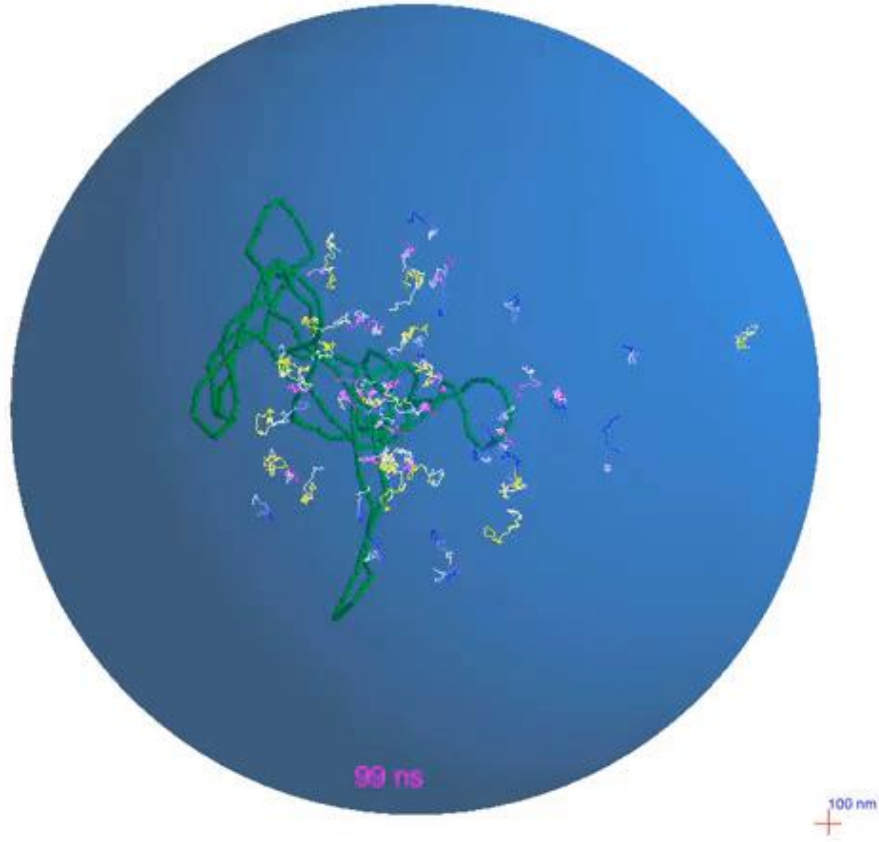


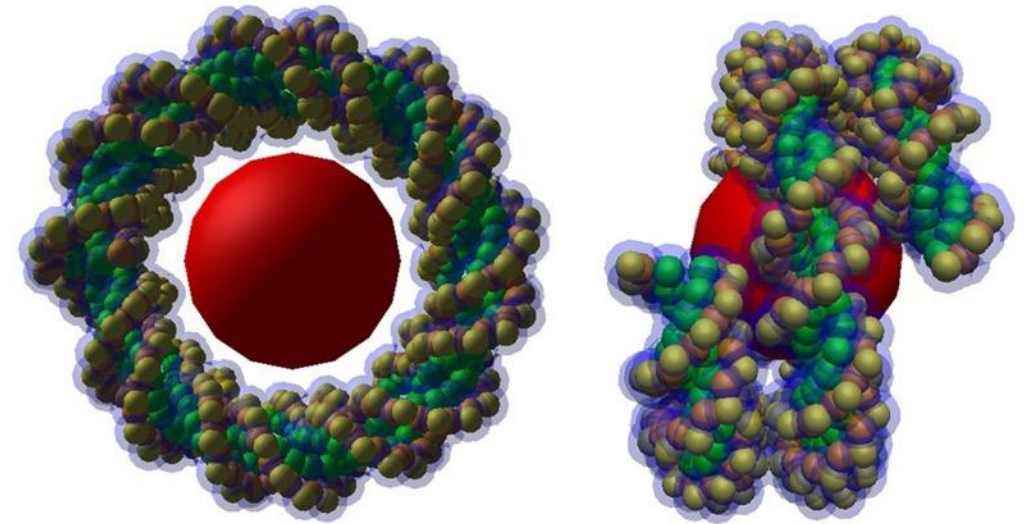
Image of Polygon-Surface Reference Korean Male Phantom (PSRK-Man), implemented in Geant4. Courtesy of C.-H. Kim & C. Choi, Hanyang Univ.

# Geant4-DNA applications

Simulation using Geant4-DNA of irradiation of a pBR322 plasmid, including radiolysis



- movie courtesy of V. Stepan (NPI-ASCR/CENBG/CNRS/IN2P3/ESA)



Model of nucleosome created using DnaFabric\*, imported into Geant4 to model irradiation, repair mechanisms.

\* S. Meylan et al, Comp. Phys. Comm. 204 (2016) p159

# Tools for specific applications

based on Geant4

Tools provide specific capabilities for creating setups, measuring

create setup, steer simulation via 'text commands'

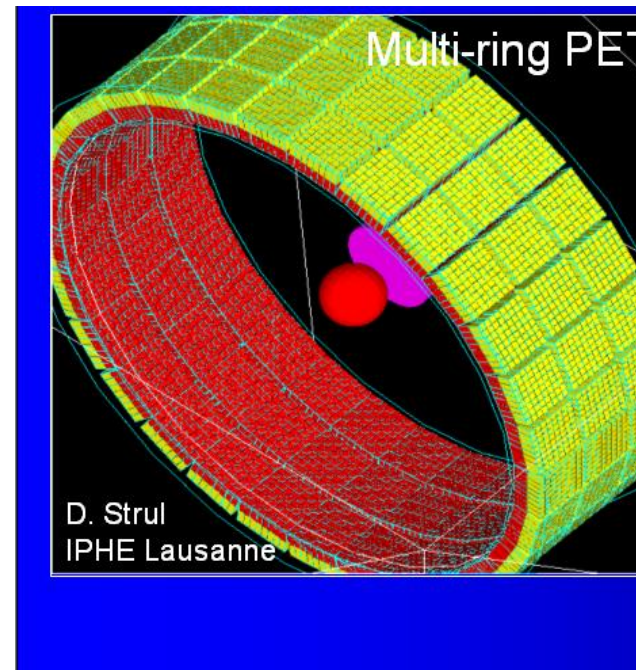
output adapted for application-area

[GATE](#) (FR, DE, GR, PL, AT) - PET/SPECT,

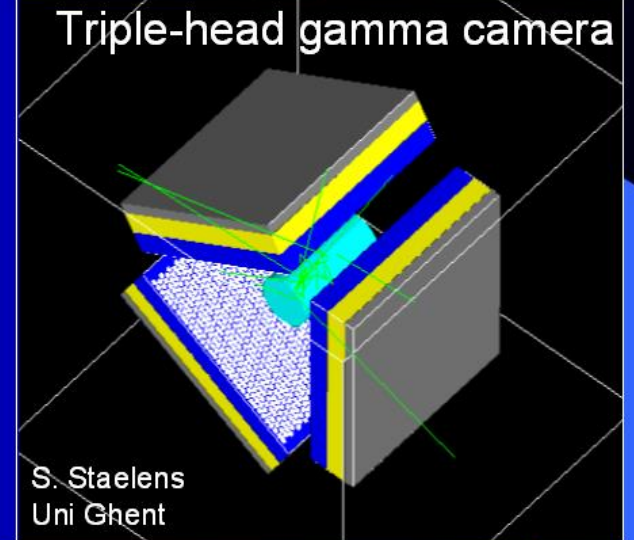
[TOPAS](#) (US) - protontherapy

[GAMOS](#) (ES) - for nuclear medicine applications

Developed by external parties - using capabilities of G4 toolkit



Example GATE geometries



**TOPAS** Tool for Particle Simulation

*To use Monte Carlo transport for radiation therapy research in the past, one had to be both an expert in Monte Carlo and an expert in medical physics. With TOPAS, it is sufficient to be an expert in medical physics or biology*

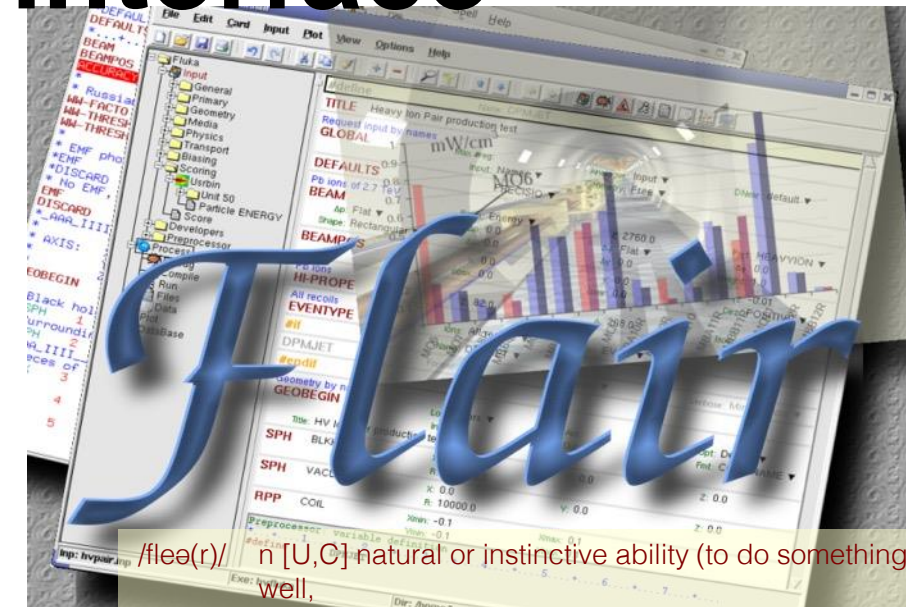
TOPAS has been developed by:  
David Hall  
Bruce Faddegon  
Aimee McNamara  
Harald Paganetti  
Joseph Perl  
Jan Schümann  
Jungwook Shin  
José Ramos

Thank You NIH !!!!

TOPAS supported by the U.S National Institutes of Health under contracts 2R01CA140735-05 and 1 R01 CA187003-01A1 and by TOPAS MC Inc

The image shows a 3D visualization of a proton therapy treatment setup. It includes a proton source, a beamline with various components like magnets and monitors, and a patient couch. The setup is shown in a 3D perspective view.

# Flair – fluka advanced interface



Improvements for medical simulations

Process DICOM standard files for radiotherapy purposes

Provides easy-to use tool for **treatment plan re-simulation** and quantitative comparison

Enables precise description of patient model and beam delivery system

*/flɛə(r)/* n [U,C] natural or instinctive ability (to do something well,  
to select or recognize what is best, more useful, etc.  
[Oxford Advanced Dictionary of Current English]

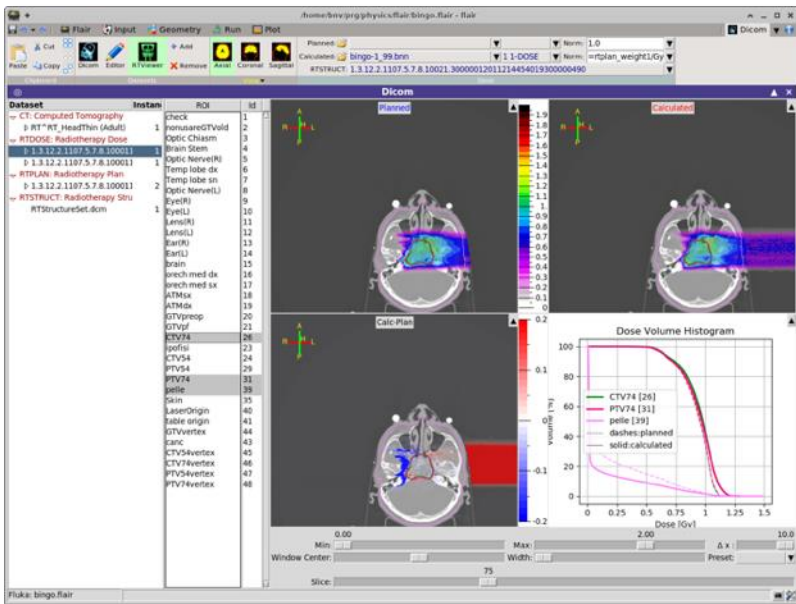
is more than a graphical Interface

→ is a complete integrated working environment for FLUKA

Greatly enhanced productivity

→ users focus on their problem rather than on technicalities

In this presentation: a selection of results obtained by the CERN group



3D spatial dose distribution simulated with FLUKA

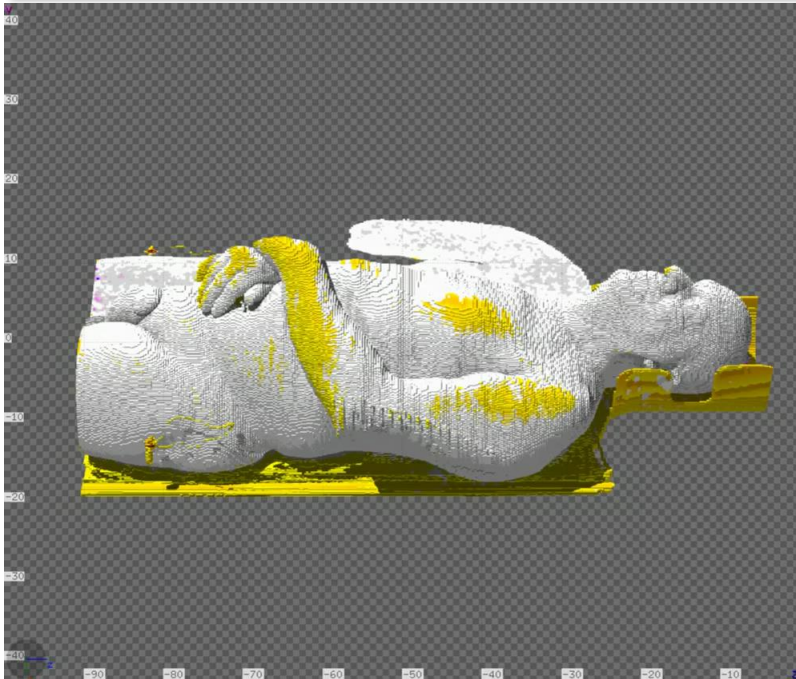
Importing the RT DOSE with the activity mapping of  $^{68}\text{Ga}$

Simulation of the  $^{68}\text{Ga}$  decays

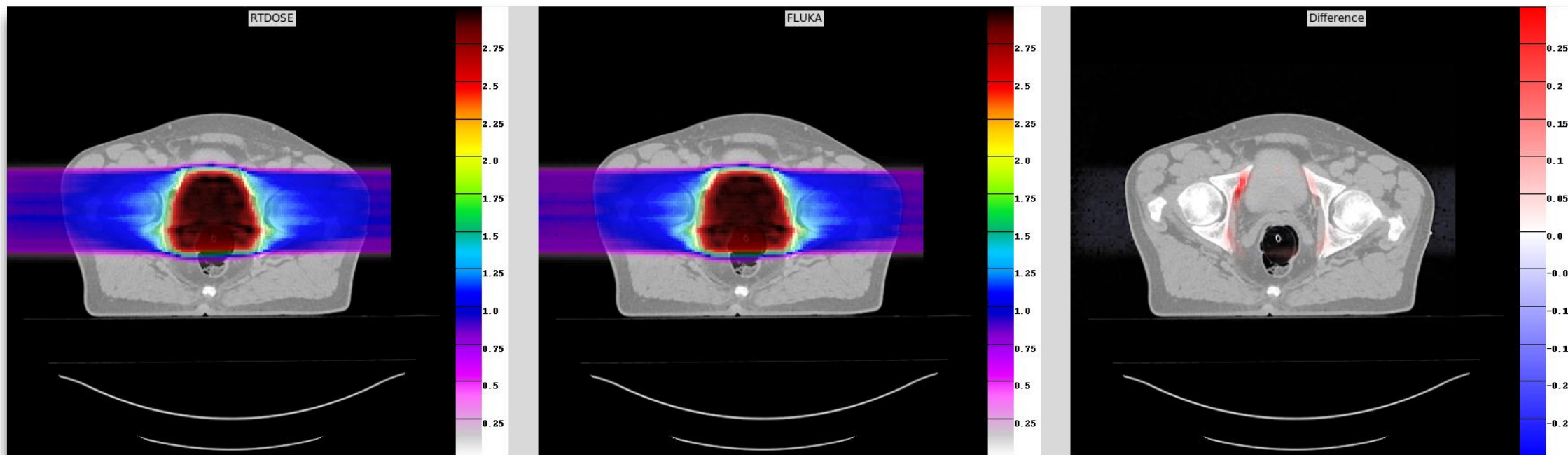
Very fast setup time

less than a few minutes with a few clicks from the user

Run FLUKA simulations with no programming skills or file editing requirements!



# Sensitivity studies of Monte Carlo TP recalculations



*Proton prostate patient case (MedAustron)  
W.Kozłowska PhD*

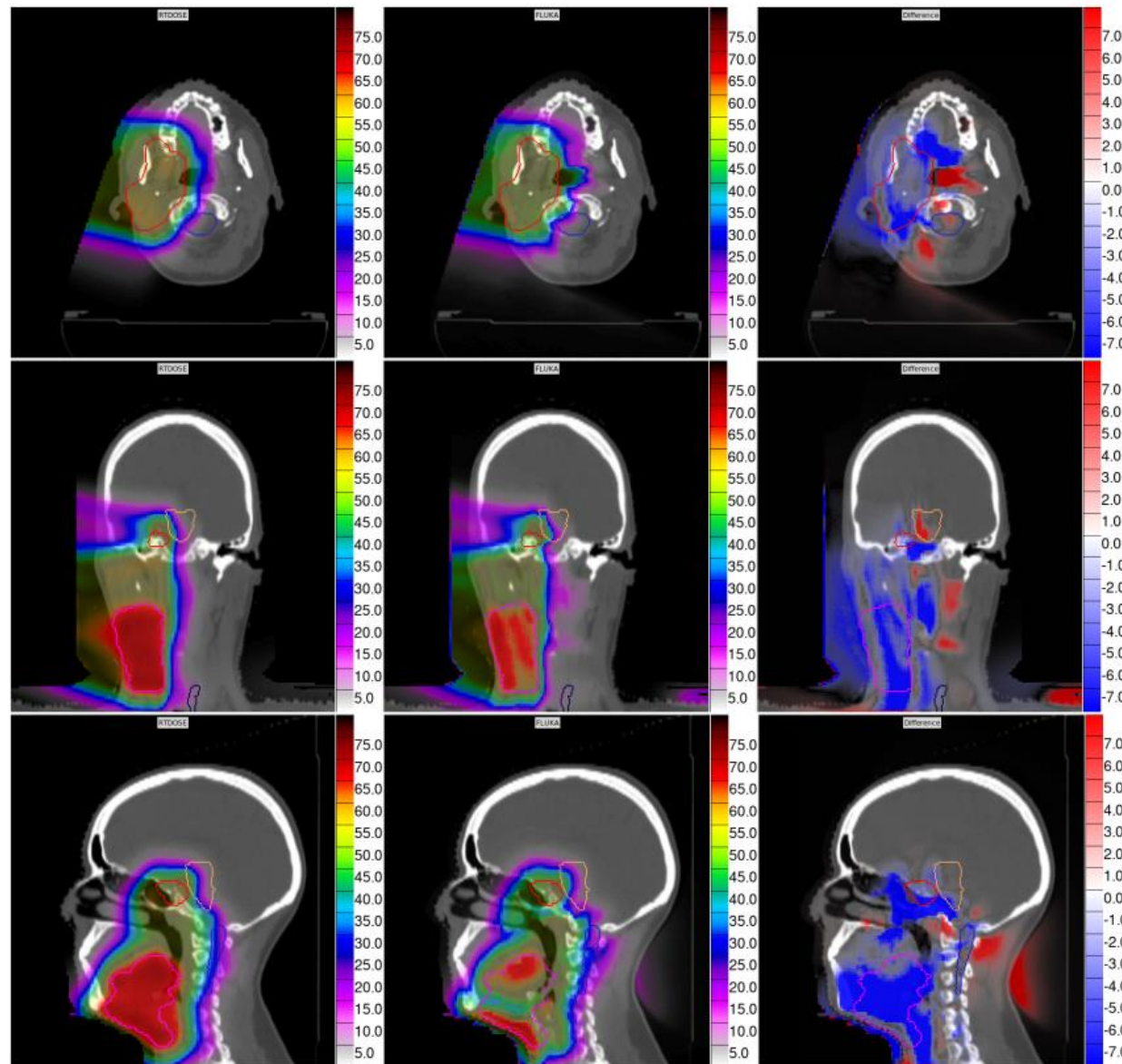
- Calibration of HU to density
- HU to tissue conversion methods
- Size of the scoring grid
- Ionization potentials of tissue materials
- Accuracy of primary beam description
- ...

One of the **major contributing factor** to radiation therapy accidents related to the TPS is the **lack of independent calculations** for beam intensities

IAEA Human Health Report No.7 Vienna (2013)

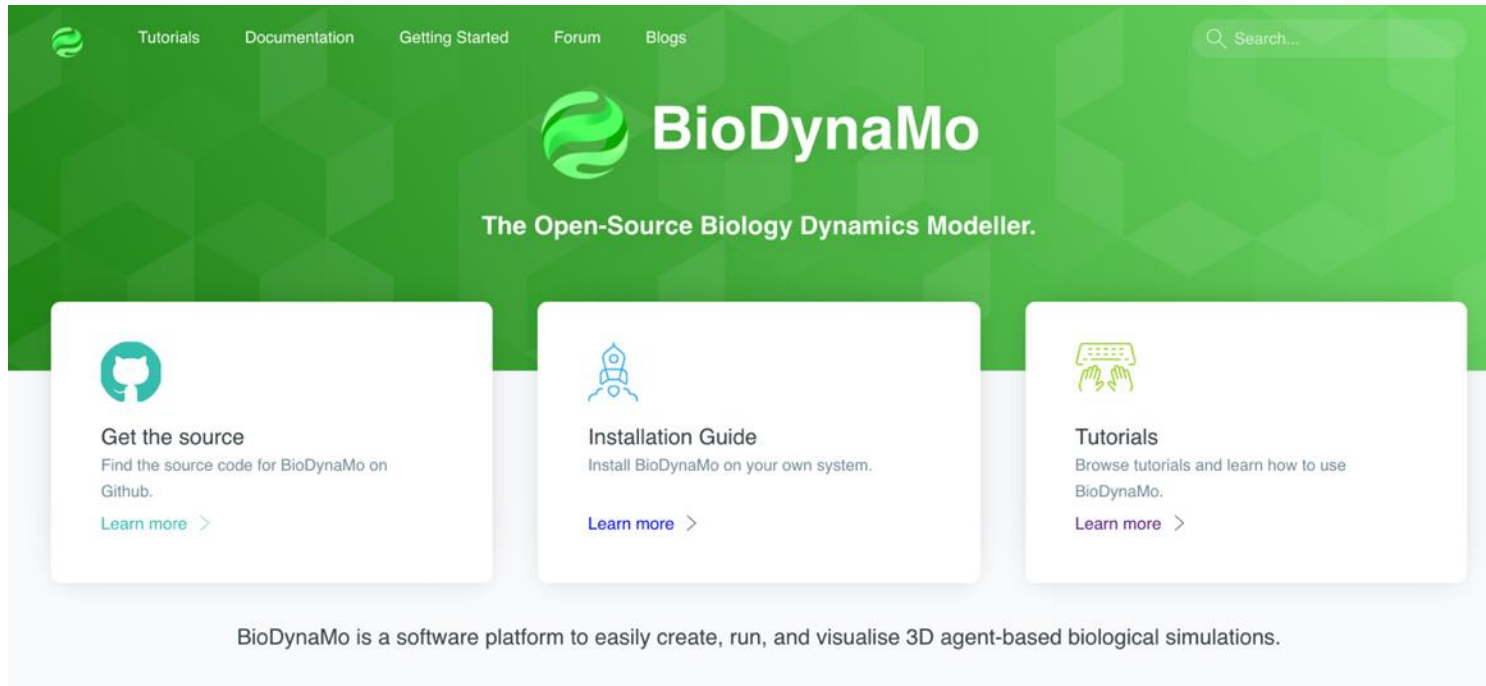


# Head and Neck case



*Head and Neck case (CNAO)  
W.Kozłowska PhD*

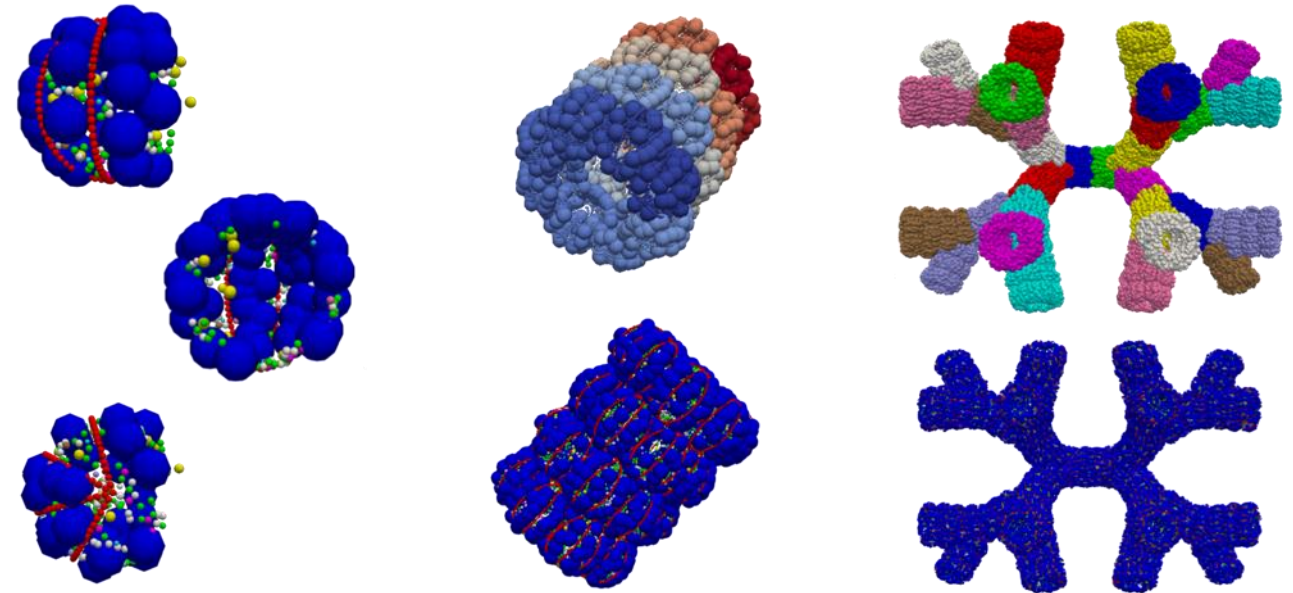
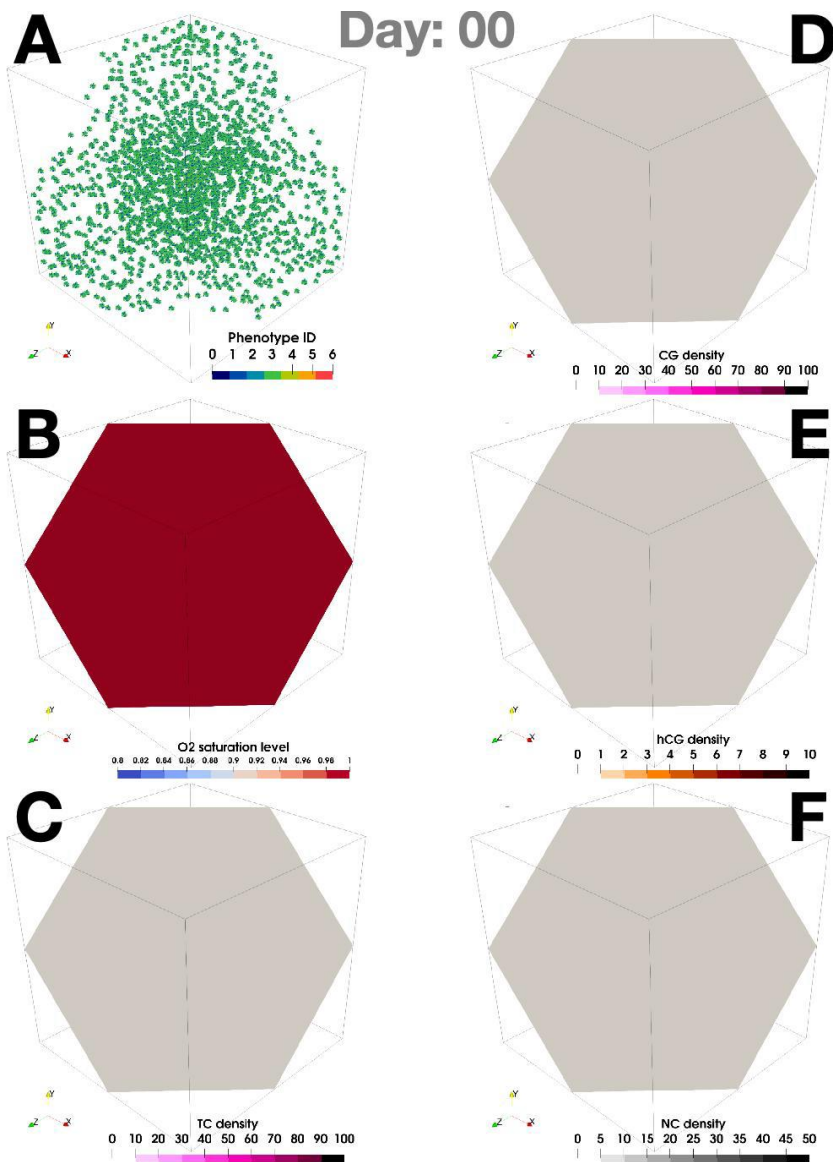
# BioDynaMo: An open-source software framework



An open-source software platform to easily create, run, and visualise 3D agent-based simulations, built up around CERN-developed technologies

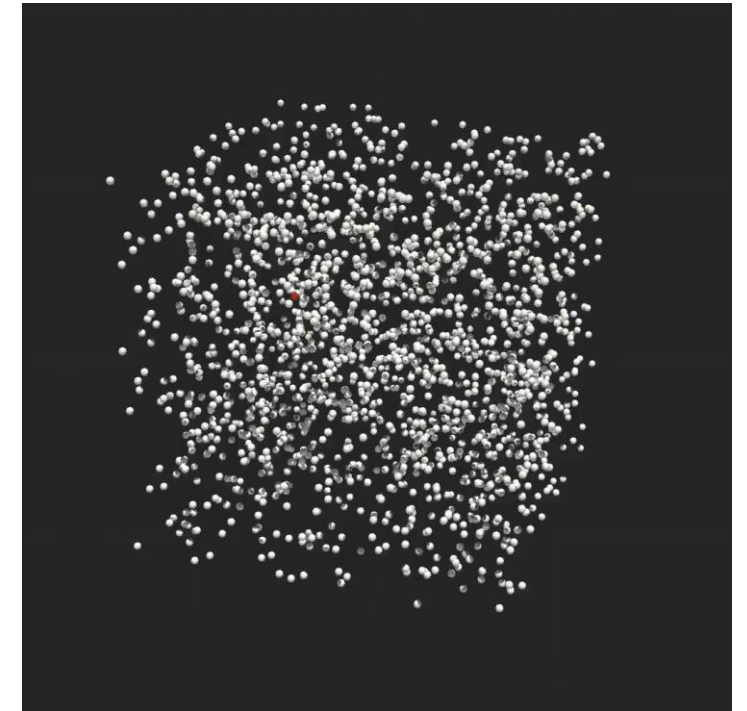
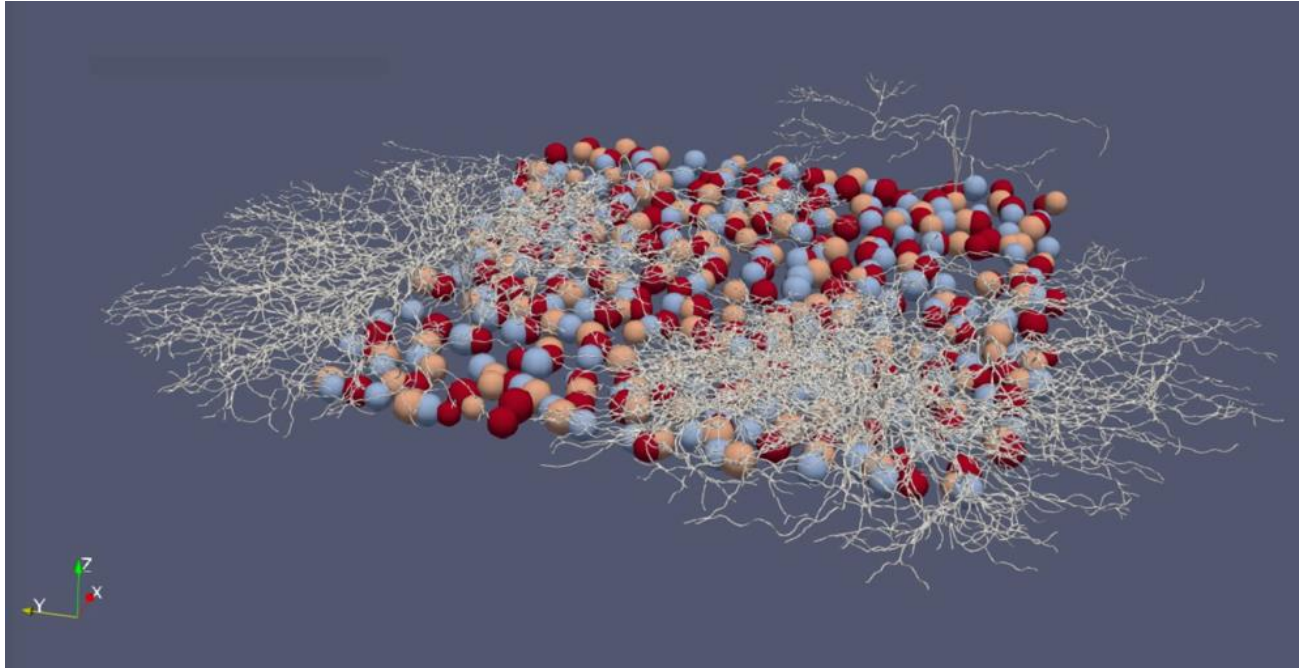
[www.biodynomo.org](http://www.biodynomo.org)





Courtesy Nicolo Cugno, TU Darmstadt (Germany)

From De Montigny et al., Methods, 2020



Courtesy Jean de Montigny and Roman Bauer

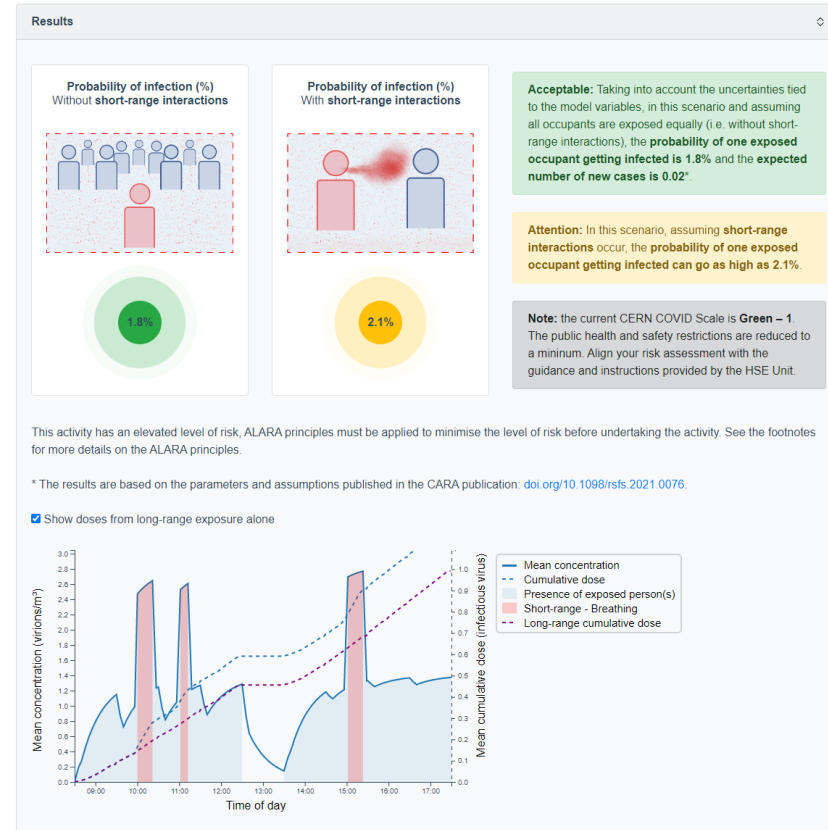


# CAiMIRA

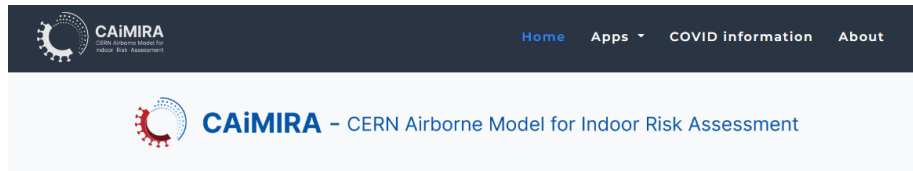
CERN Airborne Model for Indoor Risk Assessment

## What is CAiMIRA ?

- A model for estimating the risk of secondary on-site transmission, via the airborne route, of respiratory pathogens in indoor settings, using different compensatory measures (masks, ventilation, filtration, vaccination, occupancy, etc.)



Results tailored for your room



### Introduction

CAiMIRA is a risk assessment tool developed to model the concentration of viruses in enclosed spaces, in order to inform space-management decisions. It does this by simulating the airborne spread SARS-CoV-2 virus in a finite volume, assuming homogenous mixing for the long-range component and a two-stage jet model for short-range, and estimates the risk of COVID-19 airborne transmission therein. Please see the [About](#) page for more details on the methodology, assumptions and limitations of CAiMIRA. The full CAiMIRA source code can be accessed freely under an Apache 2.0 open source license from our [code repository](#). It includes detailed instructions on how to run your own version of this tool.



Apps: [Calculator](#) [Expert \(beta\)](#)

Multidisciplinary model

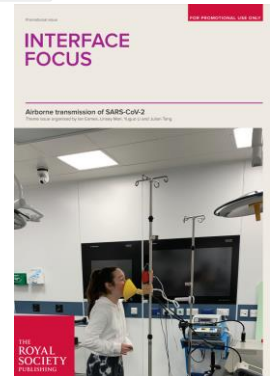
Web app [cern.ch/cara](https://cern.ch/cara)

### Research articles

## Modelling airborne transmission of SARS-CoV-2 using CARA: risk assessment for enclosed spaces

Andre Henriques✉, Nicolas Mounet, Luis Aleixo, Philip Elson, James Devine, Gabriella Azzopardi, Marco Andreini, Markus Rognlien, Nicola Tarocco and Julian Tang

Published: 11 February 2022 | <https://doi.org/10.1098/rsfs.2021.0076>



Extension to the medical field of AI tools for

functional and dependency analysis of complex critical infrastructure

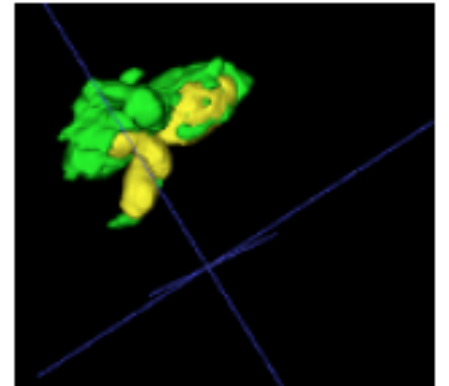
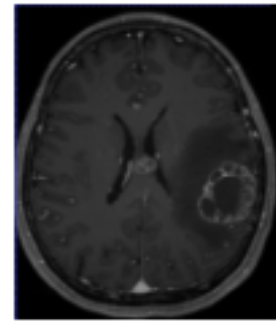
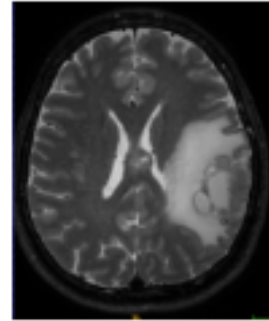
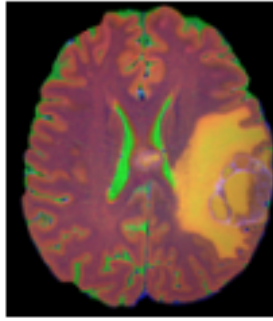
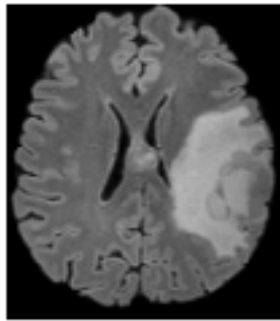
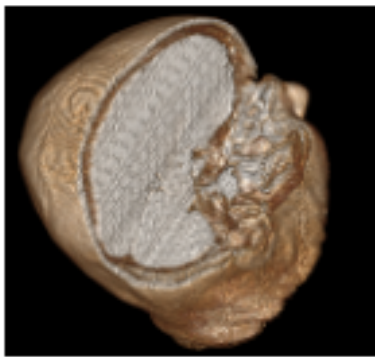
digital imaging for radiography autonomous defects detection

Background work:

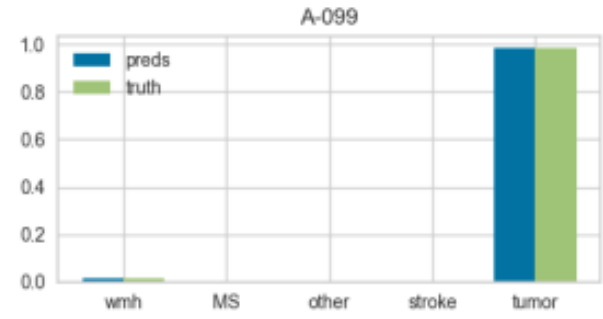
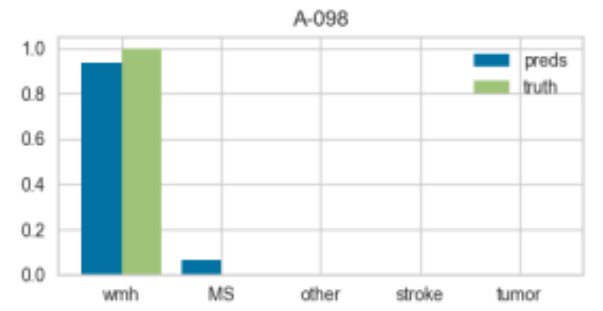
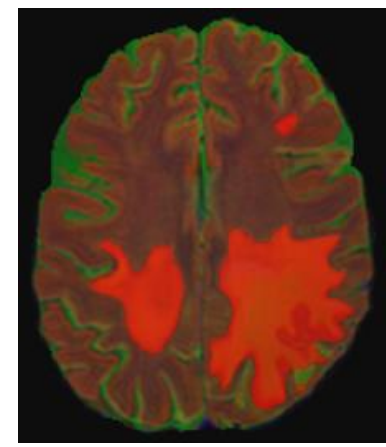
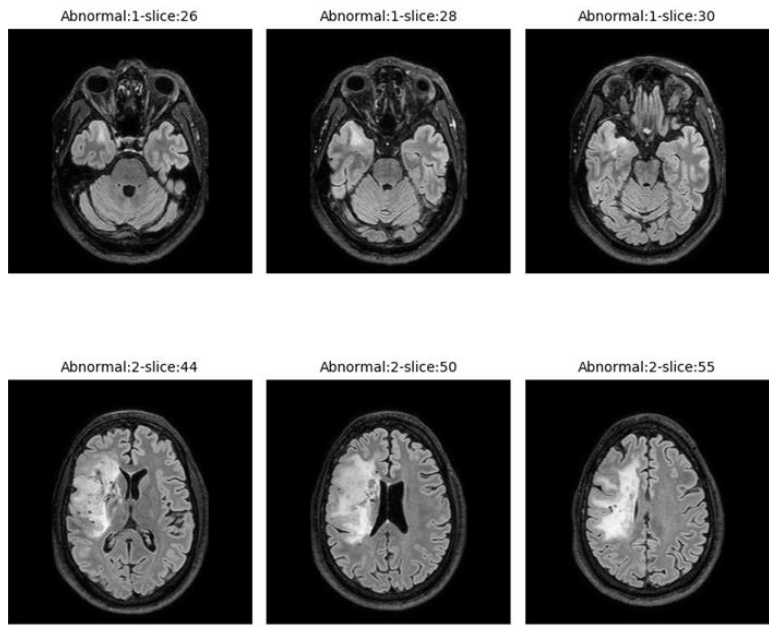
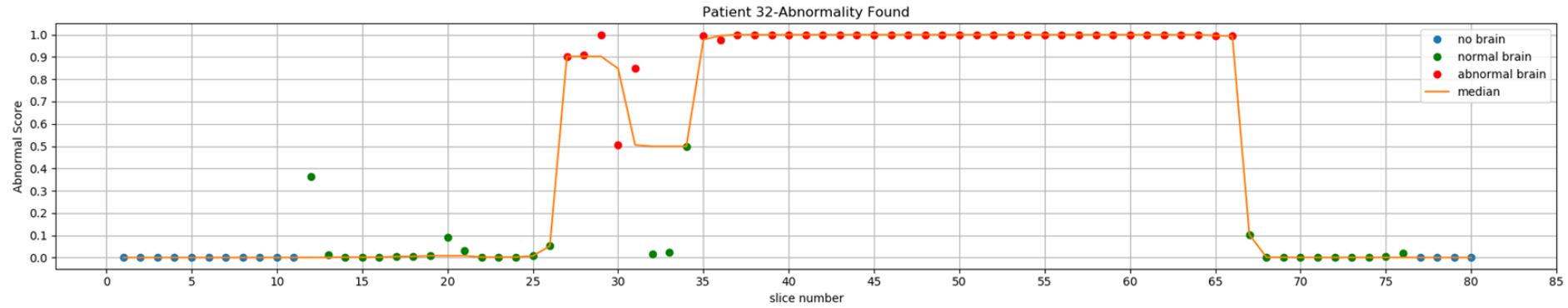
the CASO platform: AI-assisted diagnosis and predictive maintenance for critical infrastructures operation

the CAFEIN platform: AI-assisted X-ray image analysis for quality control of LHC welds

- **Field of application:**
  - Semi-automated analysis and modelling of medical data and images
  - Diagnosis and treatments based on multiple features and data beyond human perception
  - Federated learning and distributed computing to **ensure privacy** for a wide and safe international **collaboration** as well as access to **diagnostic models in remote areas**
- **Competing technologies:**
  - No other technologies ready to use in the field, tailored to clinical needs and **privacy preserving**
- **Medical application:**
  - Brain pathologies detection, analysis and segmentation based on CNN applied to MRI images



# Final Output- Screening Tool





# MARCHESE: Remote Monitoring of Health Parameters

Background: response time of a rescue team of CERN Fire Brigade could take up to 22 minutes in the LHC tunnel.

The research is oriented towards the development of robotic solutions: workers' detection and health contactless monitoring during emergencies situations is important to support in search and rescue scenarios.

## PHOTOPLETHYSMOGRAPHY

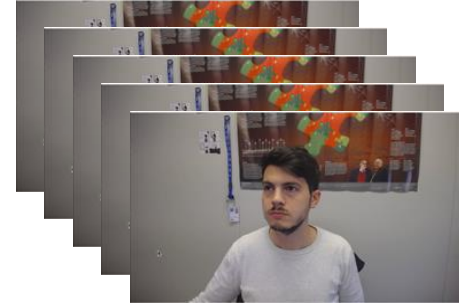
- Optical technique used to detect volumetric changes in the blood in the peripheral circulation.
- Blood volume changes in microvascular tissue (i.e. at cheeks and forehead level)



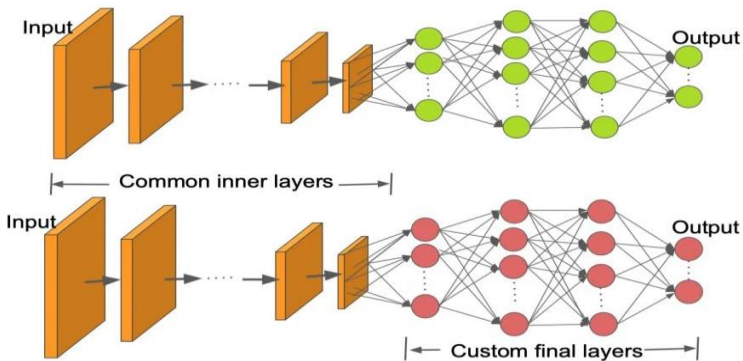
# Remote PPG: Video pre-processing



**30 FPS**  
 30 images/second  
 Logitech 1080p FULL HD  
 GPU NVIDIA GTX 1080p



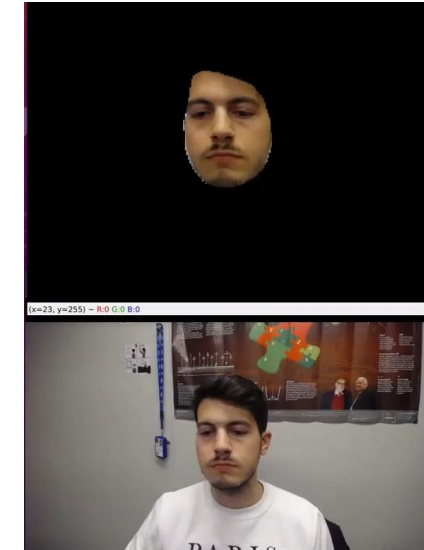
## NEURAL NETWORK



## SEPARATION of SKIN PIXELS from NO-SKIN PIXELS



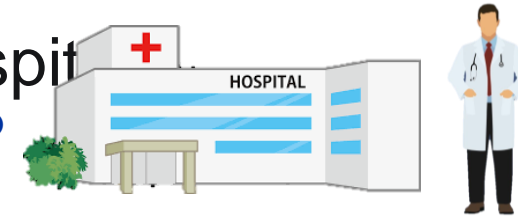
## REAL TIME



# Medical Applications

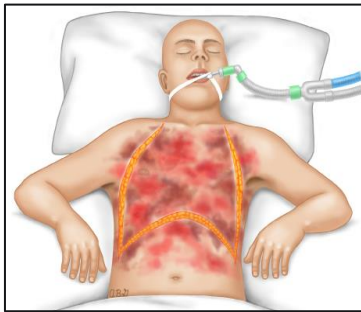
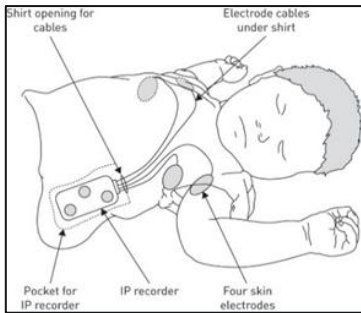
In contact with Medical Staff in the Hospital

- ➔ Understand which are the needs of the real scenario
- ➔ Develop technologies useful



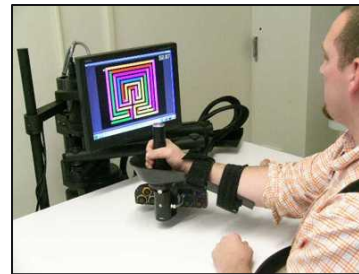
## NEWBORN and PATIENTS WITH BURNS

- Fragile skin
- No abrasions and damage of epidermis
- Continuous and constant monitoring



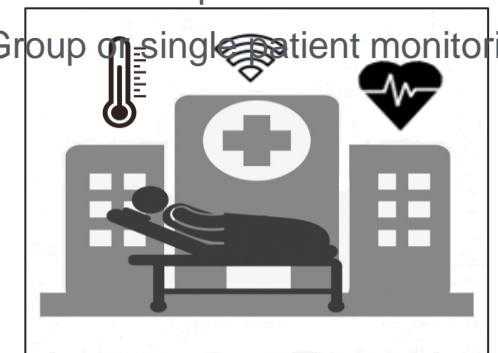
## ASSISTIVE ROBOTIC REHABILITATION

- adjust the exercise level (increase or decrease) according to the patient's physiological response
- Exploit residual patient capabilities (assistance-as-needed)

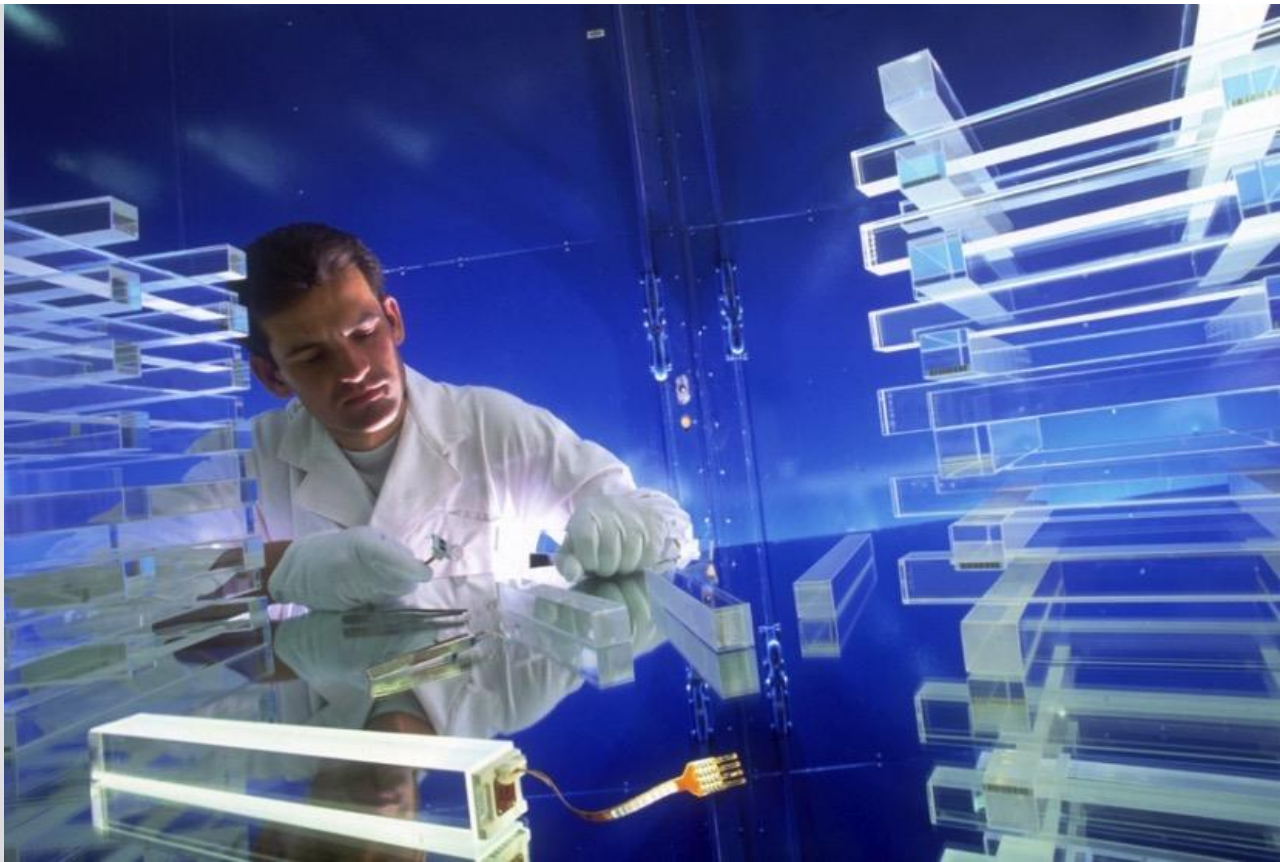


## SMART HOSPITAL ROOM

- Hospital room for remote monitoring
  - Avoid medical staff infections
- Hospitalization more comfortable for patients
- Group or single patient monitoring



# From HEP to society: a long and winding road...



# The Usefulness of Useless Knowledge

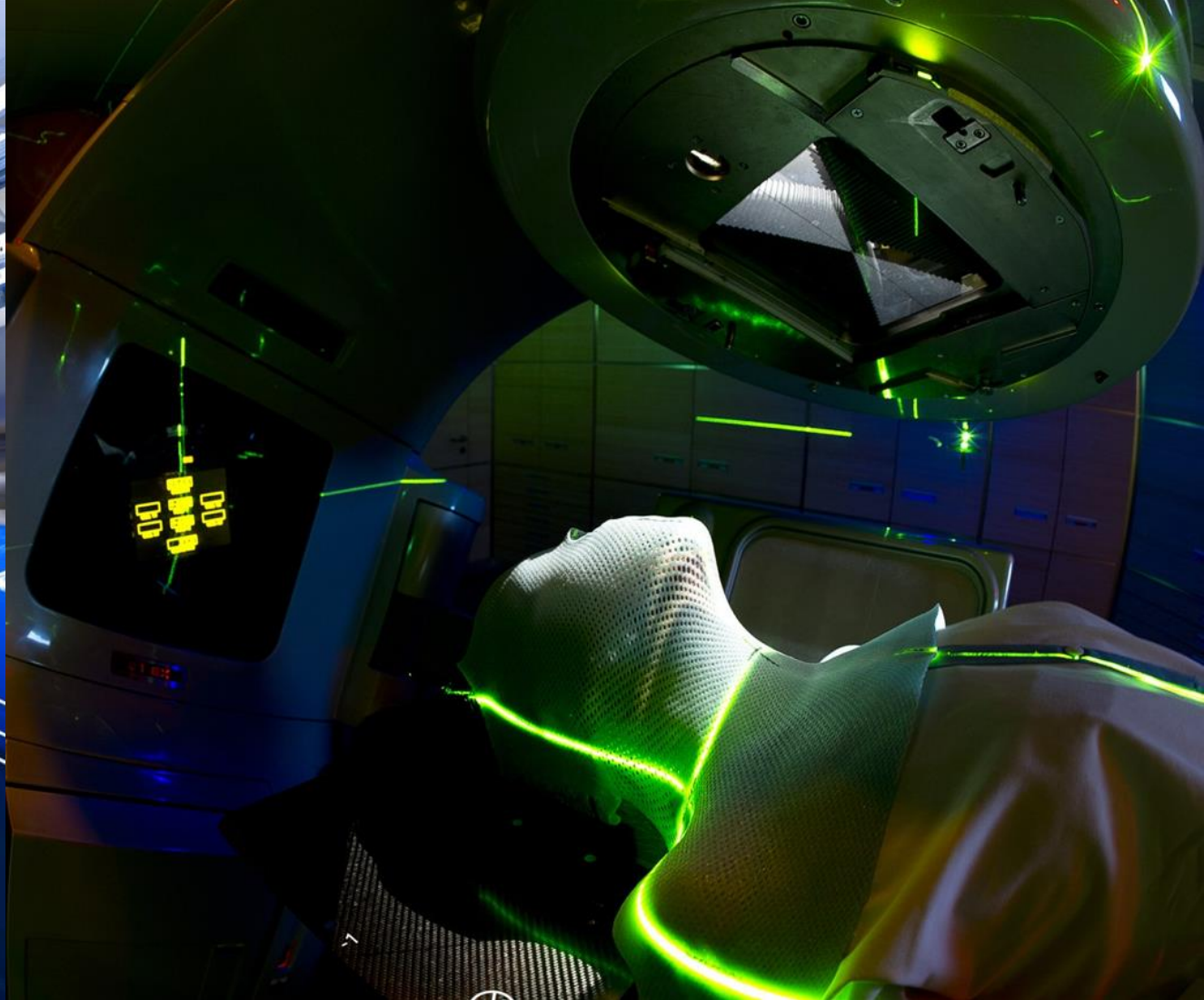
ABRAHAM FLEXNER

*With a companion essay by*  
ROBBERT DIJKGRAAF

1939!

In the end, utility resulted, but it was never a criterion to which his (*Faraday's, ndr*) ceaseless experimentation could be subjected.

I am not for a moment suggesting that everything that goes on in laboratories will ultimately turn to some unexpected practical use or that an ultimate practical use is its actual justification.



Knowledge Transfer  
*Accelerating Innovation*

Visit [kt.cern](https://kt.cern)