

Accident at TEPCO's Fukushima-Daiichi NPP



Akira OMOTO

**Professor, Tokyo Institute of Technology, and
Commissioner, Atomic Energy Commission**

*[Note] The views expressed in these slides do not represent the
consensus official view of AEC nor Titech*

Outline

✓ *What happened?*

What went wrong and what lessons?

Which learning's are universal?

Source area of 3.11 earthquake (multi-segment rupture)

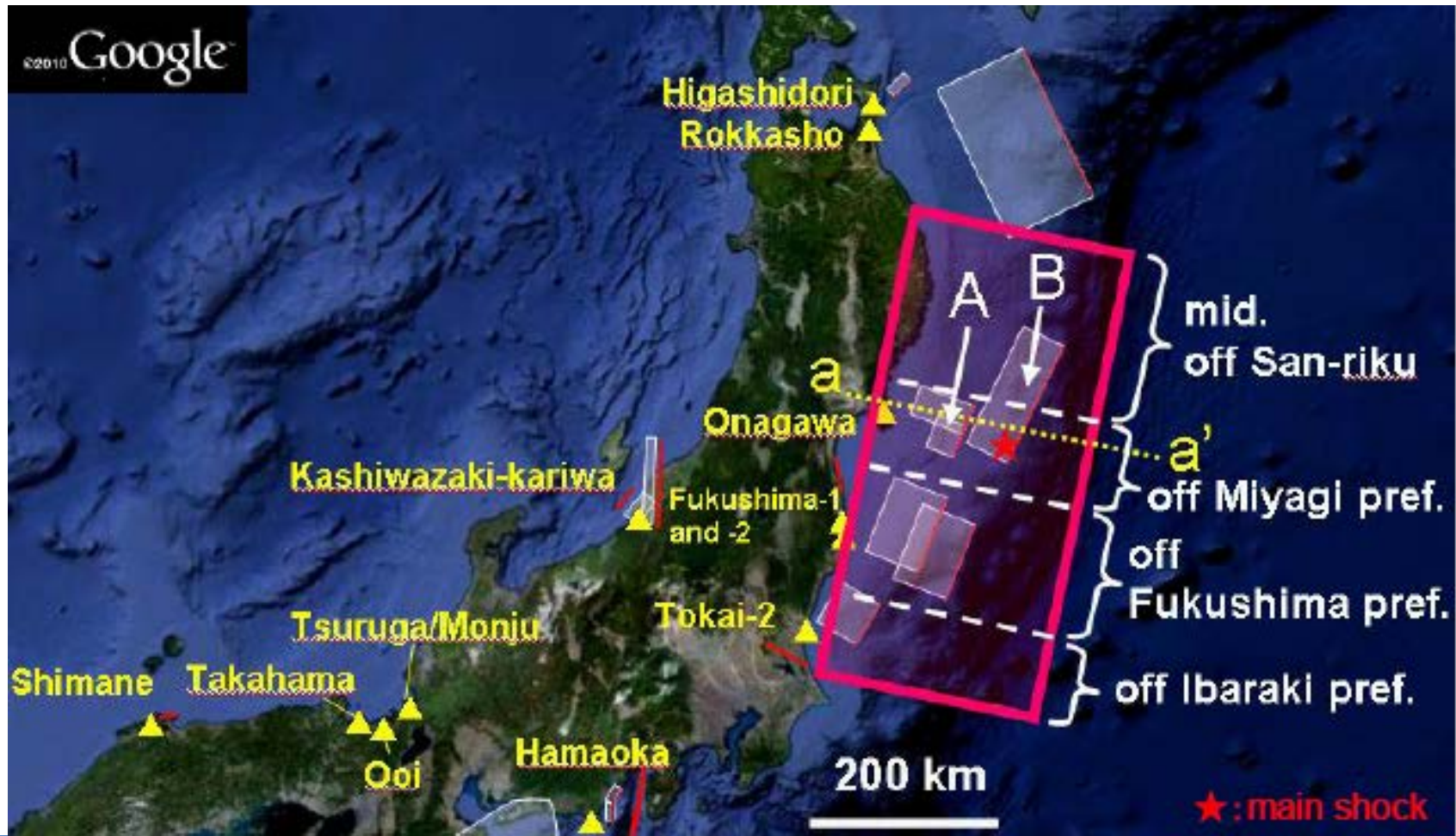

✓ Magnitude 9

✓ 200km x 500km (Initiated from B, extended to A and South)

✓ Statement by the Headquarter for Earthquake Research, 11 March 2011

occurrence of the earthquake that is linked to all of these regions is "out of hypothesis".

[SOURCE] <http://www.jishin.go.jp/main/index-e.html> The 2011 off the Pacific Coast of Tohoku Earthquake

Plant response

3.11 PM Earthquake and Tsunami left the plant under
Loss of power (AC/DC), Isolation from Heat Sink

Short term

automatic response

- Decay heat removal by AC-independent systems

Long term

Accident Management

- Depressurize reactor system
- Activate Low Pressure water injection systems

Not successful

Failure of AC-independent systems on the 3rd and 4th day
Core melt, hydrogen generation and explosion

Power supply for Unit 1-4

Offsite power: inoperable after Earthquake

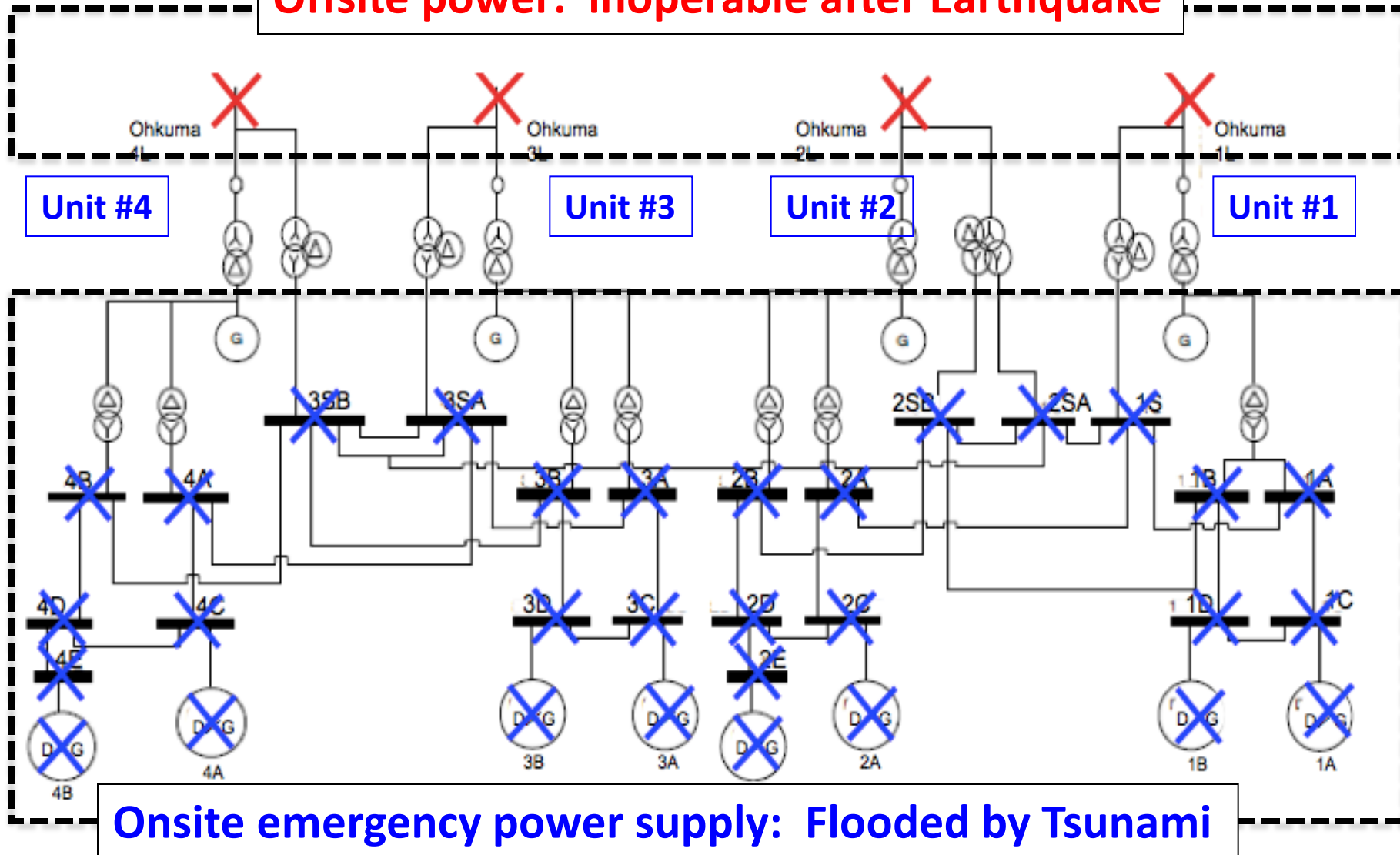

Reactor water makeup systems after Earthquake & Tsunami

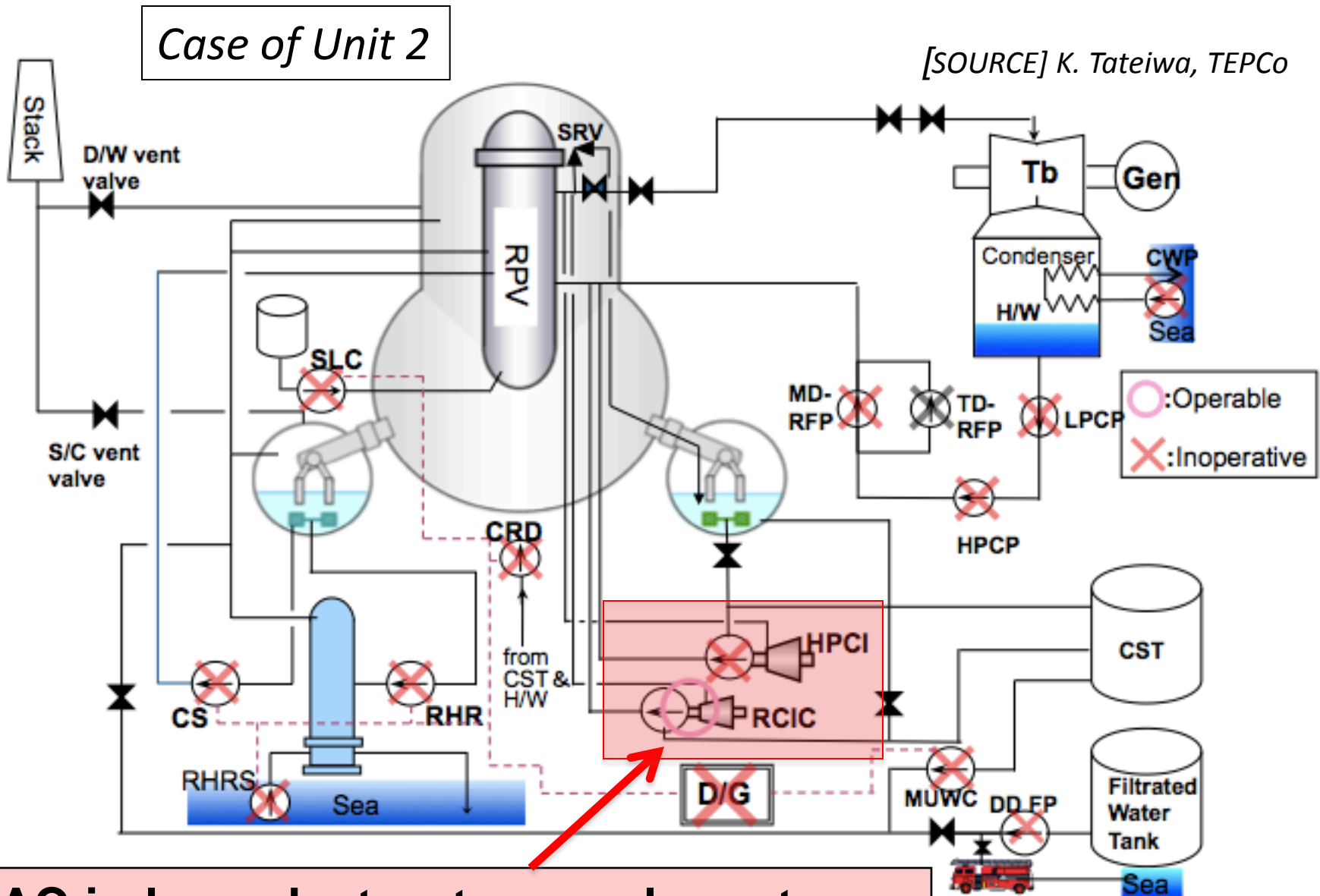

AC-independent water supply systems

Limited available resources under harsh environment

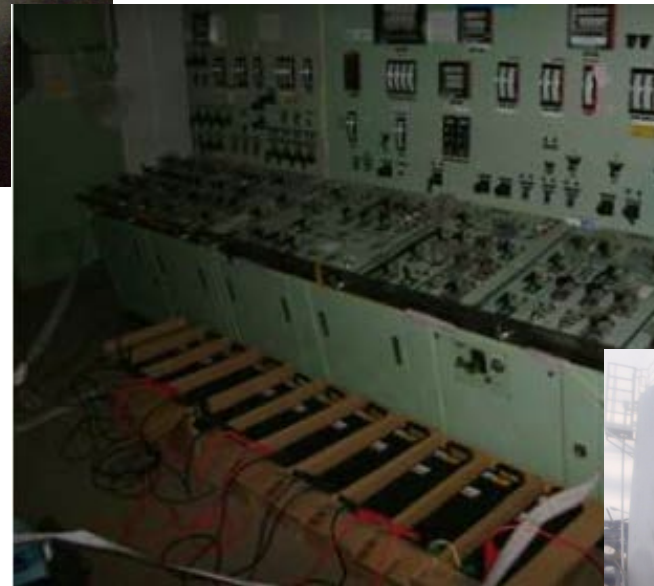
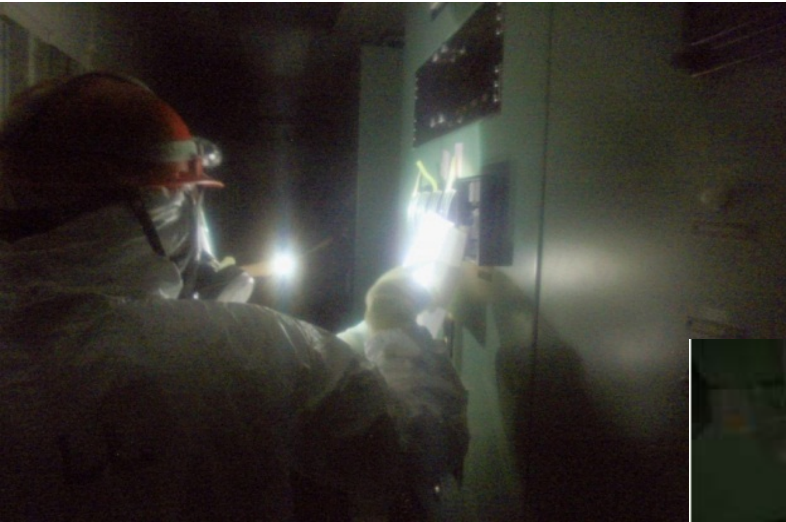

Consequences

Emergency plan

- Evacuation of 146,520 residents (evacuation mostly on 2nd-4th day)
- Food control since 8th day

Health effect

- No direct casualty
 - ✓ 60 death among evacuees from hospitals
 - ✓ 20,000 casualties by earthquake/tsunami
- External exposure to evacuees 99.3% < 10mSv
- Thyroid exposure < 100mSv

Economic impact

- Estimated 60B\$ accident cost
- +
- 30B\$/year power replacement cost

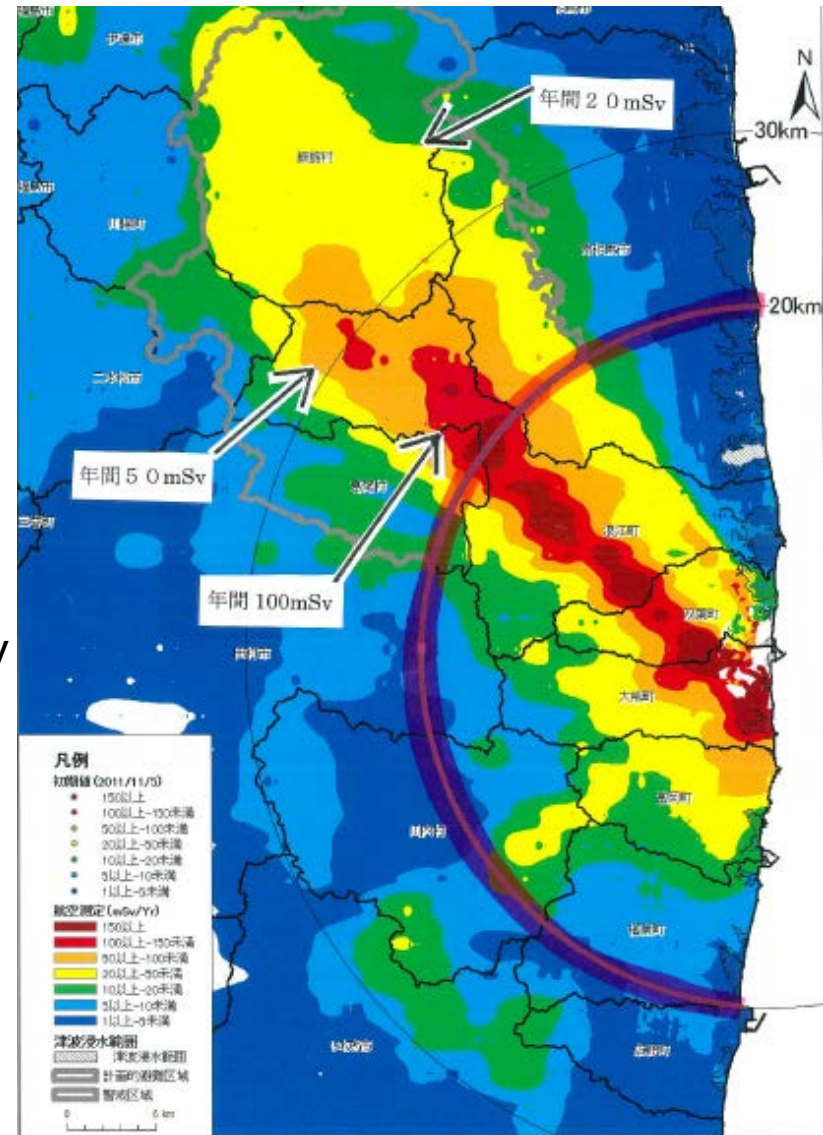

Predicted annual dose (as of 2011Nov5)
[SOURCE] http://www.meti.go.jp/earthquake/nuclear/pdf/111226_01a.pdf

Estimated release fraction to the environment

	Noble gas (Xe-133)	I-131	Cs-137
Half life	Very short	8 days	30 years
Unit 1	100%	0.9%	0.2%
Unit 2	65%	6%	2%
Unit 3	82%	0.3%	0.1%

Possibly linked

Land contamination In N-W region

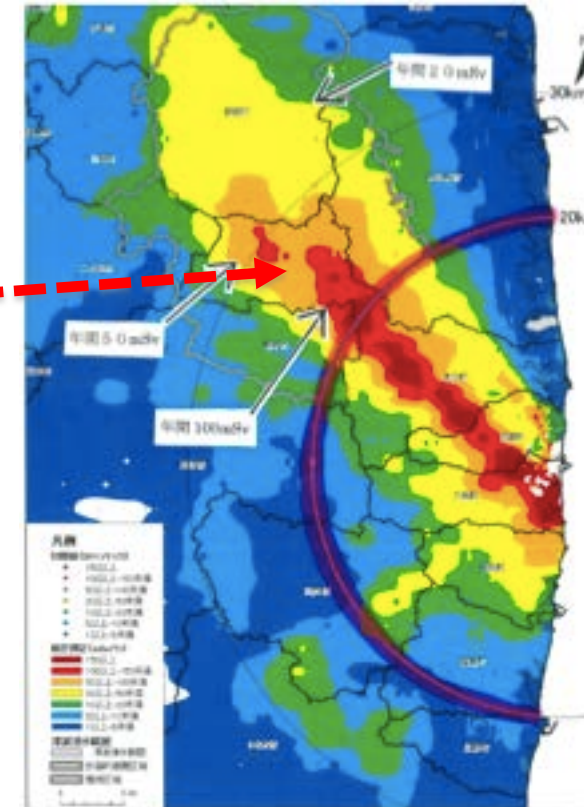

[SOURCE] <http://www.meti.go.jp/press/2011/10/20111020001/20111020001.pdf>

What happened?

✓ ***What went wrong and what lessons?***

Which learning's are universal?

Prevention of nuclear accident and Mitigation of radiological consequence from it

Defense in
Depth



*Level 5: Emergency Plan
(Evacuation)*

*Level 1-3: Prevention
by design*

*Level 4: Control of
beyond Design
Basis conditions*

*Level 1) Prevention of failure and
abnormal operation*

Level 2) Control of abnormal situation

Level 3) Control of accidents within design basis

Level-1 Prevention against failure

- **Conflicting views on earthquake at off-Fukushima coast**
 - ✓ “Tsunami earthquake can occur anywhere along Japan trench”
or
 - ✓ “weak coupling of plates and continuous slip in this region”
explains historically limited Tsunami record
- **TEPCO’S Tsunami study (2006, 2008)**
 - 2006 study: Less than 10(-5)/year as probability of exceeding 10m inundation height
 - 2008 study: hypothetically assuming M8.3 “off-Sanriku” (North of J trench) earthquake source at off-Fukushima coast → 15.7m inundation height
 - TEPCO had asked experts review

Technical lesson

Modifications based on flooding analysis by thinking “what happens if the assumed design condition is exceeded ?” could have changed the whole story

Level-4 Control of accident beyond design basis

Accident Management (AM) was prepared after Chernobyl, but not assuming damages caused by external /security events

damages

System, Structure, Components

Offsite power

Heat Sink

Communication system

Team

Technical lesson

- Accident Management was not robust enough
- Level 4 Defense-in-depth was damaged by the common cause (Tsunami) as damaged level 3 Defense-in-depth (design safety systems)

Level-5 Emergency plan and crisis management

- **Overall offsite actions (evacuation and food control) reduced health risks**

- **Identified problems**
 - ✓ Offsite center's function was lost
 - ✓ Confusion in implementation of EP (Notice to the public on evacuation, preparation of vehicles etc)
 - ✓ Delineation of responsibility including PM, communication among decision-makers

Technical lesson

Needs to revisit

- ✓ Delineation of responsibility, command line, coordination
- ✓ Design and function of "offsite center"
- ✓ Offsite emergency plan (scope of EPZ, workability)

Technical lessons

Key LL

- a) Design: protection against natural hazard, loss of all AC/DC power and isolation from Ultimate Heat Sink,
- b) Robustness of accident management,
- c) Preparedness against unexpected

Further

- Regulation (independence to enable safety-first decision making, technical competence)
- Multiple unit installation
- Accident instrumentation
- System interface and inter-dependence etc.

Lessons Learned from Post 3.11 situation

No production without trust

- ✓ Only 2 of the 50 nuclear power plants in Japan are in operation as of August 2012
- ✓ 30B\$/year for replacement power
- ✓ Government policy to reduce dependency on nuclear

Global actions to enhance safety in the light of Fukushima

1. Design and Risk Management

- ✓ Enhanced **prevention** against natural disaster (level 1)
- ✓ Enhanced **coping capability to beyond design basis conditions** (level 4) by Accident Management and dedicated response team
- ✓ **Avoid environmental impact** by augmenting containment capability

2. Stress test to measure capability (deterministic approach)

3. Regulation

Japan: new law to establish new regulatory body by integrating safety/security/safeguard under MoE

4. IAEA action plan (Safety standards, dissemination of information...)

5. Enhanced cooperate peer review (WANO)

What happened?

What went wrong and what lessons?



Which learning's are universal?

LL from not only causal chain of event but from deliberation of possible underlying factors

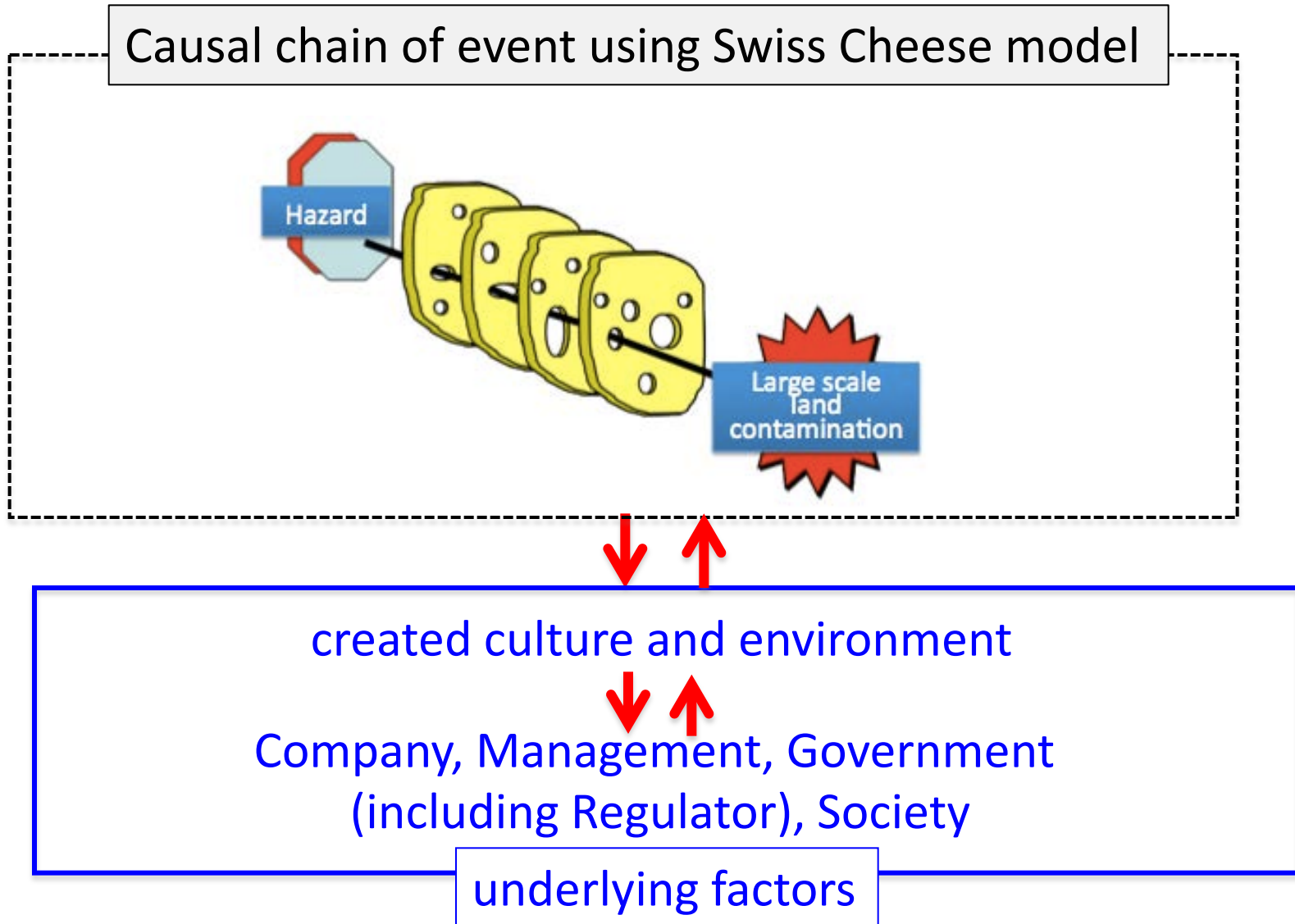

Possible underlying cultural factors

- 1) Questions that should have been raised before decision-making;
 - “Do we really know implicit assumptions in the analysis?”
 - “What if the assumed condition was wrong?”
 - “What are the global best practices?”
- 2) Assumptions in the most basic level of safety culture
 - ✓ “Accident will not happen here” (Emergency Plan, icanps report)
 - ✓ Over-confidence in safety by focusing on equipment reliability
- 3) Environment of “Government-endorsed-business”, and, [maybe resultant] lack of sense of responsibility as an individual (Operator/Regulator/Local government)

Diet (Congressional) Investigation Committee [NAIIC]

Report published, 5 July 2012

[source] http://naiic.go.jp/wp-content/uploads/2012/07/NAIIC_report_lo_res2.pdf

- “**Manmade**” disaster
- “A disaster **made in Japan.**”
*“Its fundamental causes are to be found in the ingrained conventions of **Japanese culture** (our reflexive obedience; our reluctance to question authority; our devotion to ‘sticking with the program’; our groupism; and our insularity)”*
- Highlighted
 - 1) “**Regulatory capture**” : regulatory body in a ministry to promote energy security and, due to lack of in-house expertise, relied on Utility in setting regulatory requirements
 - 2) Deficiency in crisis management system including meddling by PM on onsite operation

Report to the President from National Commission on Deepwater Horizon Oil Spill

- “Cross-purpose” MMS (Minerals Management Service)
 - ✓ **Promotion** of offshore drilling to reduce foreign energy supplies **and Regulation**
 - ✓ Lack of in-house expertise for regulation
- Standards by experts (API)
- BP’s mistake of exercising caution in decision-making
- Culture of complacency (Government, BP)
- Self-policing (INPO)
- Need for Marine Well Containment System

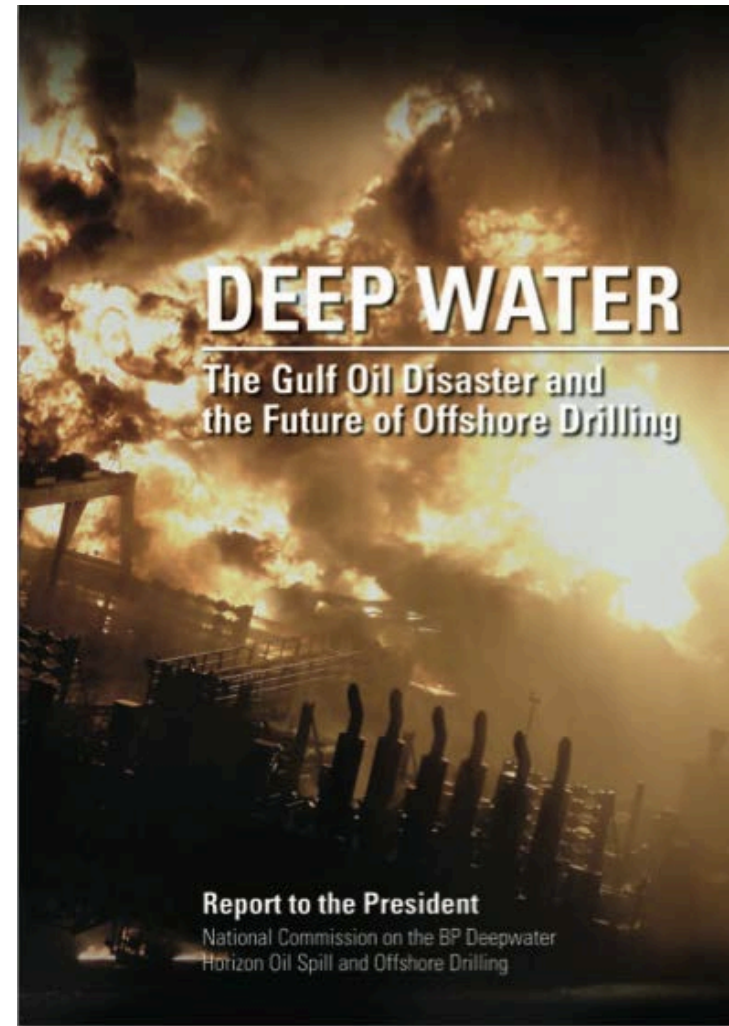

Government Investigation Committee [ICANPS]

Report published, 23July2012 [source] <http://icanps.go.jp/eng/>

- Preparedness to **combined disaster** by natural hazard and consequential nuclear accident
- TEPCO & Government trapped by “**safety myth**” by thinking “severe accident will not happen here”
- **Paradigm shift (expressed as “changing attitude”) in risk management** to avoid nuclear disaster
 - ✓ [Comprehensive] mitigation, regardless of its probability of occurrence

Paradigm shift in nuclear safety?

- Before TMI: Accident primarily attributed to component failures → **component reliability**
- TMI: Highlighted **human factors** (man-machine interface) and PSA
- Chernobyl: Highlighted **safety culture** and Accident Management (4th layer of defense-in-depth)
- **Fukushima: ?**

Universal learning's

1. Resilience

- ✓ Organization: Capability to Respond, Monitor, Anticipate, Learn in varying conditions to lead to success especially, **cautious attitude to anticipate prepared to unexpected**
- ✓ Design: Independence in each layer of Defense in Depth

2. Culture of Responsibility

- ✓ Operator: primarily responsible
- ✓ Regulator: Independence to protect public health and environment, with in-house expertise

3. “Social license to operate” (IAE, 2012May, “Golden rule for Golden age of Gas”)

- ✓ Managing LPHC risk
 - prevention & mitigation
 - avoid long-term environmental effect by all means
- ✓ Confidence building with the Society
- ✓ Liability system



Thank you for your attention