

MICE Integration Engineering

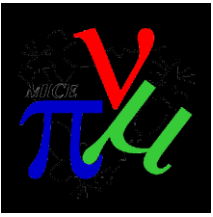

Jason Tarrant - STFC

- Contents
 - » Device Interfaces – General
 - » AFC
 - » Spectrometer Solenoids
 - » RFCC
 - » EMR / KL
 - » South Mezzanine (summary)

MICE Integration Engineering

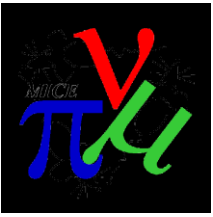

- AFC

- » Geometry

- Tesla support system modifications = suspension system turrets changed (model received 3/7/11)

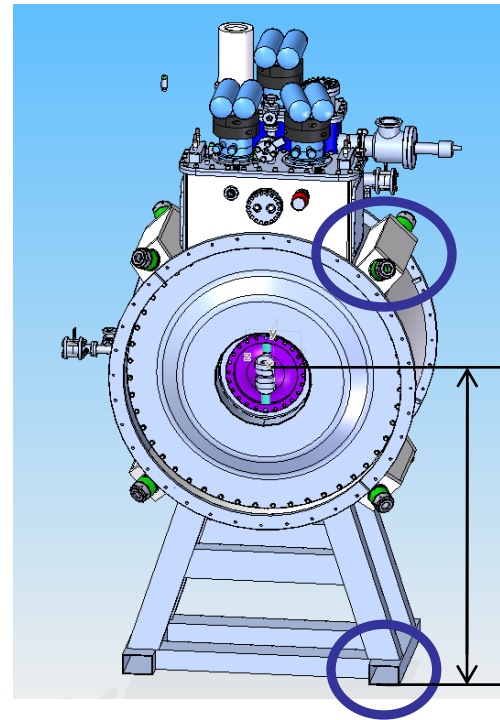
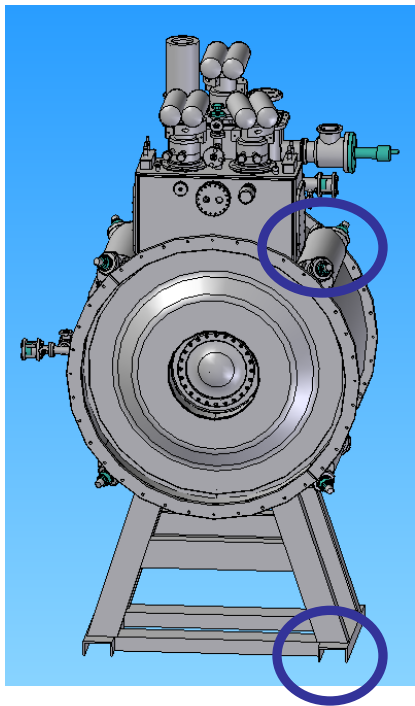

1534!
Asked to change
back to 1515

MICE Integration Engineering

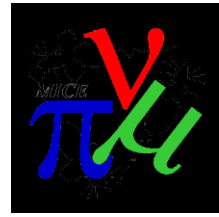

- AFC

- » Geometry

- Hydrogen Safety Vacuum Line clash with South Mezzanine

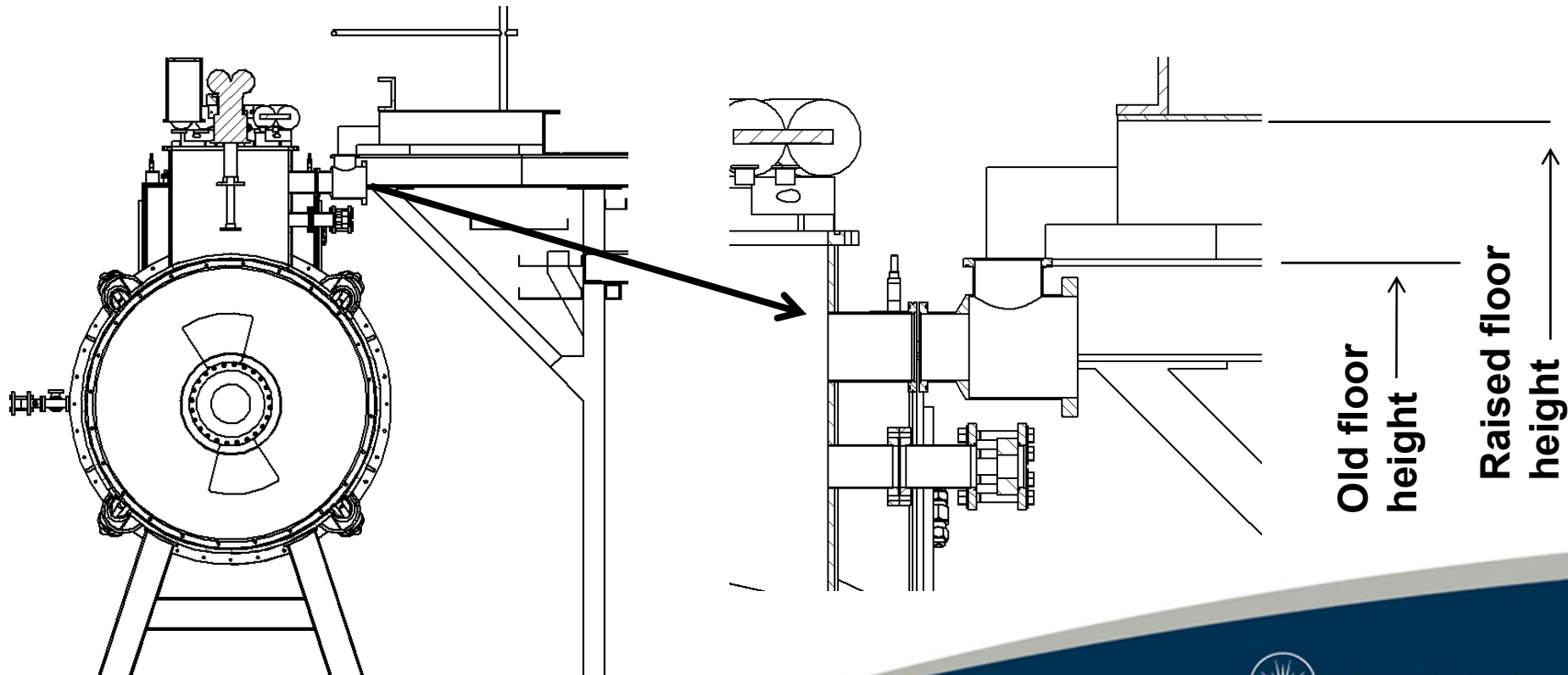

MICE Integration Engineering

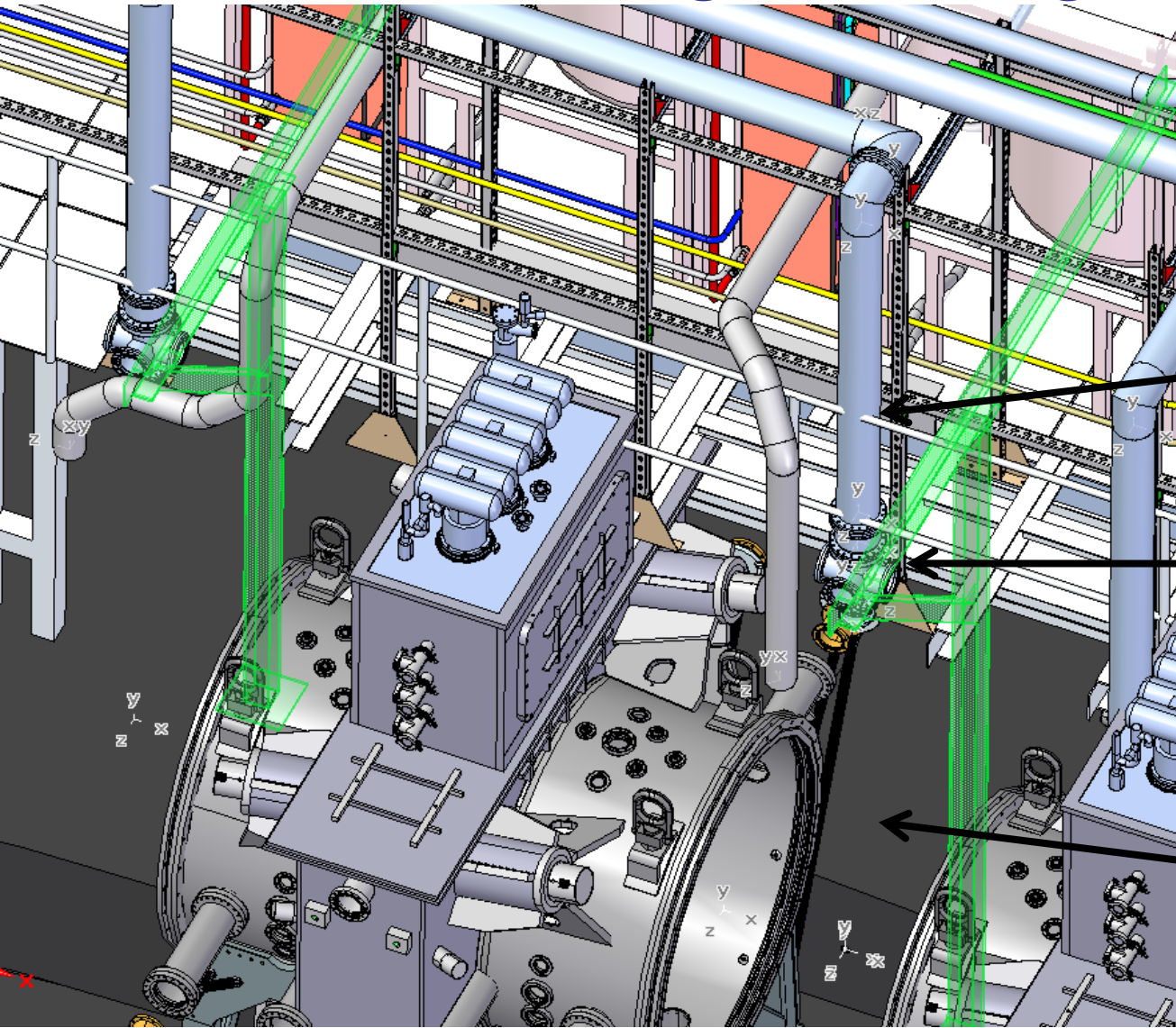
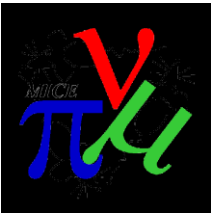

Clash with rails

Clash with support leg

AFCs not shown so vacuum pipe run can be seen

MICE Integration Engineering

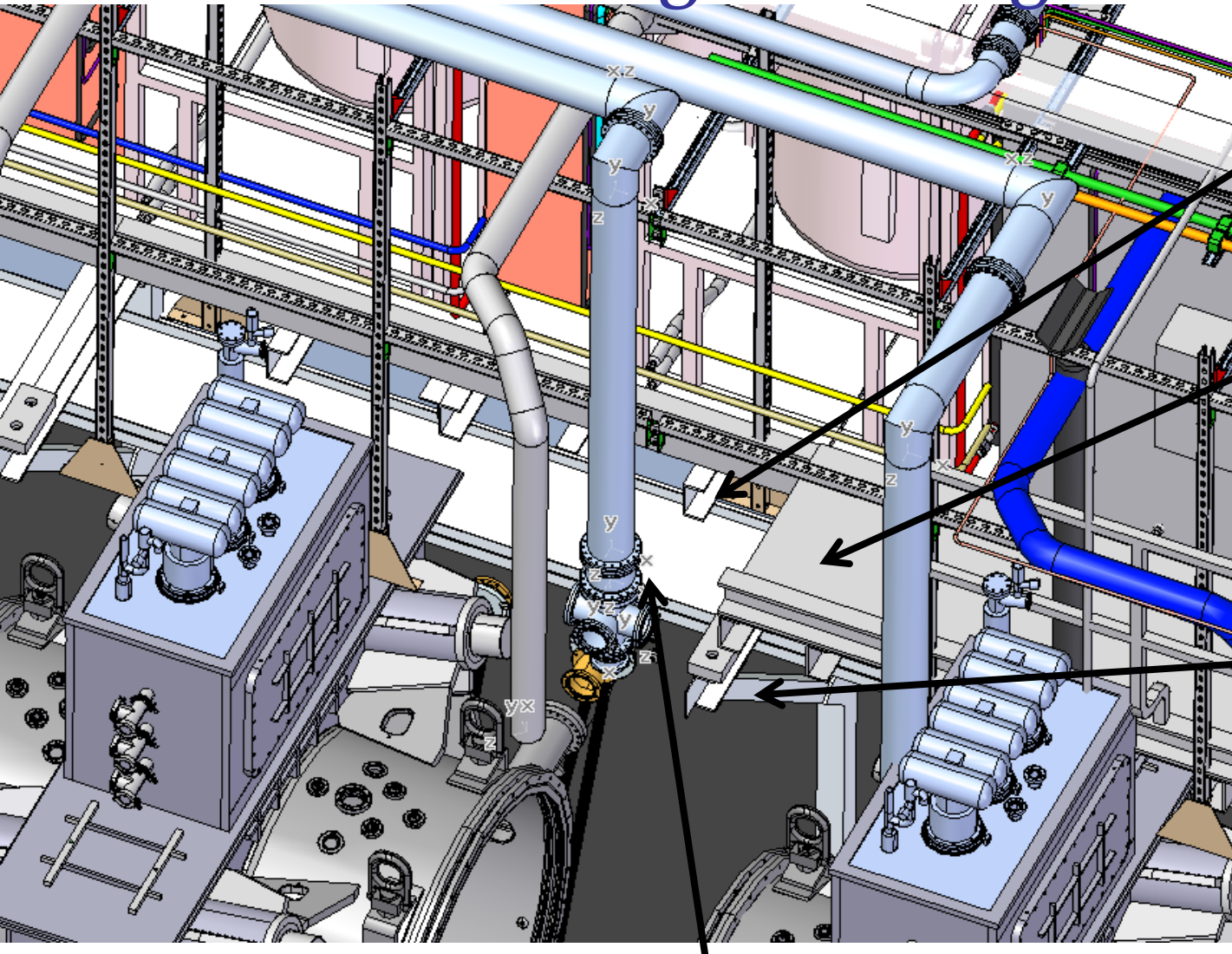
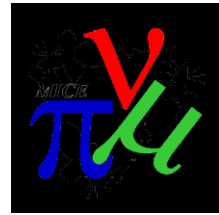

Beams cut back

Raised & narrowed floor section
(removable but H system parts temporarily moved)

Support leg moved to next beam

Cut required in floor panel around vacuum pipe

MICE Integration Engineering

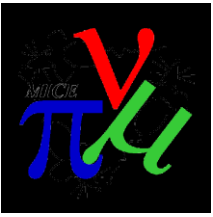

- Spectrometer Solenoid
 - » Interface with rolling platforms

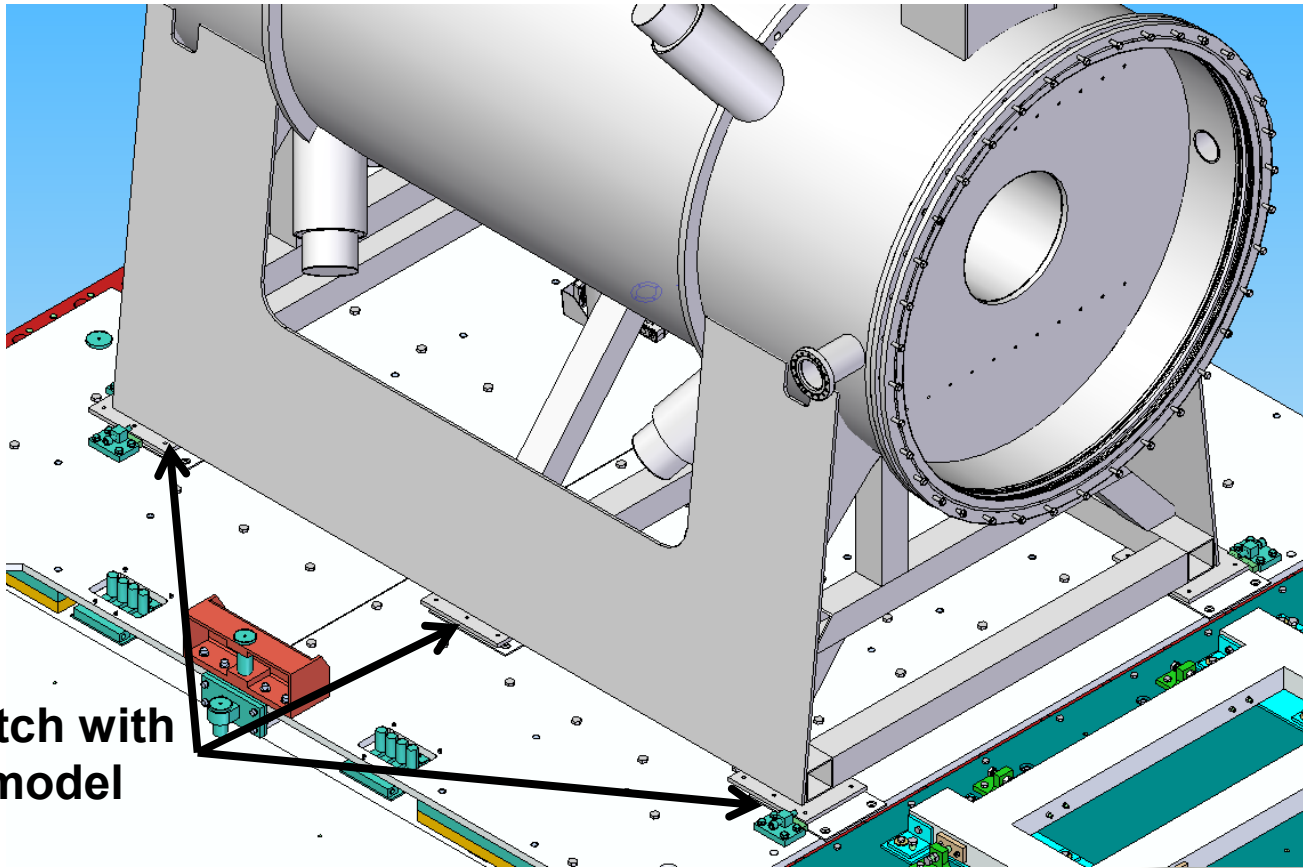

Mismatch with latest model

MICE Integration Engineering

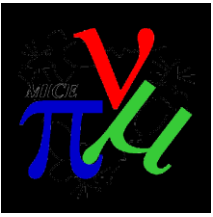

- Spectrometer Solenoid
 - » Interface with rolling platforms

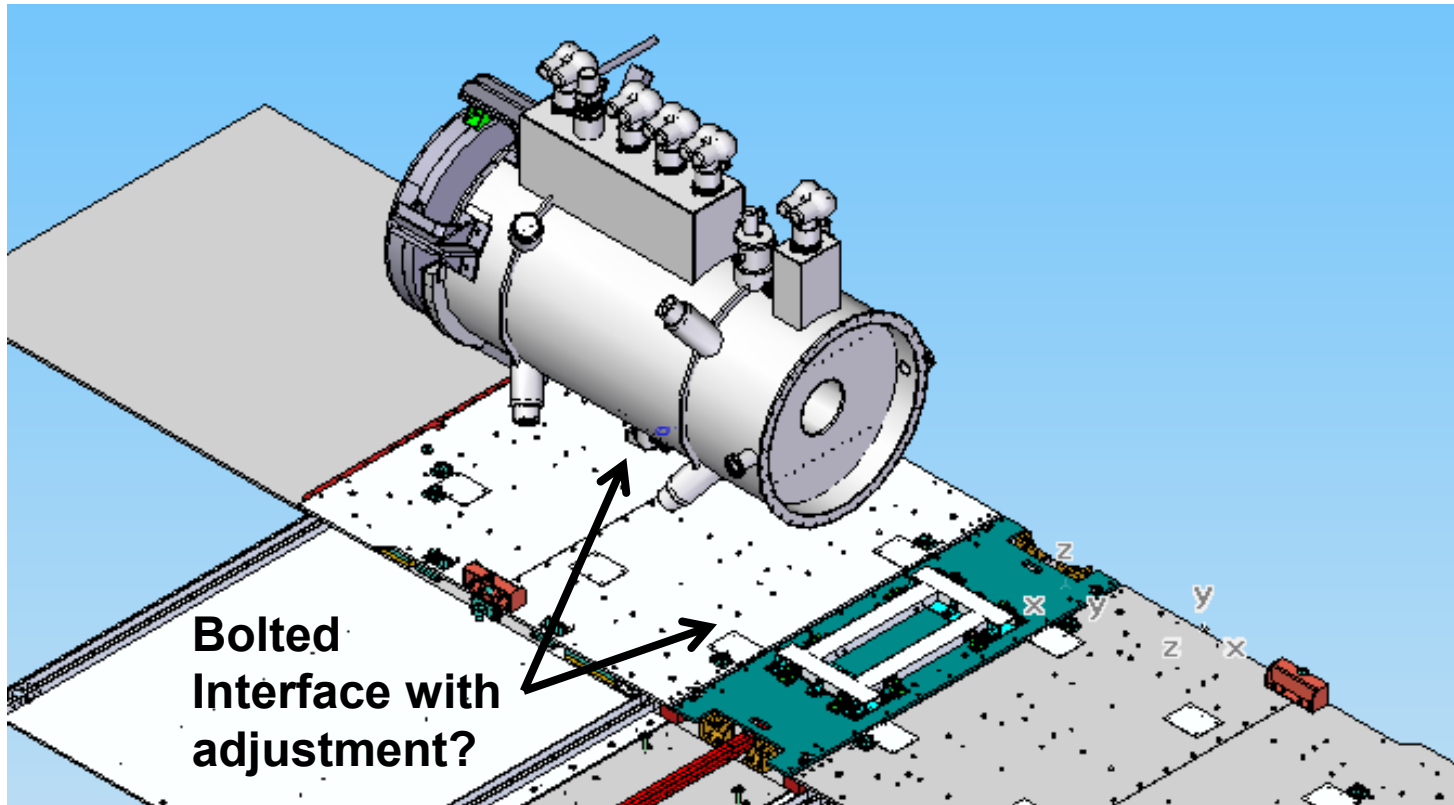

MICE Integration Engineering

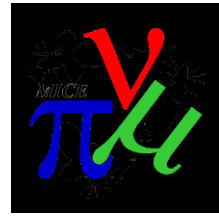

- Spectrometer Solenoid

- » Geometry

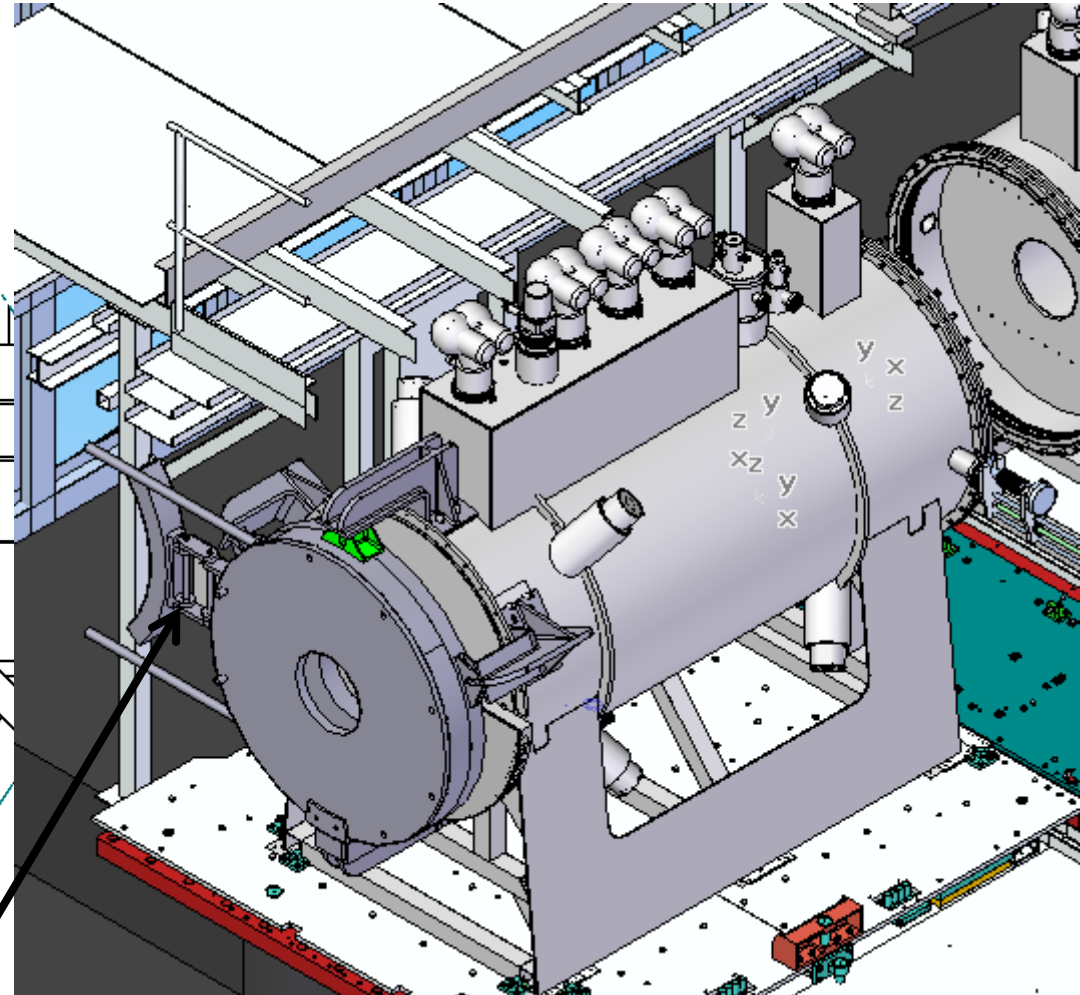
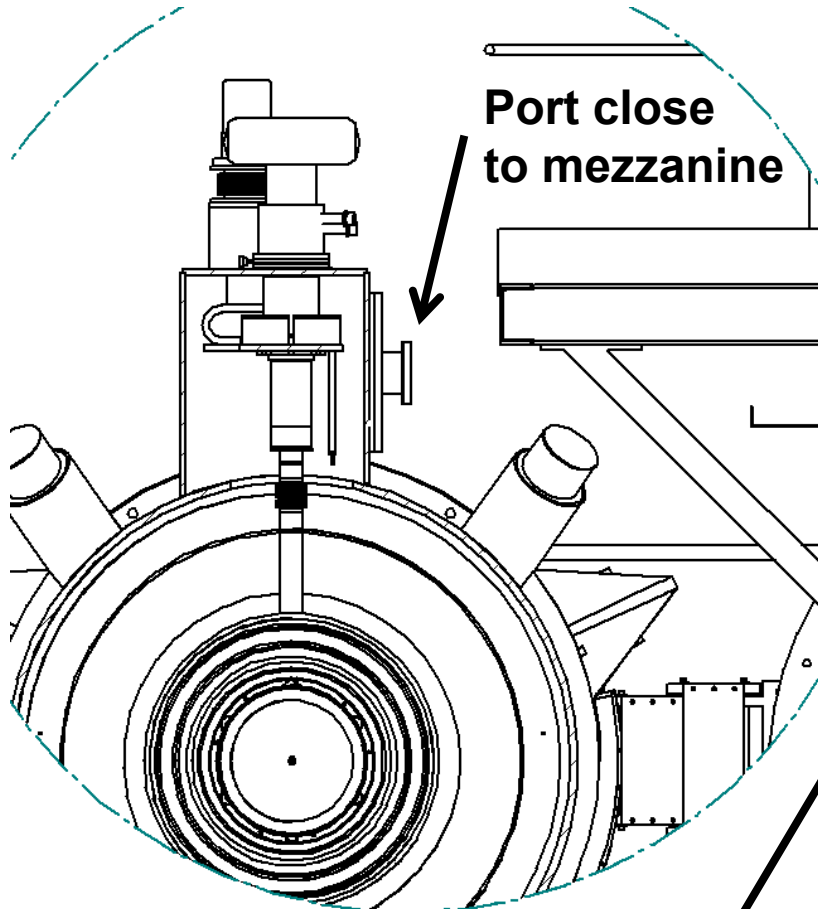

Rotate for convenience?

MICE Integration Engineering

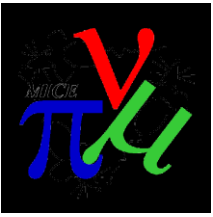

- Spectrometer Solenoid
 - » Geometry

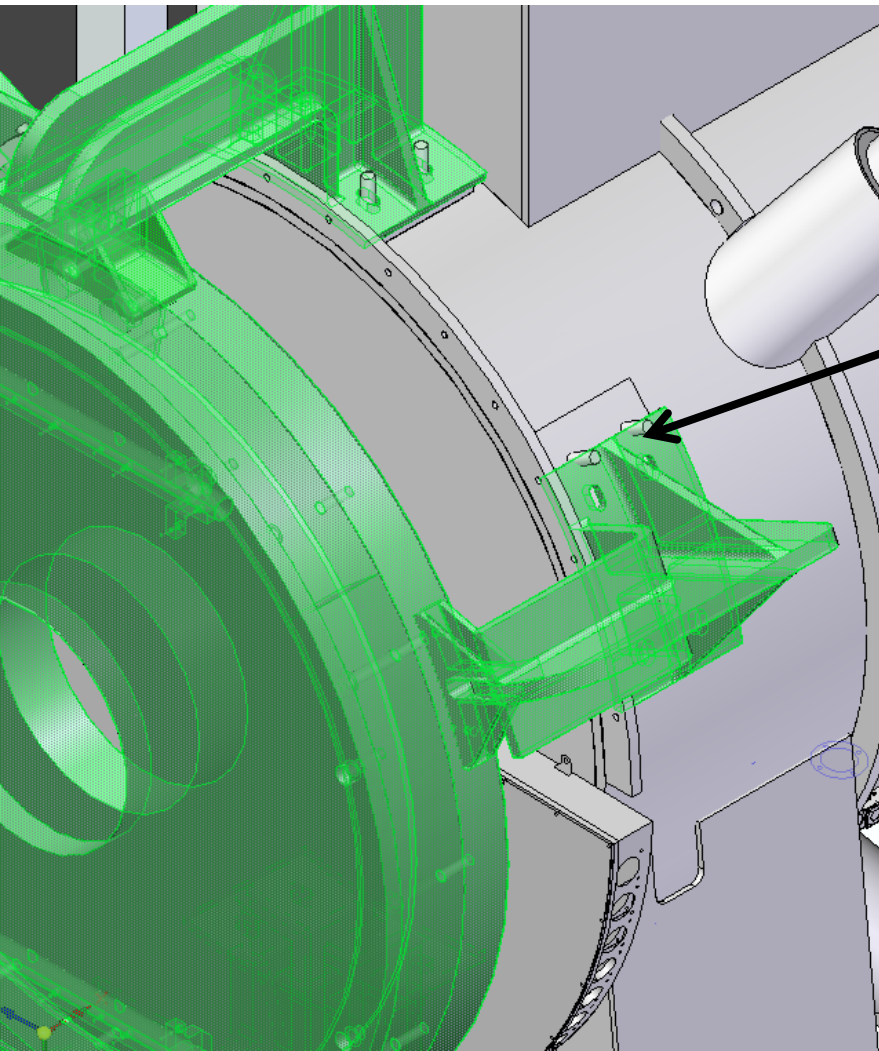

**Brackets not align
with latest model**

MICE Integration Engineering

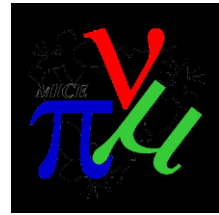

- RFCC

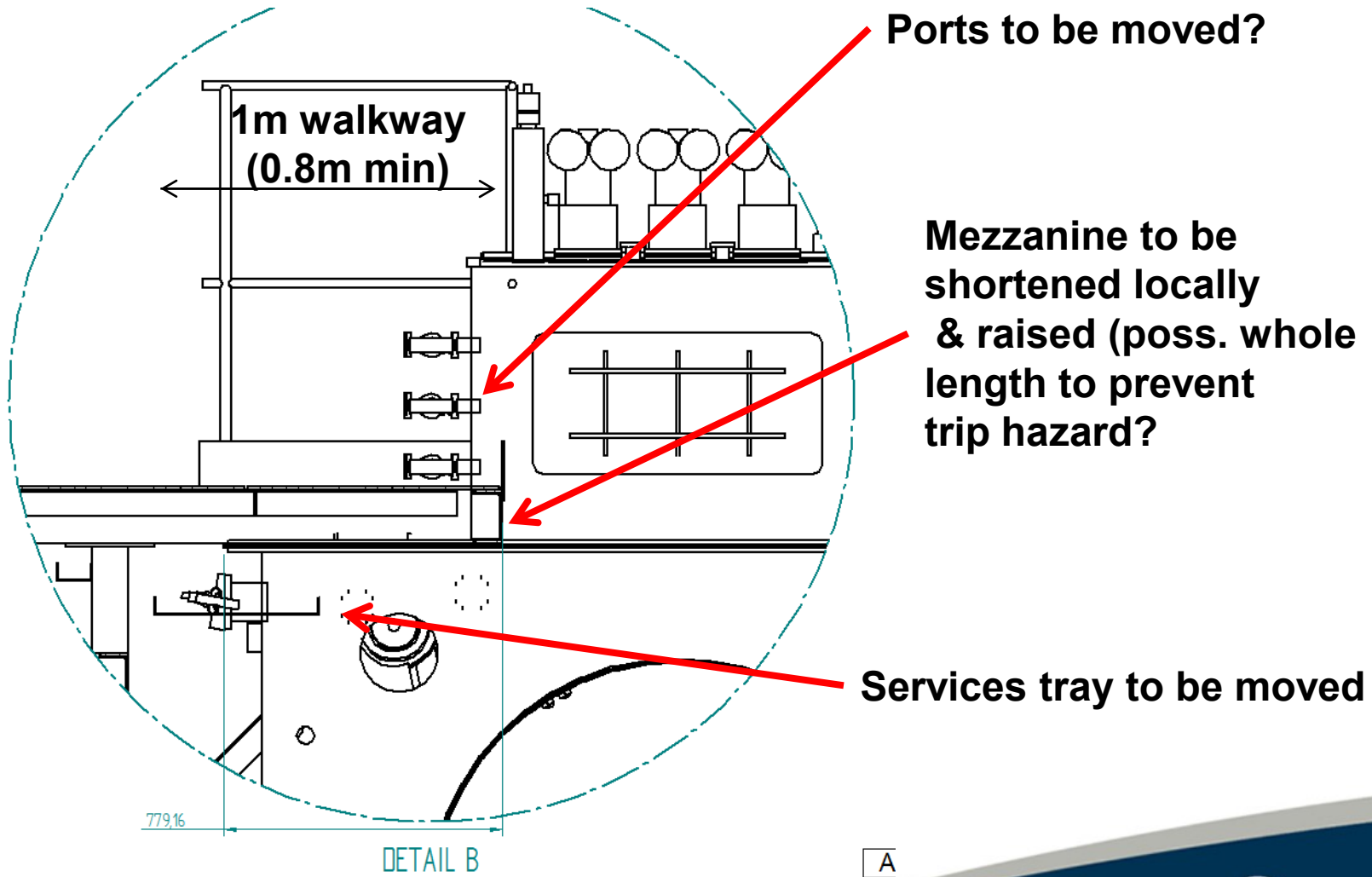

MICE Integration Engineering

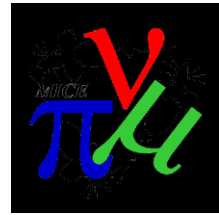

- RFCC

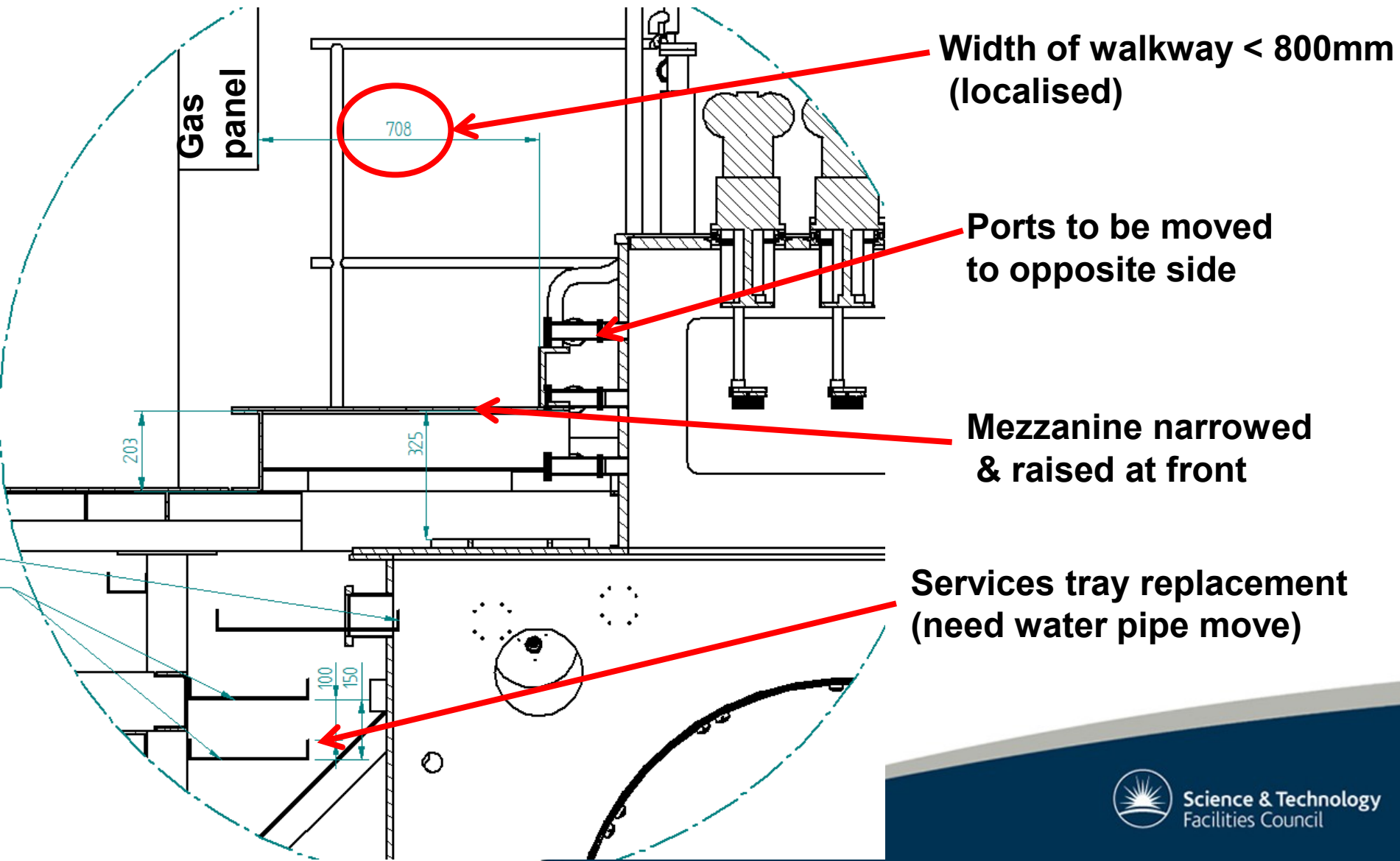

MICE Integration Engineering

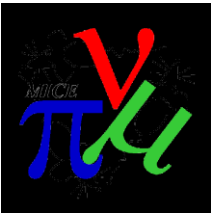

- RFCC

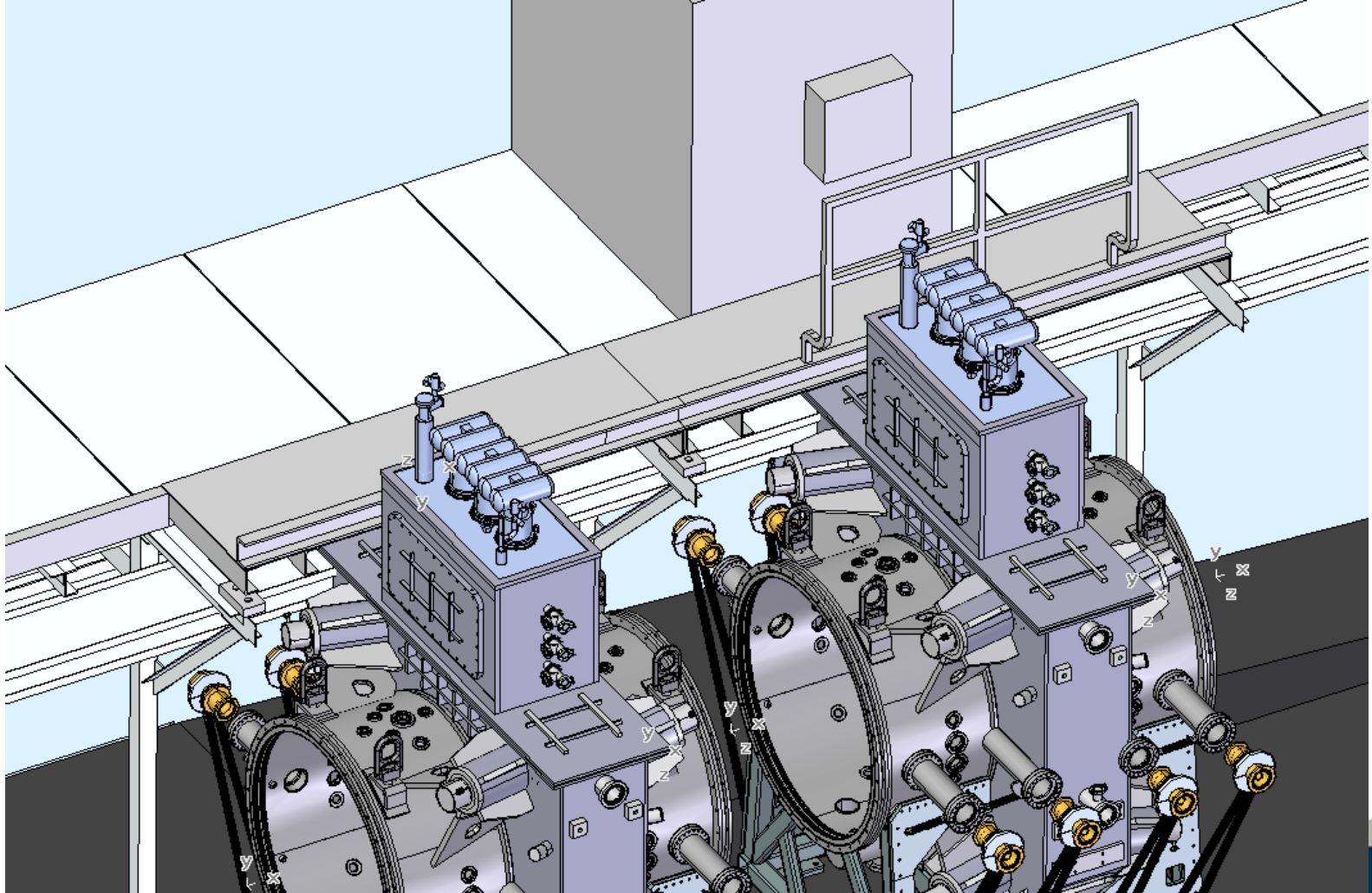

MICE Integration Engineering

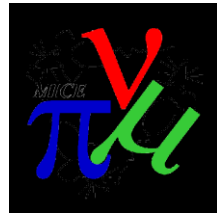

- EMR

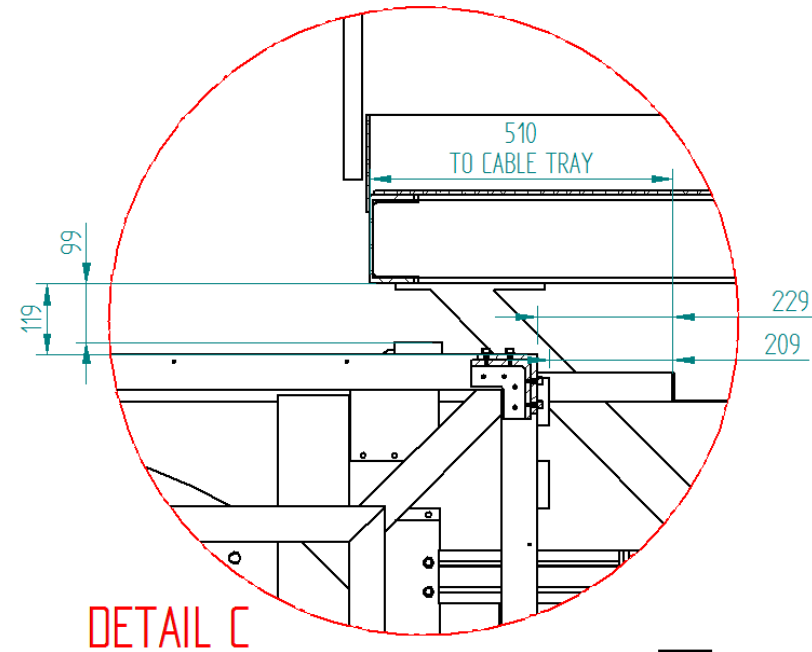
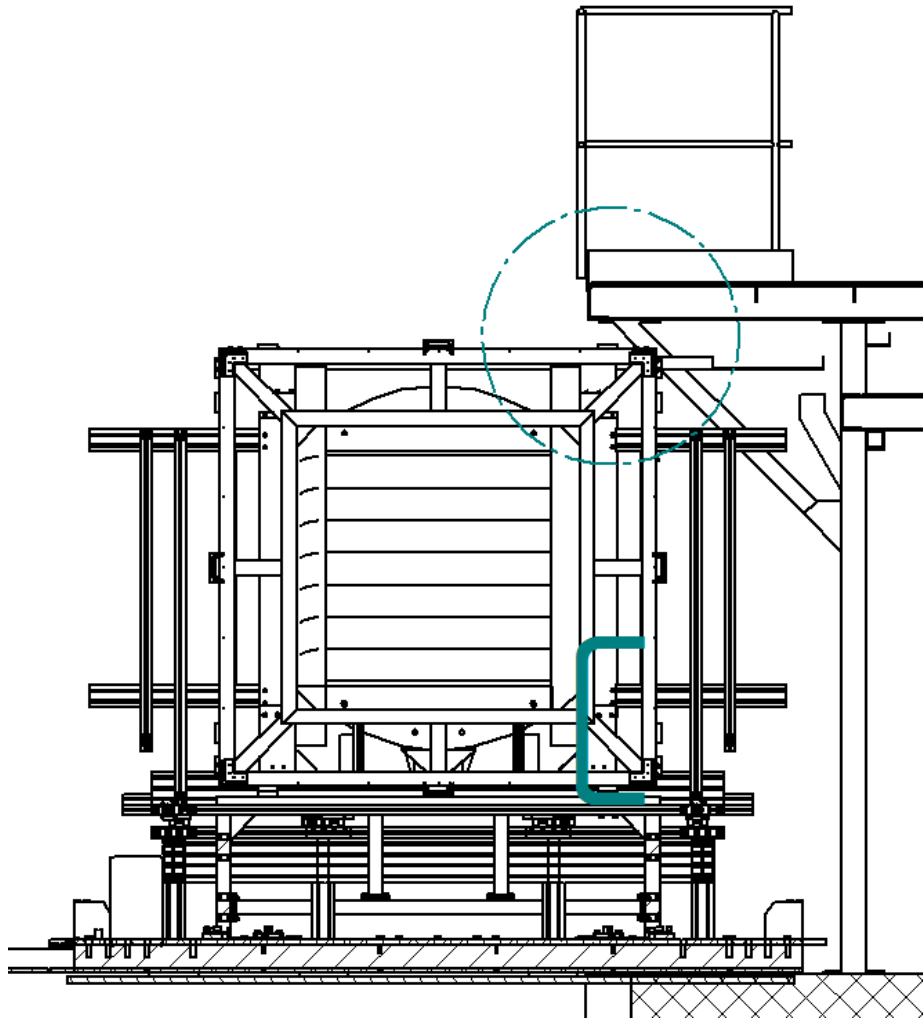

MICE Integration Engineering

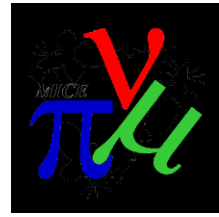

- Mezzanine & EMR

Floor plates removed

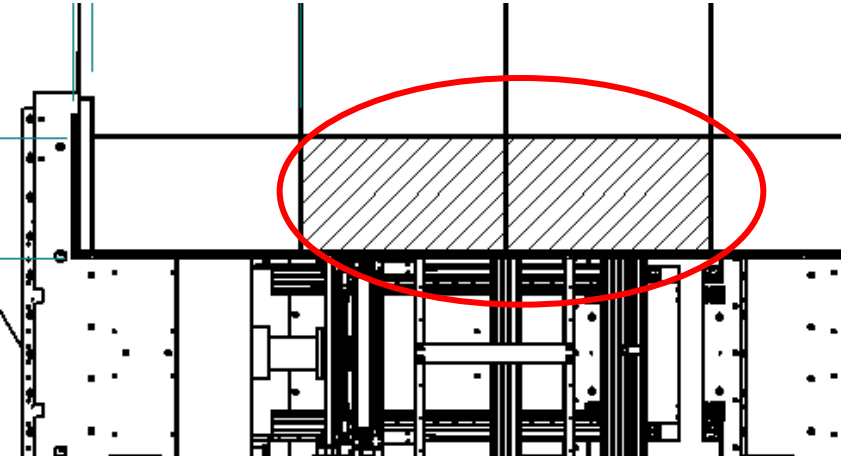

Beams cut back

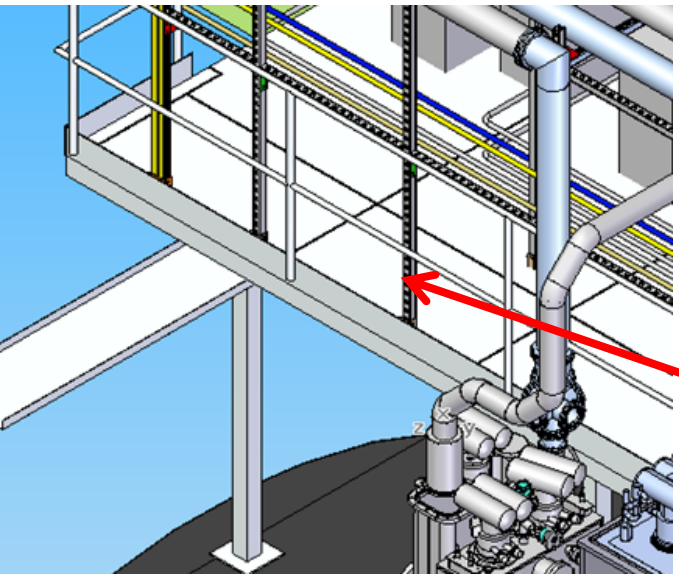
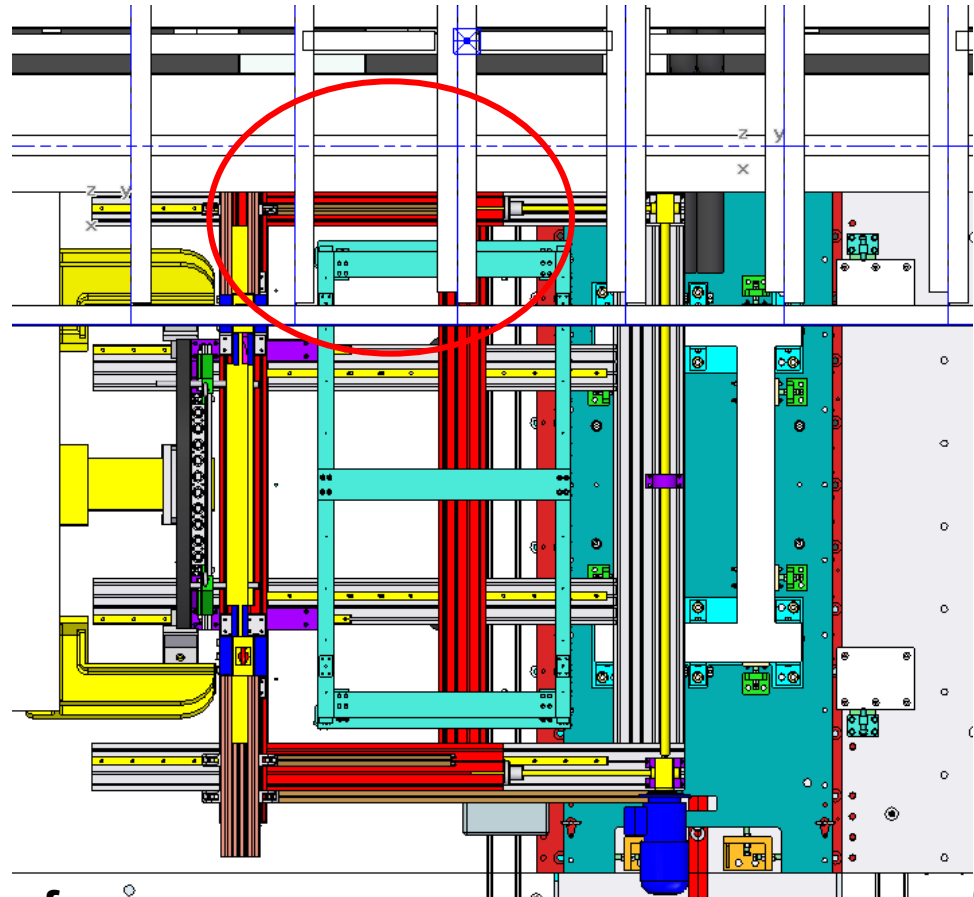

Hydrogen frame
clash (work postponed)

MICE Integration Engineering

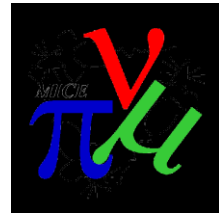

- Mezzanine & EMR

Potential clash
With support pillars

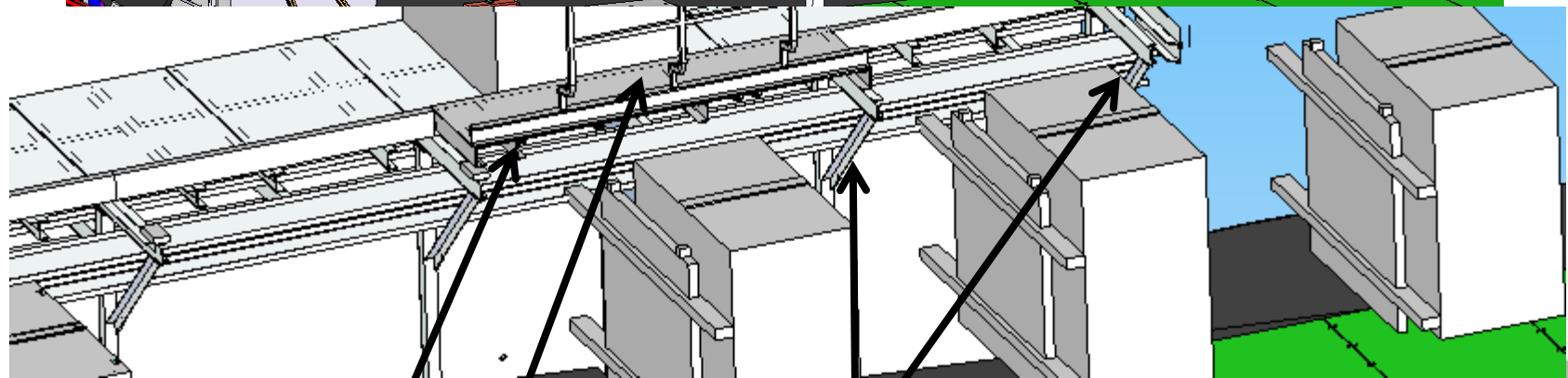
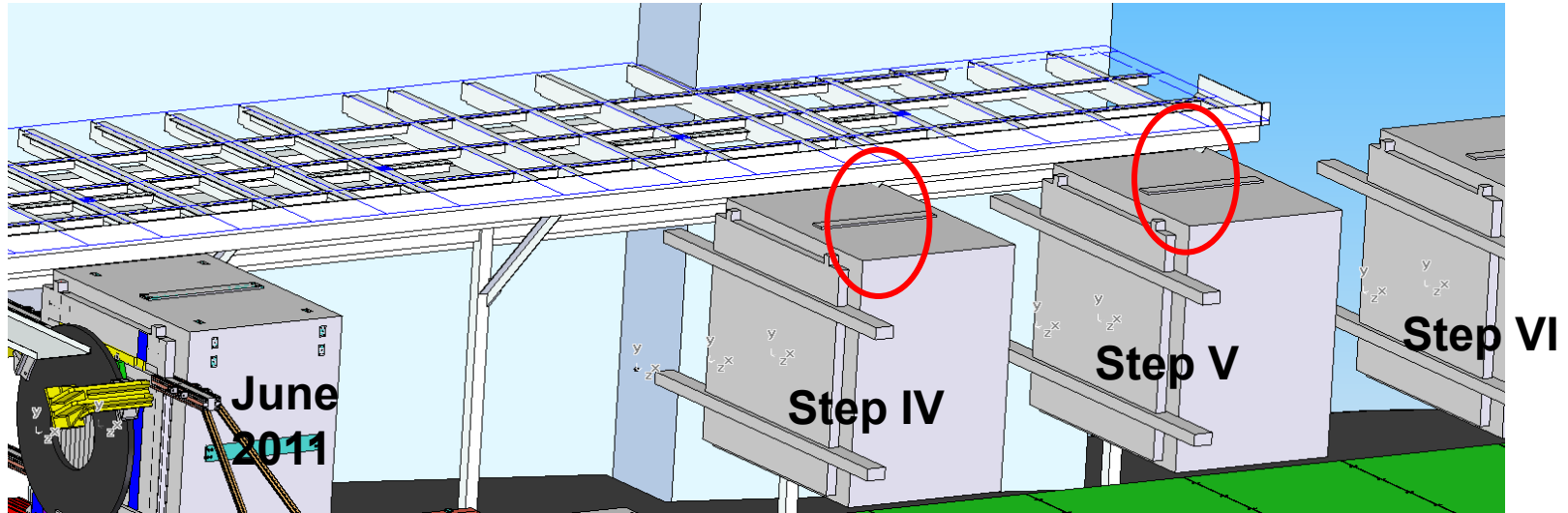

Beams cut back

Removable
floor section

Support
legs moved



MICE Integration Engineering

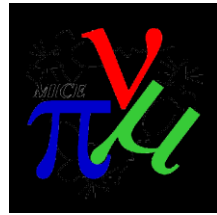

- South Mezzanine change summary
 - » Move 4 of 5 support legs to another beam
 - » Fit cross beam between support legs to support intermediate beams before cutting intermediates
 - » Fit removable platform sections spanning between support leg beams
 - Higher & narrower than current mezzanine (avoids RFCC & AFC pipe line)
 - Outer beam = kick plate
 - Rail with dog leg fitted to outer beam

MICE Integration Engineering

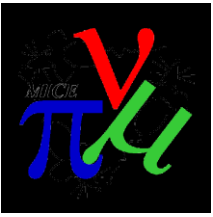

- South Mezzanine change summary

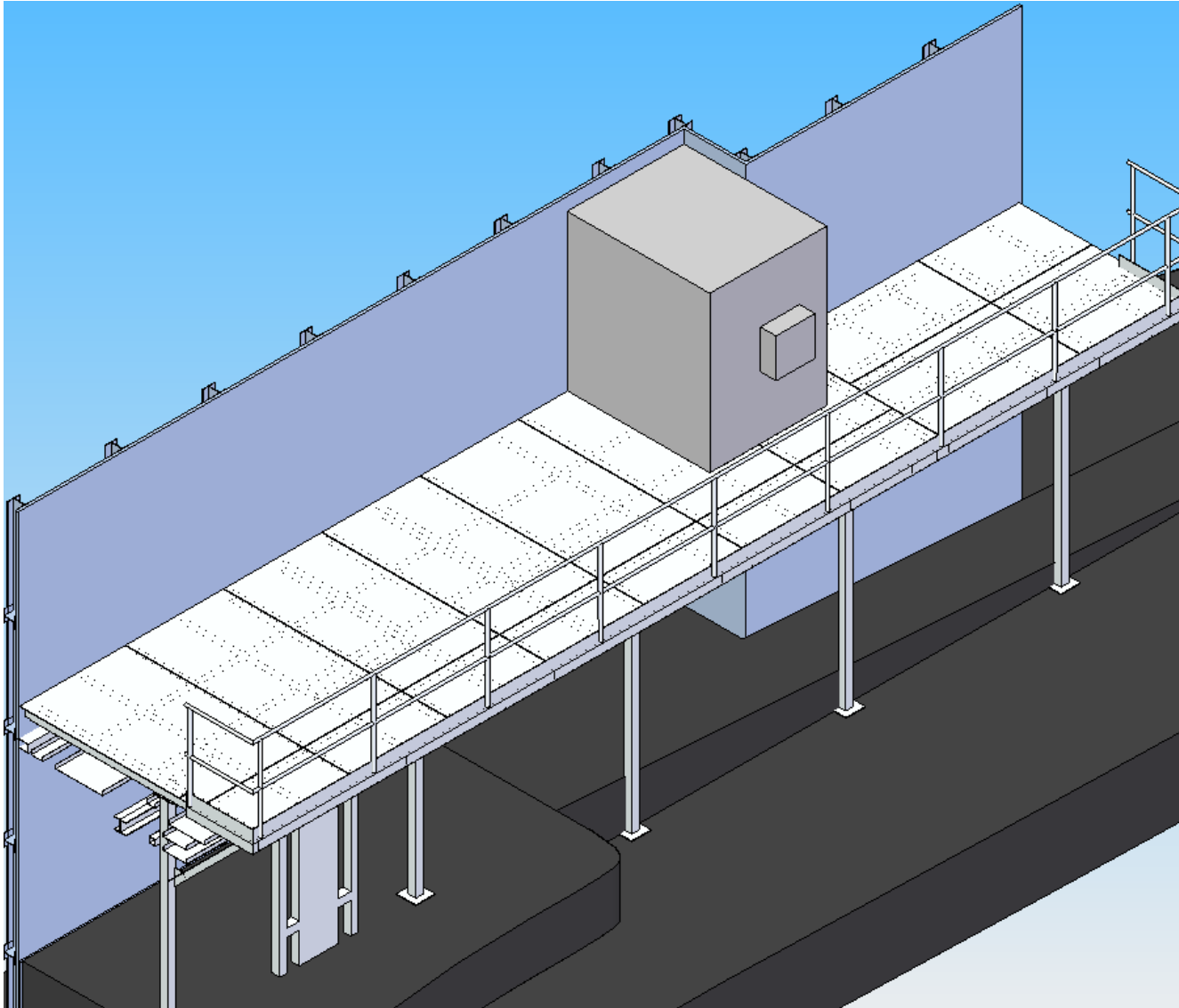

MICE Integration Engineering

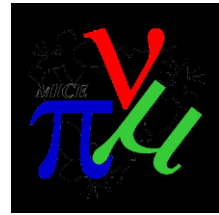

- South Mezzanine change summary

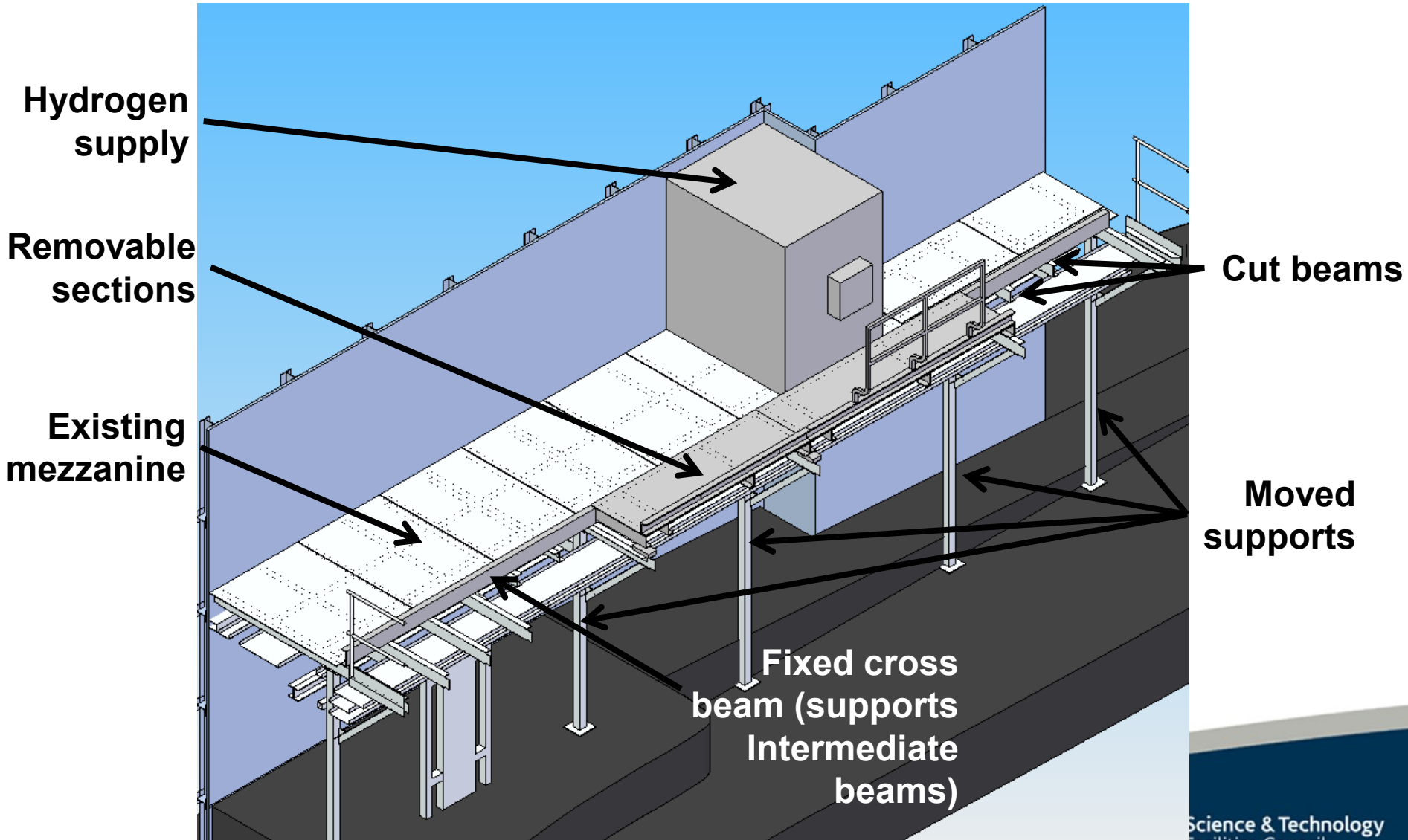

MICE Integration Engineering

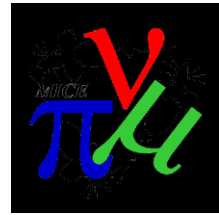

- South Mezzanine change summary

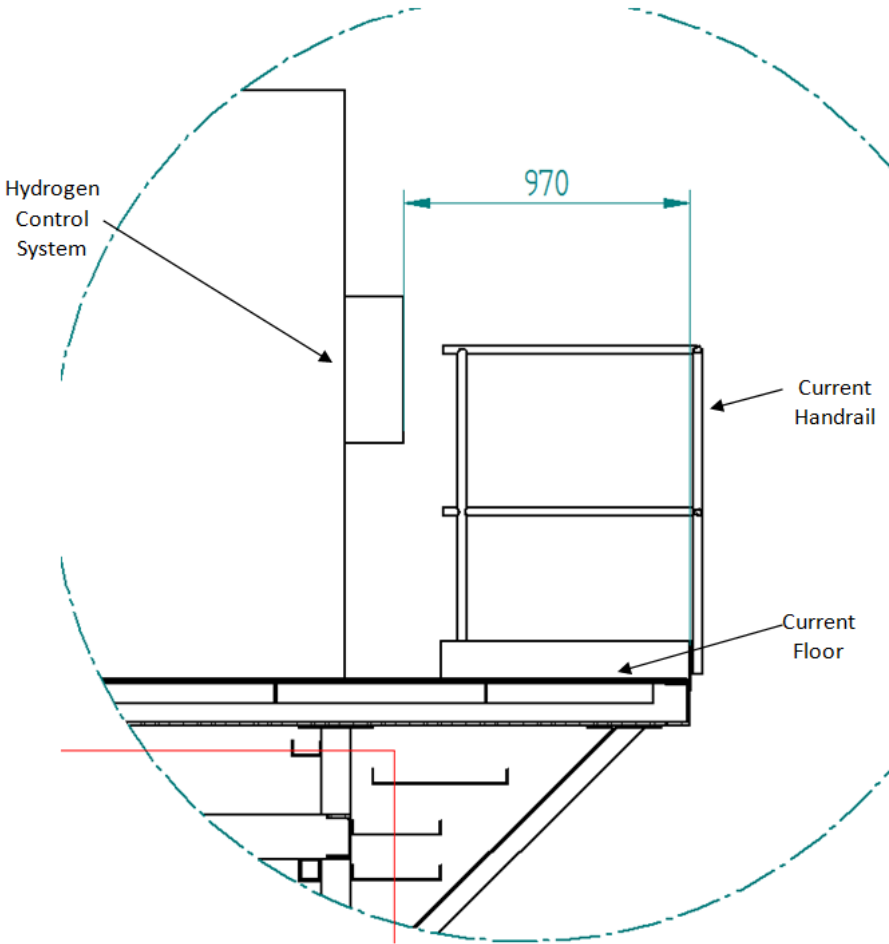

Fig 1: Current South Mezzanine walkway

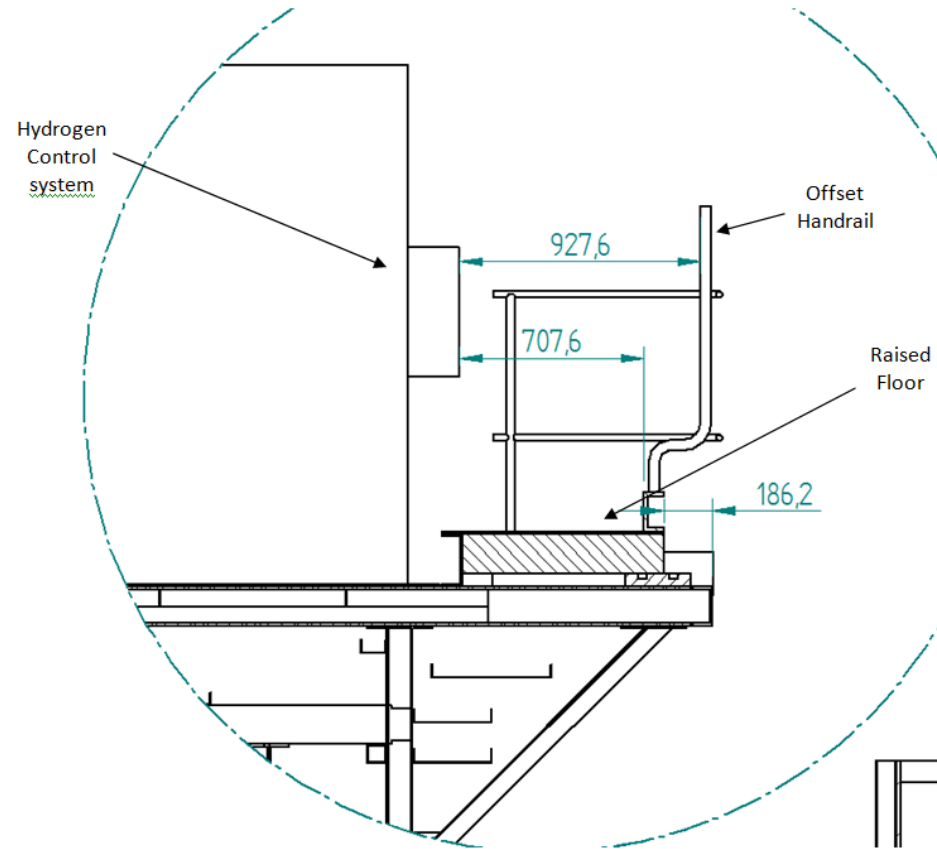
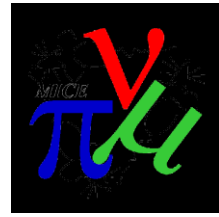

Fig 2: Proposed South Mezzanine walkway with raised floor and offset handrail

MICE Integration Engineering



- South Mezzanine – Before change!
 - » Is the narrow walkway acceptable for safety?
 - » Can the H system frame & pipes be raised to give headroom?
 - » Can H system frame / pipes be temporarily removed to move platforms?
 - » Is the raised floor compatible with the hydrogen racks?
 - » What needs to be installed / moved along the mezzanine walkway? Is it compatible?
 - » Structurally OK?

