

# Proton-Emitting Isotopes near the $N=82$ Shell Closure

Adam McCarter



UNIVERSITY OF  
LIVERPOOL





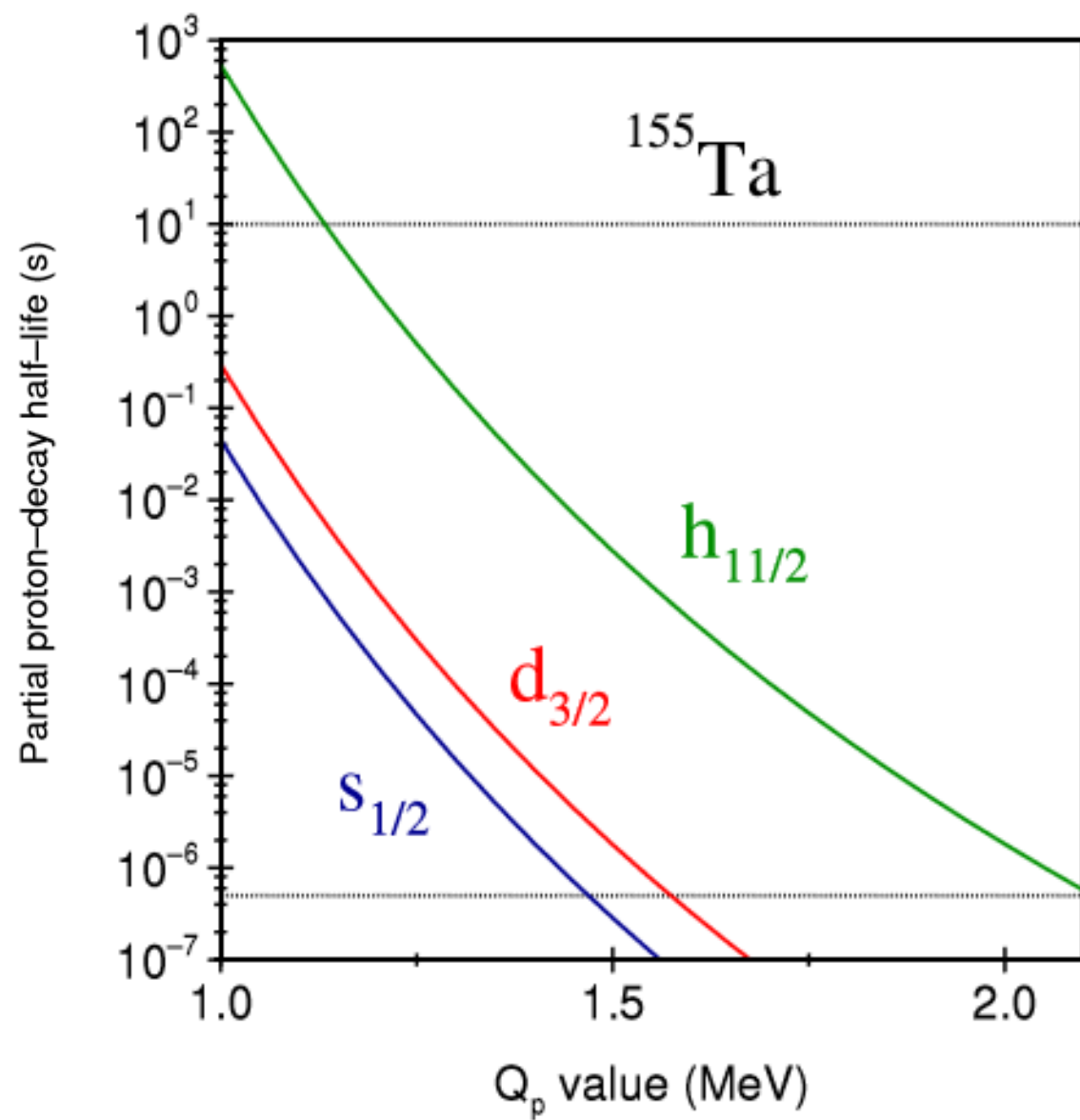
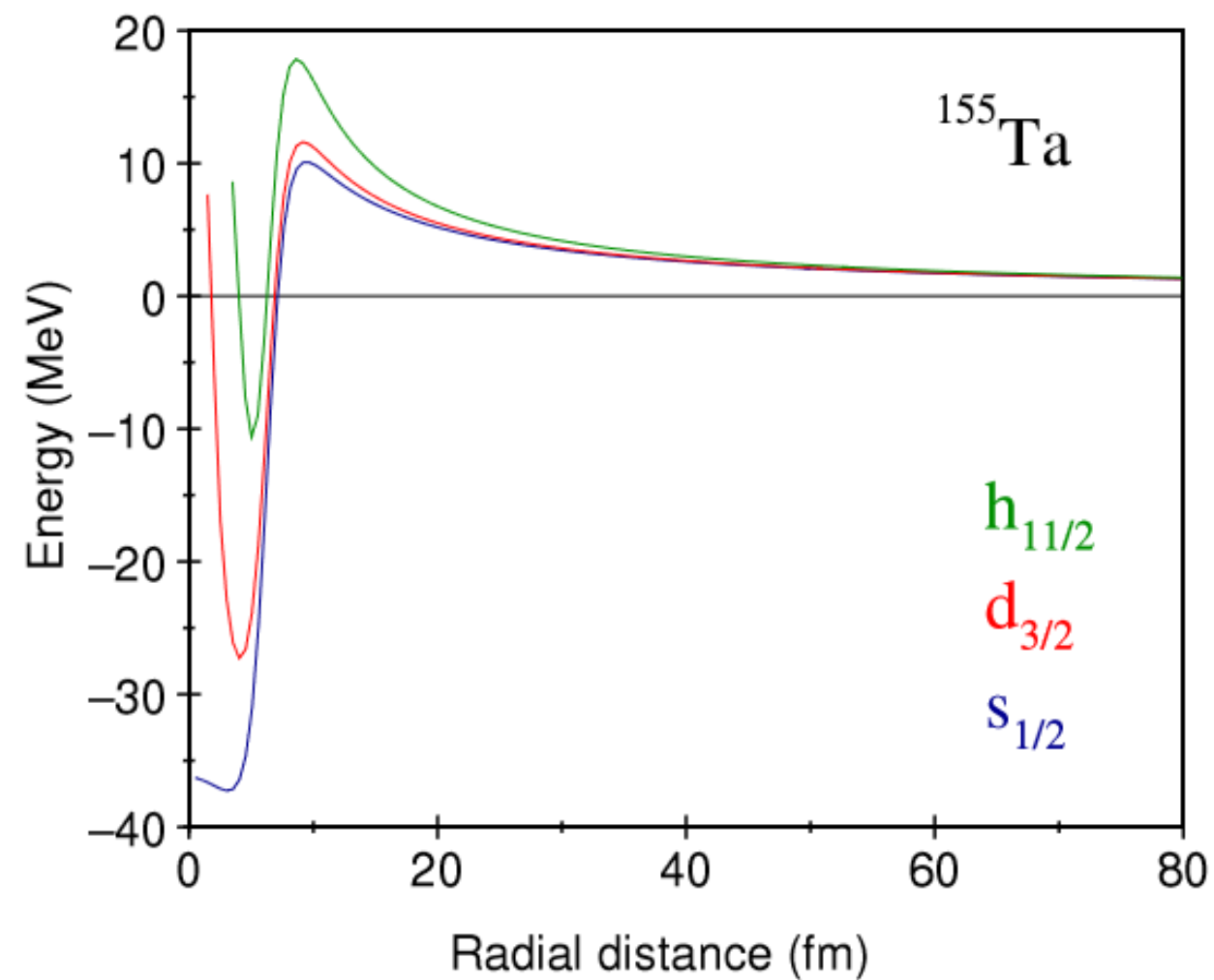

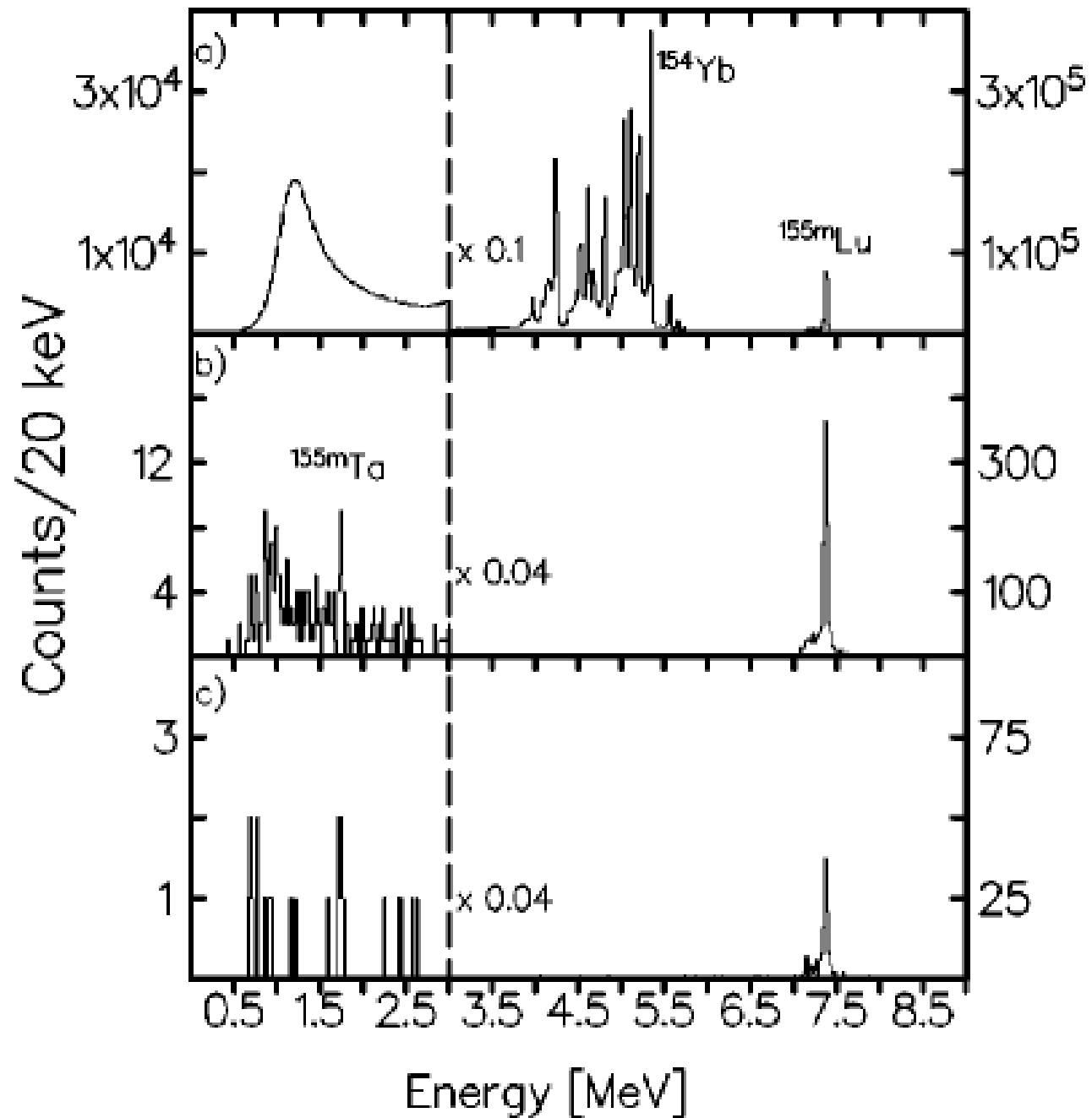
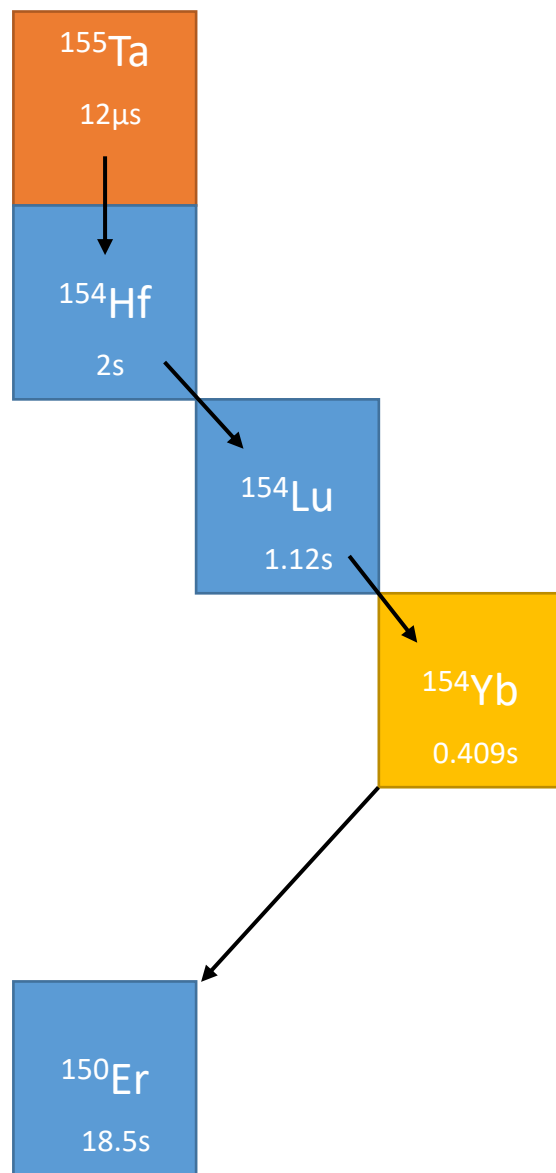



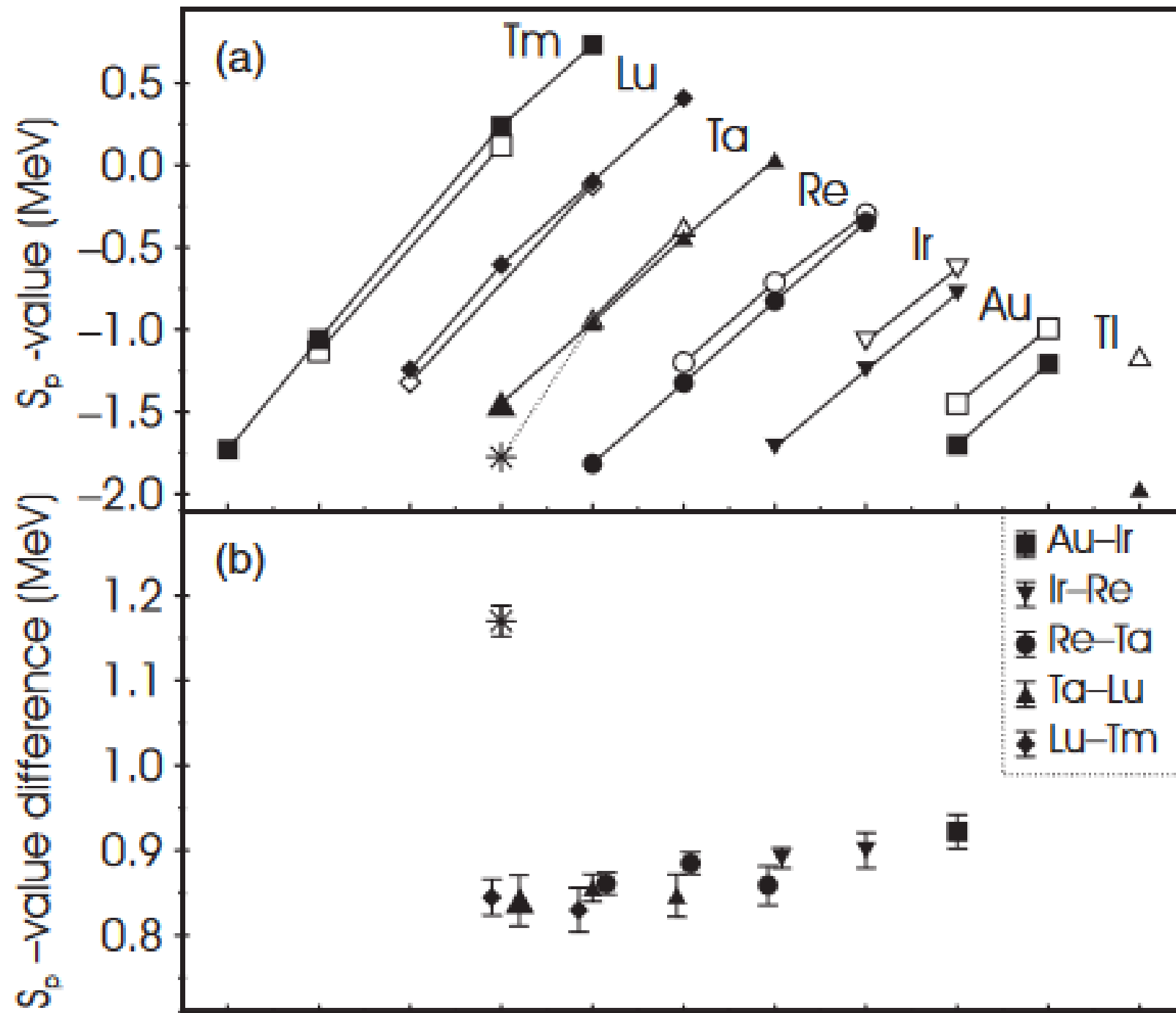

p  
β  
α

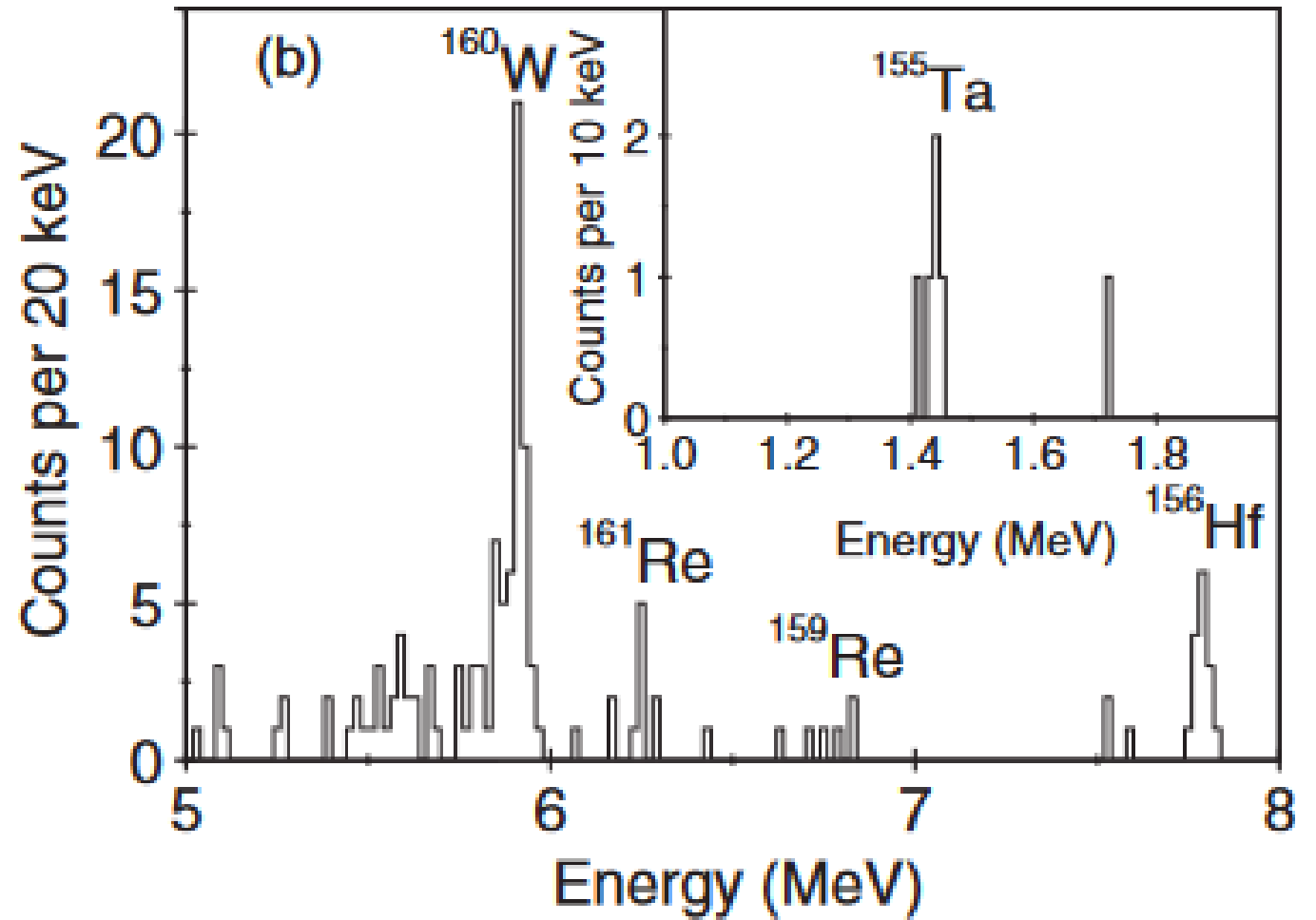
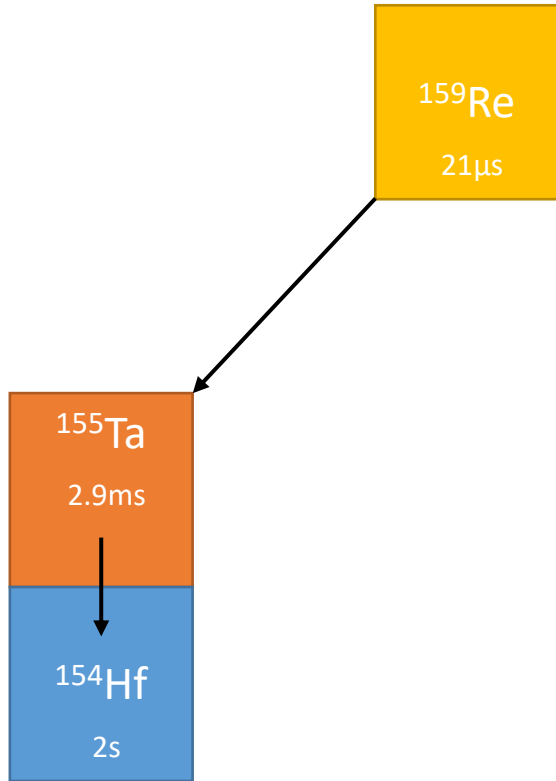

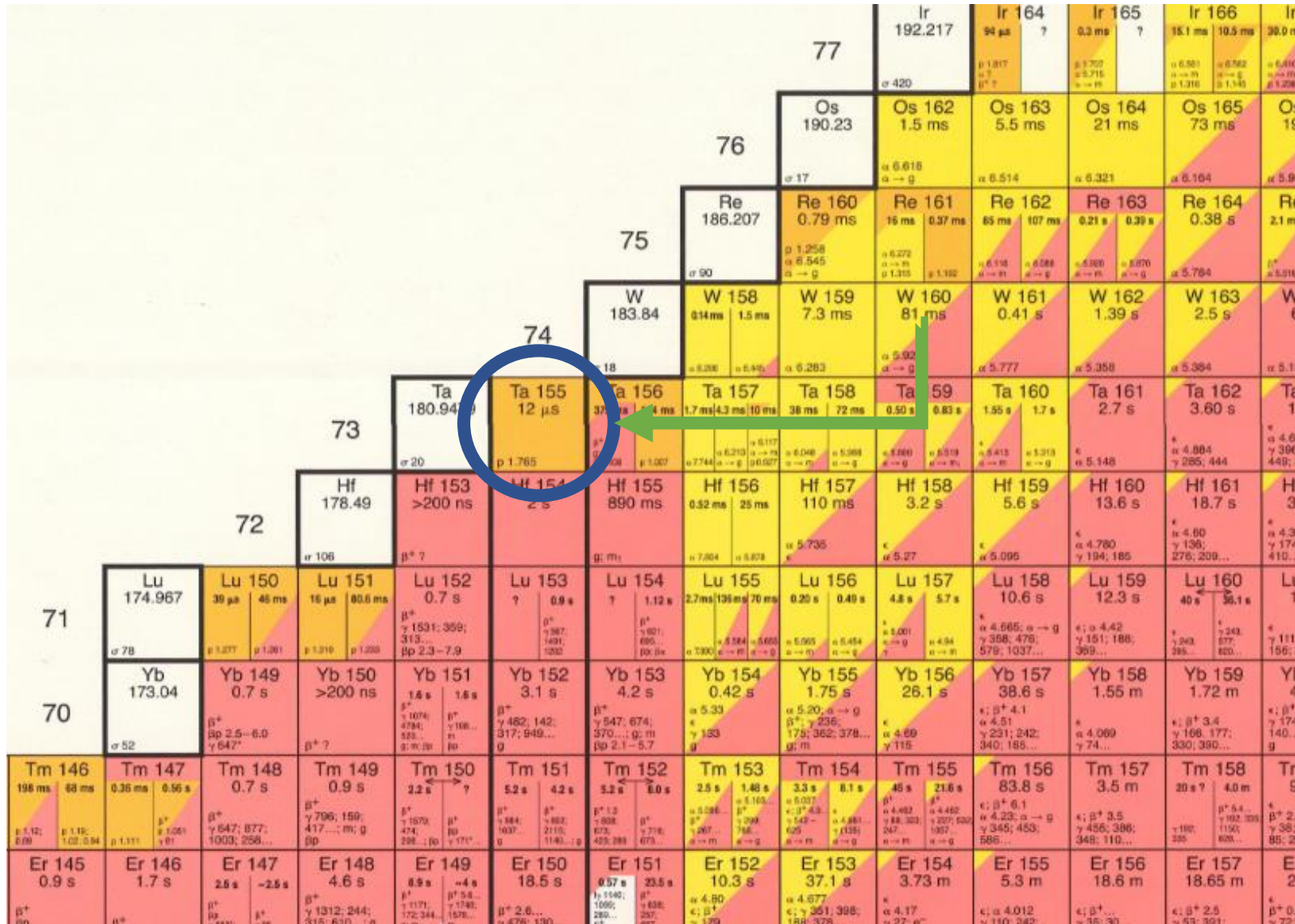



# DSSD

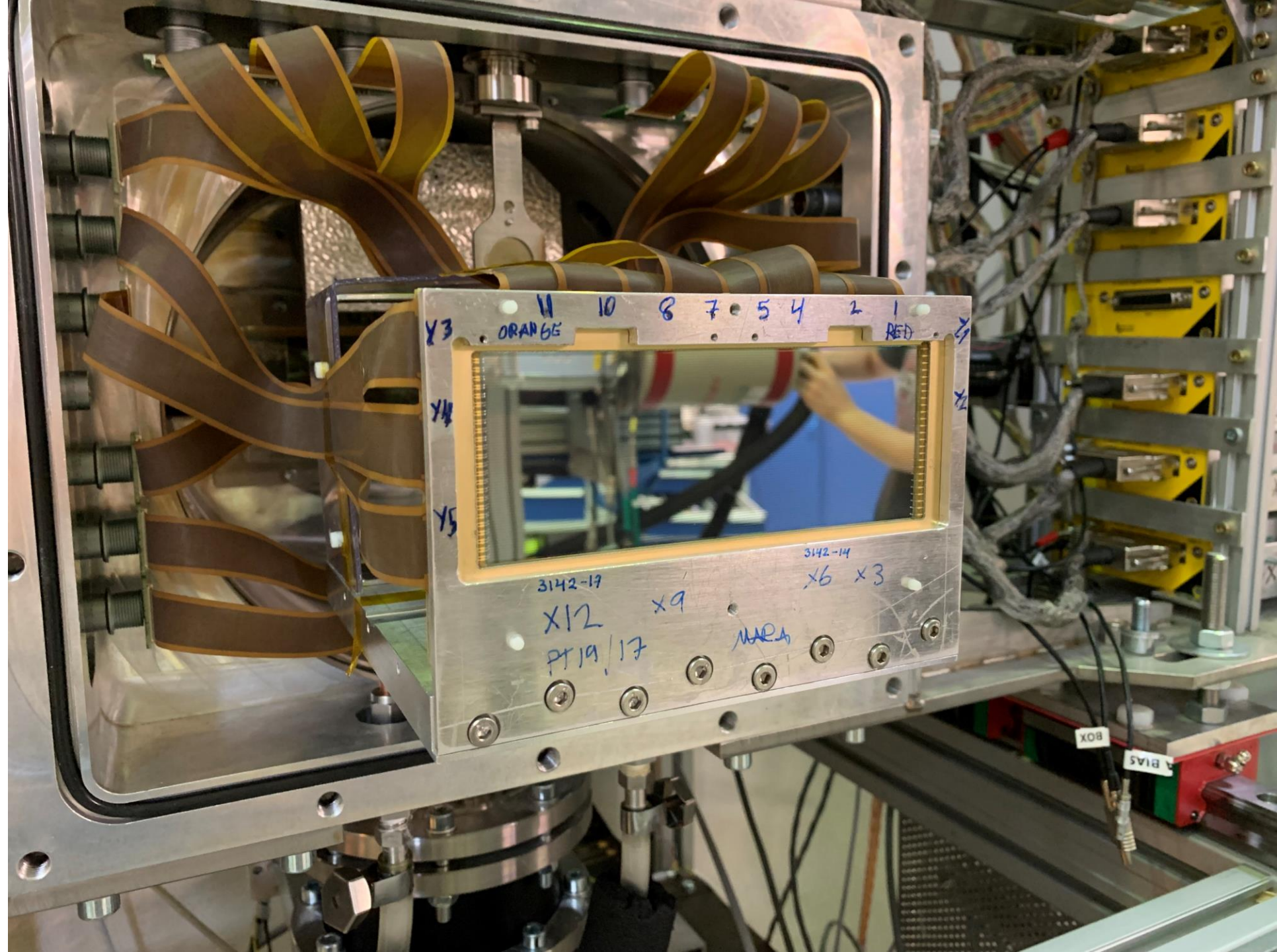



# Raw DSSD Spectrum

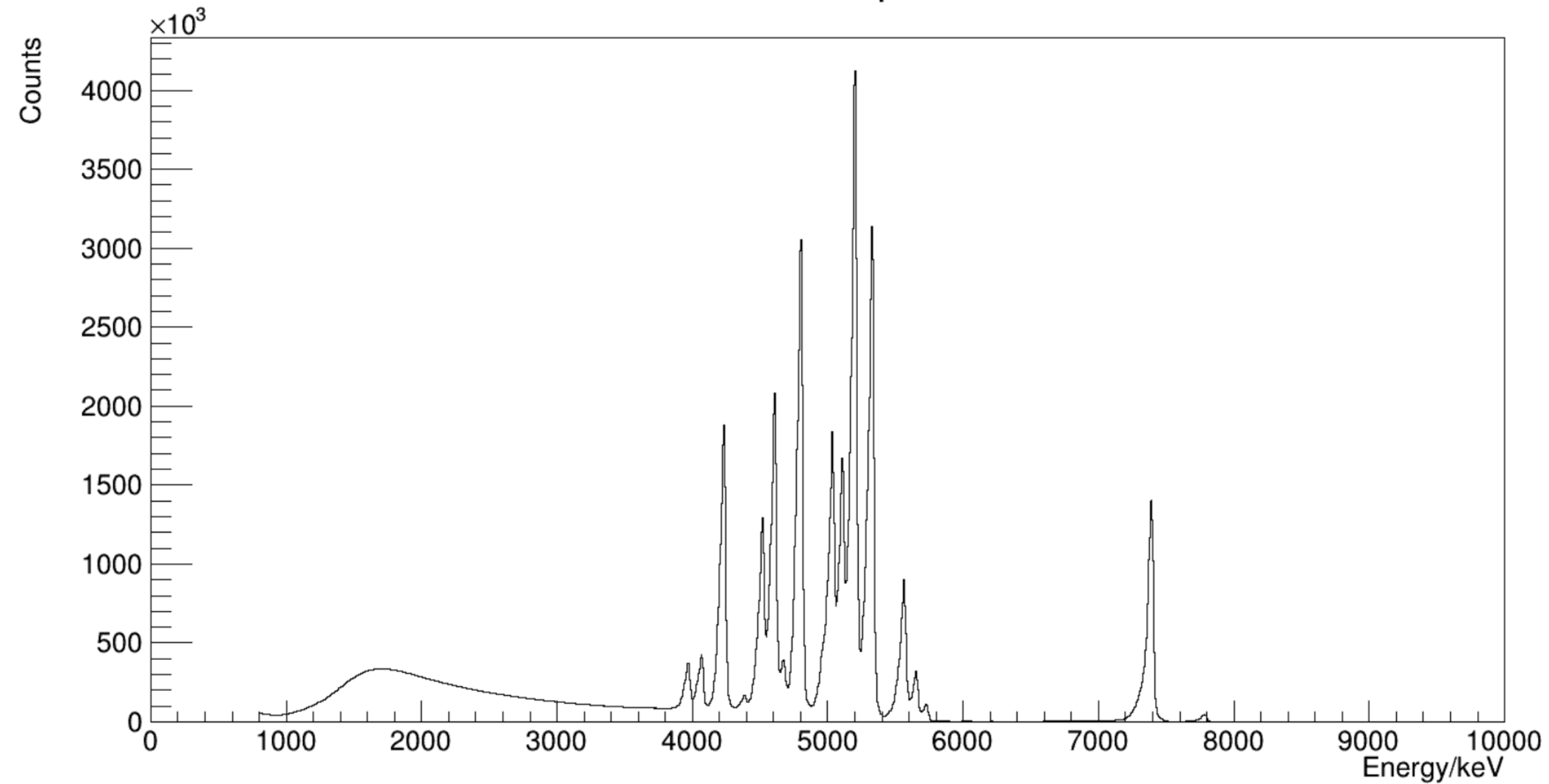

# MARA

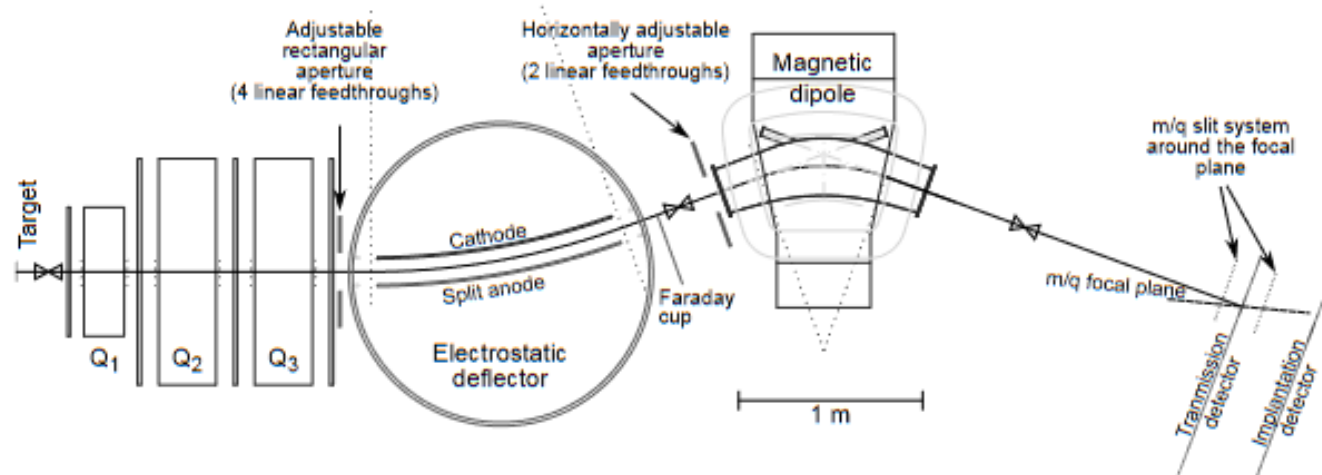
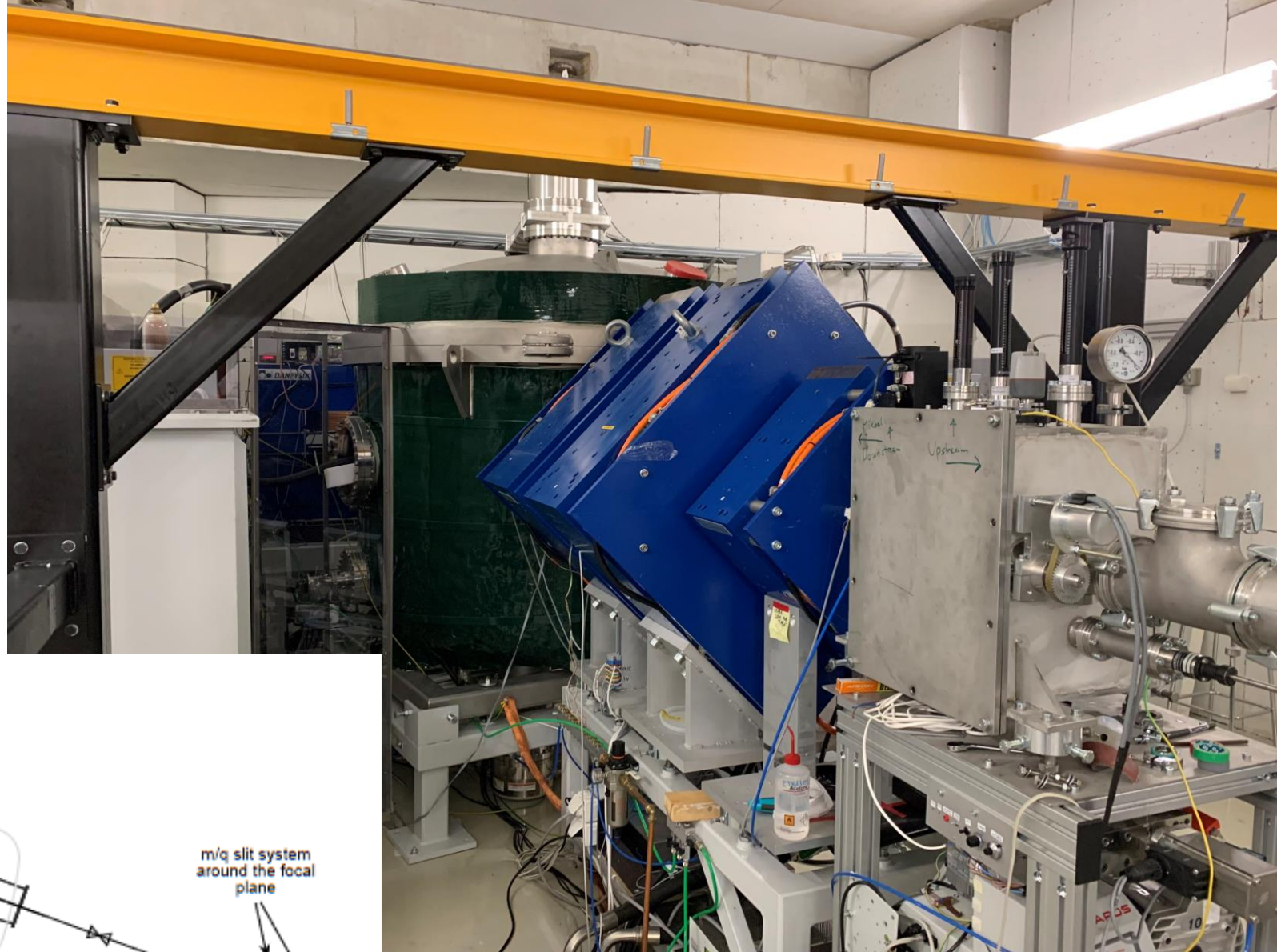



Comparison of Raw DSSD Spectrum (Grey) and Mass Gated DSSD Spectrum (Blue)

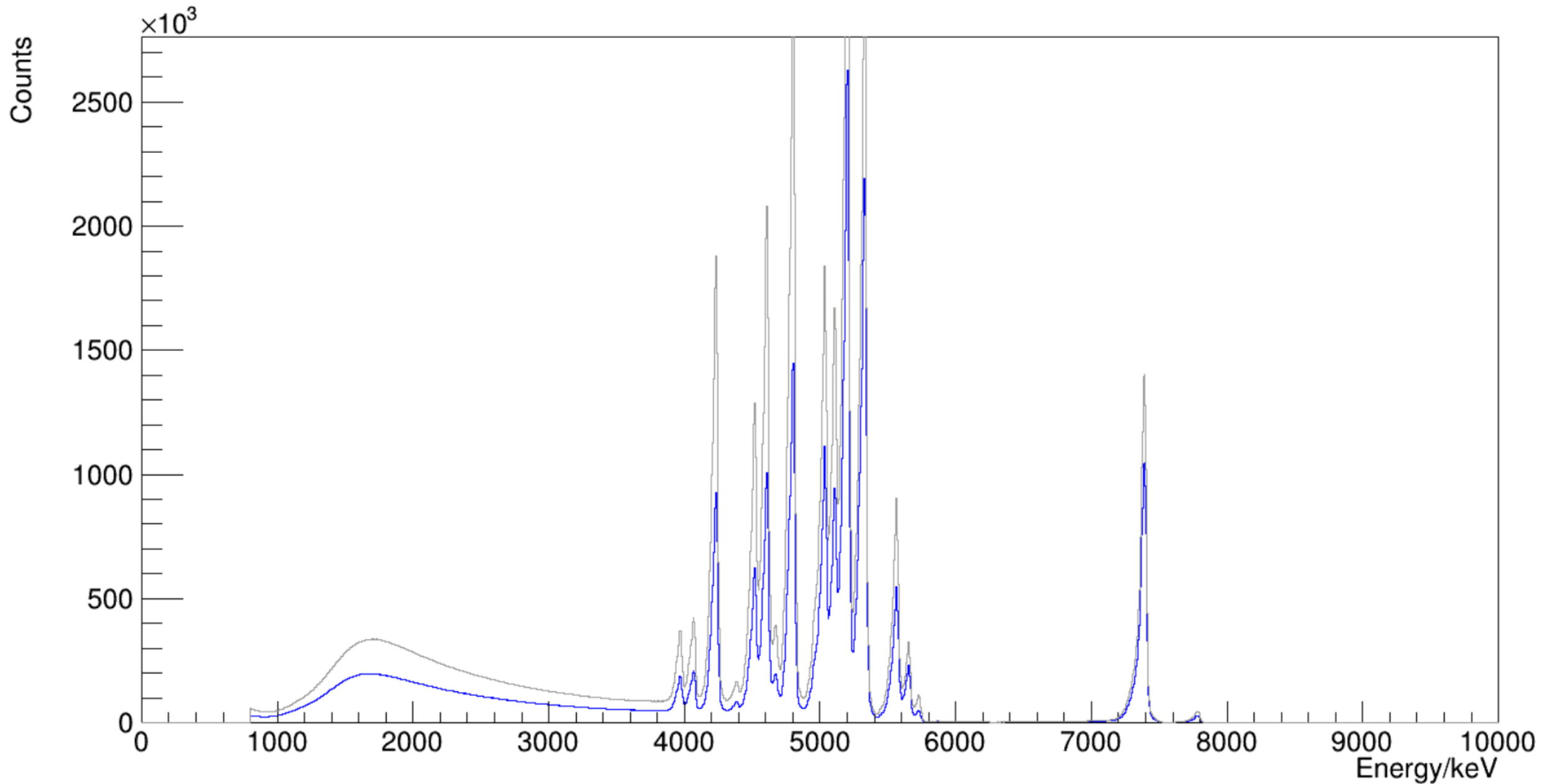

Comparison of Mass Gated DSSD Spectrum (Grey) and Mass + Time Gated DSSD Spectrum (blue)

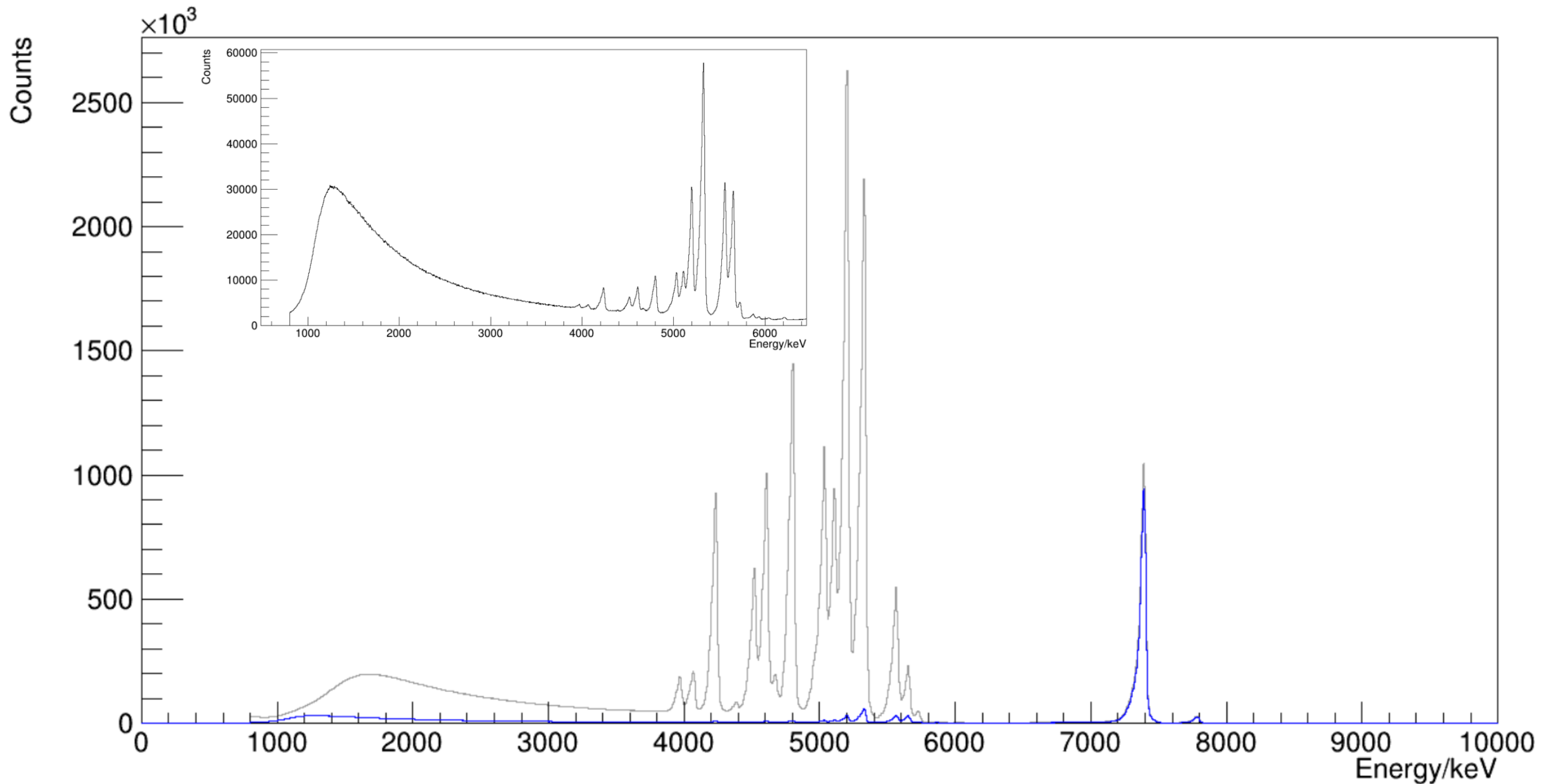



# JYTube

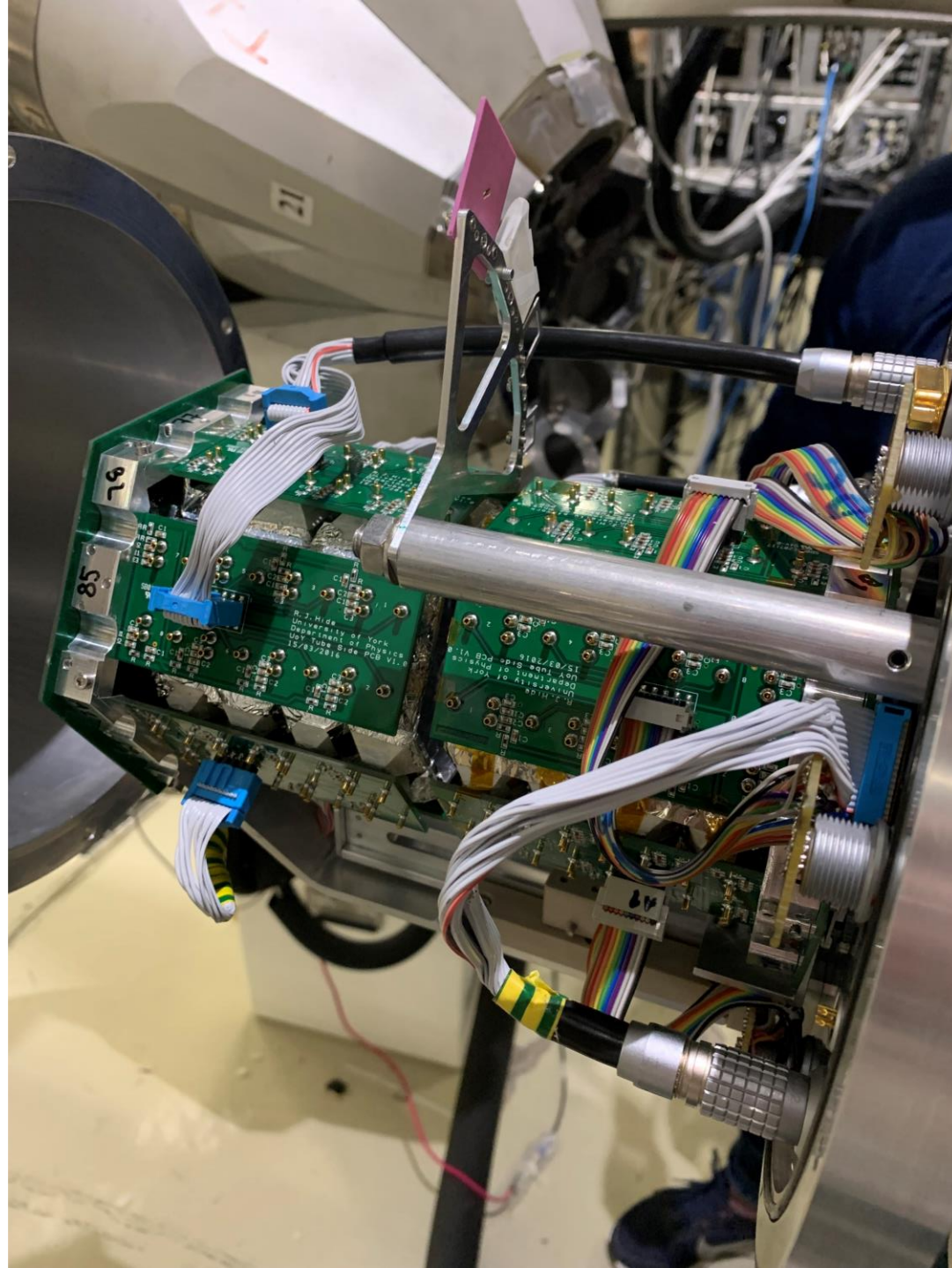

# Tube Fold < 2, Recoil-Decay time < 15ms, Mass = 155

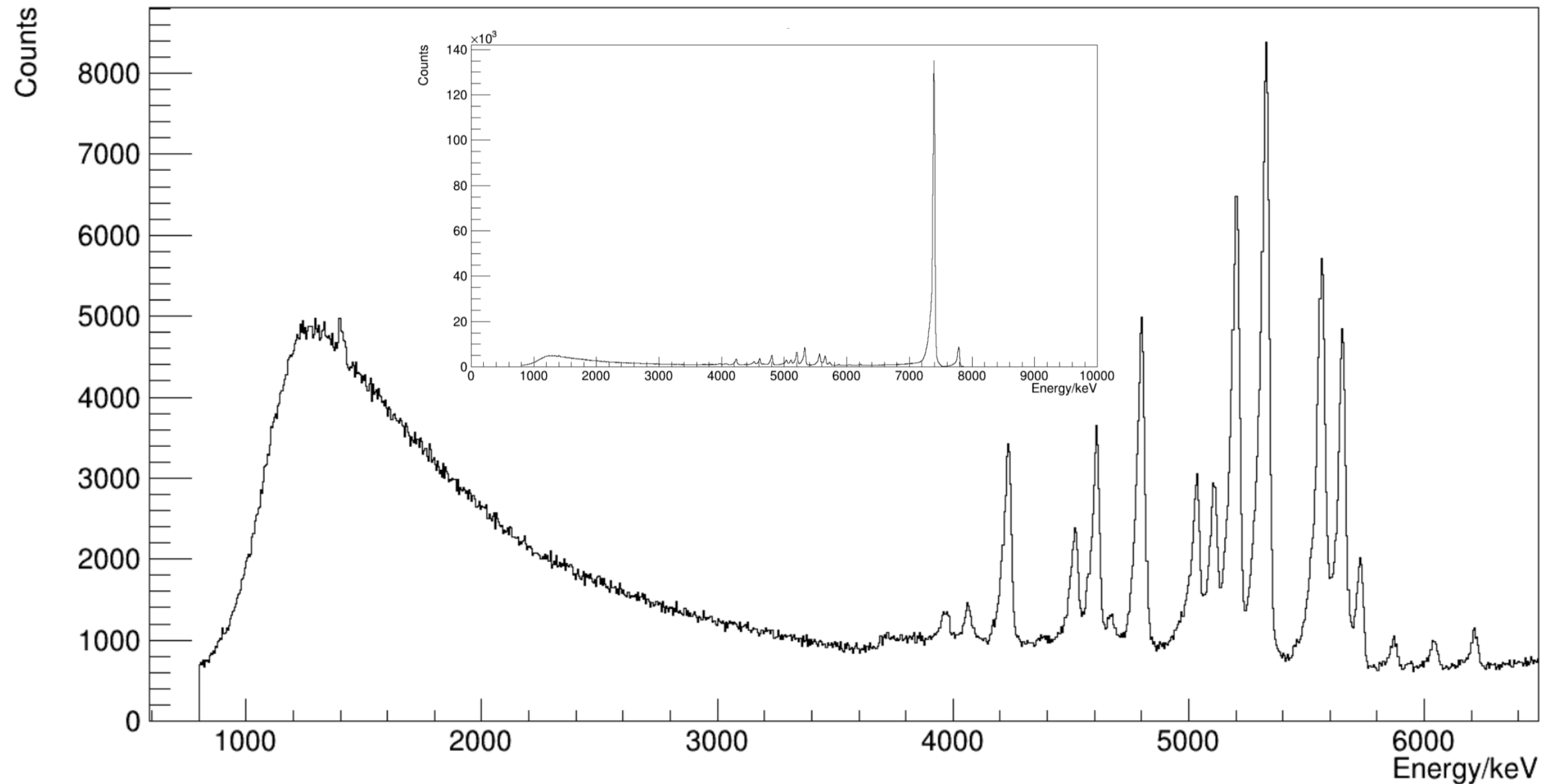



# Tube Fold < 2, Recoil-Decay time < 15ms, Mass = 155, Followed by $^{154}\text{Yb}$ Alpha

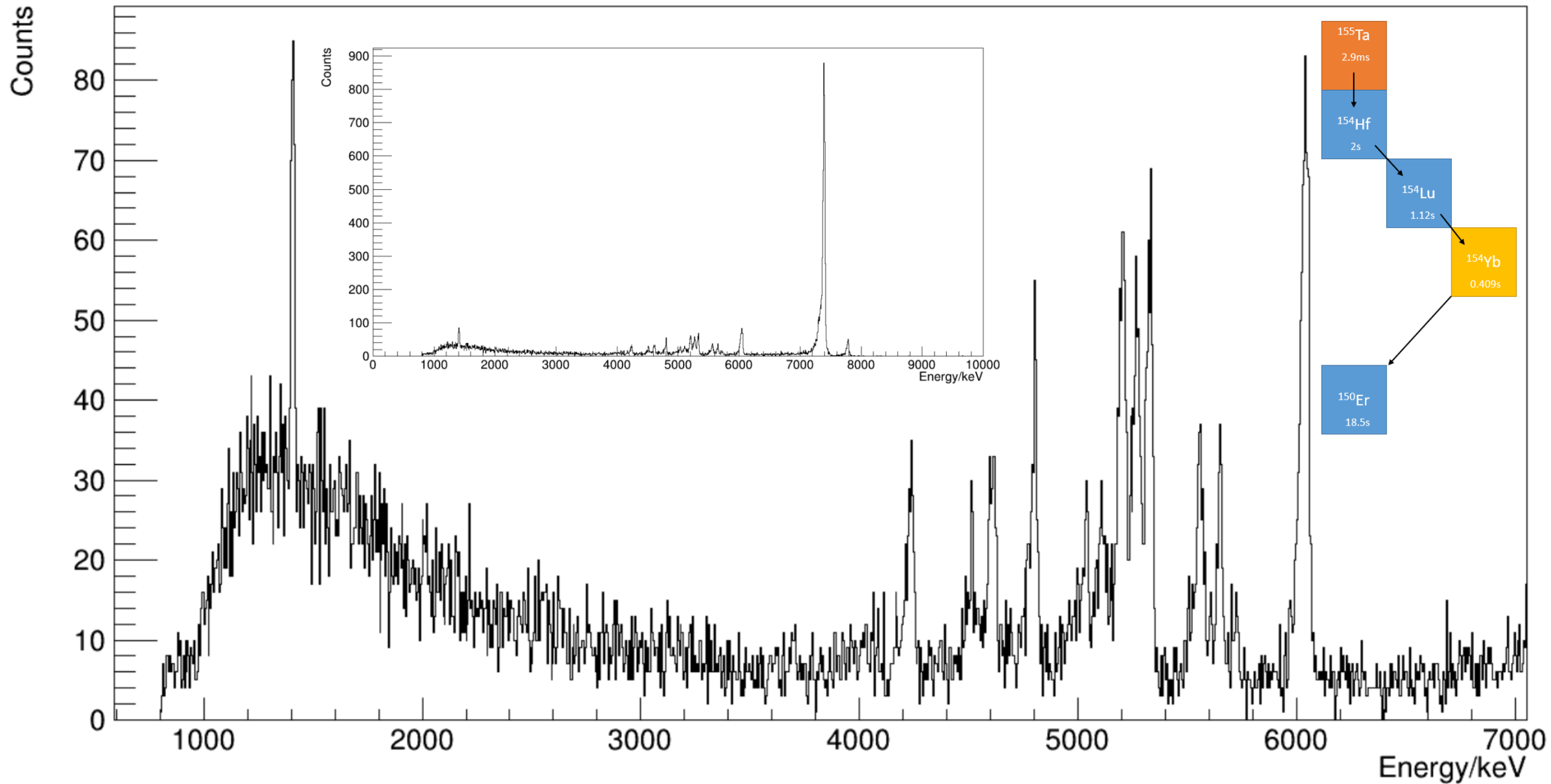

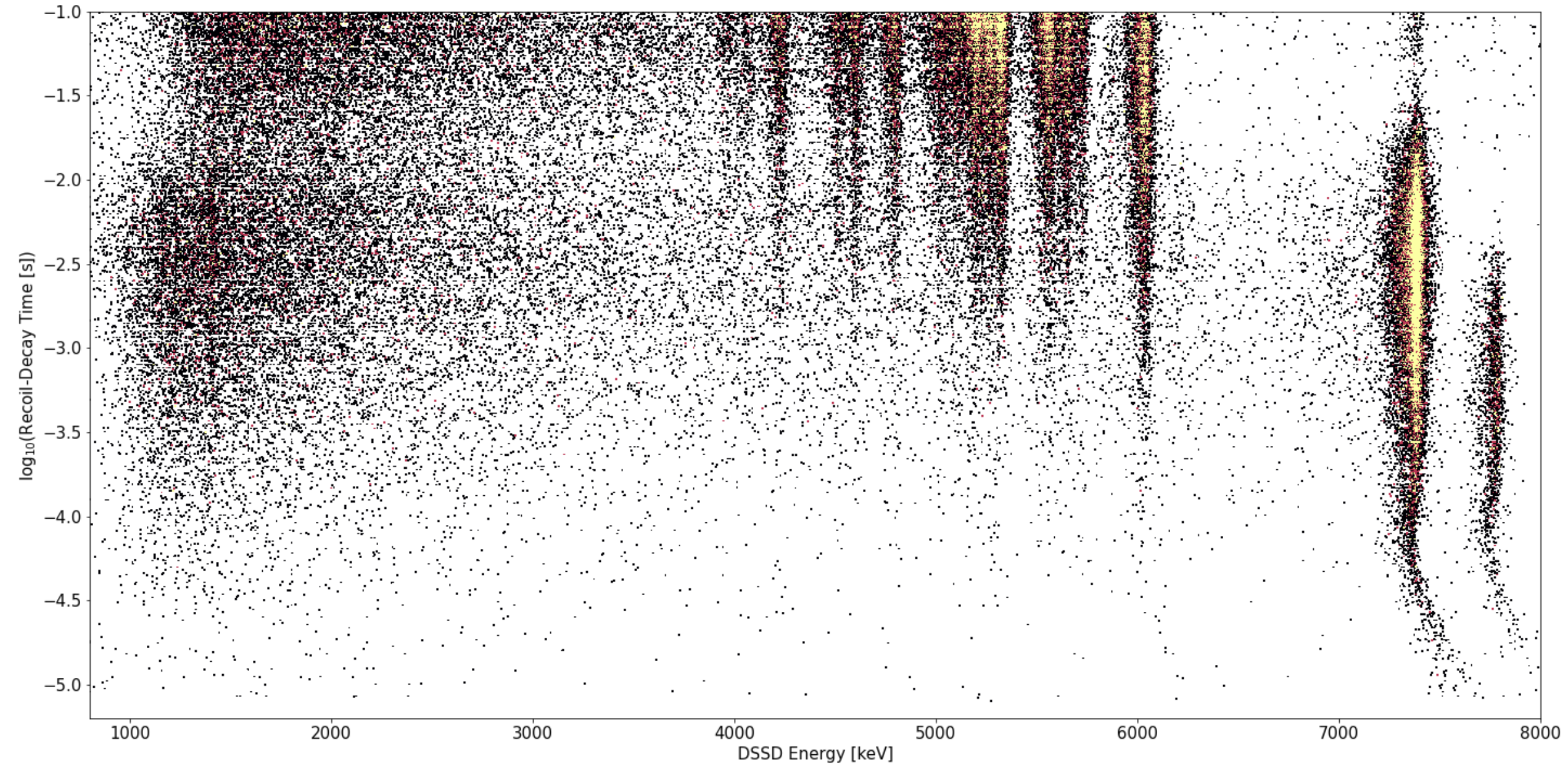



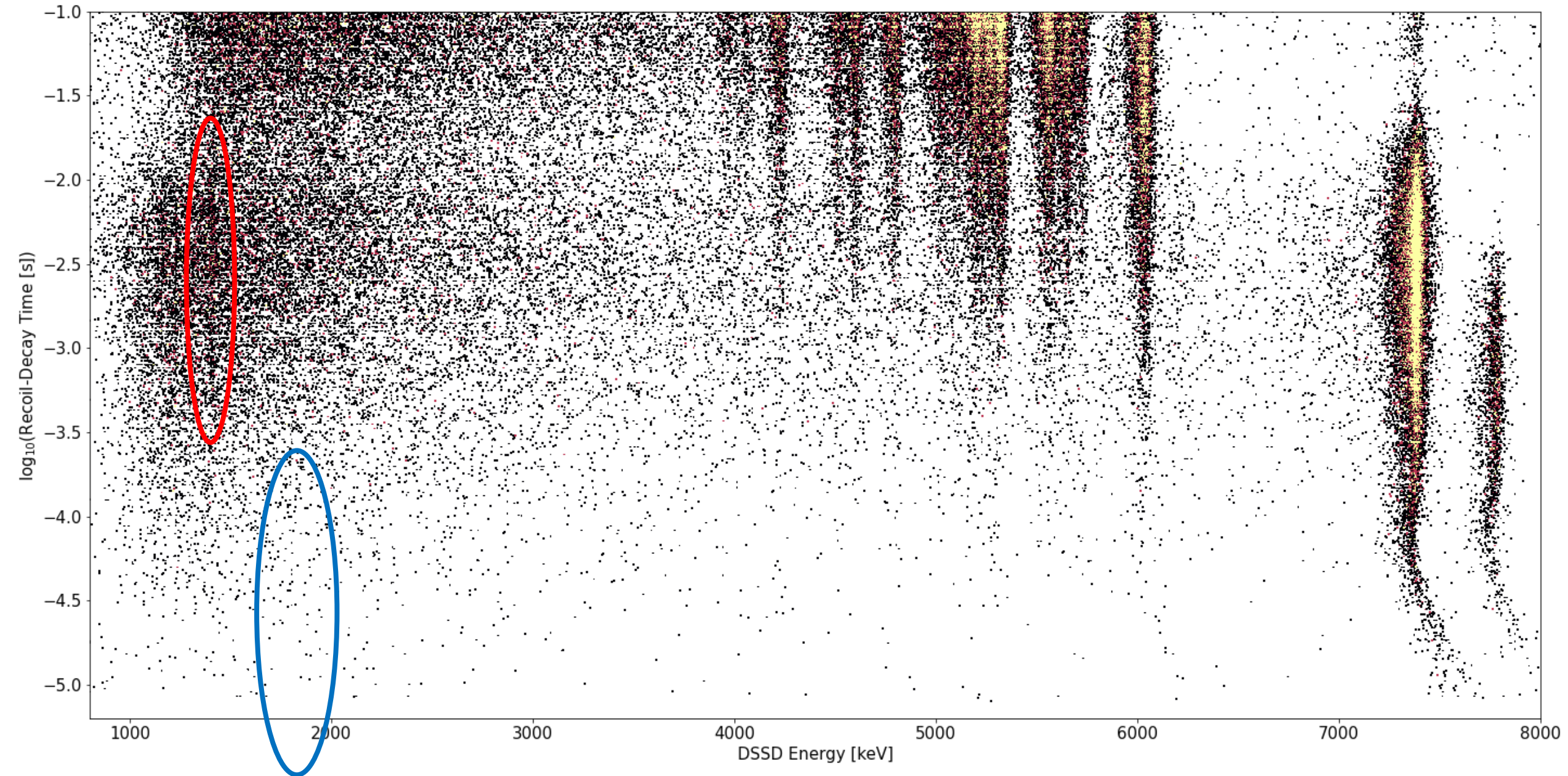



# Focal Plane Germanium Array



$^{149}\text{Ho}$

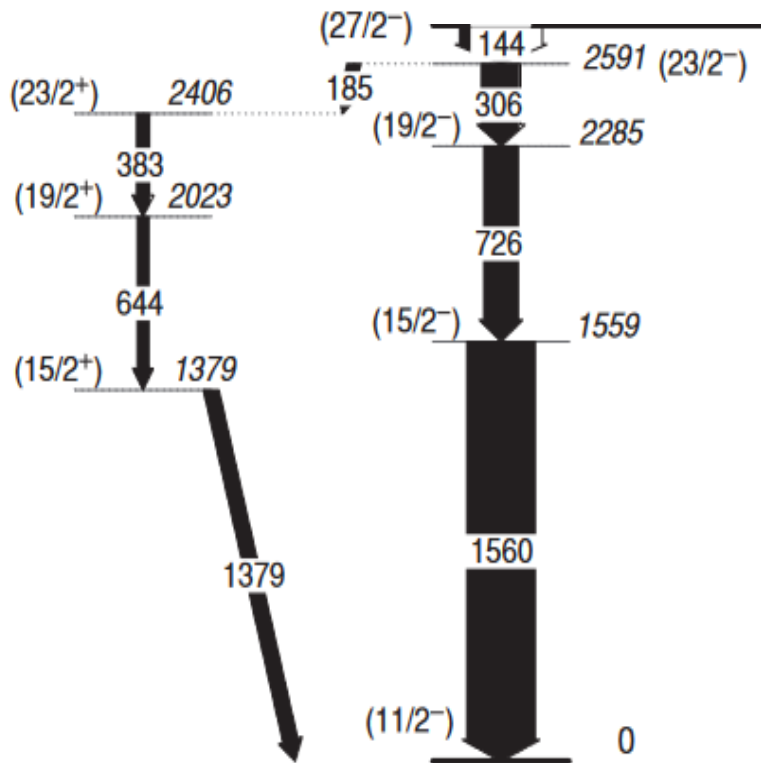

$^{151}\text{Tm}$

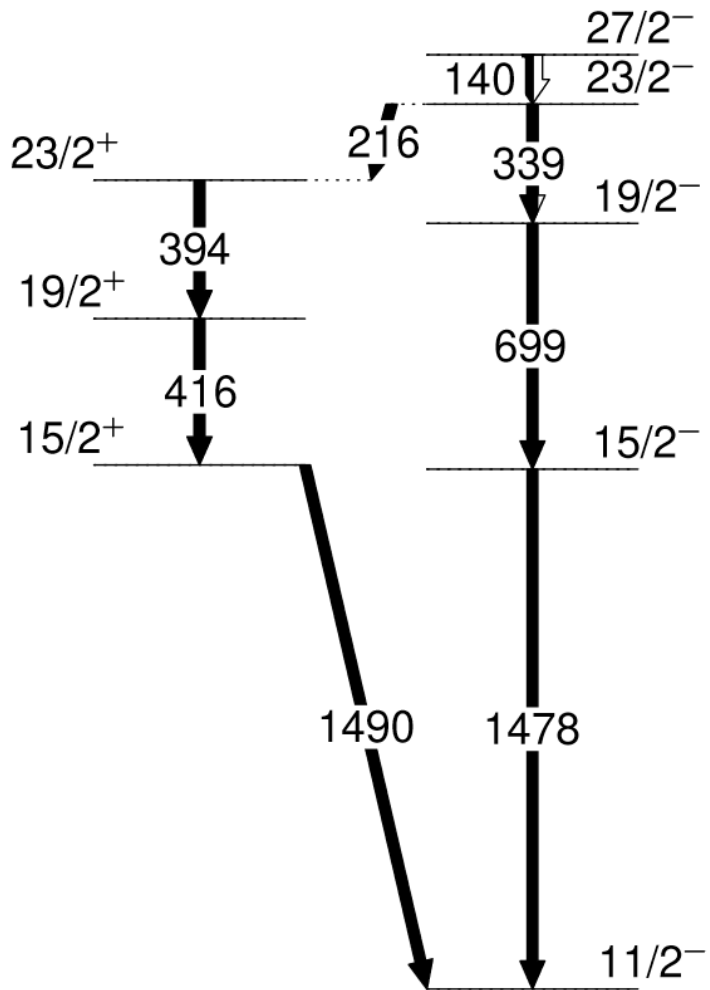

$^{153}\text{Lu}$

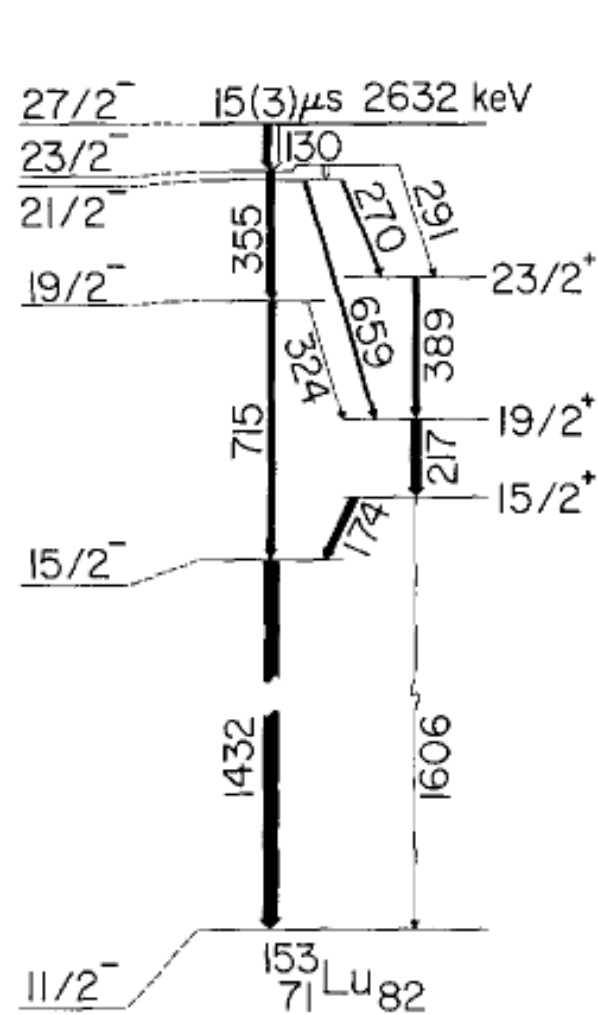

N=82 Isomers

Gammas in Coincidence with  $^{155}\text{Ta}$  Protons

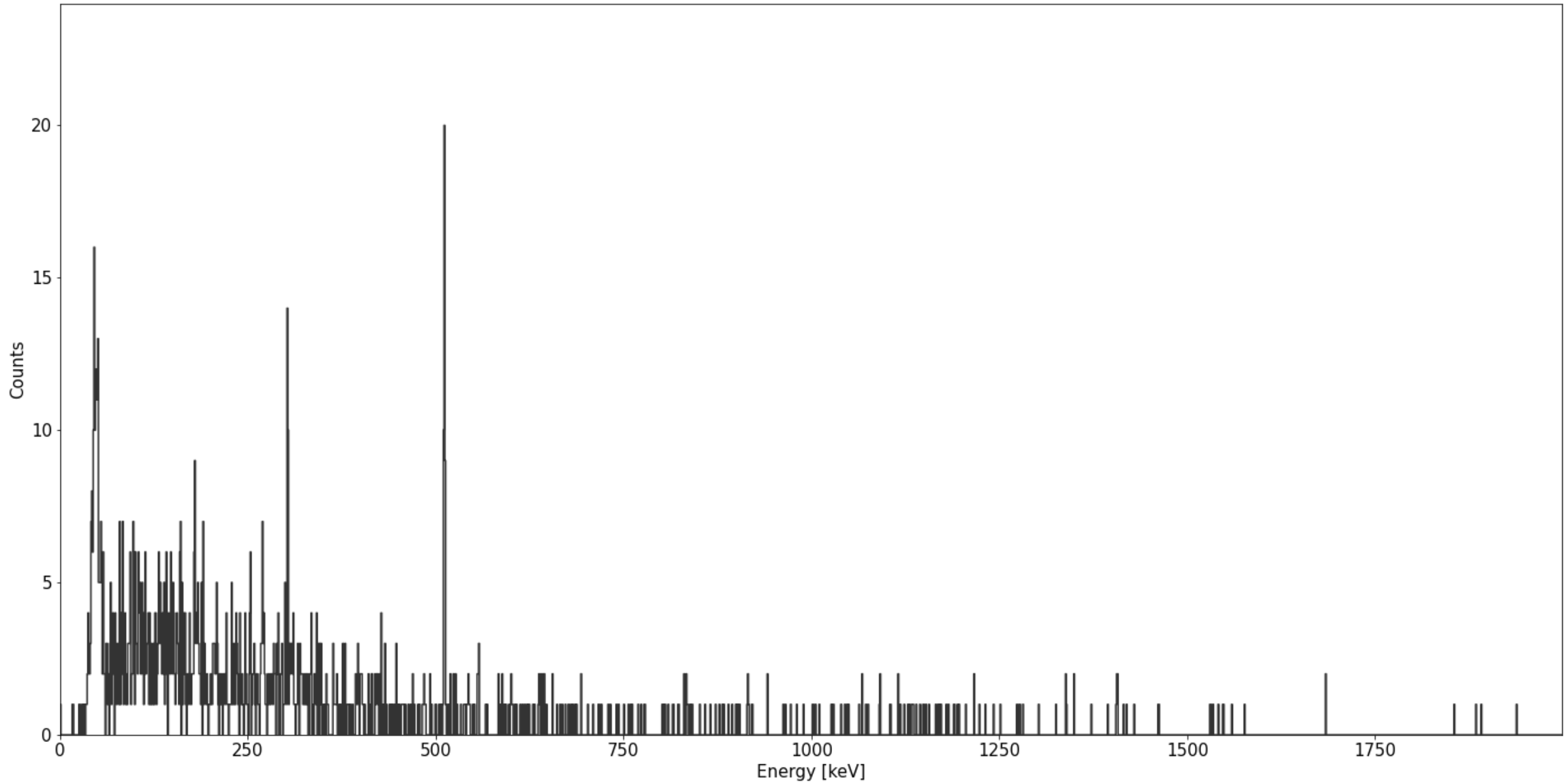



Gammas in Coincidence with  $^{155m}\text{Lu}$  Escape Alphas

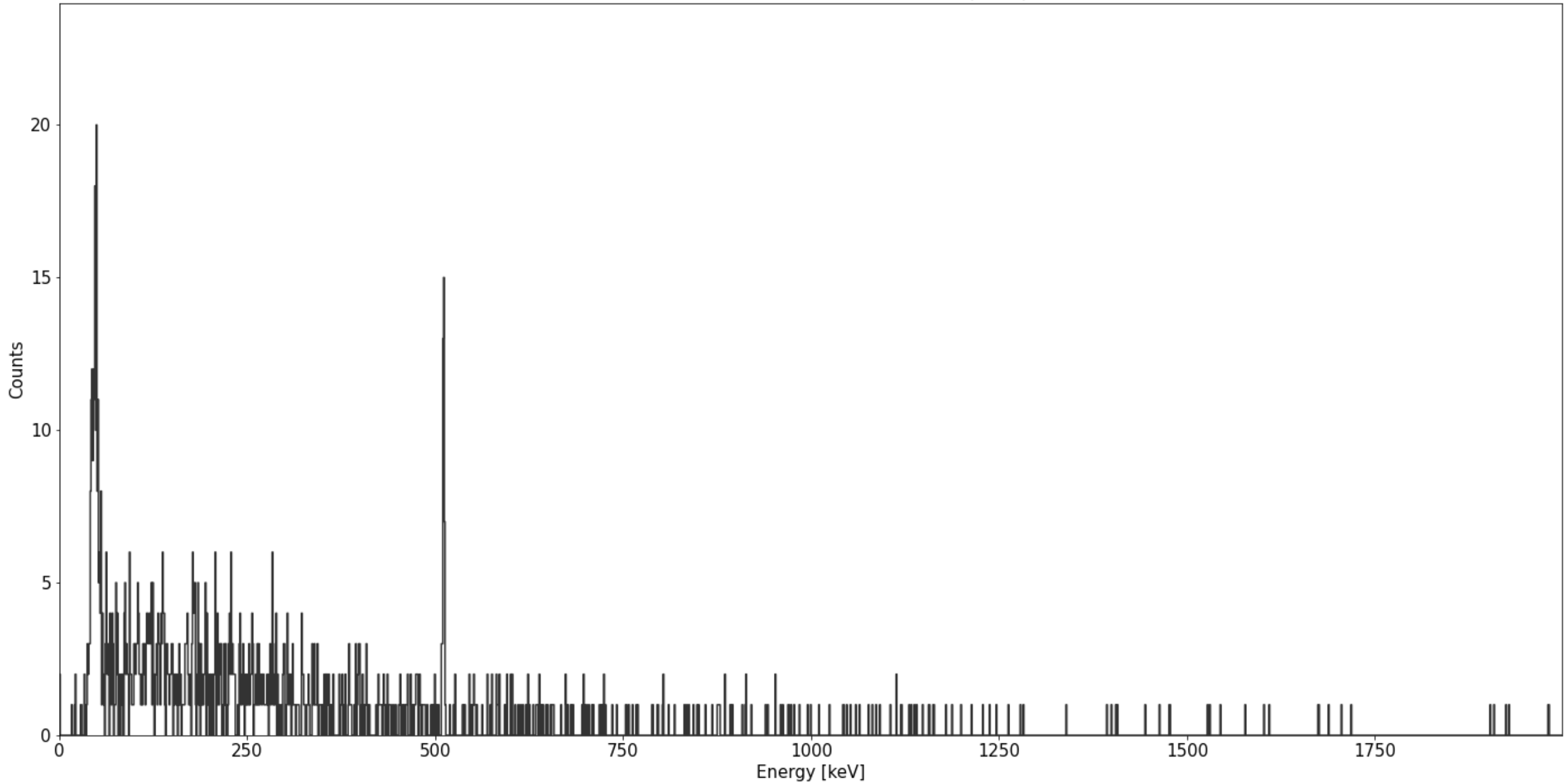

Gammas in Coincidence with  $^{155}\text{Ta}$  Protons Correlated with  $^{154}\text{Yb}$  Alphas

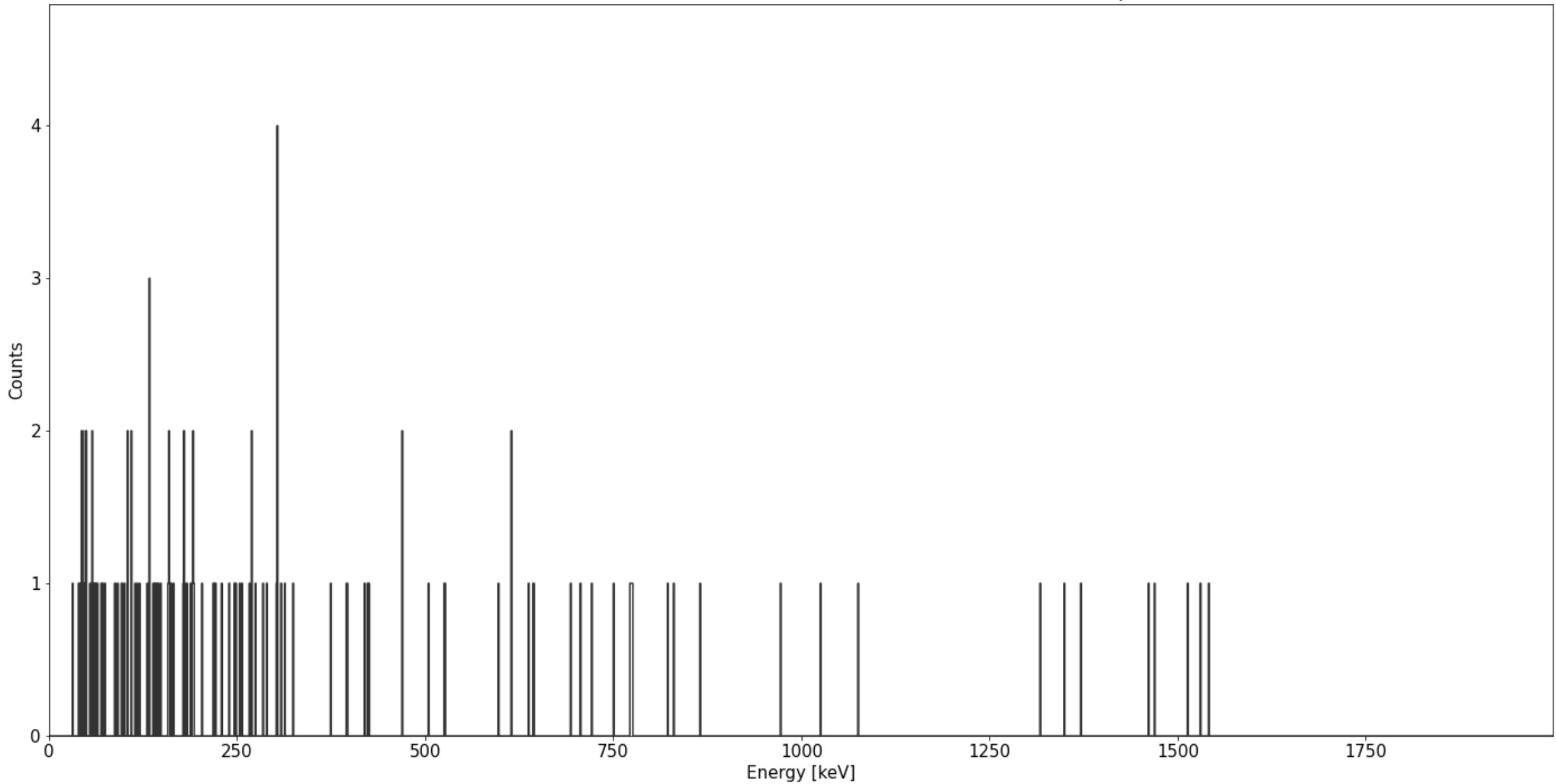

# Conclusion

- Direct production of proton-emitting state in  $^{155}\text{Ta}$ .
- Consistent with production following  $^{159}\text{Re}$  alpha decays.
- No obvious sign of short-lived proton reported by Uusitalo et al.
- Evidence of  $\mu\text{s}$  isomer.



# Thanks!

- University of Liverpool

- David Joss
- Robert Page
- Betool Alayed
- Shiyamjith Nathaniel
- Conor Sullivan
- Holly Tann
- Lorna Waring

- University of the West of Scotland

- Hamid Ayatollahzadeh
- George Beeton
- James Deary
- James Keatings
- David O'Donnell
- John Smith

- STFC Daresbury Laboratory

- Marc Labiche
- Philippos Papadakis

- Slovak Academy of Sciences

- Monika Birova
- Martin Venhart

- University of York

- James Cubiss
- Christopher Page

- University of Jyväskylä

- Juha Uusitalo
- Andy Briscoe
- Kalle Auranen
- Ville Bogdanoff
- Tuomas Grahn
- Paul Greenlees
- Andres Illana Sison
- Henna Joukainen
- Rauno Julin
- Henri Jutila
- Matti Leino
- Jussi Louko
- Minna Luoma
- Joonas Ojala
- Janne Pakarinen
- Adrian Montes Plaza
- Panu Rahkila
- Jorge Romero
- Panu Ruotsalainen
- Jan Sarén
- Alvaro Tolosa Delgado
- Eetu Uusikylä
- George Zimba