

A Review of Ultralow Temperature and Low Background Facilities at Fermilab

Matthew Hollister (with contributions from Daniel Bowring, Dan Baxter, Greg Tatkowski, Aaron Chou, Chris James, Andrew Sonnenschein and others)

Fermi National Accelerator Laboratory

March 20, 2024

FERMILAB-SLIDES-24-0049-SQMS

Introduction

- Fermilab hosts a number of different cryogenic test facilities suitable for development of quantum sensors and qubits.
- In addition to those test stands operated by SQMS, there are additional stands operated by QSC and by individual PIs and Projects
- This talk is not intended to dig very deeply into science results or detailed capabilities, but more to give an overview of what's available as background for later discussion
- Broadly divided into three types of test stands:
 1. Conventional mK cryostats
 2. Cryogenic test stands with magnets
 3. Underground / Low Radioactive Background test stands

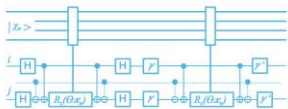
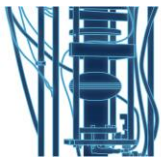

Conventional Test Stands

- As part of the SQMS infrastructure, a new quantum lab with a fleet of 5 Bluefors XLD1000 fridges was commissioned last year.
- All fridges include RF readout lines, extended tail sets for larger experiments, and potential upgrades for optical access.
- Currently being used for a mixture of superconducting cavity experiments and qubit device testing.

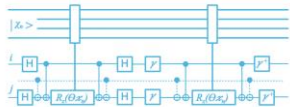

Conventional Test Stands (continued)

- Two additional XLD1000 test stands that pre-date SQMS

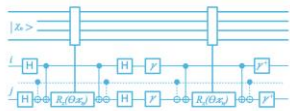
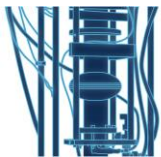
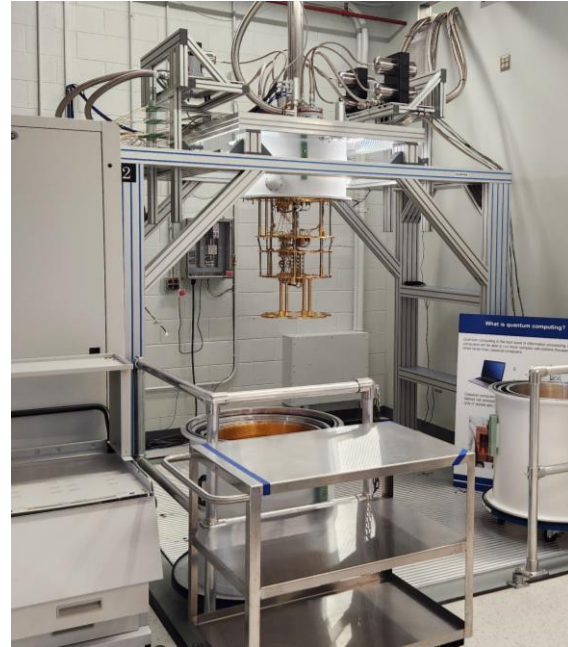

Colossus

Proposed very large mK cryostat developed as part of the SQMS proposal – construction expected to begin in 2026



Exterior of the existing Solenoid Test Facility at Fermilab (Image: Fermilab)

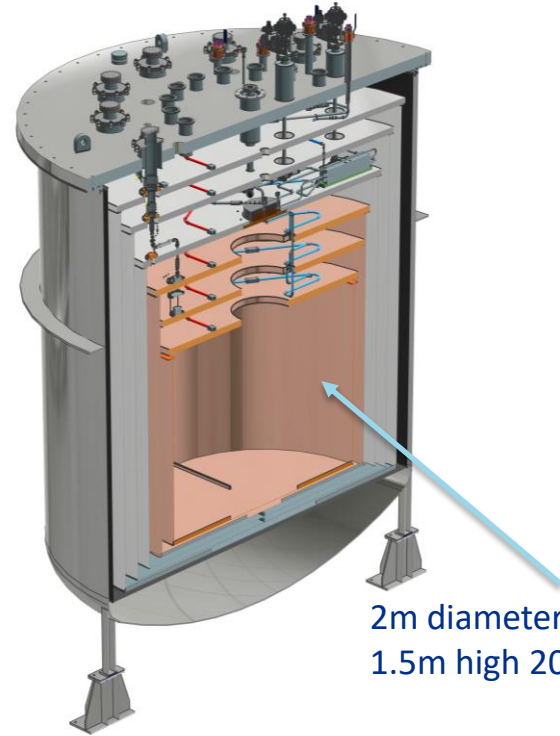

2m diameter volume x
1.5m high 20-mK space

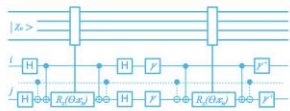
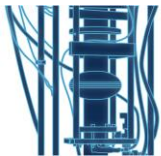

Magnet Test Stands

- Long term involvement of Fermilab in experiments on axion detection, most recently the Axion Dark Matter Experiment (ADMX) based at University of Washington.
- Considerable interest in the use of quantum sensors for single photon detection – original work funded by Laboratory Directed R&D program at Fermilab (PI Aaron Chou).
- Later extended to make use of superconducting cavities, work partly funded within SQMS.

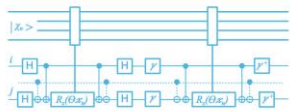
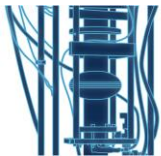
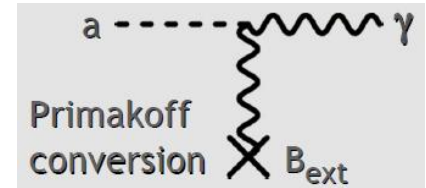

Quantum Metrology Fridge

- Oxford Instruments Triton XL fridge platform with 470 mm diameter mixing chamber plate.
- Incorporates a 14 T / 90 mm bore cancelled NbTi magnet at 4-K

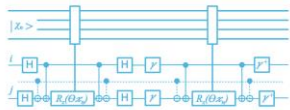
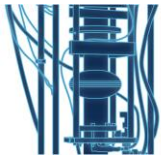
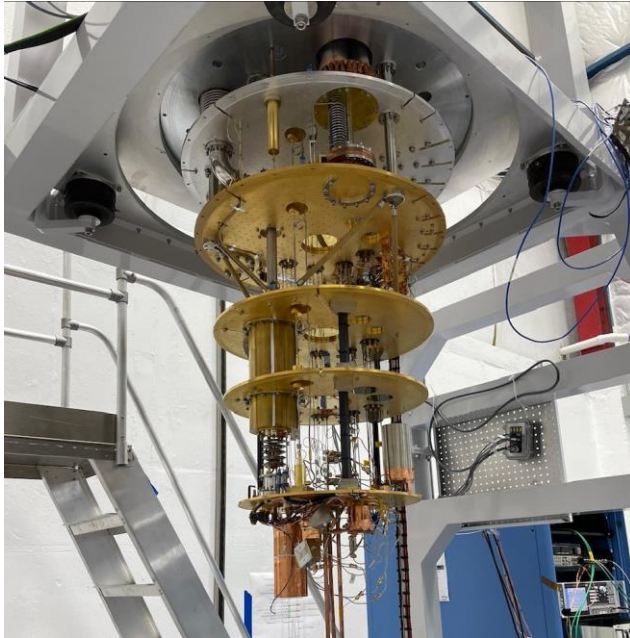

SQMS “DR8”

- An additional fridge acquired from Bluefors at the same time as the five fridges in the Quantum Garage will include an 9 T / 152 mm bore magnet
- Fridge is otherwise identical to DR3-DR7 in the Garage, but will be installed at grade level in the adjacent Heavy Assembly Building (which also houses the Colossus cryostat)

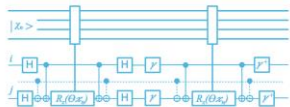
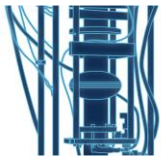
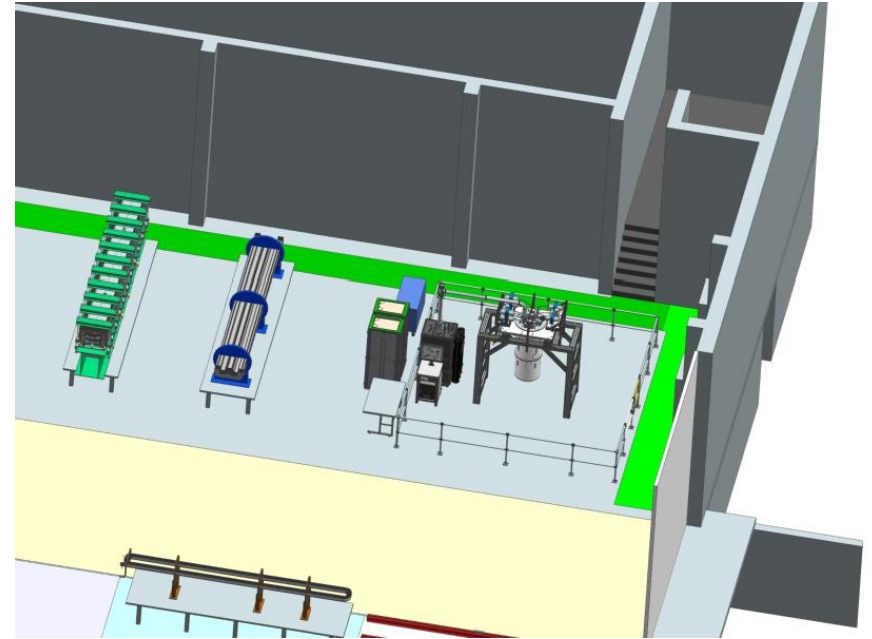

Axion Dark Matter Experiment – Extended Frequency Range (ADMX-EFR)

- Pushing the ADMX experiment to higher frequencies requires higher fields and/or larger volumes than currently available in the UWashington
- Fermilab is in the process of acquiring a surplus experimental MRI magnet from University of Illinois that provides a 9.4 T field in an 800 mm room temperature bore, with the intention of using the magnet as the basis of a high-frequency experiment, currently being funded for R&D under the DOE Dark Matter New Initiatives program
- The experiment would couple two high-power dilution refrigerators to the magnet, with one cooling the experimental payload while a second fridge cools superconducting electronics outside of the shielded space

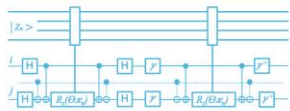
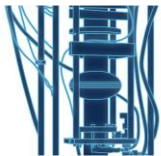

Axion Dark Matter Experiment – Extended Frequency Range (ADMX-EFR)

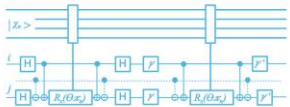
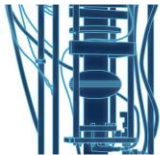
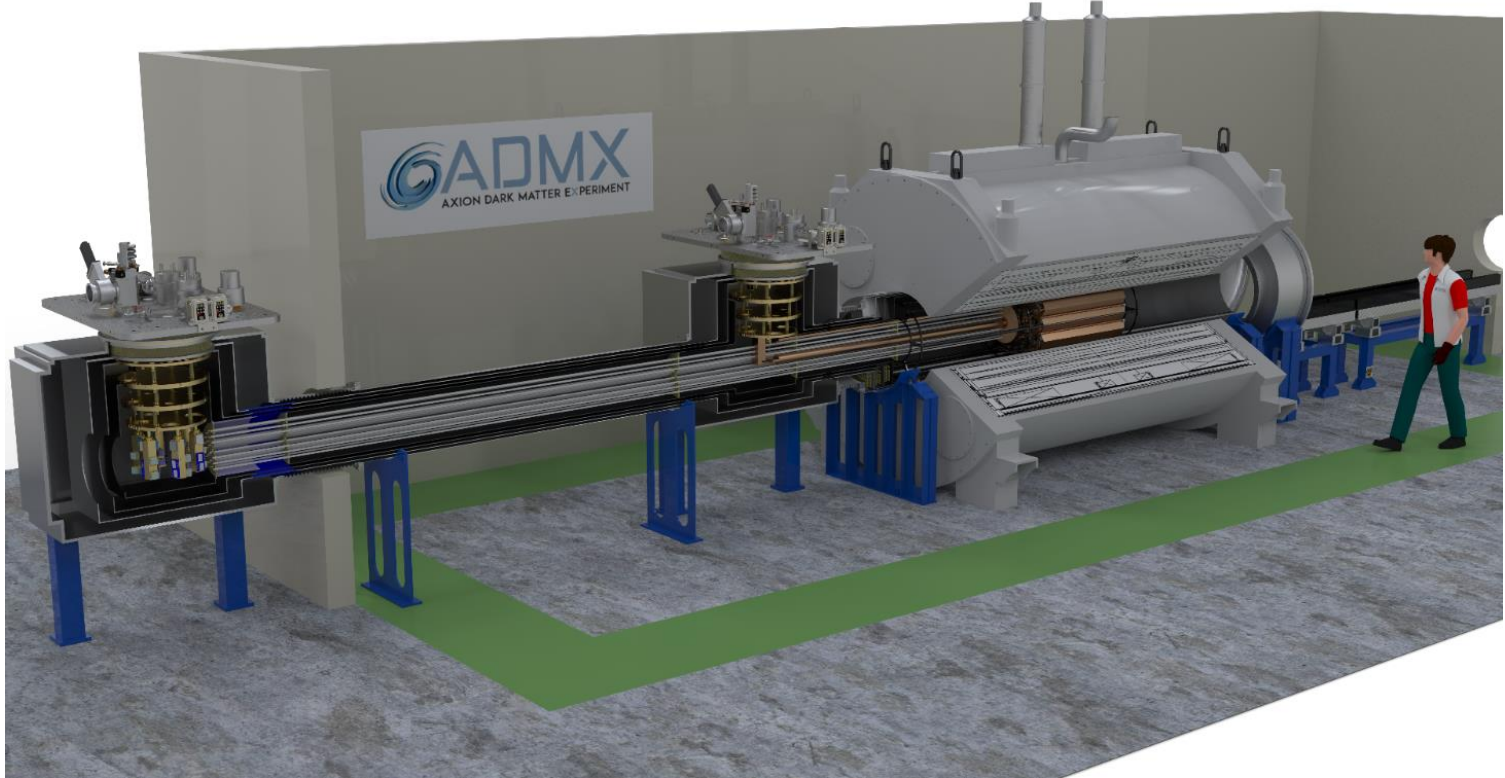

Axion Dark Matter Experiment – Extended Frequency Range (ADMX-EFR)

Plans to install the ADMX-EFR experiment as part of a larger “Dark Wave” Laboratory at Fermilab in the PW8 experimental hall, hosting multiple experiment and R&D programs

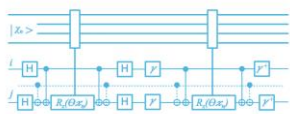
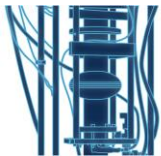
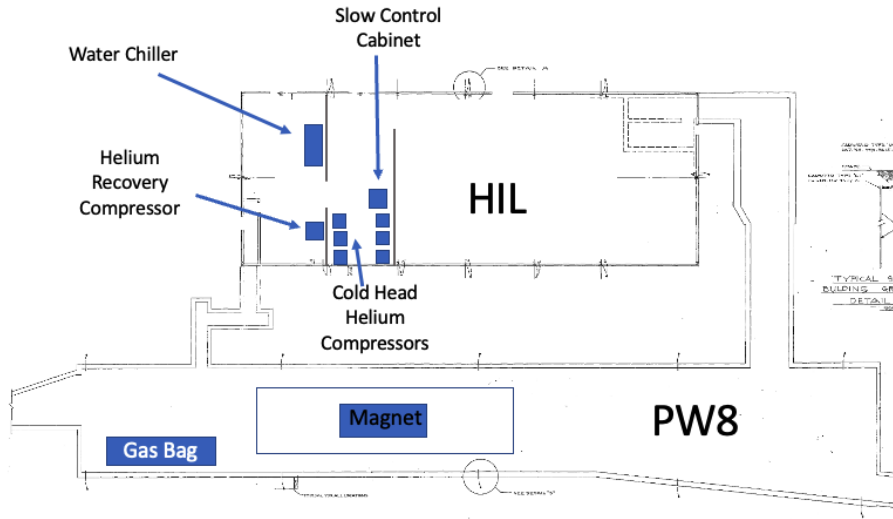

Underground / Low Background Lab at Fermilab

- Located in the MINOS hall at Fermilab
 - 100 m (225 mwe) underground for cosmic radiation shielding
 - Easy access

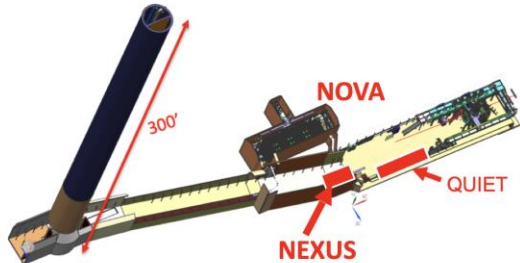

Muon rate is $3.4/\text{cm}^2/\text{day}$, compared to $1440/\text{cm}^2/\text{day}$ at the surface

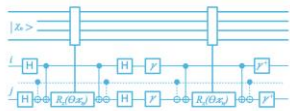
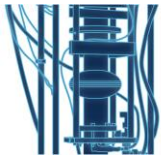

Quantum Underground Instrumentation Experimental Testbed (QUIET)

This QSC facility is the first low-background underground cryostat dedicated to superconducting qubit operation in the USA

- Oxford Instruments Proteox
- 250 ft² Class 10,000 clean room
- 50 ft² antechamber for gowning and material cleaning
- Initial fridge test reached 8.9mK

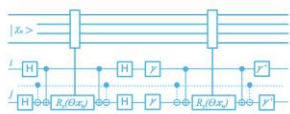
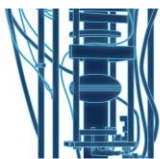

Matching Surface Test Stand - Loud

- In addition to the QUIET underground facility, there is an accompanying surface test stand.
- Nominally identical to the underground fridge, it is intended to allow for A-B comparison of devices.
- Both test stands are equipped with multiple RF channels (~12 per fridge) with extensive characterization equipment.
- Extensive use of QICK readout architecture.

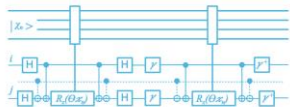
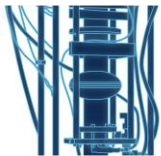

NEXUS Cryostat

- Customized CryoConcept HEXADRY fridge incorporating their isolated pulse tube technology
- Originally intended for calibration of detectors for high-mass dark matter with DC readout, the fridge was subsequently modified for RF payloads

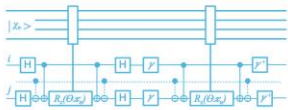
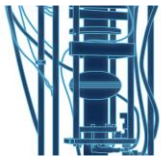
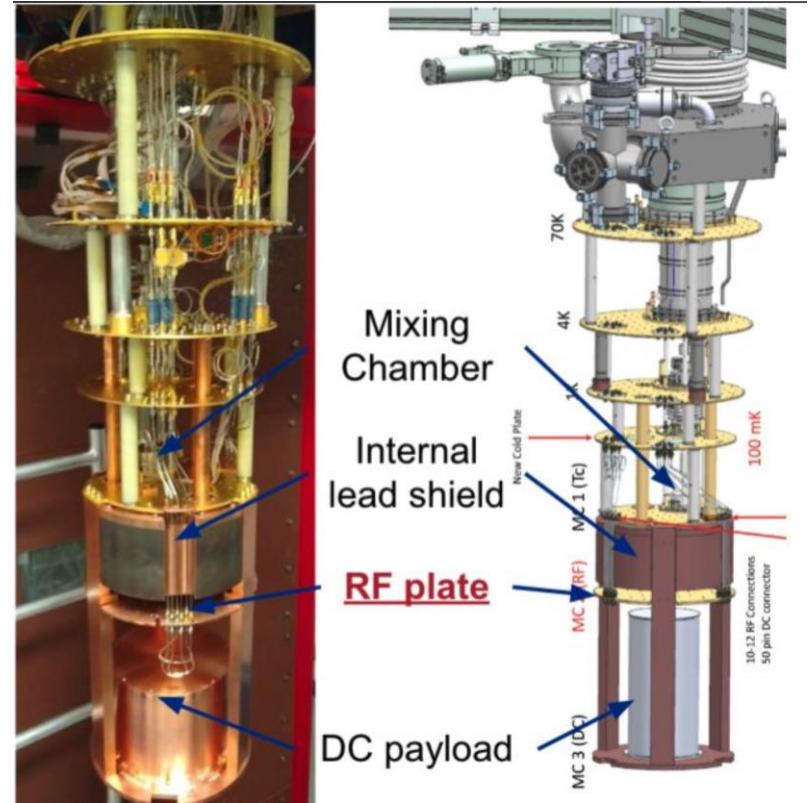

Northwestern Experimental Underground Site (NEXUS)

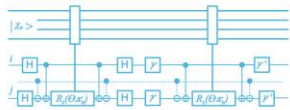
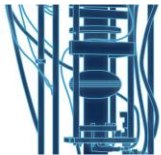
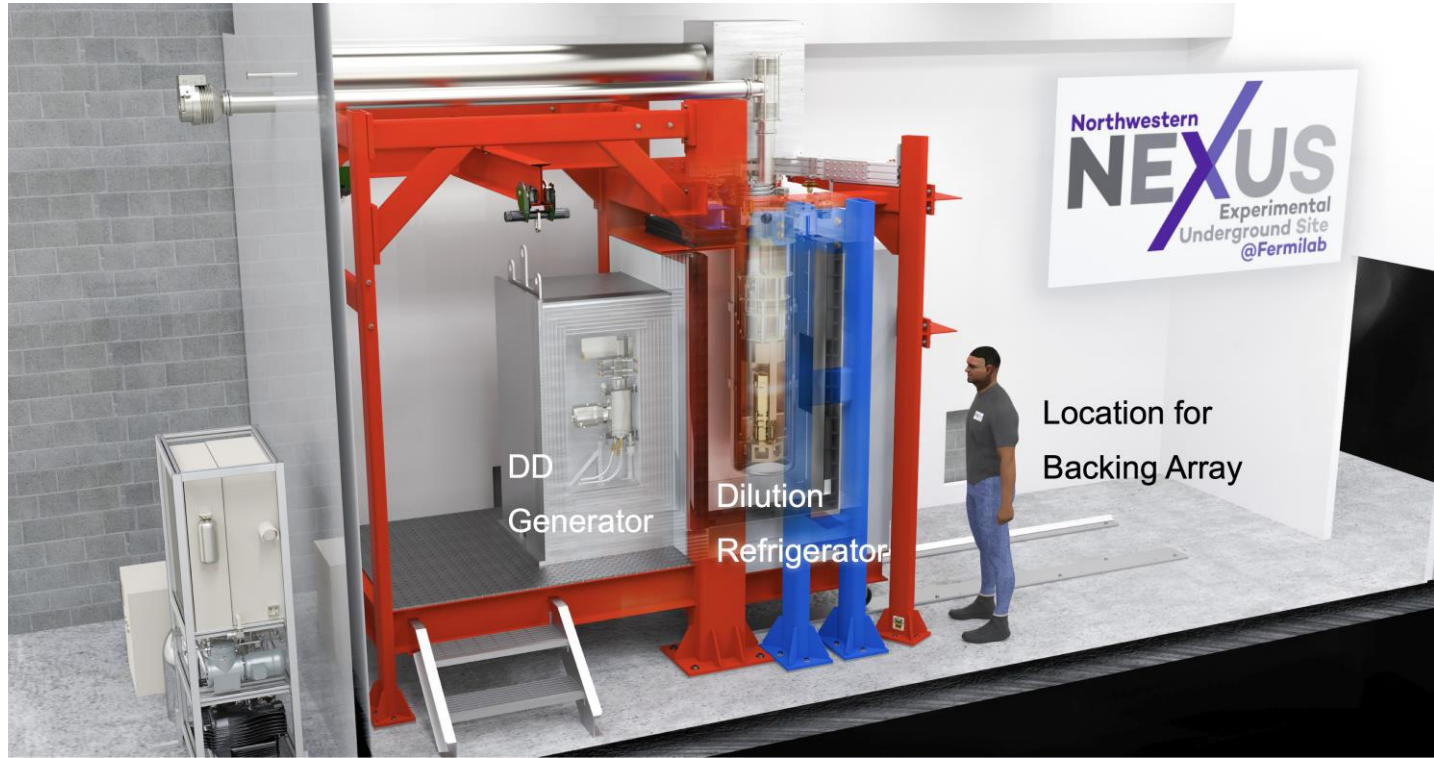

NEXUS Cryostat – Lead Shielding



- NEXUS incorporates a 4p lead shield, primarily outside the cryostat (right)
- Additional cast lead plug inside the cryostat between the experimental volume and the mixing chamber plate, sunk to the still plate.
- Reduces backgrounds by x100

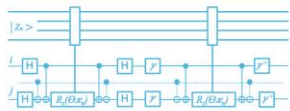
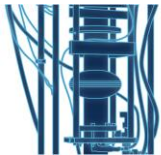

Summary

- This presentation has reviewed the currently available mK cryogenic test stands at SQMS and Fermilab more broadly, particularly focusing on the underground and low radioactive background facilities in the MINOS cavern.
- Currently, 11 dilution refrigerator test stands are operating in QIS-related areas.
- Relevant future facilities were also discussed, including Colossus and the proposed Dark Wave Lab / ADMX-EFR experiment

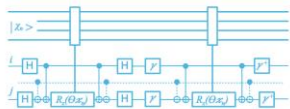
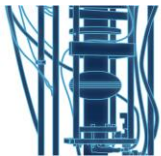

Upcoming Workshops at Fermilab

Dark Wave Laboratory (April 15-17)

Discuss plans for creating a shared facility for axion research, including experiments and collaborations that would benefit from shared cryogenic and magnet infrastructure.

Radiation Impact on Superconducting Qubits, RISQ (May 30-31)

Bringing together the broader QIS and particle physics communities to assess the effects of radiation and cosmic rays on superconducting solid-state qubits.

Both events appear on Indico, and members of the Organizing Committees are at this meeting.

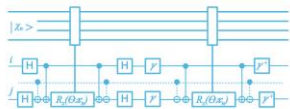
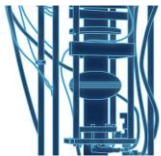

Acknowledgement

This material is based upon work supported by the U.S. Department of Energy, Office of Science, National Quantum Information Science Research Centers, Superconducting Quantum Materials and Systems Center (SQMS) under contract number DE-AC02-07CH11359

