

2024/03/20

SNOLAB Facility Overview

Andy Kubik

Research Scientist @ SNOLAB

Adjunct Prof. @ U. of Toronto





Introducing SNOLAB

SNOLAB hosts rare event searches and measurements. It's located 2 km underground in the active Vale Creighton nickel mine near Sudbury, Ontario, Canada.

SNOLAB is operated jointly by University of Alberta, Carleton University, Laurentian University, University of Montreal, and Queen's University.

SNOLAB operations are funded by the Province of Ontario, and the Canada Foundation for Innovation.

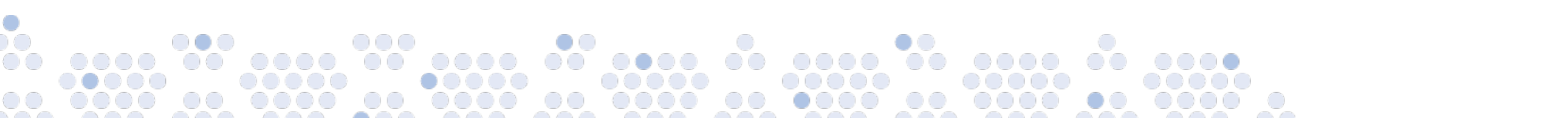

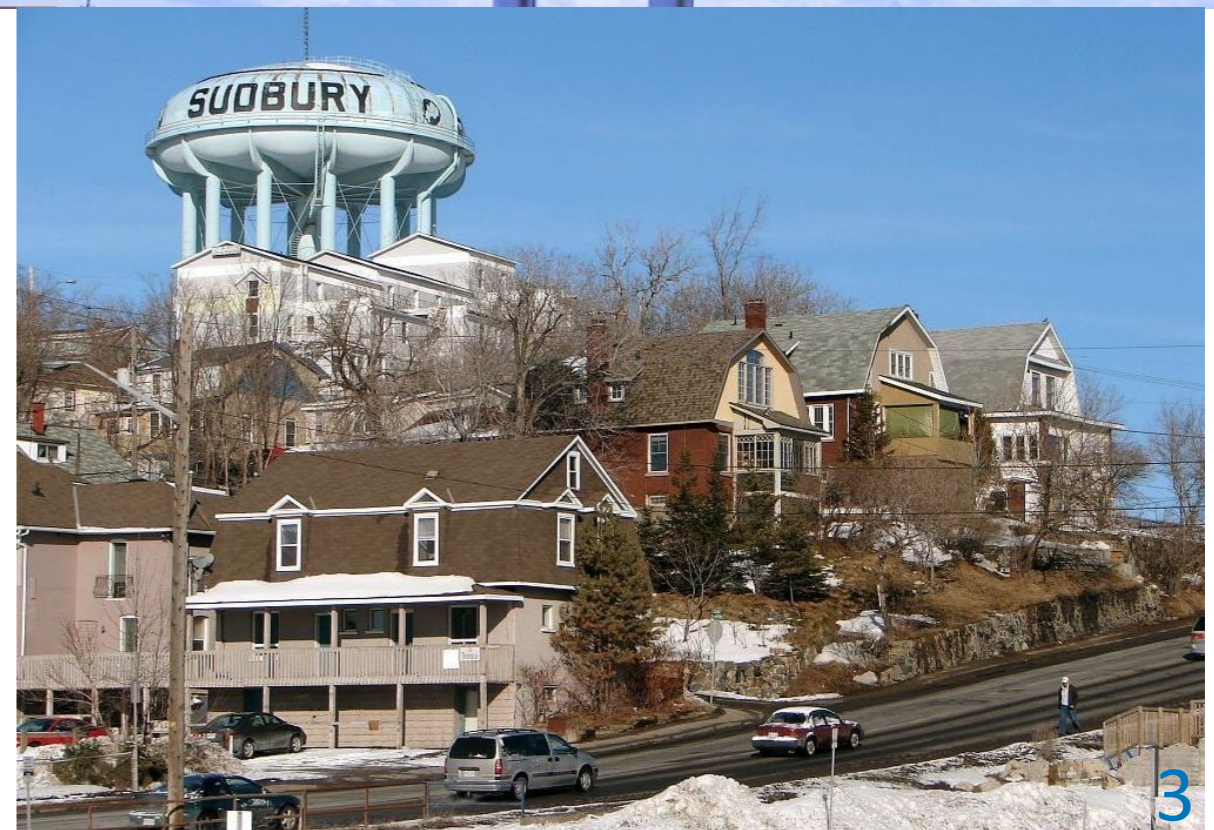

SNOLAB

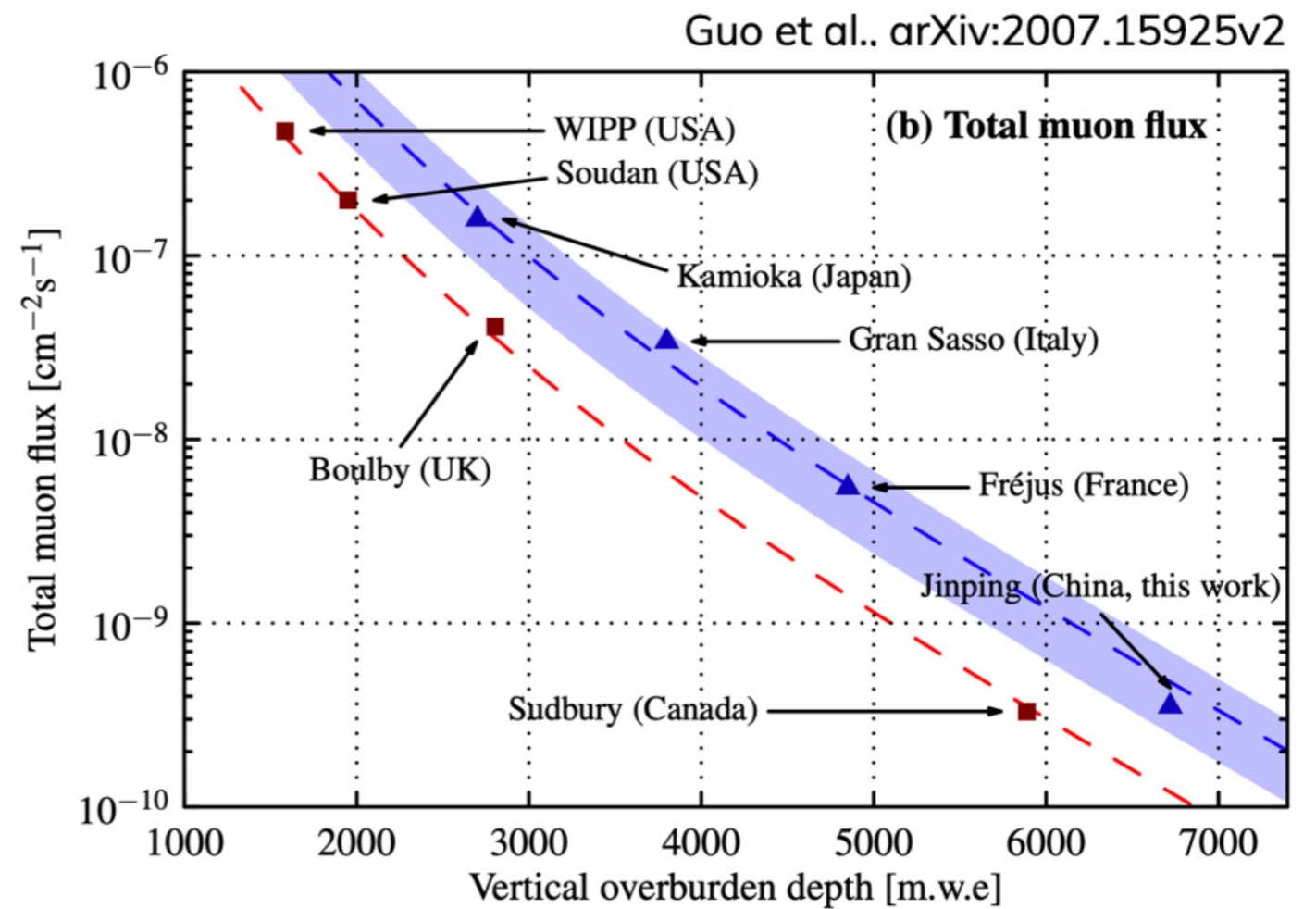

Science Strategy

The science at SNOLAB is focused on increasing our understanding of the particles and forces that have shaped the universe.

- What is the nature of dark matter?
- What is the nature of the neutrino?

SNOLAB collaborates with scientific research requiring deep underground facilities.

- Neutrino observatories (solar, supernovae, geo, reactor, etc.)
- Effects of radiation on biological systems
- Environmental monitoring (nuclear non-proliferation, aquifers, etc.)

SNOLAB is interested in pursuing new collaborations and opportunities in emerging areas of underground science

- Effects of radiation on quantum technologies



The Sudbury Neutrino Observatory

Nobel Prize in Physics 2015: Takaaki Kajita & Arthur B. McDonald

2016 Breakthrough Prize in Fundamental Physics:
Arthur B. McDonald and the SNO collaboration

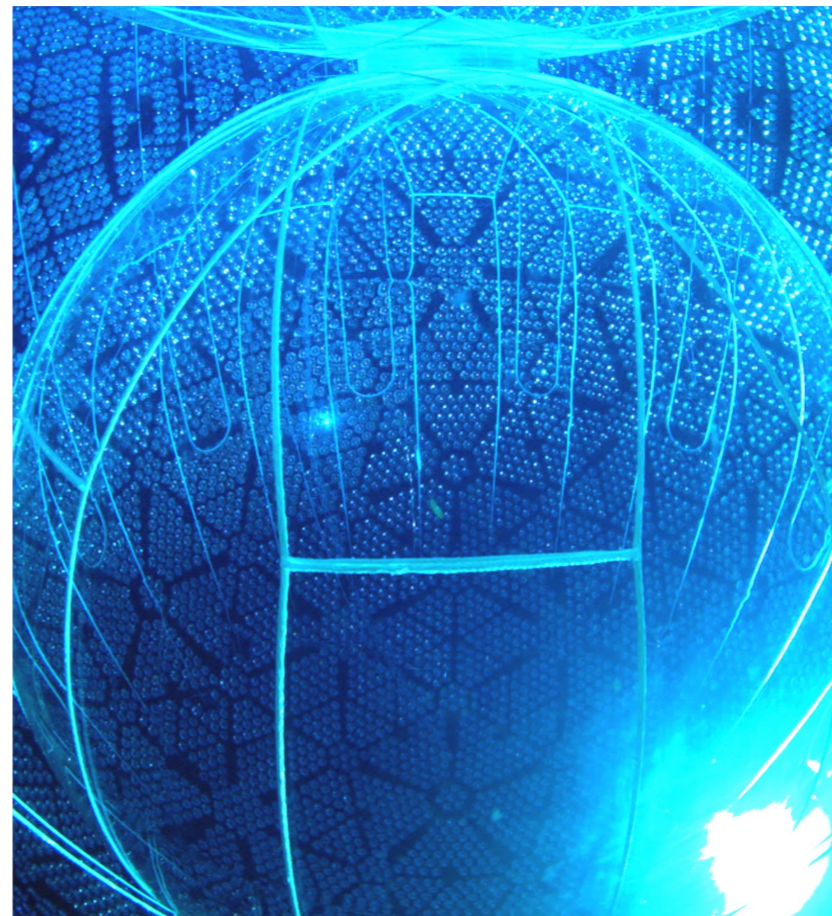
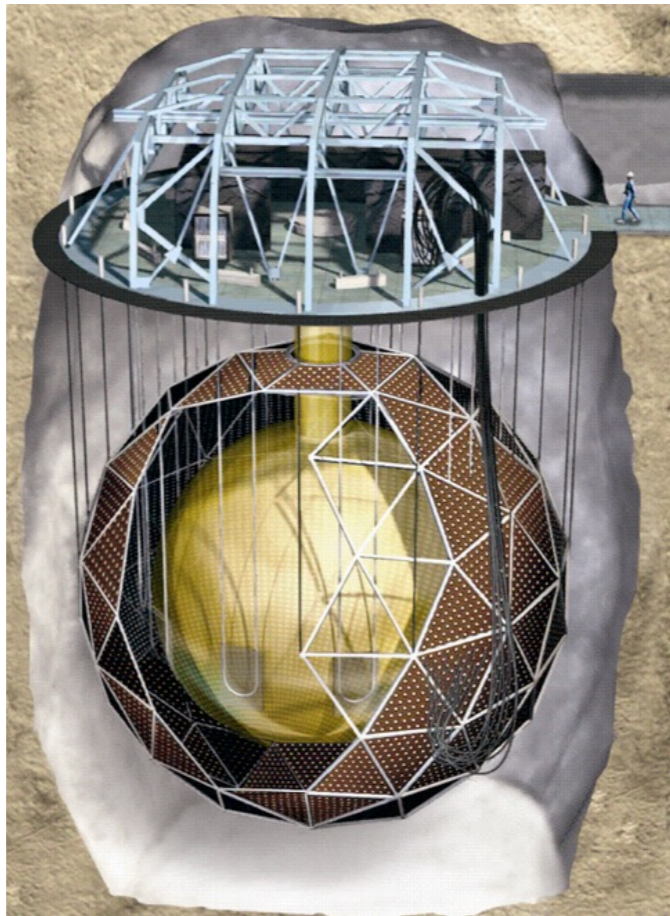

Infrastructure: Surface Spaces & Support

Offices, Clean Labs, Shipping/Receiving on Surface

- Dedicated office space for users.
- Clean room laboratories for surface work and final checks before shipping underground.
- Chemistry, fume hoods, ICP-MS, lots of material etching to remove surface contamination, etc.
- Multiple meeting rooms (10-20 people) and auditorium seating 150.
- Full machine shop (CNC, water jet cutting, 3D printing, etc.)



SNOLAB Underground – at a Glance

Current Experiments
Future Experiments
Laboratory Facilities
Experiment Areas

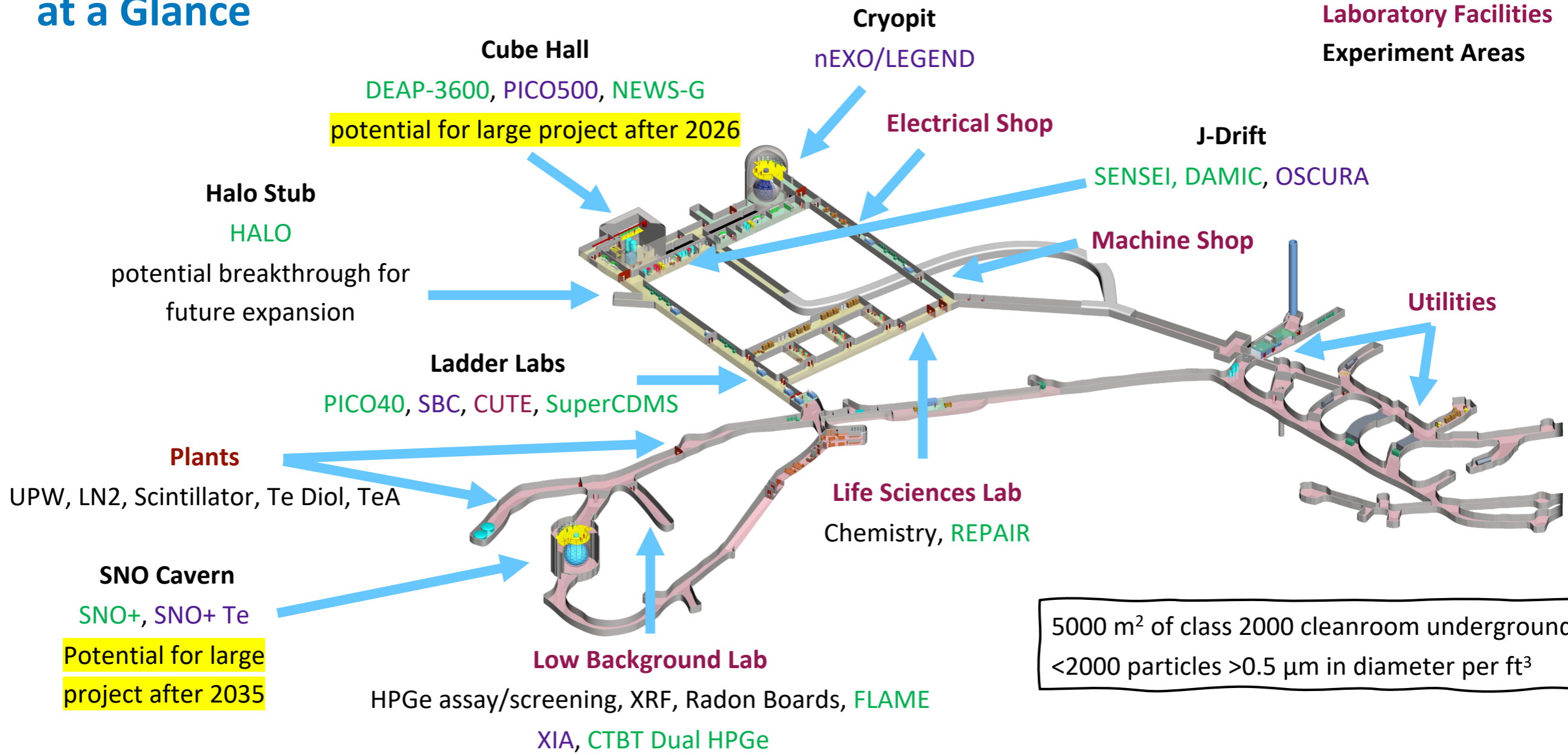

5000 m² of class 2000 cleanroom underground.
<2000 particles >0.5 μm in diameter per ft³



Infrastructure: Underground Facilities

Besides experiments, SNOLAB has multiple facilities to support projects underground.

Lunchroom (refuge)

- Full break room, microwaves, fridges, meeting room
- Deepest working restrooms (flushing toilets) in the world thanks to our underground sewage treatment plant

Liquid Nitrogen Plant

- Low radon liquid nitrogen plant underground.
- Capacity to supply all necessary LN to users

Ultra-pure Water (UPW) plant

- Originally built to support SNO facility, now supplies entire lab with UPW for various uses

Chemistry Lab with fume hood

Machine shop

Gaseous Nitrogen Plant

Several Low Radon clean rooms



Low Background Counting Facility

Provides material screening for SNOLAB projects and also the wider community (including industry)

Gamma Counting

- Ultra-pure Ge detectors (5 different detectors with different sensitive ranges, etc)
- PGT Coaxial Detector (PGT), Canberra Coaxial Detector (Lively), Canberra Well Detector, Eurisys Mesures Coaxial Detector (Vue Des Aples), Canberra Coaxial Detector (Gopher)

Alpha Counting

- XIA UltraLo-1800 alpha counter
- Maximum sample weight: 9kg
Maximum sample thickness: 6.3mm

Radon Emanation

- Provide Radon emanation study of all construction materials
- *Electrostatic Counter(ESC) and Liquid Nitrogen Cooled Traps + Lucas Cell*

<https://www.snolab.ca/users/services/gamma-assay/services.html>

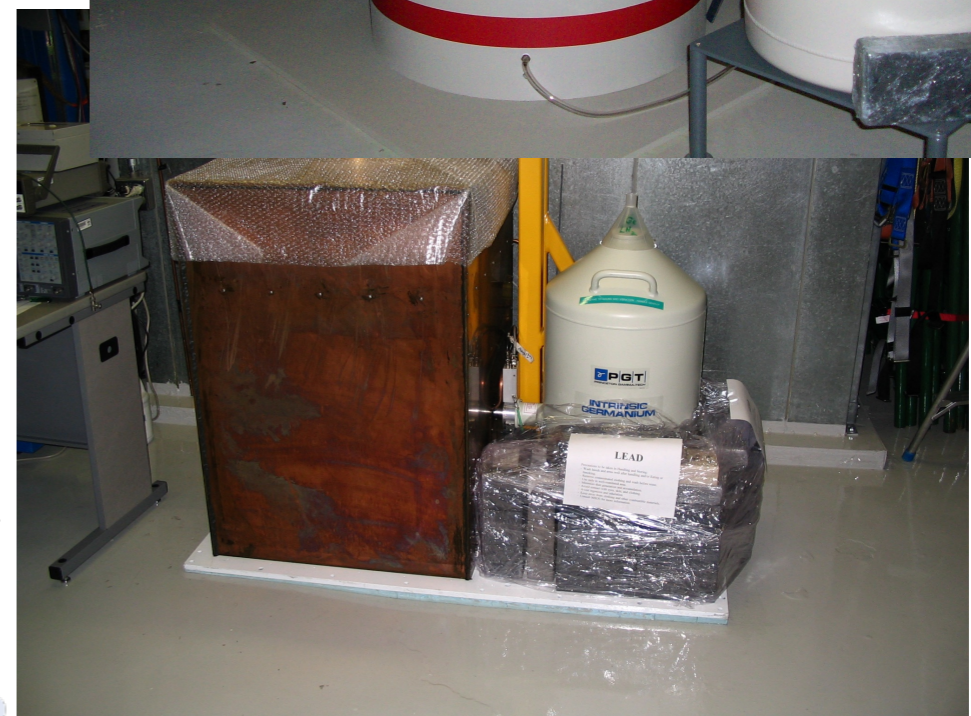

Cryogenic **U**nderground **T**est Facility (CUTE)

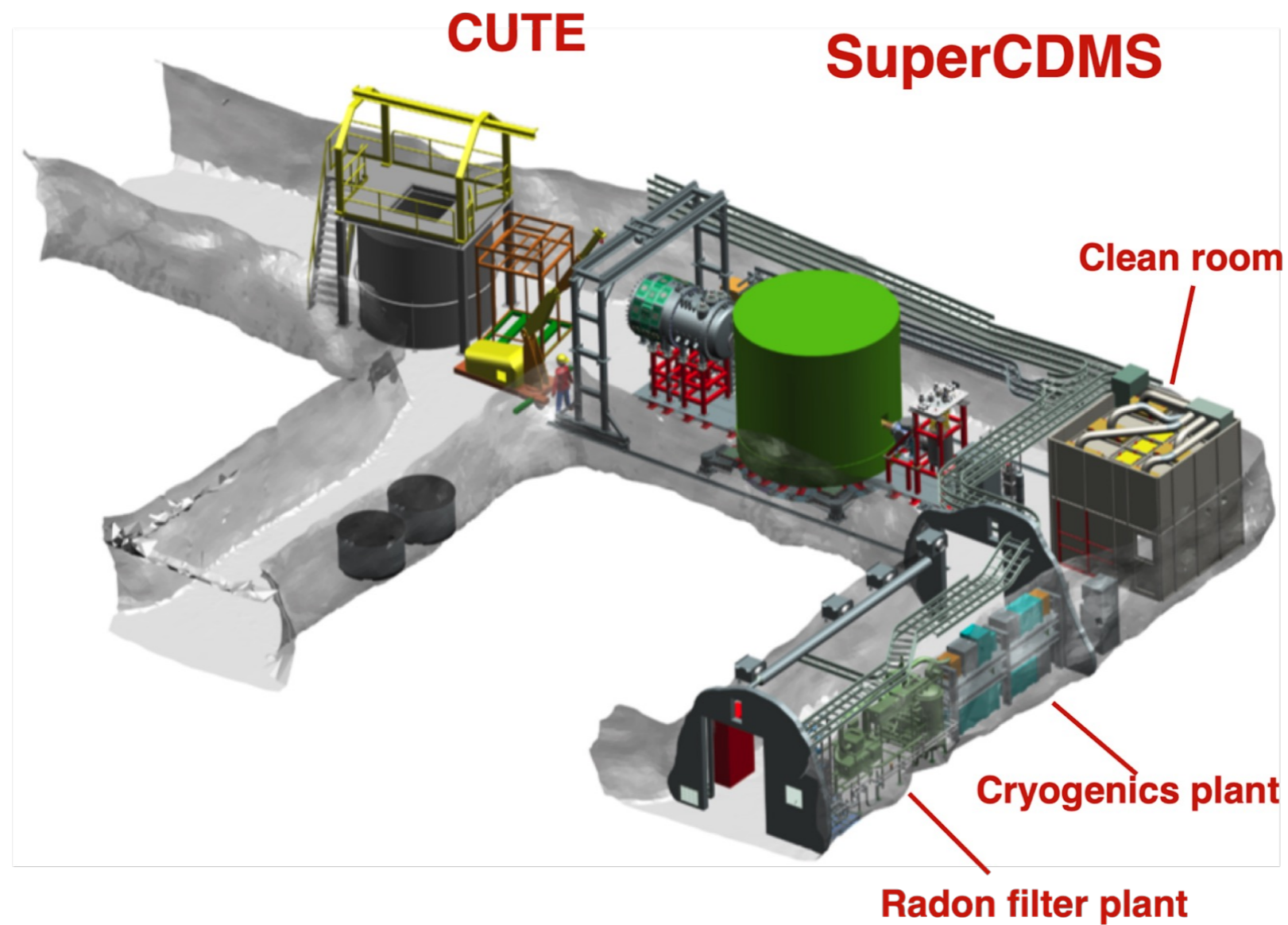

TEst Facility Overview

What the CUTE Facility can offer:

- Operational temperature as low as **12 mK**
- Low overall radioactive background
- Minimal mechanical vibrations thanks to cryostat suspension system
- Low level of electromagnetic interference
- Availability of calibration sources (gamma, neutron)
- Full remote operations
- Low-radon, class 300 cleanroom to change payload
 - Typical Rn level $< 15 \text{ mBq/m}^3$

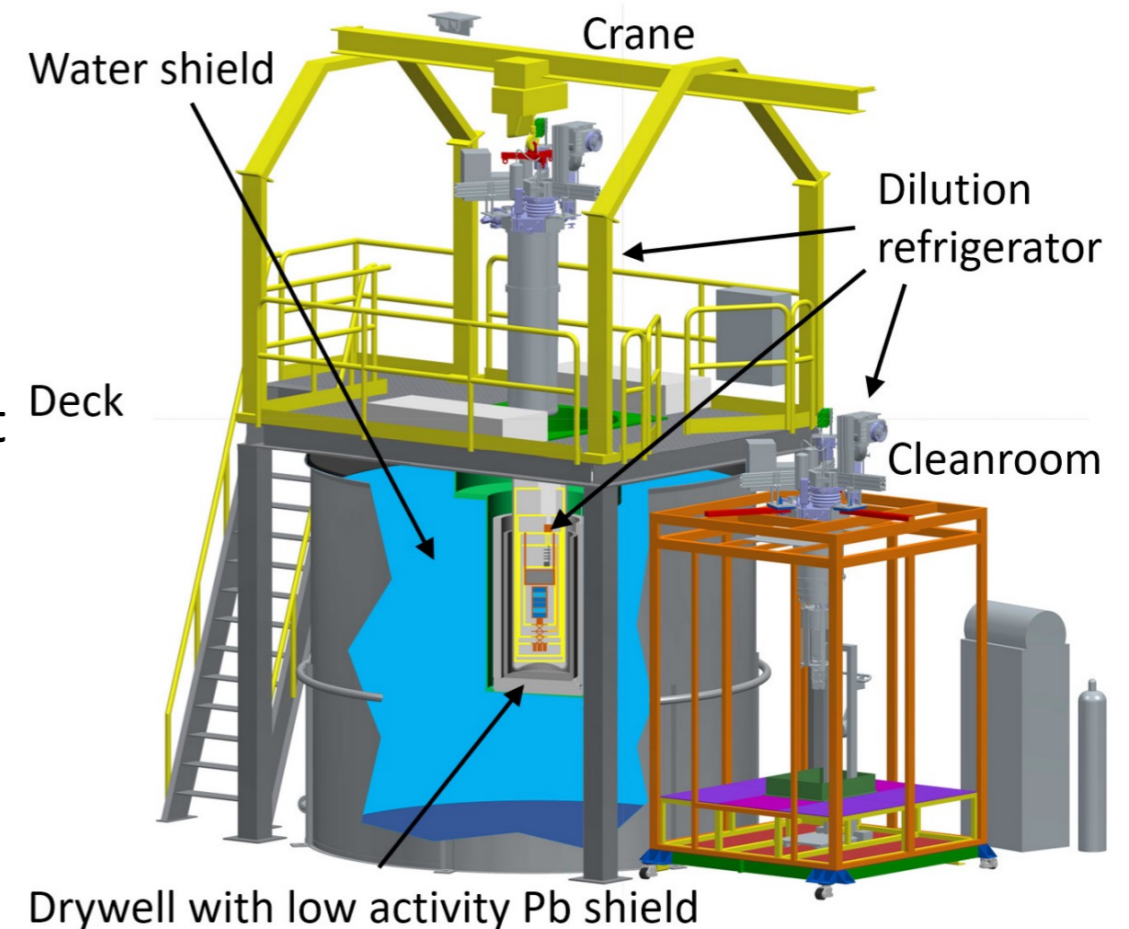

Cryogenic

Dilution Fridge:

- Base temperature ~ **12 mK** with payload
- Cooldown time ~ 3 ½ days, largely driven by ~100 kg internal Pb shielding
- Fridge can run unattended for extended periods, critical in the underground environment
 - New Liquid Nitrogen refill system allows for continuous running for ~ 2 months

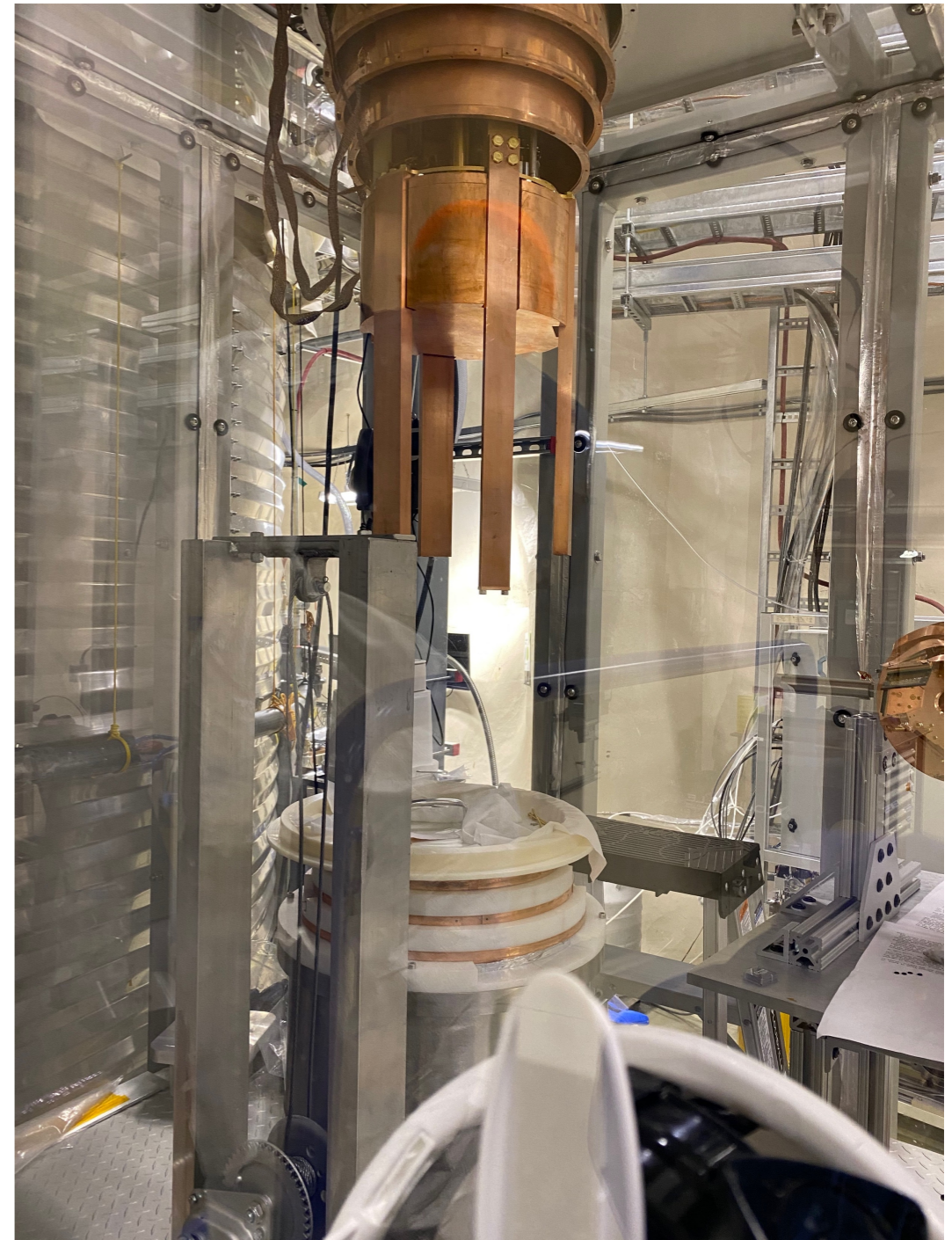

Shielding and Backgrounds

Shielding:

- ~ 10 cm low activity Lead in drywell
- Mu-metal reduces external B-field by $\sim x50$
- ~1.5 meter of water and 20 cm Polyethylene lid
- 15 cm Lead “plug” inside of cryostat
- Active low radon air purge in drywell

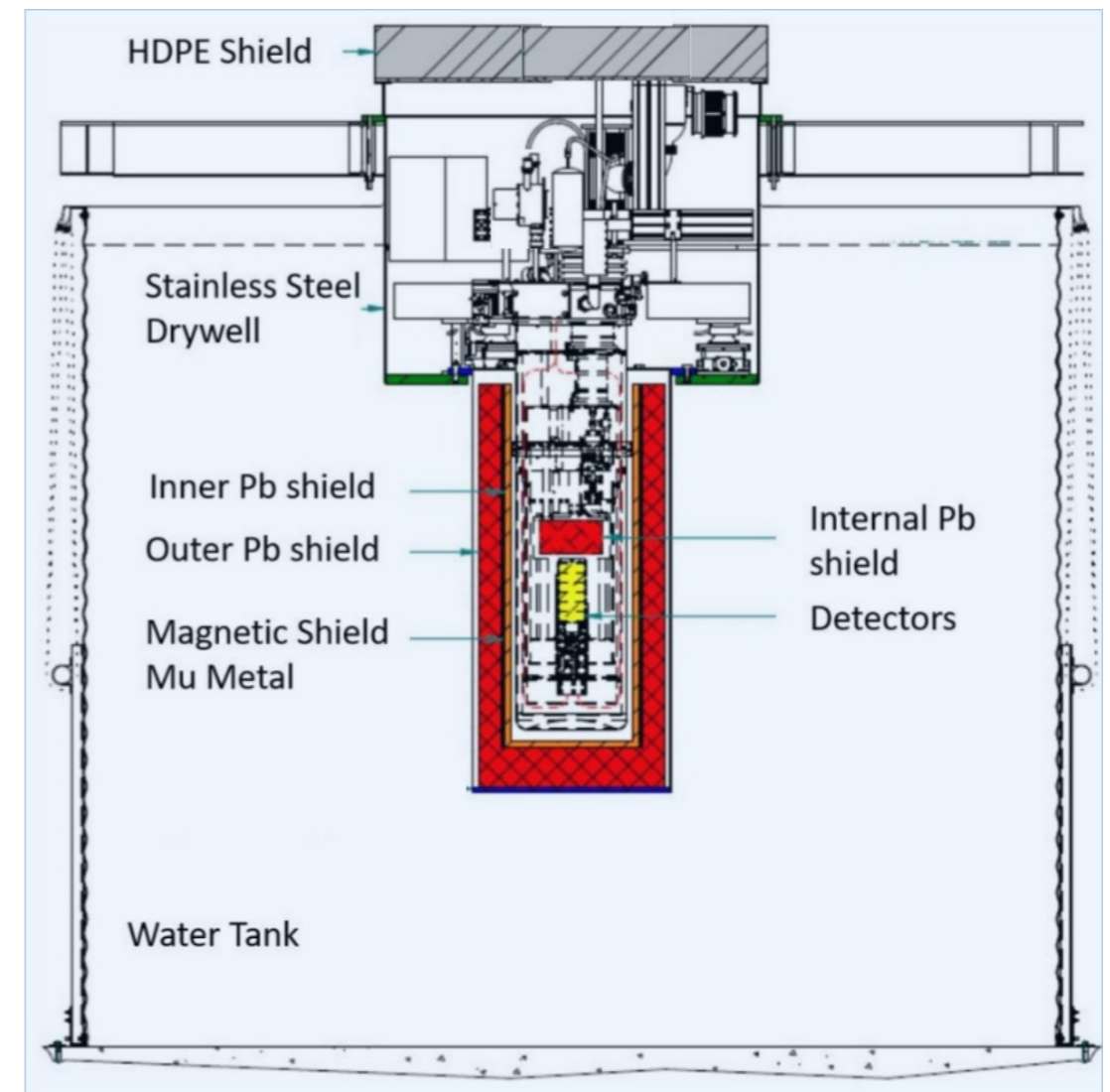

Backgrounds

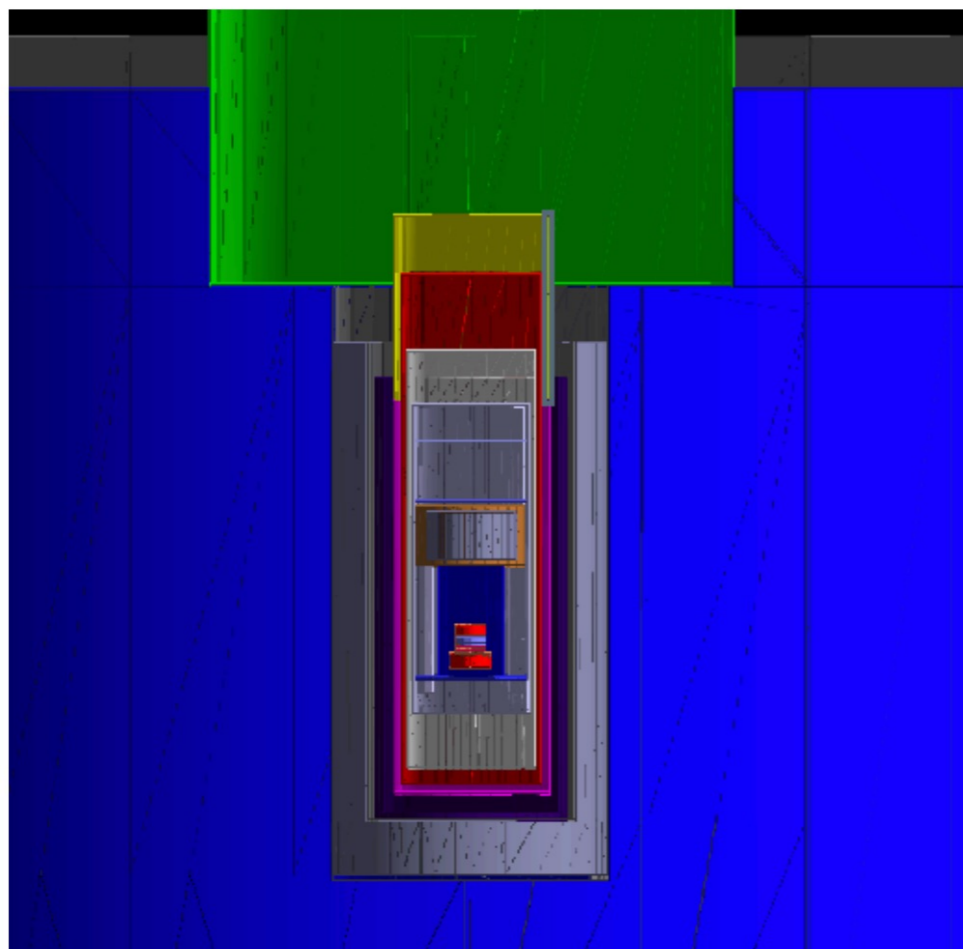

Geant4 visualization of the CUTE geometry

Backgrounds:

- Shielding and clean underground environment lead to low backgrounds
- All materials screened for activity using HPGe background counting facility at SNOLAB
- Create a full bill of materials in the facility
- Along with a detailed GEANT4 simulation, propagate background for each contaminate to <insert your favourite detector>
- Use Background Explore tool developed by B. Loer at PNNL to normalize contribution and generate expected event rate

Backgrounds Budget

M. Baiocchi and A. Pleava (SNOLAB)

Energy Spectra - By Component

PRELIMINARY

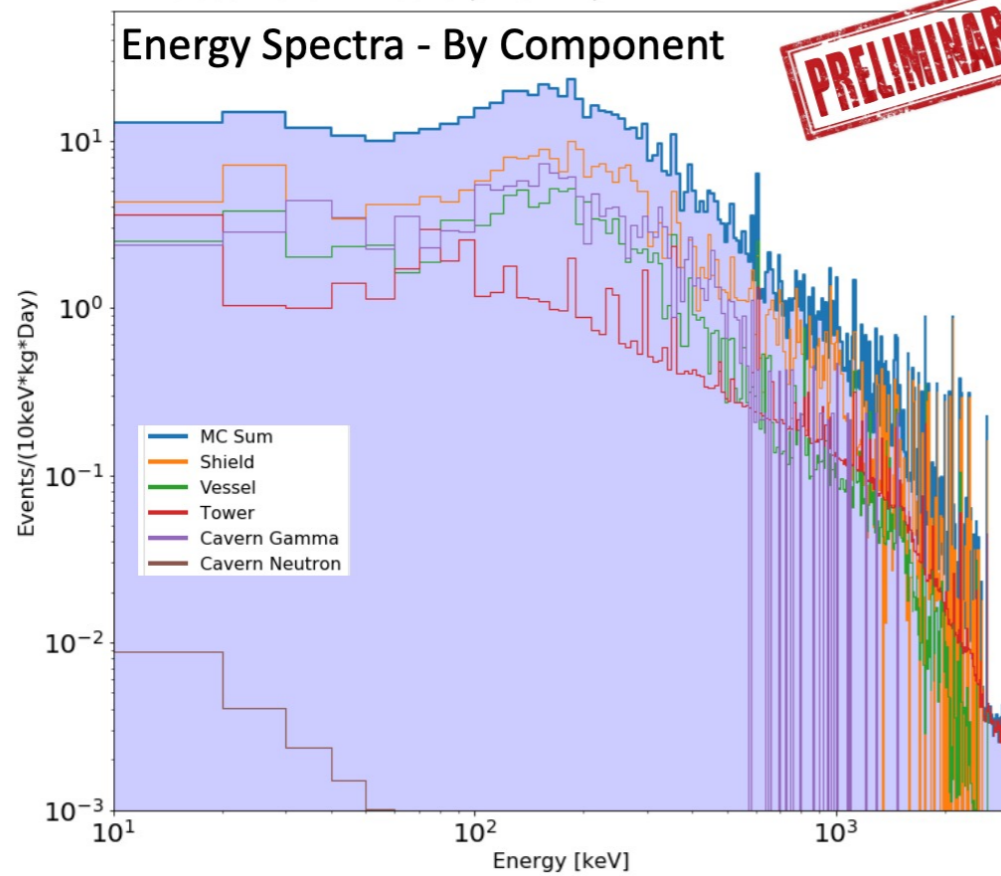

M. Baiocchi and A. Pleava (SNOLAB)

Energy Spectra - By Contaminant

PRELIMINARY

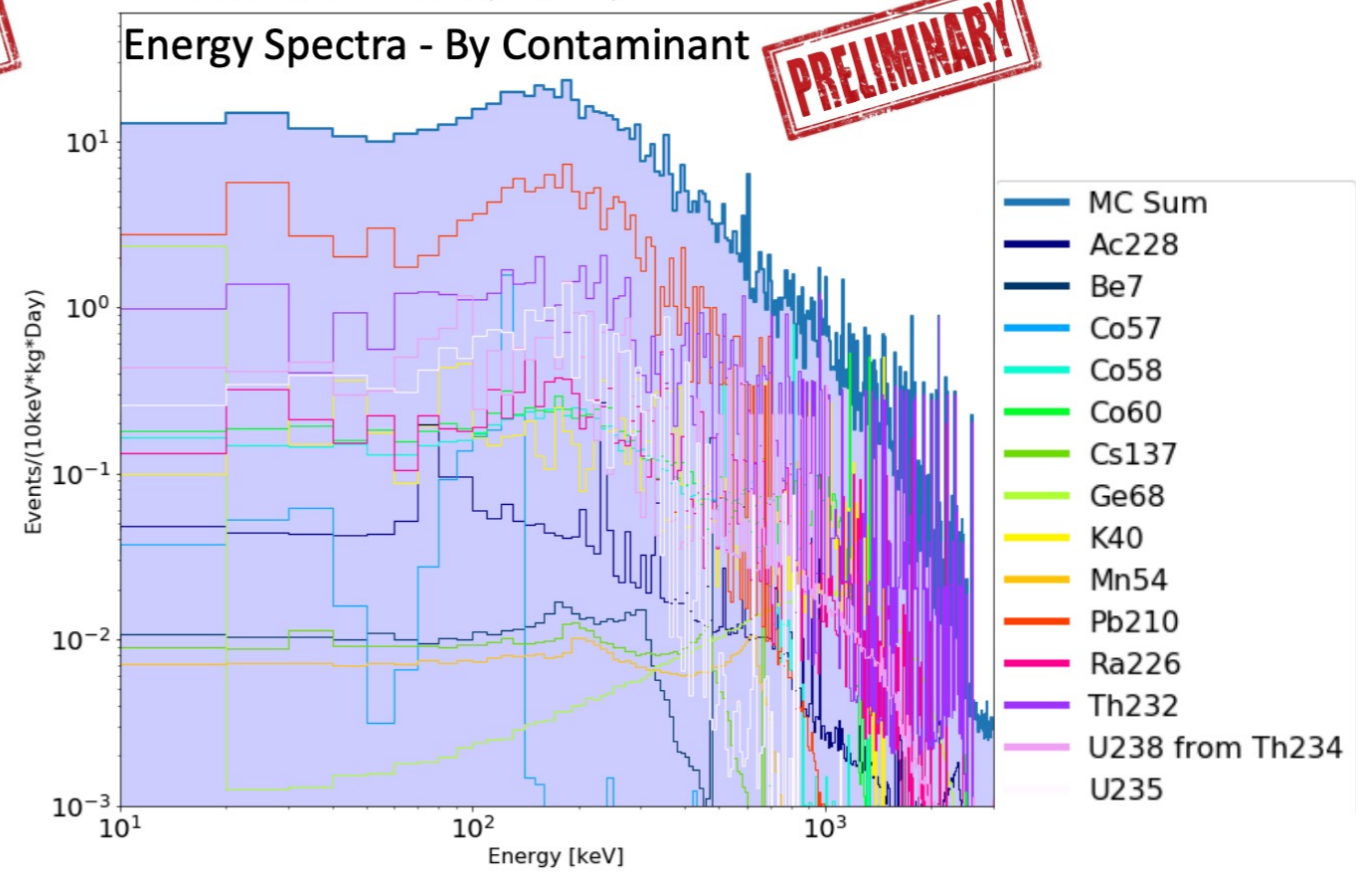

Backgrounds

M. Baiocchi and A. Pleava (SNOLAB)

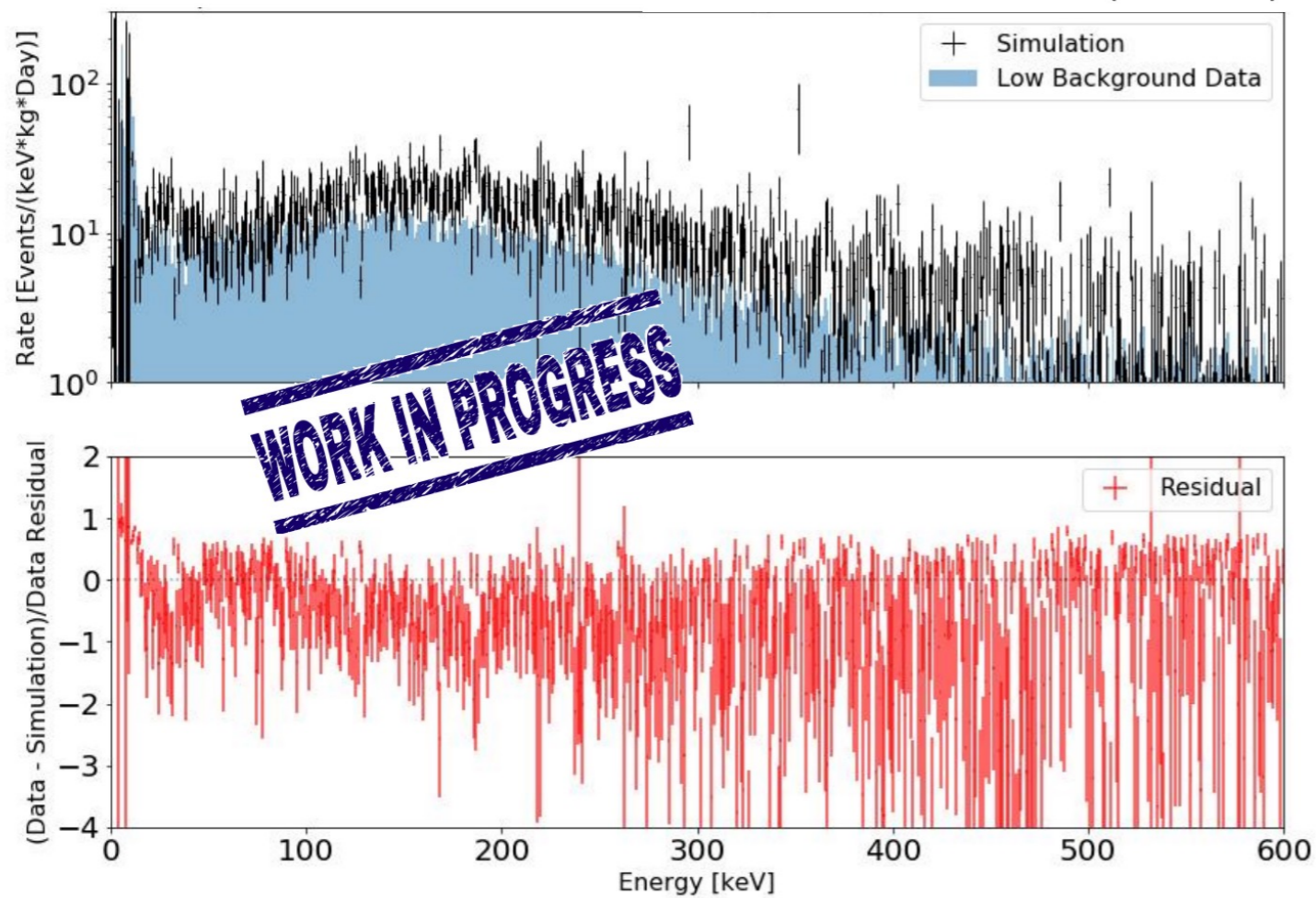

Backgrounds:

- Simulation validated with real data
- 600 g Ge detector
- Agreement is pretty good
- Rate from facility
 - 5.6 ± 0.6 evts/kg/keV/day [1-1000 keV]

Vibrational Isolation

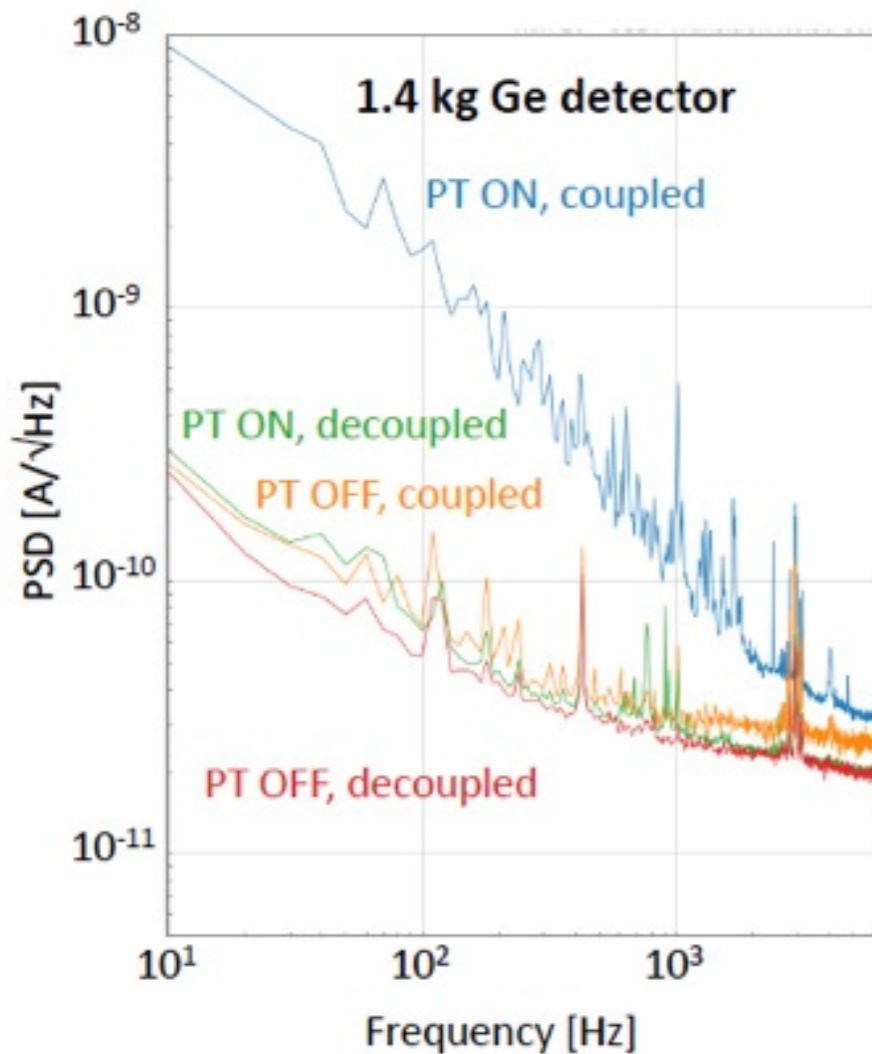

Vibrations:

- Suspension system decouples cryostat from pulse tube and environmental vibrations coupling in through the deck.
- We quantify the impact of vibrations with SuperCDMS detector
- Only marginal differences are seen in noise with suspension system active when we turn on and off the pulse tube cooler (one of our biggest sources of vibration)

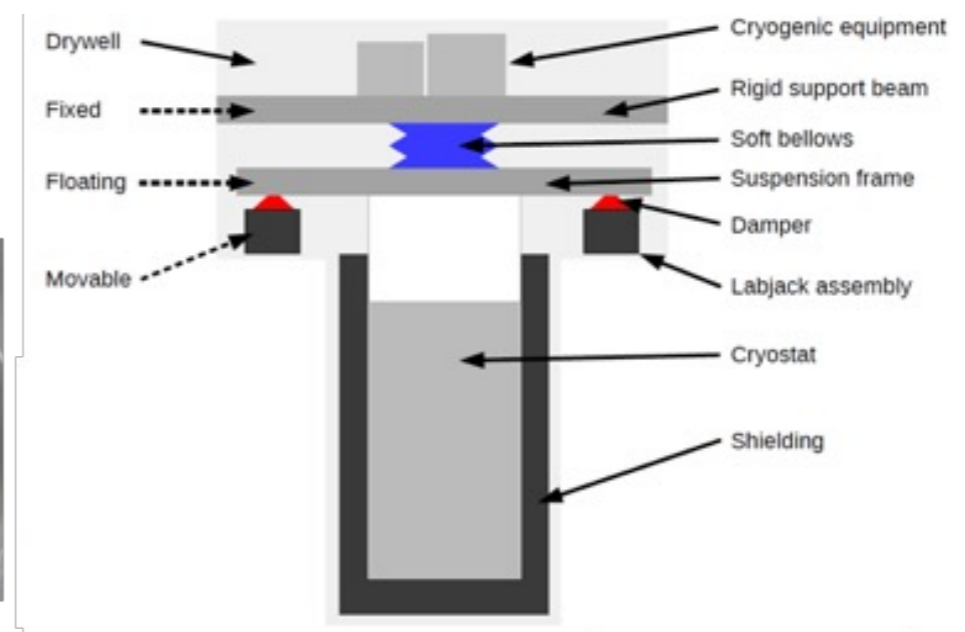
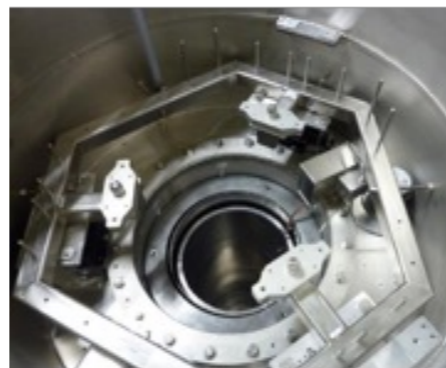

Dedicated Low Radon Clean Room



We keep it clean:

- All payload and fridge work done in our class 300 clean room (clean room inception!)
- Low radon air supplied from surface and passed through HEPA filters
- Typical radon levels $< 15 \text{ Bq/m}^3$, but more often $\sim 5 \text{ Bq/m}^3$ (depends on weather at surface)
- Now able to use SuperCDMS Radon Reduction system to further reduce radon to $< 1 \text{ Bq/m}^3$

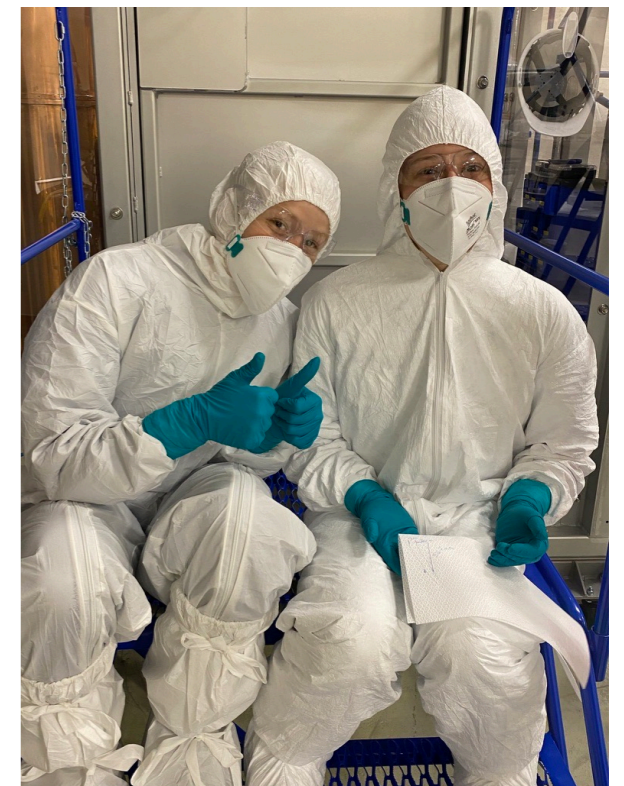

Near Term Plans

SNOLAB User Facility:

- **CUTE is a SNOLAB user facility!**
- SNOLAB-maintained and continuously improved
 - Collect proposals
 - Expert committee will make recommendations, CUTE management will negotiate details
 - Work with users to implement their experiment

Future Uses

- **Detector testing**
 - Future DM detectors (total mass of ~ 20 kg are possible)
 - Rare event searches (such as ^{50}V rare nuclear decay search)
 - HVeV devices
 - Single photon IR sensors (Nanowire)
 - **Testing effect of backgrounds on superconducting qubits**
 - <insert your idea here>

Interested?

*Have a project that would
benefit from running at
CUTE?*

Please let us know!

Qubits in CUTE

Funded proposal to study Qubits in a low radiation underground environment

- Funded by US Army Research Office
- Collaboration between SNOLAB, University of Waterloo, and Chalmers University of Technology
- Prof. Chris Wilson at the IQC is the project leader
- Chalmer's University will produce superconducting qubit arrays
- CUTE facility offers excellent opportunity to study ionization effects on coherence
- Upgrades to CUTE fridge to accommodate are funded and underway
- Similar upgrades for similar work on same fridge model at NEXUS (see photo)

This is NEXUS (same fridge model)
For Illustrative purposes only

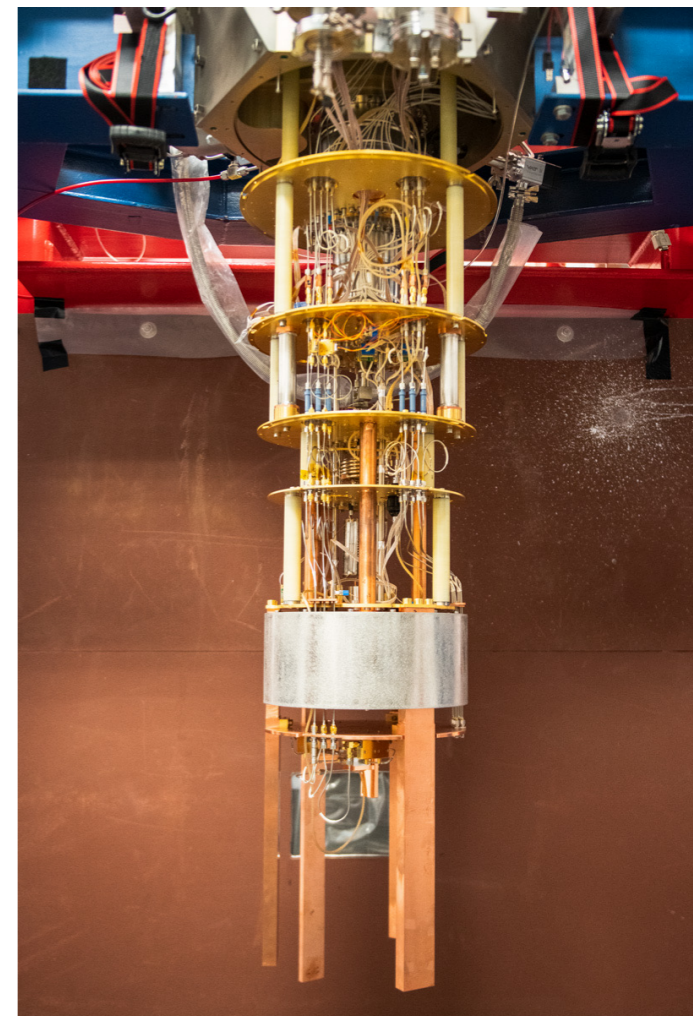

Thank You!

Backup

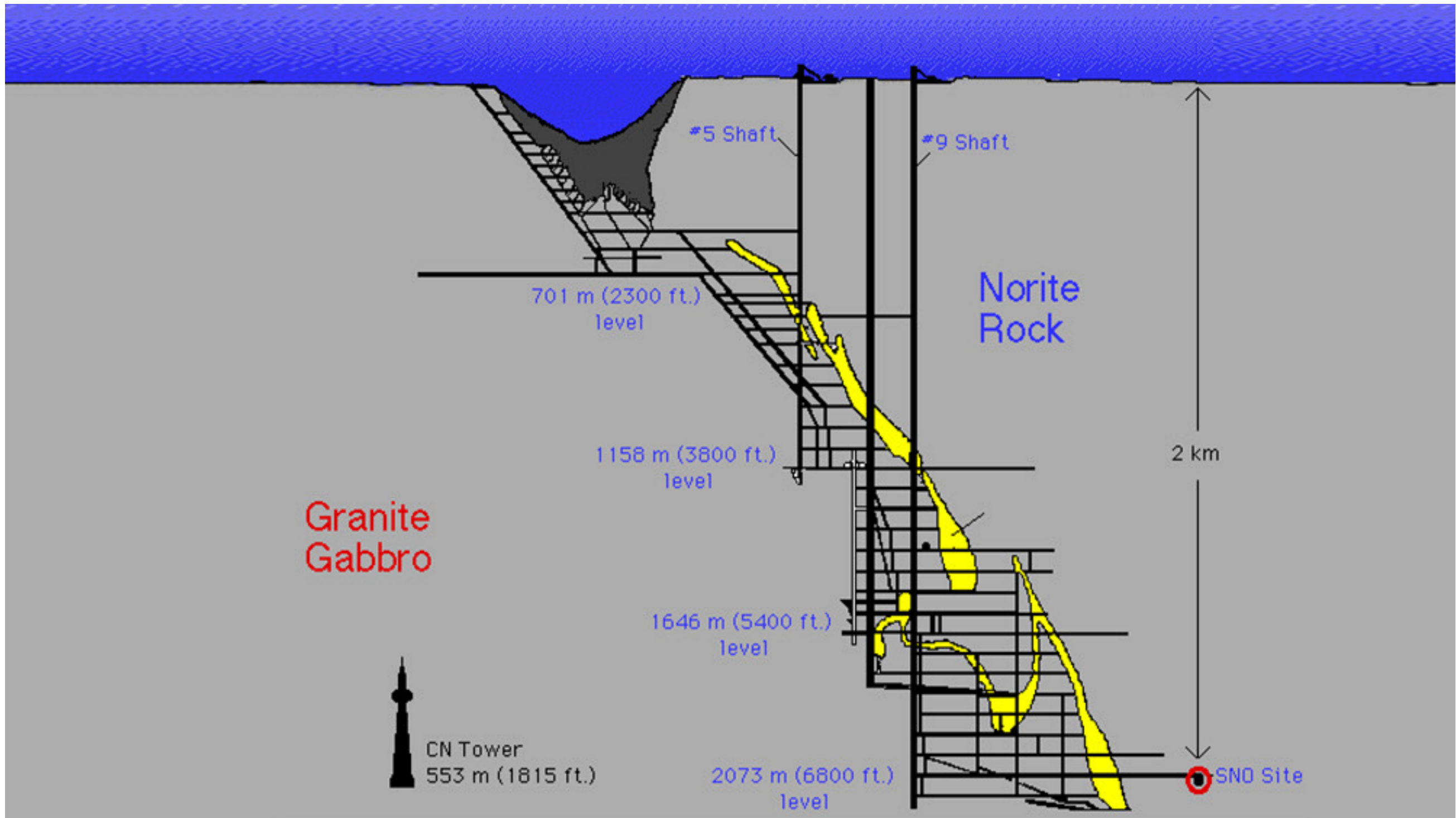

Dark Matter detectors at SNOLAB

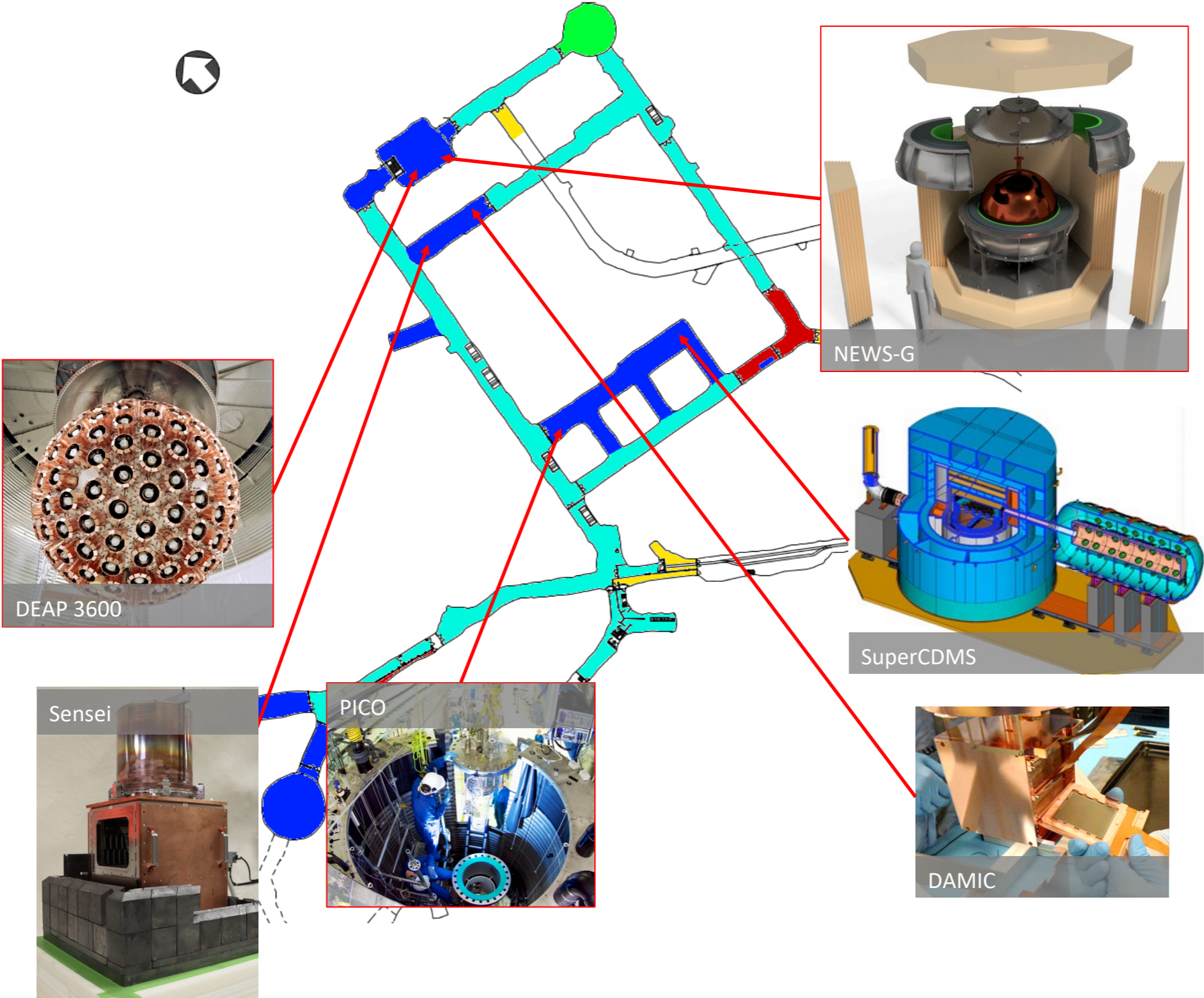

DEAP 3600

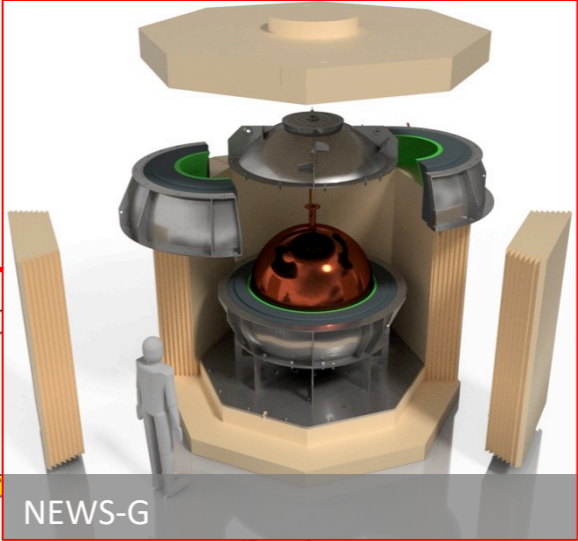

NEWS-G

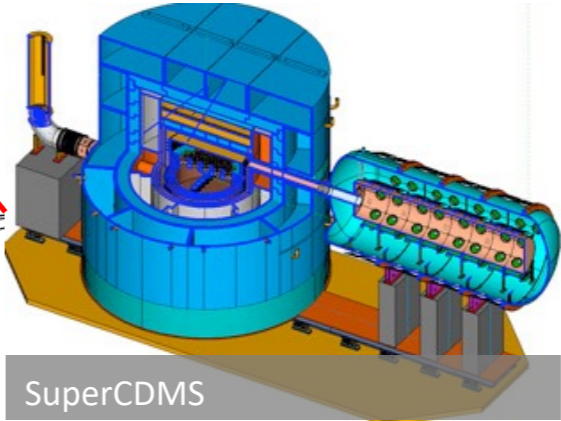

SuperCDMS



Sensei



PICO

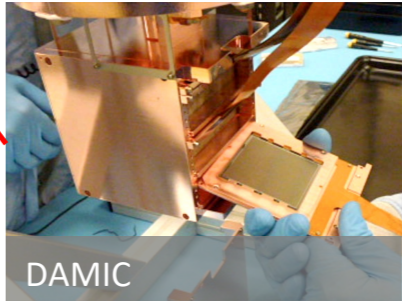

DAMIC

Deap-3600

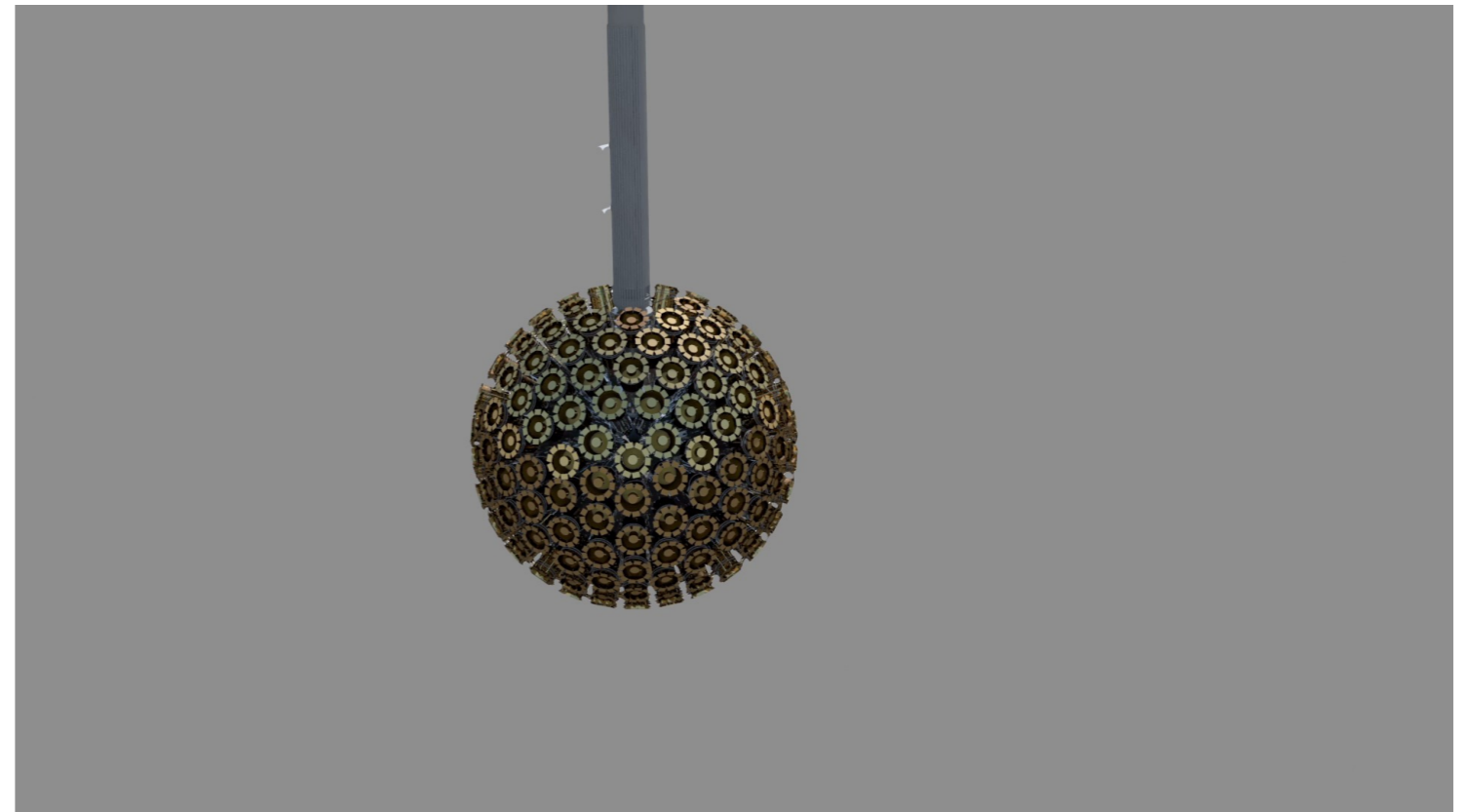
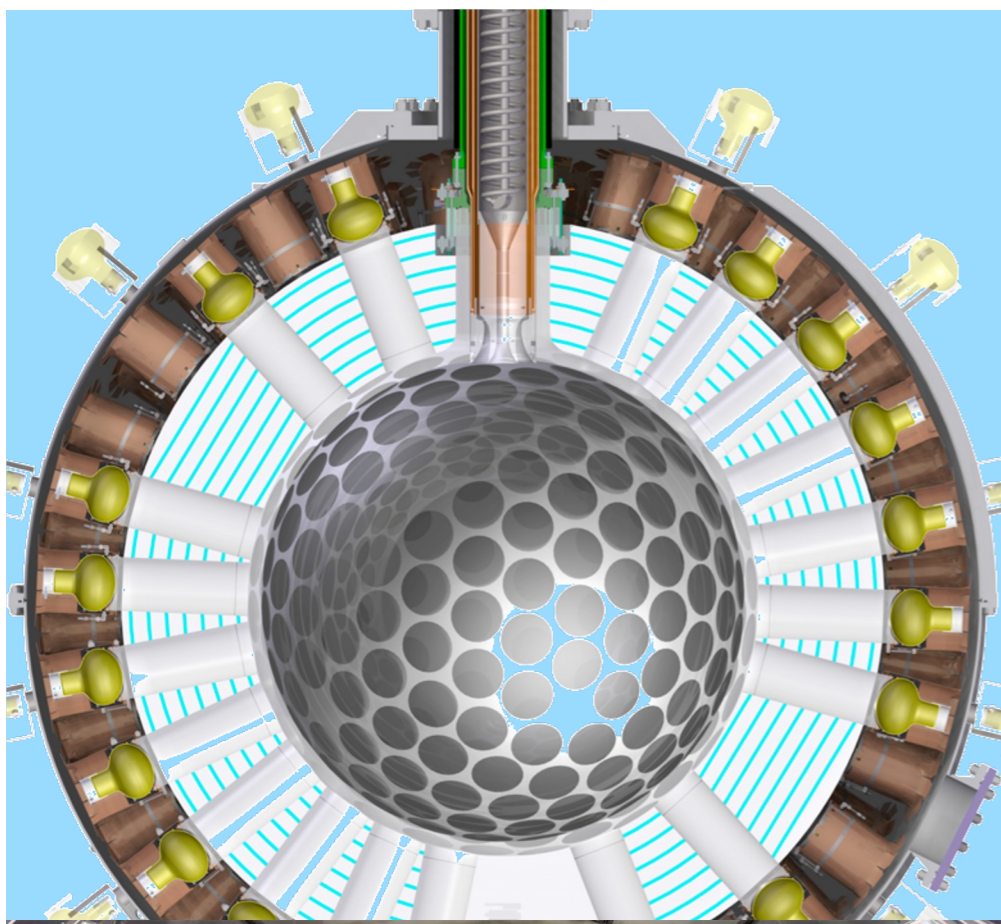

- 3600kg Liquid Argon
- Lots of mass, so DEAP-3600 is great a looking for **higher mass** DM particles.
- Signal is Scintillation at interaction, measured by Photomultiplier tubes

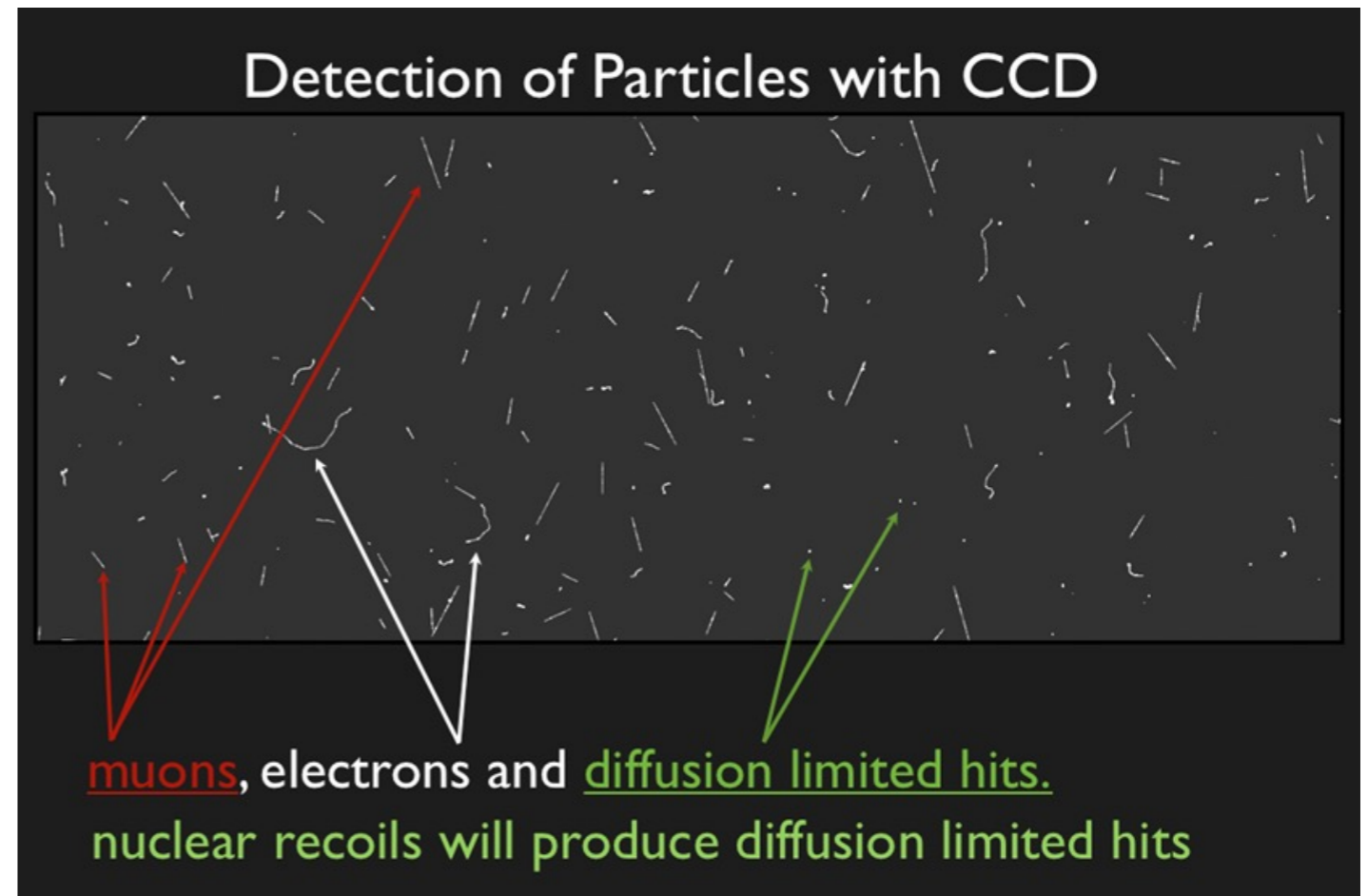
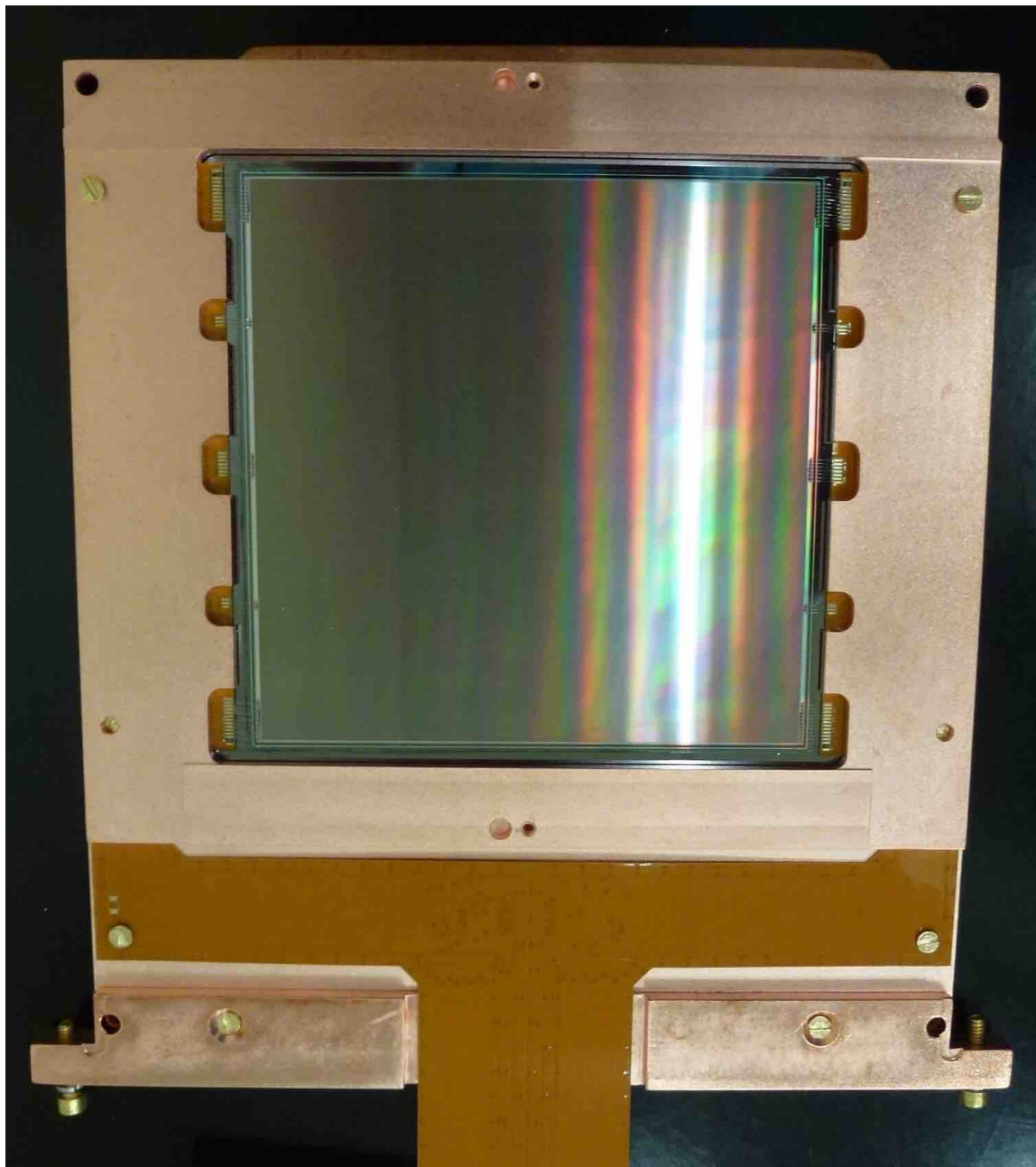

- Damirc uses Silicon CCDs (very much like the CCDs in your phone's camera). They essentially take a long exposure photo in a very shielded environment.
- Each interaction creates an identifiable signature on the photo
- Smaller detector, but very sensitive. Great for **lower mass** DM candidates which interact with either nuclei or electrons.

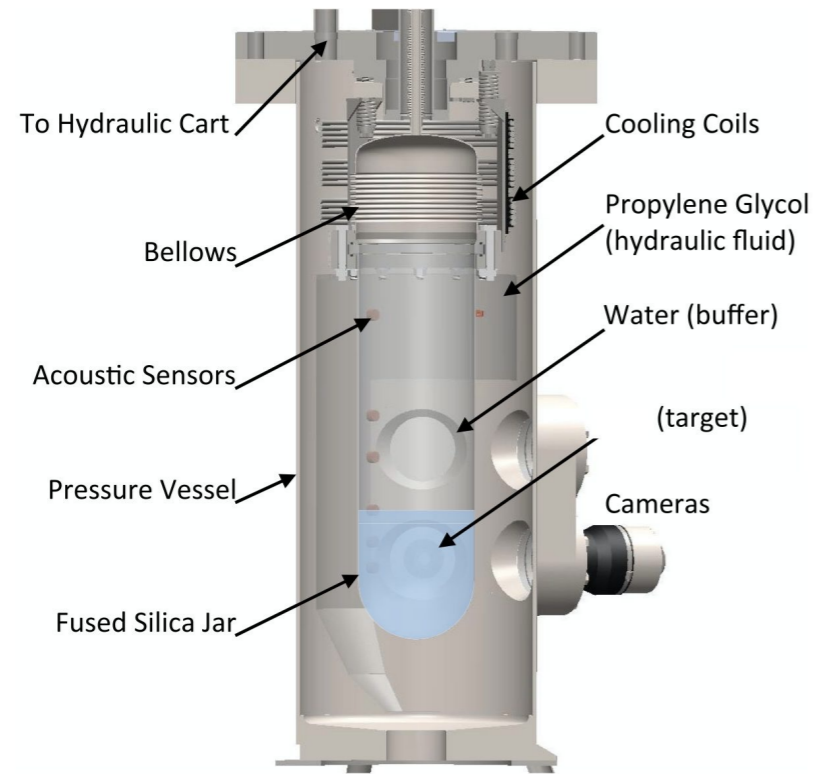

Pico

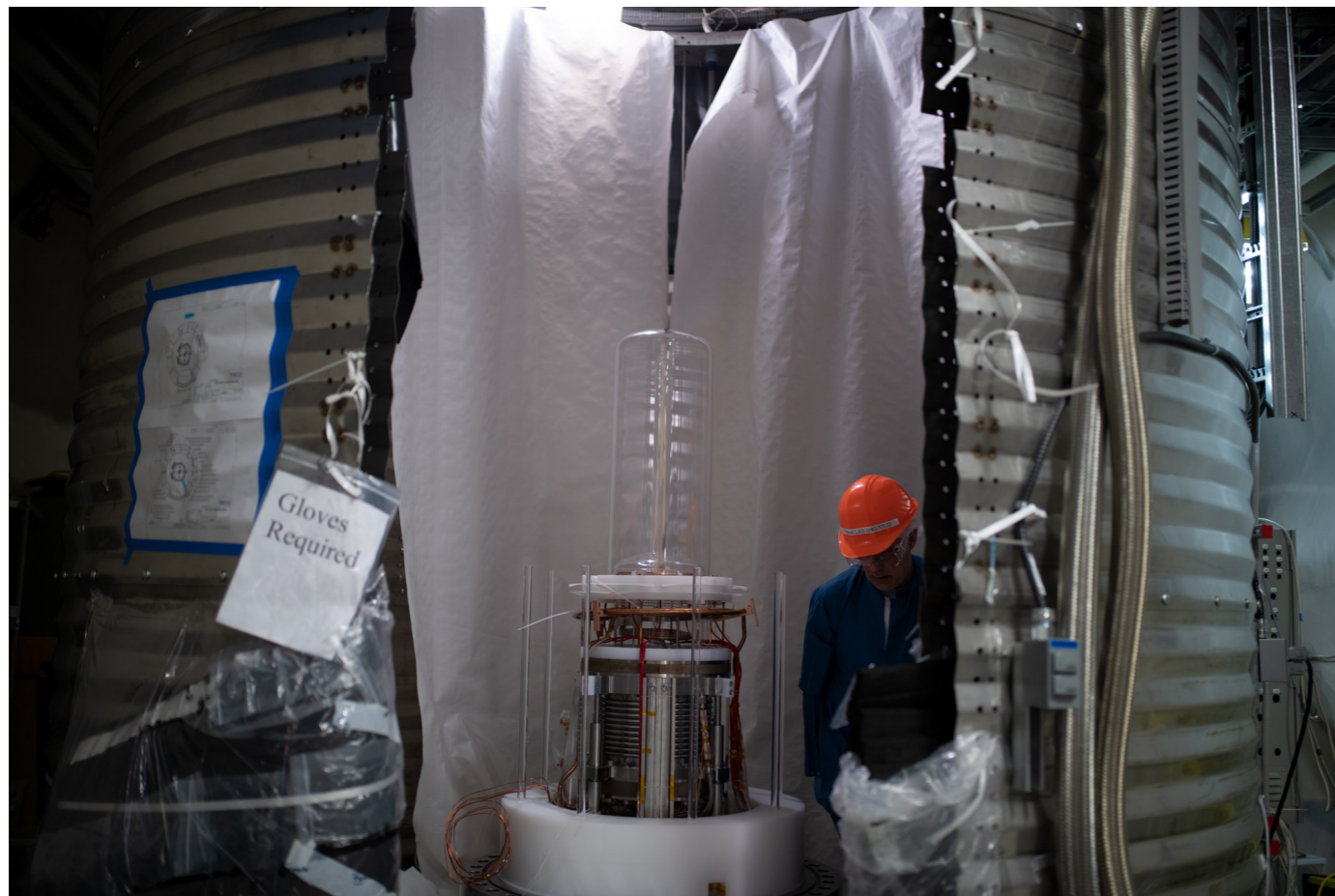
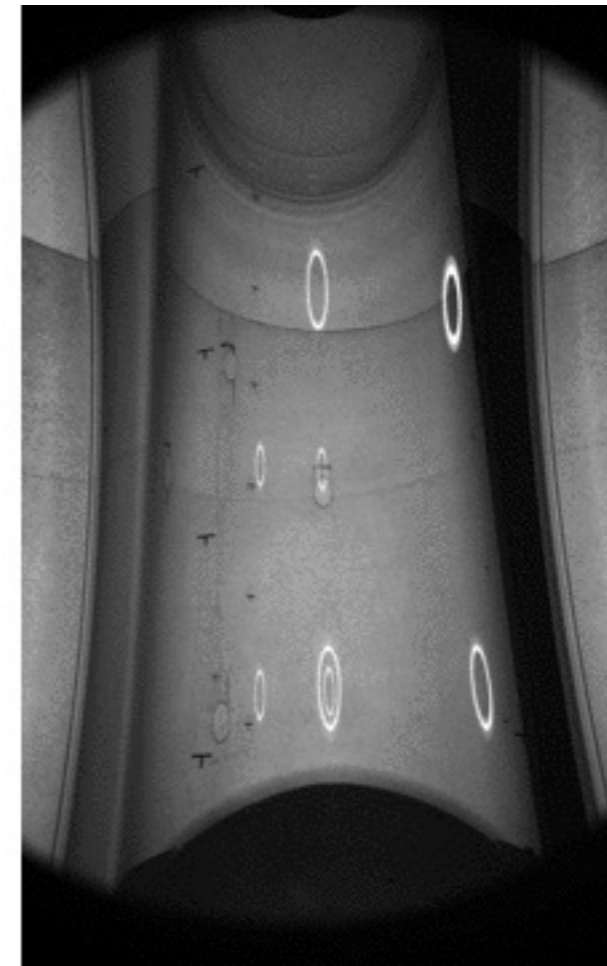

- 40L Superheated C_3F_8 Bubble chamber
- Interaction nucleates a bubble which is then caught on camera (and "heard" by sensitive microphones)
- C_3F_8 is particularly sensitive to DM candidates with **spin**. The detector is also not very sensitive to electron recoils and therefore naturally reduces a lot of backgrounds!

SuperCDMS: Super Cryogenic Dark Matter Search

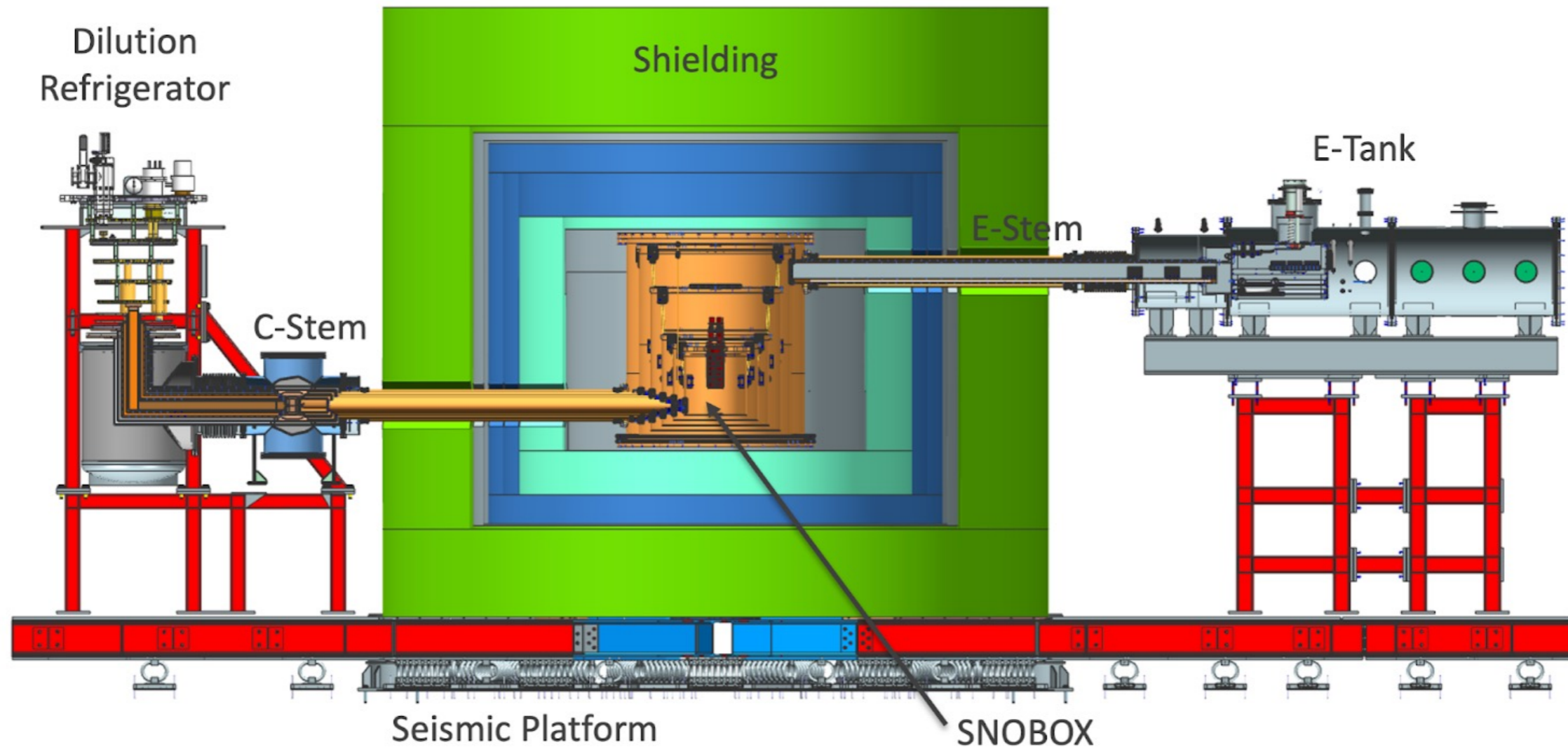

I'm going to spend a little more time on SuperCDMS than the others (because I'm working on it)...

The Phonon Channel

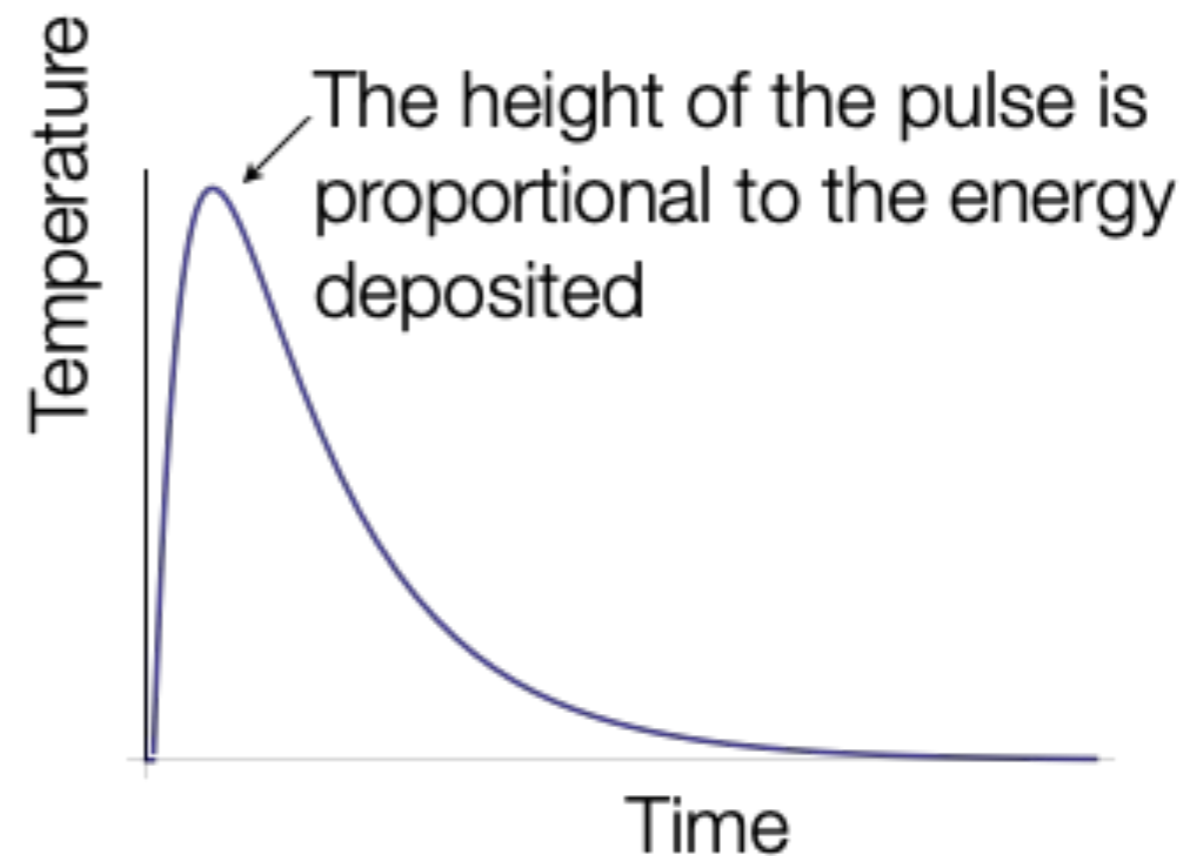
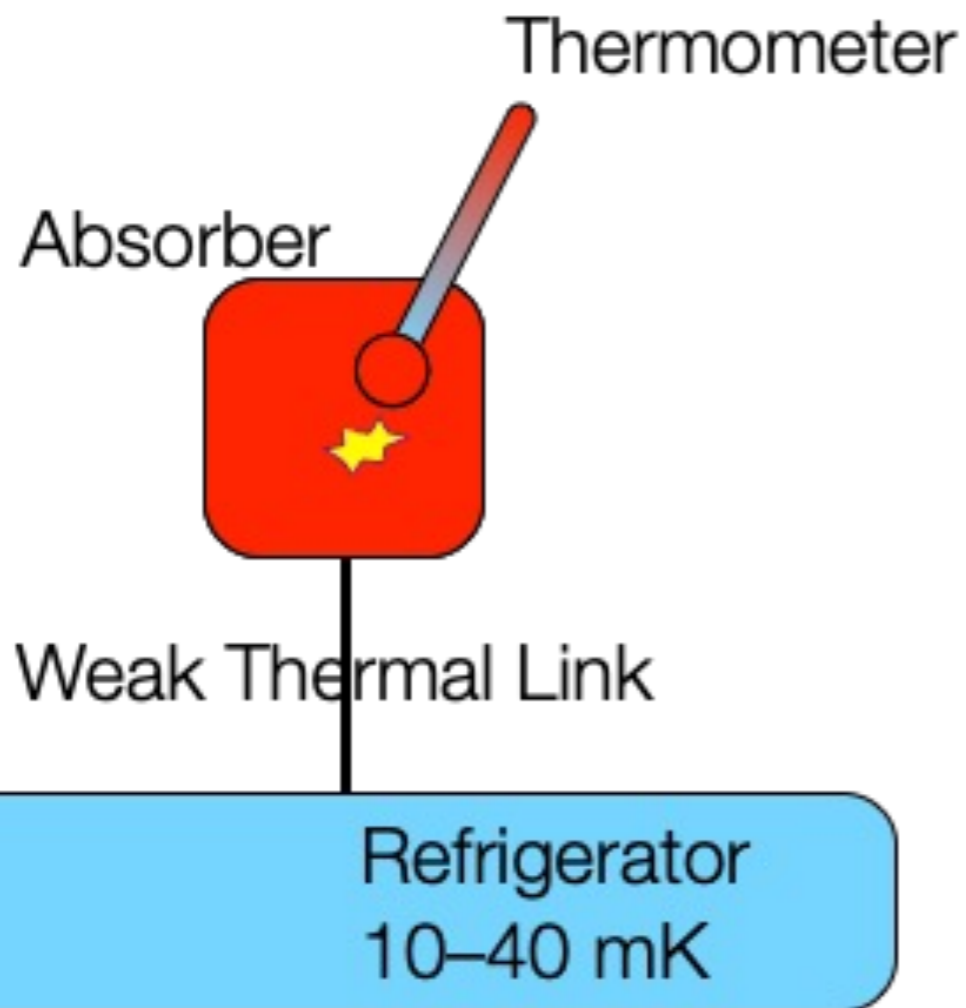

Everybody has their choice of the favourite thermometer! Ours is a Transition Edge Sensor (TES).

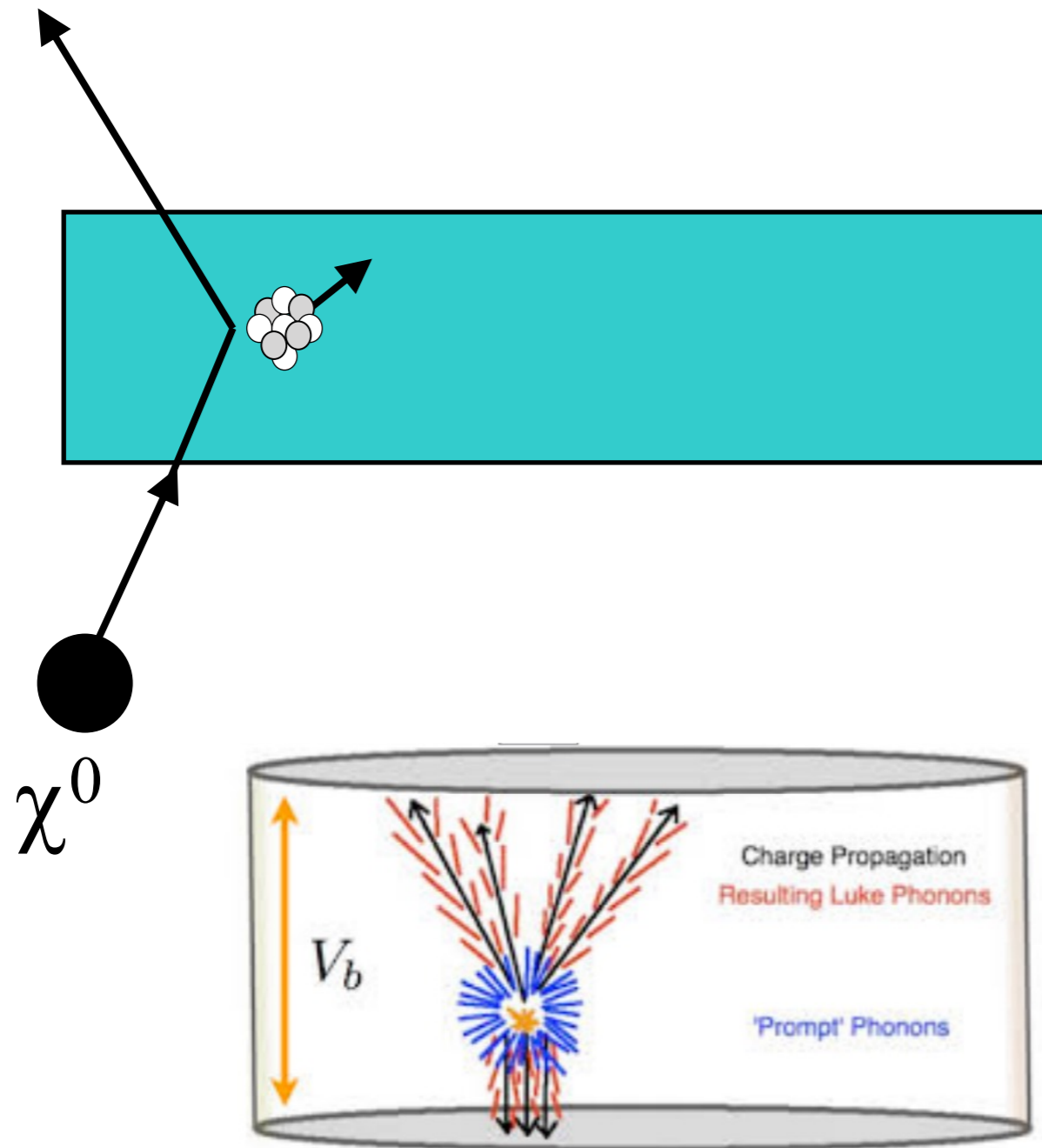

- General Idea:

- Cryogenically cooled **Ge** or **Si** crystal
- DM recoils off nucleus (or electron) in target, creating phonons (**Heat**) and liberating electron-hole pairs (**charge**)
- Phonons read out using Transition Edge Sensor (TES) array. More about this in a second.
- Electrons/holes drifted to surfaces by applying a Voltage bias to the top and bottom. This creates an electric field.

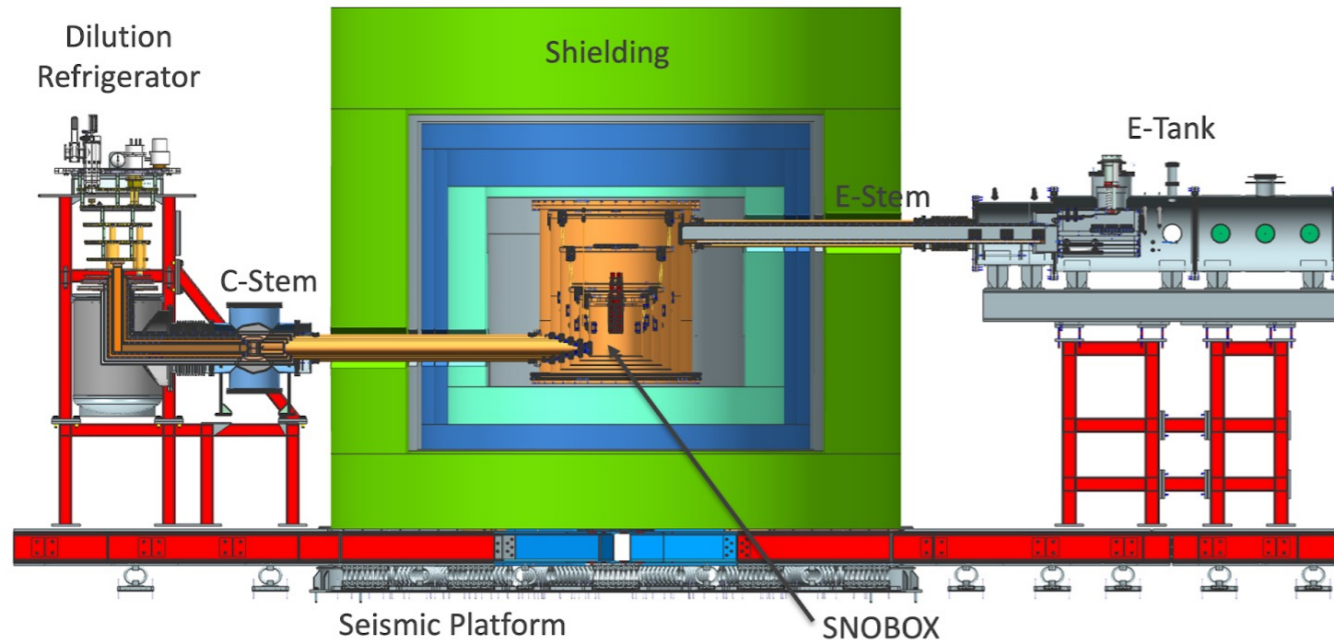

Exploiting the fundamental idea of lower temperature

- Lower amount of random motions
- Lower noise
- Better energy sensitivity & low threshold

The workhorse of SuperCDMS is our He3/He4 dilution refrigerator. This cools our detectors down to about 15 mK.

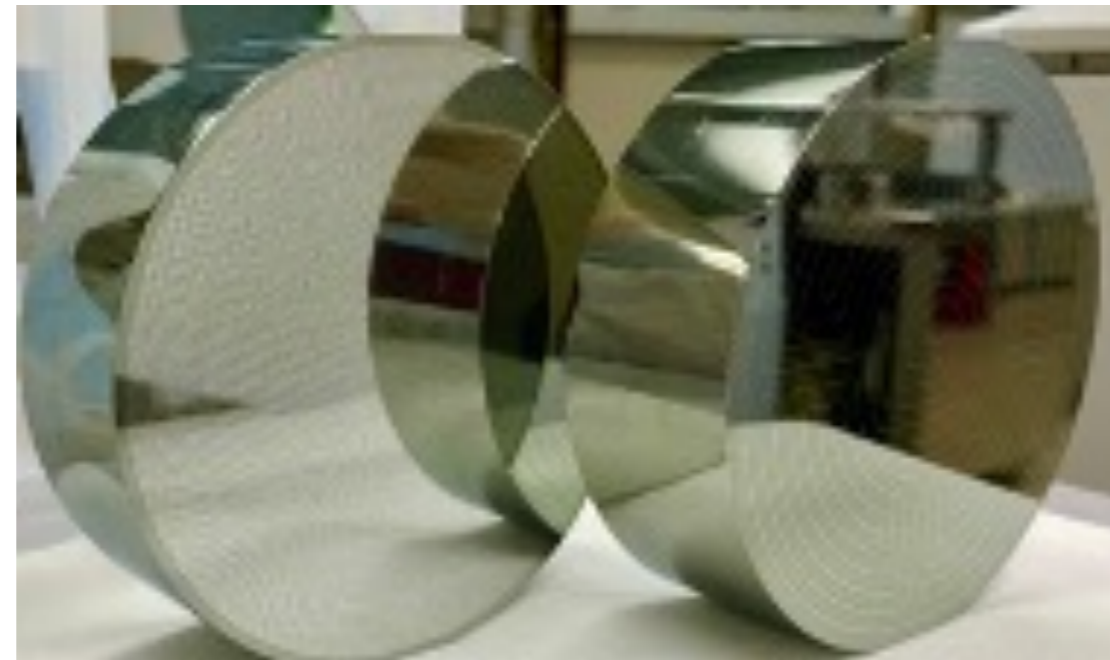
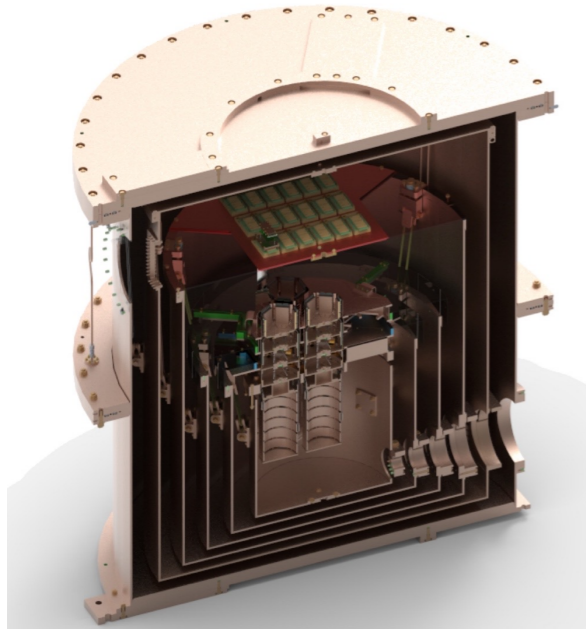

- **Cryogenic Silicon and Germanium**
 - 3"-4" diameter
 - 1"-1.33" thick

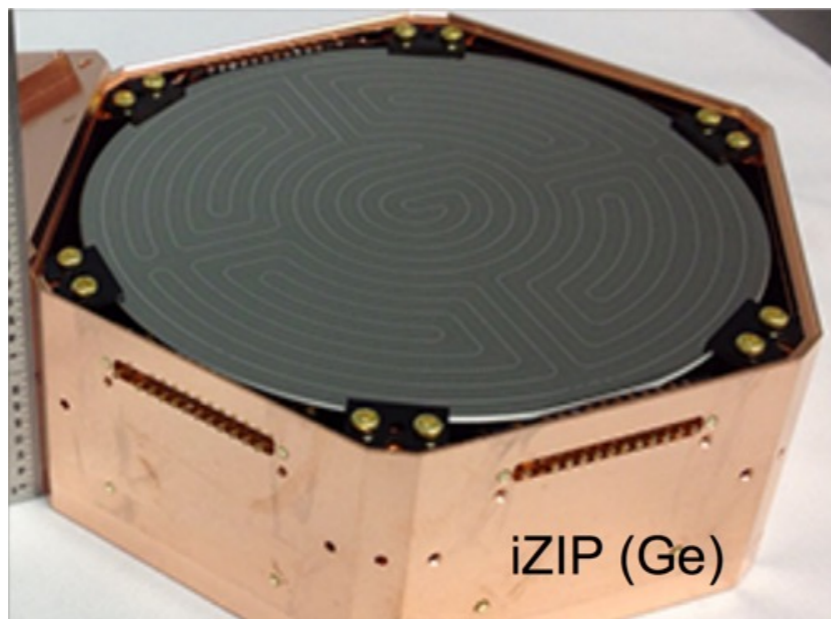

Cryogenic Underground Test Facility

CONTROLS DATA THERMOMETERS HEATERS

System Available

Lab Air Pressure (hPa): 1245.898 Lab Temperature (C): 23.7 Liquid Nitrogen Level (kg): 27.5 Tank Water Level (m): 3.0 Peltier Cooler (°C): xyz Fast Pumping Line (°C): xyz Compressor Low Pressure (psi): abc
 Compressor High Pressure (psi): abc Cooling Water In (°C): abc Helium Temp (°C): abc

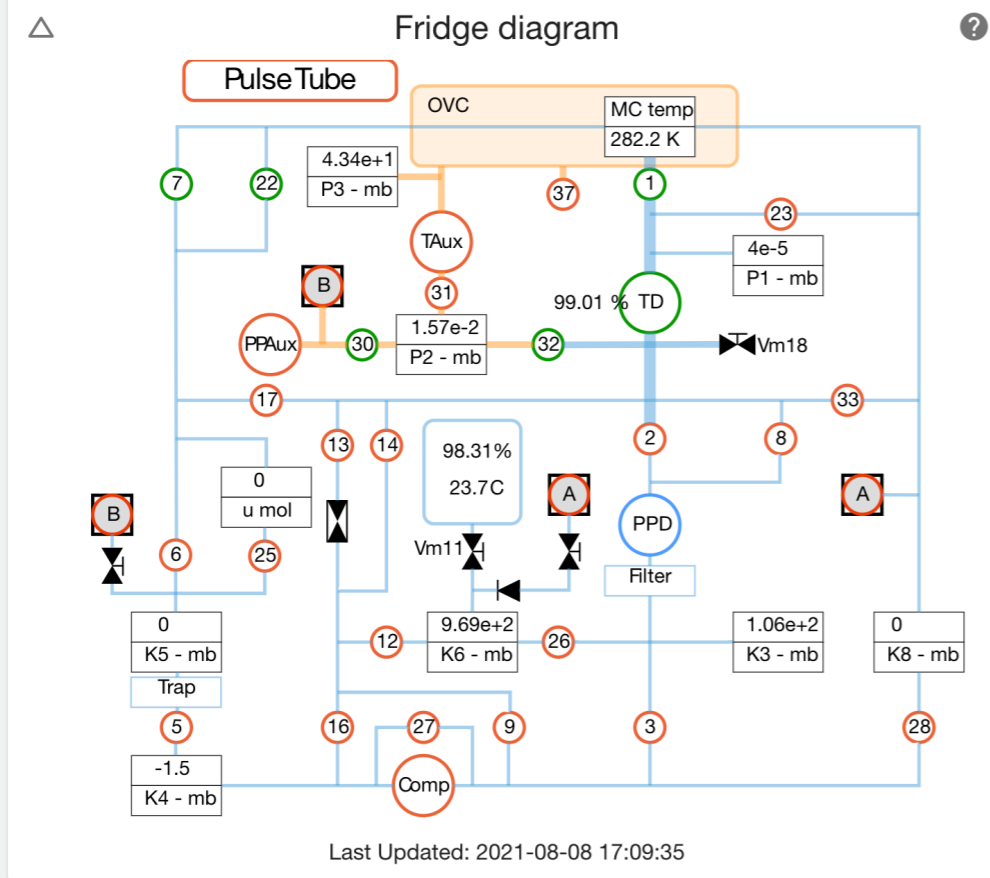

Suspension System

This panel provides real-time monitoring and control for the suspension system. It includes:

- Dampers**: Three vertical indicators (A, B, C) showing damper status. Current values are 1.21, 1.08, and 0.99 respectively.
- Motor Speed**: Three indicators (A, B, C) showing motor speed. All are currently at 0.0.
- Active Control**: A toggle switch to enable or disable active control.
- Loads (kg)**: A table showing the current load on each suspension point.
- Command Buttons (CMD1-CMD10)**: A grid of buttons for manual control.

Loads (kg)		
A	B	C
8.17	2.15	0.90

CUTE Fridge cooldown

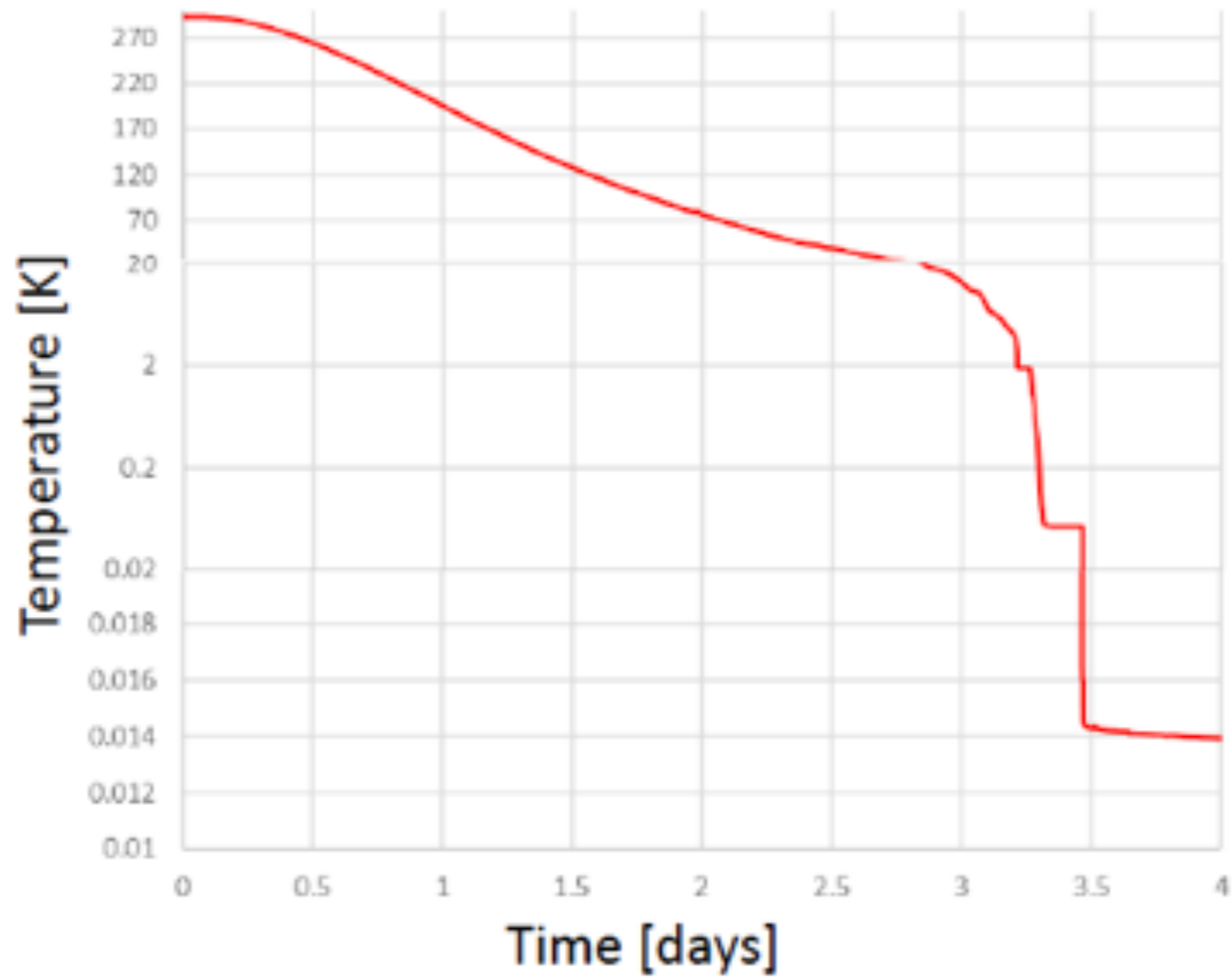

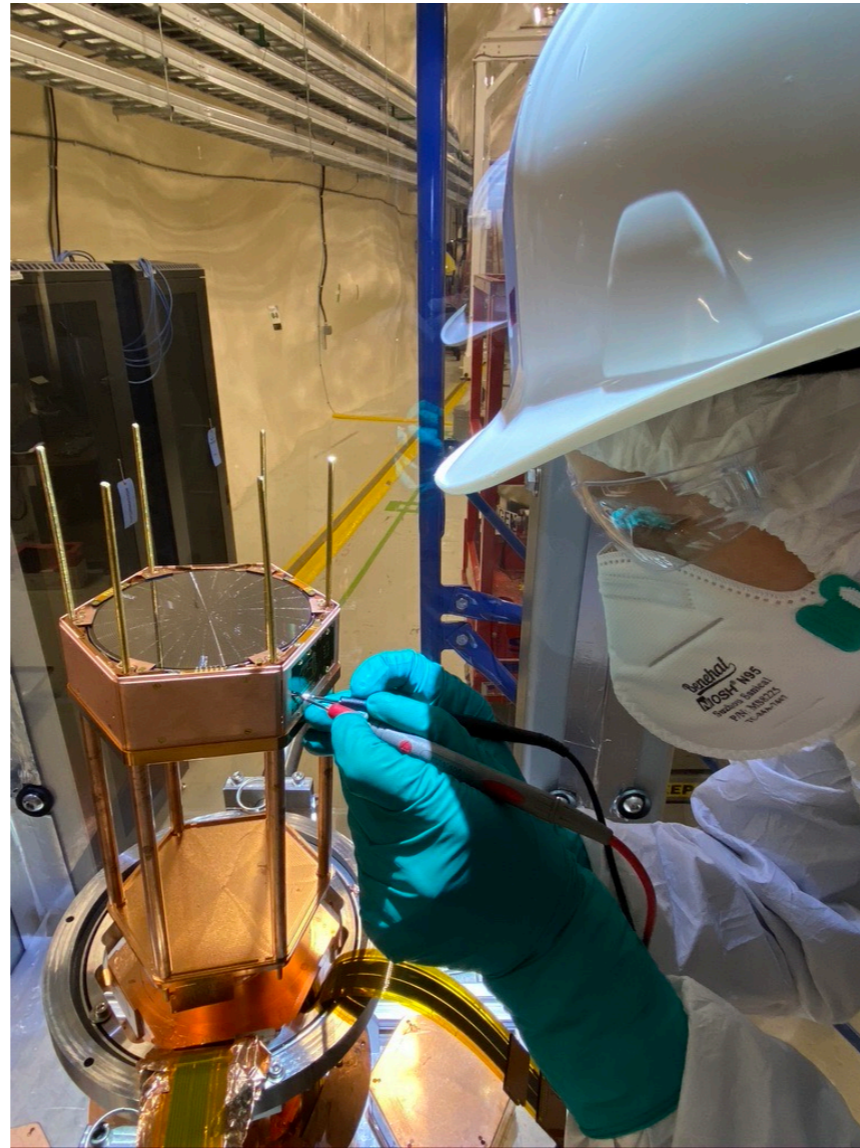
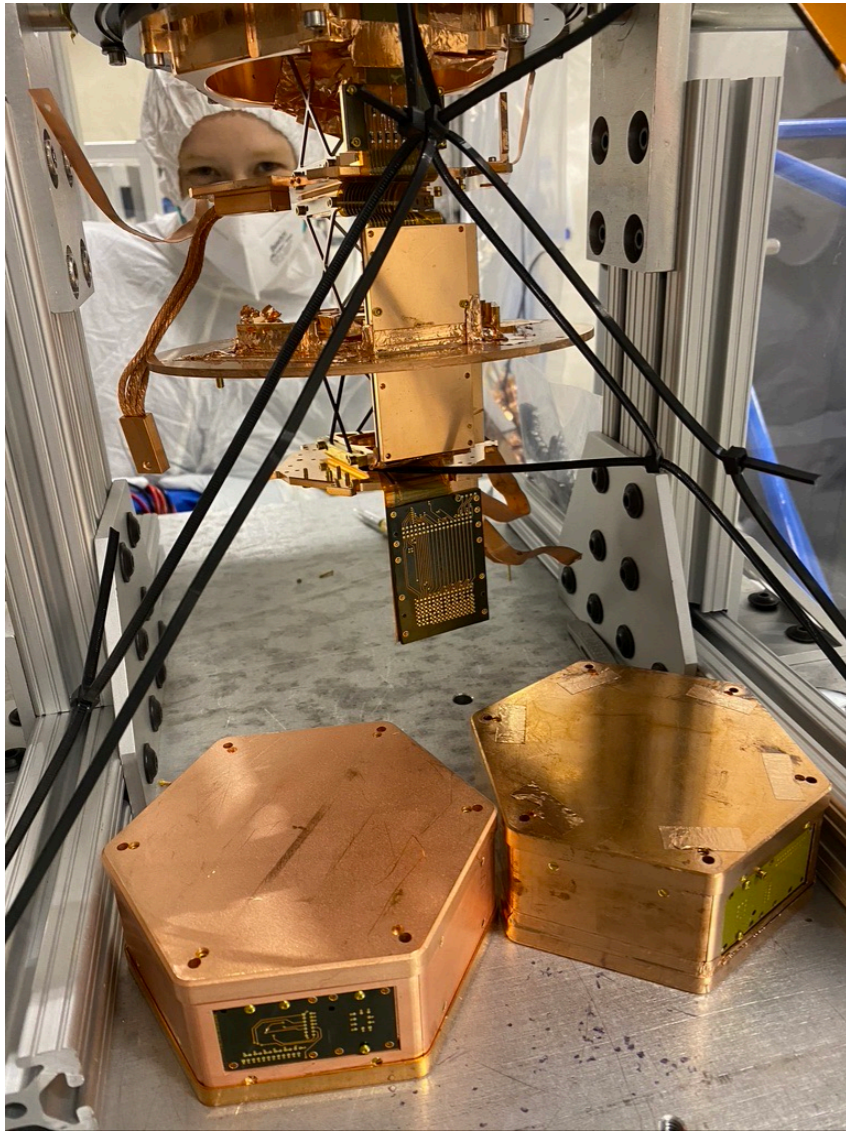

SuperCDMS Detector

Testing:

- Current work
- Single SuperCDMS HV detector (Ge or Si)
- Focus on:
 - Facility performance
 - Calibration
 - Noise hunting
 - Preparing for tower data

SuperCDMS Full Tower Test:

- Towers 3 and 4 arrived at SNOLAB earlier this year
 - Tower 3: 4 Ge and 2 Si HV detectors
 - Tower 4: 4 Ge and 2 Si iZIP detectors
- Priority is testing towers for SuperCDMS, but we hope to run long enough to get physics data as well



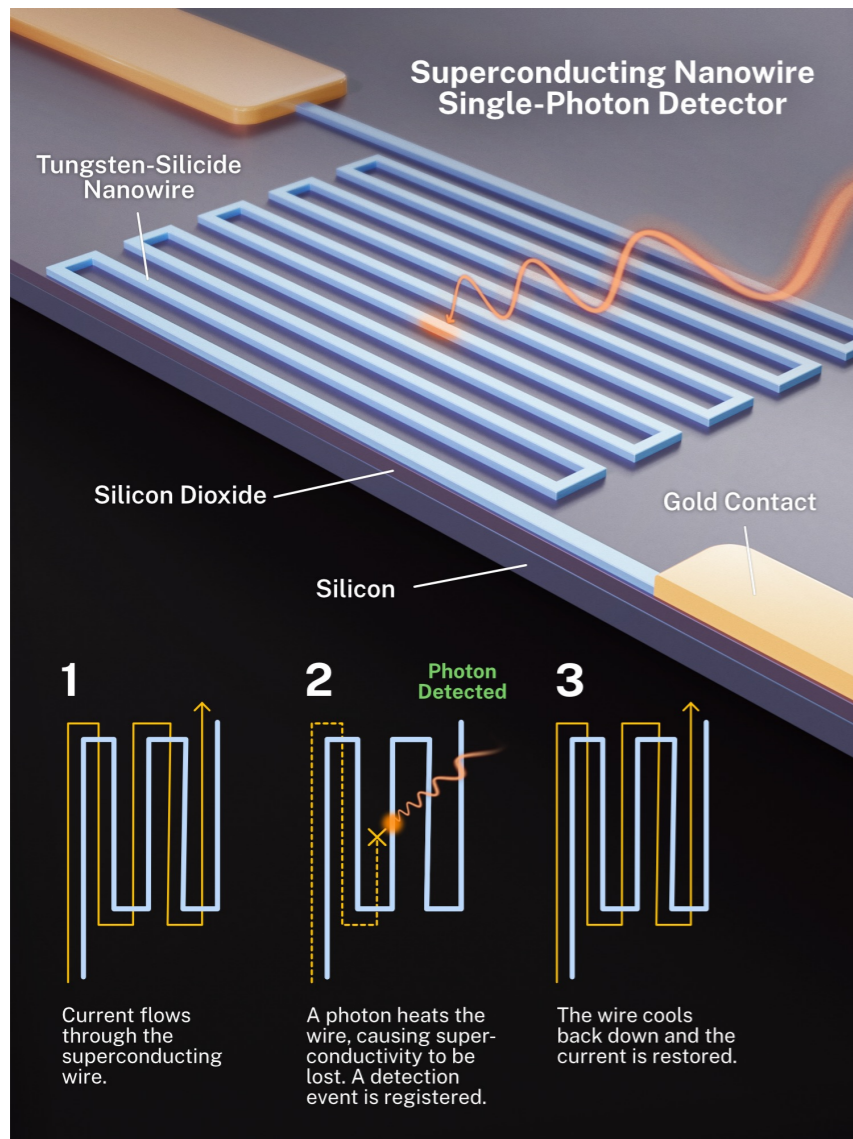

Credit: S. Kelley/NIST

How do we understand the non-ionizing radiation environment in CUTE?

- Increasingly important as we move to lower and lower energy threshold
- Can measure the infrared portion using Superconducting Nanowire Single-Photon Detectors (SNSPDs)
- Sensitive to short-wave infrared photons
- Spectral information from tunable threshold
- Simple readout, low cost to set up
- Potential for DM hunting as well

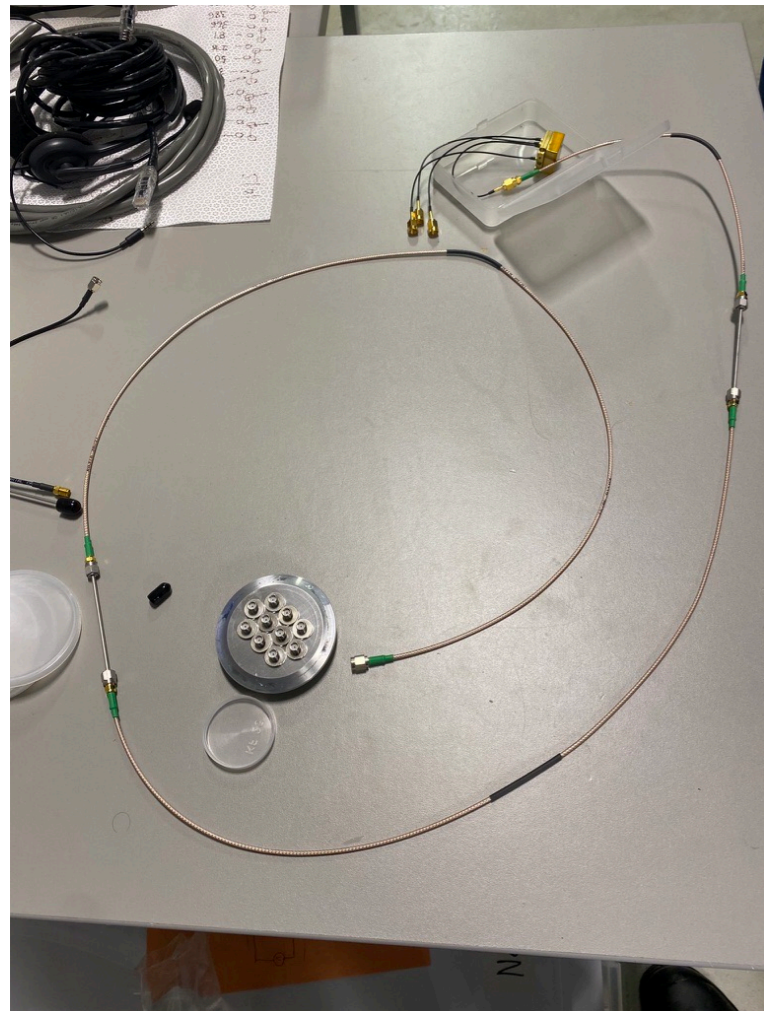

Collaboration between SNOLAB and NIST

- Proof of principle device in hand
- Can run at 1 Kelvin so testing can be in parallel with other projects
- Currently working on readout wiring, hope to test device soon

- HVeV Detectors Underground
 - Proposal for 5 detectors
 - Plan for readout and installation underway

Laser data at 100 V

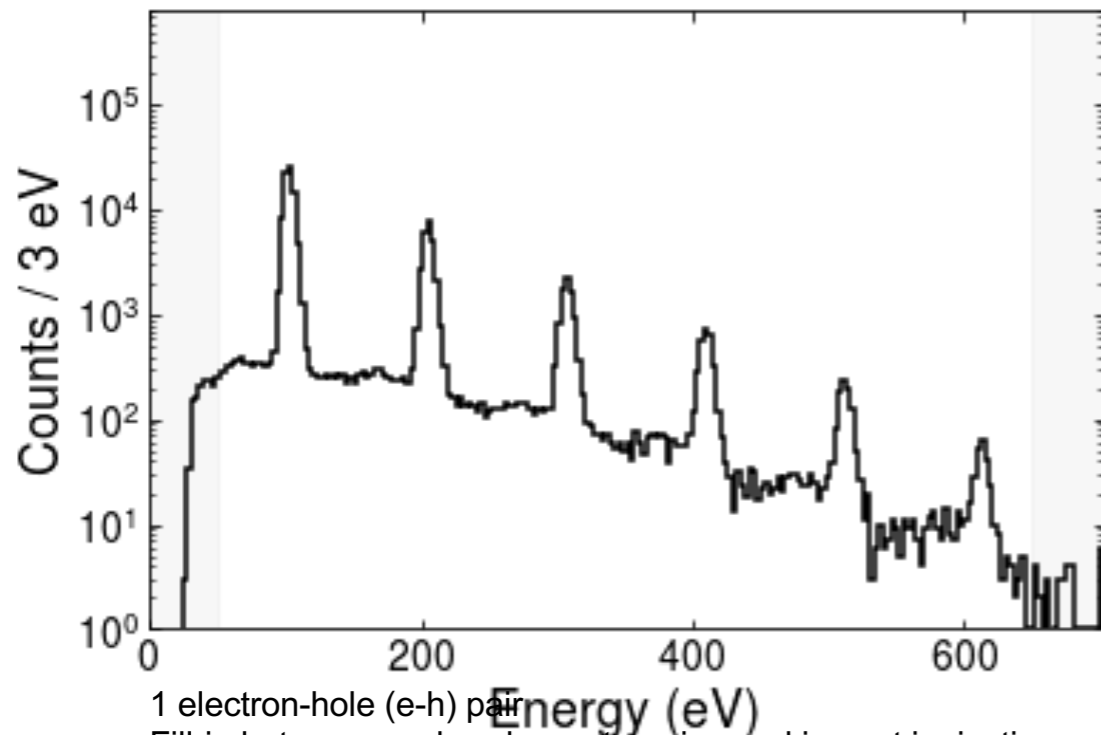

1 electron-hole (e-h) pair
Fill-in between peaks: charge trapping and impact ionization

See Ziqing's talk from yesterday!

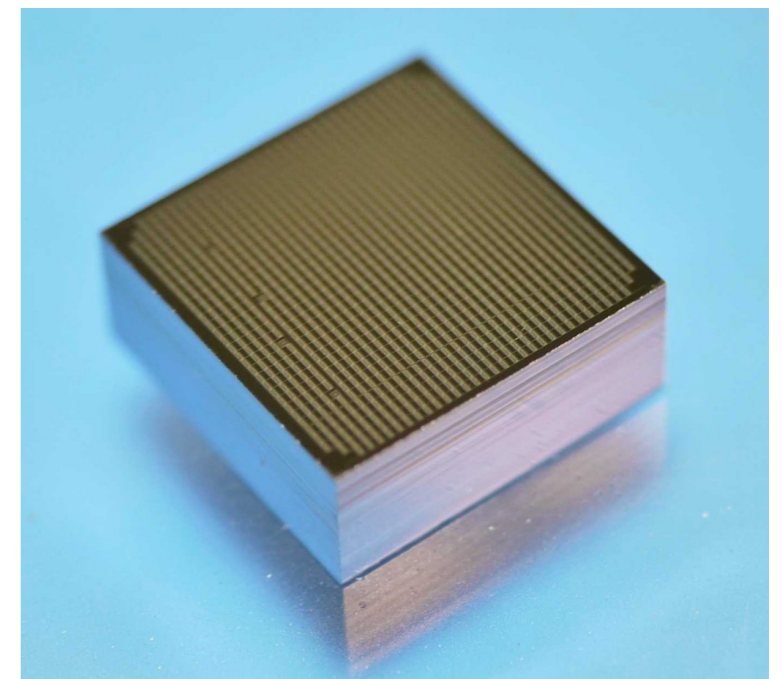

D. W. Amaral *et al.*, Phys. Rev. D 102, 091101(R), 2020
F. Ponce, *et al.*, Phys. Rev. D 101, 031101(R), 2020
R. Ren *et al.*, Phys. Rev. D 104, 032010, 2021



The CUTE Team



PI	until 2020: G. Gerbier (W. Rau: Co-PI) since 2020: W. Rau
Project Manager	until 2017: Ph. Camus 2018-2020: S. Nagorny
Operations Manager	until 2022: S. Scorza, A. Kubik interim
SNOLAB team	A. Kubik, J. Hall, S. Scorza (until 2022) (Research Scientists) J. Gauthier (until 2022) (Operations Engineer) R. Schleeahn (Operations Engineer) J.M. Olivares (Technical support) M. Baiocchi, A. Pleava, S. Jess, Y. Esenullah (students) Support from SNOLAB technical team
On-site work	J. Corbett, M. Ghaith, S. Nagorny (until 2020)
Off-site	R. Germond (slow control) Z. Hong (facility upgrades) T. Aramaki (payload) B. Serfass, E. Fascione, E. Michielin, R. Underwood, Y. Liu et al (DAQ) A. Mayer, S. Pandey, T. Reynolds, A. Reyes, V. Iyer, A. Pradeep, M. Al-Bakry, R. Bhattacharyya, S. Dharani P. Pakarha (2018/19, calibration) K. Dering, S. Crawford (design engineering, until 2019/20)