



# Welcome

Dave Newbold, Executive Director of National Laboratories, STFC



# STFC's mission

## Mission:

- Discovering the secrets of the Universe
- Developing advanced technologies
- Solving real world challenges

## Responsibilities:

- Frontier research: particle physics, astronomy, nuclear physics and space science
- Major UK multi-disciplinary facilities
- Stewardship of our R&I campuses

**Annual budget: ~£1.1b**



# STFC's mission

## Mission:

- Discovering the secrets of the Universe
- Developing advanced technologies
- Solving real world challenges

## Responsibilities:

- Frontier research: particle physics, astronomy, nuclear physics and space science
- **Major UK multi-disciplinary facilities**
- **Stewardship of our R&I campuses**

**Annual budget: ~£1.1b**

## Key enabling technologies:

- Quantum sensing
- Quantum computing
- Artificial intelligence
- Advanced accelerators
- Extreme-scale classical computing
- Advanced microelectronics
- Big data



# STFC's science base

Six sites across the UK + ING in La Palma

Around 3,000 staff

- approx. 30% of UKRI staff
- >85% are scientists, engineers and technicians

- **1660** at the Rutherford Appleton Lab

## STFC National Laboratories

- STFC provides the necessary high-tech scientific and engineering support for >10,000 industrial and academic researchers from **across all domains**





# STFC's global reach

## Includes:

- CERN
- Fermilab
- ESO
- ILL
- SKA
- ESRF
- XFEL
- ESS
- ESA
- ING
- ...

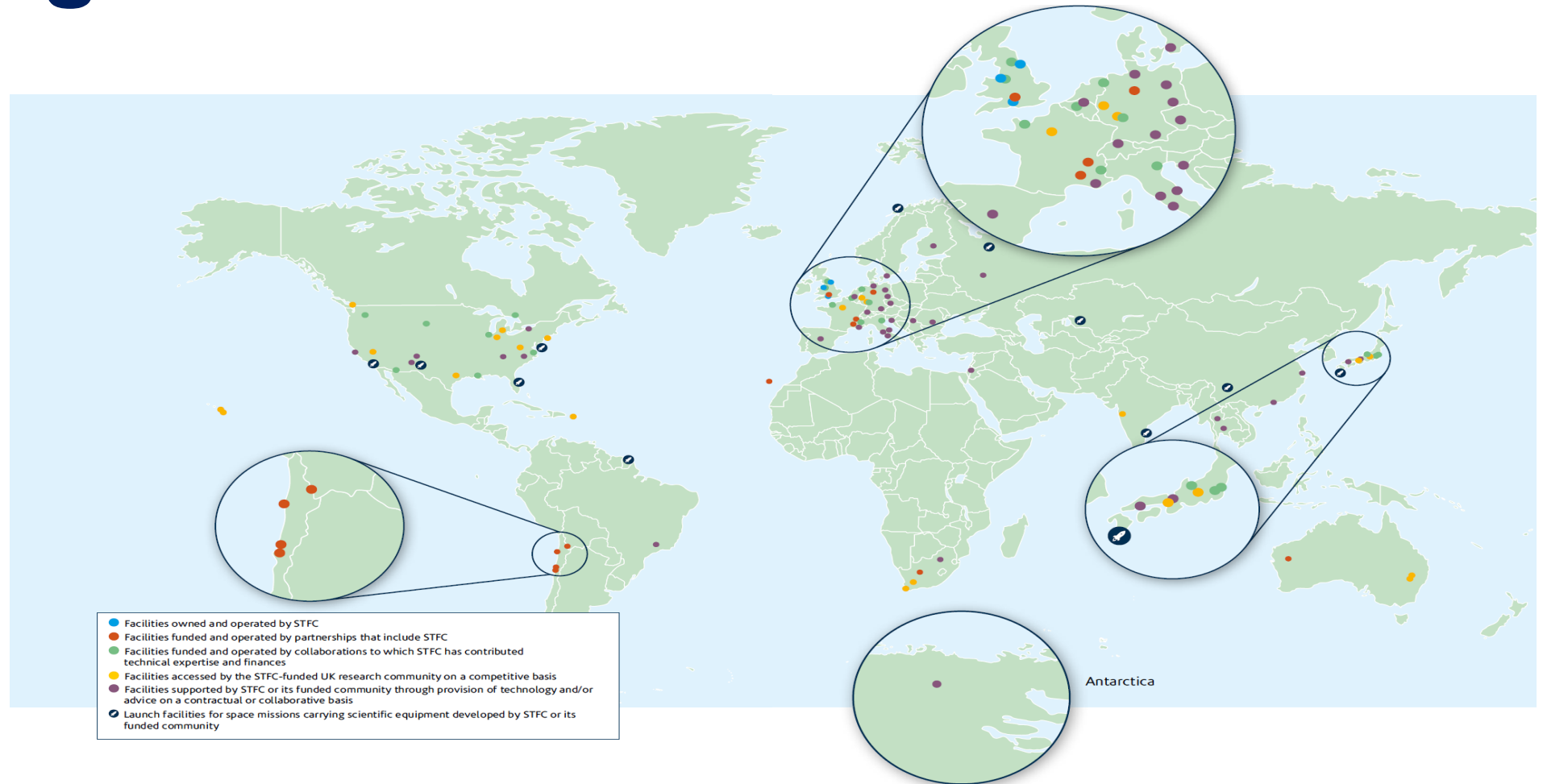



# National Quantum Strategy

March 2023

Our **ten-year vision** is for the UK to be a world leading **quantum-enabled economy**, building on scientific excellence and creating a thriving quantum sector to ensure that quantum technologies are an integral part of the UK's digital infrastructure and advanced manufacturing base, driving growth and helping to build a strong and resilient economy and society.

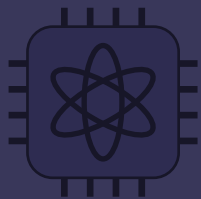

Ensure the UK is home to world-leading quantum science and engineering, growing UK knowledge and skills



Support business, making the UK the go-to place for quantum businesses and an integral part of the global supply chain, as well as a preferred location for investors and global talent



Drive the use of quantum technologies in the UK to deliver benefits for the economy, for society and for our national security



Create a national and international regulatory framework that supports innovation and the ethical use of quantum technologies, and protects UK capabilities and national security

Department for  
Science, Innovation  
& Technology

National Quantum Strategy

March 2023



# National Quantum Strategy

March 2023

Our ten-year vision is for the UK to be a world leading quantum-enabled economy, building on scientific excellence and creating a thriving quantum sector to ensure that quantum technologies are an integral part of the UK's digital infrastructure and advanced manufacturing base, driving growth and helping to build a strong and resilient economy and society.

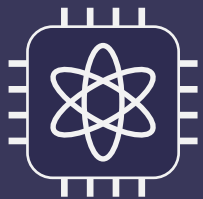

Ensure the UK is home to world-leading quantum science and engineering, growing UK knowledge and skills



Support business, making the UK the go-to place for quantum businesses and an integral part of the global supply chain, as well as a preferred location for investors and global talent



Drive the use of quantum technologies in the UK to deliver benefits for the economy, for society and for our national security



Create a national and international regulatory framework that supports innovation and the ethical use of quantum technologies, and protects UK capabilities and national security

 Department for  
Science, Innovation  
& Technology

- **10yr £2.5bn**
- Research Hubs
- Skills
- International partners
- Quantum missions
- Innovation funding
- Tech accelerators

March 2023



# National Quantum Strategy

March 2023

Our ten-year vision is for the UK to be a world leading quantum-enabled economy, building on scientific excellence and creating a thriving quantum sector to ensure that quantum technologies are an integral part of the UK's digital infrastructure and advanced manufacturing base, driving growth and helping to build a strong and resilient economy and society.

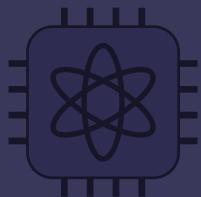

Ensure the UK is home to world-leading quantum science and engineering, growing UK knowledge and skills



Support business, making the UK the go-to place for quantum businesses and an integral part of the global supply chain, as well as a preferred location for investors and global talent



Drive the use of quantum technologies in the UK to deliver benefits for the economy, for society and for our national security



Create a national and international regulatory framework that supports innovation and the ethical use of quantum technologies, and protects UK capabilities and national security

Department for  
Science, Innovation  
& Technology

- **10yr £2.5bn**
- Applications focus
- Develop use-cases
- Test bed access
- Gov procurement

March 2023



# National Quantum Strategy

March 2023

Our ten-year vision is for the UK to be a world leading quantum-enabled economy, building on scientific excellence and creating a thriving quantum sector to ensure that quantum technologies are an integral part of the UK's digital infrastructure and advanced manufacturing base, driving growth and helping to build a strong and resilient economy and society.

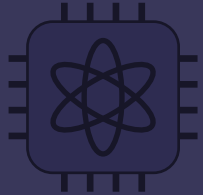

Ensure the UK is home to world-leading quantum science and engineering, growing UK knowledge and skills



Support business, making the UK the go-to place for quantum businesses and an integral part of the global supply chain, as well as a preferred location for investors and global talent



Drive the use of quantum technologies in the UK to deliver benefits for the economy, for society and for our national security



Create a national and international regulatory framework that supports innovation and the ethical use of quantum technologies, and protects UK capabilities and national security

Department for  
Science, Innovation  
& Technology

- **10yr £2.5bn**
- Commercialisation
- Infrastructure
- Business support
- Supply chain growth
- Inward investment
- Global trade

March 2023

# National Quantum Strategy

March 2023

Our ten-year vision is for the UK to be a world leading quantum-enabled economy, building on scientific excellence and creating a thriving quantum sector to ensure that quantum technologies are an integral part of the UK's digital infrastructure and advanced manufacturing base, driving growth and helping to build a strong and resilient economy and society.

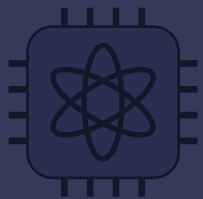

Ensure the UK is home to world-leading quantum science and engineering, growing UK knowledge and skills



Support business, making the UK the go-to place for quantum businesses and an integral part of the global supply chain, as well as a preferred location for investors and global talent



Drive the use of quantum technologies in the UK to deliver benefits for the economy, for society and for our national security



Create a national and international regulatory framework that supports innovation and the ethical use of quantum technologies, and protects UK capabilities and national security

Department for  
Science, Innovation  
& Technology

- **10yr £2.5bn**
- **Trusted Research**
- **Technical Standards**
- **Technical Assurance**
- **Cyber Security**
- **Economic protection**
- **Ethical deployment**

March 2023



# National Quantum Computing Centre

- Collaborative Programme: EPSRC and STFC
  - £100m initial 5 year investment (2020)
  - £50m programme acceleration (2023)
- Addressing the challenges of scaling quantum computing
  - Delivery through in-house development, UK and international collaborations and government procurement
  - Full stack architecture: hardware and software
  - Scalability: benchmarking, verification and error correction
  - Deployment: use-cases, algorithms and applications
  - Building and eco-system: Skills, training and engagement
- Driving user adoption and economic value through our SparQ quantum readiness engagement programme



Technology

Infrastructure

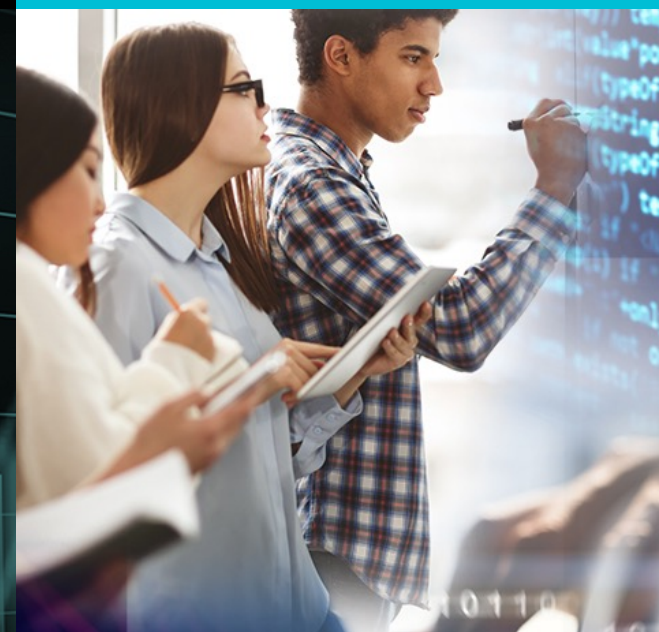

Applications

Skills

# National Quantum Computing Centre

## Quantum Computing Testbeds

### Strategic Intent:

- Gain access to a range of platforms enabling evaluation and benchmarking of performance
- Drive both in-house development and external platform evaluation
- Evaluate and de-risk deployment to help drive user-adoption
  - cost, time, performance ...
- Accelerating UK Government as an informed customer and user

### £35m investment

- 15 month deployment
- 24 month evaluation

Supplier	Platform Type
AEGIQ	Photonic
Cold Quanta UK	Cold Atom Tweezer Array
ORCA Computing	Photonic
Oxford Ionics	Trapped Ions
Quantum Motion	Si Quantum Dots
QuEra Computing	Cold Atom Tweezer Array
Rigetti UK	Superconducting

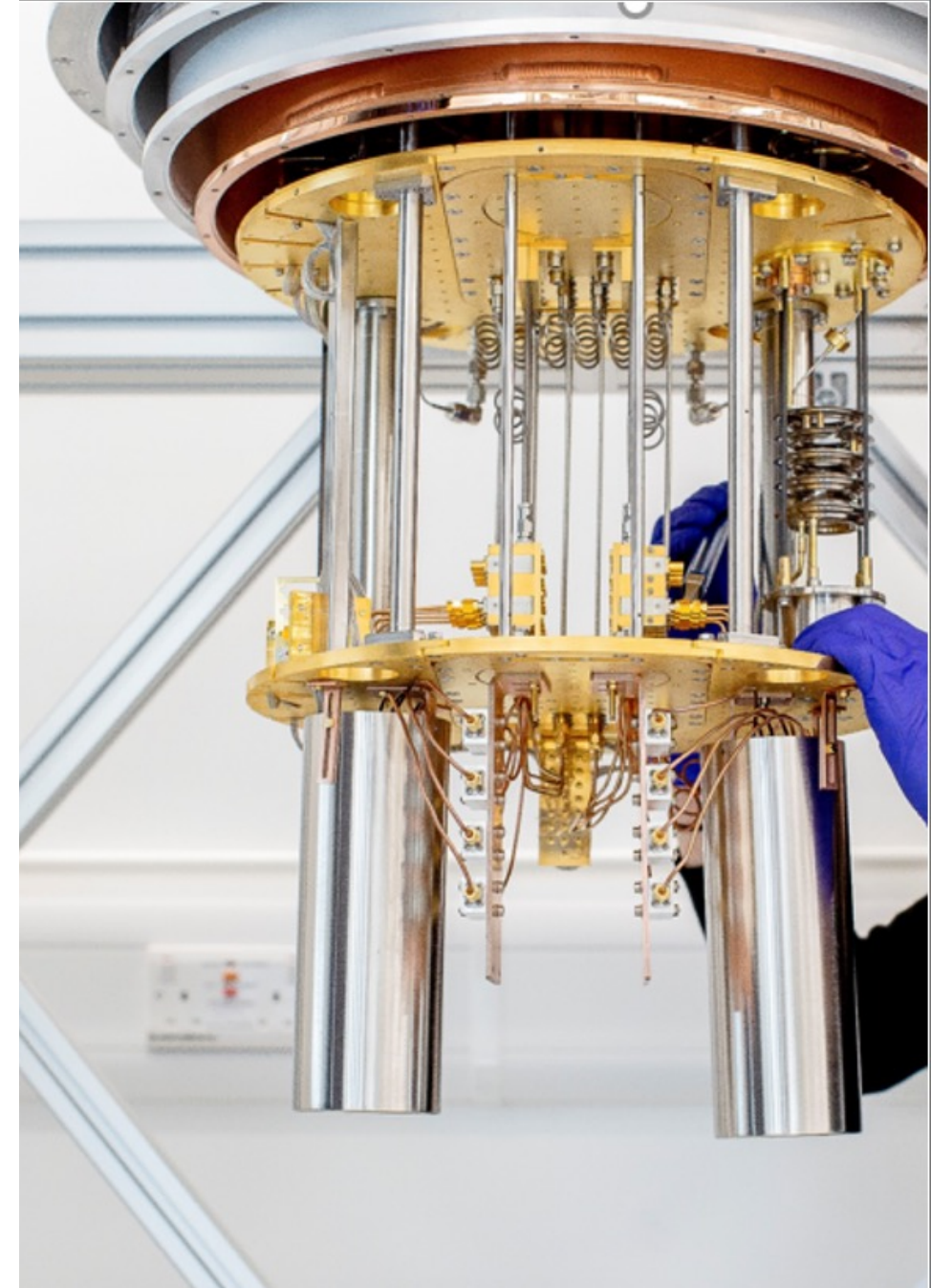



# Quantum Computing @ The Hartree Centre

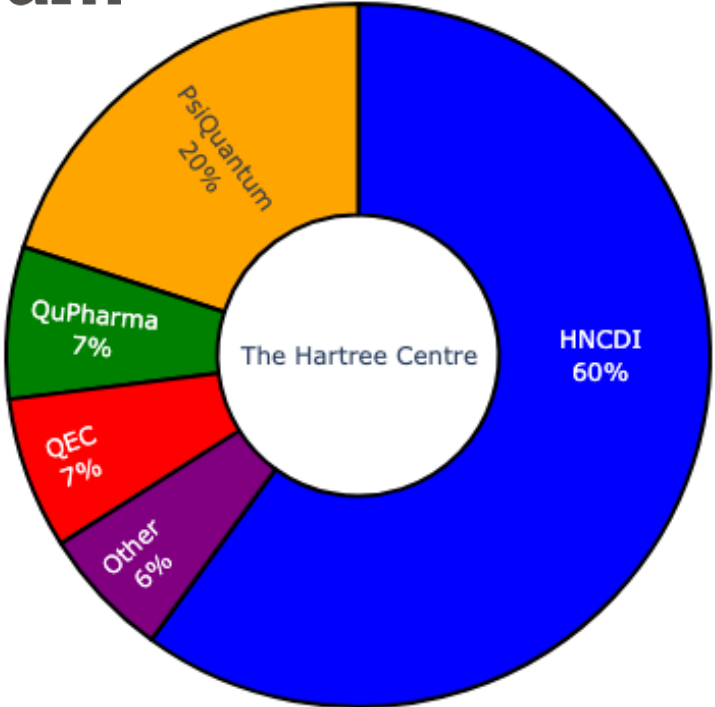

Plus Academic engagement in the North-West



# History of QTFP

**July 2018** Idea presented to STFC

**October 2018** Opportunities grant: Quantum Sensors for Fundamental Physics (QSFP) and Society awarded

**Oct 2018/Jan 2019** QSFP Community workshops

**March 2019** Business case approved

**May 2019** STFC Led Community workshop

**September 2019** First Call announced

**January 2020** QSFP 1st School

**January 2021** Successful proposals announced

**November 2021** QTFP presence at NQTP Showcas

**September 2022** Successful second call proposals announced

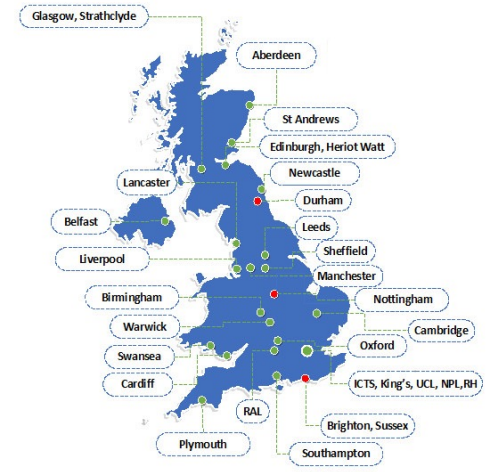

QSFP UK Institutions



The first Quantum Sensors for Fundamental Physics Community Workshop

Quantum projects launched to solve the universe's mysteries



£6 million to spur the UK's quantum leap

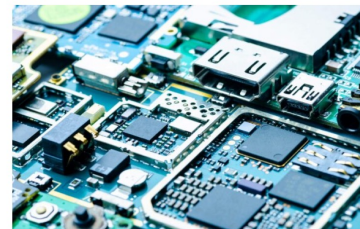

Engineering and Physical Sciences Research Council



Science and Technology Facilities Council



# QTFP Objectives

- Establish a new community to exploit quantum technology for fundamental physics. Generating research outputs deemed excellent by international peer review
- Position the UK as a first rank nation in the scientific exploitation of quantum technology for physics applications
- Become an active player in the National Quantum Technology Programme (NQTP)
- Create the opportunity in the UK for new patents, new products and start-up companies as a result of developing new or improved equipment that will be needed to support the scientific work programme

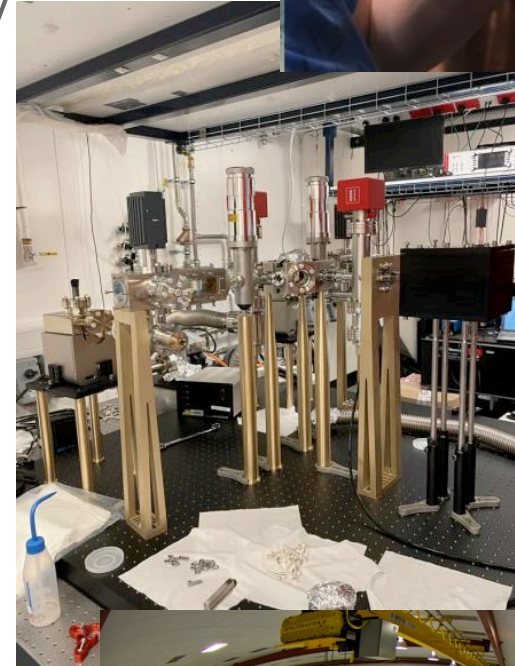

Engineering and  
Physical Sciences  
Research Council



Science and  
Technology  
Facilities Council

# QTFP Funding

The QTFP Programme has invested over £39m in 7 large consortia and 17 smaller projects.

## Large consortia

- AION: A UK Atom Interferometer Observatory and Network
- QI: Quantum-enhanced Interferometry for New Physics
- QUEST-DMC: Quantum Enhanced Superfluid Technologies for Dark Matter and Cosmology
- QSHS: Quantum Sensing for the Hidden Sector
- QSNET: A network of clocks for measuring the stability of fundamental constants
- QSimFP: Quantum Simulators for Fundamental Physics
- QTNM: Determination of Absolute Neutrino Mass Using Quantum Technologies



# Examples of International Working

**QTFP provides an opportunity for increasing international cooperation**

- Atom Interferometry Observatory and Network – MAGIS (Fermilab)
- Determination of Absolute Neutrino Mass Using Quantum - Project 8 Collaboration
- Quantum Sensors for the Hidden Sector – ADMX
- Quantum Enhanced Interferometry for New Physics – Deutsches Elektronen-Synchrotron (DESY), Germany as well as collaborators across the US
- QSNET – Max-Planck Institute for Nuclear Physics, Germany
- Quantum Simulators for Fundamental Physics - project partners in Canada, Germany and Austria
- QUEST DMC – projects partners in US

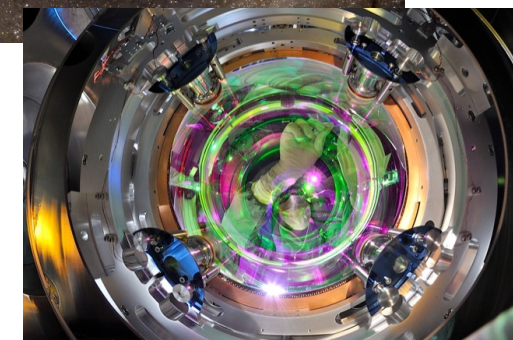
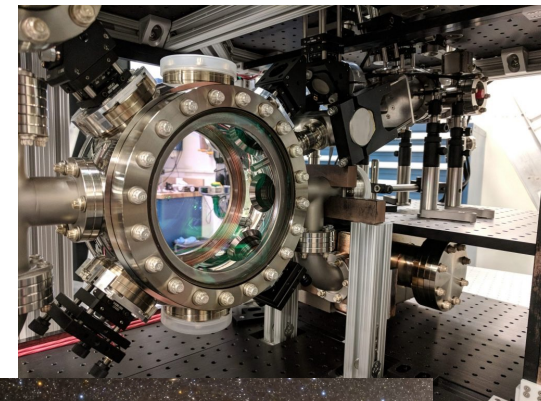

# International Science Partnership Fund

- QTFP related activities have been awarded through the International Science Partnerships Fund (ISPF) to support collaborations between UK researchers and innovators and their peers from around the world.
- Tranche 1 awards (£1.5m until FY 24/25):
  - **Quantum Software for a Digital Universe:** Collaboration between University of Edinburgh and UCSD to develop new quantum software to address fundamental physical questions.
  - **HiFAIS (High Flux Atom Interferometry Source):** Collaboration between RAL PPD/RAL Space and Stanford U. to develop new versions of a cold atom injector and quantum state preparation system.
- Tranche 3 awards (£4.55m until FY26/27):
  - 3-4 month **scientific exchange visits** awarded in FY 23/24. 14 grants awarded of which 10 are with the USA.
  - Pursuing discussions with Canada (NSERC, CFI) and USA (NSF, DOE) to fund collaborative activities starting in FY 24/25.



# Boulby Development

## New Facility

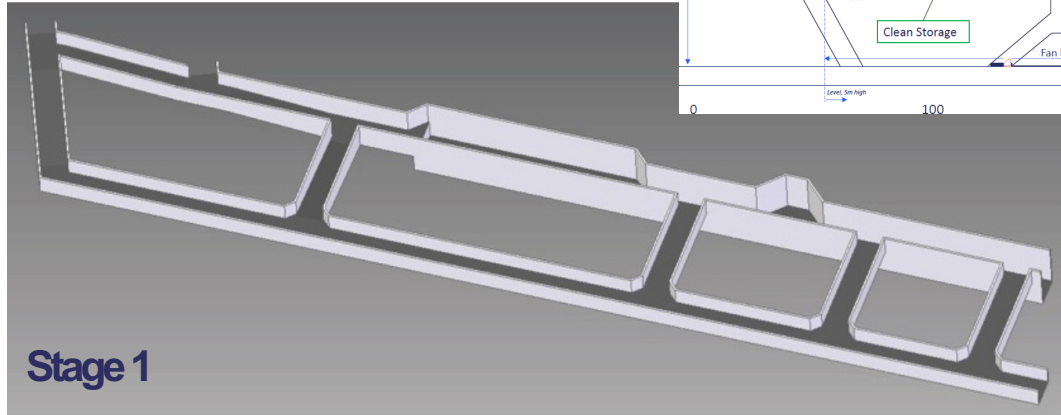
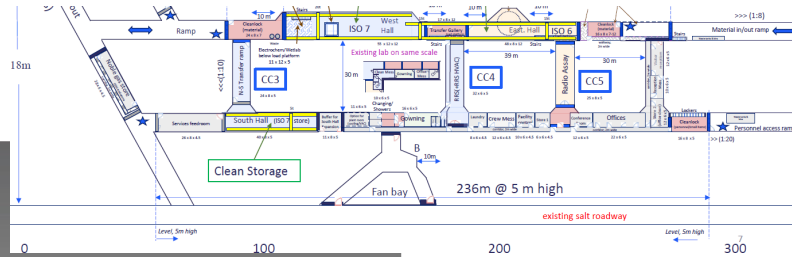

Stage 1

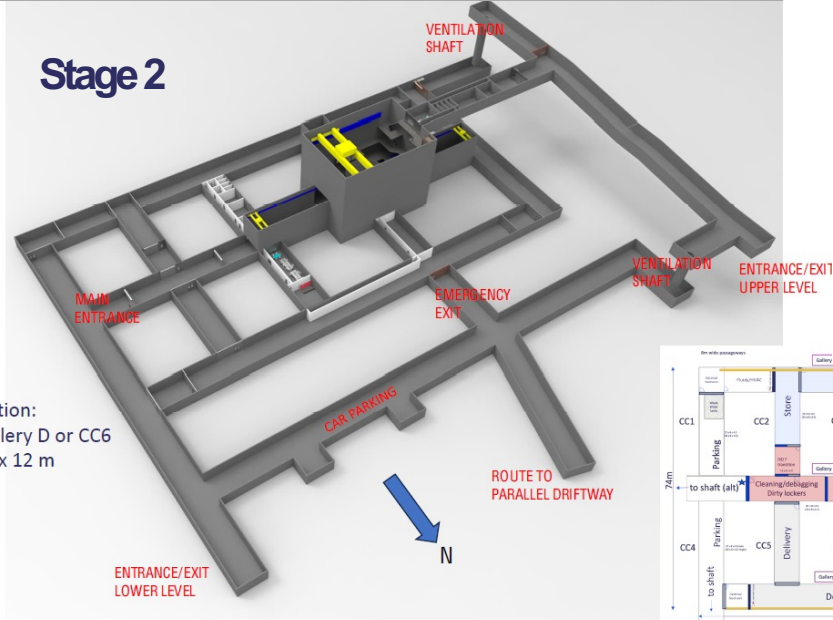

Option:  
Gallery D or CC6  
12 x 12 m

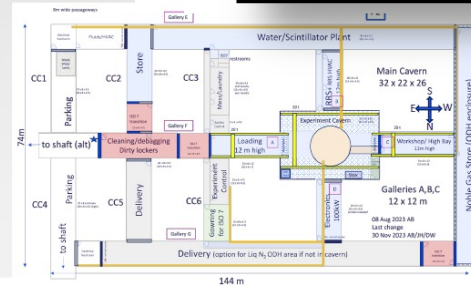

## BUTTON Technology Demonstrator





## Strategic Themes

## Objectives

## Deliverables

## 2035 Outcomes



### Ecosystem

STFC will expand support for development of quantum technologies in the UK. New and existing STFC facilities will be made available to convene research communities collaborating through STFC centres of excellence, lab space, user resources, and test-beds.

- STFC expert network supports UK research excellence.
- A suite of unique capabilities [SBRI @ NQCC, low-temperature, cryo @ ASTeC etc.], driving international collaborations
- A Q cluster, co-locating industrial researchers driving collaboration and accelerated discovery.
- State-of-the-art Q & classical compute resources for academia and industry through on-prem and QCaaS.
- Enabling the researcher community to deliver scientific excellence through QT.

Work in progress!

- Trusted advisor to HMG on QT.
- STFC integration supports UK QT pipeline.
- Cutting edge, secure QT development.
- 1000 Q engineers trained and accredited
- 100 organisation Q cluster
- On premises QC HW capable of 1m coherent operations with error correction.
- STFC university researcher community becomes an expert user of QT



### Science & Discovery

To stimulate and deliver quantum ideas and capabilities to advance fundamental physics, sensing beyond classical limitations and quantum computing, driving a *UK circular economy for QT*.

- Open access to QC test beds for scientific research.
- Q Sensing for the very *small, large* or *difficult*.
- Materials refinement through measurement & modelling.
- Optical and satellite-based Q networking.
- Support for in-orbit-demonstrations of QT.
- Community of experts deploying QT for scientific challenge

- Next generation Q sensors for CERN and future particle detectors.
- Improved capabilities for dark matter and gravitational wave detection.
- Molecular modelling beyond current in-silico techniques.
- Satellite-mediated UK Q network.
- Higher yield QT fabrication through improved materials.

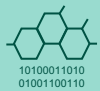

### Applications & Engagement

To drive commercial impact and societal good through accelerated adoption of *trusted* high performance research products and services with STFC support.

- A research-oriented QC user community.
- Supported industry adoption of QT.
- Energy, Healthcare & Space partner advantage through early adoption of QT.
- Acceleration of UKRI Net-Zero targets through the deployment of QT.
- Support research council adoption of QT.
- Integration of QC into UK HPC datacentres.

- 500 high impact research publications utilising STFC facilities, collaborations & partnerships.
- Significant IP portfolio of high-TRL QT.
- 75% UK user engagement across the 5 key industrial sectors served by QC.
- BBSRC, NERC etc. are informed QT users.
- UK quantum datacentres.



### Fabrication & Materials

To provide nanofabrication and characterisation alongside process engineering, measurement and modelling capabilities for future impact, revolutionising materials and device deployment into quantum technologies.

- Diagnostic, test and characterisation of QT hardware. using state-of-the art equipment and techniques.
- Nano-fabrication of novel materials and devices for QT.
- Process engineering improving yield, quality and performance to scale QT hardware leveraging STFC strength in materials science.

- Clean-room facilities supporting semi-conductors, photonics, superconducting films
- Metrology and QA supporting UK industry needs for quantum device production
- Optimisation of classical technologies delivering quantum applications
- Scaling QT through ASIC, control and systems integration.

# Some Reflections for STFC

- Correct balance between ‘fundamental’, ‘applied’, and ‘societal’ aspects of QT
  - These are interlinked in complex ways
- Lab-to-lab collaboration an enabler of our wider communities
  - Emphasis on new capabilities and user facilities
- Exemplar large-scale ‘grand challenge’ projects
  - Needed to push the envelope of quantum deployment
- Vast technological landscape
  - Cannot cover all technologies or approaches
  - International complementarity will be important
- Links to industry should be baked in
  - As suppliers, collaborators, and route to commercialization
- Exploit existing strengths in cryogenics, computing, SRF, DAQ, low-background technologies

# Potential opportunities for collaboration

- **Strand 1: Basic QT research aligned with SQMS programme, building on existing UK collaborations**
  - Example: decoherence time studies including effects of backgrounds.
  - Reciprocal access to SQMS and UK facilities by university and lab researchers
- **Strand 2: Technical developments towards practical QC, including control, readout and feedback**
  - Example: builds upon current collaboration with NQCC in QICK, etc. Could involve industry
- **Strand 3: QTFP, building on MAGIS / AION investment but with an expanded scope into other areas**
  - Target a combination of long-term and short-term science 'wins', at a range of scales and risk
- **Strand 4: User facilities, including novel facilities for microkelvin work and background-free tests**
  - Target international complementarity, with reciprocal access for international researchers to UK and vice versa
- **Strand 5: Quantum computing applications in fundamental science**
  - Example: Quantum enablement of theory calculations, as an exemplar and route to further engagement





Science and  
Technology  
Facilities Council



# Building the Ecosystem

*STFC will expand support for development of quantum technologies in the UK. New and existing STFC facilities will be available to convene research communities collaborating through STFC centres of excellence, lab space, user resources, and test-beds.*

- STFC Quantum leadership
- STFC QT project portfolio
- Build STFC skills base
- User facilities & incubation
- Test-beds, verification
- Trusted advice
- Technology roadmapping

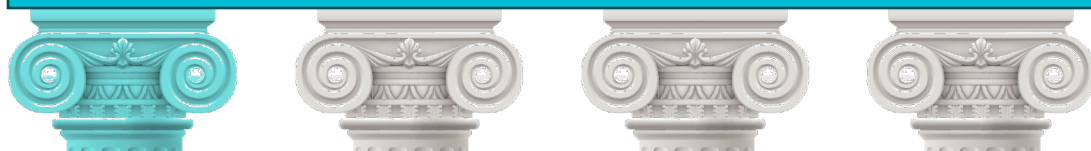

## → 2035 Vision

STFC is an integral part of UK R&D across quantum technologies, delivering the people, places, ideas and innovation focussed benefits of transformative QT.

- Trusted advisor to HMG on QT.
- User facilities supporting QT R&D. Cutting edge, secure QT development @ STFC.
- 1000 engineers trained and accredited
- 100 organisation quantum cluster
- On premises QC HW capable of 1m coherent operations with error correction.
- QTFP steering toward quantum sensing.
- STFC university researcher community becomes an expert user of QT

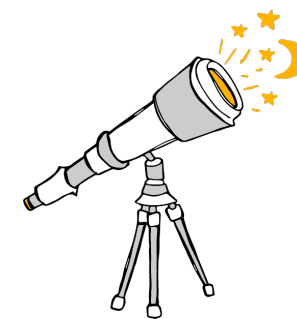



# Science and Discovery

*To stimulate and deliver quantum ideas and capabilities to advance fundamental physics, sensing beyond classical limitations and quantum computing, driving a UK circular economy for QT.*

- Quantum computing
- Quantum sensing
- Materials design & modelling
- QT for particle physics
- Delivery of QT to space



## → 2035 Vision

STFC is recognised global leader in quantum computing and quantum sensing. Coherent funding mechanisms and project portfolio drive continuous improvement across TRLs.

- Next generation Q sensors for CERN and future particle detectors.
- Improved capabilities for dark matter and gravitational wave detection.
- Molecular modelling beyond current in-silico techniques.
- Satellite-mediated UK Q network.
- Higher yield QT fabrication through improved materials.

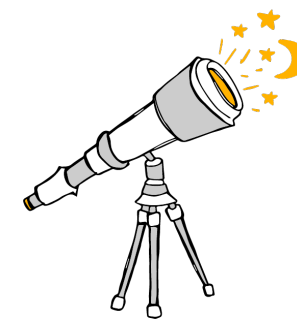





# Applications and Engagement

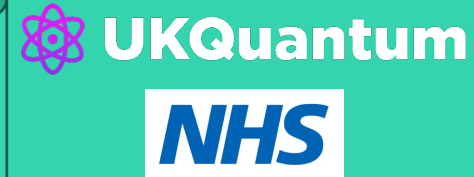

*To drive commercial impact and societal good through accelerated adoption of trusted high performance research products and services with STFC support.*

- Supported QT access for early adopters
- Applications development
- User engagement
- Engage research communities
- Significant IP portfolio
- Dissemination of best-practice

## → 2035 Vision

STFC leads the UK in quantum technology applications development, working with academia, business and the public to bring early impact to business, research communities and wider public good.

- 75% UK user engagement across the 5 key industrial sectors served by QC.
- 500 high impact research publications utilising STFC facilities, collaborations & partnerships.
- Significant IP portfolio of high-TRL QT.
- BBSRC, NERC etc. are informed QT users.
- QCaaS through UK quantum datacentres.



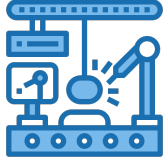

# Materials and Fabrication

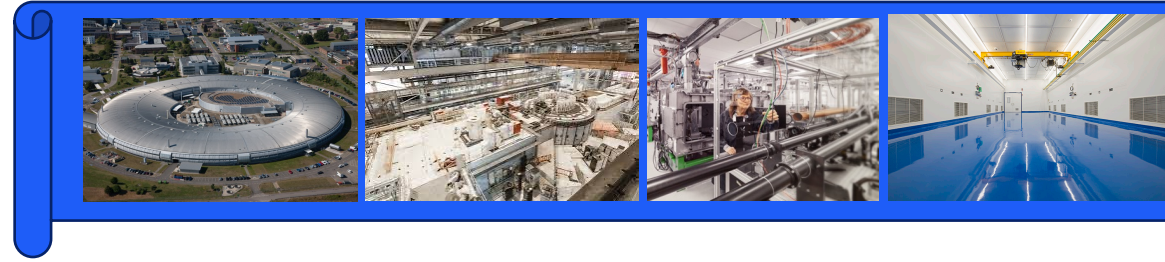

*To provide nanofabrication and characterisation alongside process engineering, measurement and modelling capabilities for future impact, revolutionising materials and device deployment into quantum technologies.*

- Drive design, manufacture & analysis of new QT materials
- Clean-room fabrication facilities
- Resolve engineering bottlenecks
- Scaling & integration for QT
- Improve QT yield

## → 2035 Vision

STFC drives development of materials for quantum technologies, including materials design and fabrication, high yield processes and engineering for quantum technologies.

- Clean-room facilities supporting semi-conductors, photonics, superconducting films
- Metrology and QA supporting UK industry needs for quantum device production
- Optimisation of classical technologies delivering quantum applications
- Scaling QT through ASIC, vacuum, control and systems integration.
- Large-scale facilities prioritise quantum technologies

