



Longitudinal Beam Diagnostics

10 – 22 November 2024

Spa, Belgium

L. Bobb, Diamond Light Source, UK

- Longitudinal beam profile in accelerators
- Invasive and Non-invasive techniques
 - Explain concepts
 - Review performances and limitations

Accelerating charged particles

Acceleration techniques

DC Accelerator



RF Accelerator



synchronizing particle
with an
electromagnetic wave!

Acceleration techniques

RF Accelerating structures

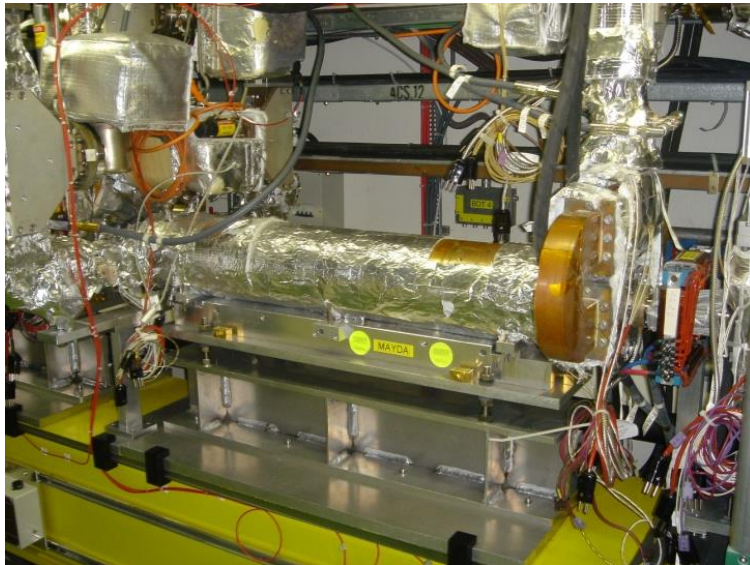
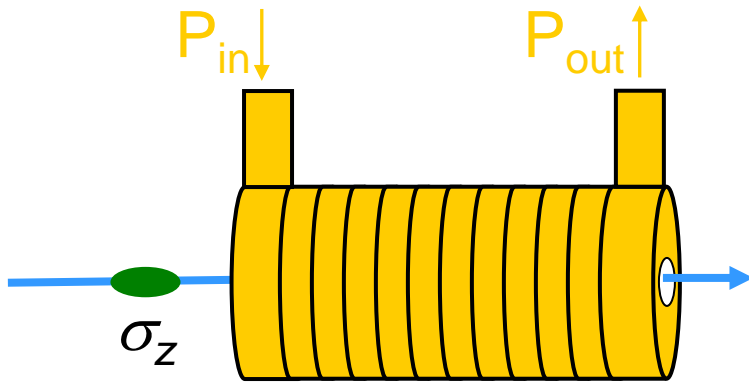

RF Accelerating Field

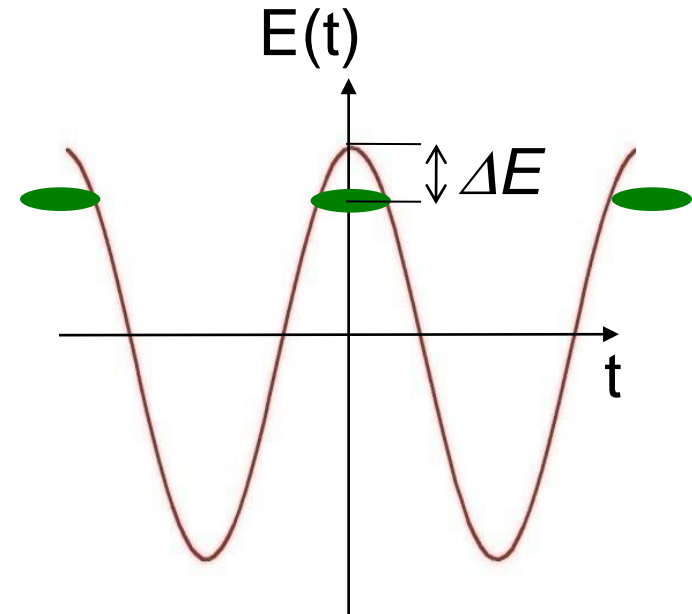

At 3GHz accelerating frequency

1 period = 333ps : Bunch spacing
 Typical bunch length : few deg ~ few ps

Accelerating cavities



CERN PS 19 MHz Cavity (prototype 1966)



400MHz LHC Cavity in its cryo-module

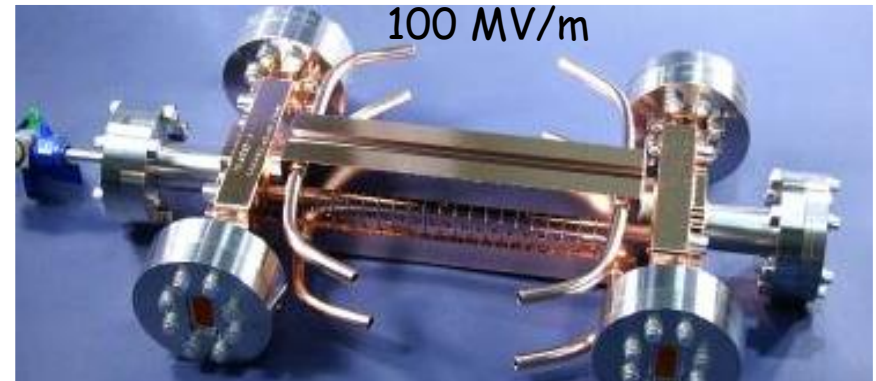
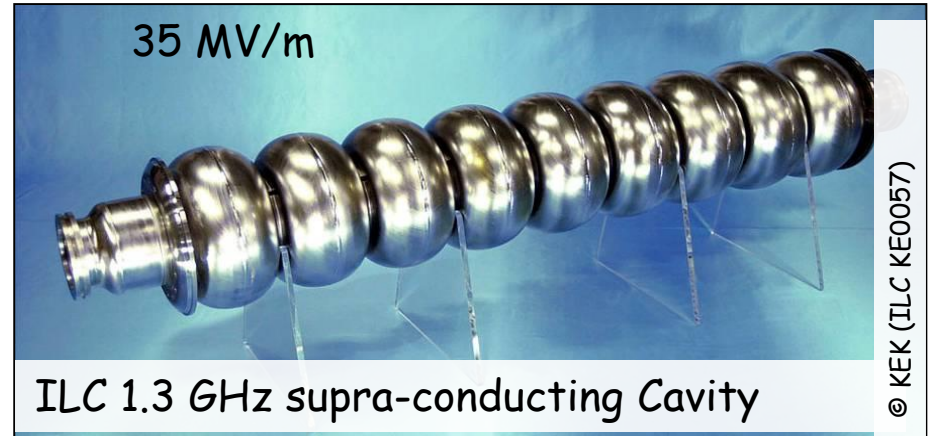

Dielectric Wakefield Acceleration



ARTICLE

Received 10 Mar 2016 | Accepted 29 Jul 2016 | Published 14 Sep 2016

DOI: 10.1038/ncomms12763 OPEN

Observation of acceleration and deceleration in gigaelectron-volt-per-metre gradient dielectric wakefield accelerators

B.D. O'Shea^{1,2}, G. Andonian¹, S.K. Barber¹, K.L. Fitzmorris¹, S. Hakimi¹, J. Harrison¹, P.D. Hoang¹, M.J. Hogan², B. Naranjo¹, O.B. Williams¹, V. Yakimenko² & J.B. Rosenzweig¹

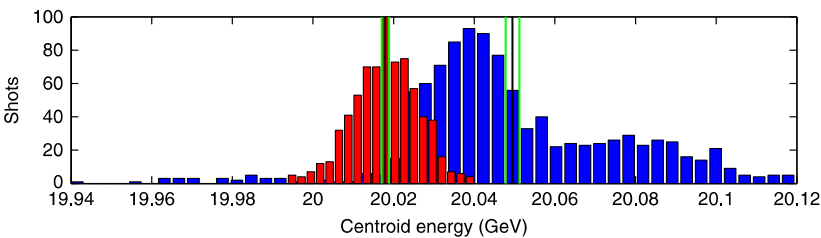
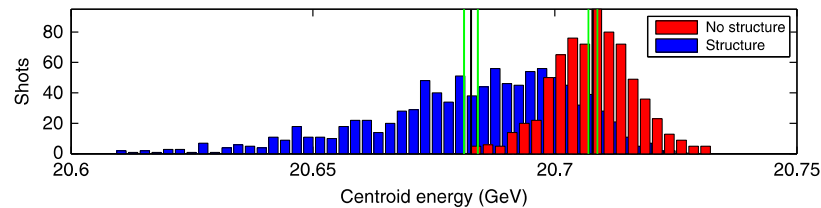
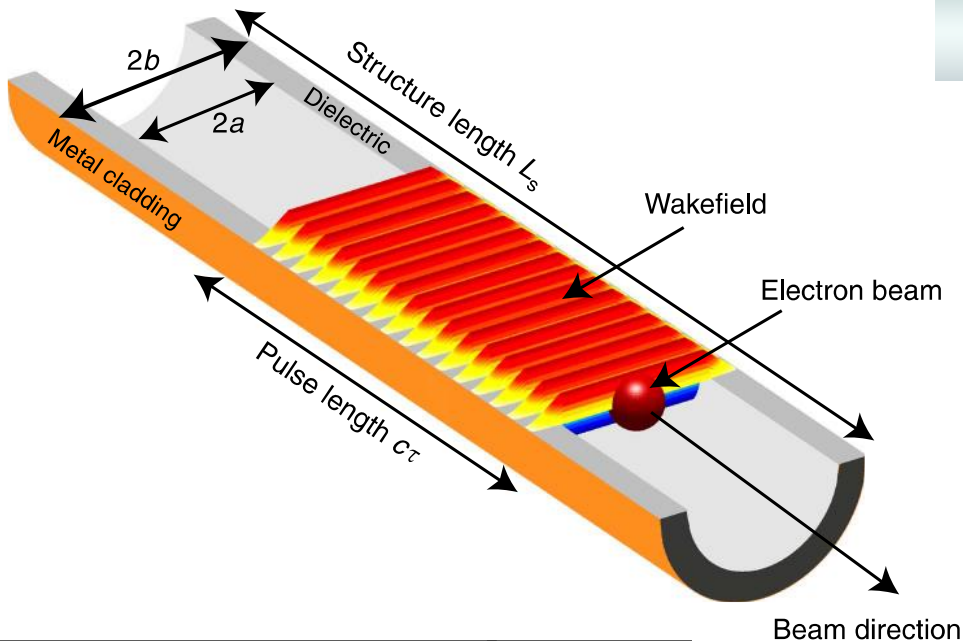

SiO₂ - 15cm long dielectric

Outer diameter : 2b-400um

Inner diameter : 2a-300um

Beam size 30um

Bunch length 25um (W) and 55um (D)

$\Delta t (D-W) = 250um - 833fs$

Laser Plasma Wakefield Acceleration

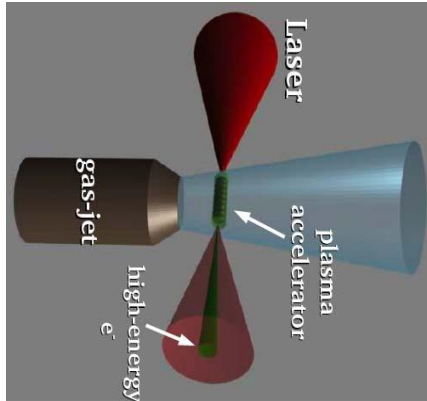

Courtesy of W. Mori & L. da Silva

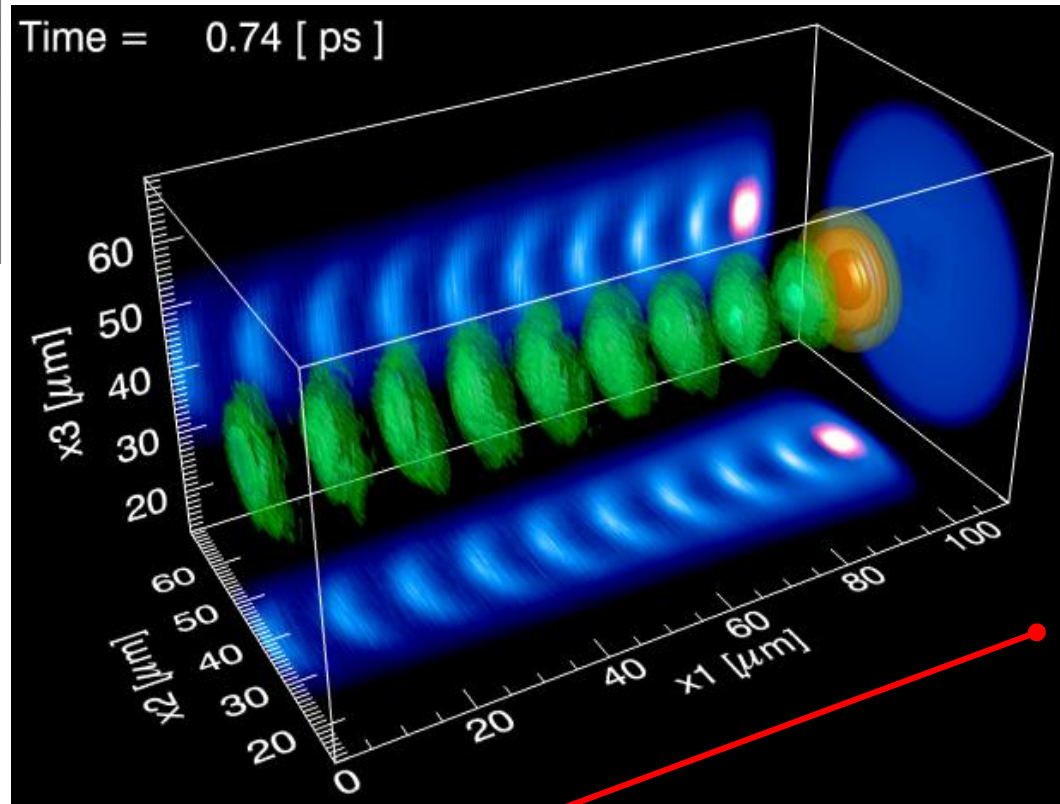

100 μm



LETTER

doi:10.1038/nature13882

High-efficiency acceleration of an electron beam in a plasma wakefield accelerator

M. Litos¹, E. Adli^{1,2}, W. An³, C. I. Clarke¹, C. E. Clayton⁴, S. Corde¹, J. P. Delahaye¹, R. J. England¹, A. S. Fisher¹, J. Frederico¹, S. Gessner¹, S. Z. Green¹, M. J. Hogan¹, C. Joshi⁴, W. Lu⁵, K. A. Marsh⁴, W. B. Mori³, P. Muggli⁶, N. Vafei-Najafabadi⁴, D. Walz¹, G. White¹, Z. Wu¹, V. Yakimenko¹ & G. Yocky¹

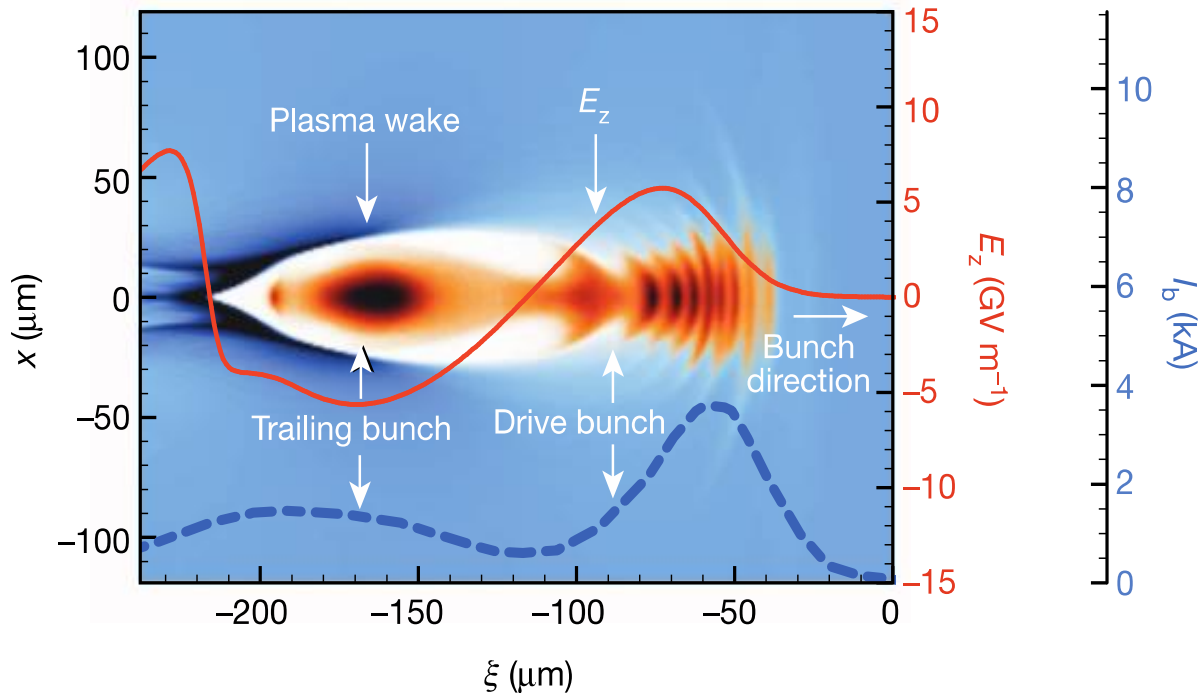

Typical bunch length

H ⁻ @ SNS	100ps
H ⁺ @ LHC	230ps
e ⁻ @ DLS	20ps
e ⁻ @ CLIC	130fs
e ⁻ @ XFEL	10fs
e ⁻ @ DWFA	<60fs
e ⁻ @ PWFA	<30fs
e ⁻ @ LWFA	<10fs

Bunch length measurement techniques

Bunch length measurement techniques

Radiative techniques

Optical Method

1. Produce visible light
2. Analyse the light pulse using dedicated instruments

Bunch Frequency Spectrum

The shorter the bunches, the broader the bunch frequency spectrum

RF manipulation

Use RF techniques to convert time information into transverse information

Laser-based beam diagnostic

Using short laser pulses and sampling techniques

Bunch length measurement techniques

1- Longitudinal Profile



RMS or FWHM values

- *More precise information on the beam characteristic*

2- Single shot measurements



Sampling measurements

- *Do not care about the beam reproducibility*
- *No additional problem due to timing jitter*

3- Non-invasive



Destructive Devices

- *Can be used for beam study and beam control for on-line monitoring*
- *Beam Power density : No risk of damage by the beam itself*

Bunch length measurement techniques

Do not forget about **Simplicity and Reliability**

‘Beam diagnostics should help you to understand the beam properties, **it should not be the opposite**’



A detector, what for ?

- Online Beam stability → Non-intercepting and **reliable**
Only have access to a partial information (RMS values)
- Beam characterization and beam physics study → **Full information**
Complexity and time consuming

Bunch length measurement techniques

Can we perform non-invasive, single shot, beam profile measurement in an easy way ?

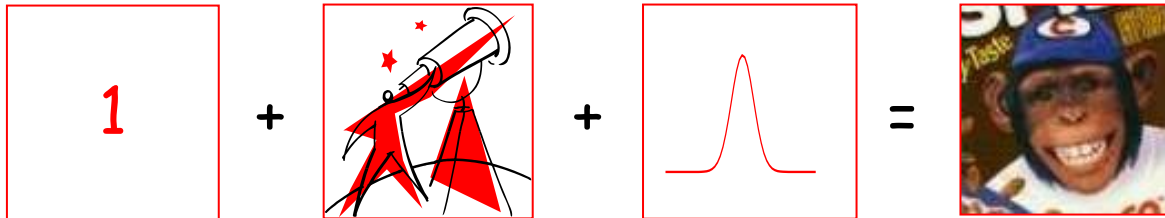

Radiative techniques

‘Converting particles into photons’

Incoherent versus Coherent Radiation

At wavelength much shorter than the bunch length, the radiation is emitted incoherently because each particle emits photon independently from the others without a defined phase relation

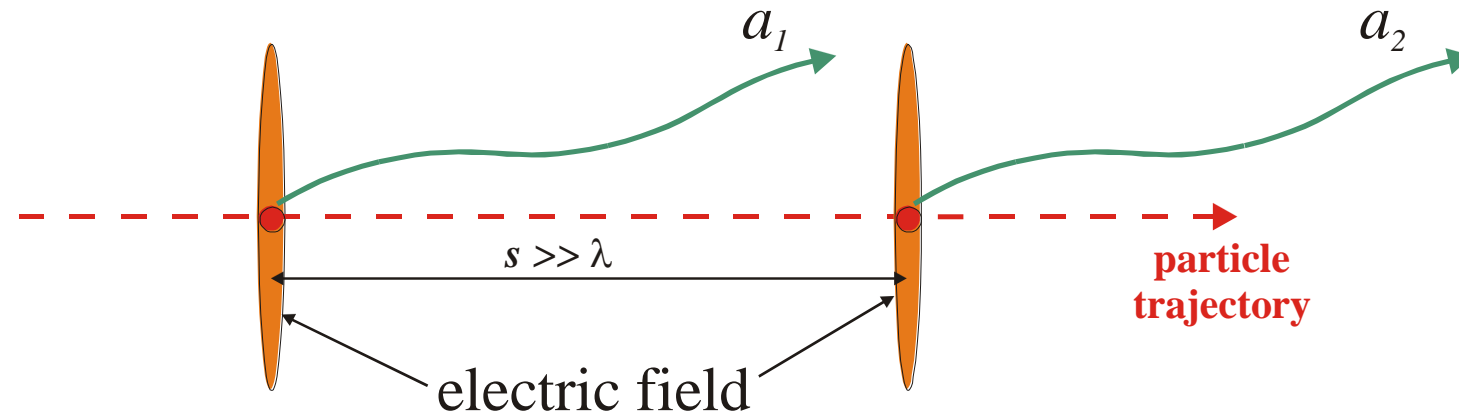

$$I = |a_1|^2 + |a_2|^2 = 2|a|^2 \rightarrow N|a|^2$$

Incoherent radiation

Incoherent versus Coherent Radiation

A coherent enhancement occurs at wavelengths which are equal to or longer than the bunch length, where fixed phase relations are existing, resulting in the temporal coherence of the radiation

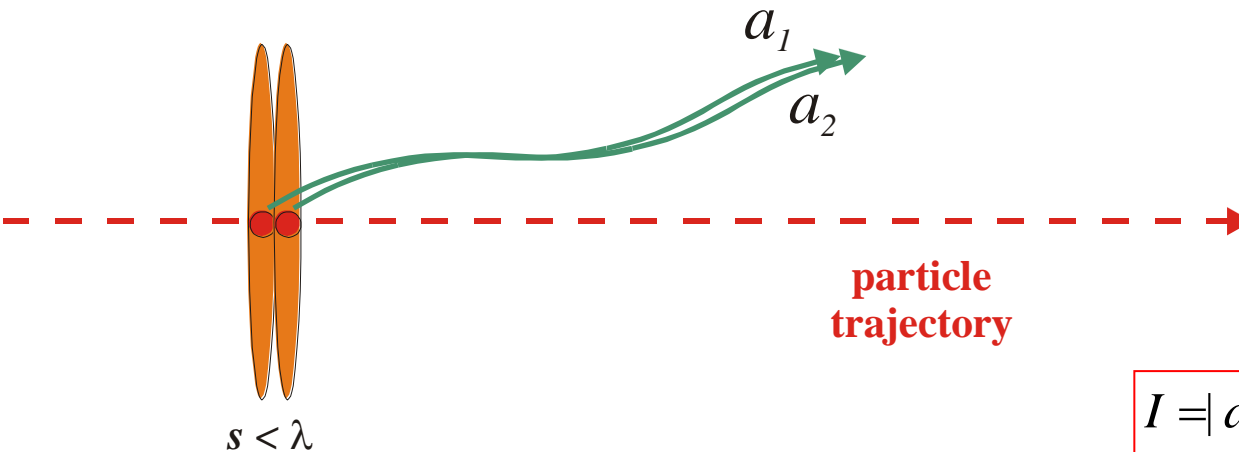

$$I = |a_1 + a_2|^2 = |2a|^2 = 4|a|^2 \rightarrow N^2 |a|^2$$

Coherent radiation

Total radiation spectrum

Incoherent term

Coherent term

$$S(\omega) = S_p(\omega) \left[N + N(N-1) F(\omega) \right]$$

$S(\omega)$ – radiation spectrum

$S_p(\omega)$ – single particle spectrum

N – number of electrons in a bunch

$F(\omega)$ – longitudinal bunch form factor

$$F(\omega) = \left| \int_{-\infty}^{\infty} \rho(s) e^{-i\frac{\omega}{c}s} ds \right|^2$$

$\rho(s)$ – Longitudinal particle distribution in a bunch

Radiative processes



- Transition radiation
- Cherenkov radiation

Better for $\gamma > 100$

$$\beta > 1/n$$



- Diffraction radiation
- Cherenkov Diffraction radiation
- Synchrotron radiation

For incoherent radiation
 $\gamma > 3000$

For coherent radiation
$$\gamma > \frac{0.06}{\sigma_z(m)}$$

Radiative processes



- Transition radiation
- Cherenkov radiation

Better for $\gamma > 100$

$$\beta > 1/n$$

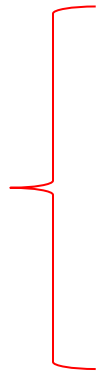

- Diffraction radiation
- Cherenkov Diffraction radiation
- Synchrotron radiation

For incoherent radiation
 $\gamma > 3000$

For coherent radiation
 $\gamma > \frac{0.06}{\sigma_z(m)}$

Optical method using Incoherent light

Time correlated single photon counting



Geiger-mode Avalanche photodiode converts photon to electrical pulse

Visible photon

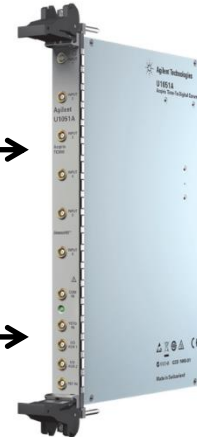
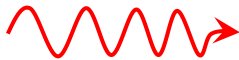

Time to Digital converter records pulse arrival time

Precise trigger synchronized with the beam



- Start/Stop timestamping of photons relative to trigger
- Sampling Method allowing very high dynamic range if you measure long enough
- Avalanche photodiode have deadtime and are subject to after-pulsing
- State of the art TDC typically limited to 10ps sampling

D.V. O'Connor, D. Phillips, Time-correlated Single Photon Counting, Academic Press, London, 1984

C.A. Thomas et al., Nucl. Instr. and Meth. A566 (2006) p.762

Time correlated single photon counting



Longitudinal profile of the entire LHC ring (89us) with 50ps resolution using SR light

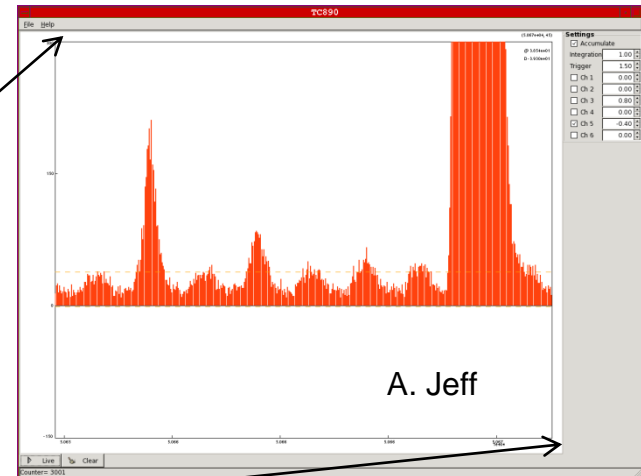
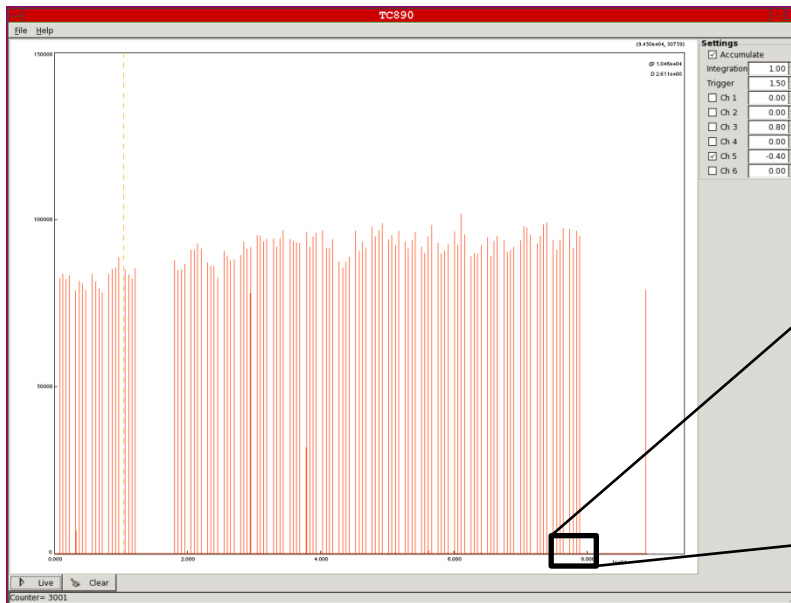

A very large dynamic range should make it possible to see ghost bunches as small as $5e5$ protons / 50ps with long integration

Streak Camera

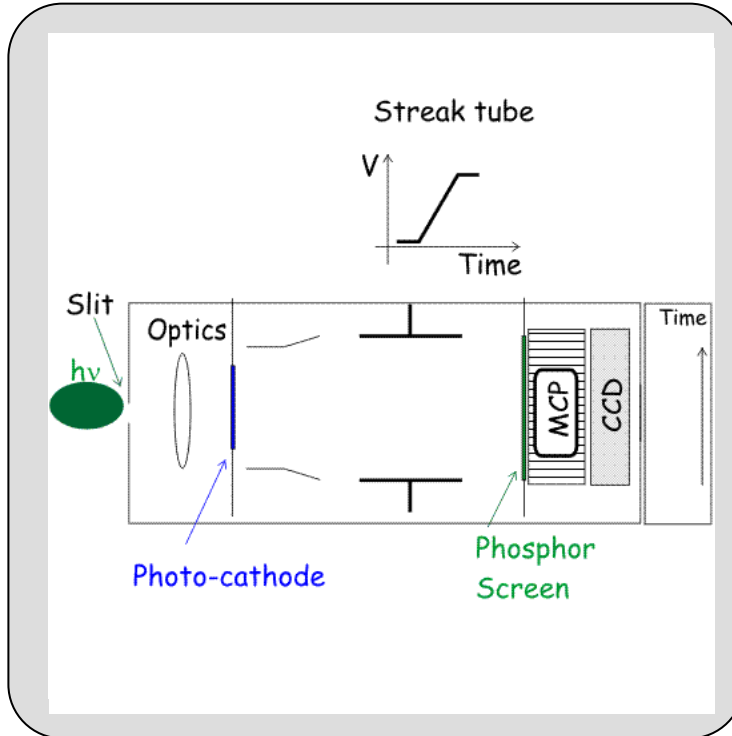

‘Streak cameras uses a time dependent deflecting electric field to convert time information in spatial information on a CCD’

M. Uesaka et al, NIMA 406 (1998) 371

200fs time resolution obtained using reflective optics and 12.5nm bandwidth optical filter (800nm) and the Hamamatsu FESCA 200

Limitations : Time resolution of the streak camera :

- (i) Initial velocity distribution of photoelectrons : *narrow bandwidth optical filter*
- (ii) Spatial spread of the slit image: *small slit width*
- (iii) Dispersion in the optics

Streak Camera

Observation of 5MeV electron bunch train using Cherenkov radiation
Sweep speed of 250ps/mm



1

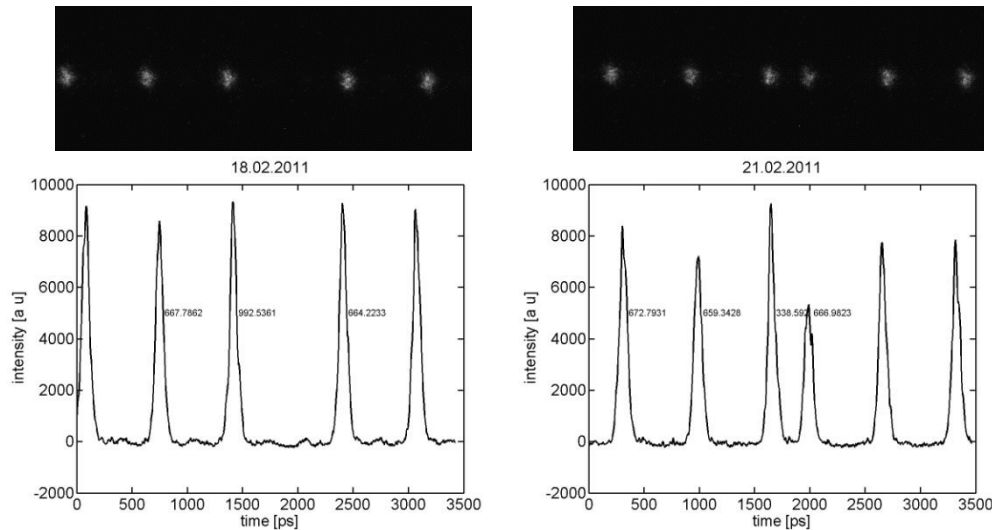

Measure of bunch length using OTR and OSR

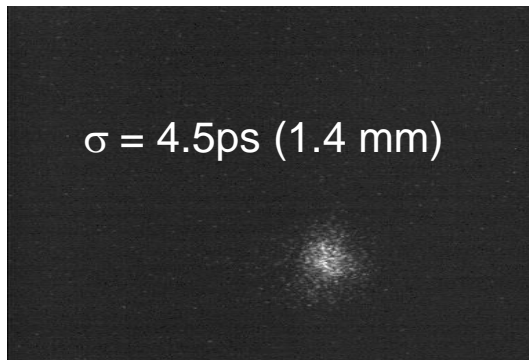

*Sweep
speed of
10ps/mm*

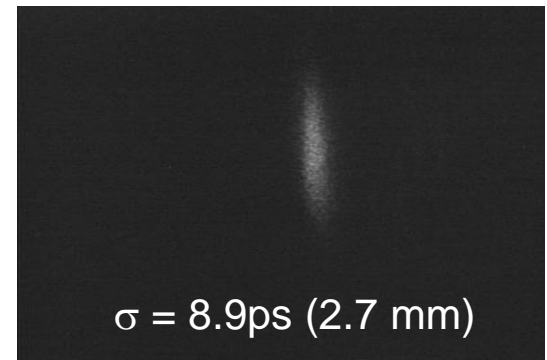

Bunch length measurement using using Coherent light

**‘The shorter in time the broader in
frequency’**

Bunch form factor

$$F(\omega) = \left| \int_{-\infty}^{\infty} dz \rho(z) e^{i(\omega/c)z} \right|^2$$

$$\rho(z) = \frac{1}{\pi c} \int_0^{\infty} d\omega \sqrt{F(\omega)} \cos\left(\frac{\omega z}{c}\right)$$

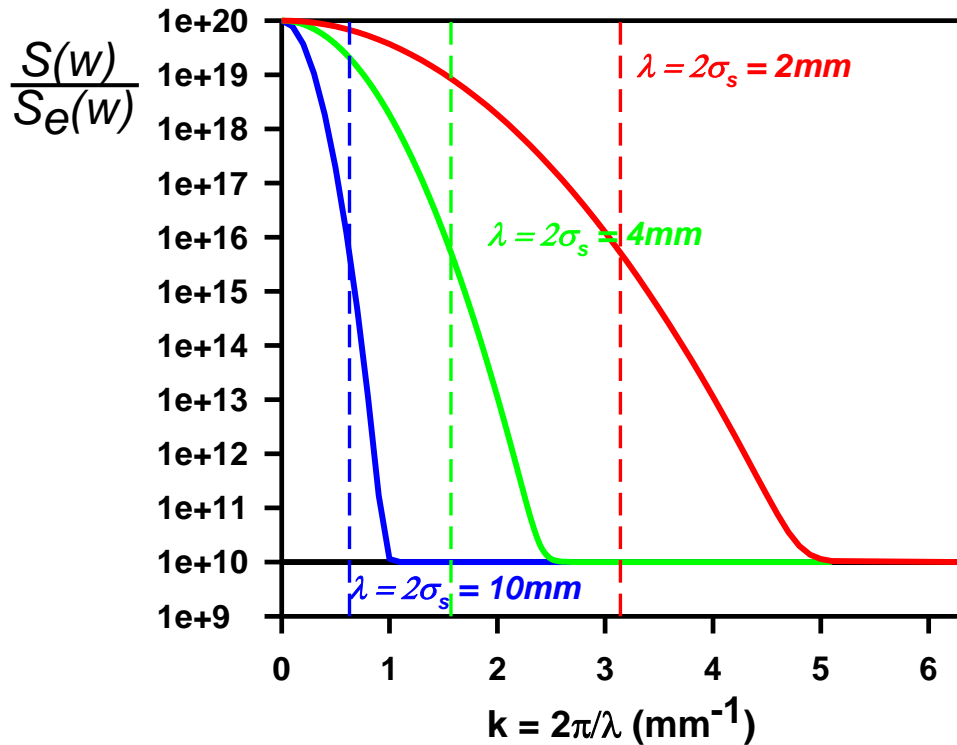

Coherent radiation appears when the bunch length is comparable to or shorter than the emitted radiation wavelength

Measuring the Radiation Spectrum

$$S(\omega) \gg N^2 S_p(\omega) F(\omega)$$

- ✓ $S(\omega)$ – radiation spectrum (known in the experiment)
- ✓ N – number of particles s / bunch (known from the experiment)
- ✓ $F(\omega)$ – bunch form factor (what you want to find out)
- ✓ $S_p(\omega)$ – single particle spectrum (should be known)



Coherent Transition Radiation (CTR)

P. Kung et al, **Physical review Letters** 73 (1994) 96



Coherent Diffraction (CDR) or Coherent Synchrotron (CSR)

B. Feng et al, **NIM A** 475 (2001) 492–497 ; A.H. Lumpkin et al, **NIM A** 475 (2001) 470–475

C. Castellano et al, **Physical Review E** 63 (2001) 056501

T. Watanabe et al, **NIM A** 437 (1999) 1-11 & **NIM A** 480 (2002) 315–327

Measuring the Radiation Spectrum

Frequency Domain

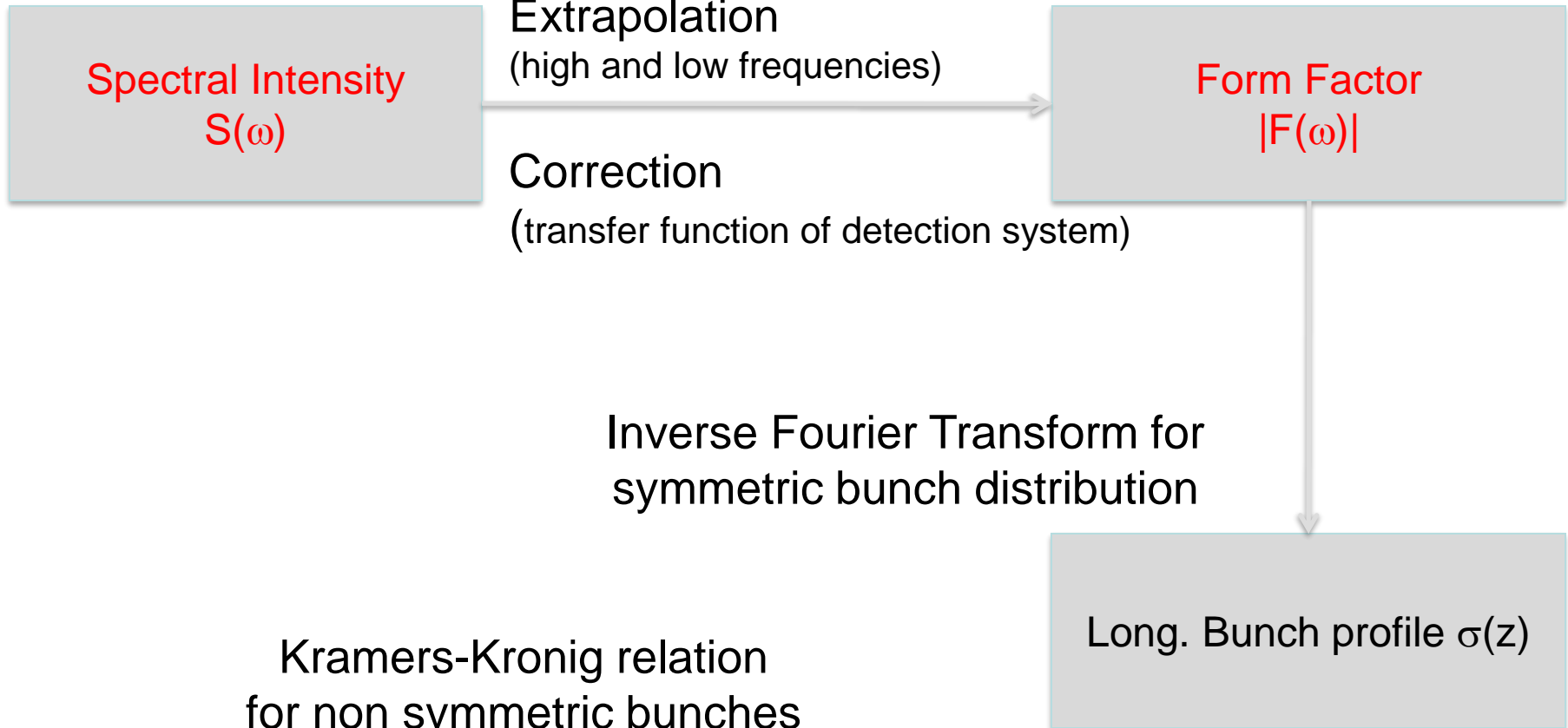

Kramers-Kronig relation
for non symmetric bunches

R. Lai and A.J. Sievers, NIM-A 397 (1997) 221 -231

Time Domain

Measuring the Radiation Spectrum

Frequency Domain

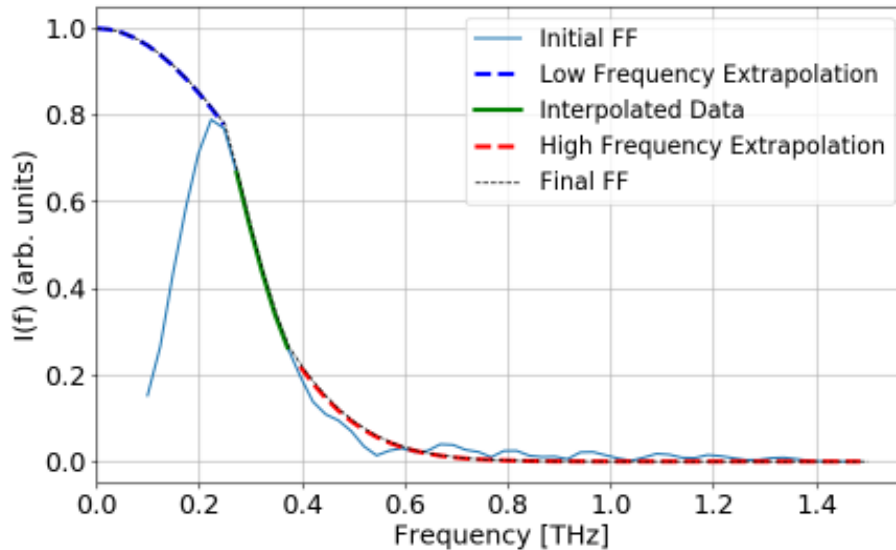

- Extrapolation
(high and low frequencies)
- Correction
(transfer function of detection system)

Inverse Fourier Transform using
Kramer kronig relation

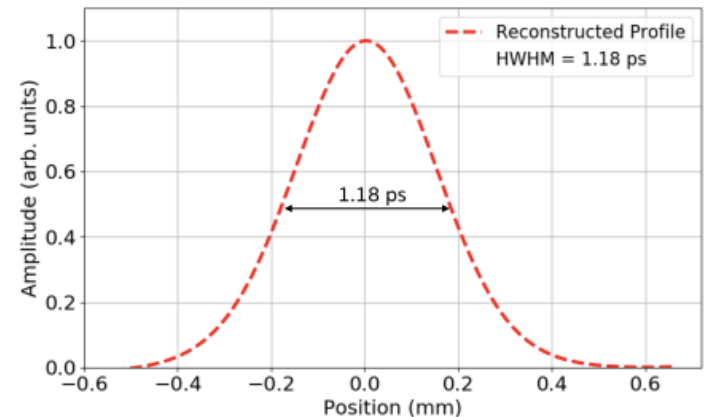

Time Domain

Measuring the Radiation Spectrum

1

*‘The **polychromator** enables to get the spectrum directly by a single shot. The radiation is deflected by a grating and resolved by a multi-channels detector array’*

T. Wanatabe et al., NIM-A 480 (2002) 315-327

H. Delsim-Hashemiet al., Proc. FLS, Hamburg 2006, WG512

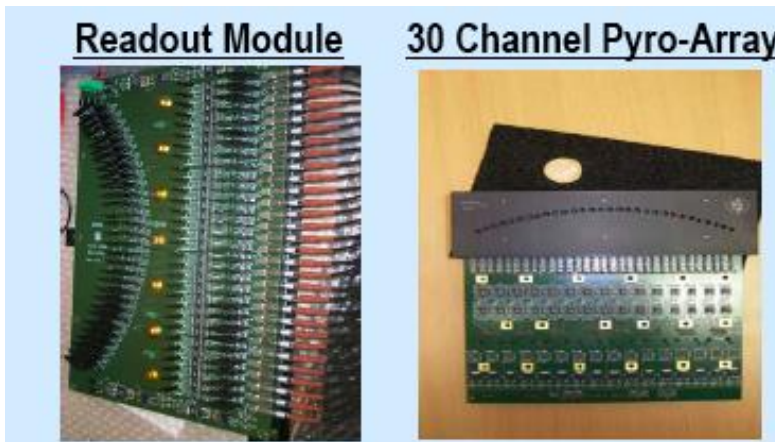
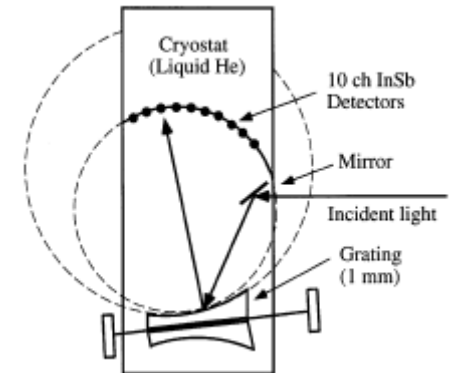

B. Schmidt, DESY

Measured & calculated spectra

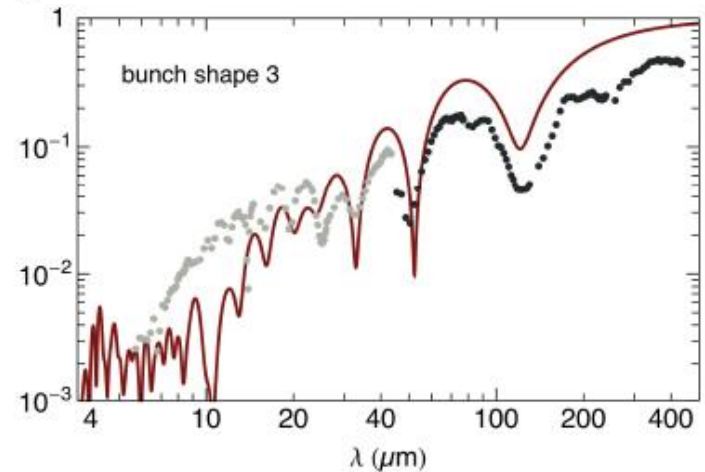

(E. Hass et al., Proc. SPIE 8778, May 2013)

Single shot CTR measurements

- T. J. Maxwell et al. "Coherent-radiation spectroscopy of few-femtosecond electron bunches using a middle-infrared prism spectrometer." *Physical review letters* 111.18 (2013)

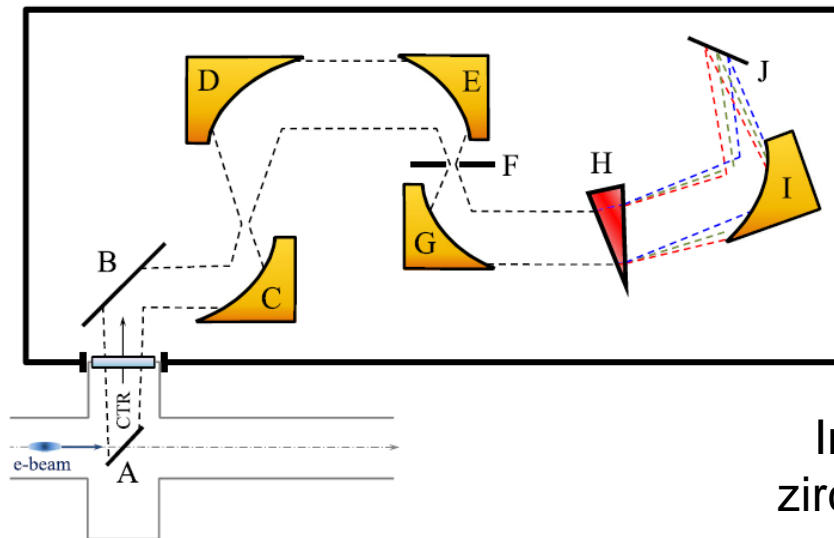

KRS-5 (thallium bromiodide) prism based spectrometer

Images CTR from foil onto 128 lead zirconate titanate pyroelectric elements with 100 μm spacing line array

1



Single-shot Cherenkov diffraction measurement



Cherenkov diffraction radiation
Measured in 3 bands (60-90-110GHz)

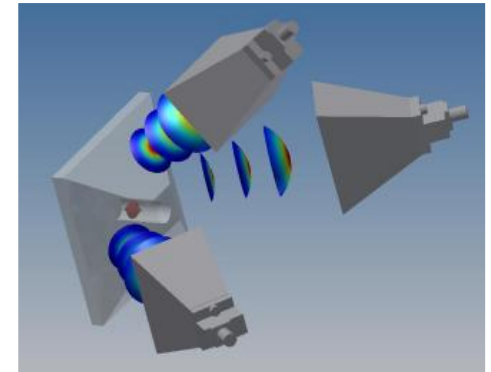

Pyramidal cone
with 1cm aperture

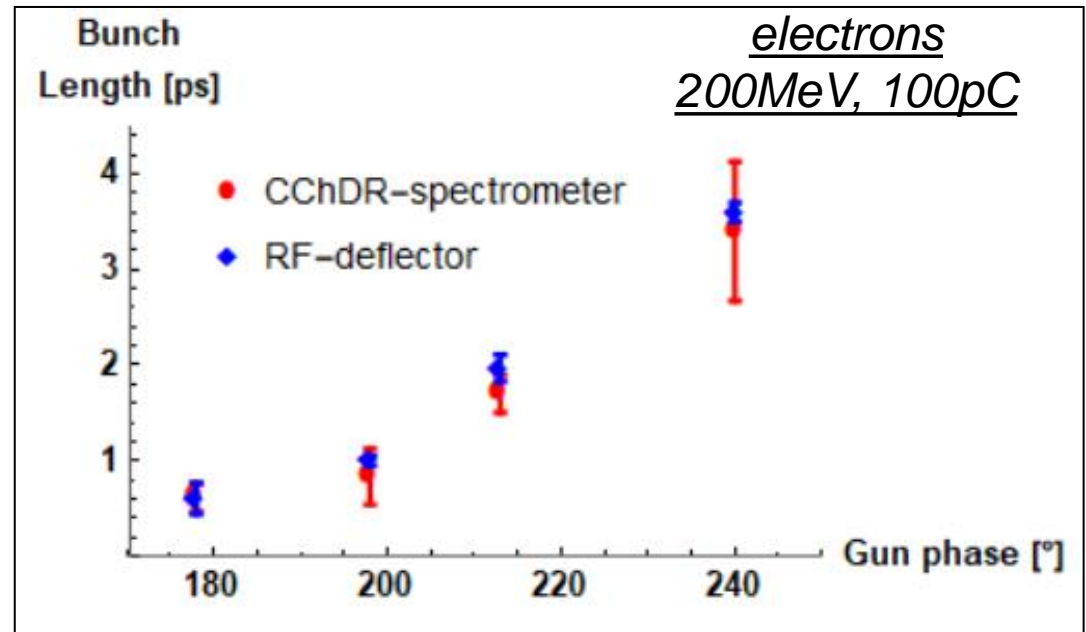
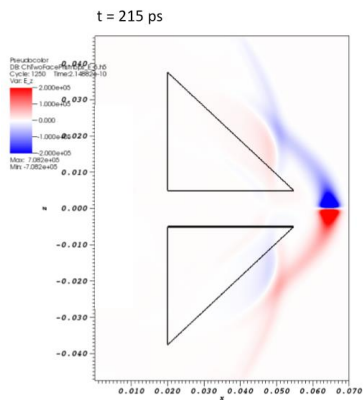
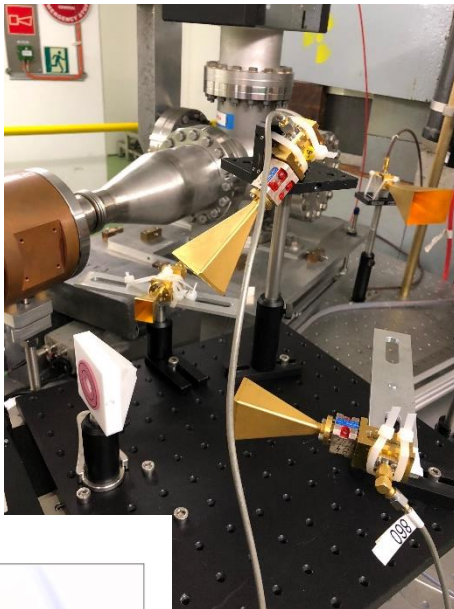

A. Curcio et al, PRAB 23 (2018) 022802

Radiofrequency manipulation

**‘How to transform time information
into spatial information’**

Bunch shape monitor

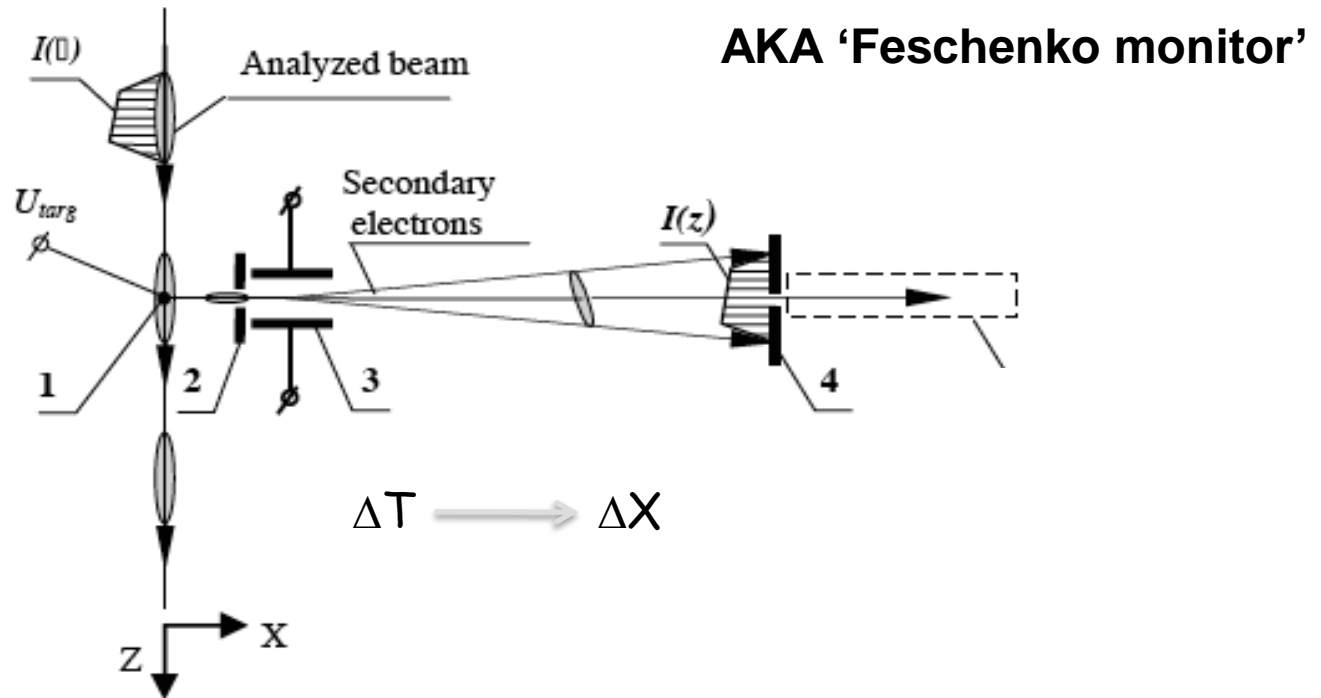
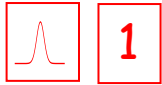

- 1 - Target (wire, screen, laser for H^-) : Source of secondary electrons
- 2 - Input collimator
- 3 - RF deflector (100MHz, 10kV) combined with electrostatic lens
- 4 - Electron Beam detector (electron multiplier, ..)

Bunch shape monitor

Longitudinal Bunch profile @ SNS

A. Feschenko *et al*, Proceedings of LINAC 2004, Lübeck, p408

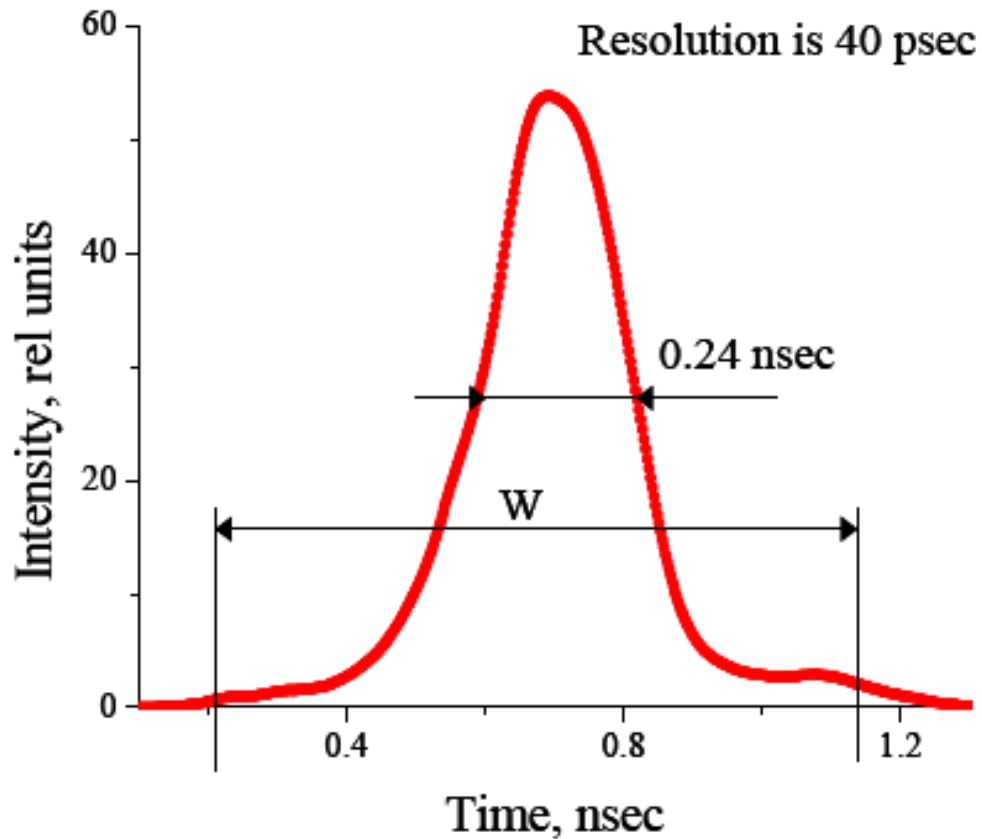

RF Deflecting cavities

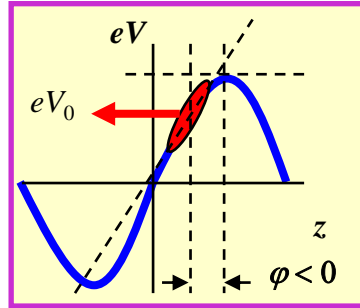
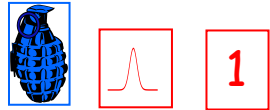

- Old idea from the 60's
- RF Deflector ~ relativistic streak tube

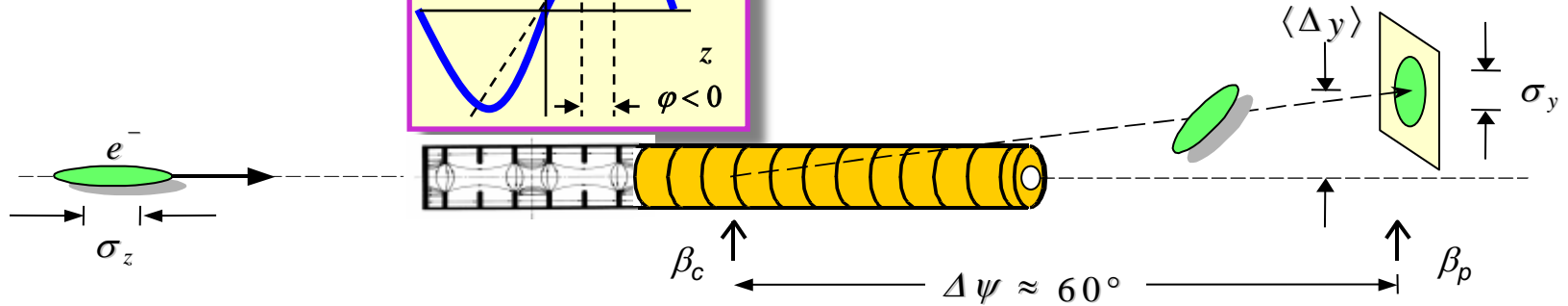

Beam profile RF on

$$\sigma_y = \sqrt{\sigma_{y_0}^2 + \sigma_z^2 \beta_c \beta_p \left(\frac{2\pi}{\lambda} \frac{eV_0}{E_0} \sin(\Delta\Psi) \cos(\varphi) \right)^2}$$

Deflecting Voltage: $\frac{2\pi}{\lambda} \frac{eV_0}{E_0}$
 RF deflector wavelength: λ
 Beam energy: E_0
 Betatron phase advance (cavity-profile monitor): $\sin(\Delta\Psi) \cos(\varphi)$
 Bunch length: σ_z
 Beta function at cavity and profile monitor: $\beta_c \beta_p$

$\sin\Delta\psi = 1, \beta_p$ small
Make β_c large

RF Deflecting cavities

CTF3

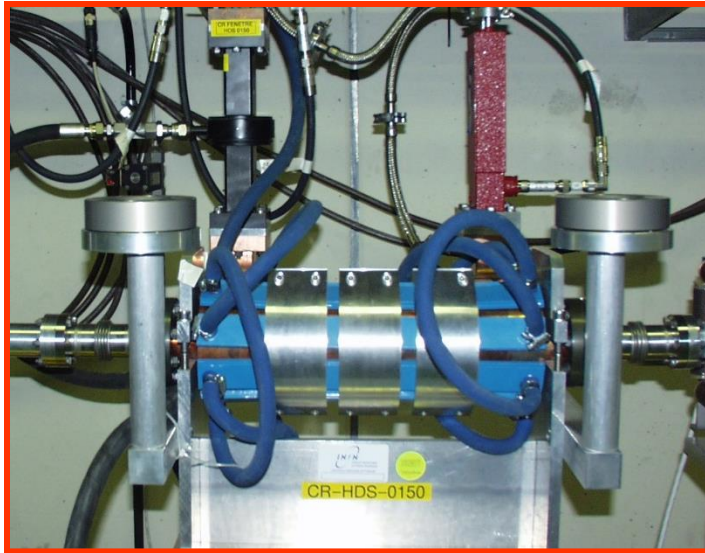

LOLA @ Flash

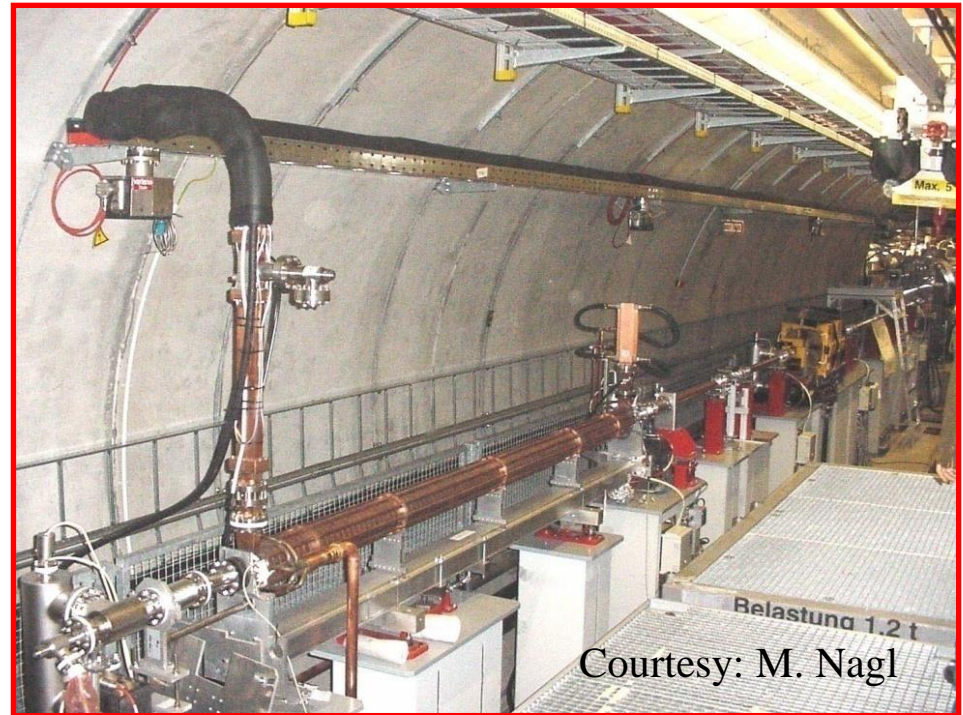

RF Deflecting cavities

Calibration of RF Deflector

$\Delta X(\text{mm}) \longrightarrow \Delta\varphi(^{\circ})$
 $\Delta T(\text{ps})$

Monitor the Beam Position on (or close to) the Profile monitor to calibrate the deflection angle

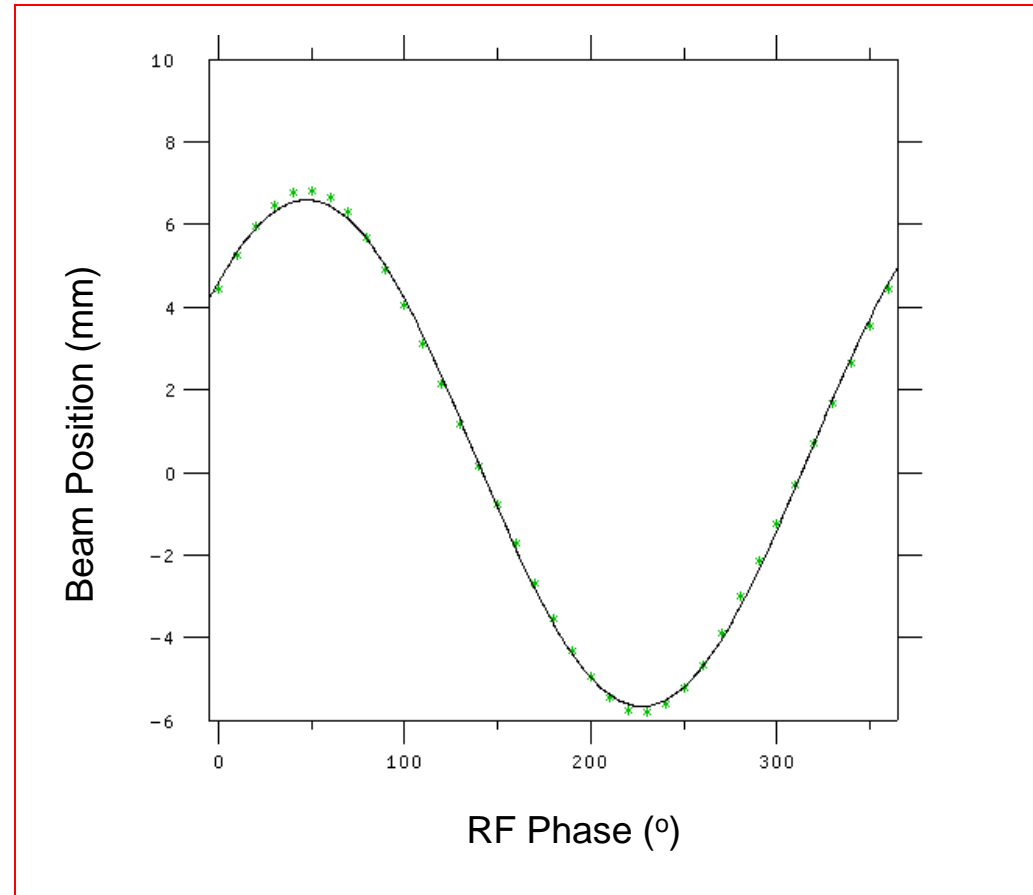

Beam offset on the screen

$$\Delta y(z) \approx \frac{eV_0}{E_0} \cdot \sqrt{\beta_c \beta_p} \sin(\Delta\Psi) \left(\frac{2\pi}{\lambda} - z \cos(\varphi) + \sin(\varphi) \right)$$

RF deflector phase

RF Deflecting cavities

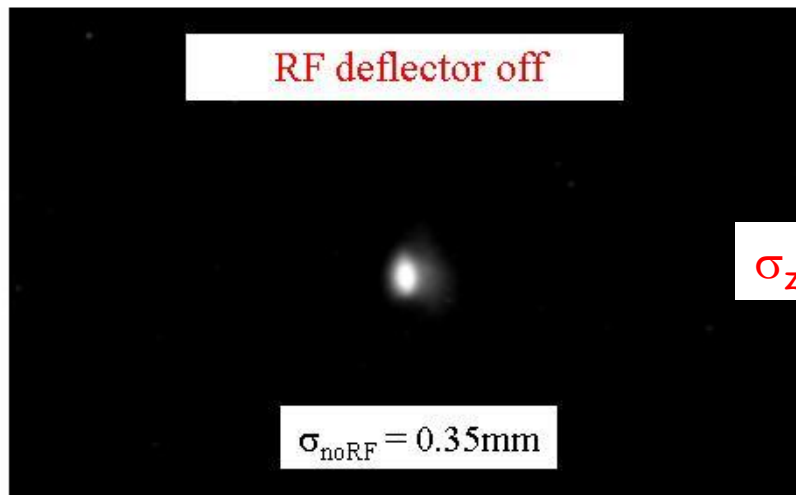
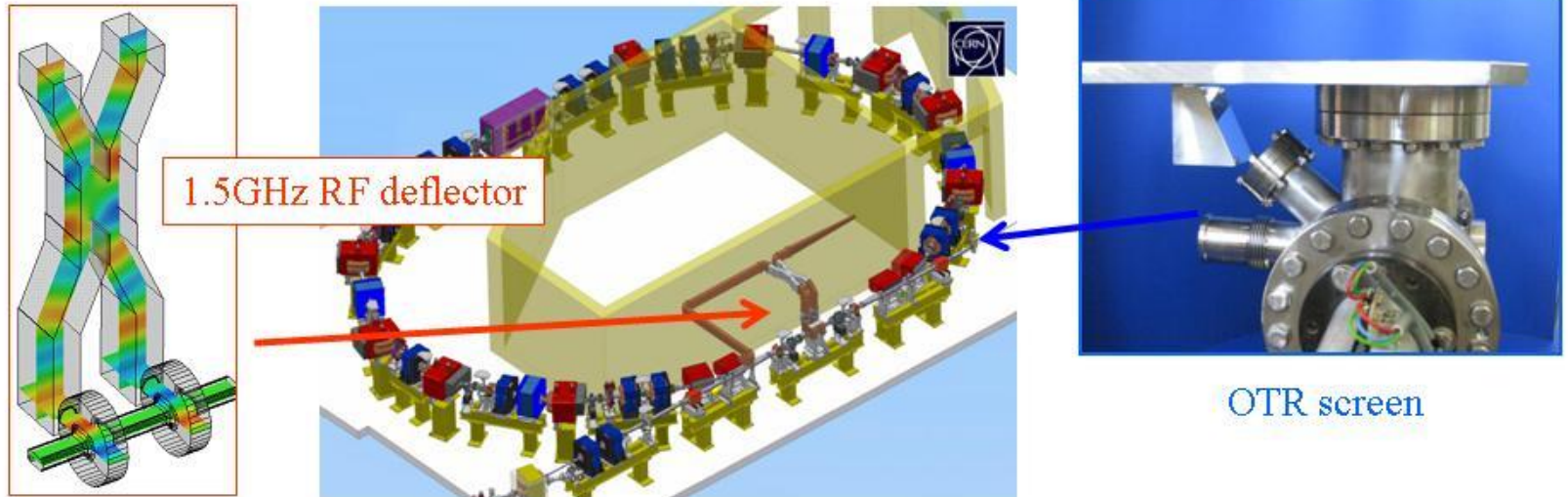

$\sigma_z = 2\text{ps}$

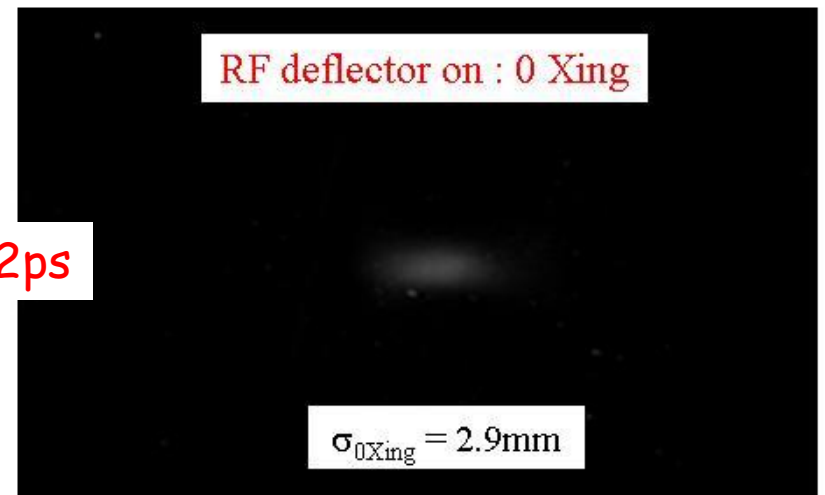

RF Deflecting cavities

Bunch length measurement @ Flash

M. Hüning *et al*, Proceeding of the 27th FEL conference, Stanford, 2005, pp538

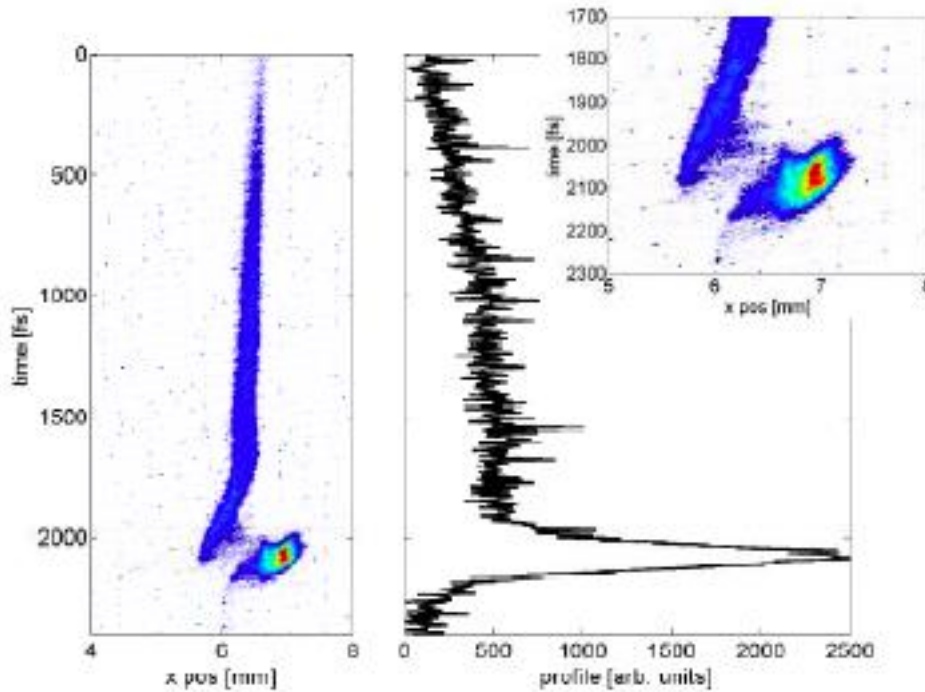

→ Resolution of 4fs/pixels

LOLA off:

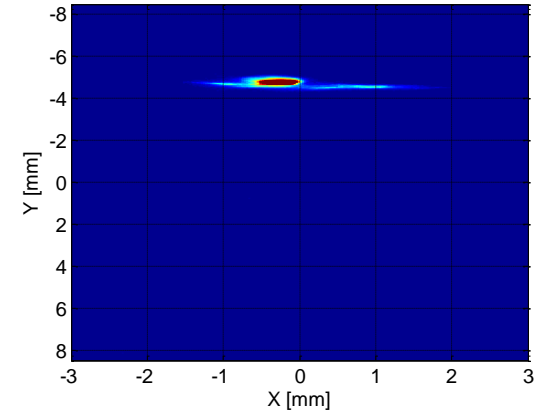

LOLA on:

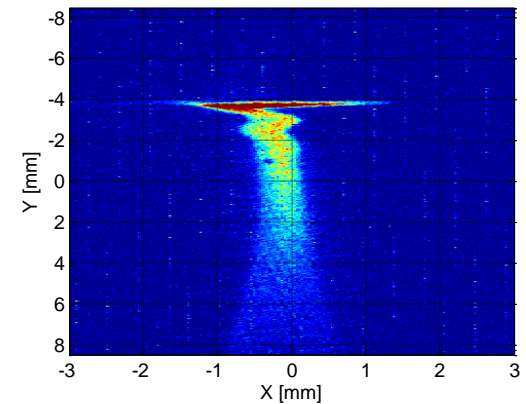

RF Accelerating cavities

'The electron energy is modulated by the **zero-phasing** RF accelerating field and the bunch distribution is deduced from the **energy dispersion** measured downstream using a spectrometer line'

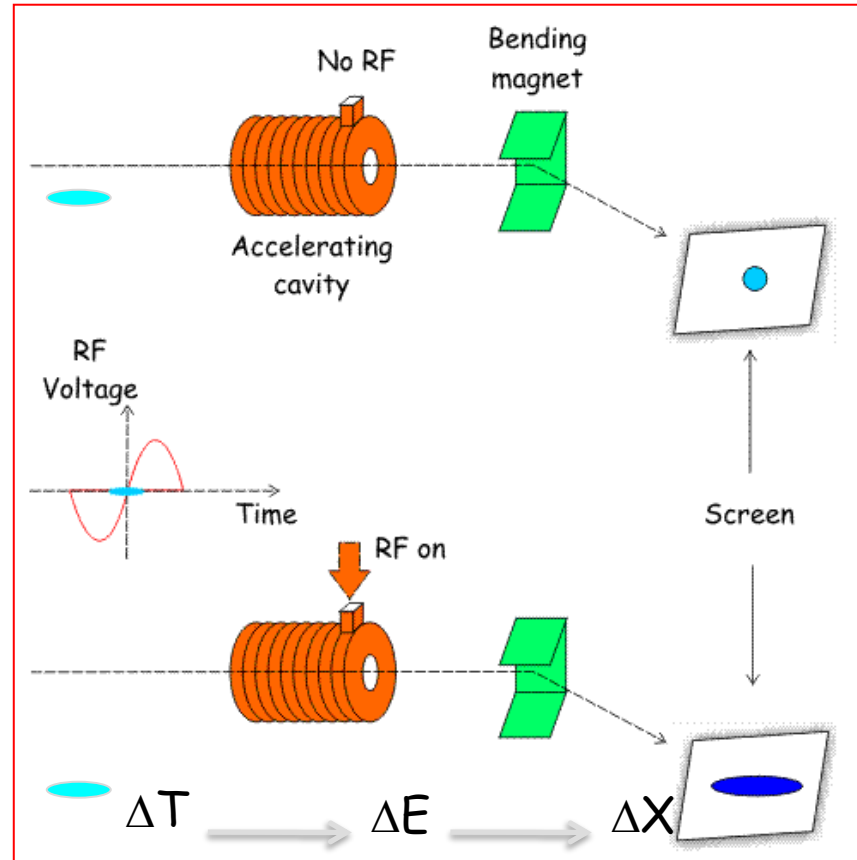
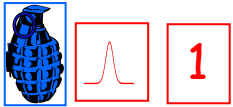

RF Accelerating cavities

CEBAF injector, Newport News

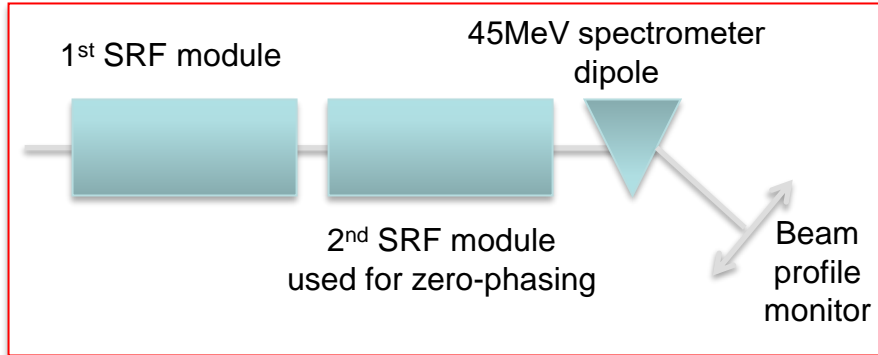

D. X. Wang *et al*, Physical Review E57 (1998) 2283

84fs, 45MeV beam but low charge beam

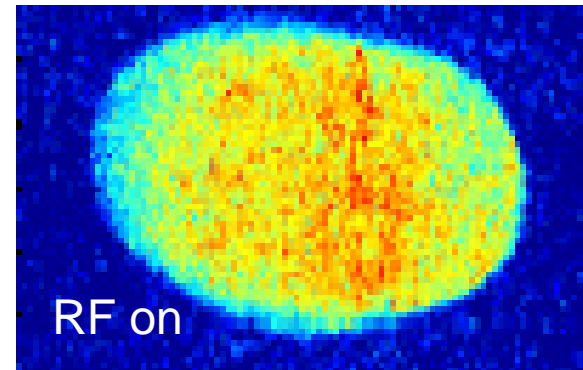
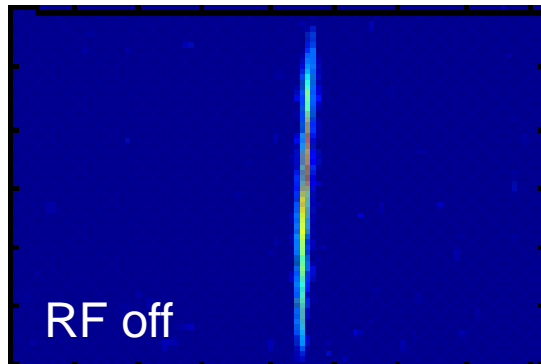

Limitations

RF non linearities
Beam loading and wakefield for high charge beam

RF Accelerating cavities

SLAC LCLS: at 4.7 GeV

- 550m of linac at RF zero crossing!
- 6m dispersion in spectrometer line

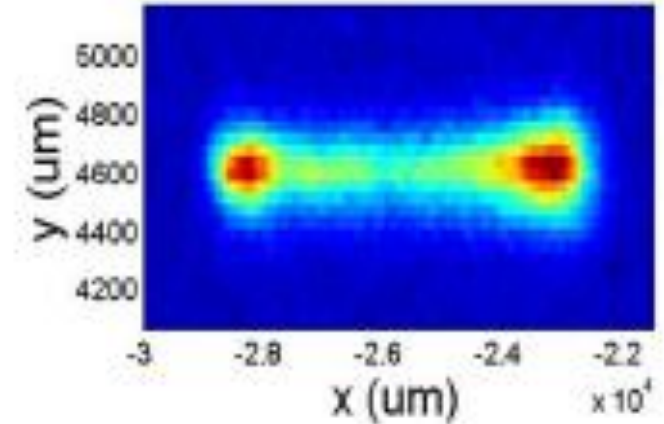

Z. Huang et al. PAC 2011, FEL2013

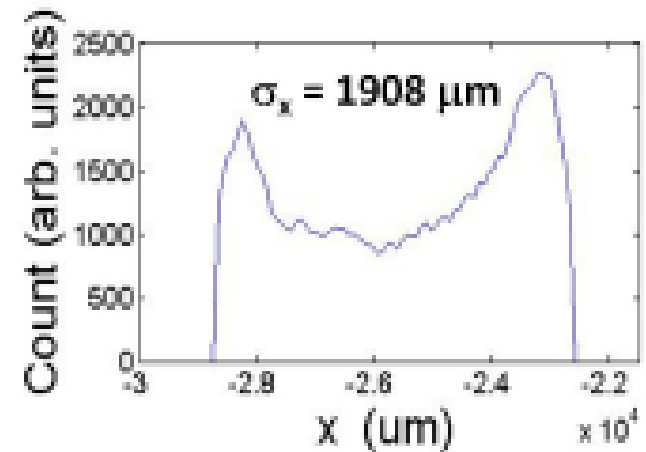
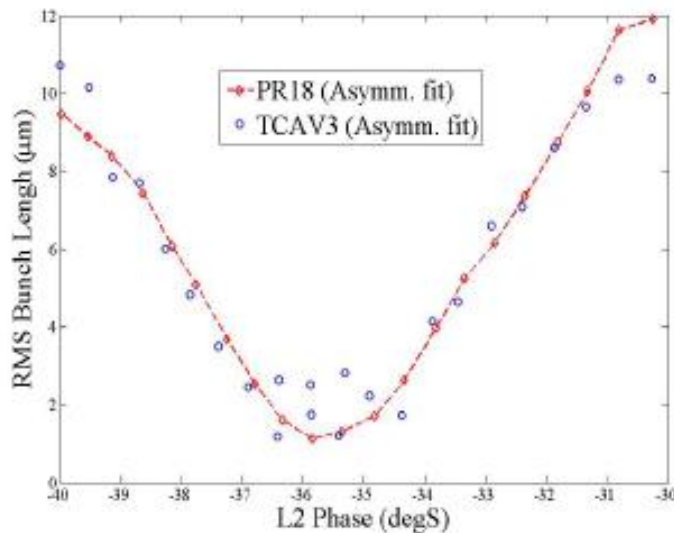

TCAV3

~ 1 fs rms bunch length at 4.7 GeV

Laser-based diagnostics

Sampling techniques

Using a short laser pulse to scan through the beam profile

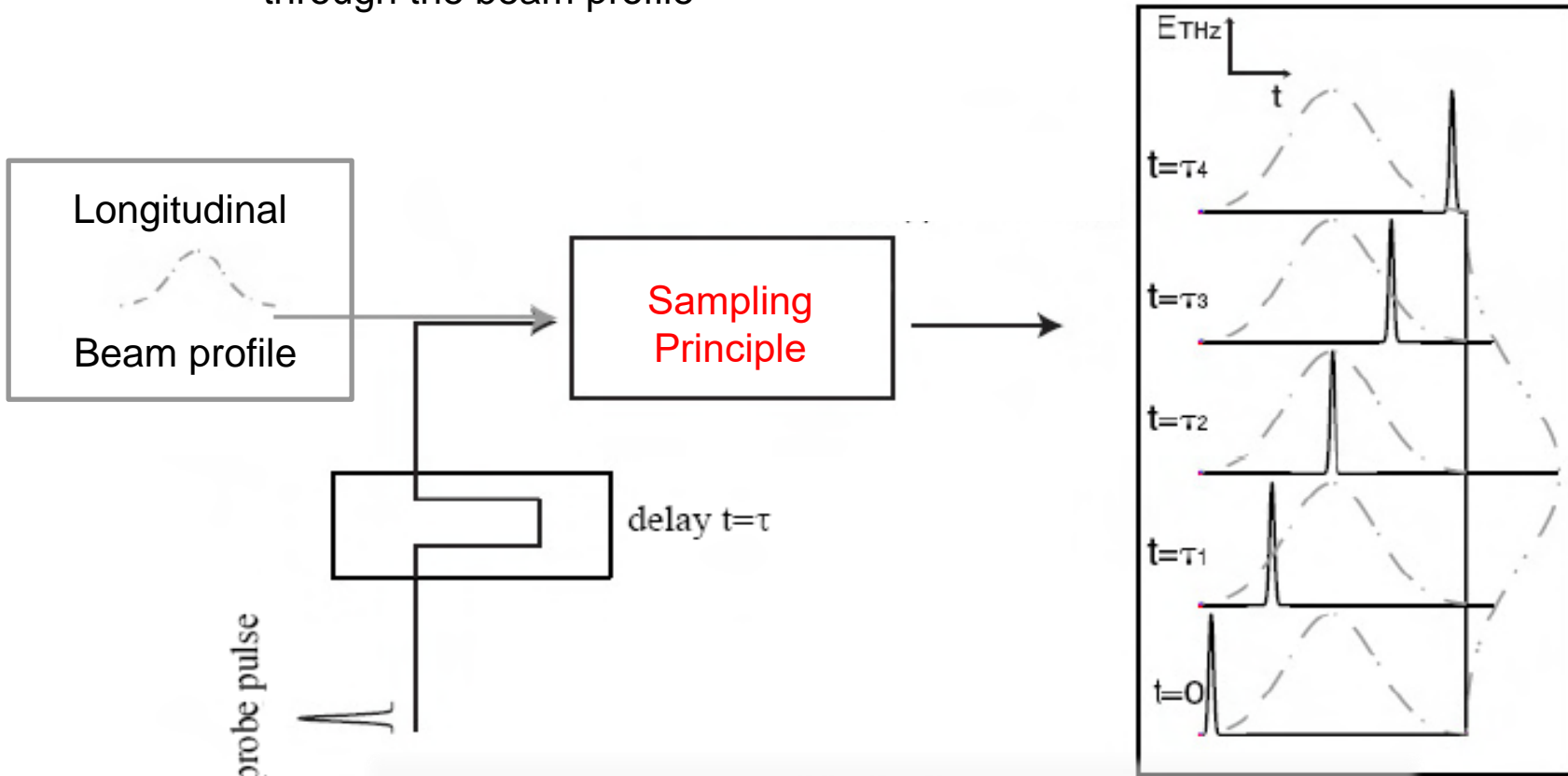

Limitation
Laser-beam synchronization jitter should be smaller than the bunch length to measure

Laser Wire Scanner

High power laser

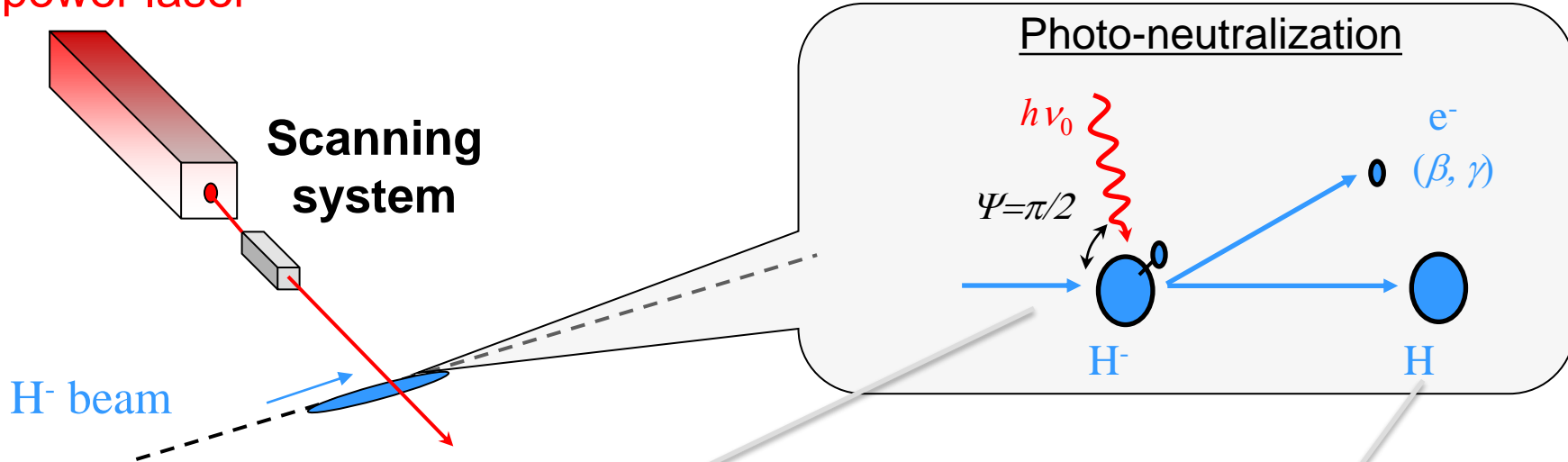

- First ionization potential for H⁻ ions is 0.75eV
- Photo-neutralization cross section : $\sigma \sim 4 \cdot 10^{-17} \text{ cm}^2$

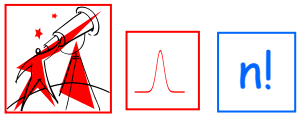
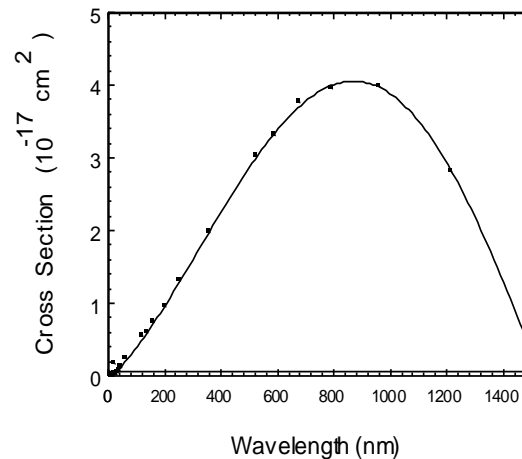

- Detection system based on**
- The measurement of released electrons using a magnet and a collector (faraday cup, MCP,..)
 - Measured the conversion of H⁻ into H with a current monitor

Laser Wire Scanner

Longitudinal Measurements @ SNS

2.5 MeV H^- , 402.5 MHz bunching freq, Ti-Sapphire laser phase-locked @ $1/5^{\text{th}}$ bunching frequency
S. Assadi et al, Proceedings of EPAC 2006, Edinburgh, pp 3161

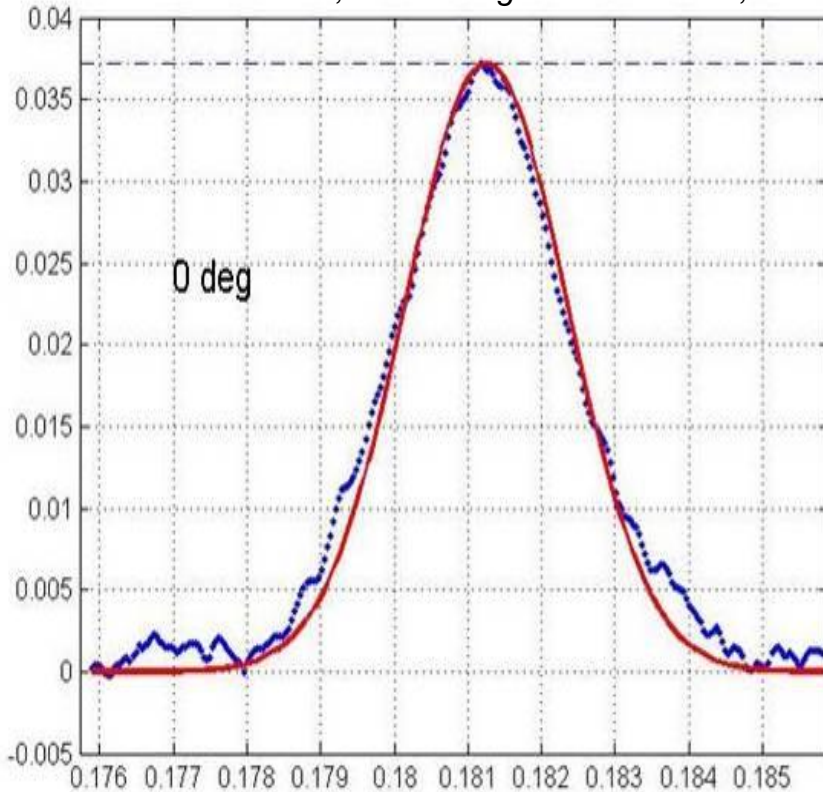

Collected electron signal plotted vs. phase

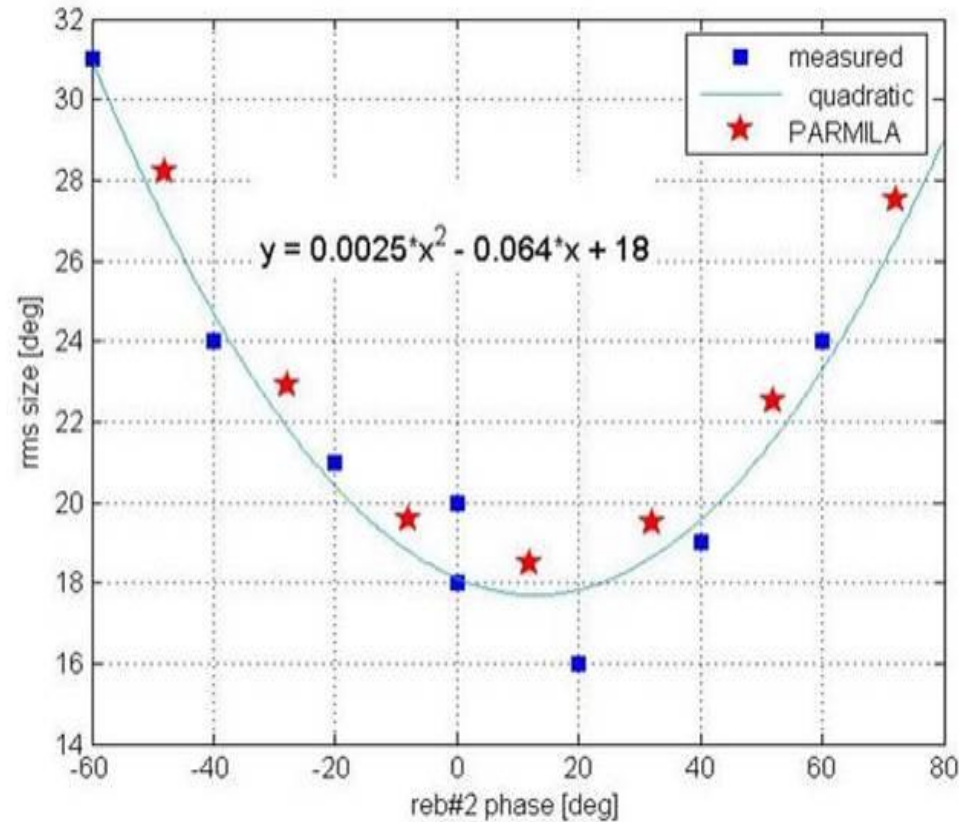

Measured and predicted bunch length vs. cavity phase setting

Laser Wire Scanner

High power laser

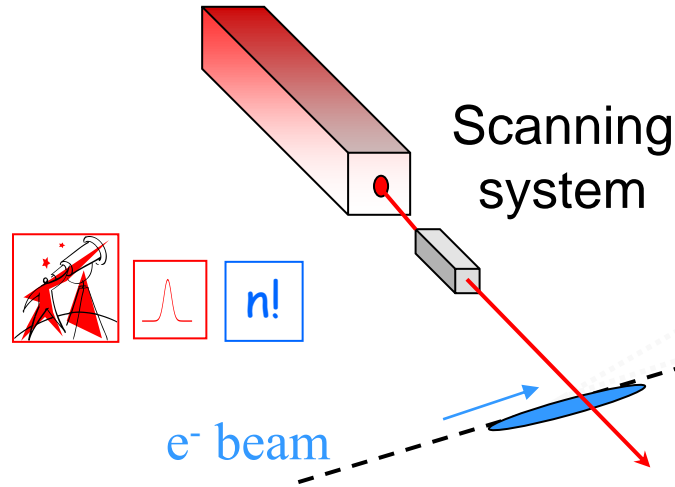

Thomson/Compton scattering

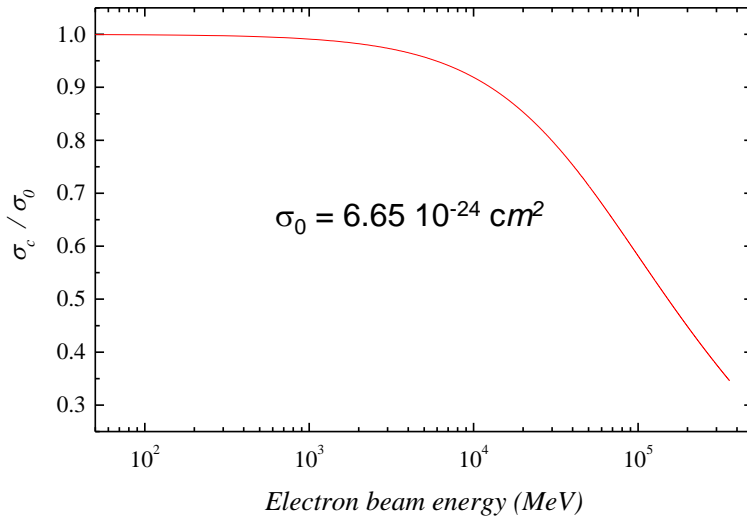
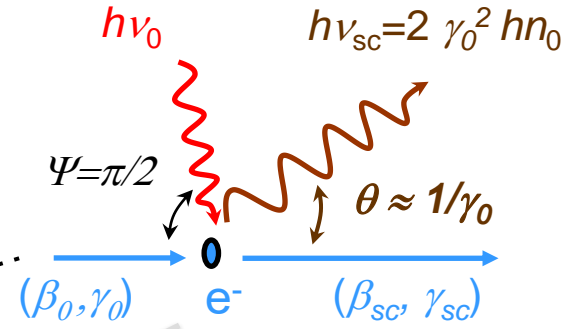

- Detection system based on**
- The measurement of the scattered photons
 - The measurement of degraded electrons

Laser Wire Scanner

ALS @ LBNL

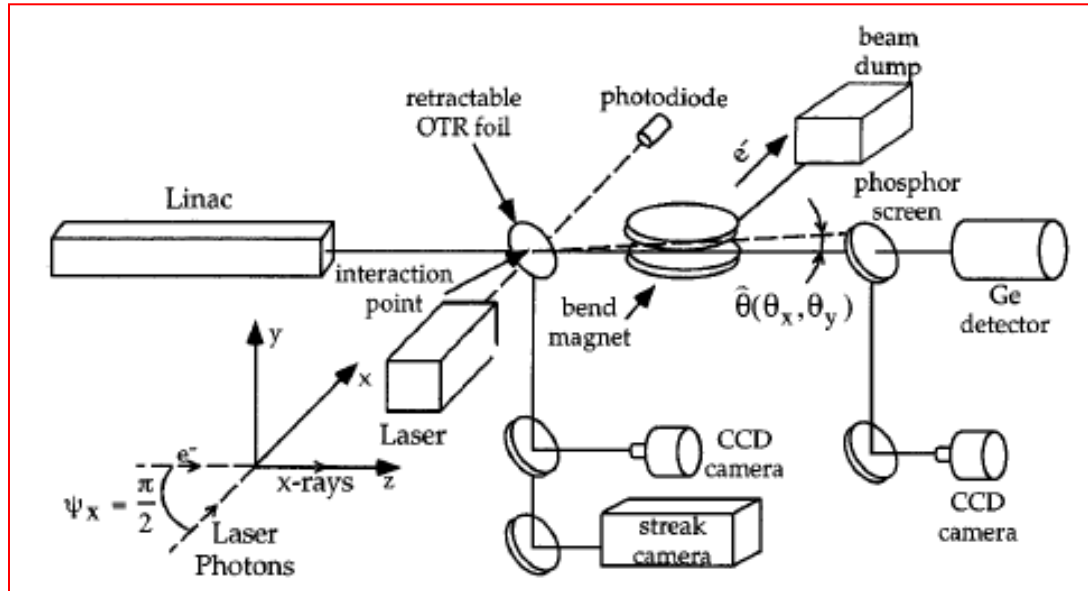

W.P. Leemans et al, PRL 77 (1996) 4182

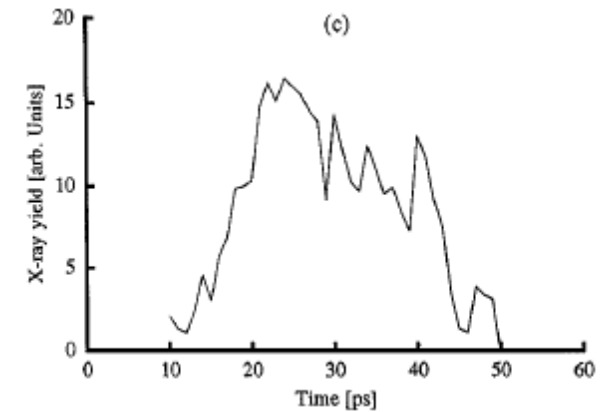
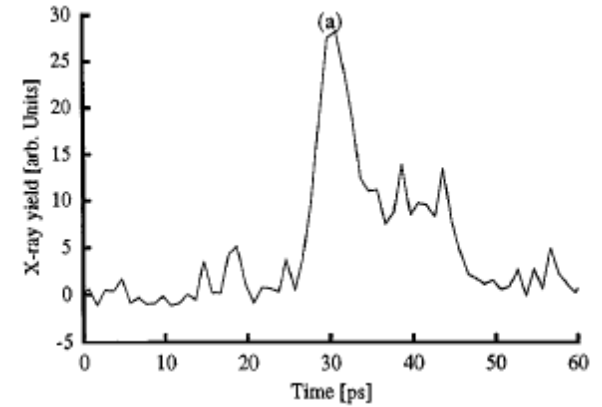

Using a 10TW Ti:Al₂O₃ laser system. Detecting 5.10⁴ 10-40 keV X-rays using either an X-ray CCD and Ge detector.

Electro-optical techniques

'This method is based on the polarization change of a laser beam which passes through a crystal itself polarized by the electrons electric field'

E-field induced birefringence in EO-crystal : Pockel/Kerr effect

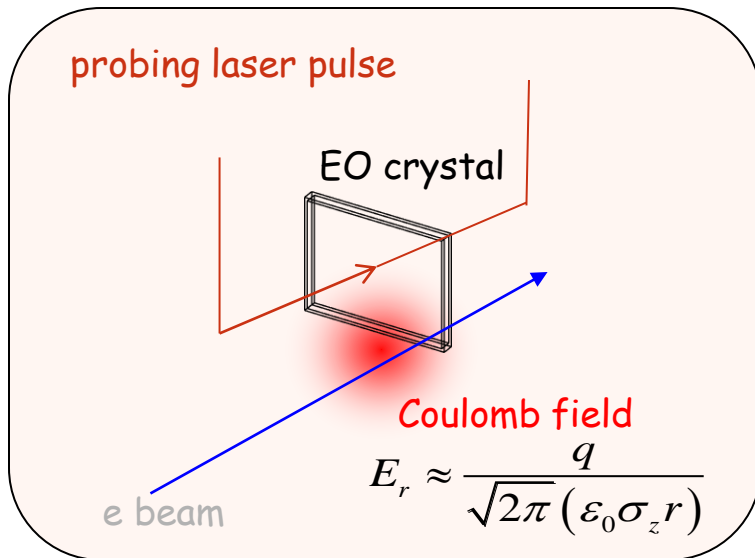

- Polarization diagram
- electric field of the horizontal polarization
- electric field of the vertical polarization

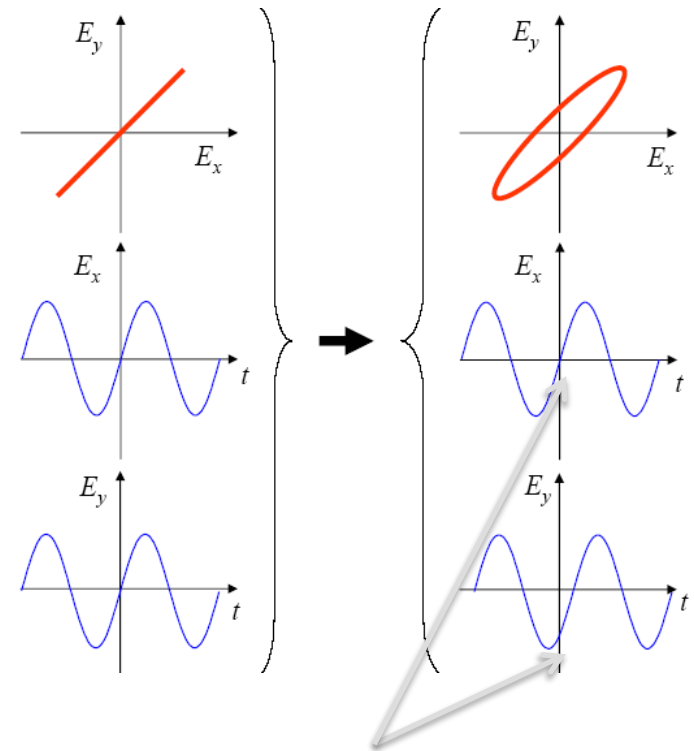

$$G = \frac{2pd}{l_0} (n_x - n_y) = \frac{2pd}{l_0} n_0^3 r_{41} E_r$$

Relative phase shift between polarizations increases with the beam electric field

Bunch length and bunch field

Field radiated or probed is related to **Coulomb field near the electron bunch**

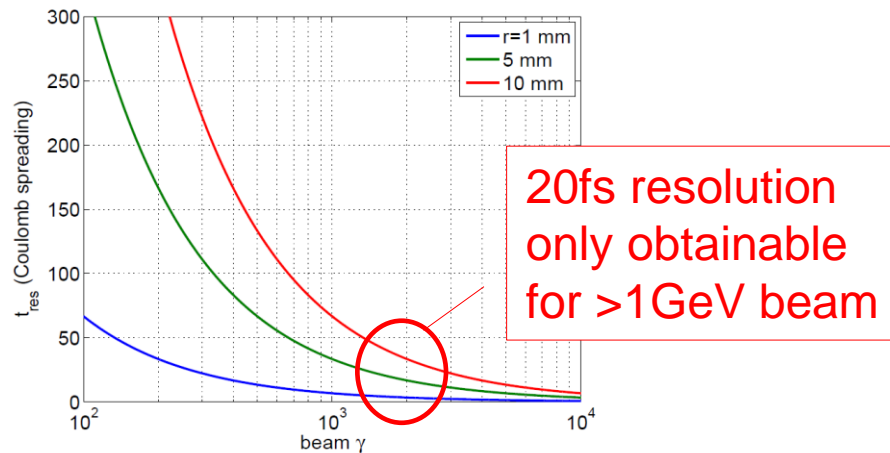
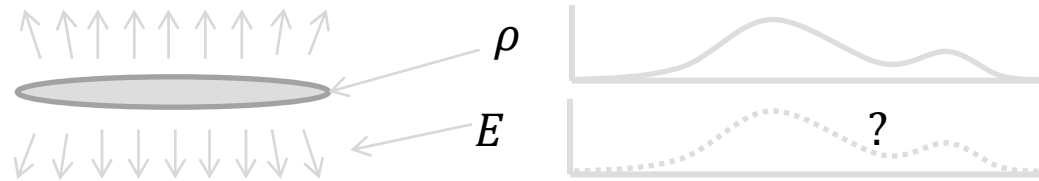

20fs resolution only obtainable for >1 GeV beam

High γ is an advantage!

Time response & spectrum of field is dependent on spatial position, r :

$$\delta t \sim 2r / c\gamma$$

⇒ ultrafast time resolution requires close proximity to bunch

Spectral decoding

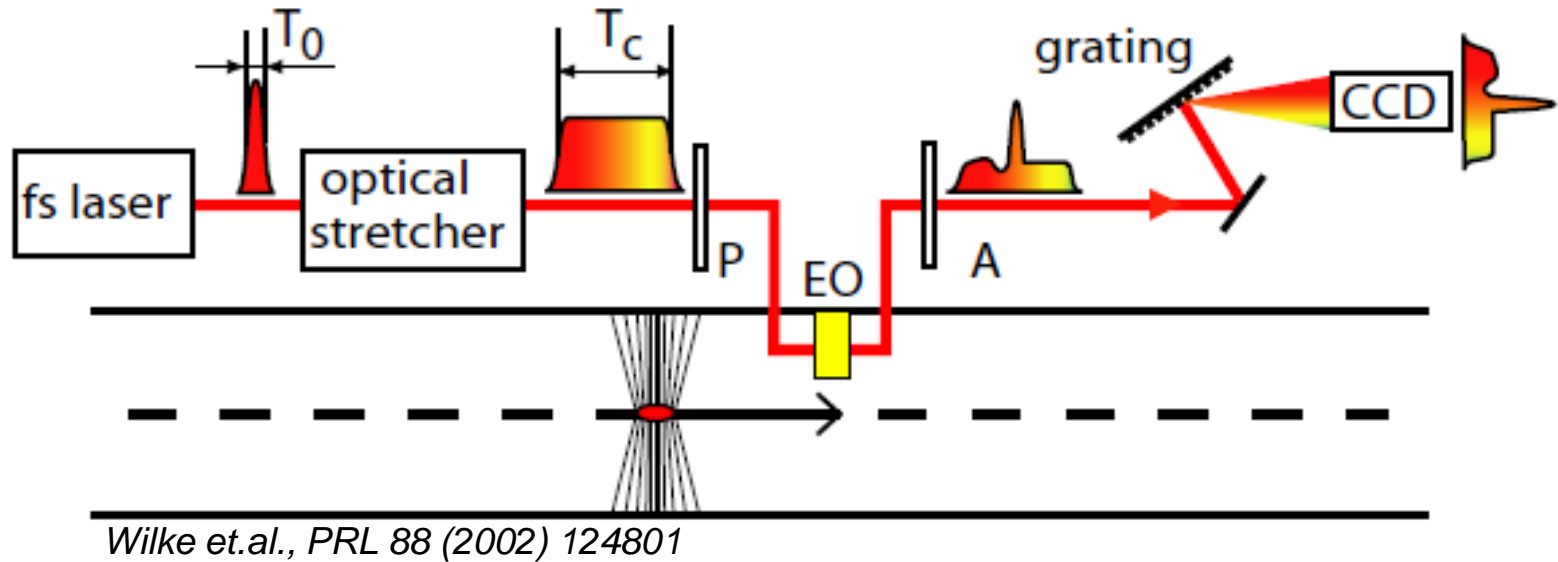

Single bunch measurements by detection the wavelength spectrum in spectrometer (position vs wavelength) of a chirped laser pulse (time vs wavelength)

- Artifacts due to frequency mixing
- Minimum resolution in the order

$$T_{\text{lim}} \approx 2.6 \sqrt{T_0 T_c}$$

Single shot measurements at the XFEL bunch compressor 1

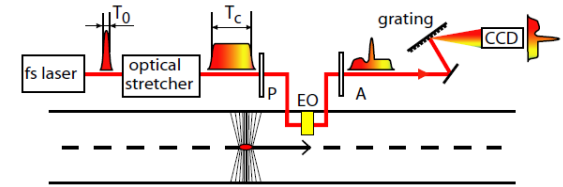
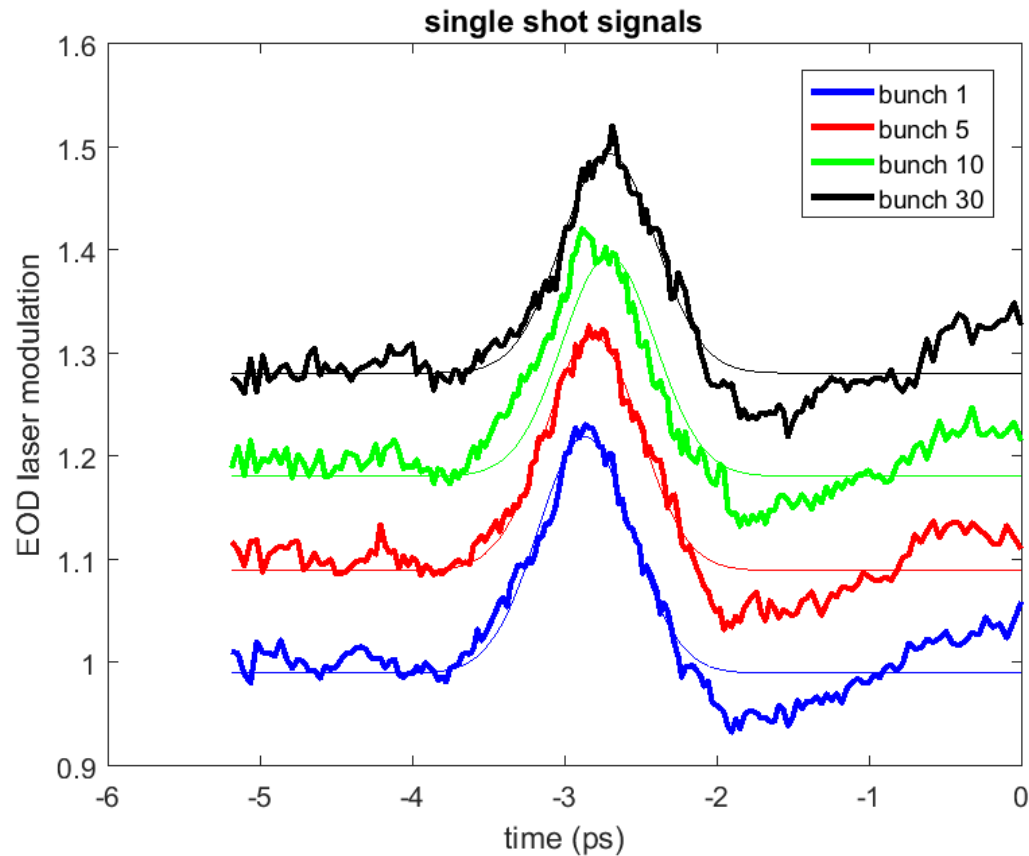

Temporal decoding

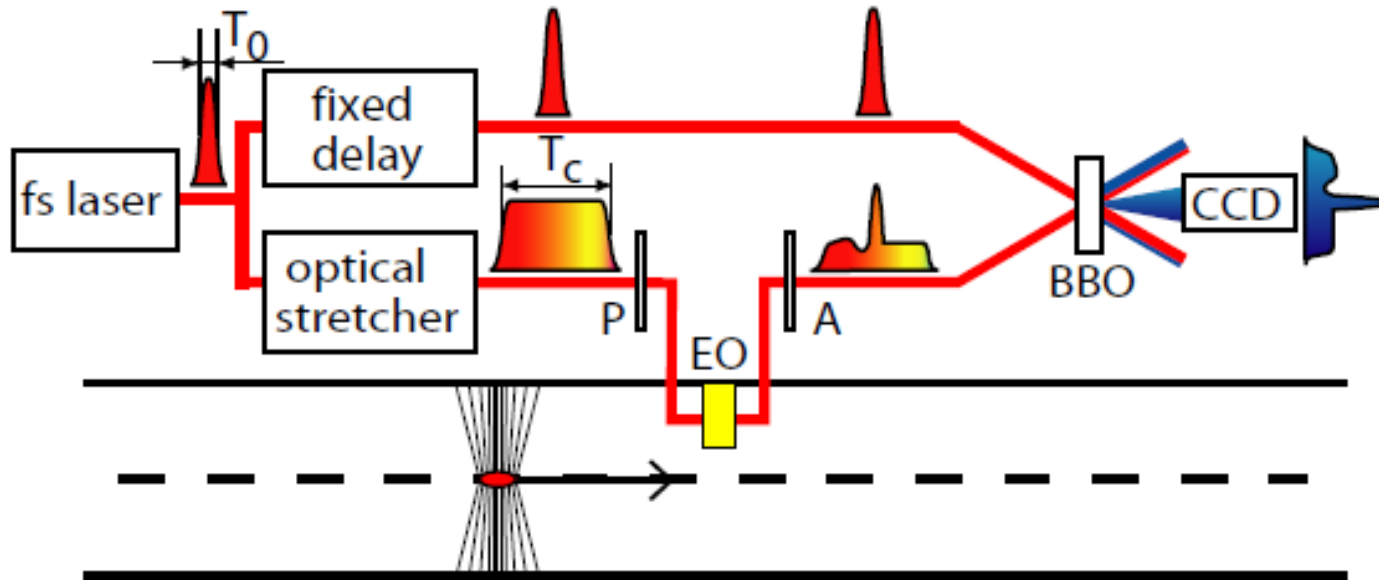

Berden et.al, PRL 93 (2004) 114802

- Beta barium borate (BBO) crystals are nonlinear optical crystal for second harmonic generation (SHG)
- Low efficiency of Second Harmonic Generation process, approx. 1mJ laser pulse energy necessary
- Resolution : duration of the gate beam, thickness of the SHG crystal – 50 fs or slightly better

Temporal decoding

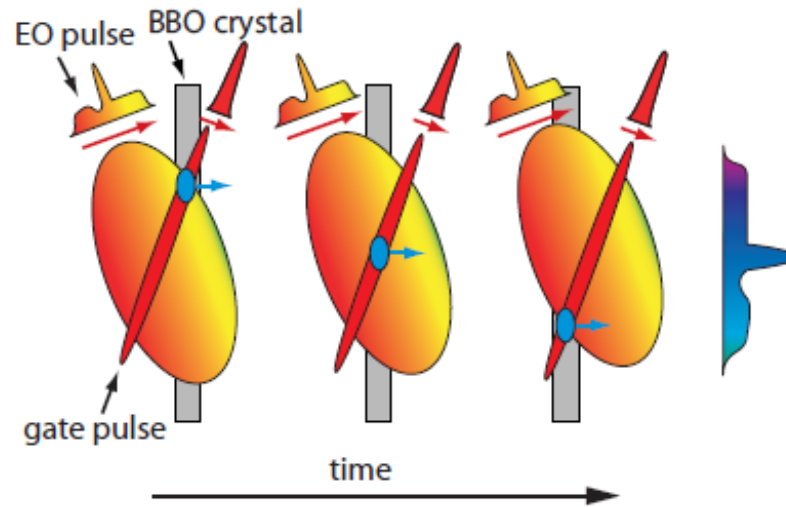

- The short gate pulse overlaps with different temporal slices of the EO pulse at different spatial positions of the BBO crystal.
- Thus the temporal modulation of the EO pulse is transferred to spatial distribution of the SHG laser beam.

Temporal decoding

Measurement performed at FLASH/DESY

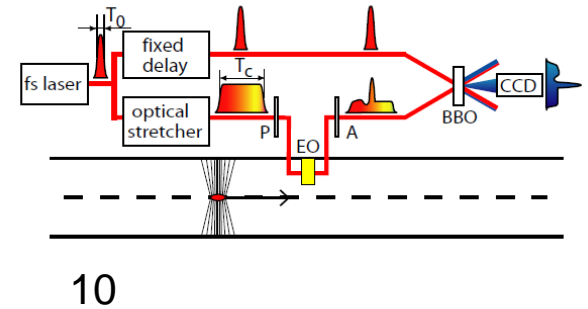
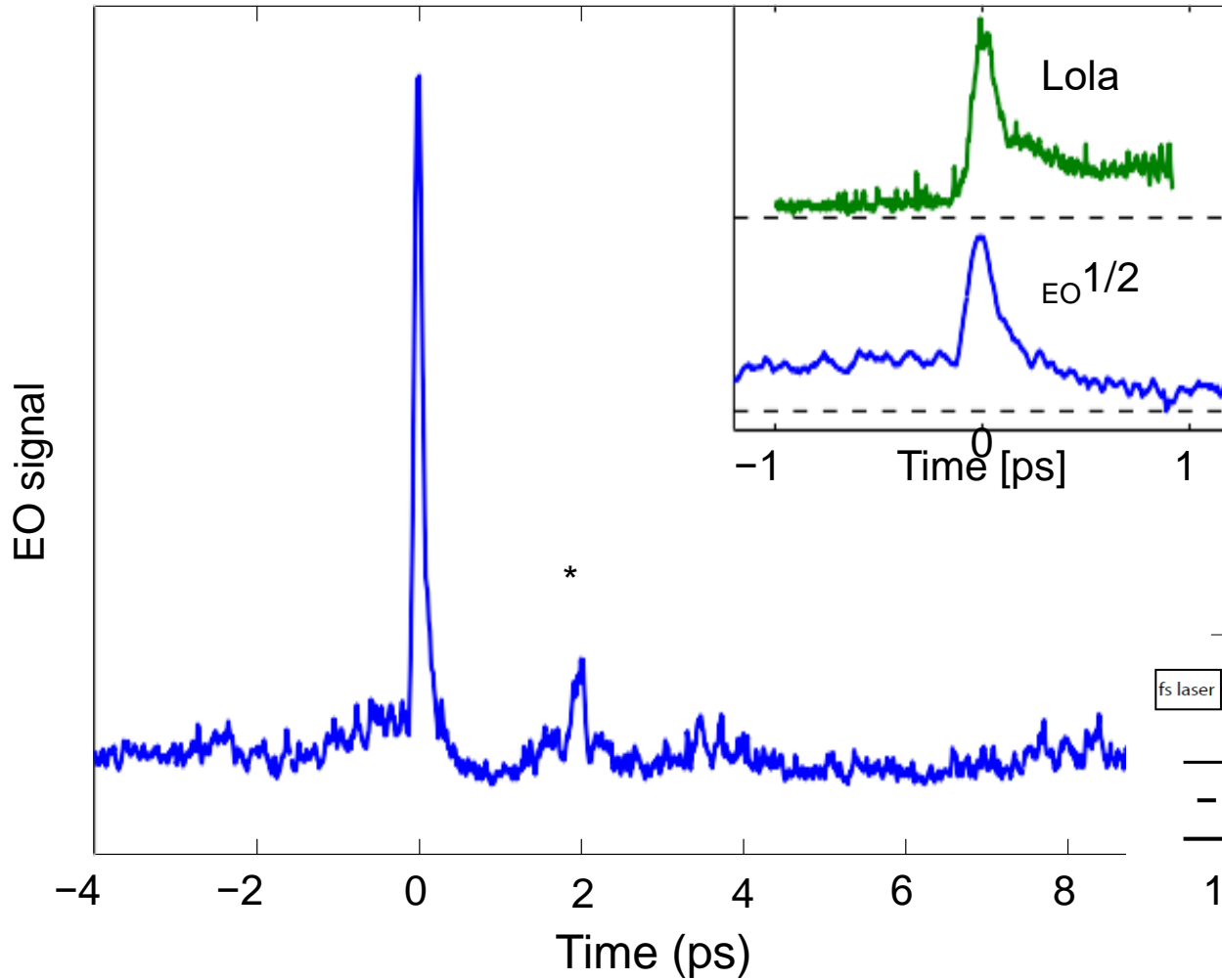



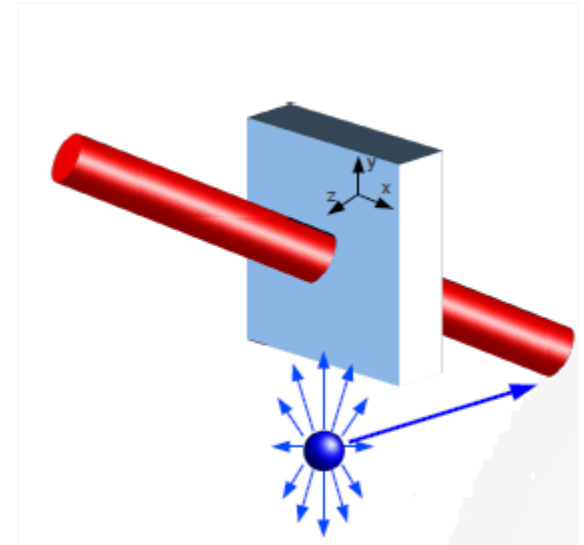
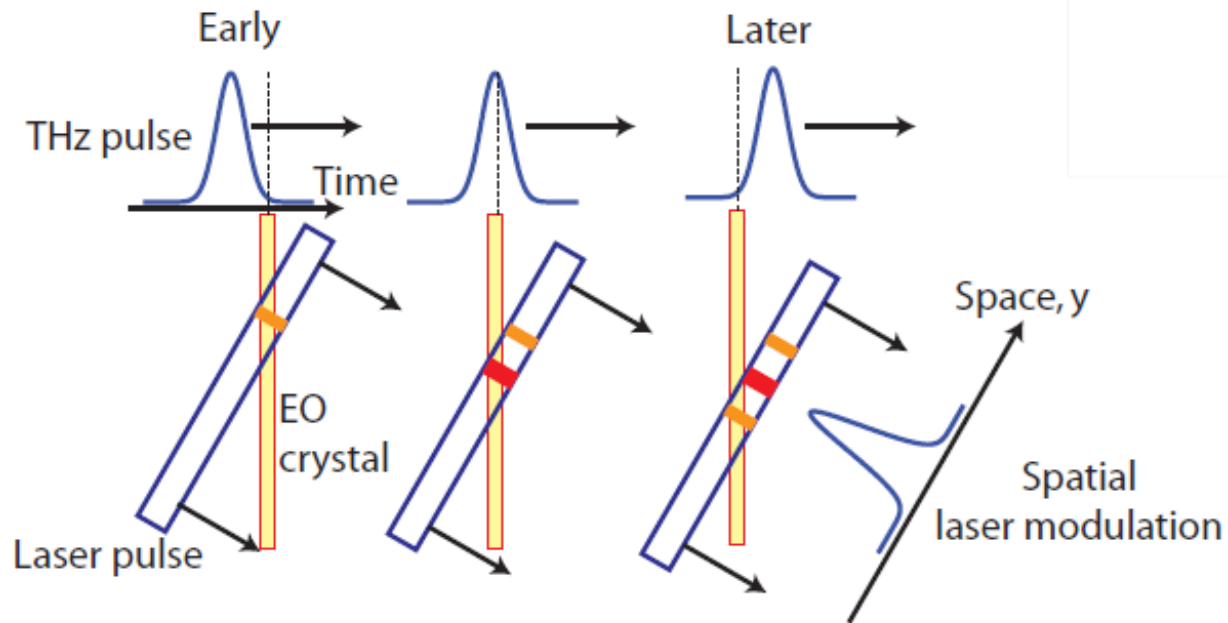



Spatial decoding



Cavaliere *et. al*, PRL 94 (2005) 114801
 Jamison *et. al*, Opt. Lett. 28 (2003) 1710
 Van Tilborg *et. al*, Opt. Lett. 32 (2007) 313

Summary

	 	 	 	Limitations
• Optical radiation				
• Cherenkov / OTR radiation	X			
• ODR / OSR Radiation	X			
• Streak camera		X		200fs
• Coherent radiation : Bunch spectrum				
• Interferometry		X	X	
• Polychromator		X	X	
• RF techniques				
• 'Feschenko' monitor	X	X	X	Hadron, 20ps
• RF Deflector	X	X	X	1fs
• Zero phasing techniques	X	X	X	10fs
• Laser based Method				
• Sampling			X	Jitter (10fs)
• Non linear mixing		X		
• Thomson/Compton scattering	X	X		Electron
• Photo-neutralization	X	X		H ⁻
• Electro-Optic Sampling	X	X		
• E-O Spectral decoding	X	X	X	~ 200fs
• E-O Spatial decoding	X	X	X	~ 50fs
• E-O Temporal decoding	X	X	X	~ 50fs

Conclusions

- Short bunch length measurements are challenging
- Resolution of few fs achieved operationally
- Field in constant move driven by the advances in FELs and novel accelerating technologies
- Another exciting field of R&D !

Thank you for your attention