

Radiation and magnetic field qualification of LVPS

a unified 12 VDC power source for the CMS detector

W. Lustermann, K. Stachon

On behalf of the CMS collaboration

TWEPP 2024, Glasgow, United Kingdom

- Introduction
- LV system concept
- Radiation testing
- Magnetic field testing
- Summary

Introduction

CMS requires new low voltage power supplies for several subdetectors

- High Granularity Calorimeter, MIP timing detector and Electromagnetic Calorimeter
- Use Point of Load (POL) converters, employing CERN's **bPOL12V** controller ASIC
- **Total Power: > 500 kW**, Voltage at POL: (9 to 12)V
- 3 types of 12V modules: $V_{out} = (7-13)V$ + 2 variants with $V_{out} = 60V$
 - 12ch x 60W
 - 6ch x 120W
 - 3ch x 240W

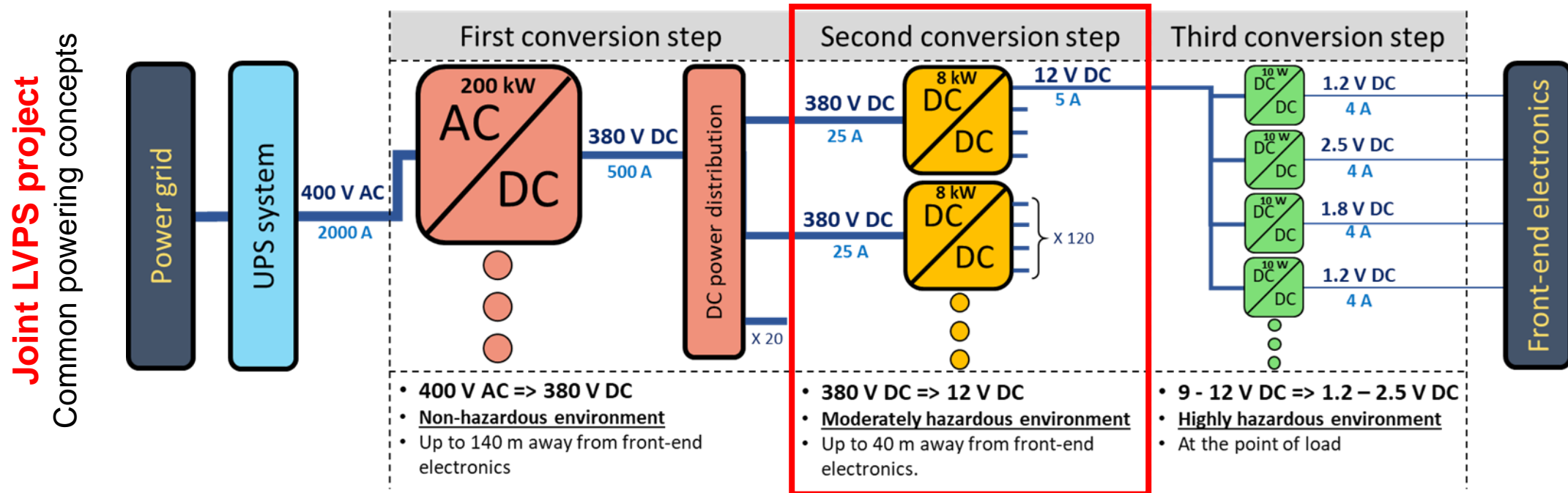

Power module – schematic view (second conversion step)

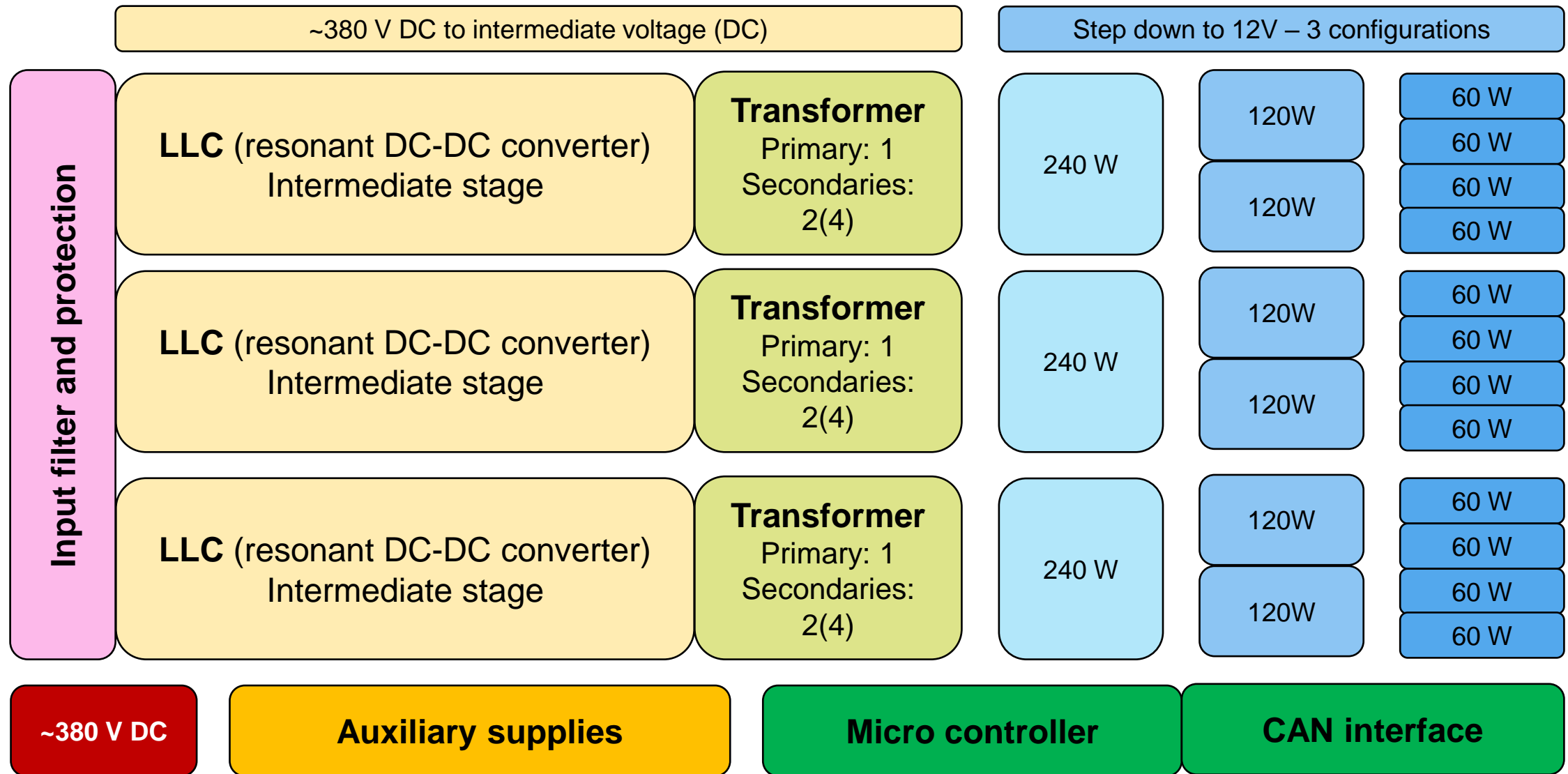

Development

Goal: Development of radiation and magnetic field tolerant low voltage power supplies using components of the shelf

- Destination: CMS experimental cavern
- Max. B-field: 120mT
- TID: 32Gy
- High energy hadron (>20MeV) fluence: $2 \times 10^{11} / \text{cm}^2$

Responsibility

Contractor: Kontron HARTMANN-WIENER

Main features

- High power density: 7.2kW / 5U
- Over voltage protection (analog and μc -processed)
- Over current protection
- CAN-BUS control interface

Strategy – Radiation and B-field compatibility

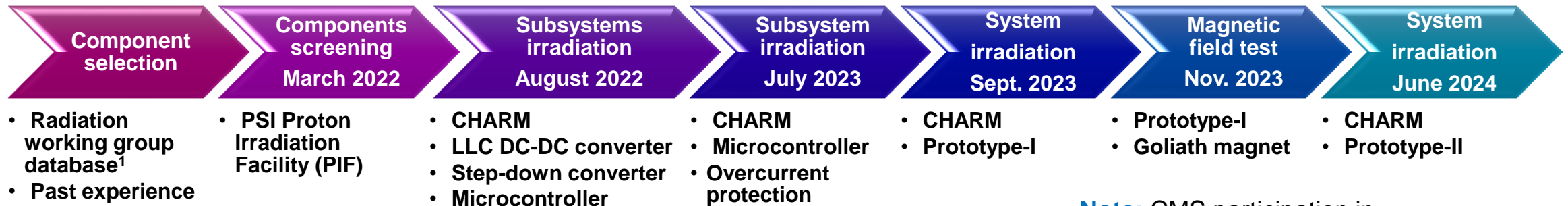

Note: CMS participation in

- Components selection.
- Radiation and B-field tests.

¹<https://radwg.web.cern.ch/>

CHARM CERN Highly-Accelerated Mixed Field Facility
PSI PIF Paul Scherrer Institute Proton Irradiation Facility

Status, Plans

- Prototype-III in preparation
- **Next (final) irradiation test: ~spring 2025**
- **Next (final) magnetic field test: ~Nov 2024**

Subsystem radiation testing – CHARM July 2023

Re-check problems found in CHARM Aug 2022

- Overcurrent protection (OCP): spurious triggers

Components tested

- AMP 1: ON Semi MC34072
- AMP 2: TI LM358D
- Comparator 1: ON Semi MC34072
- Comparator 2: TI LM293D

Method

- Input: Current ramping in 60s cycles:
 - Output sampling: V_{AMP} and V_{OCP} 600kS/s (300kHz BW)
 - NI-PXI system:
 - 4 x DMM 4081, synchronized (shared clock and trigger)
 - 1 x PXI 6251 – trigger generation

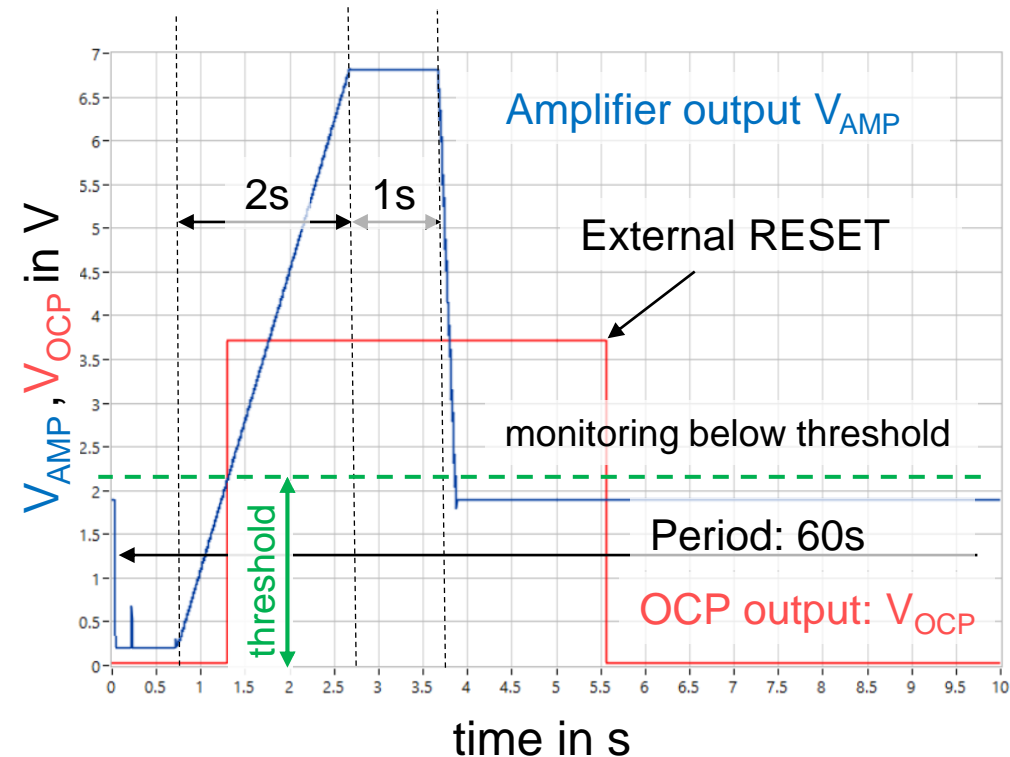
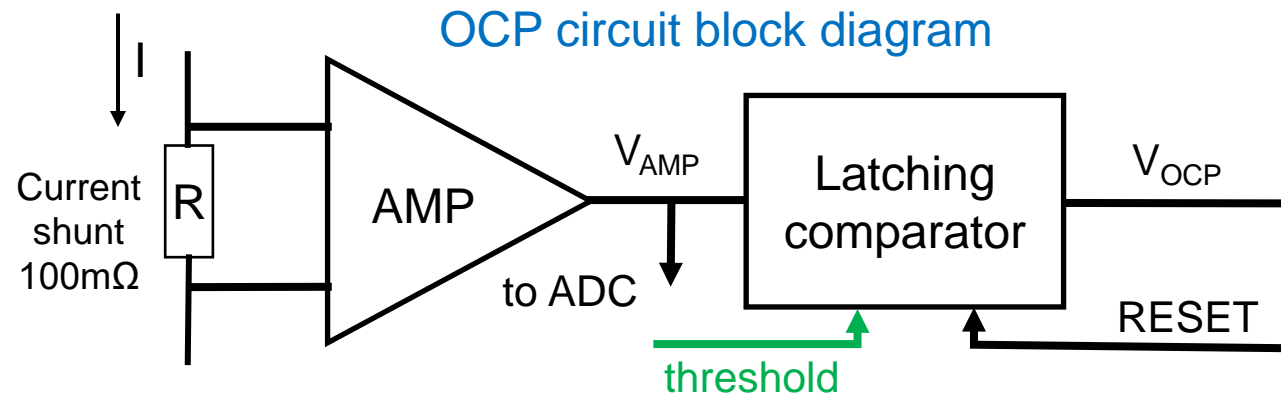

Subsystem radiation testing – CHARM July 2023

Results

- Drift of V_{AMP}
- Drift of V_{OCP} comparator
- ➔ LM358D and LM293D recommended
- ➔ Lower drift

Spikes observable

- Spurious OCP triggers!
- ~identical shape
- $T \sim 100\mu s$

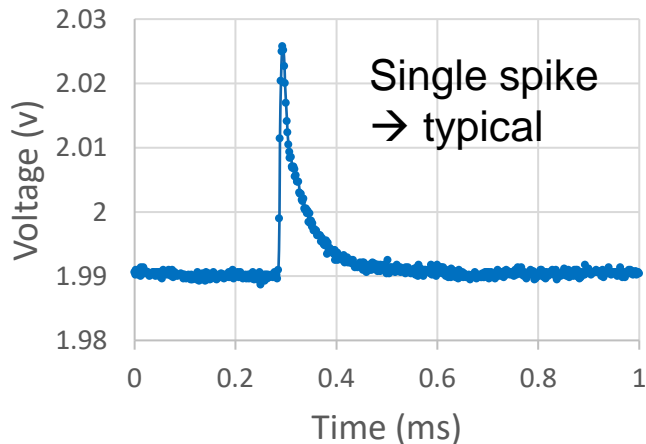

OCP circuit outputs

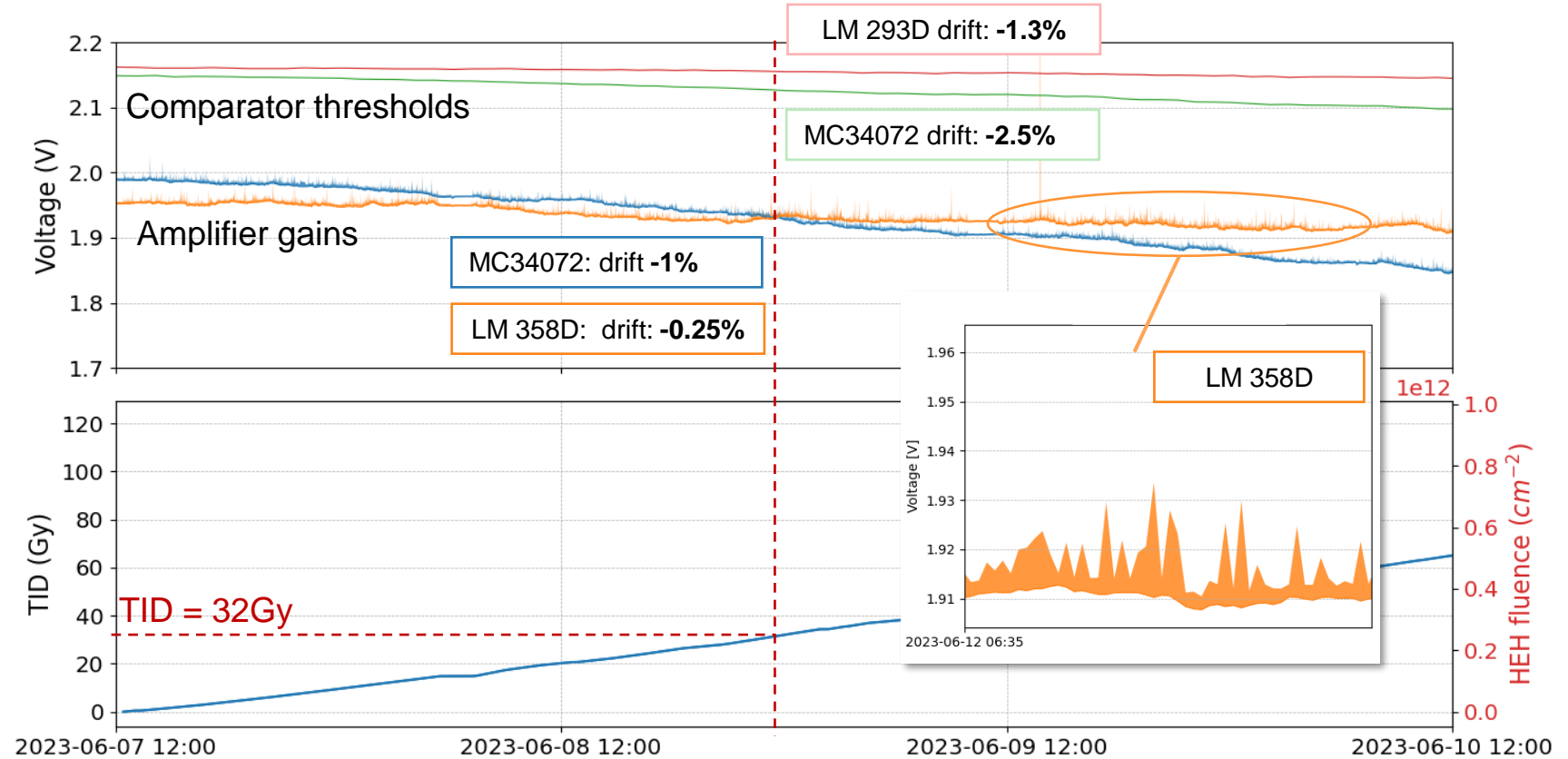

➔ low pass filtering added: cutoff frequency 800Hz

Prototype-I radiation test – CHARM Sept. 2023

Test procedure

A.1) Continuous DAQ of all input / output currents and voltages.

A.2) Logging of all exposed power supply parameters: 50% load

B) Periodic tests, every 3 hours:

- Input power cycling
- Idle current measurement
- Interlock test
- Enable/disable test - channel-by-channel:
 - Two ramp-up speeds: 1ms, 20ms
 - 11 load values, 0-100%, steps 10%
- OCP test – scan OCP values:
 - 11 load currents, 0-100%, steps 10%
- Efficiency measurement – channel by channel
 - 10 load values, 10-100%, steps 10%
 - $V_{in} = 380V$

Measurement setup

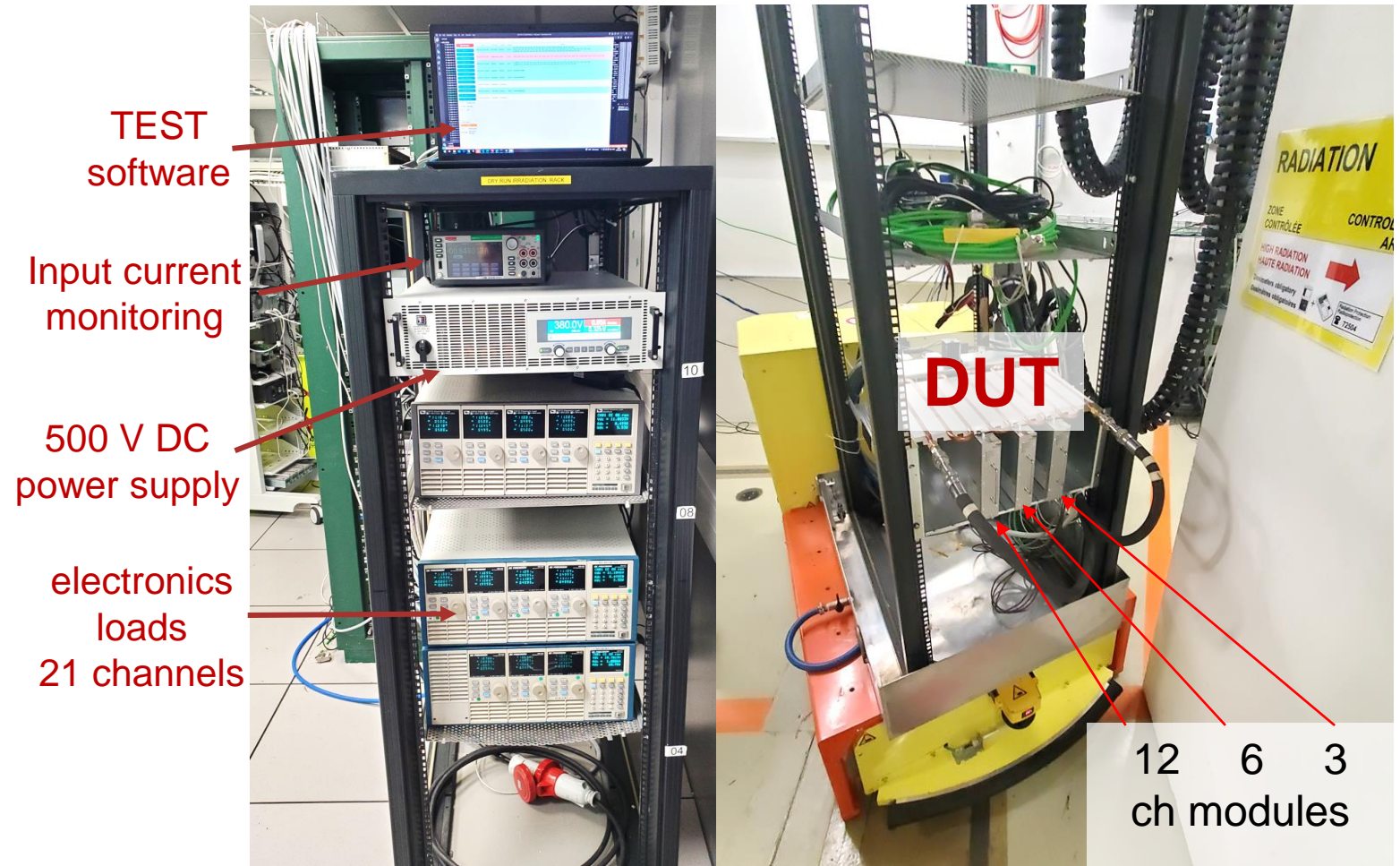

Prototype-I radiation testing – CHARM Sept. 2023

Anomalies observed

1) CAN communication lost:

- Recovered with power-cycle:
 - Firmware missed CAN configuration memory recovery
- Corrected

2) One single channel failed

- **Power input fuse broken:**
- Not radiation induced
- Suspicion: sequence of ~100 power cycles in a row “stressed” the fuse
- Corrected: delay for turn-on introduced

3) Power cycling: startup failed

- 3ch – 30Gy
- 6ch – 45Gy
- 12ch – 47Gy

Root cause: auxiliary supplies didn't start because of drift in LDO (LM317) output, providing kick-off power to auxiliary supplies

→ Corrected: different LDO

4) One digital isolator failed

- At > 100Gy
- Single occasion at high TID → Ignored

Prototype-II radiation testing – CHARM June 2024

New Modules

- With previous problems fixed

Problem 1

- Drift of output current I_{out} measurement
 - Shunt resistor and amplifier gain had been changed
- Correction: Increase shunt resistance, lower AMP gain, use LM358D, LM293D

Problem 2

- 4 digital isolators failed
- Wasn't exact part from radiation database

Correction: change type

Procedures like in previous test

Added:

- Output voltage test: 12 points (6.0 – 12.5)V
- Efficiency measurement – aggregate by module
 - 10 load values, 10-100%, steps 10%
 - $V_{out} = 10V$ and $12V$

Measurement setup as before

Improvements:

- Separate power lines per module
- Separate CAN buses
- Improved software

Output current measurement

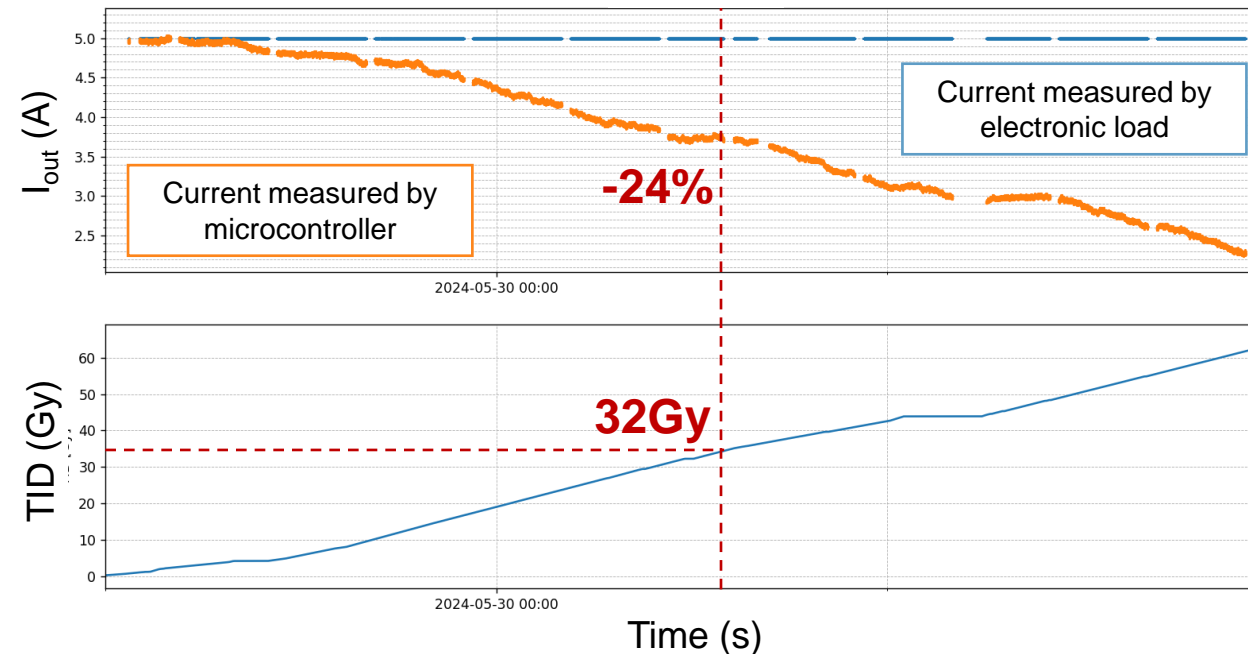

Prototype-II radiation testing – CHARM June 2024

Excellent voltage regulation on all 21 channels

- Slight drift ($\sim 10\text{mV}$) with temperature at start-up
- Load 50% of max load
- Small jumps, beam induced

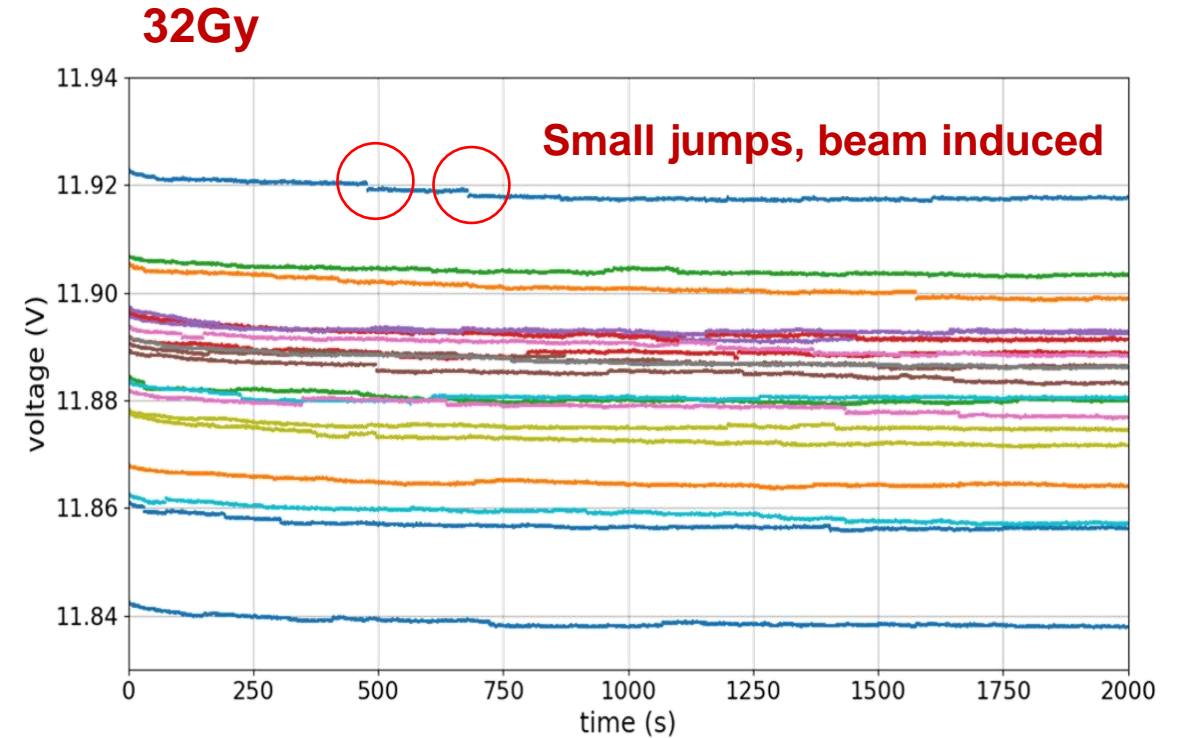
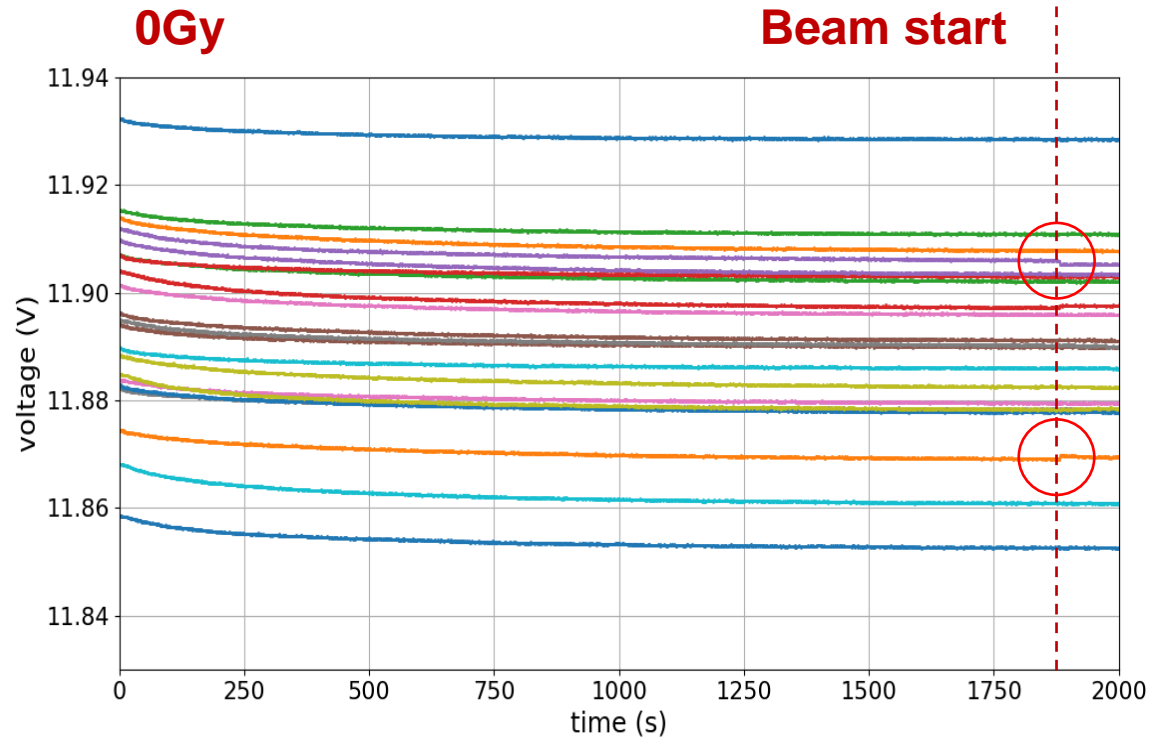

Prototype-II CHARM June 2024

Efficiencies values computed from acquired data

- Overall as expected
- Minor change with radiation – actually to slightly higher efficiency

Requirement

- >88% at > 40% of full load = 96 W

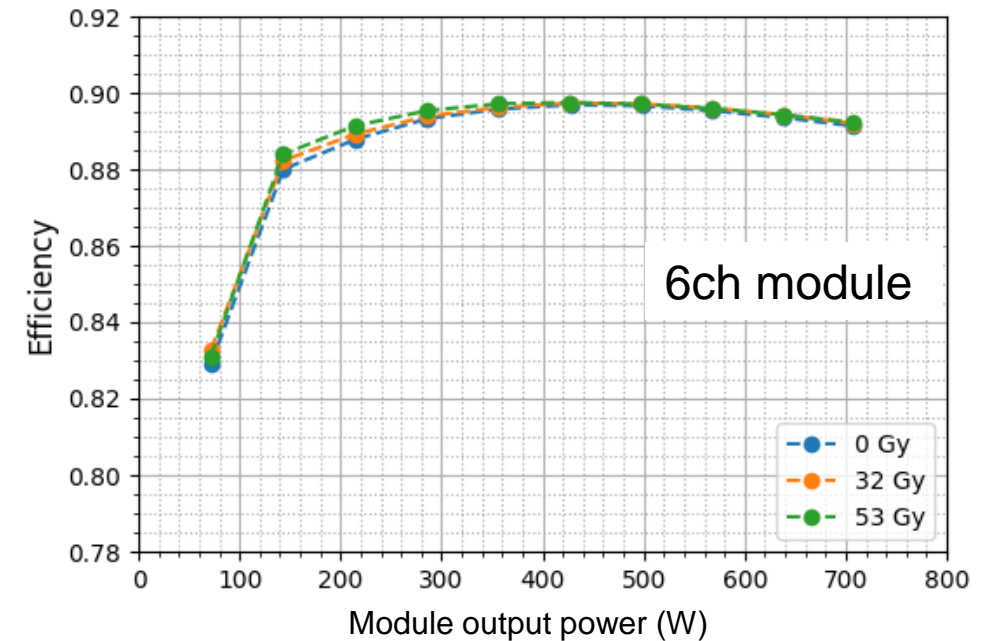
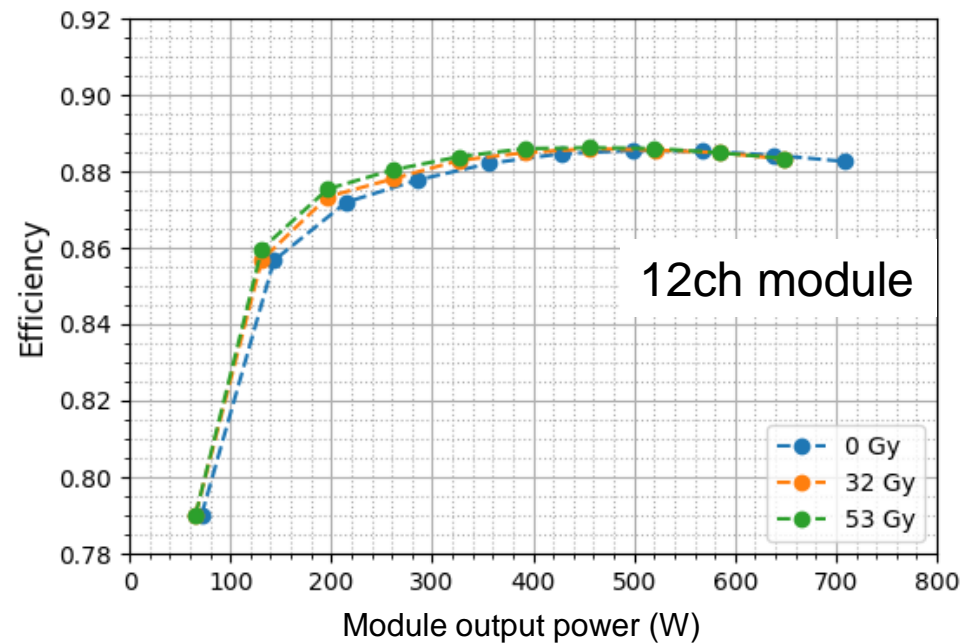
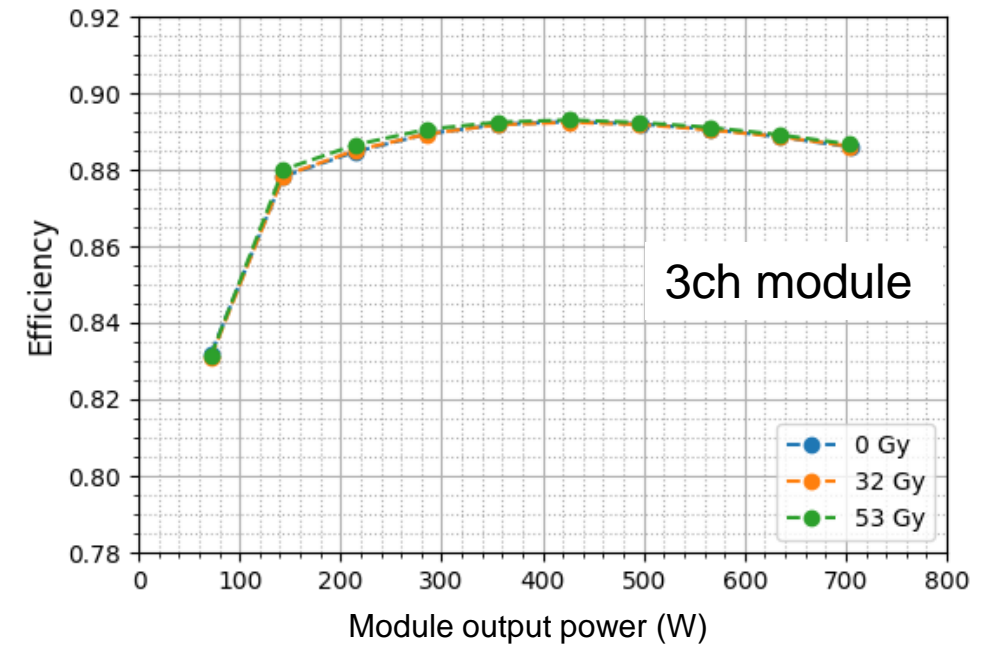

Improvements

Enable Disable output voltage
→ ramp-up
→ ramp-down

Prototype-I
CHARM Sept. 2023

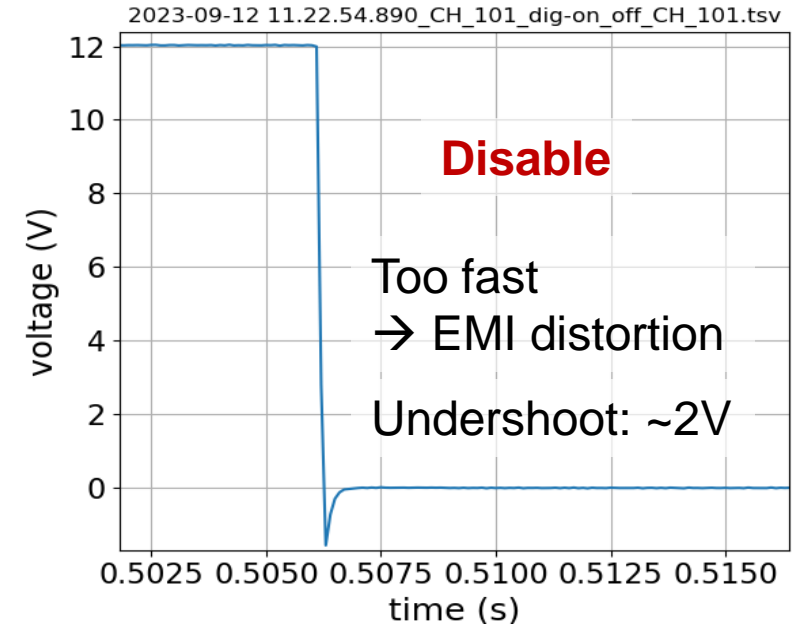
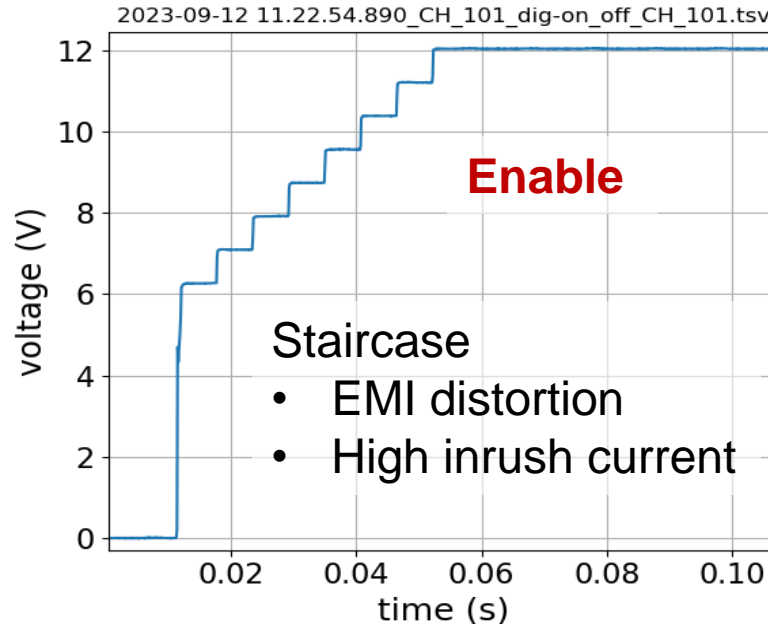

Prototype-II
CHARM June 2024

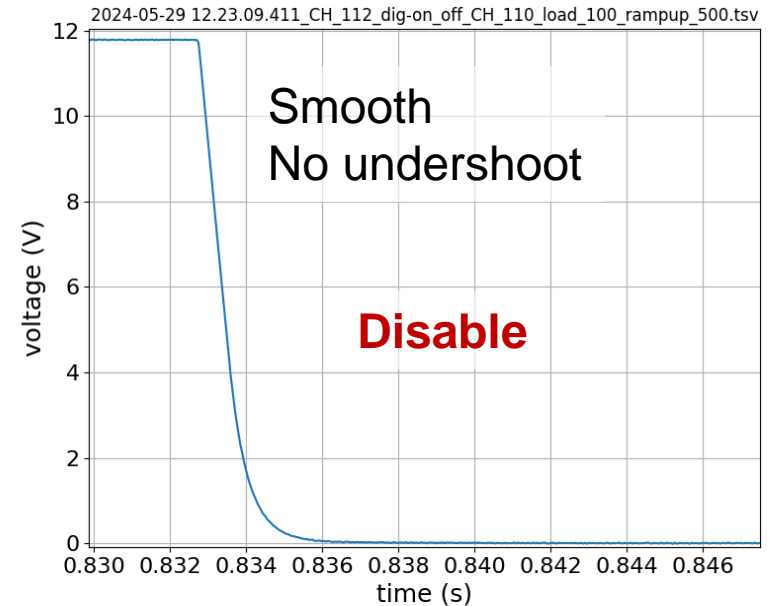
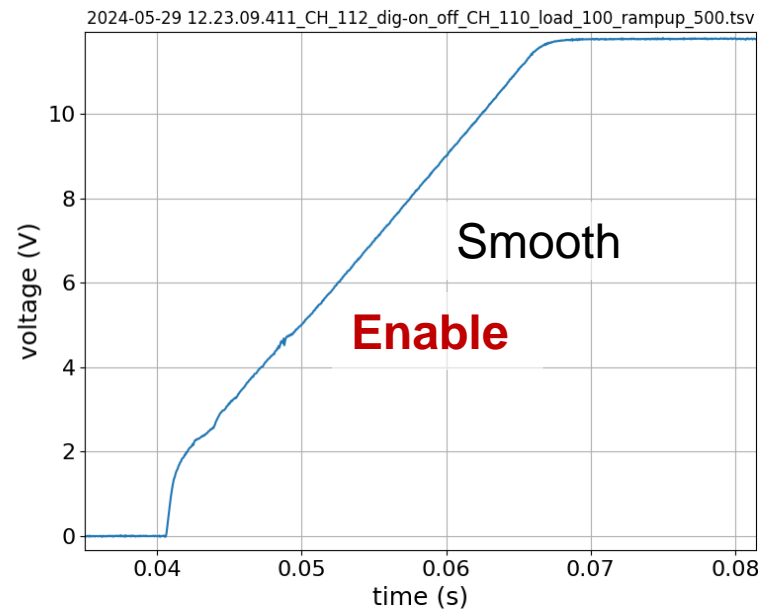

Prototype-I magnetic field testing – Goliath 2-3 Nov. 2023

B-field compatibility

- Estimated max. B-field: ~120 mT
- Testing: (0 – 132) mT (+10%)

Magnet

- Goliath magnet (CERN H4 beam line)
- $B_{\max} = 1.6 \text{ T}$, accuracy at 100 mT <1%

Measurements

- Input voltage and all output voltages
- Input current
- Efficiency

Equipment

- 400V DC supply (EA 9500)
- Electronics load (ITECH IT8700)
- 2 x Keithley DAQ6510 + 7702 MUX cards
- 1 x Keithley DAQ7510

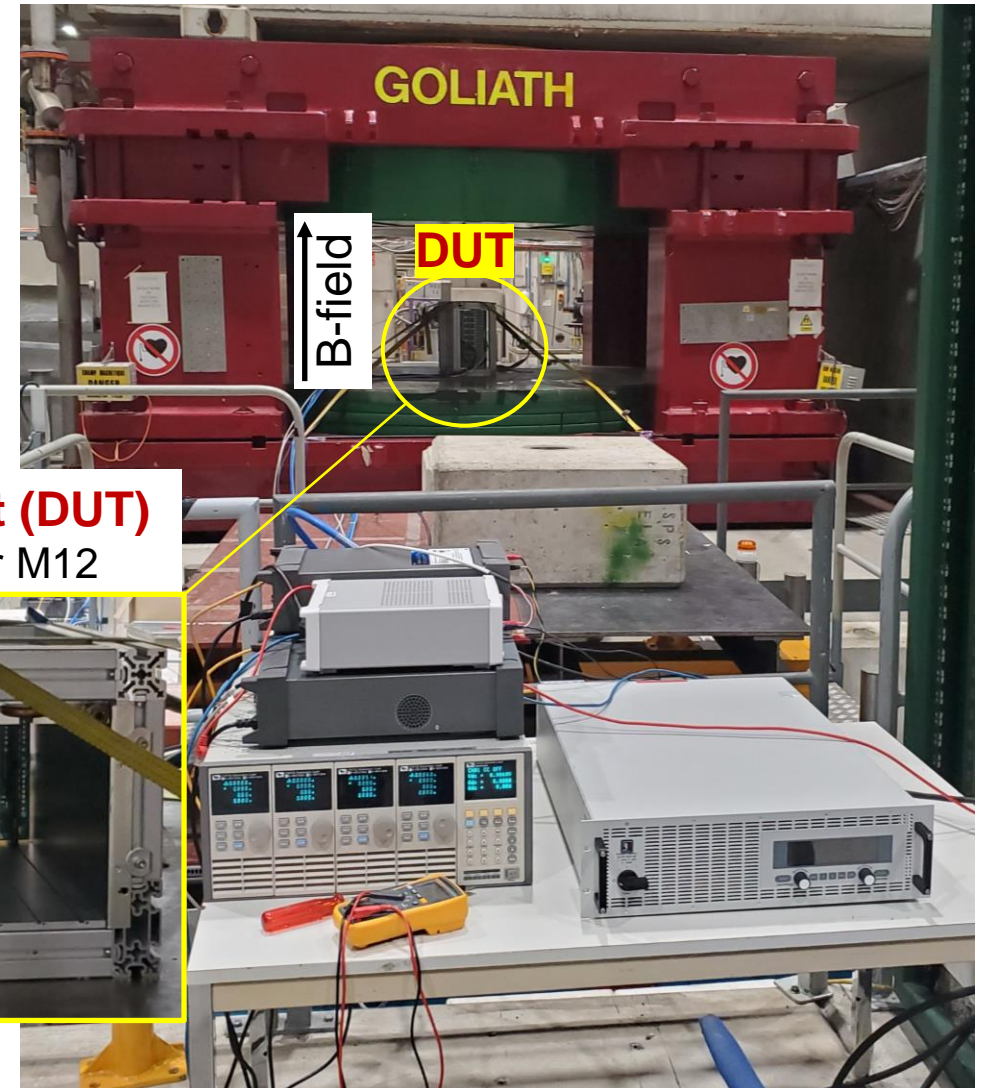

Device Under Test (DUT)

- One module M6 or M12



Efficiency vs B-field

Efficiency

- Output power / Input power
- Calculated from measured input and output voltages
- $V_{in} = 380V$
- Correct for idle current: 0.078A

Module

- M6 120W
- 2-channels aggregate = 1 LLC
- Output power = 240W

Results

- x: **ok**
- y: **not ok** ($B > \sim 90mT$)
- z: **not ok** ($B > \sim 90mT$)

Requirement

- $>88\%$ at $> 40\%$ of full load = 96 W

B-field

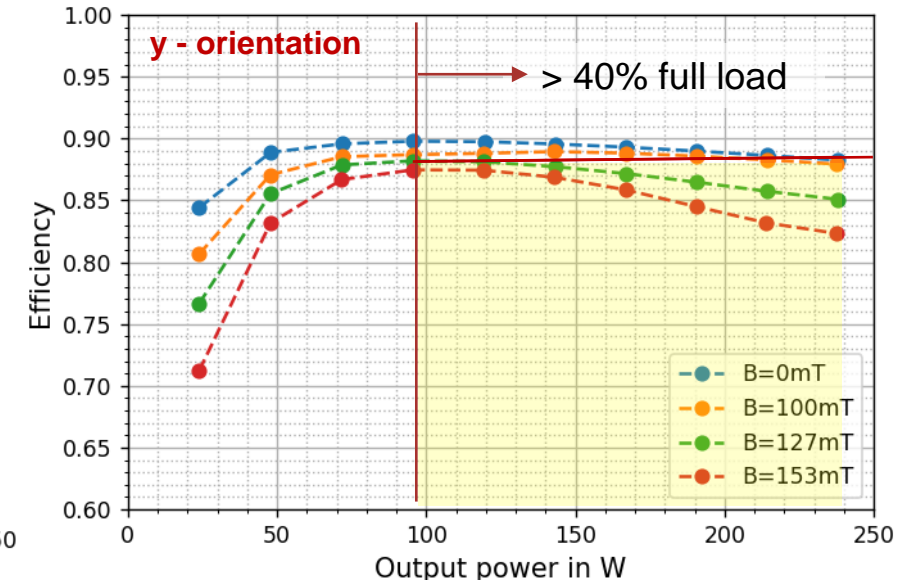
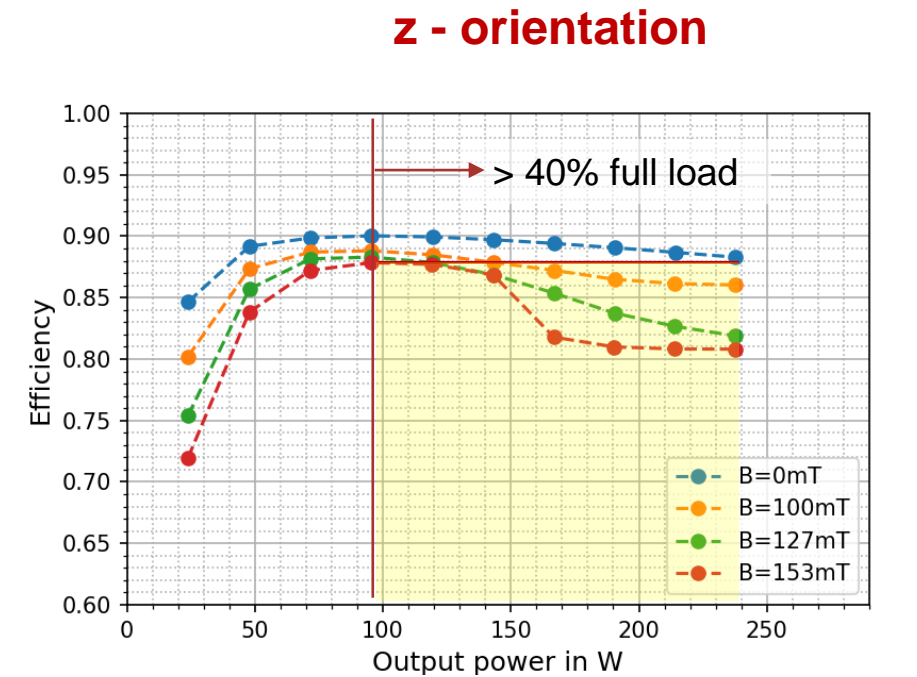
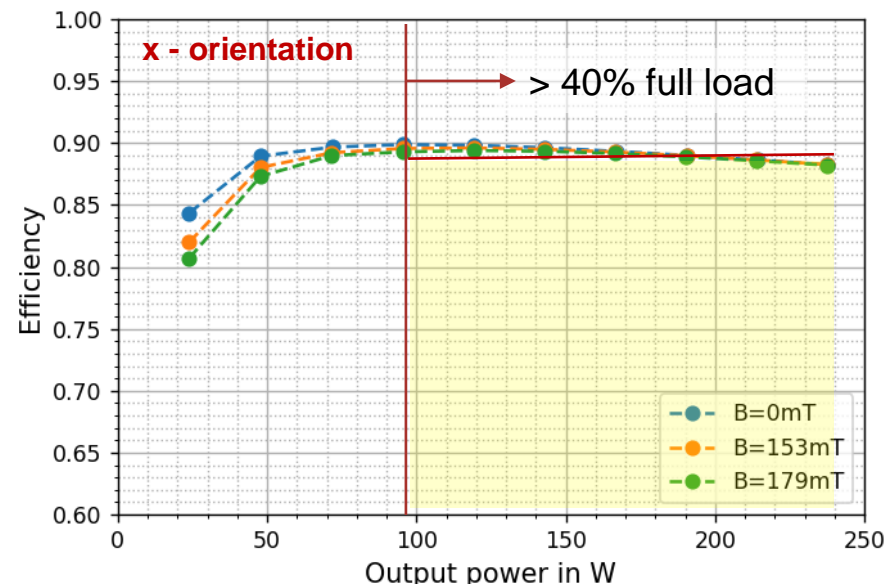
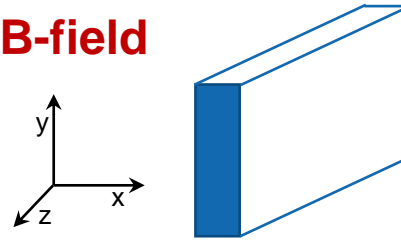

Output voltage variability – spikes, oscillations?

Method

- ‘High speed’ sampling of (DC) voltages
- 40kS/s, 20ms, 800 samples
- Plot stdev of output voltage

Conclusions

- Partial saturation of LLC transformer core
 - lower inductance
 - higher currents
 - increased losses in switching transistors
- Output converter PWM regulation instabilities resulting in oscillations

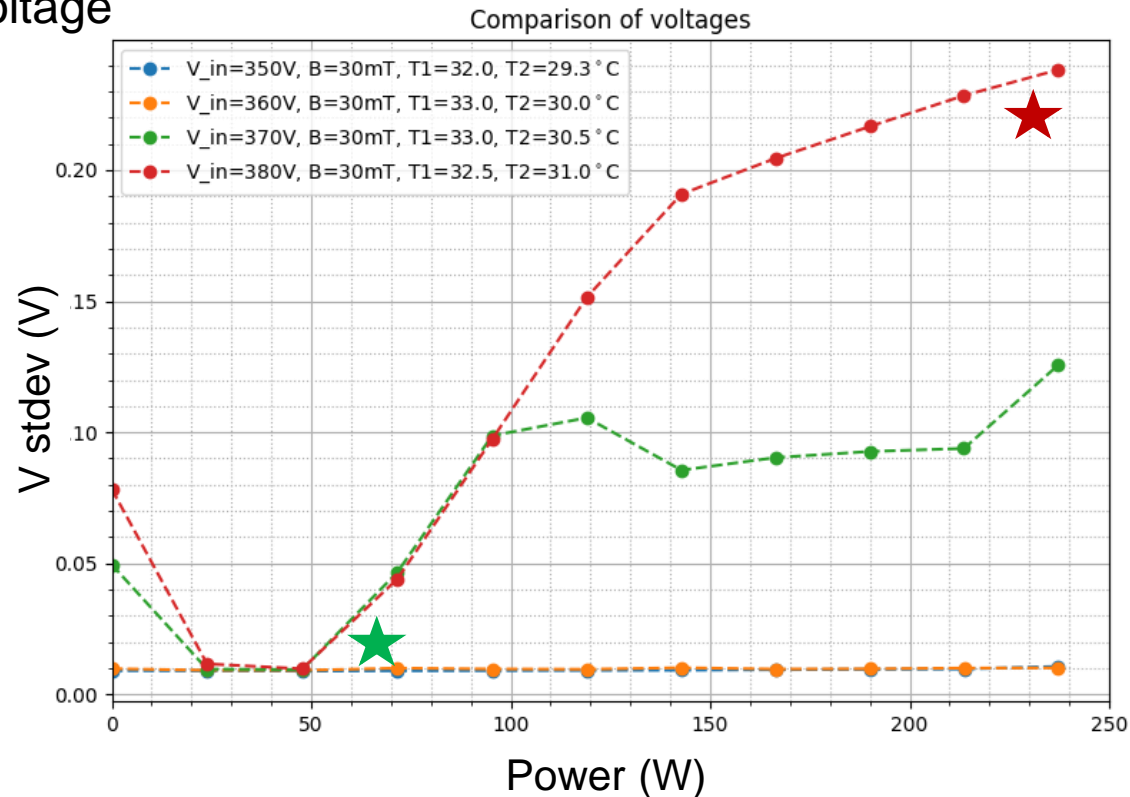

★ Expected

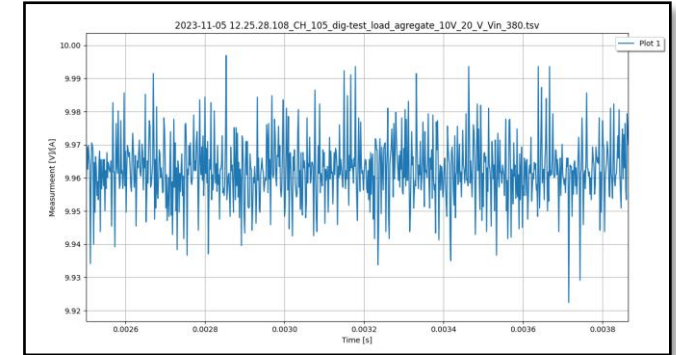

★ Oscillation

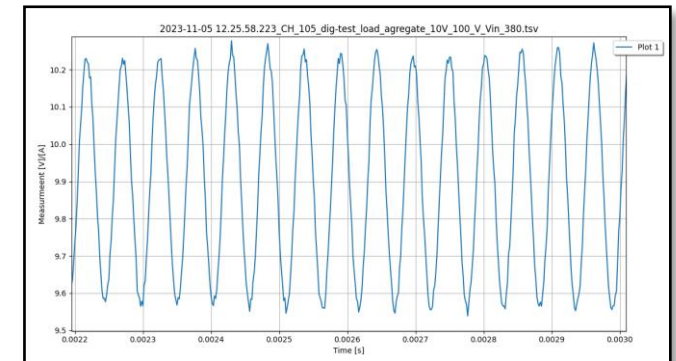

LLC intermediate voltage power transformer insufficiently shielded.

- Shield 5mm high purity iron not annealed

Magnetic shield simulations

COMSOL Multiphysics used for simulation

Shield – saturation? → NO

- 5mm thick high purity iron
- Peak flux density $\sim 1.8\text{T}$ at $\sim 120\text{mT}$ external field

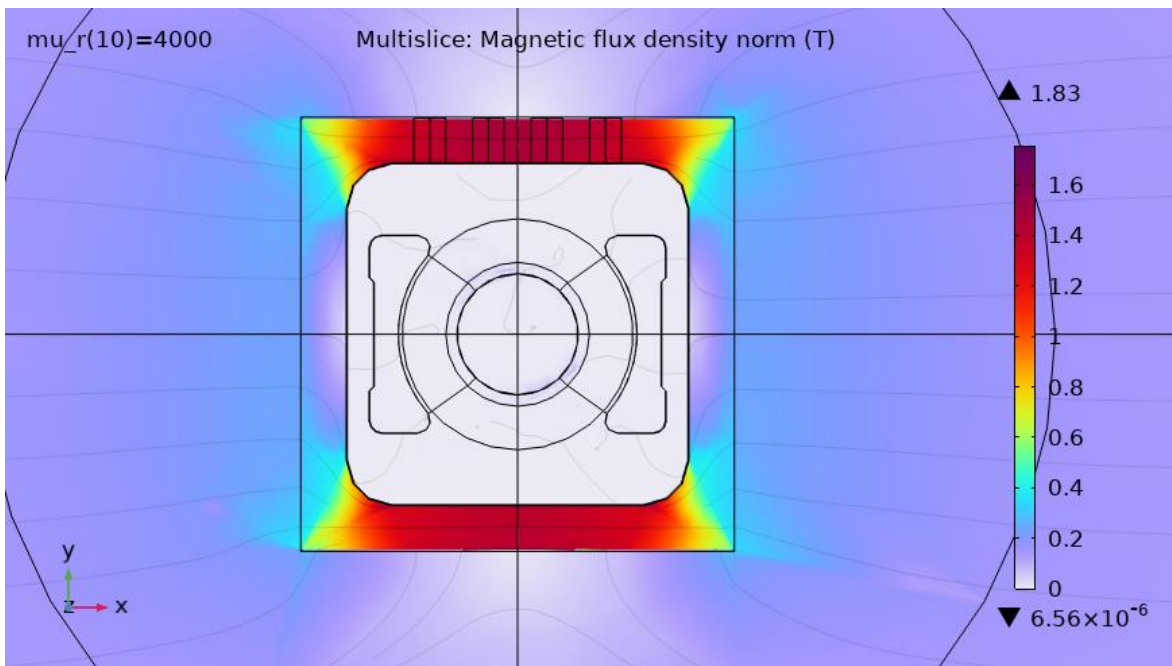
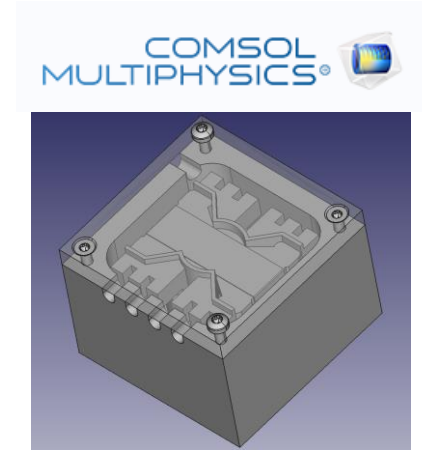

Flux penetration into inductor core? → YES

- Core relative permeability: $\mu_r \sim 3000$
- Shield no annealing: $\mu_r < 2500$

Mitigation

- Separate B-field tests by Wiener in Feb. 2024
→ Same shielding material different machining (milled)
- Extended duty-cycle range of the PWM circuitry preventing oscillations.

Summary

Long journey

- Not yet completed
- Some interesting findings
- Deeper understanding of the power supplies
- Excellent Progress

We are optimistic for Prototype-III

- To pass irradiation testing at CHARM
- To pass magnetic field testing in Goliath

We thank

- Kontron HARTMANN-WIENER and their collaborators providing subsystems and power supply prototypes for testing, carrying out some of the tests, participating in some of the test and performing the analysis of failures.
- Ashley Churchman, Michael Dröge and Christian Haller for preparation of test-setups cabling and their installation in the test areas.
- Tomasz Gadek for providing consultancy and advice.

Dr. Werner Luster
Werner.Luster@cern.ch

ETH Zurich
Institute for Particle Physics and Astrophysics
HPK D29
Otto-Stern-Weg 5
8093 Zurich, Switzerland

ipa.phys.ethz.ch

c/o CERN
PH Department
1211 Geneva 23, Switzerland

Additional material

Subsystem radiation testing – CHARM July 2023

Re-check problems found in CHARM Aug 2022

- CAN communication loss → auto-recovery not working
 - CAN configuration in RAM checked
 - Reloaded from flash in case of failure

Methods

- Count lost frames
- Monitor CAN recovery counter:

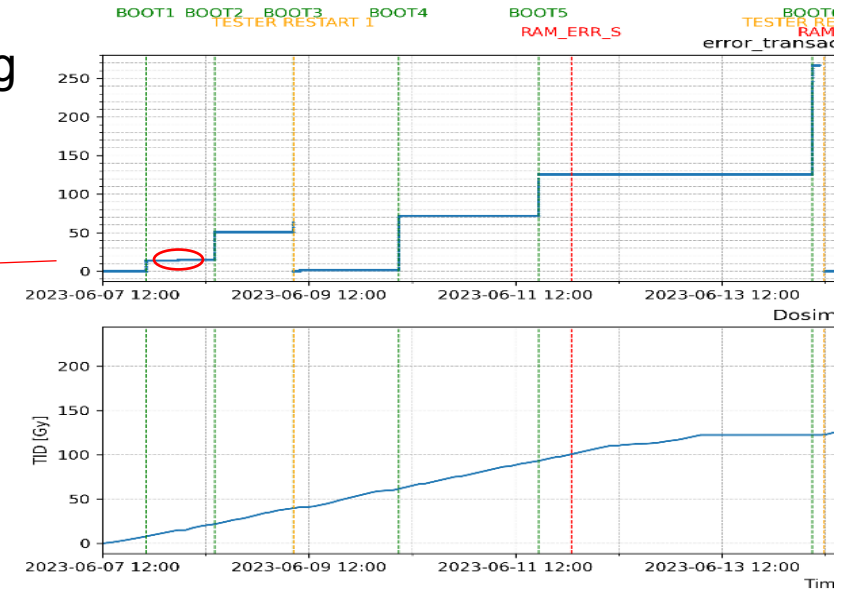
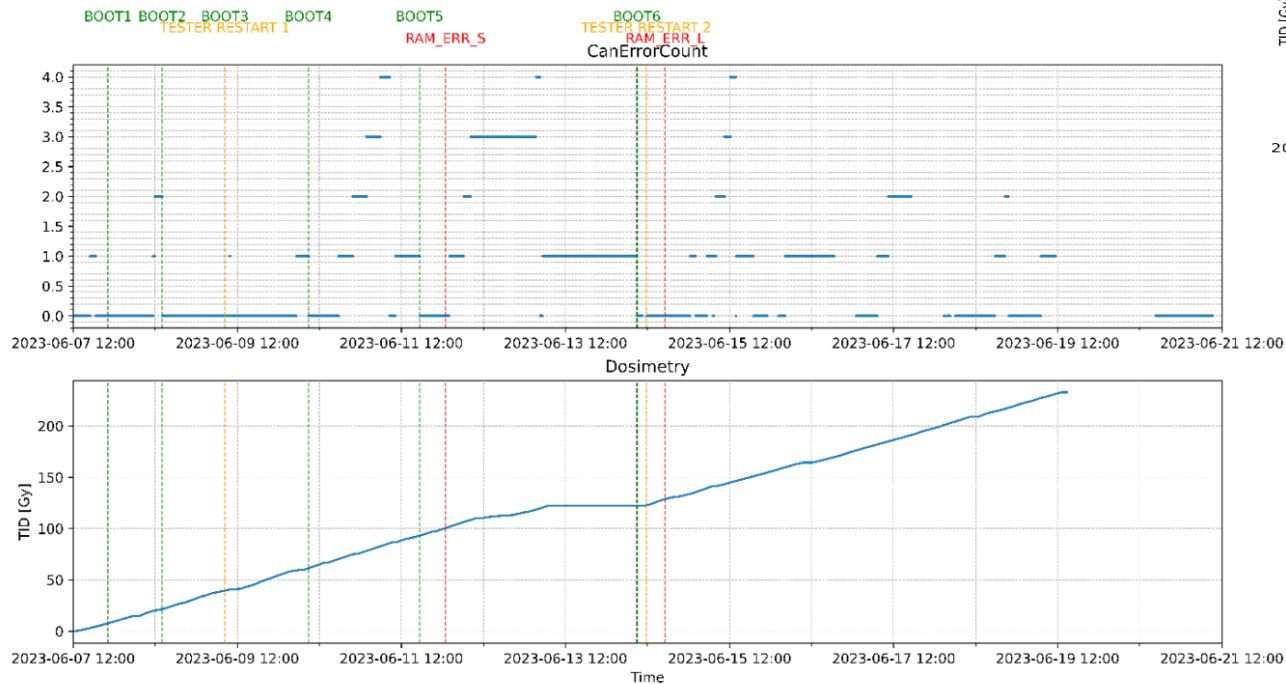

Results

- Microcontroller communication: 1 frame/second for 1 full week → 1 lost frame
- CAN configuration recovery working as expected

Prototype: improvements

Current ramp down when Interlock is set

CHARM June 2024

