

**TRACK:** Module, PCB and Component Design

**Authors:** C. Maggio (CAEN SpA), F. Giordano (CAEN SpA), T. Williams (Picotech SAS)

## Picosecond timing performances of the FERS time unit

### Abstract:

High-precision time measurements are the latest trend for experiments and PET applications. Compactness, scalability and applicability to thousands of channels is required for the readout electronics.

CAEN A5203 board, part of a synchronizable and distributable Front-End Readout System (FERS), integrates the CERN picoTDC ASIC on a small unit for high-resolution time measurements of ToA and ToT.

This poster presents the performance of the A5203 unit, in terms of time resolution, walk correction, background reduction and signal amplitude reconstruction. The results of its application to the Picotech PET system are also included.

### Summary:

Next generation high energy physics experiments will include high-demanding detectors in terms of readout channels number, thus requiring low power, low cost and reduced dimensions readout electronics. This is achieved with the CAEN Front-End Readout System 5200 (FERS 5200) ASIC-based readout modules.

FERS 5200 is a distributed and scalable family of products performing front end operations in small units, that can be used individually or combined for larger readout systems. Data acquisitions from thousands of channels can be performed thanks to the DT5215 Concentrator board, that takes care of managing and synchronizing up to 128 FERS-5200 units, as if it were a single DAQ system. FERS-5200 family is completed by a set of accessories, that permits its high flexibility for applications.

Open-source software is available for the configuration of FERS-5200 units and data acquisition.

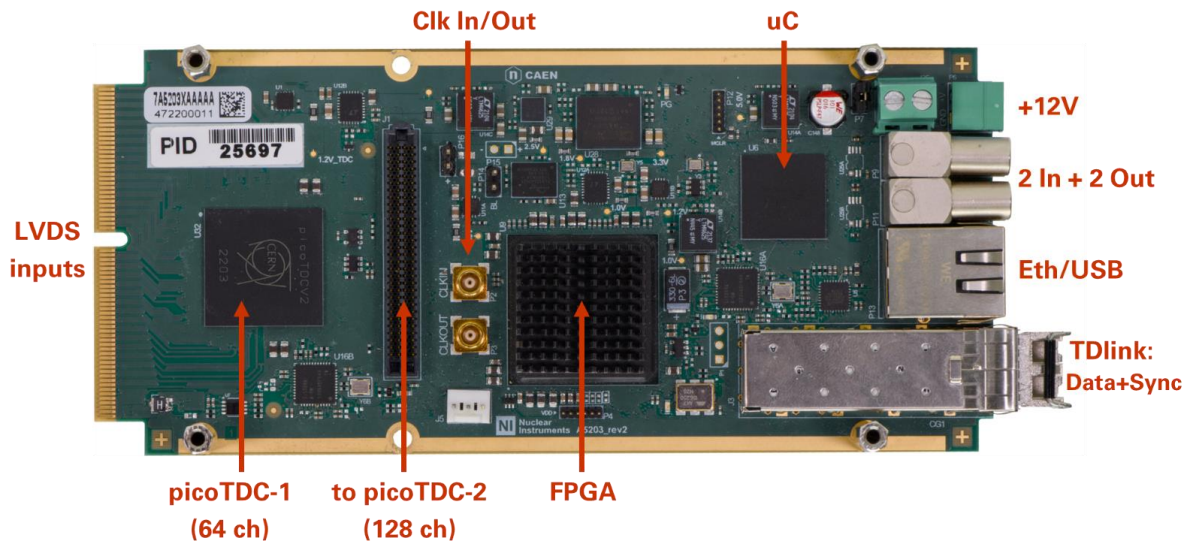
We want here to focus on the performances of the A5203 unit, housing the recently released CERN picoTDC chip (Fig. 1). With its 3.125 ps LSB, Time of Arrival (ToA) measurements can achieve down to ~7 ps RMS over a single board, with no change in the input signal amplitude, and ~20 ps RMS for input signals of variable amplitude (Fig. 2). The walk effect introduced with the different amplitudes is corrected via the Time over Threshold (ToT) at software level, with no need of a Constant Fraction Discriminator (CFD) filter. ToT is also used for signal amplitude reconstruction and background reduction.

Optimal performance of the A5203 unit has been demonstrated with its use in the Picotech Provision PET scanner, employed for the early detection of aggressive prostate cancer. Two detectors of 768 channels each are read out by 12 A5203B boards (Fig. 3). The boards are configured, synchronized and read out thanks to a DT5215 concentrator board, and work in continuous acquisition mode (no trigger needed) with no dead time. A ToT filter ( $ToT < 60$  ns), implemented in the software, eliminates the low energy noise (Fig. 4).

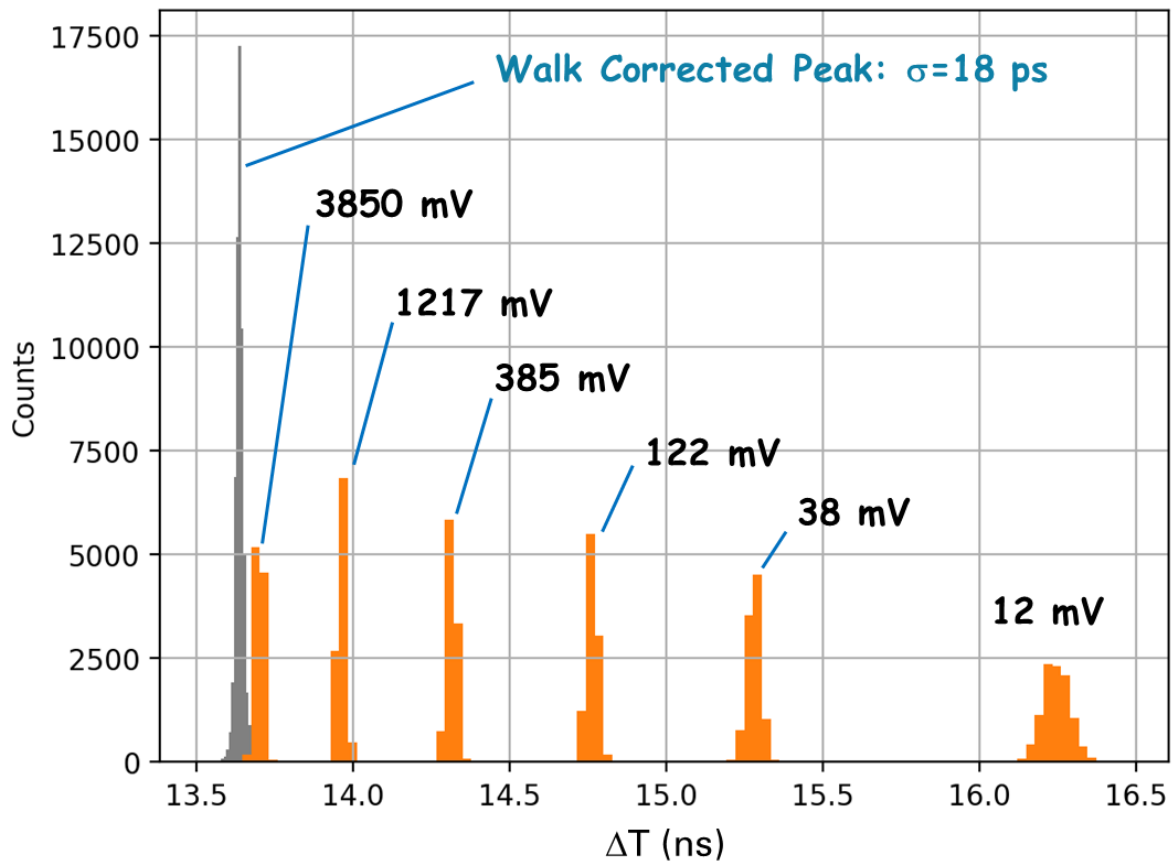
ToT and ToA measurements with the A5203 are needed to determine the position of interaction of the annihilation photon inside the detector as well as the energy deposited. Thanks to the picoTDC high-resolution timing, the achieved distance resolution is less than 2 mm, and  $^{22}\text{Na}$  radioactive sources at 6 mm distance one from the other can be clearly distinguished (Fig. 5).

To summarize, the FERS A5203 unit is part of the new generation of TDCs. It permits high-resolution time measurements of ToA and ToT of input signals, with no need for CFD filters. Reaching down to 3.125 ps resolution, it perfectly matches tens of ps resolutions of the state-of-the-art radiation detector crystals and detectors. It can be used to read data from 64/128 channels in a single board, or from thousands of channels thanks to the multi-board synchronization via the DT5215. It can be, then, called a valuable substitute for old TDC units, flexible, scalable, and cost-effective.

Figures:

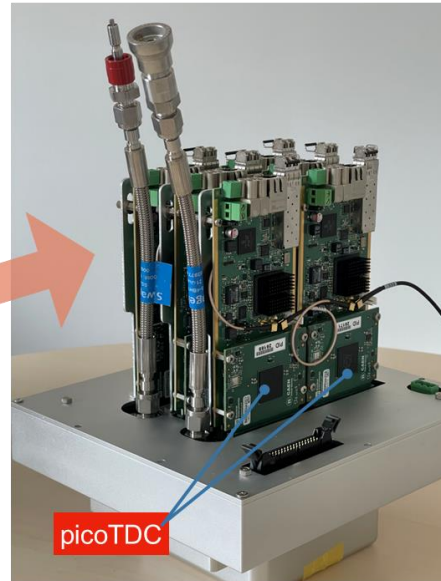
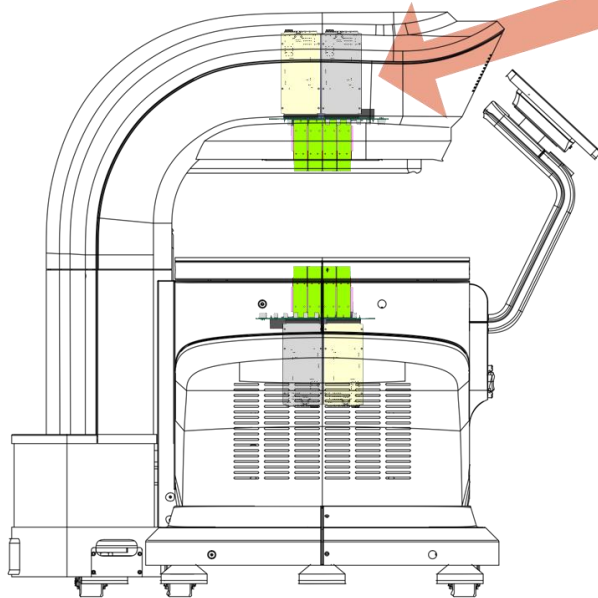


**Fig.1** General view of the A5203 FERS unit, where the principal components and connectors are indicated.

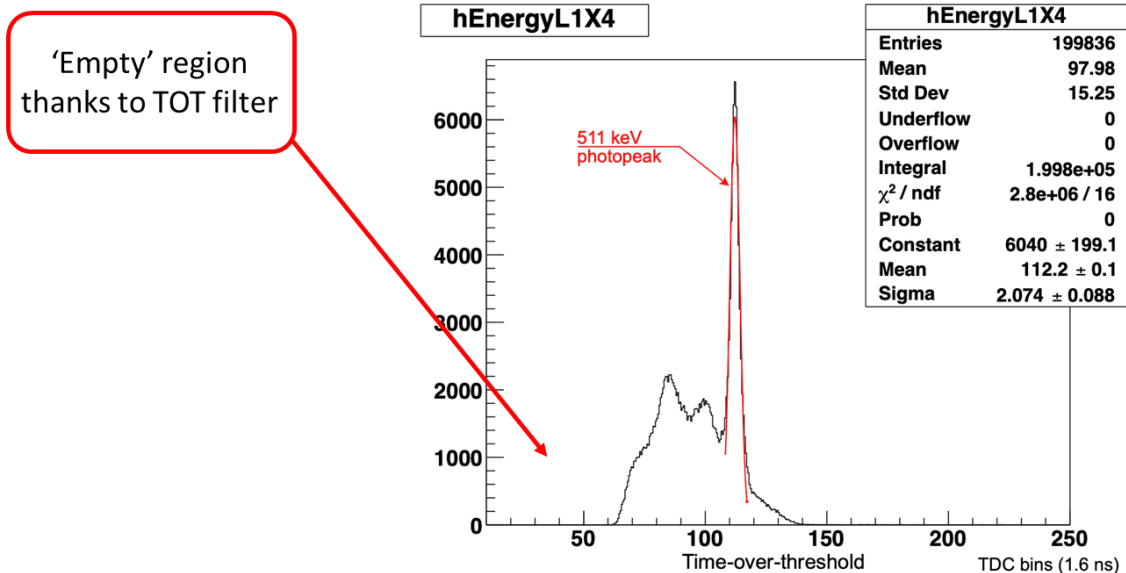


**Fig.2** ToA measurements of input signals at different amplitudes before (orange) and after (grey) walk correction.

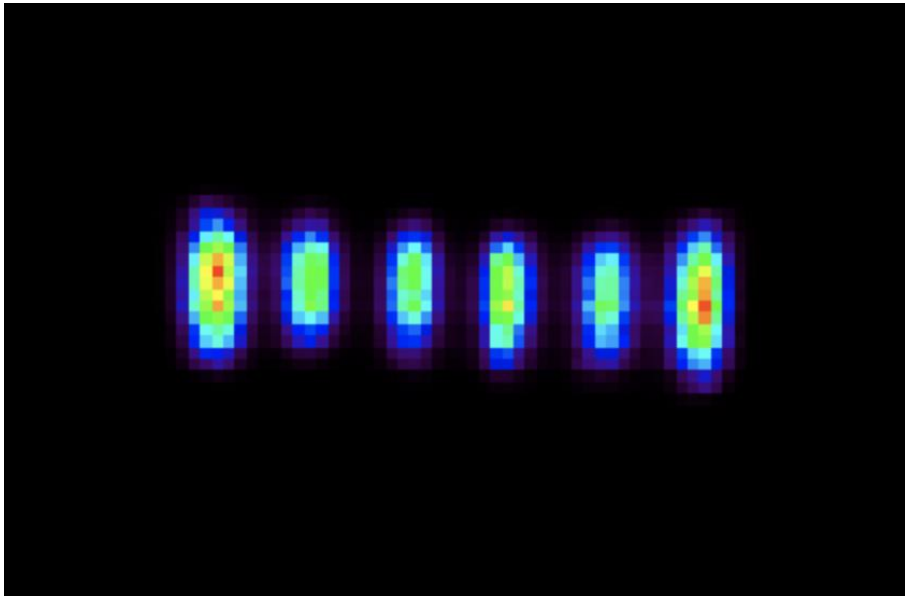
## Picotech 'ProVision' PET scanner



**Fig.3** Positioning of A5203 units inside the ProVision PET scanner.



**Fig.4** Na22 spectrum obtained via A5203 ToT measurements (ToT resolution of 1.6 ns). Noise reduction thanks to event suppression based on ToT threshold.



**Fig.5** Coronal view of a stack of 6 Na22 sources obtained during tests of the Picotech PET scanner.