

# Ideas for $HHH \rightarrow 4b2\tau$

HHH Workshop 2025

---

Gabriel Oliveira Corrêa,  
*on behalf of the ATLAS Collaboration*

Institut de Física d'Altes Energies, Barcelona

September 29, 2025



# Introduction

- As we all know, the HHH search is a lot of fun.
  - Not going over the motivation, since we have all the other talks in this workshop.

# Introduction

- As we all know, the HHH search is a lot of fun.
  - Not going over the motivation, since we have all the other talks in this workshop.
- Many analyses currently probe the Higgs self-interaction:
  - $HH$  sets the main constraints in  $\kappa_3$ .
  - $HHH \rightarrow 6b$  and  $HHH \rightarrow 4b2\gamma$  sets the main constraints in  $\kappa_4$ .

[2411.02040](#)

[2301.03212](#)

- Largest SM BR.
- Larger SM bkg.
- Large QCD bkg.

$HH \rightarrow bbbb$

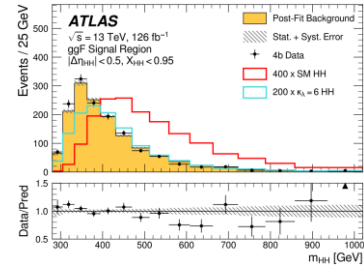

$HHH \rightarrow bbbbbb$

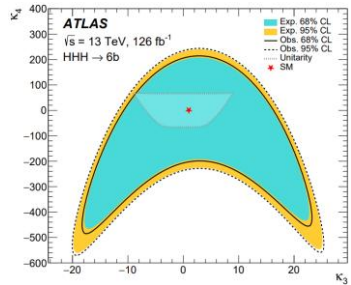

$HH \rightarrow bb\gamma\gamma$

[CMS-PAS-HIG-24-015](#)

[2507.03495](#)

- Very rare process.
- Very clean signal.

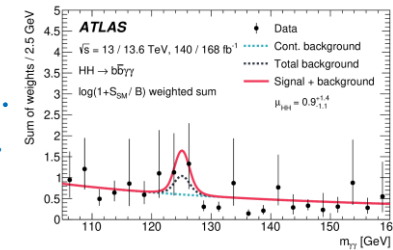

$HHH \rightarrow bbb\gamma\gamma$

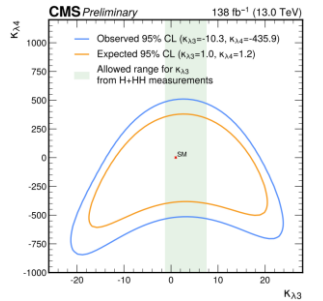

$HH \rightarrow bb\tau\tau$

[2209.10910](#)

- Large BR.
- Bkg mostly  $t\bar{t}$ .
- Low QCD bkg.

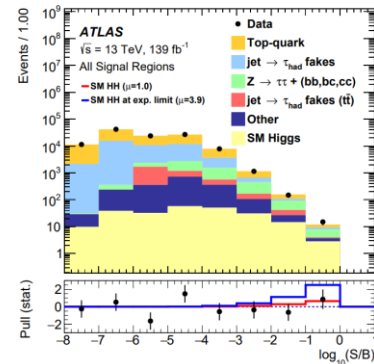

# Introduction

- As we all know, the HHH search is a lot of fun.
  - Not going over the motivation, since we have all the other talks in this workshop.
- Many analyses currently probe the Higgs self-interaction:
  - HH sets the main constraints in  $\kappa_3$ .
  - HHH $\rightarrow$ 6b and HHH $\rightarrow$ 4b2 $\gamma$  sets the main constraints in  $\kappa_4$ .
- An obvious candidate for the next HHH search is 4b2 $\tau$ .
  - Large branching ratio (6.2%):  
BR(HHH  $\rightarrow$  4b2 $\tau$ ) / BR(HHH  $\rightarrow$  6b) is higher than  
BR(HH  $\rightarrow$  2b2 $\tau$ ) / BR(HH  $\rightarrow$  4b).
  - Low multijet background.
- In this talk I will discuss from an experimental point of view how a HHH  $\rightarrow$  4b2 $\tau$  search would look like by showing other public analyses from the ATLAS Experiment.

[2411.02040](#)

[2301.03212](#)

- Largest SM BR.
- Larger SM bkg.
- Large QCD bkg.

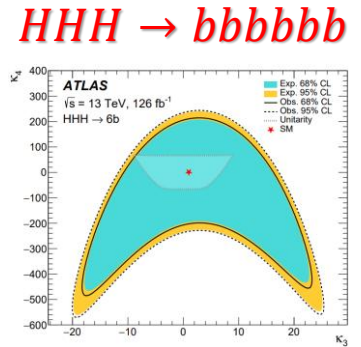
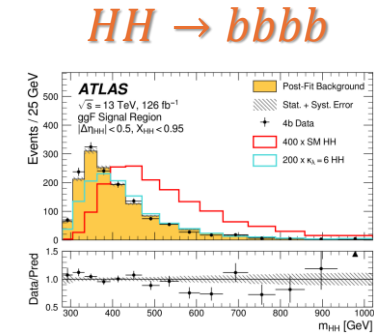

**HH  $\rightarrow$  bb $\gamma\gamma$**

[CMS-PAS-HIG-24-015](#)

[2507.03495](#)

- Very rare process.
- Very clean signal.

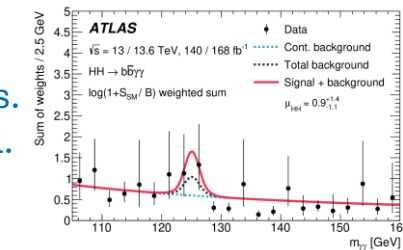

**HHH  $\rightarrow$  bbbb $\gamma\gamma$**

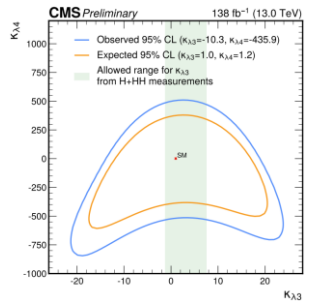

**HH  $\rightarrow$  bb $\tau\tau$**

[2209.10910](#)

- Large BR.
- Bkg mostly  $t\bar{t}$ .
- Low QCD bkg.

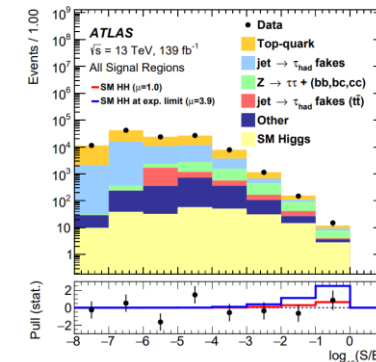

Next:  
HHH  $\rightarrow$  4b2 $\tau$   
?

# How does a $4b2\tau$ analysis looks like?

To maximize the signal acceptance, we should consider the  $\tau_{had}\tau_{had}$  and  $\tau_{lep}\tau_{had}$  channels.

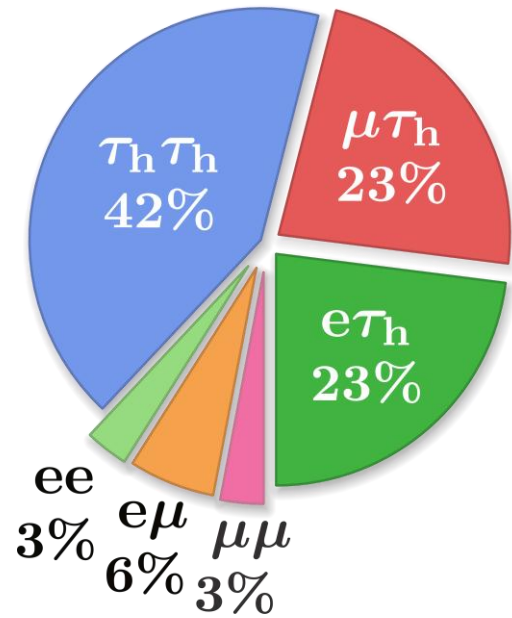

# How does a $4b2\tau$ analysis looks like?

To maximize the signal acceptance, we should consider the  $\tau_{had}\tau_{had}$  and  $\tau_{lep}\tau_{had}$  channels.

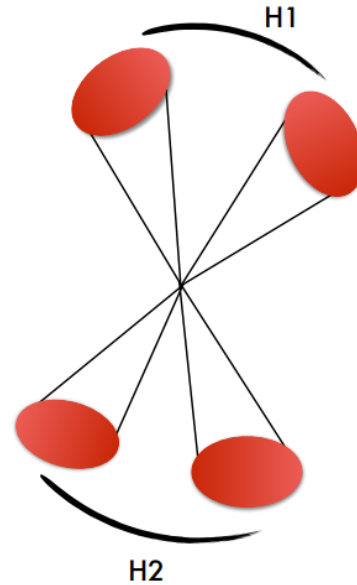
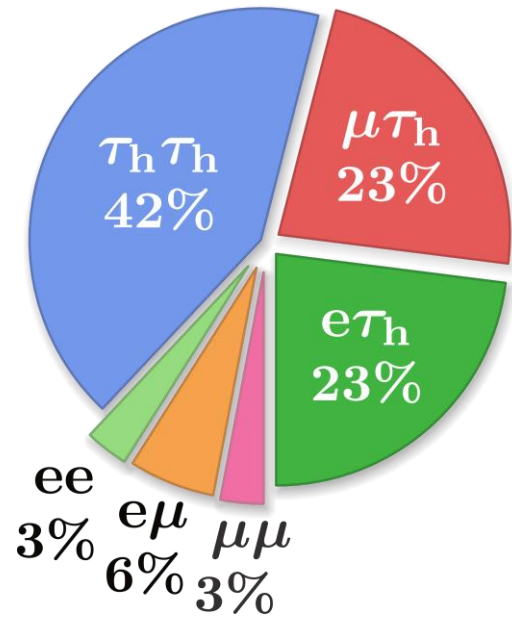

We have four b-quarks to pair:

- We should assign them as best as we can to reconstruct H/HH/HHH.
- Our b-tagging algorithms are not perfect; we should consider both 3b and 4b final states.

# How does a $4b2\tau$ analysis looks like?

To maximize the signal acceptance, we should consider the  $\tau_{had}\tau_{had}$  and  $\tau_{lep}\tau_{had}$  channels.

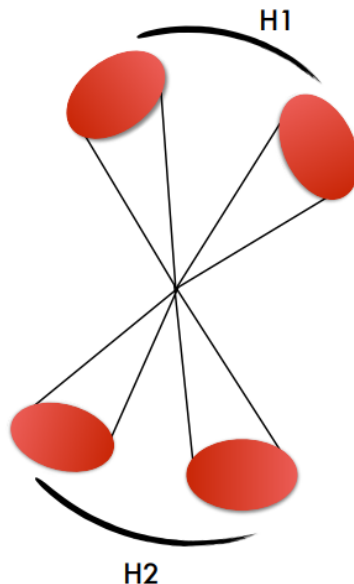
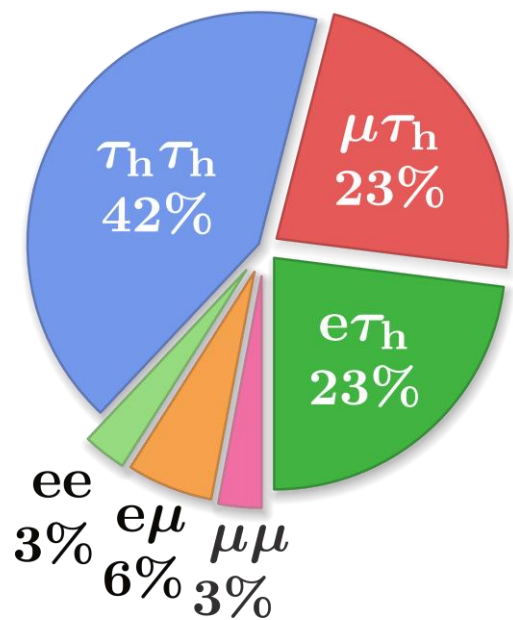

We have four b-quarks to pair:

- We should assign them as best as we can to reconstruct  $H/HH/HHH$ .
- Our b-tagging algorithms are not perfect; we should consider both  $3b$  and  $4b$  final states.

Final state with many objects with tricky acceptance, needs creativity when using triggers.

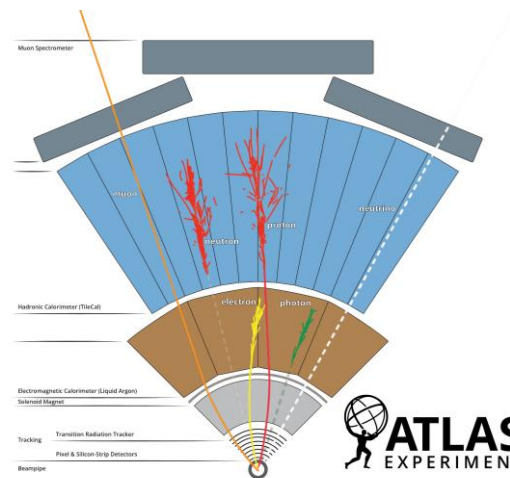

# How does a $4b2\tau$ analysis looks like?

To maximize the signal acceptance, we should consider the  $\tau_{had}\tau_{had}$  and  $\tau_{lep}\tau_{had}$  channels.

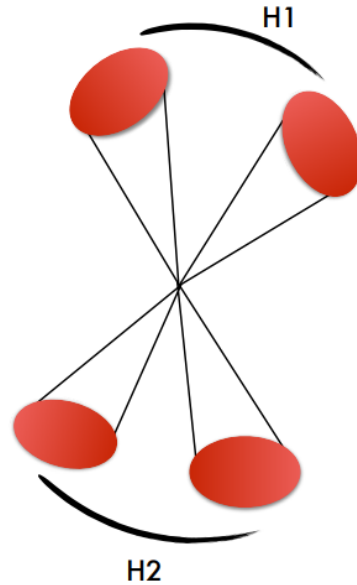
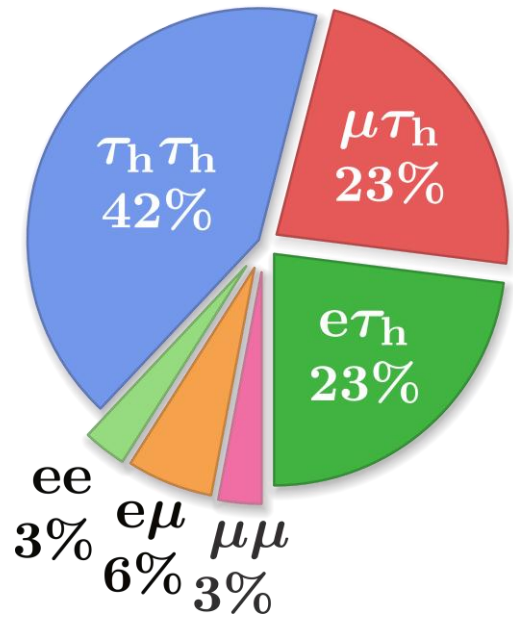

Final state with many objects with tricky acceptance, needs creativity when using triggers.

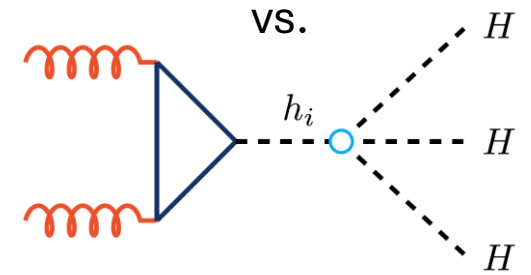
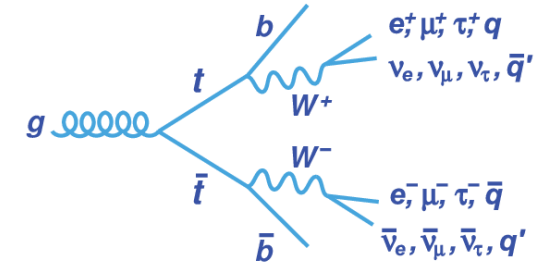

We have four b-quarks to pair:

- We should assign them as best as we can to reconstruct  $H/HH/HHH$ .
- Our b-tagging algorithms are not perfect; we should consider both  $3b$  and  $4b$  final states.

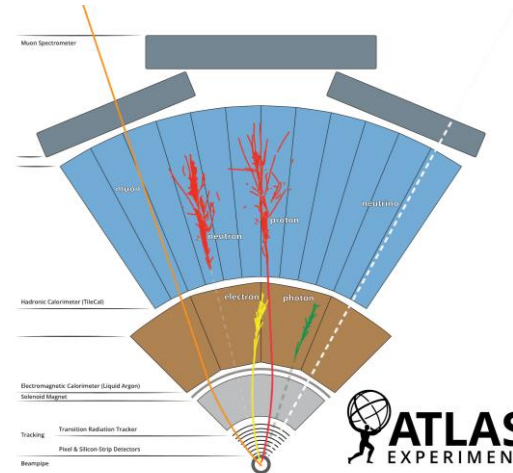

No single variable will give a good sensitivity. A neural network is going to be needed for a discriminating variable. Good background modeling is essential.

# How does a $4b2\tau$ signal region looks like?

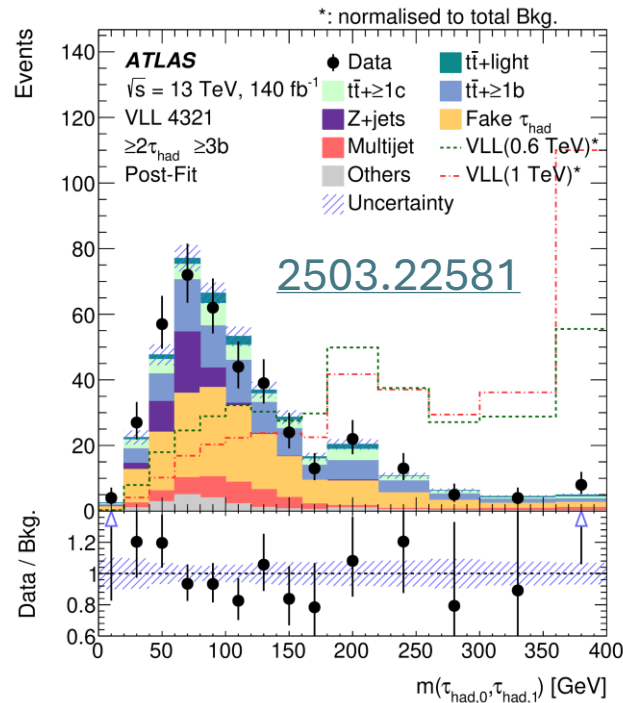

## An example from a BSM search

- Search for Vector-Like Leptons (VLLs) in Run 2 included a SR with at least  $2\tau_{had}$  (mainly  $2\tau_{had}OS$ ), at least  $3b$ ,  $4j$ , 0 light-leptons selection, which should be very similar to the  $HHH \rightarrow 4b2\tau$  SR.
- Uses a trigger bucket strategy that includes MET, single-tau, and di-tau triggers in the  $2\tau_{had}$  channel ( $b$ -jet trigger not useful for catching VLLs in this region, but it was used in the  $1\tau_{had}$  region).

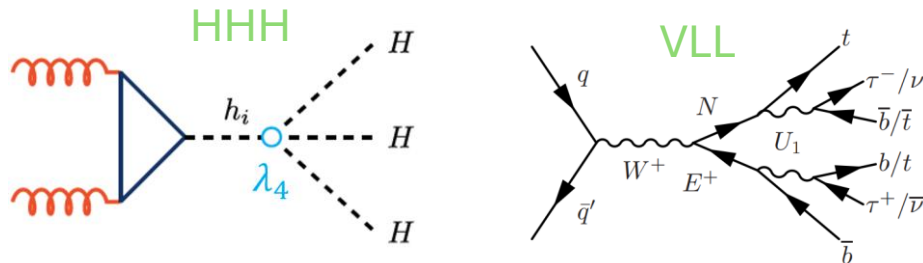

- Background mostly from  $t\bar{t}$  events.
  - Most of them including fake- $\tau_{had}$ .
- QCD multijet background estimation needed, but far from being a leading background.

- Both:  $\geq 4b$ -jets,  $\tau_{had}\tau_{had}$ ,  $\tau_{lep}\tau_{had}$ .
- HHH:  $bb$  and  $\tau\tau$  resonances, soft kinematics, little MET.
- VLLs:  $b\tau$  and  $t\nu$  resonances, hard kinematics, significant MET.

# The trigger strategy

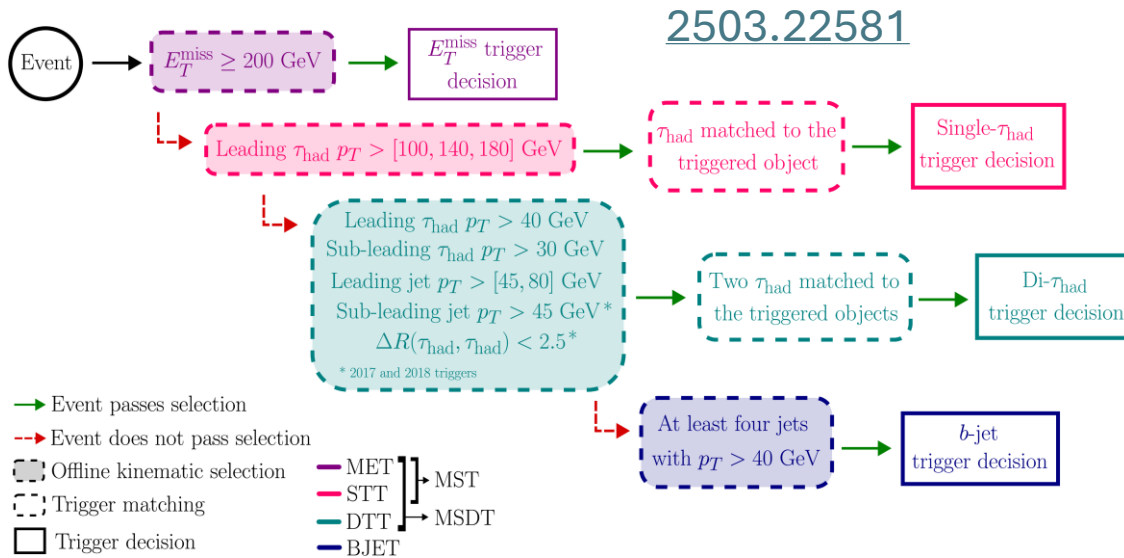

- Final states rich in taus and jets allow us to get creative with our trigger selection.
- Single-tau (STT) and di-tau (DTT) trigger are obvious choices, but their tau  $p_T$  cuts decrease the acceptance significantly.
- B-jet trigger could help recover events with low  $p_T$  taus for events with high b-jet multiplicity.

# The trigger strategy

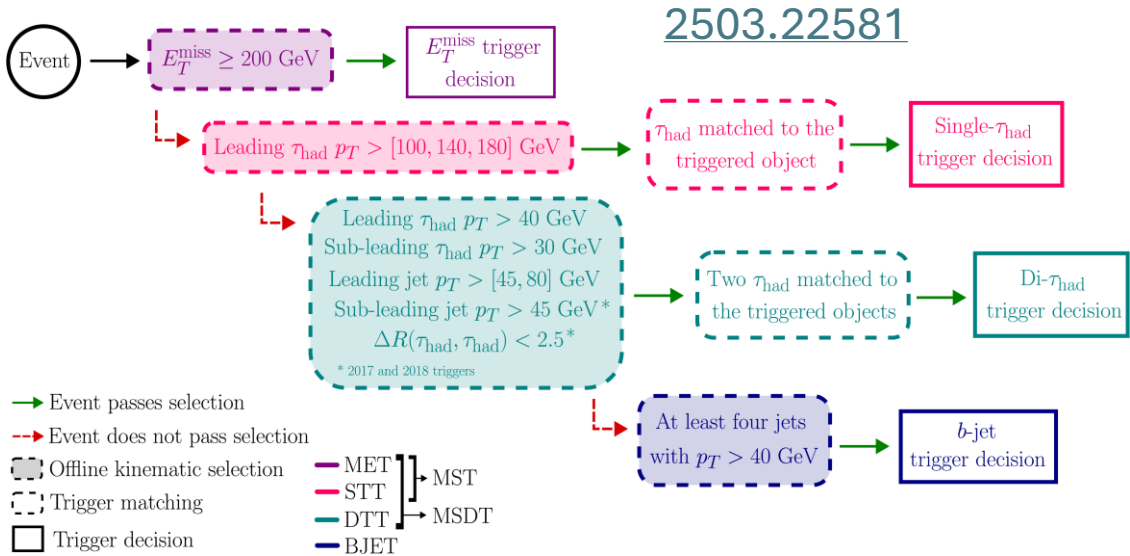

- Final states rich in taus and jets allow us to get creative with our trigger selection.
- Single-tau (STT) and di-tau (DTT) trigger are obvious choices, but their tau  $p_T$  cuts decrease the acceptance significantly.
- B-jet trigger could help recover events with low  $p_T$  taus for events with high b-jet multiplicity.

$m_{VLL}$ [GeV]	$\geq 2\tau_{had}$ MSDT SR		
	600	900	1200
$\mathcal{L} \times \sigma$	2112.8	255.9	42.5
$0\ell$	558.6	65.6	10.8
$1\tau_{had}$ (loose)	—	—	—
$\geq 2\tau_{had}$ (loose)	102.0	11.0	1.7
Final $\tau_{had}$ ID	100.7	10.9	1.7
Trigger	73.2	9.7	1.6
$N_{jets} \geq 3$	72.7	9.7	1.6
$N_{jets} \geq 4$	—	—	—
$N_{b-jets} \geq 3$	46.7	6.3	1.0
$N_{b-jets} \geq 4$	—	—	—

## VLLs ( $2\tau_{had}$ ):

- $\sim 73\% = 30\%(\text{MET}) + 23\%(\text{DTT}) + 20\%(\text{STT})$
- BJET: not worth it.

## HHH:

- Almost no neutrinos, no need for MET trigger.
- Way softer kinematics, but good S/B justifies STT.
- DTT is the main trigger and would drive the sensitivity.
- Significant acceptance gained by using jet triggers to recover events with softer tau kinematics.
  - But it comes with non-negligible QCD multijet bkg.

# Improving the trigger strategy: b-jet triggers

- The b-jet triggers in Run 2 (used in the VLL analysis):
  - 2b2j: two b-tagged jets and two additional jets with  $p_T > 35$  GeV.
- In Run 3, asymmetric triggers were added with DL1d(GN1) flavor taggers for 2022(2023):
  - 2b2j(asym):  $\geq 4$  jets with  $p_T > 80(75), 55(50), 28(25), 20$  GeV, two b-tagged.
  - Designed for the HH analyses, the gain for HHH would be similar (since also only 4b jets).

14% gain in efficiency when compared to the Run 2 triggers.

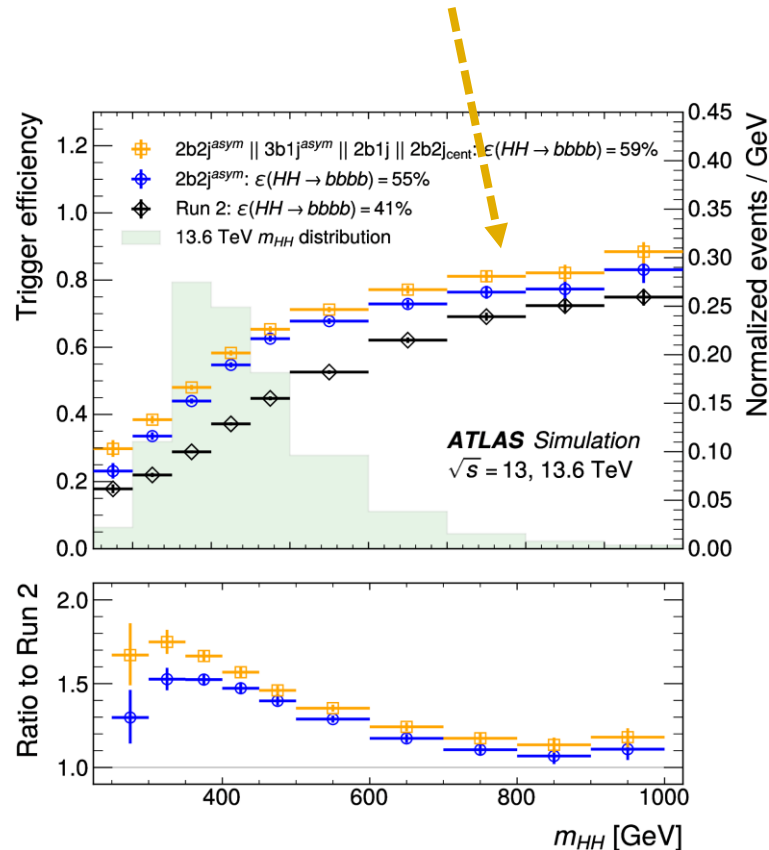

20% gain in efficiency when compared to using only the standard tau triggers.

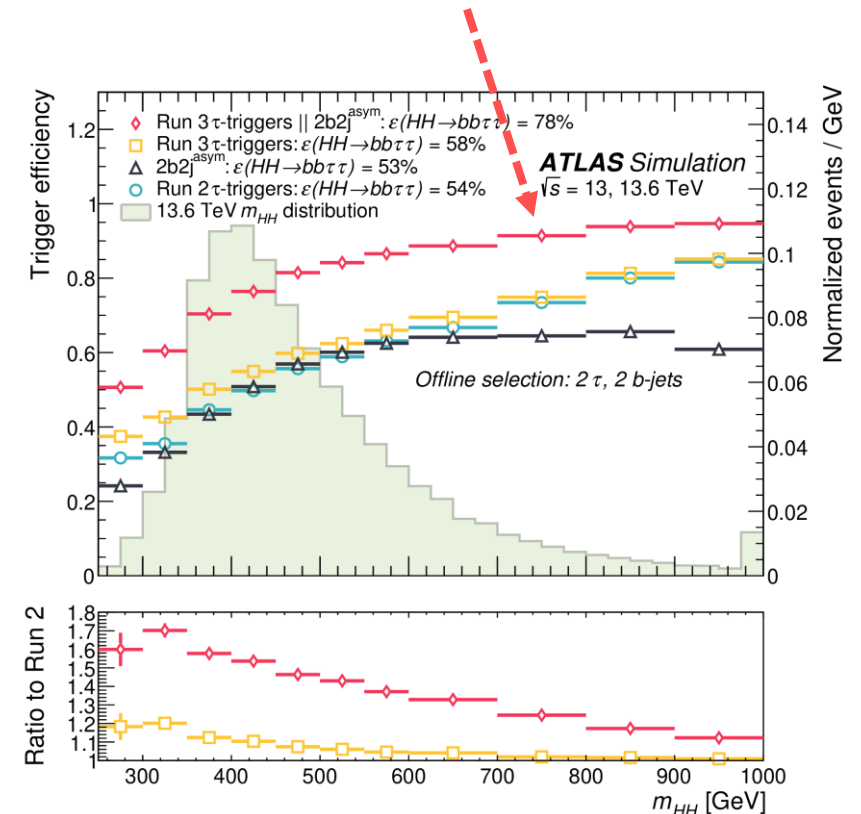

# Improving the trigger strategy: b+tau triggers

- New b+tau trigger added for 2024:
  - 1b + 1 $\tau$  + 2j: 4 jets with  $p_T > 65, 40, 25, 20$  GeV, requiring 1 b-tagged (GN1/GN2) jet, and 1 $\tau$  (RNN) with  $p_T > 25$ .
- Gain of 5% in HH signal efficiency when compared to using the previous tau/jet triggers.
- To be checked where this trigger would fall in a possible trigger bucket strategy.

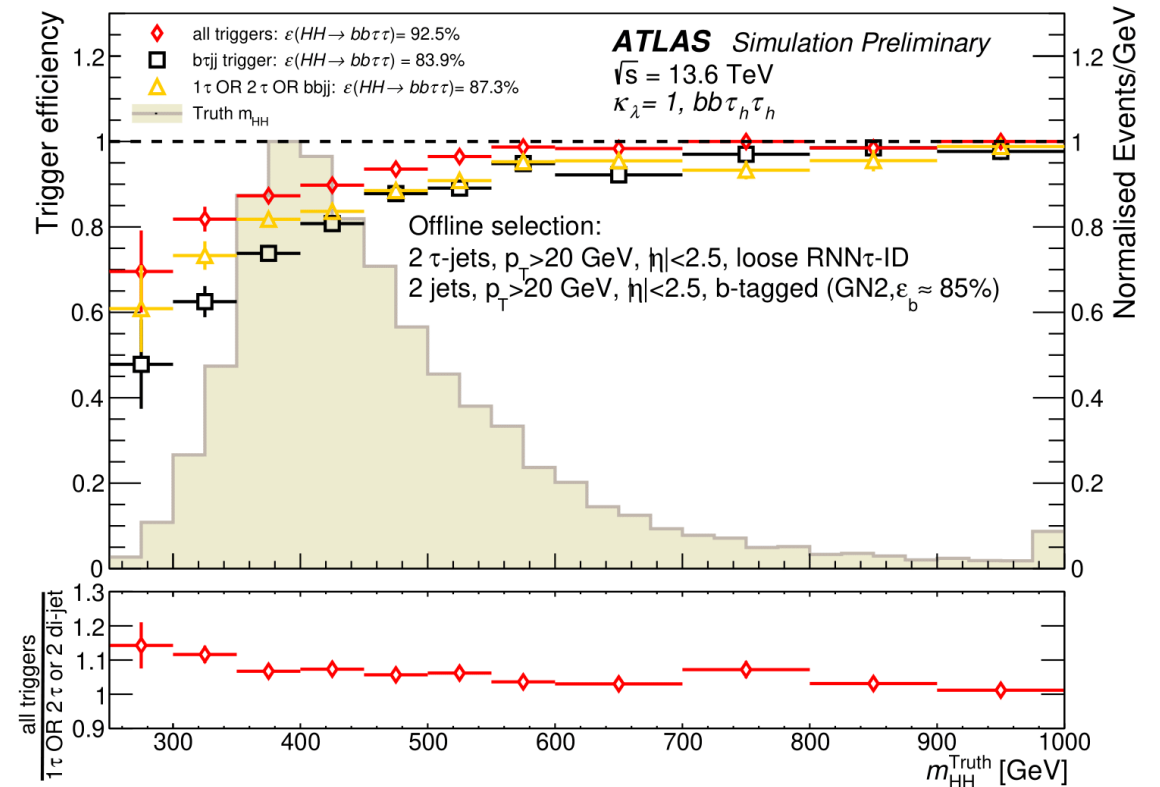

ATLAS Tau Trigger Public Results

# B-tagging

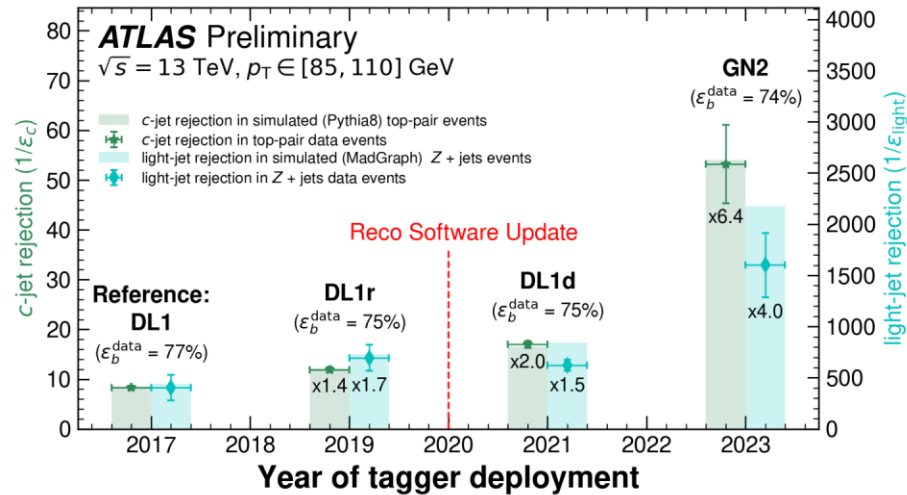

- New transformer-based tagger (GN2) improves significantly the background rejection efficiency.
- This improvement should give us the liberty of going to higher b-tagging efficiencies.
  - Also allows exploring a pseudo-continuous b-tagging as much as possible.
- An upcoming tagger (GN3) should improve these numbers even more (more on this tomorrow in Roshan's talk!).

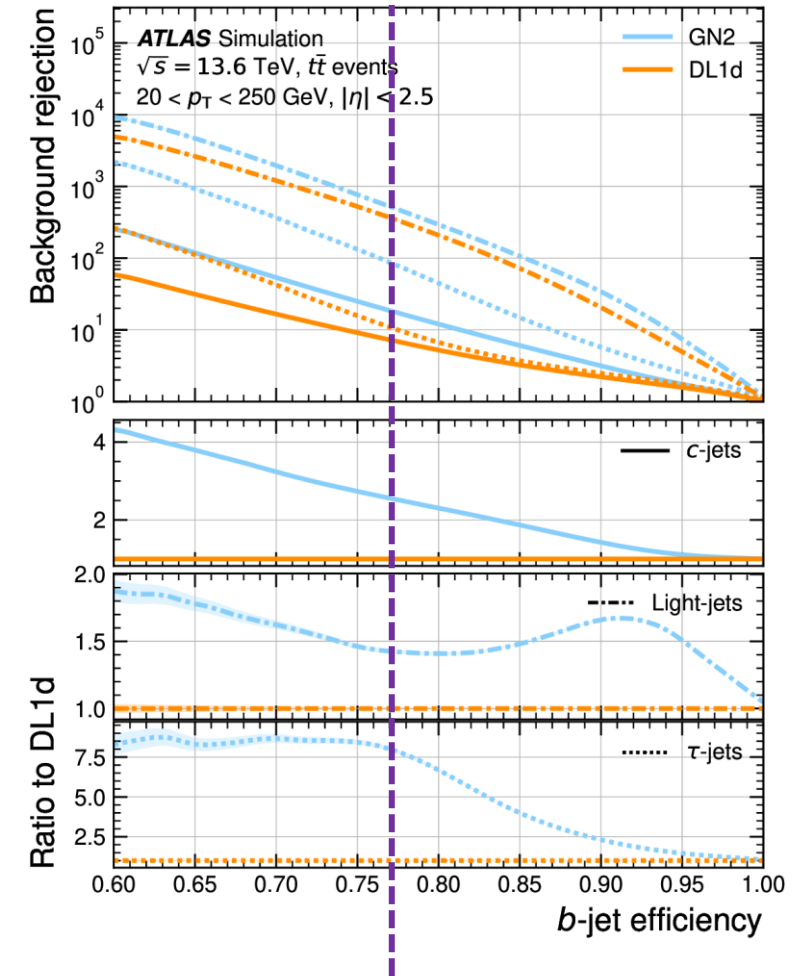

- 77% WP used by the VLL and HHH- $\rightarrow$ 6b analysis.

# Modeling the background

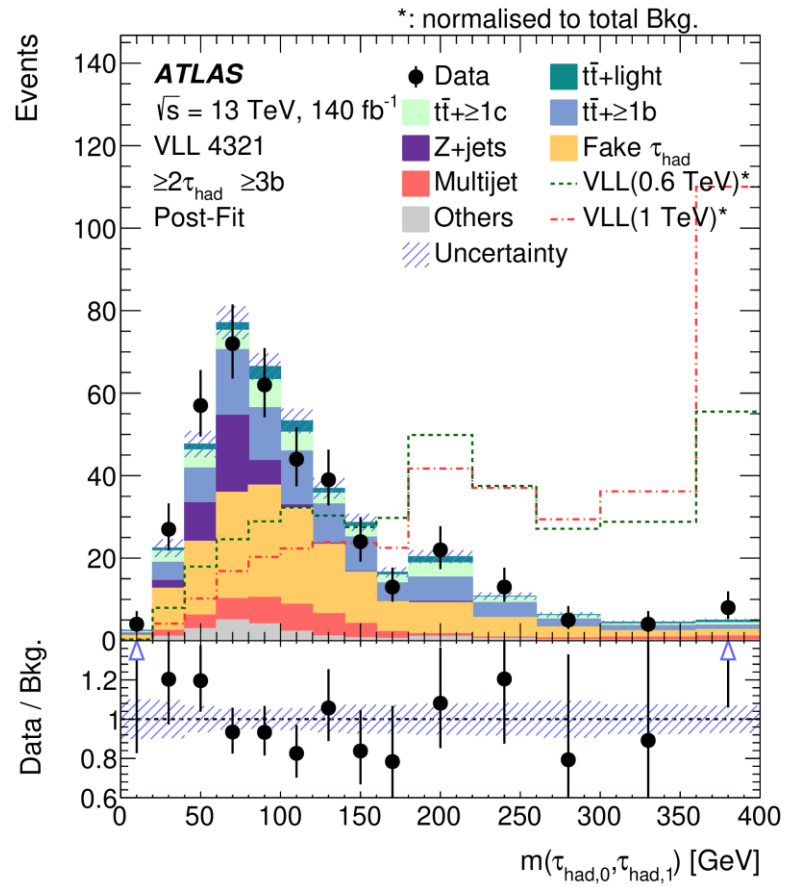

[2503.22581](#)

# The background estimation

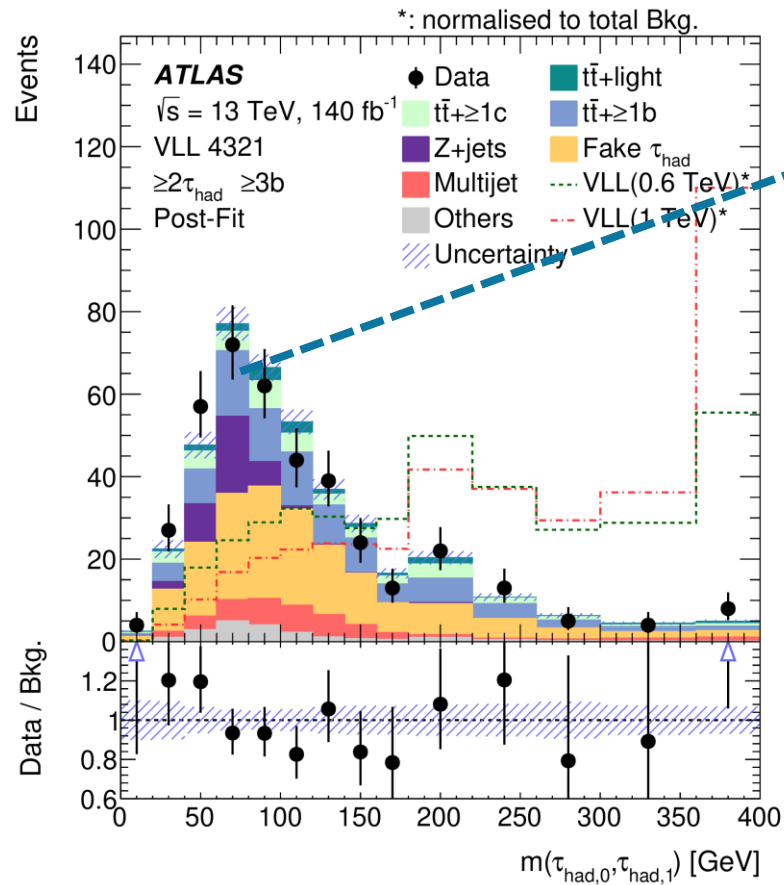

The main background with real hadronic taus is dileptonic  $t\bar{t}$  containing extra heavy-flavor jets.

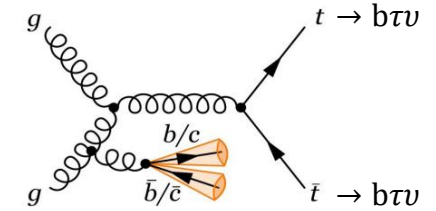

[2503.22581](https://arxiv.org/abs/2503.22581)

# The background estimation

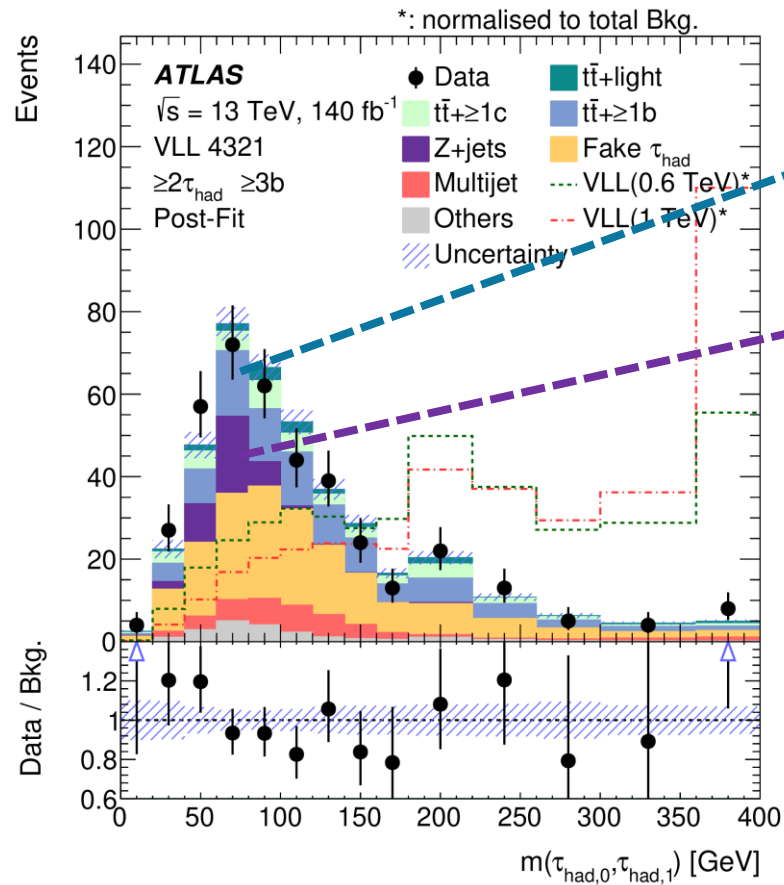

The main background with real hadronic taus is dileptonic  $t\bar{t}$  containing extra heavy-flavor jets.

$Z \rightarrow \tau\tau$  with extra heavy-flavor jets also has a sizeable contribution.

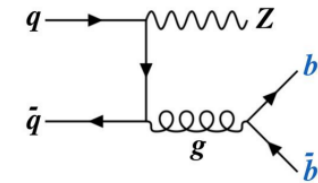
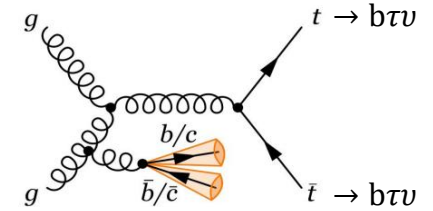

2503.22581

# The background estimation

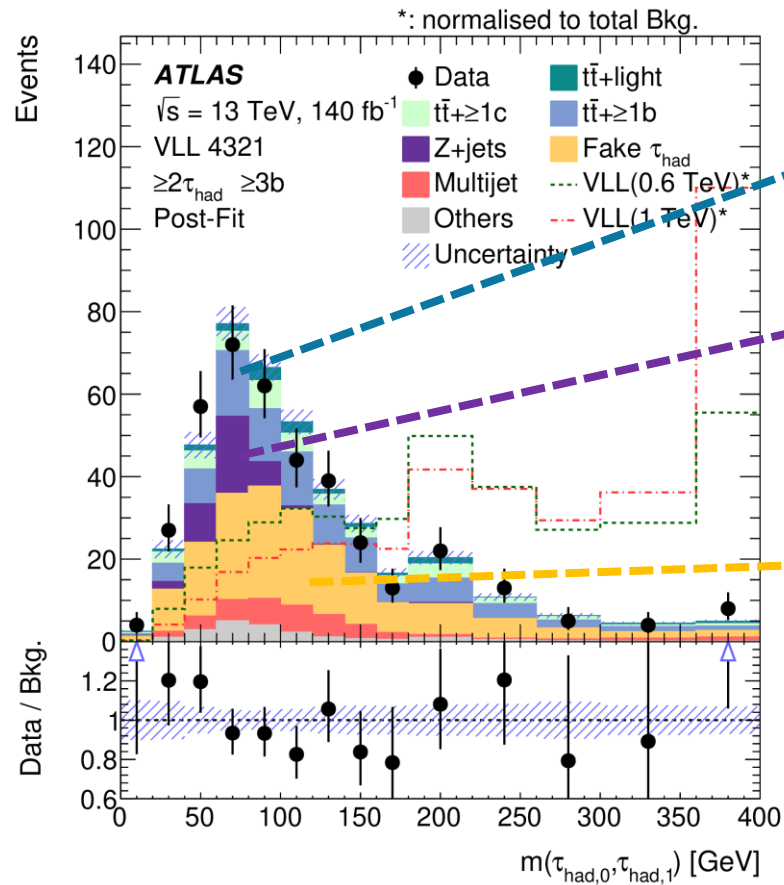

The main background with real hadronic taus is dileptonic  $t\bar{t}$  containing extra heavy-flavor jets.

$Z \rightarrow \tau\tau$  with extra heavy-flavor jets also has a sizeable contribution.

The fake hadronic tau background is mostly composed by semi-leptonic  $t\bar{t}$  (w/ extra heavy-flavor jets).

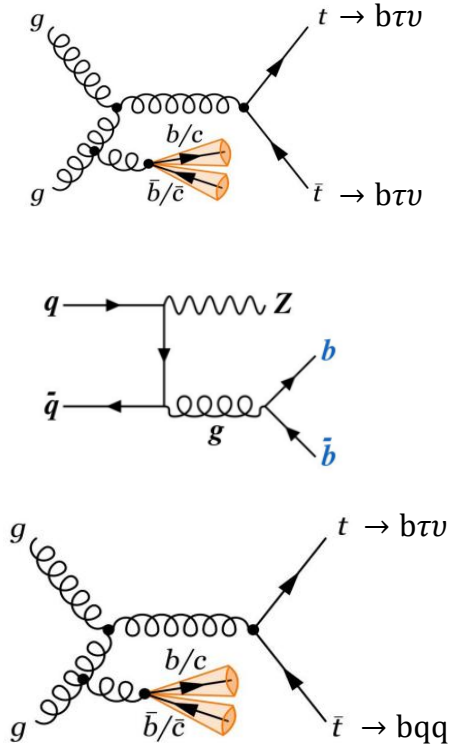

2503.22581

# The background estimation

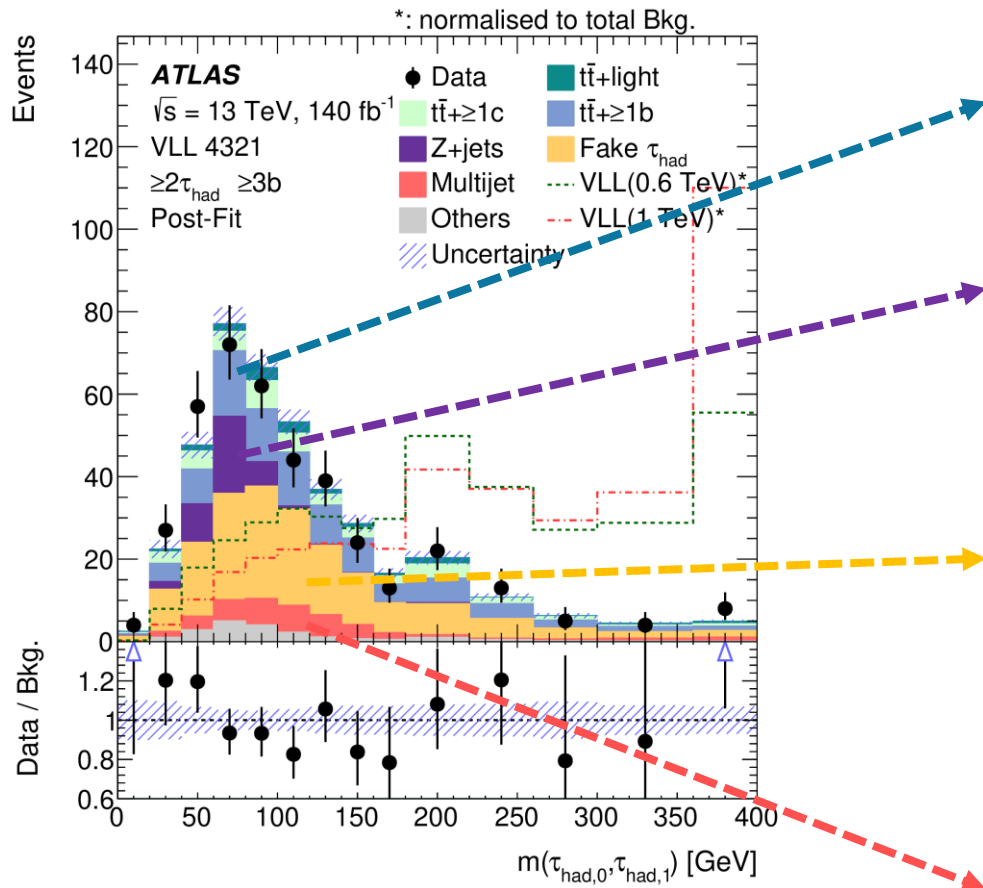

2503.22581

The main background with real hadronic taus is dileptonic  $t\bar{t}$  containing extra heavy-flavor jets.

$Z \rightarrow \tau\tau$  with extra heavy-flavor jets also has a sizeable contribution.

The fake hadronic tau background is mostly composed by semi-leptonic  $t\bar{t}$  (w/ extra heavy-flavor jets).

The other part of the fake hadronic tau background is composed by QCD multijet background events.

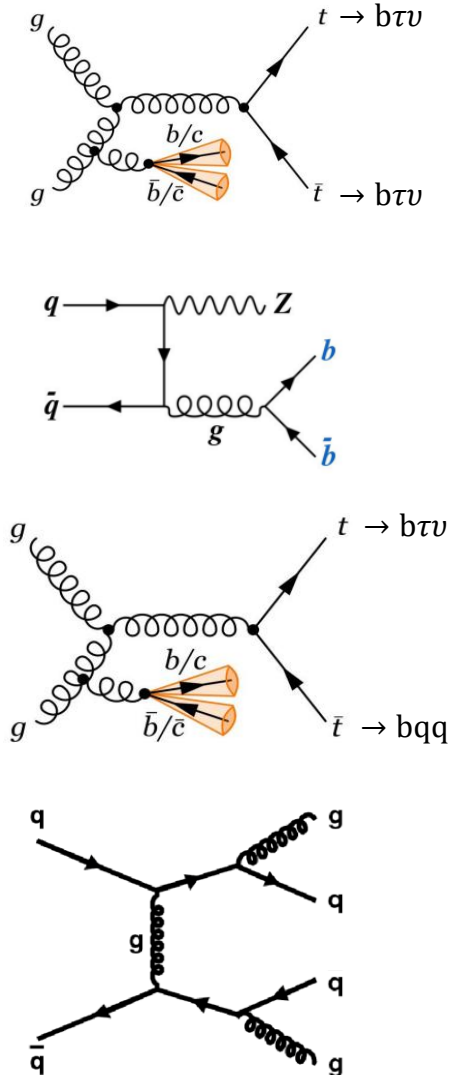

# Estimating the background: $t\bar{t}$

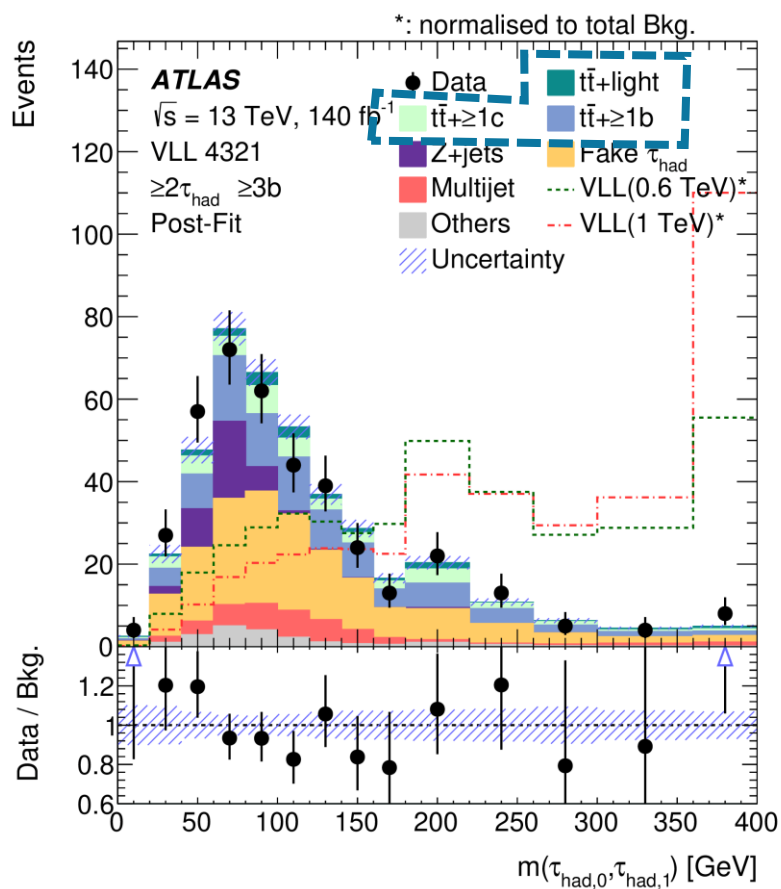

2503.22581

- The main background for both the  $\tau_{\text{had}}\tau_{\text{had}}$  and  $\tau_{\text{lep}}\tau_{\text{had}}$  channels comes from  $t\bar{t}$  events containing both real and fake taus.
- MC needs a standard kinematic reweighting to account for higher-order corrections (NNLO QCD + NLO EW).
- The high b-jet multiplicity region means that the  $t\bar{t}$  events come with extra heavy-flavor jets, which need to be modeled well.
  - This and other possible correction can be done in light-leptons regions like  $e\mu\text{OS}$ .

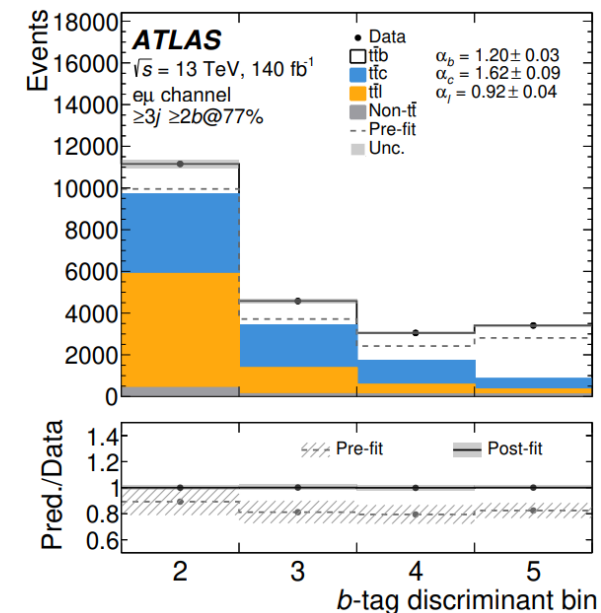
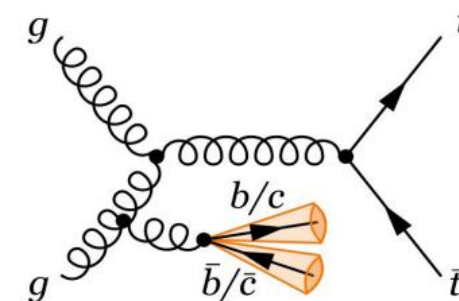

JHEP01(2025)068

# Estimating the background: $t\bar{t}$

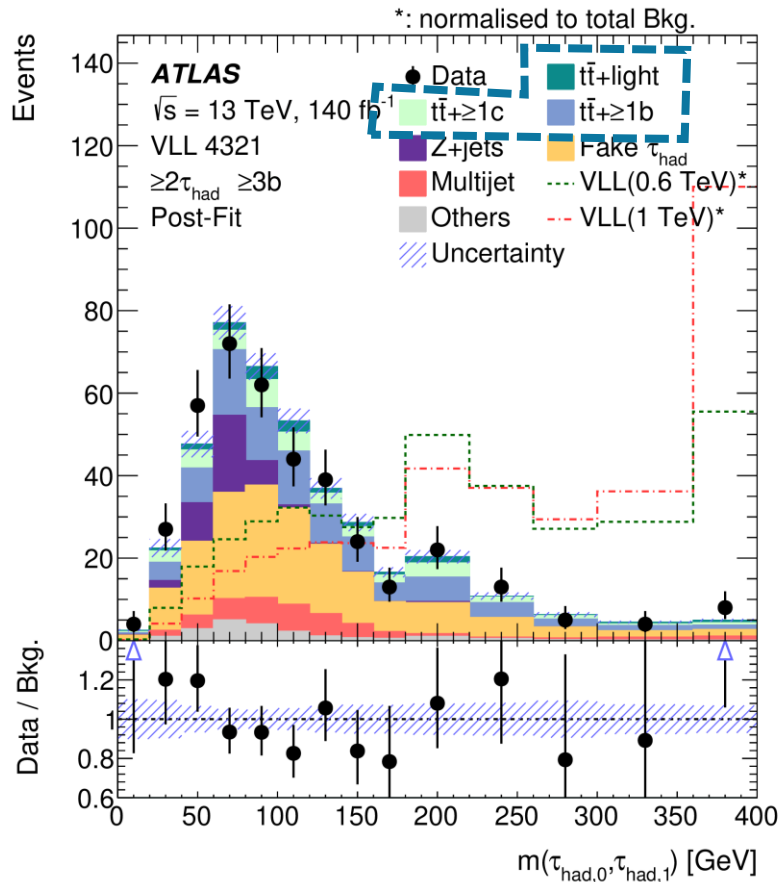

- The main background for both the  $\tau_{had}\tau_{had}$  and  $\tau_{lep}\tau_{had}$  channels comes from  $t\bar{t}$  events containing both real and fake taus.
  - We should make sure we have a good modeling across many variables of interest.

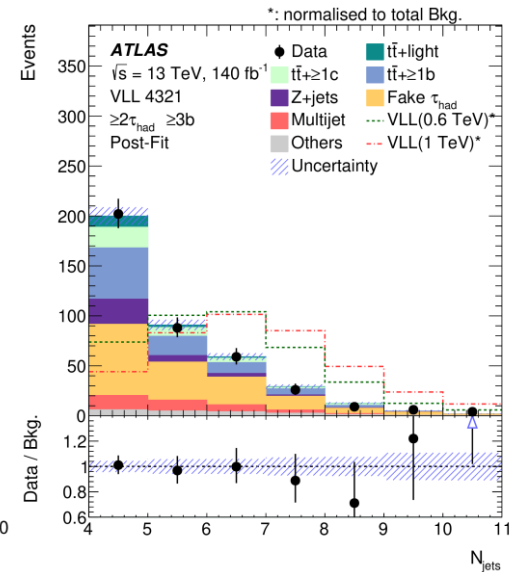
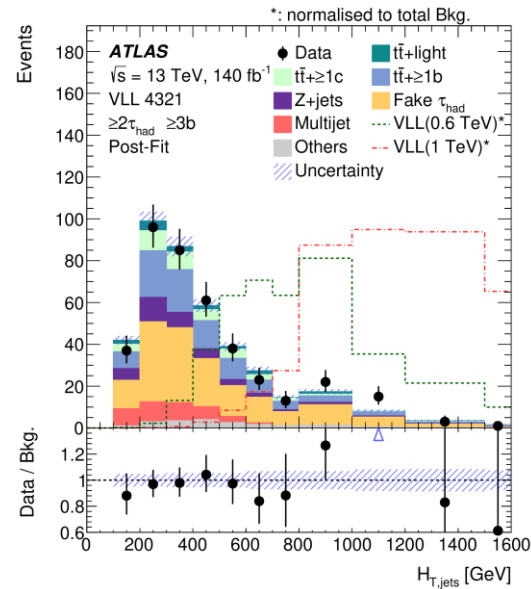
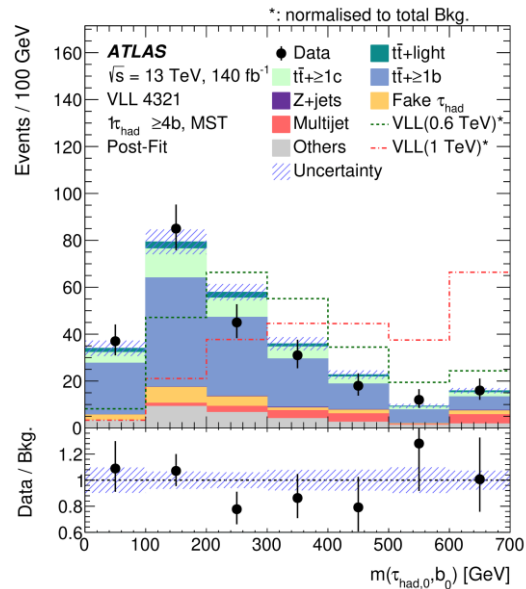

2503.22581

# Estimating the background: Z+jets

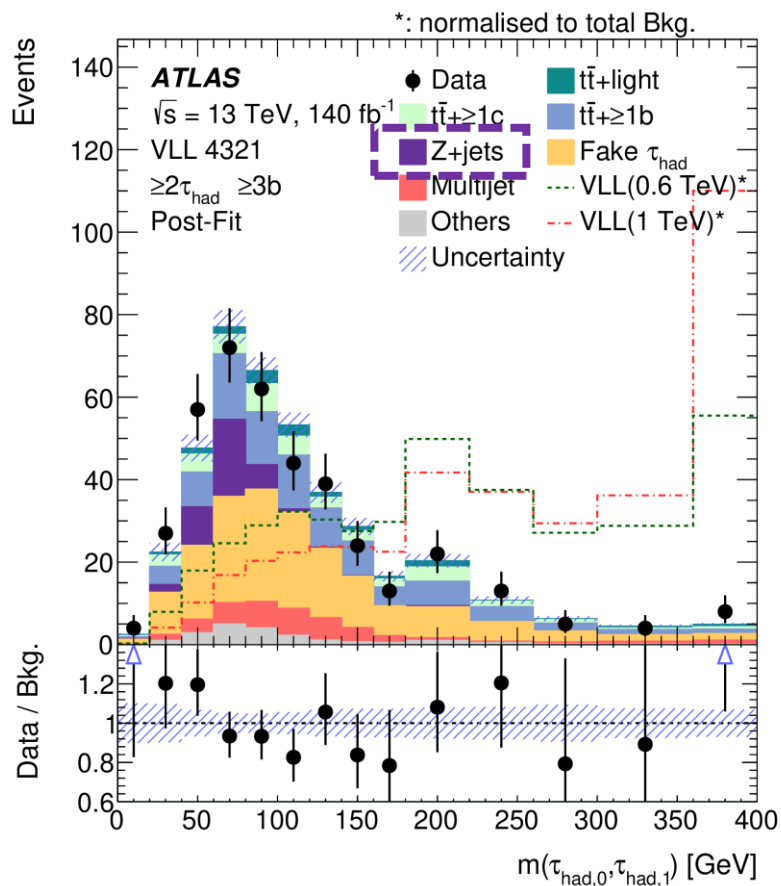

2503.22581

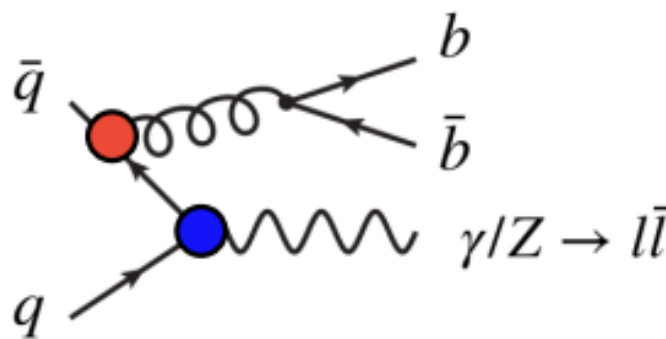

- $Z \rightarrow \tau_{\text{had}} \tau_{\text{had}}$  with extra heavy-flavor jets also has a sizeable contribution to the background in the  $\tau_{\text{had}} \tau_{\text{had}}$  channel.
- The modeling of the production of extra heavy-flavor jets in the Monte Carlo needs to be investigated carefully.
  - This and other possible correction can be done in light-leptons regions like  $eeOS$  and  $\mu\mu OS$ .

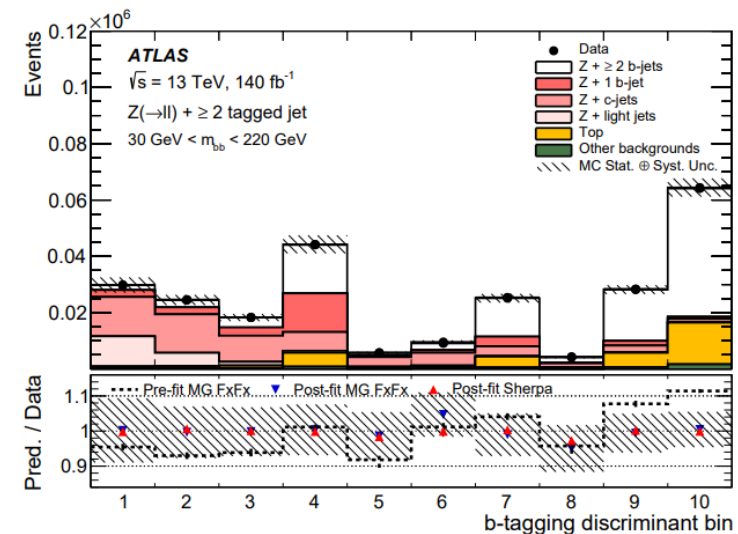

2403.15093

# Estimating the background: non-Multijet Fake $\tau_{had}$

- The fake  $\tau_{had}$  background is mostly composed by semi-leptonic  $t\bar{t}$ .
- Large presence in both the  $\tau_{had}\tau_{had}$  and  $\tau_{lep}\tau_{had}$  channels.
- Fake  $\tau_{had}$  not well modeled out of the box by MC simulations.

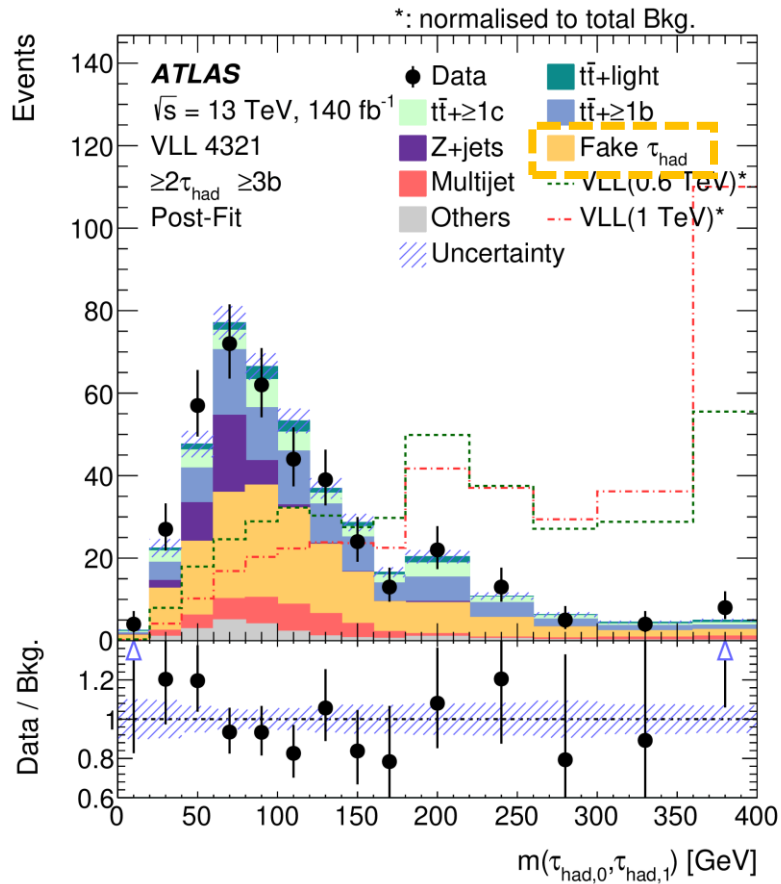

2503.22581

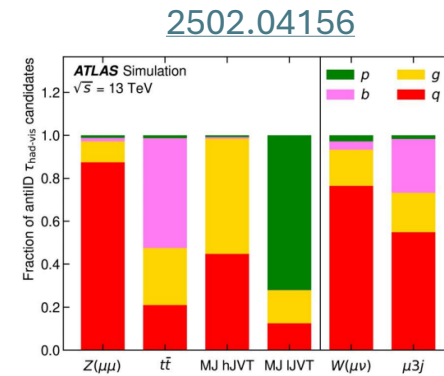
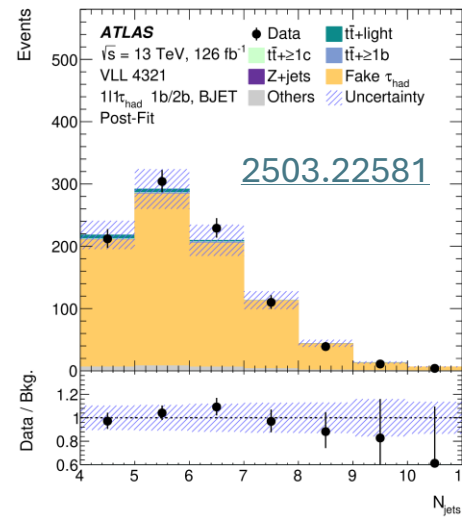

- Corrections are usually needed for this bkg. We can go to  $\tau_{had}\tau_{lep}SS$  for that.
- Useful to correct according to the fake  $\tau_{had}$  origin: LF-jets, b-quarks, gluon, others...

# Estimating the background: non-Multijet Fake $\tau_{had}$

- The fake  $\tau_{had}$  background is mostly composed by semi-leptonic  $t\bar{t}$ .
- Large presence in both the  $\tau_{had}\tau_{had}$  and  $\tau_{lep}\tau_{had}$  channels.
- Fake  $\tau_{had}$  not well modeled out of the box by MC simulations.

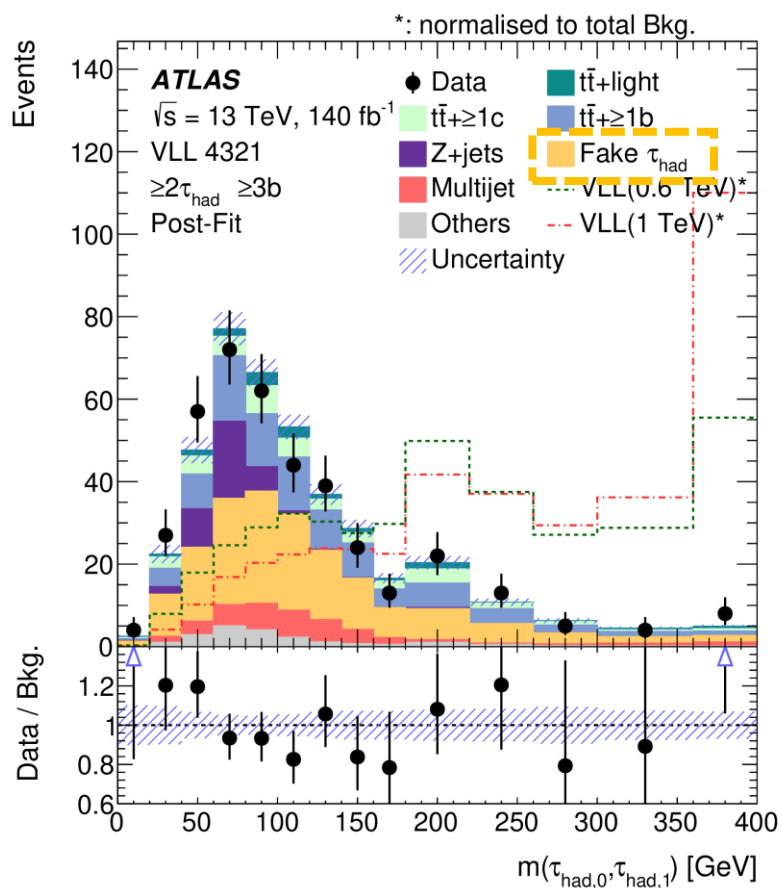

2503.22581

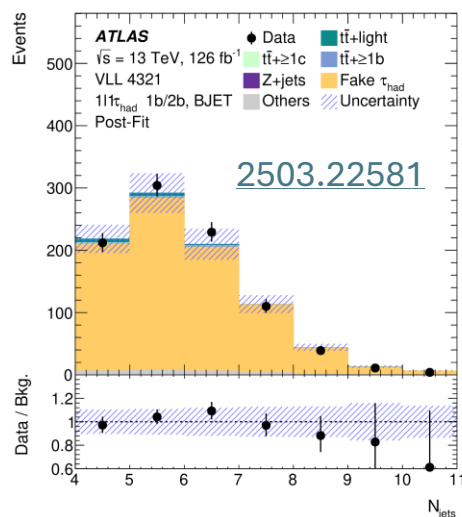

2503.22581

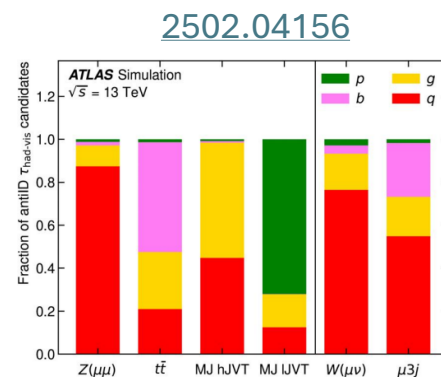

- Corrections are usually needed for this bkg. We can go to  $\tau_{had}\tau_{lep}SS$  for that.
- Useful to correct according to the fake  $\tau_{had}$  origin: LF-jets, b-quarks, gluon, others...

- A useful way to separate and control backgrounds with real and fake taus is to define a variable based on the tau identification.
- Also allows using taus with loose ID.

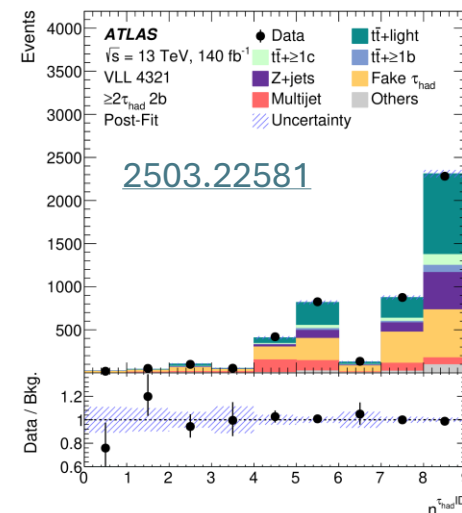

# Estimating the background: QCD Multijet

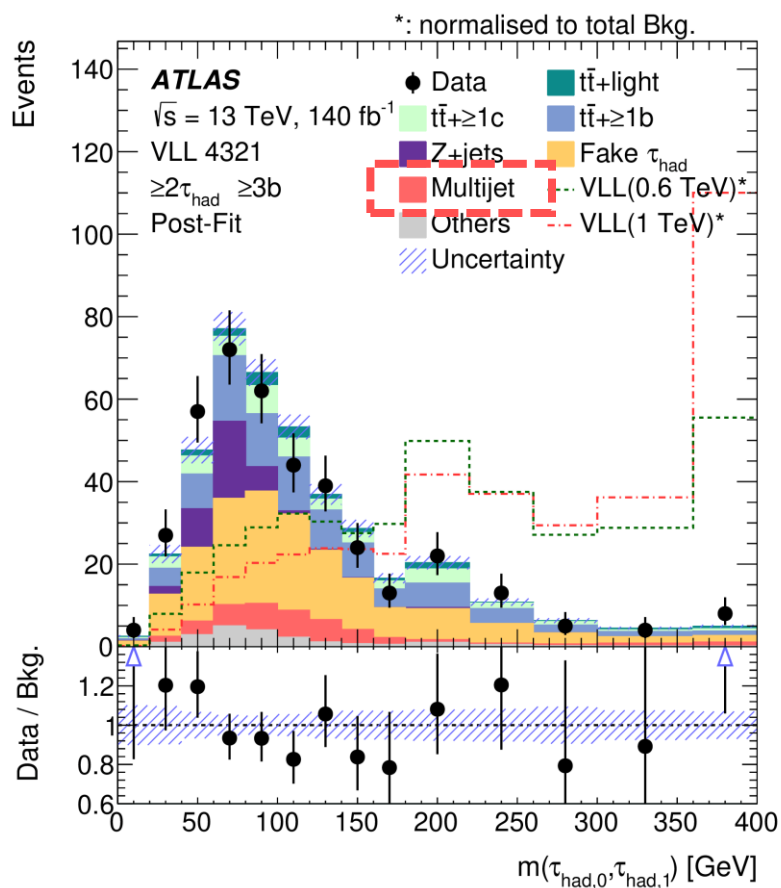

2503.22581

- The other part of the fake hadronic tau background is composed by QCD multijet background events.
- Not well simulated in MC, we need to use data-driven estimation methods.
- The high b-jet multiplicity region is depleted in statistics, a way to go around that is using the anti-tau-ID region for this estimation.
  - Fake factor method.
- \* not much of a worry in the  $\tau_{\text{had}}\tau_{\text{lep}}$  channel

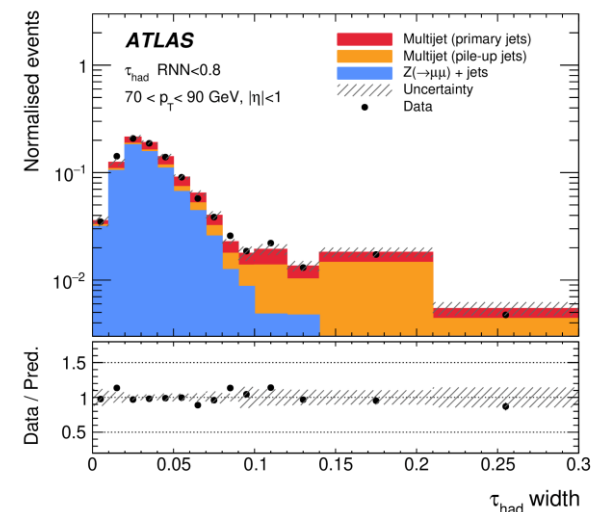
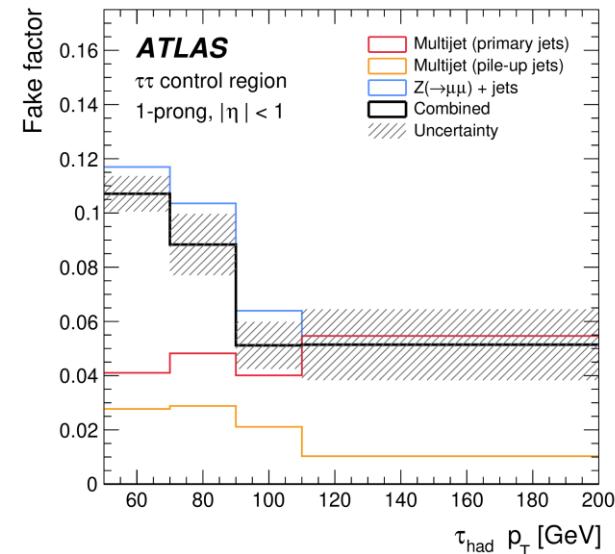

2503.19836



# Rounding up an analysis strategy

- Signal regions for  $\tau_{had}\tau_{had}$  and  $\tau_{lep}\tau_{had}$  decay channels with  $\geq 3b$  (split into 3b and 4b).
- Neural Network Score as final discriminant in the statistical fit to data.

VLL signal regions (minus 1tau channel)

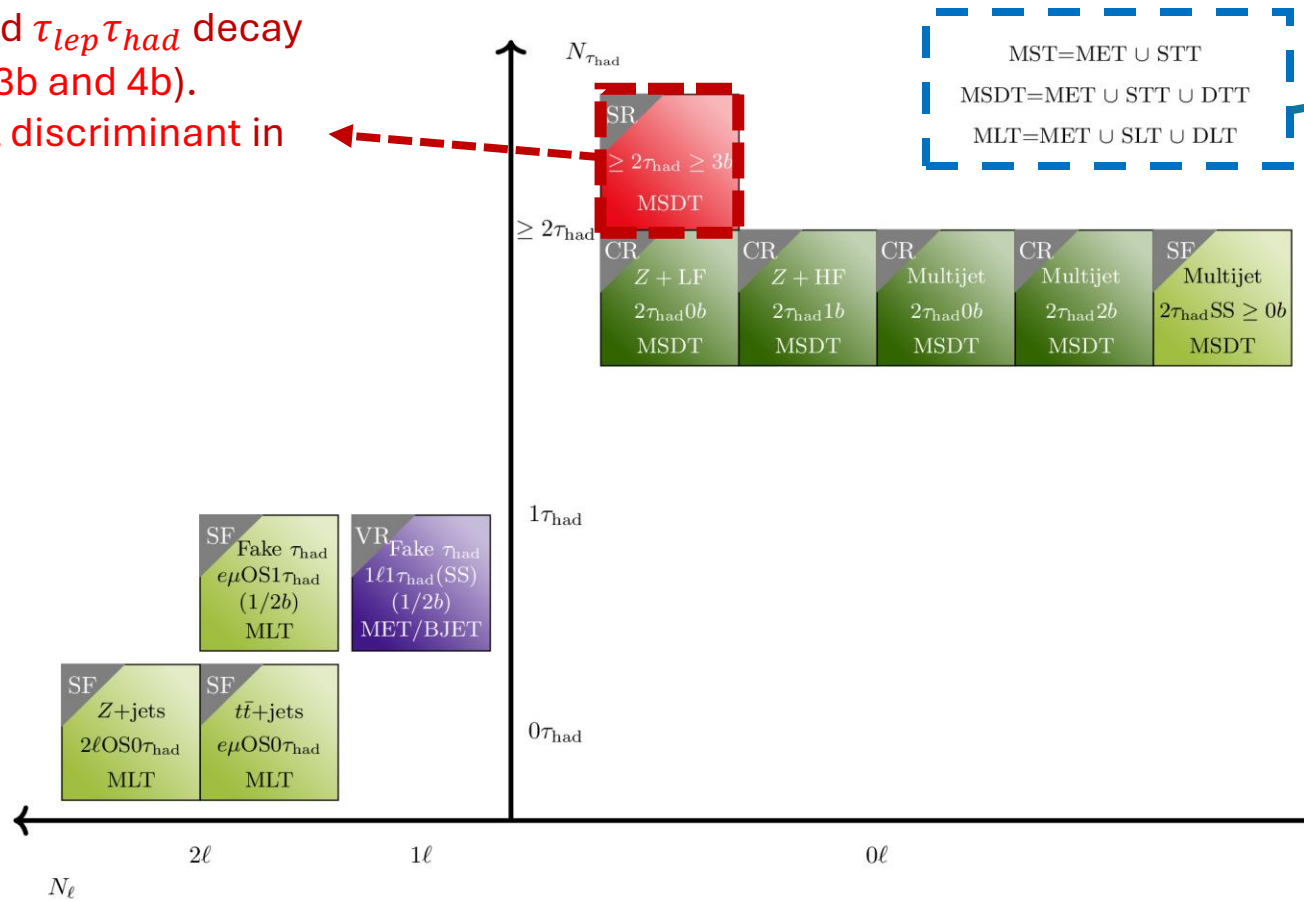

- Include all possible interesting triggers in a bucket strategy: single-tau, di-tau, and b-jet triggers mainly. Plus, a possible b+ $\tau$  trigger for 2024.

# Rounding up an analysis strategy

VLL signal regions (minus 1tau channel)

- Signal regions for  $\tau_{had}\tau_{had}$  and  $\tau_{lep}\tau_{had}$  decay channels with  $\geq 3b$  (split into 3b and 4b).
- Neural Network Score as final discriminant in the statistical fit to data.

- Fake tau background modeling can be improved using the 1l1 $\tau$ SS region.
- Z+jets corrections could be derived from the 2lSFOS region.
- Good  $t\bar{t}$  modeling is fundamental, corrections should be derived from the  $e\mu$ OS channel.

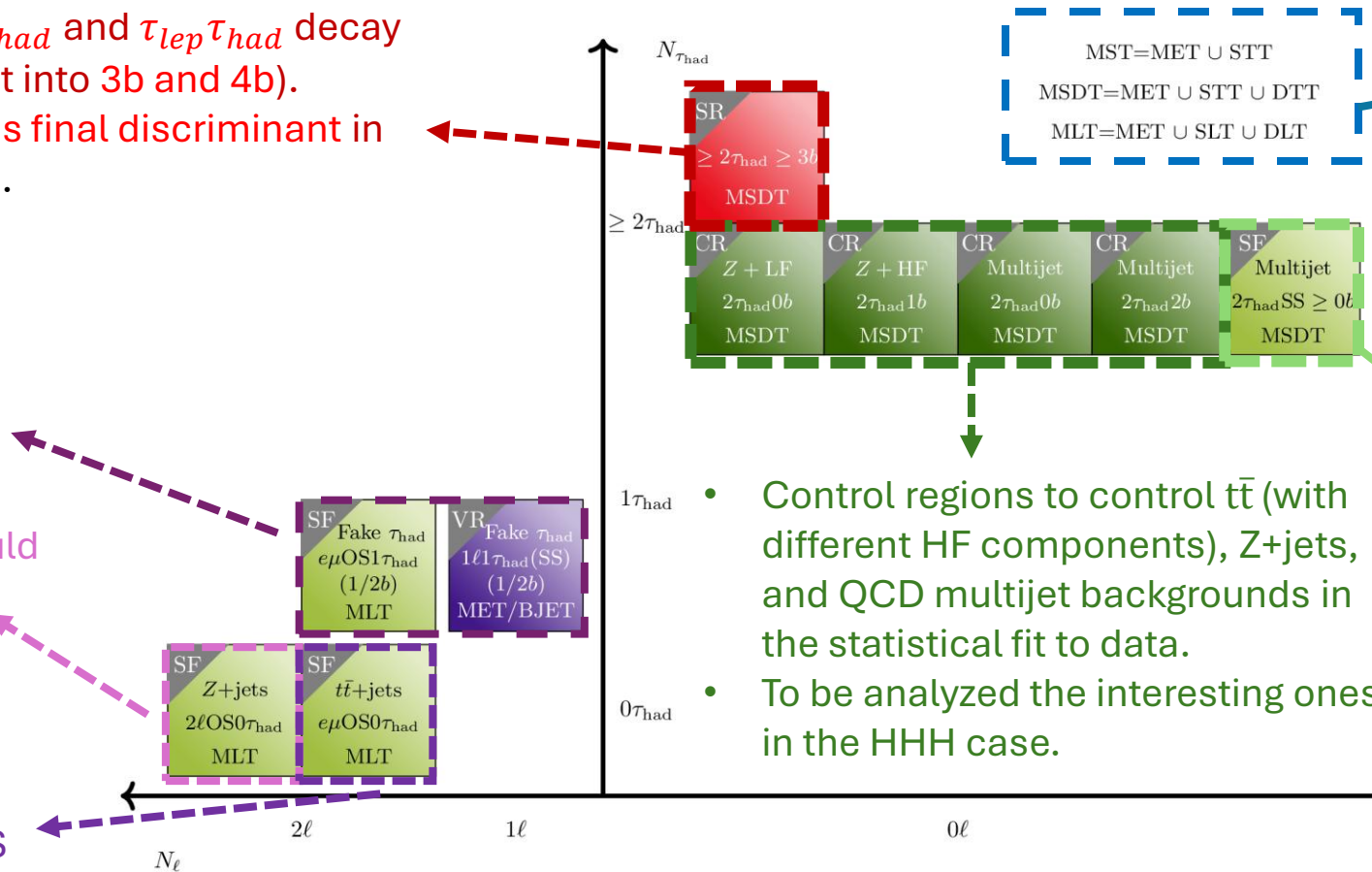

- Include all possible interesting triggers in a bucket strategy: single-tau, di-tau, and b-jet triggers mainly. Plus, a possible b+ $\tau$  trigger for 2024.

- Control regions to control  $t\bar{t}$  (with different HF components), Z+jets, and QCD multijet backgrounds in the statistical fit to data.
- To be analyzed the interesting ones in the HHH case.

- Good estimation of the QCD multijet background. Should use a template that has good statistics (make use of the anti-ID taus instead of  $2\tau_{had}SS$ ).



Thank you :)

---

# VLL4321

- This analysis searches for vector-like leptons (VLLs) in the context of the 4321 model.
  - VLLs are hypothetical particles whose left- and right-handed chiral components have the same transformation properties under the SU(2) gauge group.
- The 4321 model is UV-complete and extends the SM with a new symmetry group:
 
$$SU(4) \times SU(3)' \times SU(2)_L \times U(1)'$$
- The new particles predicted:
  - 3 heavy gauge bosons: Color octet ( $g'$ ), Vector LQ ( $U_\mu$ ), Color singlet ( $Z'$ )
  - VLQ doublets:  $U/D$ ,  $C/S$ ,  $T/B$
  - VLL doublets:  $N_1/E_1$ ,  $N_2/E_2$ ,  $N_3/E_3$
- VLLs favors decays via vector LQ  $U_1$  into third generation quarks and leptons.
- Offers a signature with multiple taus, b-jets, jets, leptons and MET.

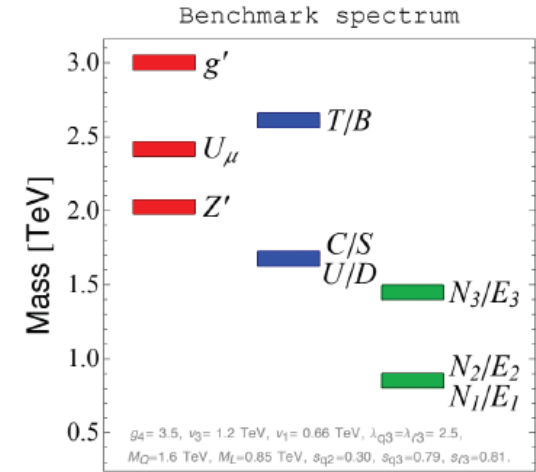

[1808.00942](#)

\* We consider a simplified model: one VLL family and neglecting contributions from the  $Z'$ -mediated processes.

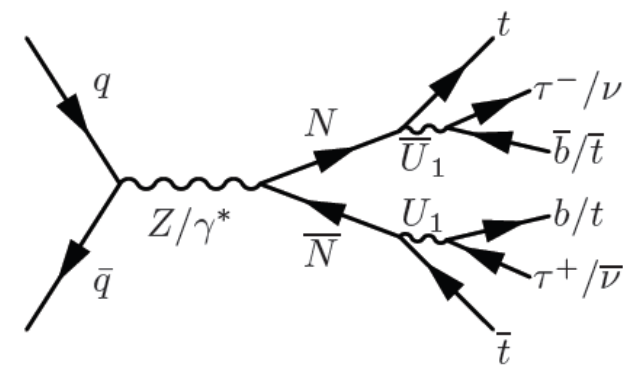
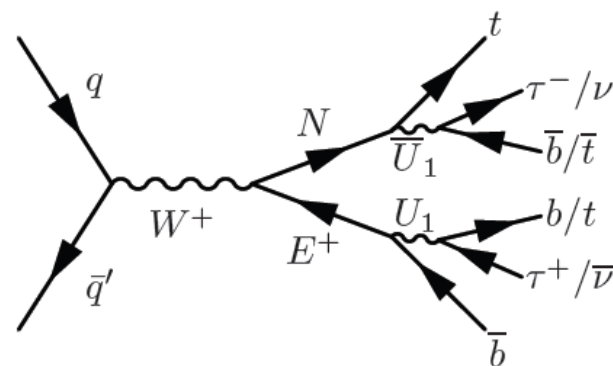
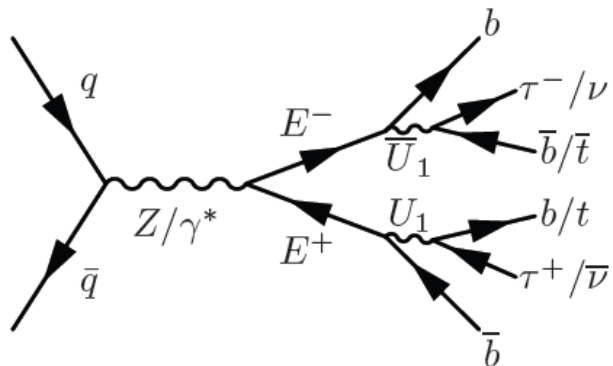

# HH and HHH BRs

	bb	WW	ττ	ZZ	ΥΥ
bb	34%				
WW	25%	4.6%			
ττ	7.3%	2.7%	0.39%		
ZZ	3.1%	1.1%	0.33%	0.069%	
ΥΥ	0.26%	0.10%	0.028%	0.012%	0.0005%

	bb	WW	ττ	ZZ	ΥΥ
bbbb	18.4%				
bbWW	20.7%	8.2%			
bbττ	6.1%	4.7%	0.7%		
bbZZ	2.7%	2.0%	0.6%	0.1%	
bbΥΥ	0.2%	0.2%	0.05%	0.02%	0.0009%

# HHH feynman diagrams

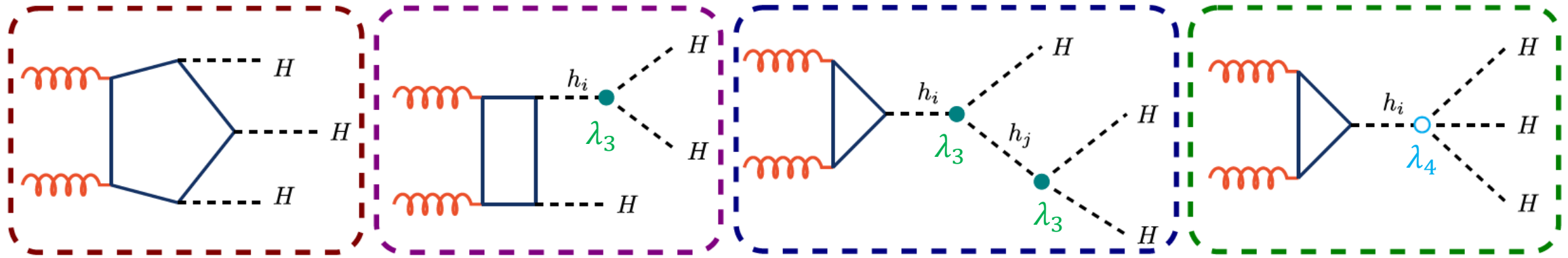

[2411.02040](#)