

CMS Tau identification in the context of $HHH \rightarrow 4b2\tau$



Dennis Roy on behalf of the CMS collaboration

29th September 2025

Introduction

- Production cross section of HHH events is low
 - To study, need to look for final states with high branching fraction
- $H \rightarrow b\bar{b}$ has the highest branching ratio
 - But, major QCD background, and combinatorics may be difficult
- Considering Taus instead will lower the BR, but gives a cleaner final state
 - $BR(HHH \rightarrow b\bar{b} + b\bar{b} + \tau\tau) = 6.371\%$
 - Major background from $T\bar{T}$

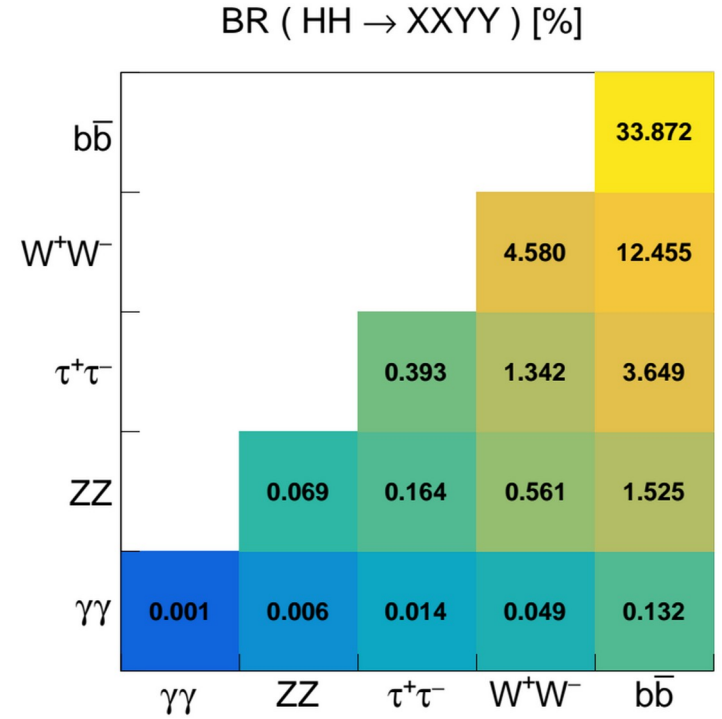

Multiply values with 0.582 and add combinatorial factors to get BR ($HHH \rightarrow b\bar{b} + XXYY$)

- Taus can decay leptonically or hadronically:
 - Decays into Muons or Electrons are simple: Just look for those leptons
 - Products of hadronic Tau decay are charged and neutral pions
 - Hadronically decaying Taus are identified by their “decay mode” (DM), that is, how many charged and neutral pions it decays into
- Analysis on $HHH \rightarrow 4b2\tau$ can be categorized by final state of $\tau\tau$ system

Branching fraction of single Tau

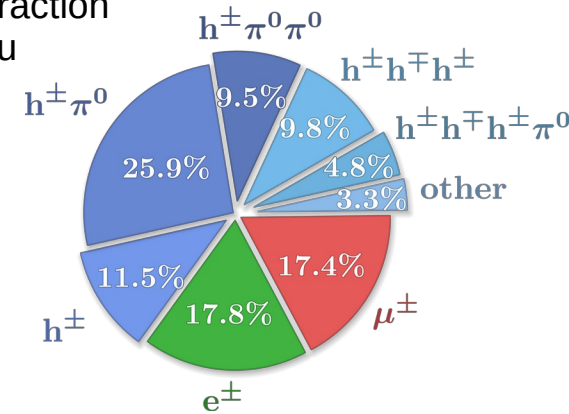

Branching fraction of $\tau\tau$ system

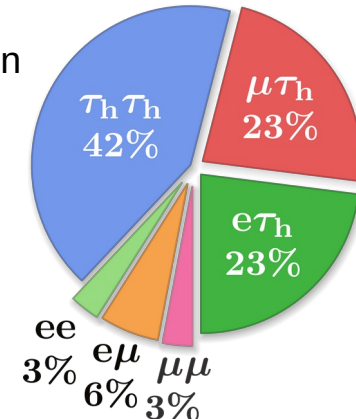

- Reconstruction of hadronically decaying Taus (or just “Taus” in the following) is done with the Hadrons-Plus-Strips (HPS) algorithm
 - Tau candidates are seeded from anti-kT jets with cone size $\Delta R=0.4$ (“AK4 jets”)
 - Charged hadrons selected from charged tracks in smaller cone
 - “Strips” are neutral pion candidates obtained from electron/photon constituents in ECAL strips over $\Delta\phi$ - $\Delta\eta$ within the jet
- p_T , mass and decay mode of the Tau is determined from only these hadrons identified by HPS

More information on HPS:

- [CMS-TAU-16-003](#)
- [CMS-TAU-20-001](#)

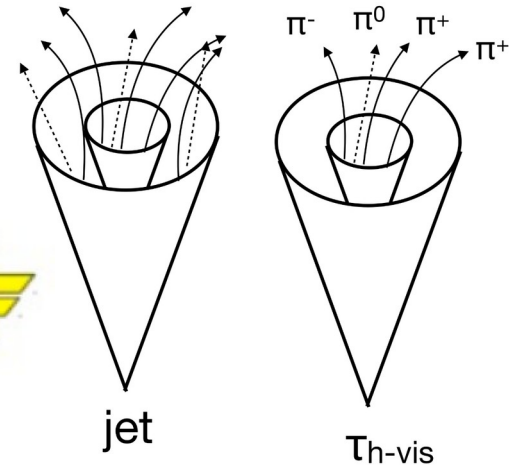
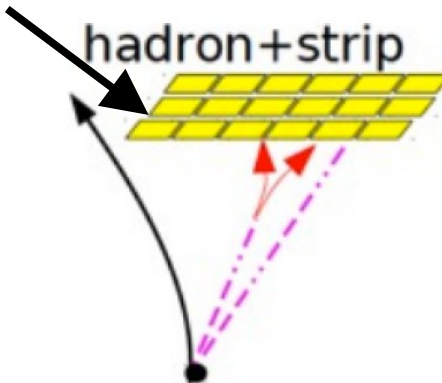

- Taus must be well identified, and separated from jets, electrons and muons
- Various identification algorithms are available in CMS analyses:
 - DeepTau
 - ParticleNet
 - Unified Particle Transformer / Unified Jet Tagger

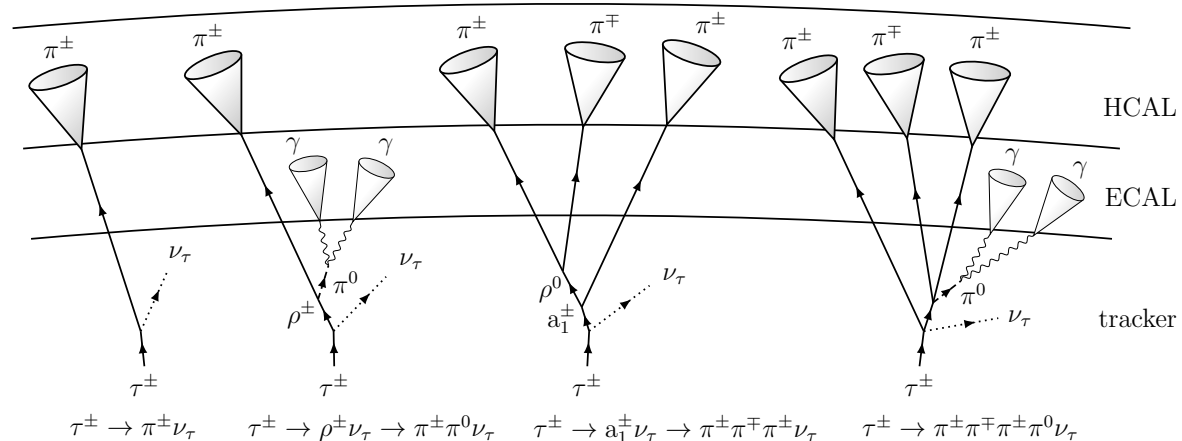

DeepTau

- DeepTau is a deep convolutional neural network based Tau ID algorithm, superseding previously used MVA algorithms
- DeepTau v2.1 initially recommended ID for Run2 analyses
- DeepTau v2.5 contains various improvements:
 - Domain adaptation by backpropagation (training on data too instead of simulation only)
 - Larger and more balanced training dataset
 - Optimized hyperparameters
- Network output is 4 variables, how likely the object is a genuine Tau or fake Jet/Muon/Electron
- Used to construct 3 discriminants:
 - Tau Vs Jet, Tau Vs Muon, Tau Vs Electron

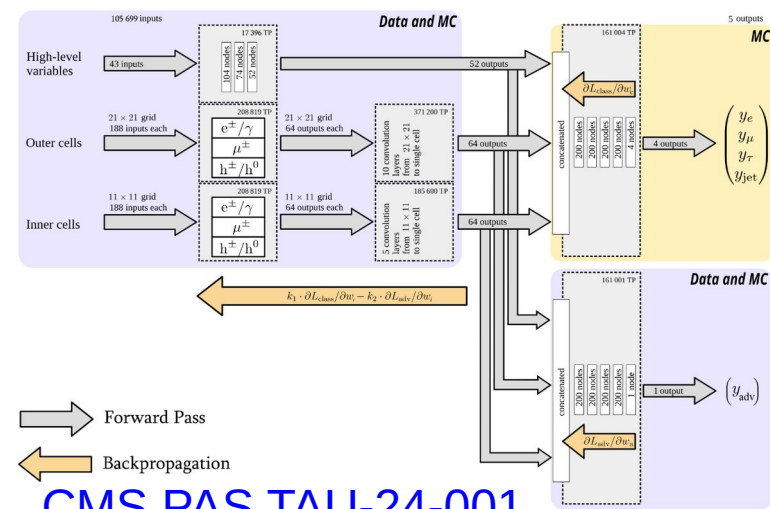
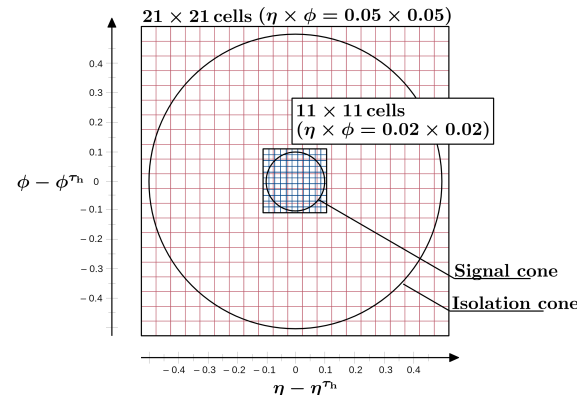

Taus are selected if they pass the required working points of all three discriminators

Improvement (from left to right) in Data/MC agreement after addition of domain adaptation

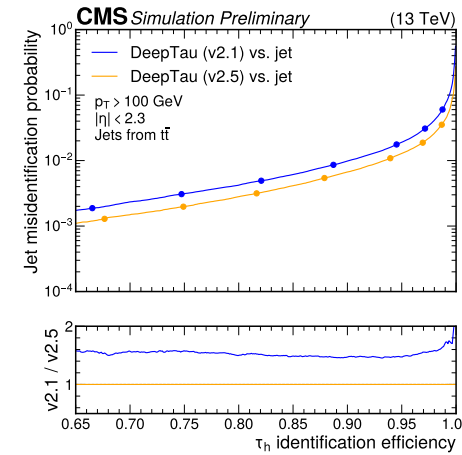
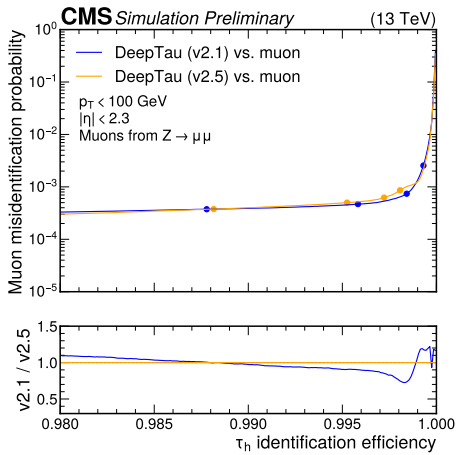
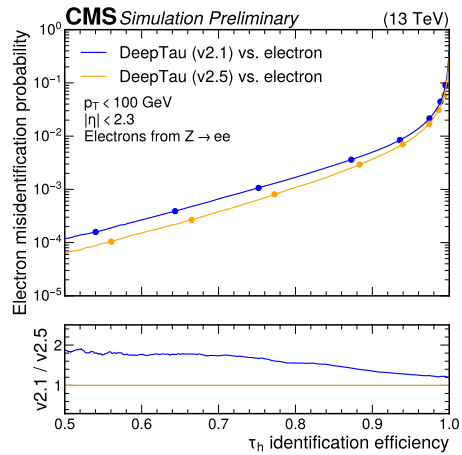
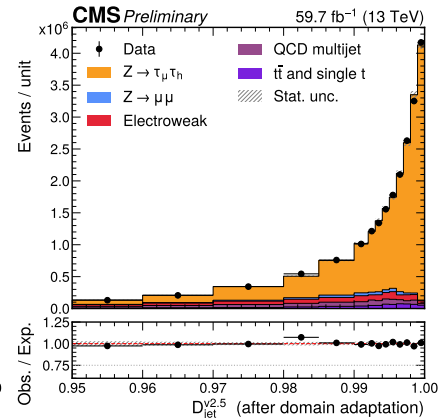
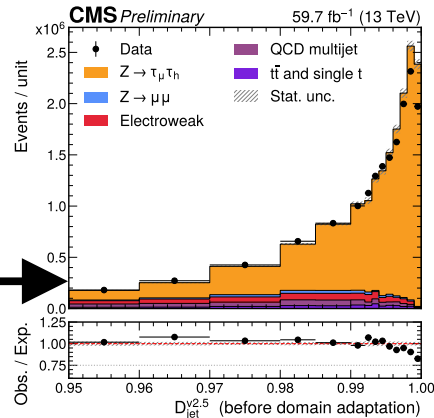

Improvement of Tau identification vs Electrons (left), Muons (middle), Jets (right) using DeepTau v2.5

- ParticleNet (“PNet”) is a Dynamic Graph Convolutional Neural Network that treats AK4 jets as “particle clouds”, using all available raw information to determine the particle of origin
 - Ref.: <https://arxiv.org/pdf/1902.08570>
- HPS is not involved, as PNet simply evaluates all Jets themselves, which means:
 - Some Taus may be recovered, if they are identified by PNet as Taus, but were not reconstructed by HPS
 - The decay mode of an identified Tau is that of the corresponding class with the highest score (there are 5 classes, for the 5 most common Tau decay modes)
 - The Tau p_T is a regressed p_T , also determined by PNet
- Same as DeepTau, discrimination of Taus against Jets/Muons/Electrons is provided

- The Unified Jet Tagger (“UParT”) is a ParticleTransformer model, which considers jets as particle clouds, same as PNet, but also includes adversarial training for improved resistance against mismodeling effects in simulated events

- Ref.: <https://arxiv.org/pdf/2202.03772>

- The same kinds of outputs are provided by UParT as PNet:

- Decay mode by classification
- Regressed Tau p_T
- Discrimination against Jets/Muons/Electrons

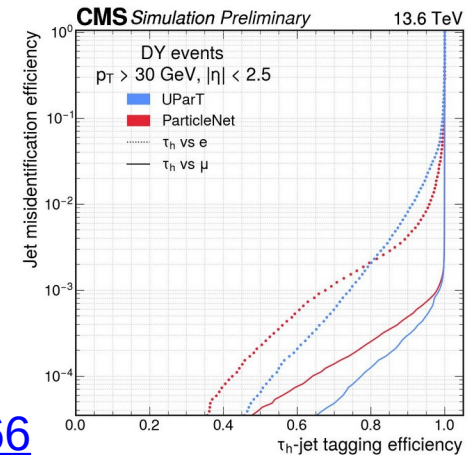
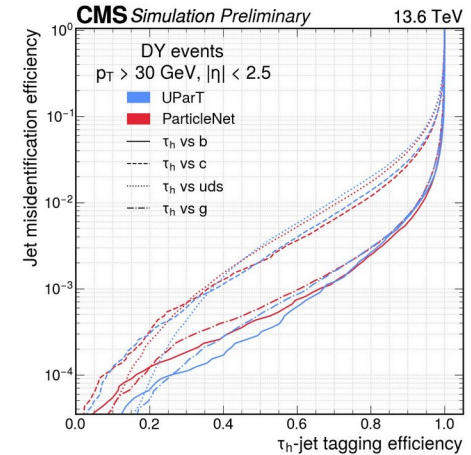

- DeepTau is so far still the recommended ID in CMS, and scale factors for v2.5 are available for Run2 and Run3
 - Best available ID for rejection of Taus misidentified from Electrons/Muons
- PNet is a valid alternative, especially since it's already used for b-jet identification in HHH \rightarrow 6b (and will be in HHH \rightarrow 4b2 τ)
 - Recovers additional Taus not reconstructed by HPS algorithm
 - Better performance for rejection against Jets by 10-15% than DeepTau
- UParT is very similar to PNet in terms of performance
 - Because of this, CMS TauPOG will only support either PNet or UParT
 - UParT is still very new, so studies about this are still ongoing

Tau ID in HHH \rightarrow 4b2 τ

- In SM $H \rightarrow \tau\tau$ analysis, $\tau_h\tau_h$ final state dominated by background with Jets misidentified as Taus
 - Larger benefit from PNet/UParT
- $\mu\tau_h$, and especially $e\tau_h$ final state, have larger contribution of Taus misidentified from leptons, from $Z \rightarrow \mu\mu/ee$
- But, in $HHH \rightarrow 4b2\tau$, $T\bar{T}$ is dominant background in $\mu\tau_h/e\tau_h$, and both final states could have the Tau be a misidentified Electron from one of the W boson decay
 - Study required, whether DeepTau or PNet/UParT are more efficient in $\mu\tau_h/e\tau_h$ final states of $HHH \rightarrow 4b2\tau$ analysis

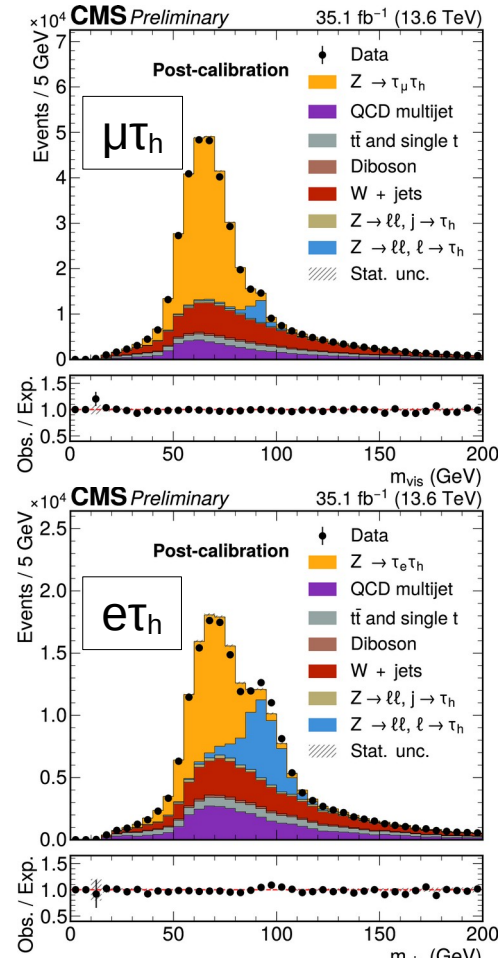

- Each Higgs boson's decay products can be either resolved or boosted
 - Resolved: Use 2 regular "AK4" Jets or 2 Taus to reconstruct a Higgs boson
 - Boosted: Use a single large-cone "AK8" Jet as the Higgs boson candidate, or 2 "BoostedTau" objects
 - BoostedTau objects are seeded from the subjets of "CA8" Jets (reconstructed using Cambridge-Aachen clustering and $\Delta R=0.8$ cone size)

- More discriminators exist to identify a boosted Higgs boson decaying into Taus:

- Boosted DeepTau
- ParticleNetAK8
- Global Particle Transformer
 - Very new, not discussed here

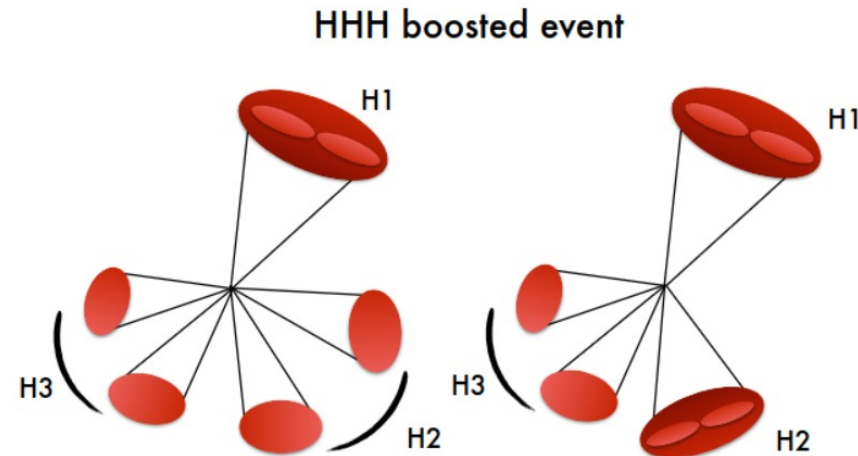

Boosted DeepTau

- The network structure for the Boosted DeepTau algorithm is identical to that of DeepTau v2.5 (with the exception of excluded domain adaptation)
- Improvement by more than factor 10 in discrimination of high p_T Taus in boosted systems against jets, compared to previously available boosted MVA Iso discriminator
- Reconstruction of boosted Taus from CA8 Jets, alongside identification by Boosted DeepTau, yields much higher selection efficiency than when attempting to reconstruct two “regular” Taus with DeepTau v2.5
 - Especially in more boosted systems

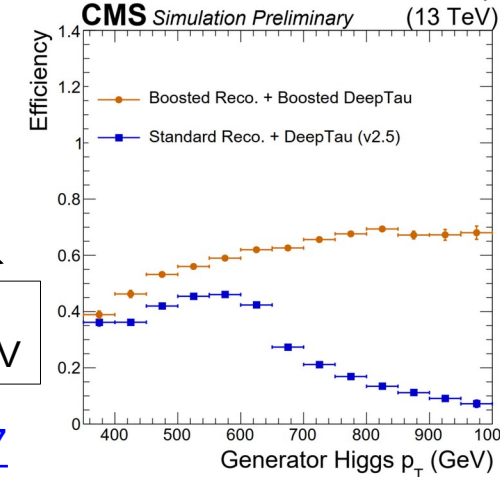
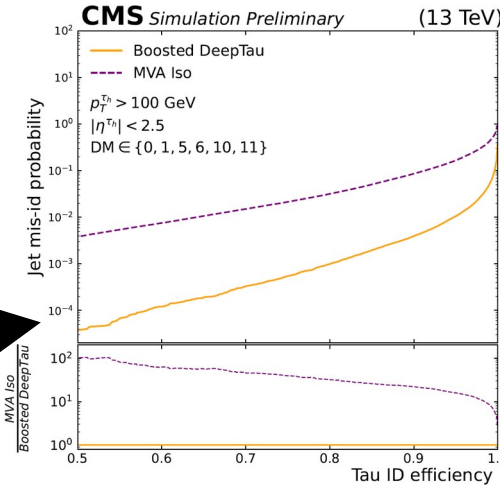

Events from $X \rightarrow HH \rightarrow bb\tau\tau$
 with $\tau\tau \rightarrow \tau_h\tau_h$ and $m_X = 3.5$ TeV

- Separate ParticleNet trained on AK8 Jets
 - It is mass-decorrelated, by training the network on objects with flat distribution over p_T and mass
- Besides the discriminant for $X \rightarrow bb / cc / gg$ and light jets against QCD background, there are three separate discriminant for the $\tau_h\tau_h$, $\mu\tau_h$ and $e\tau_h$ final states
 - Could be used directly for the respective categories
- PNet also provides a regressed mass for the AK8 Jets, which more accurately reconstructs the mass of the Jet

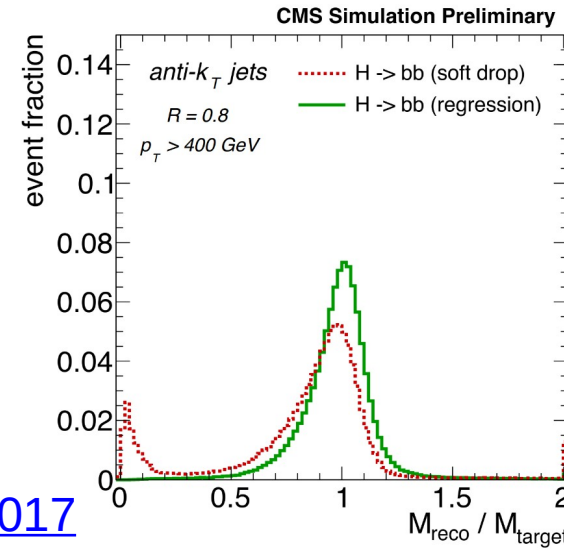
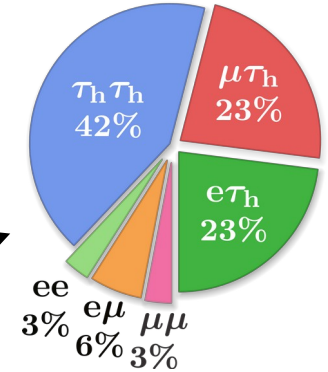

- Both the Boosted DeepTau and ParticleNet AK8 taggers are valid options
 - The “FastMTT” algorithm, an update on the previously known “SVfit” algorithm [1], is commonly used in various CMS SM $H \rightarrow \tau\tau$ analyses to obtain the invariant Higgs boson mass, including neutrino contributions
 - The algorithm requires two visible Tau decay products as input, so it would not be usable for single AK8 Jets selected with ParticleNet
 - ParticleNet is already used in the HHH \rightarrow 6b analysis, and would certainly be used in HHH \rightarrow 4b2 τ for identification of boosted $H \rightarrow b\bar{b}$, so using it was well for $H \rightarrow \tau\tau$ would make things nice and consistent
 - Availability of separate tagger for $\tau_h\tau_h/\mu\tau_h/e\tau_h$ final states is a neat feature
 - AK8 Jets also have other properties such as N-subjettiness, which could be used to further improve signal sensitivity / background rejection
- \rightarrow Detailed study required to determine which ID is better for the analysis

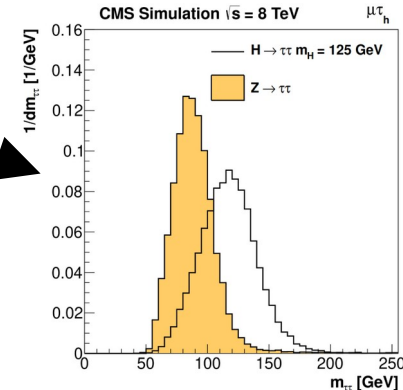

- Starting with Run3 in 2022, Tau triggers include requirement to pass identification by DeepTau
 - From 2024, Tau triggers include identification from PNet instead
- These are slimmed down versions of DeepTau/PNet used in online HLT, so there should be no loss in Tau identification efficiency by using the other discriminator in offline analysis instead of those used in these triggers
- New triggers are available since 2024, triggering on events with 4 Jets, out of which one is tagged as a jet originating from a b-quark, and one being a Tau, as identified by PNet
 - Useful for $HHH \rightarrow 4b2\tau$ and $HH \rightarrow 2b2\tau$ analyses

[CMS-DP-2023-024](#)

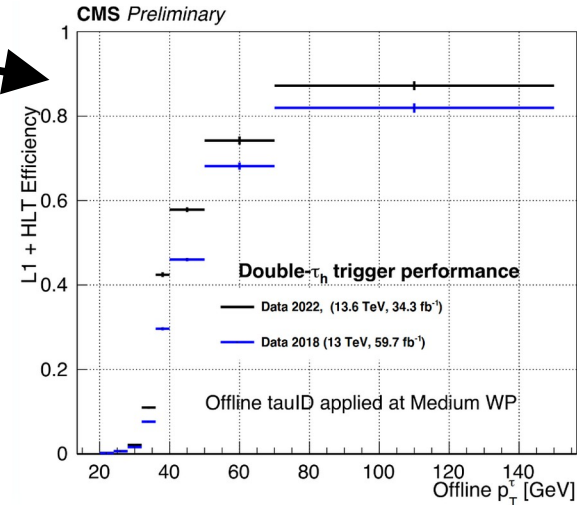

- Various new ML-based Tau identification algorithms exist
- For $HHH \rightarrow 4b2\tau$, should consider both resolved and boosted Taus
- Resolved: Having a lot of hadronic activity in selected events, we can benefit from PNet/UParT, but the background contribution from Taus misidentified from Electrons/Muons, which is better rejected with DeepTau, may not be negligible
 - If using PNet or UParT, it would make sense to use the same also for b-quark jet identification
- Boosted: There are strong arguments for using either DeepTau with Boosted-Tau objects or PNet with AK8 jets
 - Requires some studies, perhaps a one-to-one comparison to find which is more efficient, and a workaround on getting the invariant H boson mass without FastMTT if using AK8 jets

This work has been funded by the U.S. Department of Energy



**U.S. DEPARTMENT OF
ENERGY**