

Dortmund Celebration of Charm

Celebrating 50 years of
experimental charm physics

Johannes Albrecht, Jamie Gooding,
Dominik Mitzel, Donata Osthues, Luca Toscano
Fakultät Physik, TU Dortmund

7th March 2024, Session T 88.6

DPG Spring Meeting 2024, Karlsruhe

*D⁰*rtmund
celebration
of \bar{c} harm

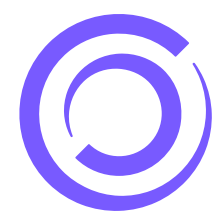

FSP LHCB
Erforschung von
Universum und Materie



Follow us: [@dortmund_lhcb](https://twitter.com/dortmund_lhcb)



What is charm?

- ▶ Charm is the second-heaviest *up-type quark* in the Standard Model (SM)
- ▶ Discovery in 1974 cemented much of the SM as we know it
 - Confirmation of *quark* model of hadronic physics
 - Paved way for discovery of electroweak unification
- ▶ Probe for BSM physics in the up-type sector
 - CKM elements, CP violating parameters
 - Null tests of heavily suppressed decays
 - Gateway between light and heavy flavour physics

C

Dortmund
celebration
of \bar{c} charm



Charming hypotheses

First proposed by Bjorken and Glashow

1964



Charming hypotheses

First proposed by Bjorken and Glashow ¹⁹⁶⁴

Glashow, Iliopoulos and Maiani then proposed "charmness"

⇒ GIM mechanism required 4th quark to unify
electromagnetic and weak forces

¹⁹⁷⁰



Dortmund
celebration
of charm

Charming hypotheses

First proposed by Bjorken and Glashow

1964

Glashow, Iliopoulos and Maiani then proposed "charmness"

⇒ GIM mechanism required 4th quark to unify electromagnetic and weak forces

1970

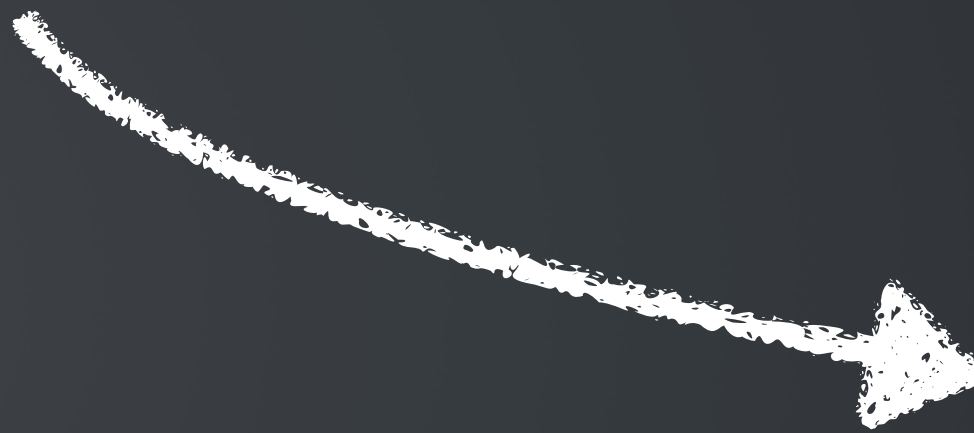

1979

Electroweak unification

Glashow, Salam and Weinberg

Charming hypotheses

First proposed by Bjorken and Glashow

1964

Glashow, Iliopoulos and Maiani then proposed "charmness"

⇒ GIM mechanism required 4th quark to unify electromagnetic and weak forces

1970

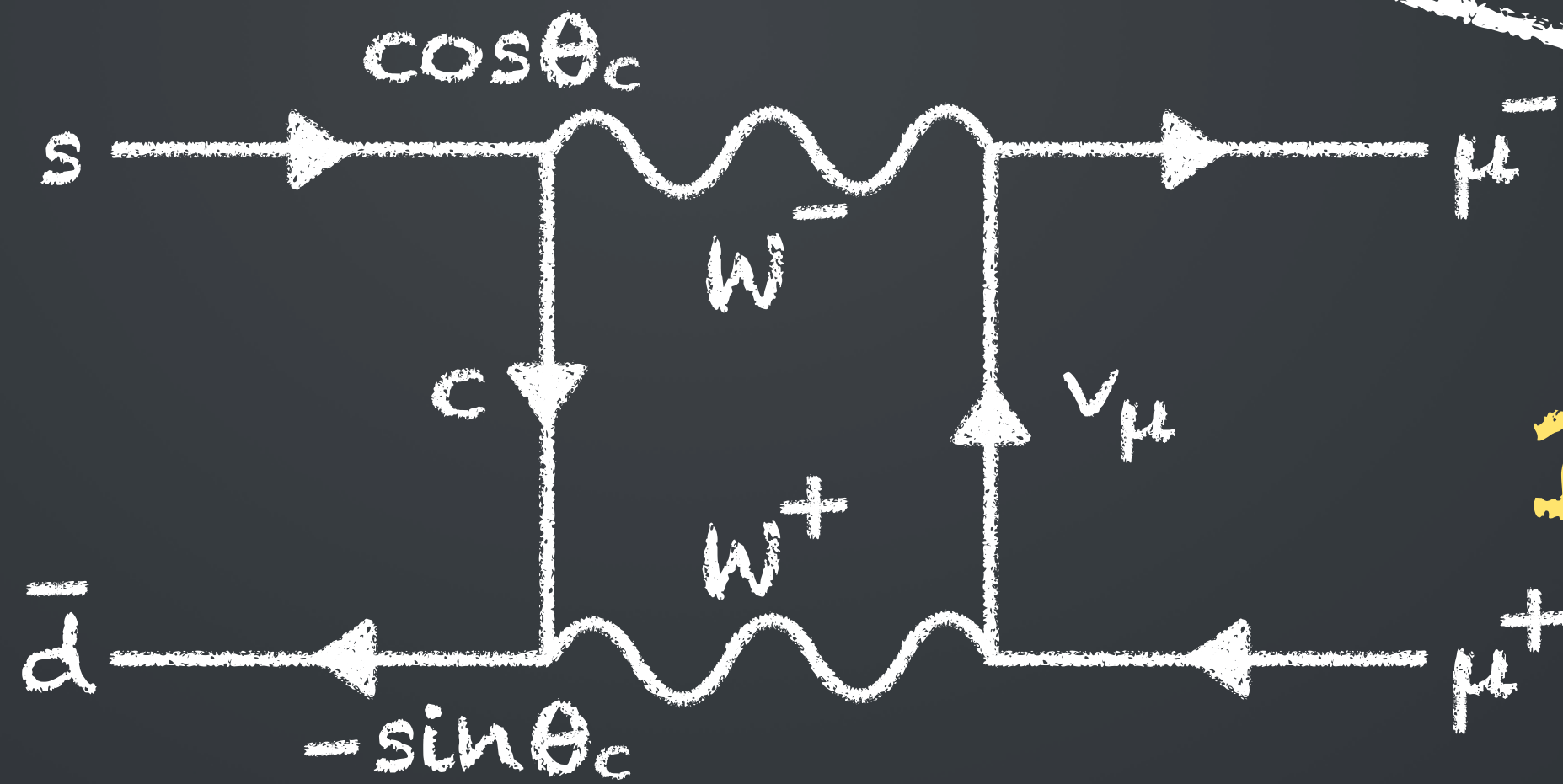
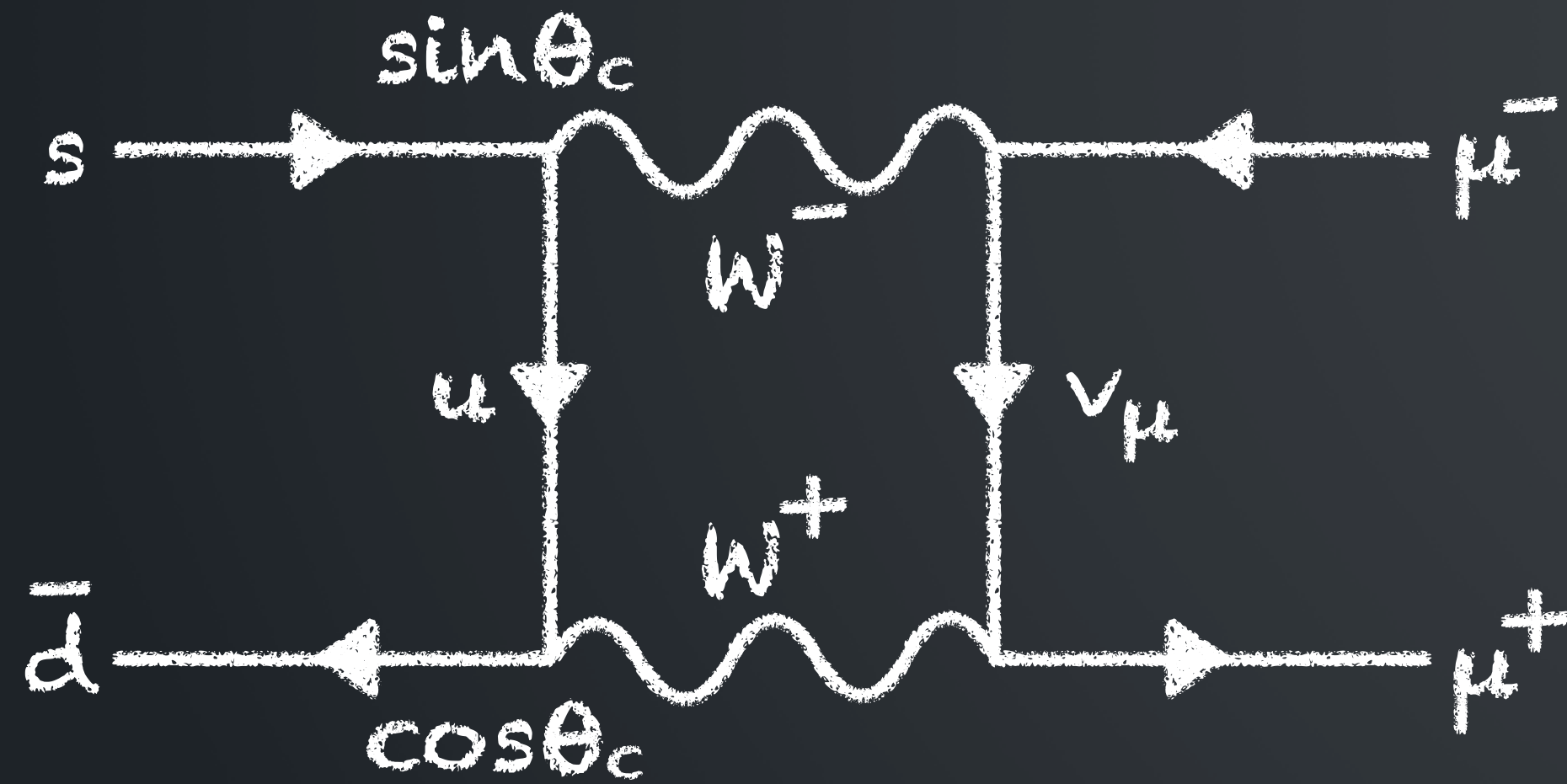

Suppression as $\sin\theta_c \cos\theta_c$ and $-\sin\theta_c \cos\theta_c$ terms cancel!



1979

Electroweak unification

Glashow, Salam and Weinberg

Charming hypotheses

First proposed by Bjorken and Glashow

1964

Glashow, Iliopoulos and Maiani then proposed "charmness"

⇒ GIM mechanism required 4th quark to unify electromagnetic and weak forces

1970

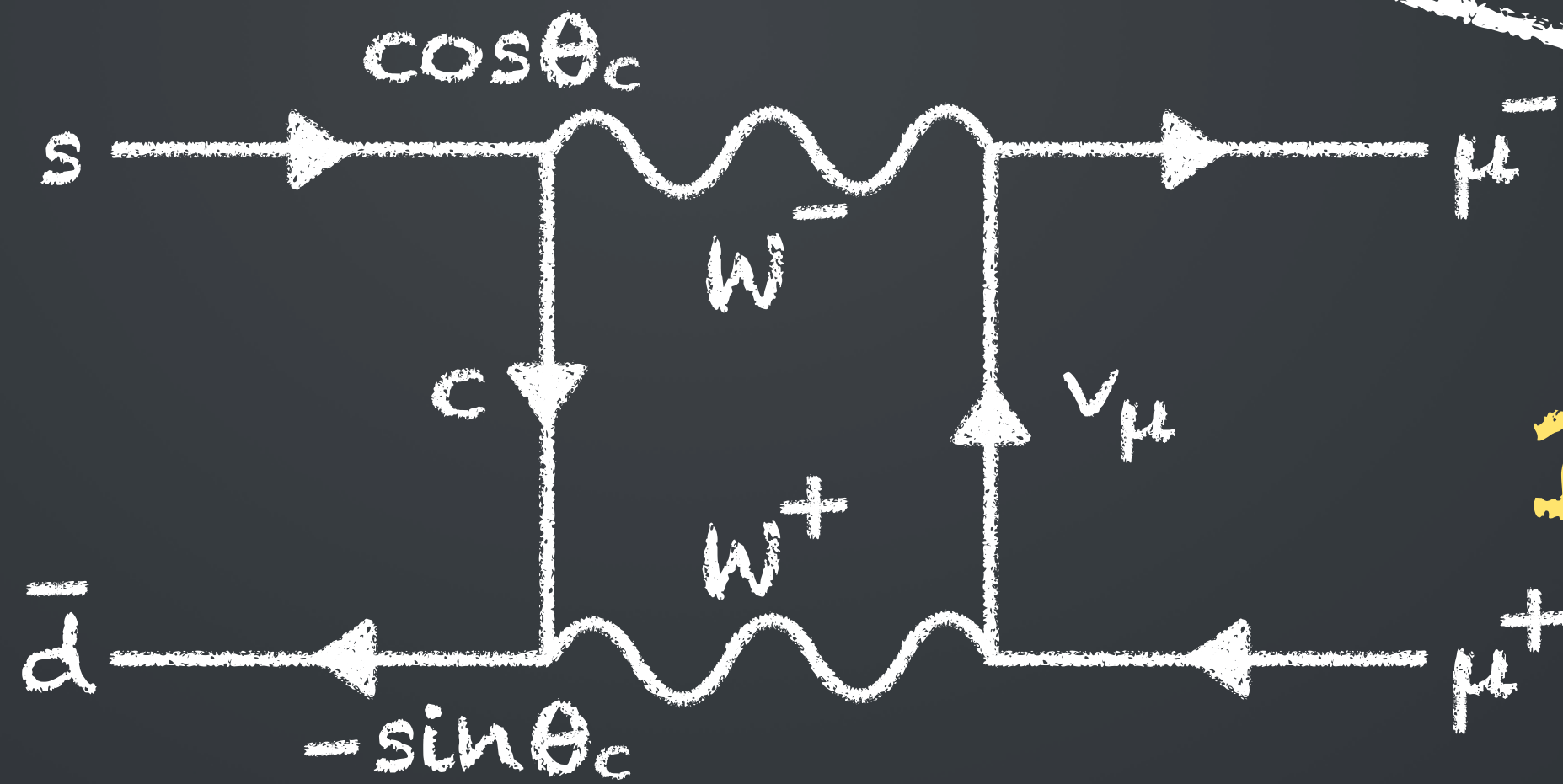
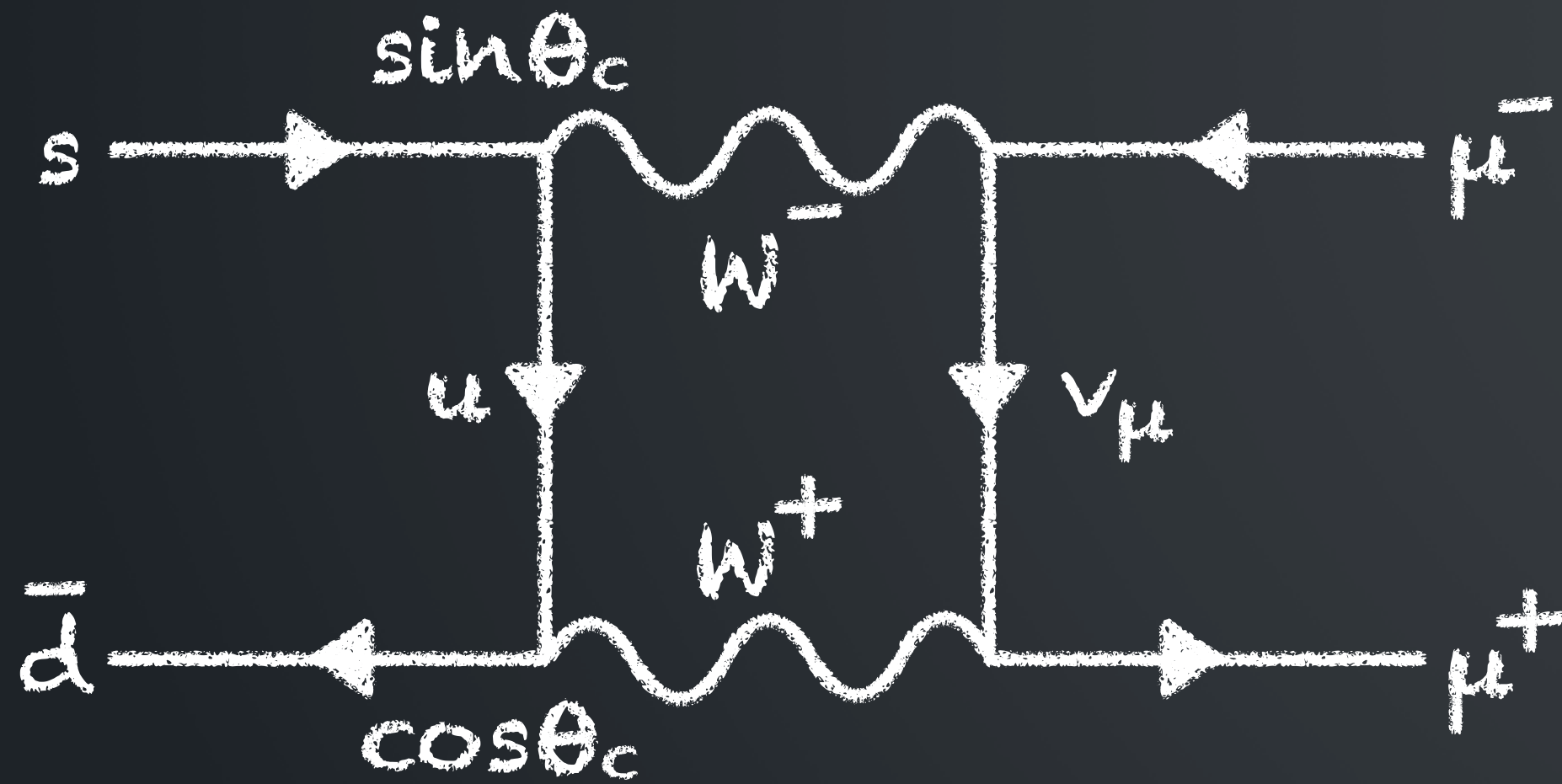

Suppression as $\sin\theta_c\cos\theta_c$ and $-\sin\theta_c\cos\theta_c$ terms cancel!



1979

Electroweak unification

Glashow, Salam and Weinberg

If there is a 4th quark, can it form particles?

The hunt is on...

Discovering charm

Dortmund
celebration
of \bar{c} charm

Richter



Stanford

$$e^+e^- \rightarrow \text{hadrons}, e^+e^-, \mu^+\mu^-$$

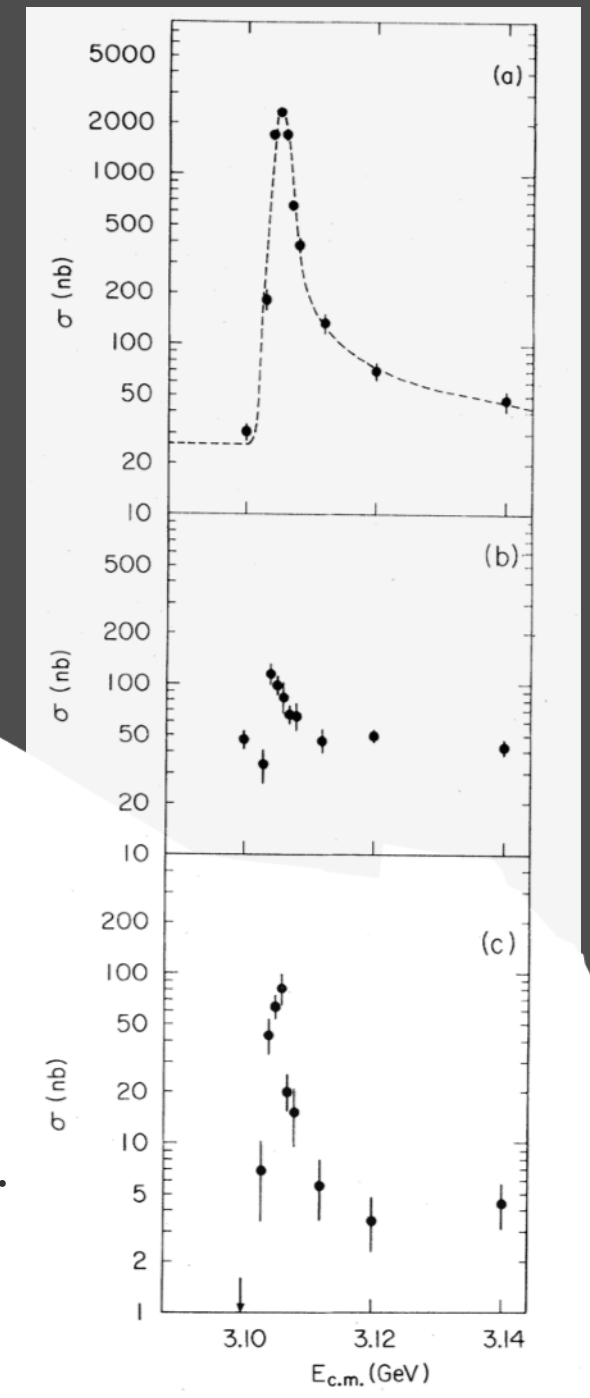

[Phys. Rev. Lett. 33, 1406]

Brookhaven

$$p + \text{Be} \rightarrow e^+ + e^- + x$$



Ting

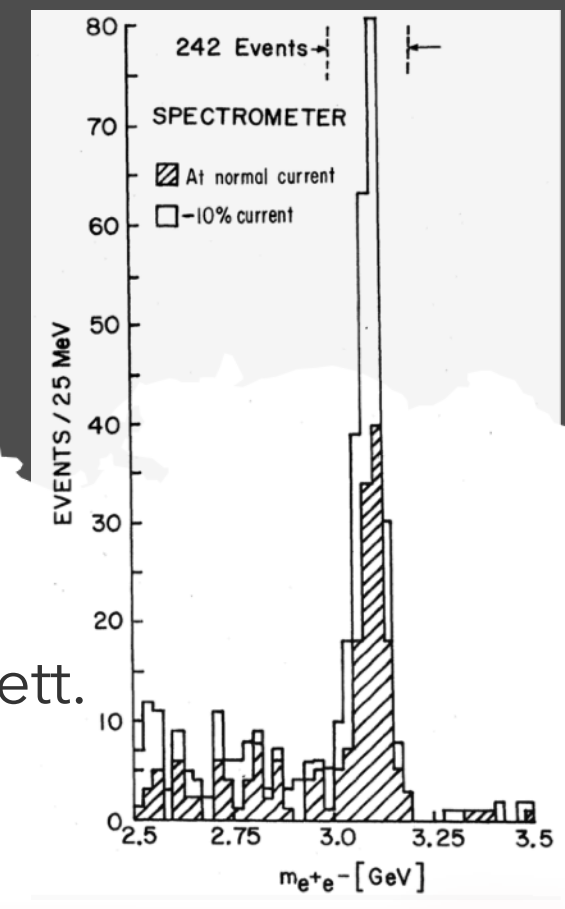

[Phys. Rev. Lett. 33, 1404]



1974: the J/ψ meson is discovered \rightarrow **the charm quark is found**

50 years of experimental charm

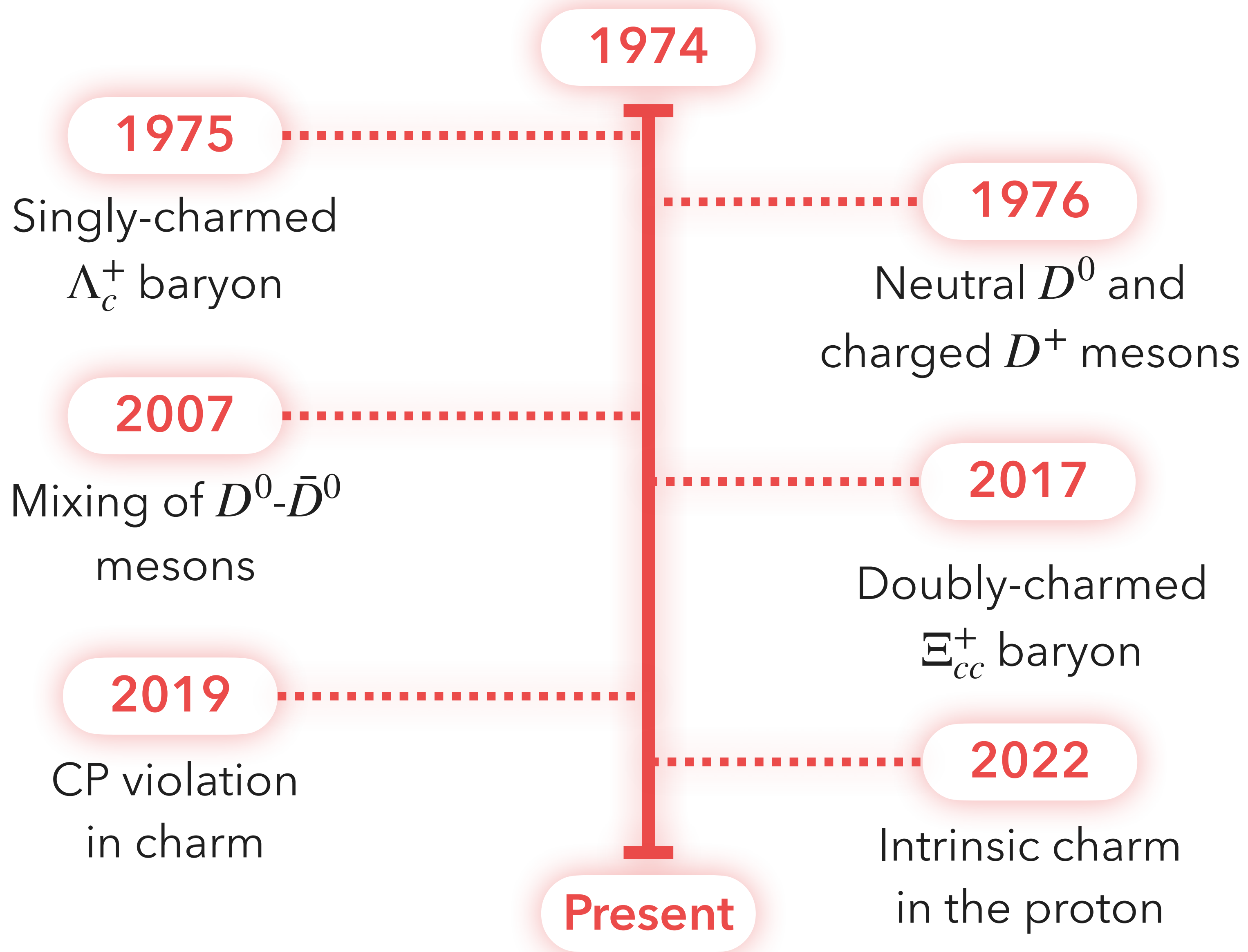

Charm at TU Dortmund

Dortmund
celebration
of \bar{c} charm

► Experiment:

- Junior Research Group lead by Dominik Mitzel
 - Measurements in charm hadron decays at LHCb



► Theory:

- Working Group lead by Gudrun Hiller
 - Studies of BSM models and symmetries for rare semi-leptonic/radiative decays of b and c quarks
- Junior Research Group lead by Emmanuel Stamou
 - BSM phenomenology, including in heavy flavour (b and c) interactions

Celebrating 50 years of charm

- ▶ Holding the “Dortmund Celebration of Charm” this year
 - String of outreach events dedicated to charm anniversary
- ▶ Many activities in the works
 - Aim to reach a broad range of audiences
 - General public
 - Local school students
 - University community (within and outside of HEP)
 - Events planned to coincide with anniversary in November
 - Public lecture planned as *main event*
 - Smaller activities in run-up also being planned
 - Social media strategy supporting events

A circular logo with a white border and a red center. The text "Dortmund celebration of charm" is written in white, with "Dortmund" in a larger font and "celebration of charm" in a smaller font below it.

Dortmund
celebration
of charm

Planned events

- ▶ Plan to hold most events in November, around anniversary date
- ▶ Core event → public lecture:
 - Either on campus or in Dortmund, depending on level of interest
 - Would like to also involve key figure in charm history (TBC)
- ▶ Possible peripheral events:
 - Stand at university open day (Tag der offenen Tür)
 - Tie-in with masterclasses

*D*ortmund
celebration
of \bar{c} charm

Social media strategy

- ▶ Ramped up social media presence in past months
 - Accounts on X (formerly Twitter) and Instagram refreshed
 - Visual identity updated; unique visual identity for the charm celebration
 - Regular cross-platform posting
- ▶ Currently playing back the last 50 years in each post

Follow us: @dortmund_lhcb

**D⁰rtmund
celebration
of \bar{c} charm**



Conclusion

- ▶ 50 year anniversary as good a time as ever to celebrate rich charm history
- ▶ Charm is a key part of the Dortmund particle physics research programme
- ▶ Outreach programme planned to celebrate anniversary
 - Direct activities planned for November
 - Indirect activities (e.g., social media) already underway

Thank you for your attention

*D*ortmund
celebration
of \bar{c} charm

Follow us:

@dortmund_lhcb



Dortmund Celebration of Charm

Celebrating 50 years of
experimental charm physics

Johannes Albrecht, Jamie Gooding,
Dominik Mitzel, Donata Osthues, Luca Toscano
Fakultät Physik, TU Dortmund

7th March 2024, Session T 88.6

DPG Spring Meeting 2024, Karlsruhe

*D⁰*rtmund
celebration
of \bar{c} harm

