



AWAKE Run2c vs Run2a&2b Infrastructure Integration

Integration Team: A. Pardons, E. Guran, V. Clerc (3D Drawings)

Update from 2020 document (P. Wiwattananon)

Run 2ab vs Run2c

- Run2c has 2 times large/complex equipment than Run2ab
- Run2c requires at least x2 spaces/volume than Run2ab
- In Run2c integration design →take into account: the accessibility of equipment – obey rule for minimum passage (800mm width free) for emergency evacuation
- In Run2c integration design →take into account: the transportation of equipment to the AWAKE experimental area: transportation width = 1.3m

TAG41

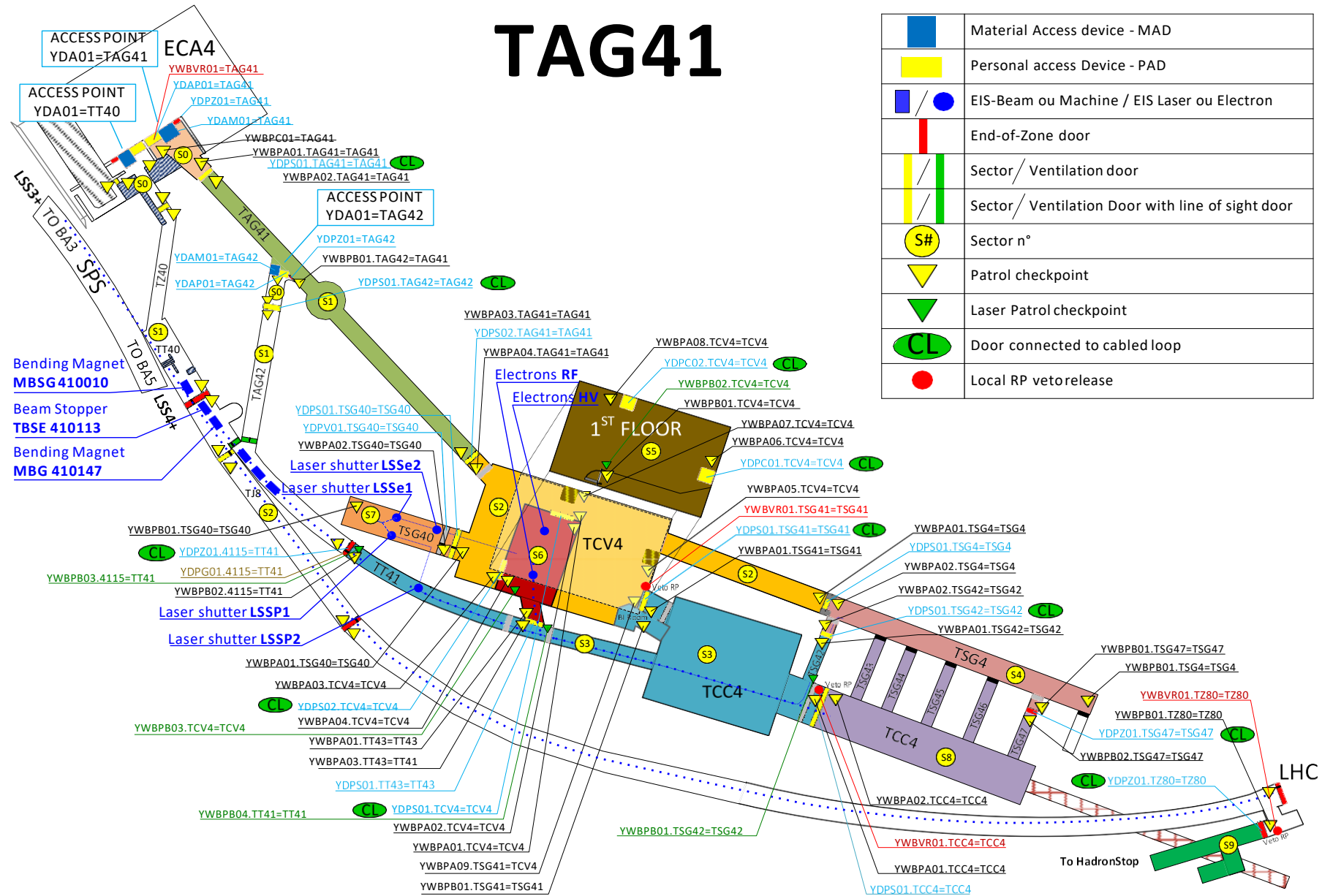

Run2c vs Run2ab

Slide 5: Run2ab Experimental Area

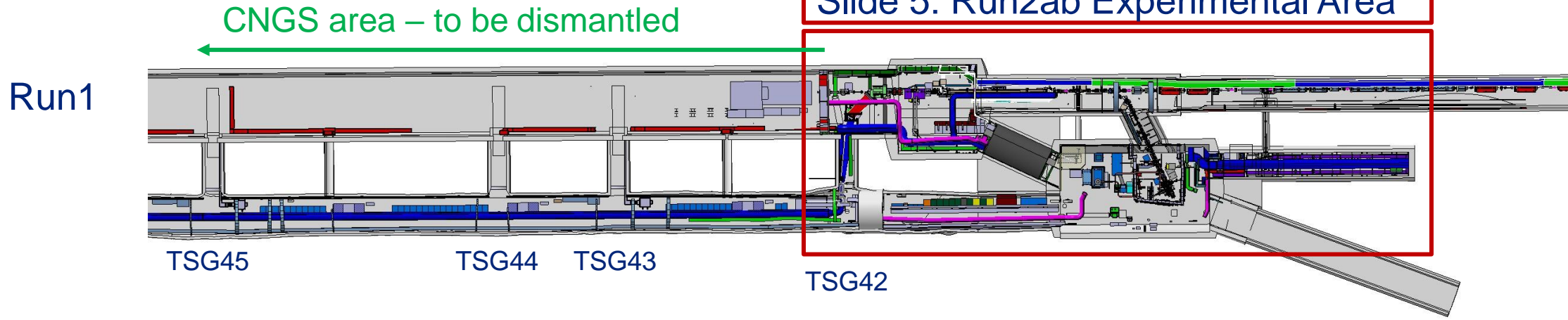

AWAKE CNGS Area Dismantling is before & during LS3 (2025-2026)
 Run2c Integration/installation is during LS3 (2026-2027)

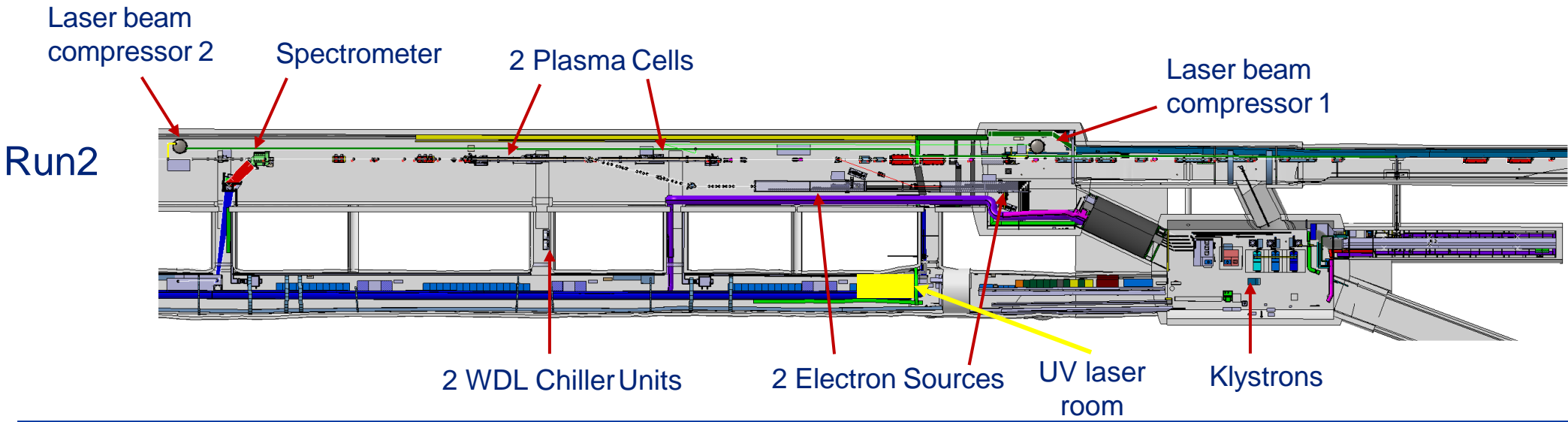

Run 2ab

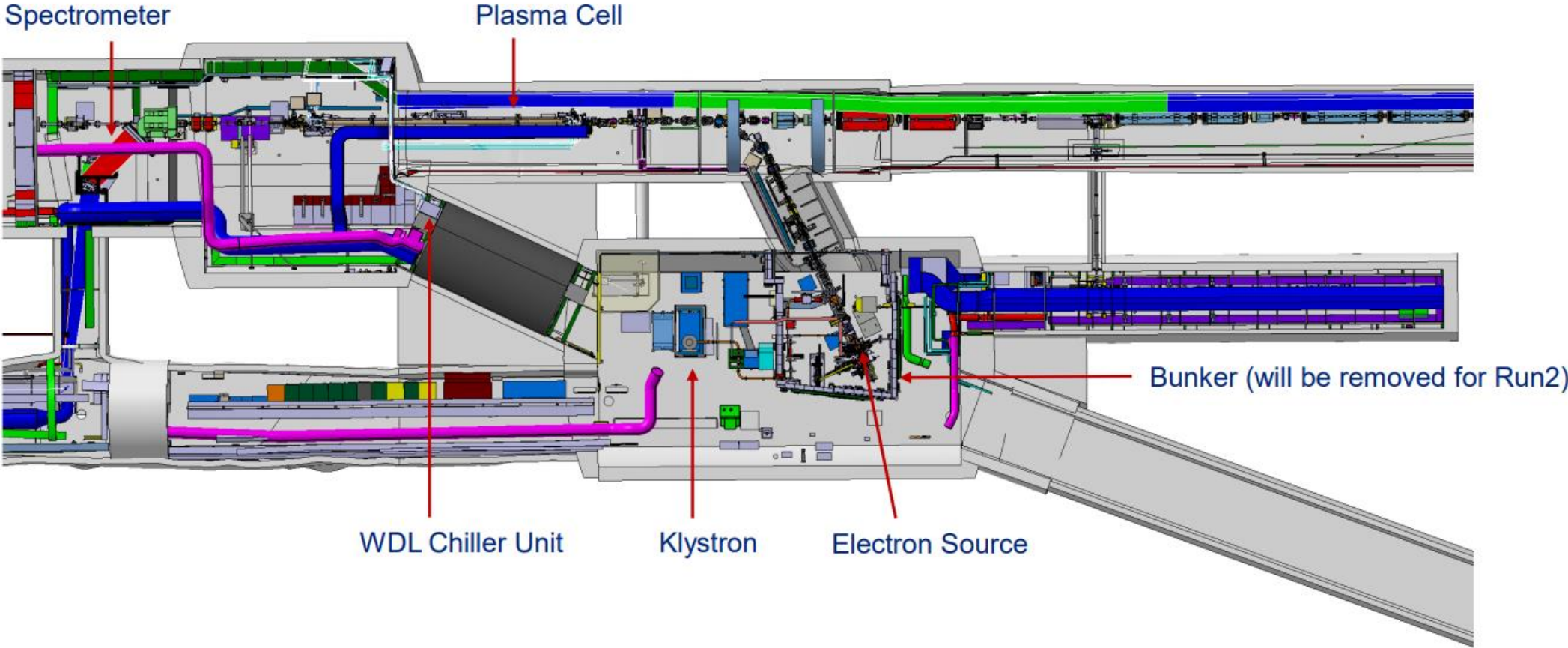

AWAKE Run2ab – Transportation Path

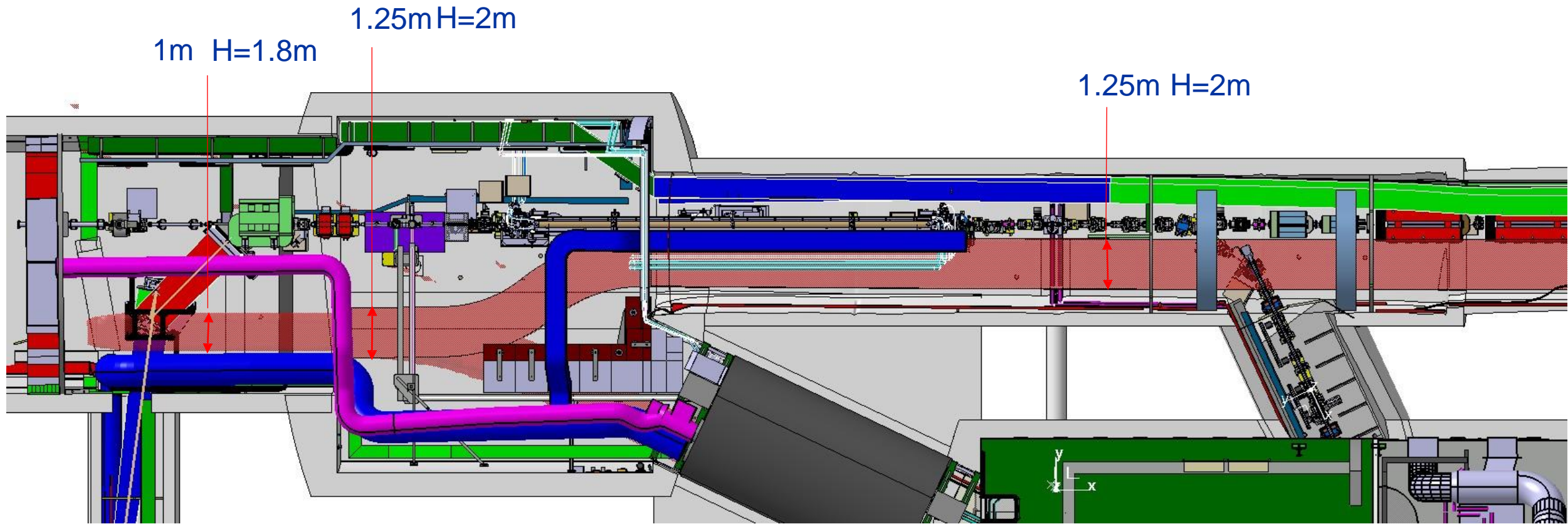

Extra Slides AWAKE Run2c

Run2c Plasma Cell1 Moves 40m Downstream Relative to Run1 Plasma Cell

AWAKE Run2c Infrastructure

AWAKE Run2ab

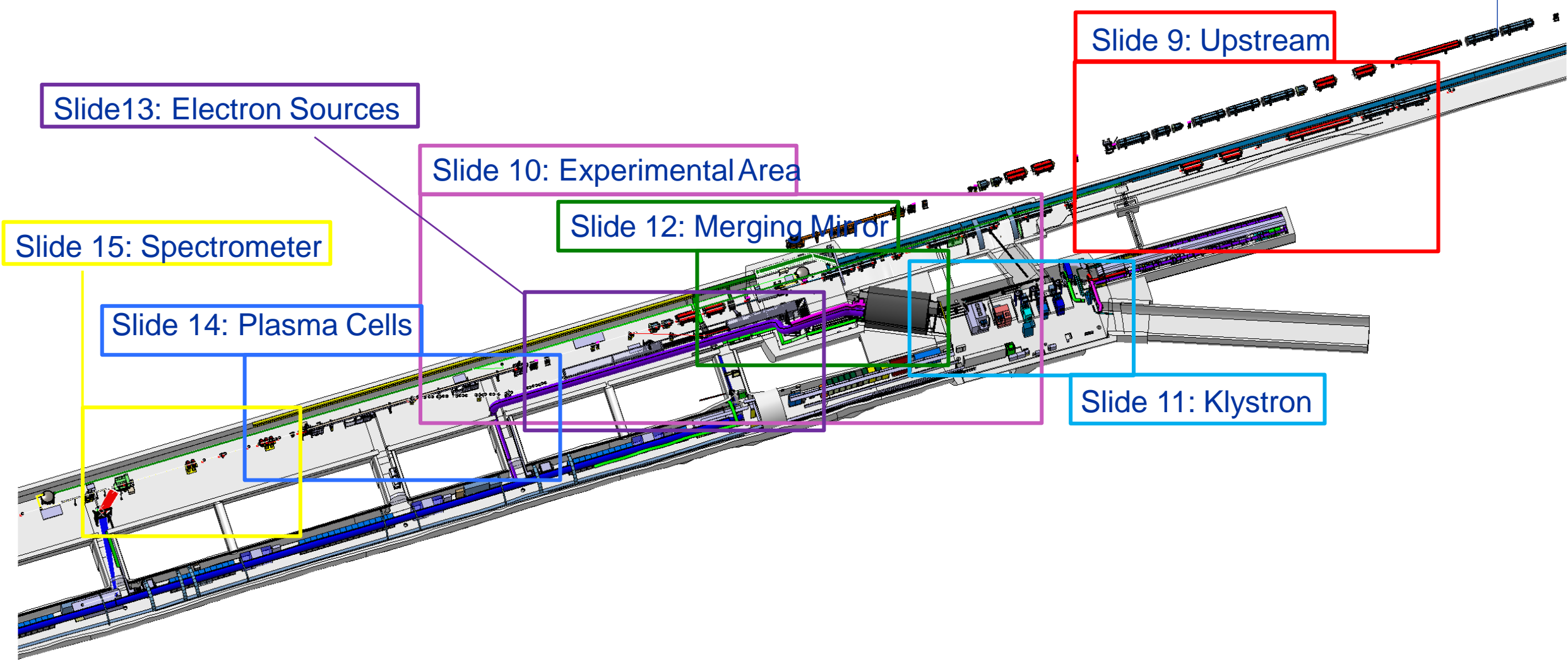

Upstream – TT41

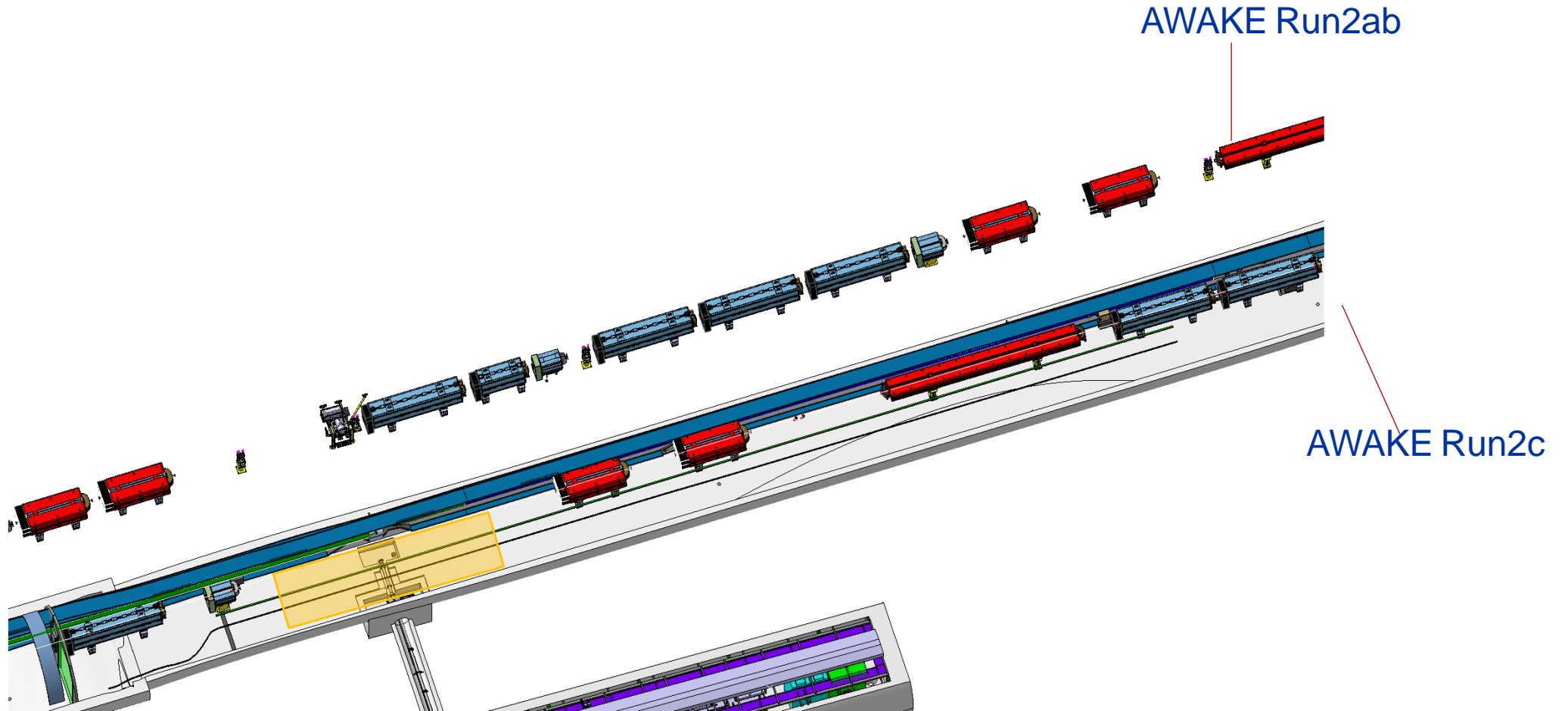

Laser Merging Mirror Equipment → move 35m downstream relative to Run2ab position.
Proton beam magnets → relocate to support the Run2c plasma cell1 location and avoid conflicts with infrastructure, e.g. doors, in the tunnel.

BEAM HEIGHT – TT41

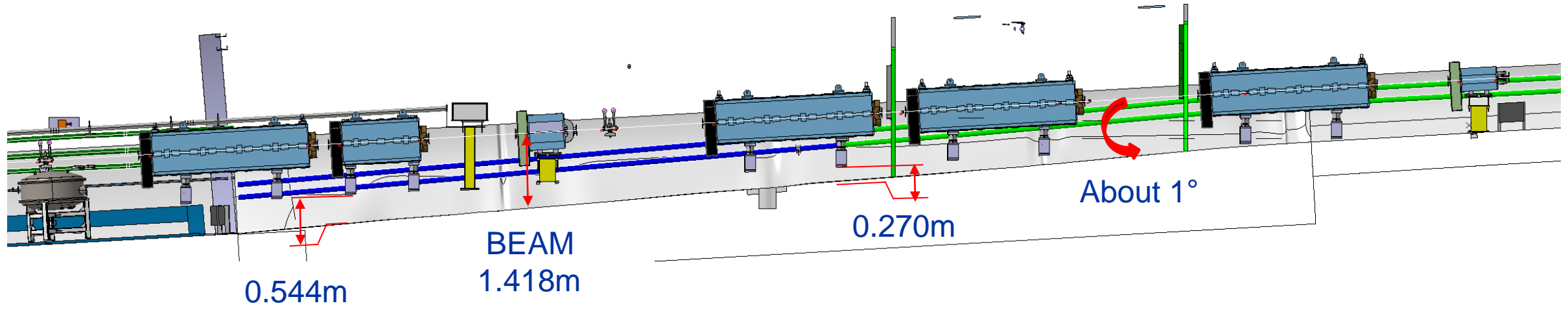

Experimental Area – TCC4

AWAKE Run2ab Plasma Cell

AWAKE Run2c Plasma Cell1

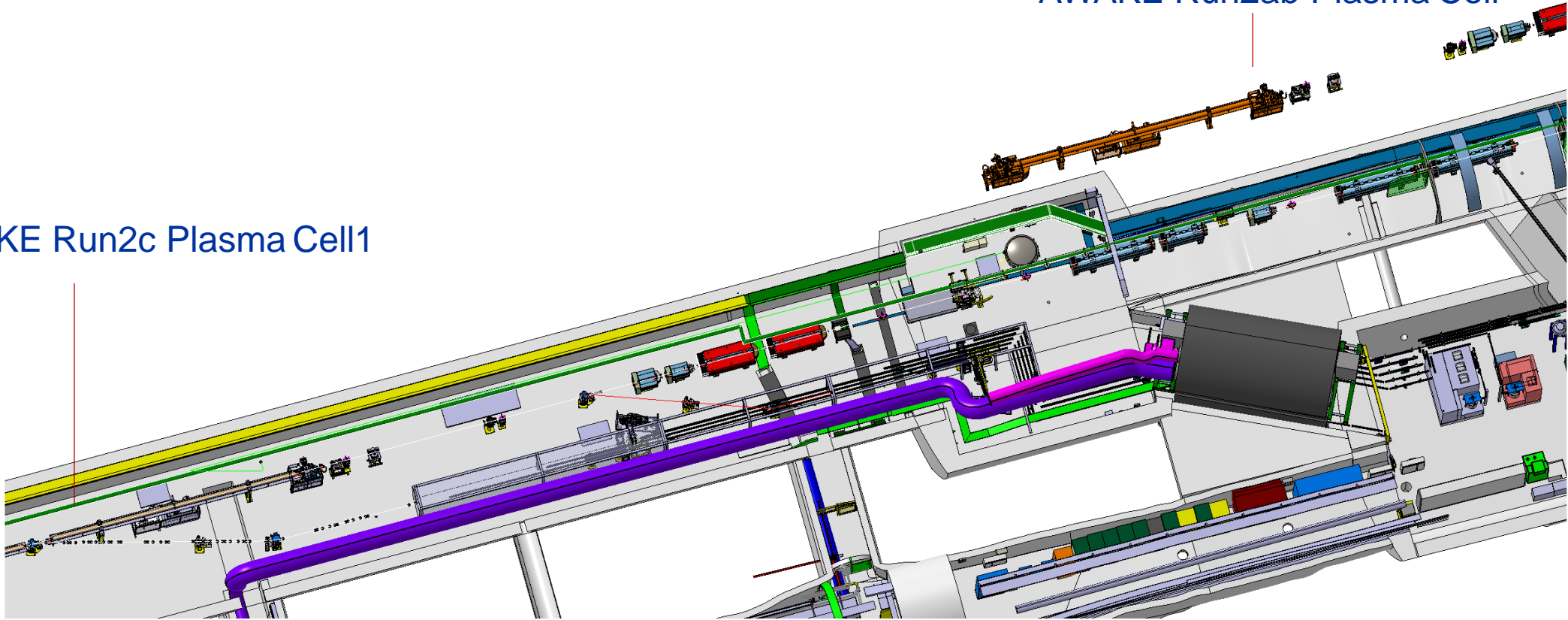

AWAKE Run2ab Plasma Cell moves 40m downstream → AWAKE Run2c Plasma Cell1

Working spaces around the laser merging mirror, compressor1, and electron sources obey the safety passage rule!

Klystrons - TCV4

Transportation Path

TSG41

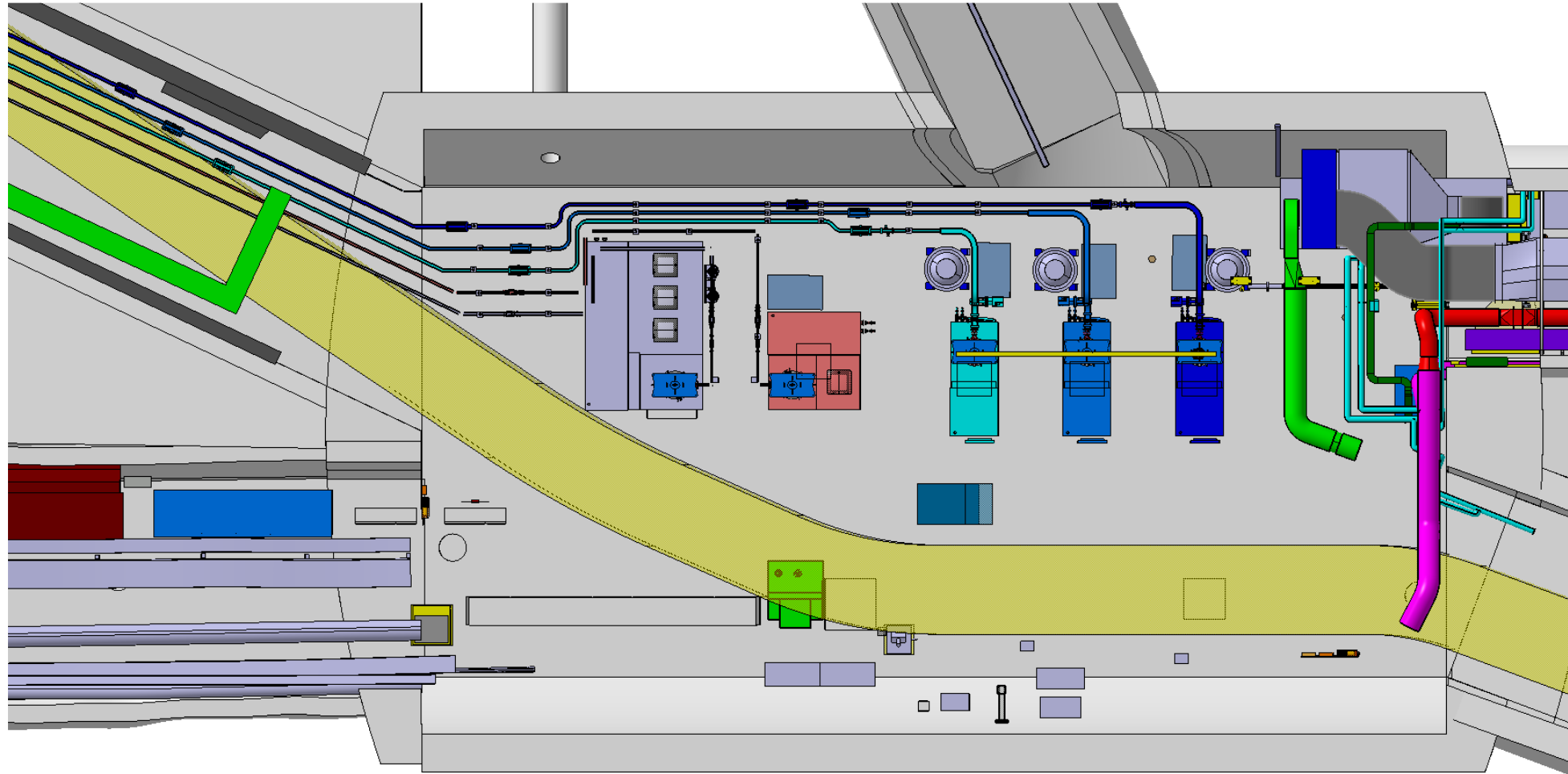

Double spaces required for Run2c (additional) klystrons → TCV4 allows a perfect location with optimum waveguide length.

Laser Merging Mirror Area – TCC4

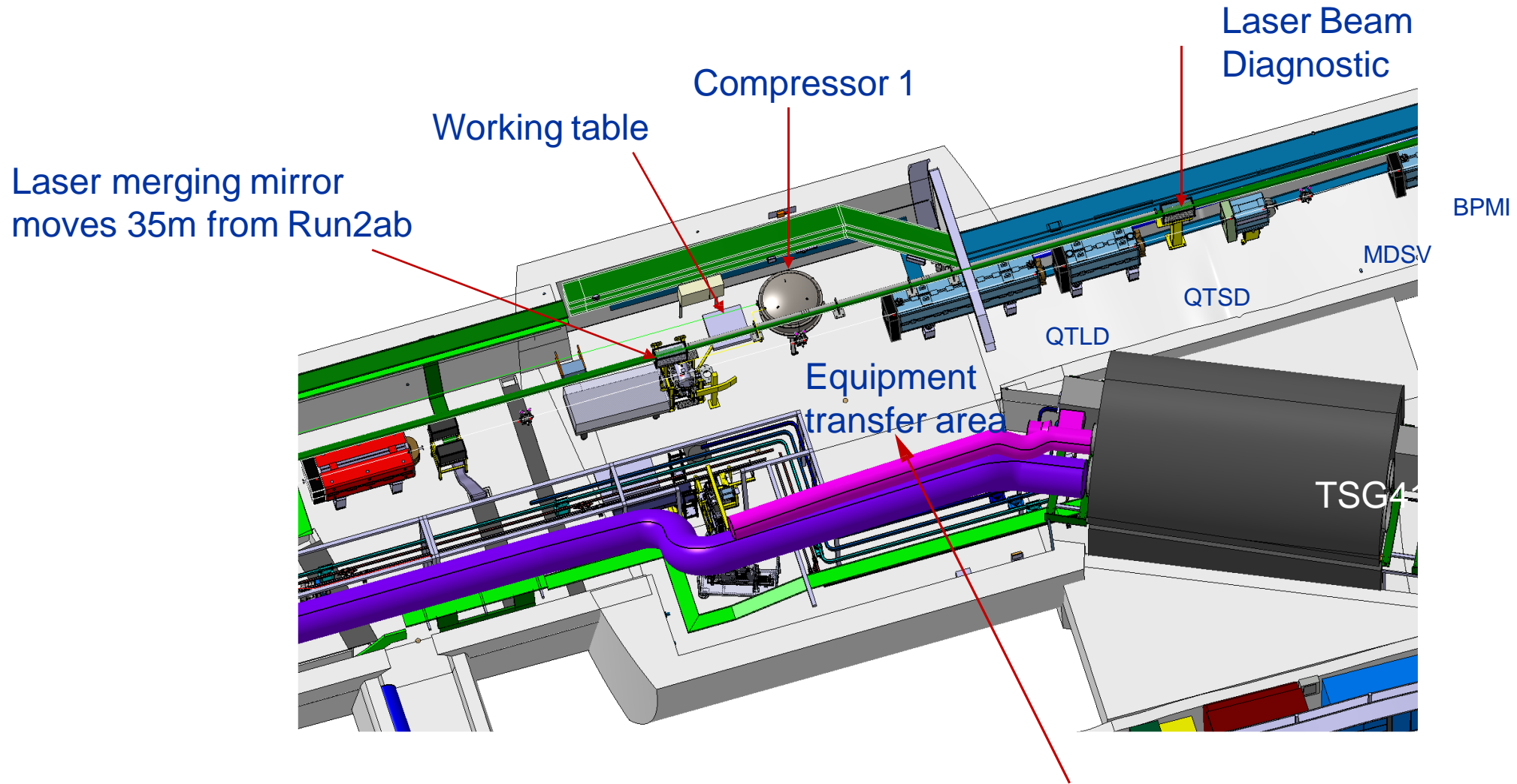

Laser merging mirror moves 35m from Run2ab

Sufficient transfer (area) of equipment to the trailer.

Electron Sources – TCC4

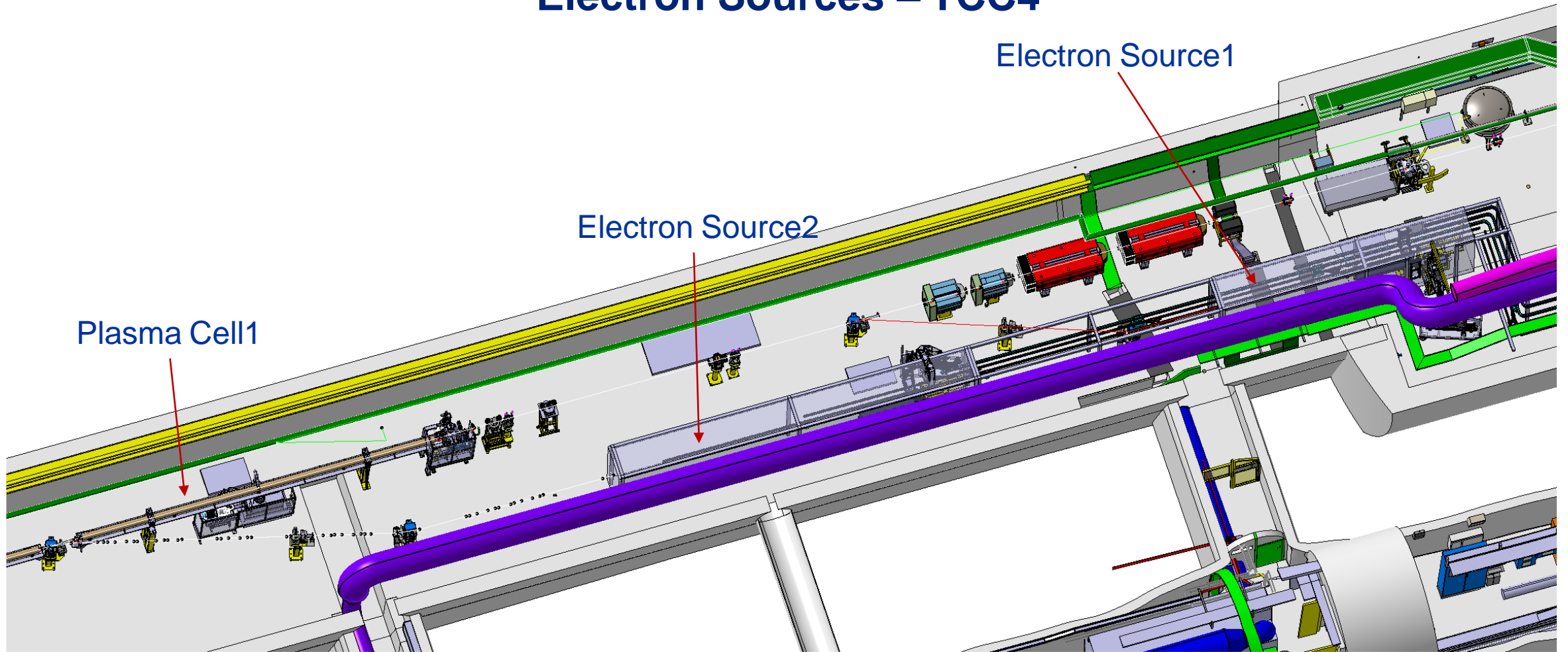

Working spaces around the electron sources obey the safety rule!
Electron beams geometries obey technical requirements.

BEAM HEIGHT – TCC4 – BEFORE PLASMA CELL

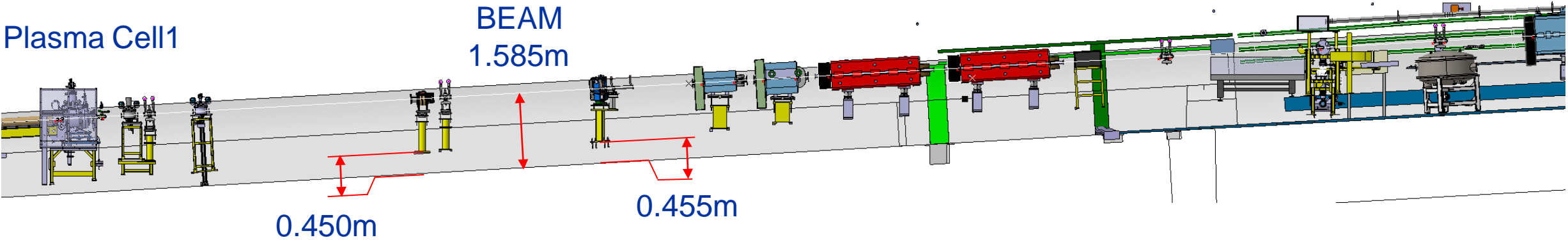

Plasma Cells – TCC4

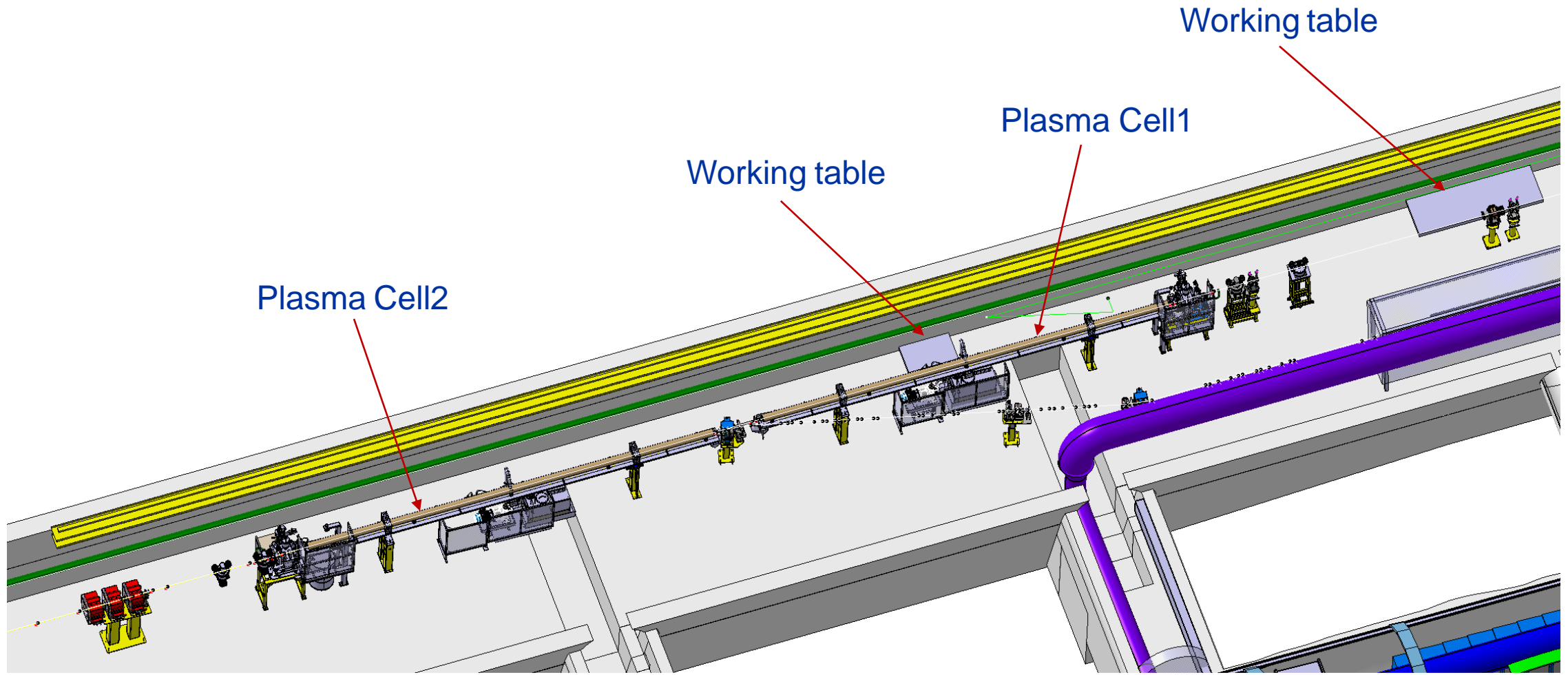

Spectrometer – TCC4

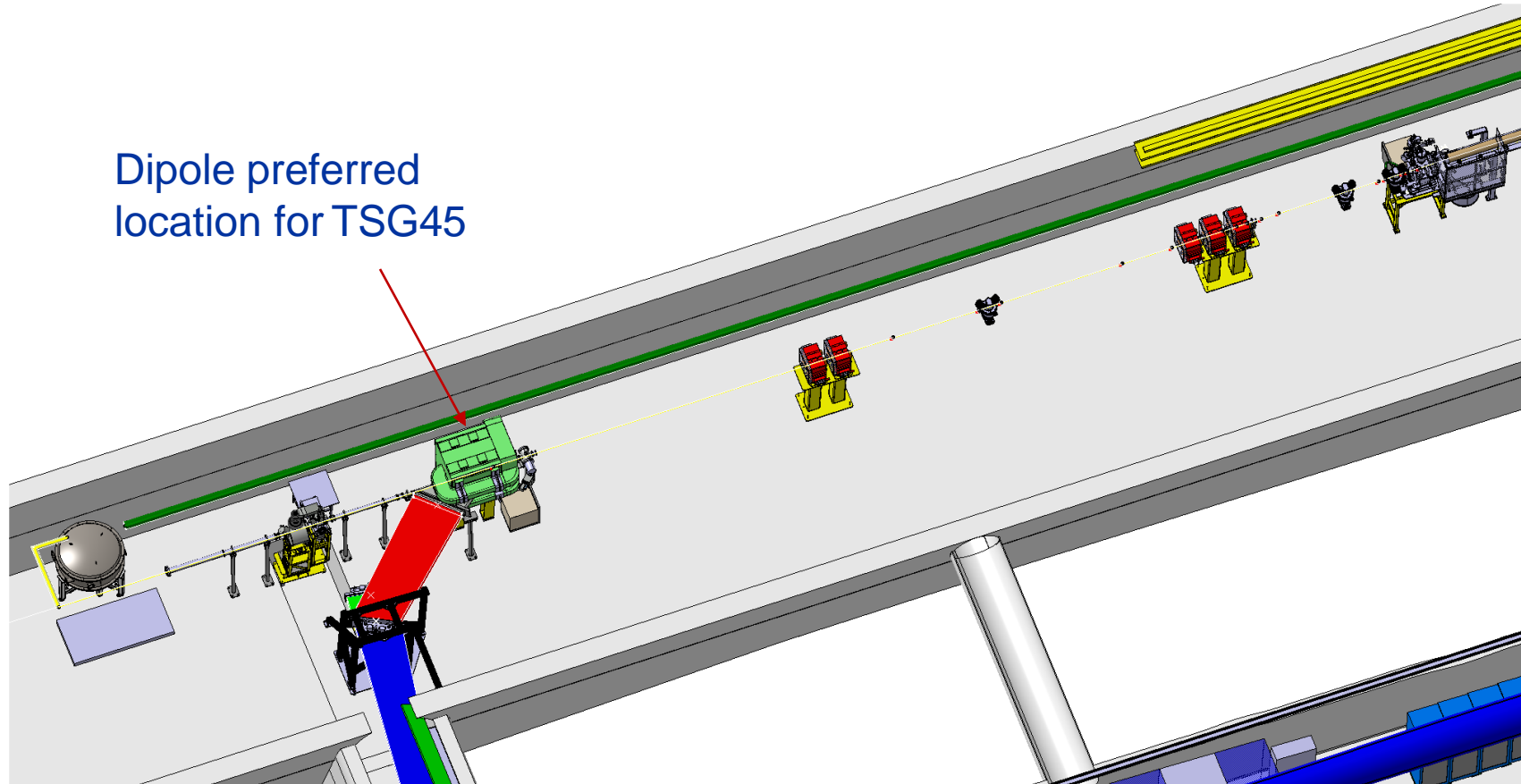

Dipole preferred
location for TSG45

TSG45

BEAM HEIGHT – TCC4 – AFTER PLASMA CELL

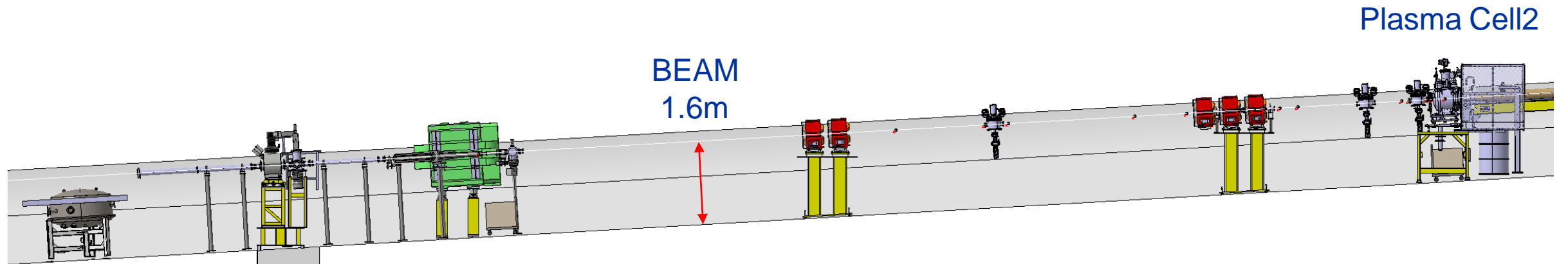

Available Space Downstream

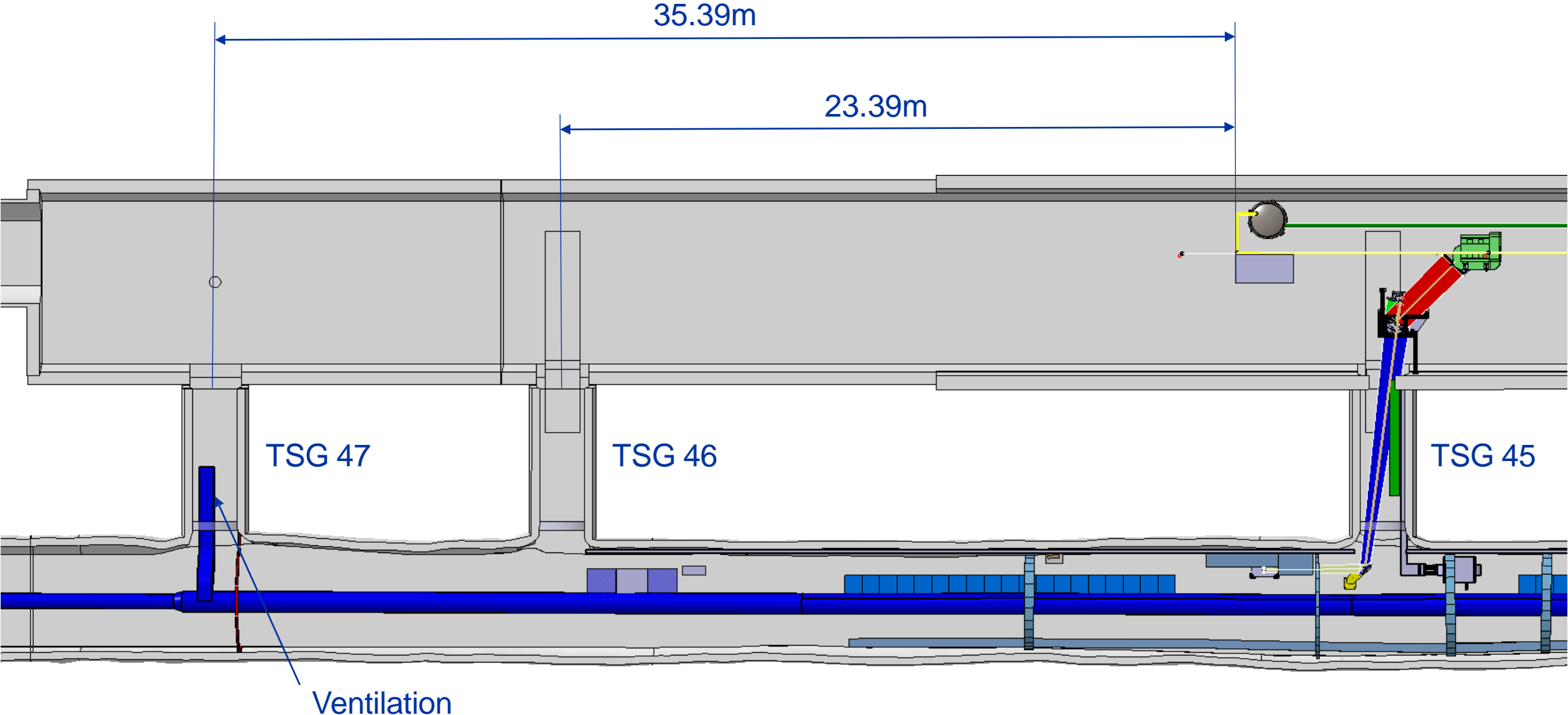

Transportation

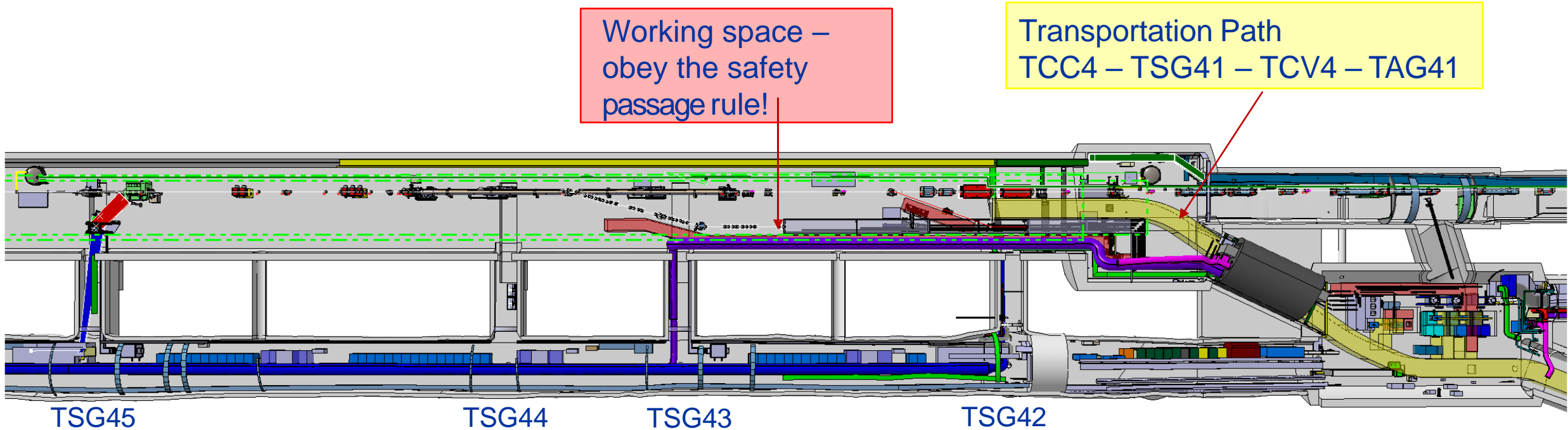

Transportation of Large/Complex Equipment:

- ✓ **Plasma Cells:** via TAG41, TAG42 and TT41 - follow Run2ab procedures.
- ✓ **Electron Sources:** via TSG41, TCV4, TCC4 – follow Run2ab transportation procedures.
- ✓ **MBXFD (dipole) at the spectrometer:** follow Run2ab transportation procedures.
- ✓ **Klystrons:** subcomponents must be assembled at the TCV4. No foreseen transportation issues.

✓ Discussed, no blocking points.

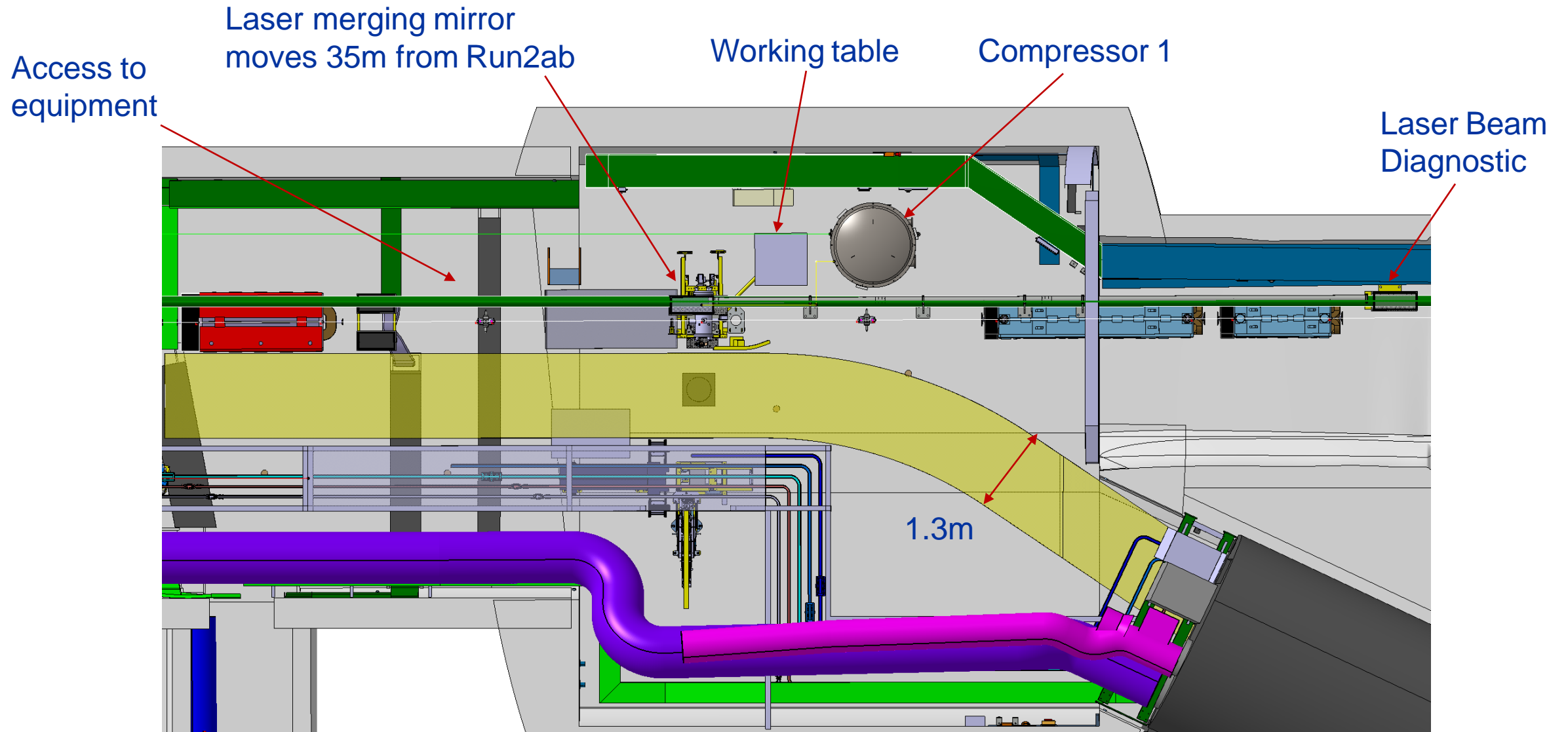

Meet required transportation width of 1.3m.
 No equipment conflicts.

TCV4

TSG41

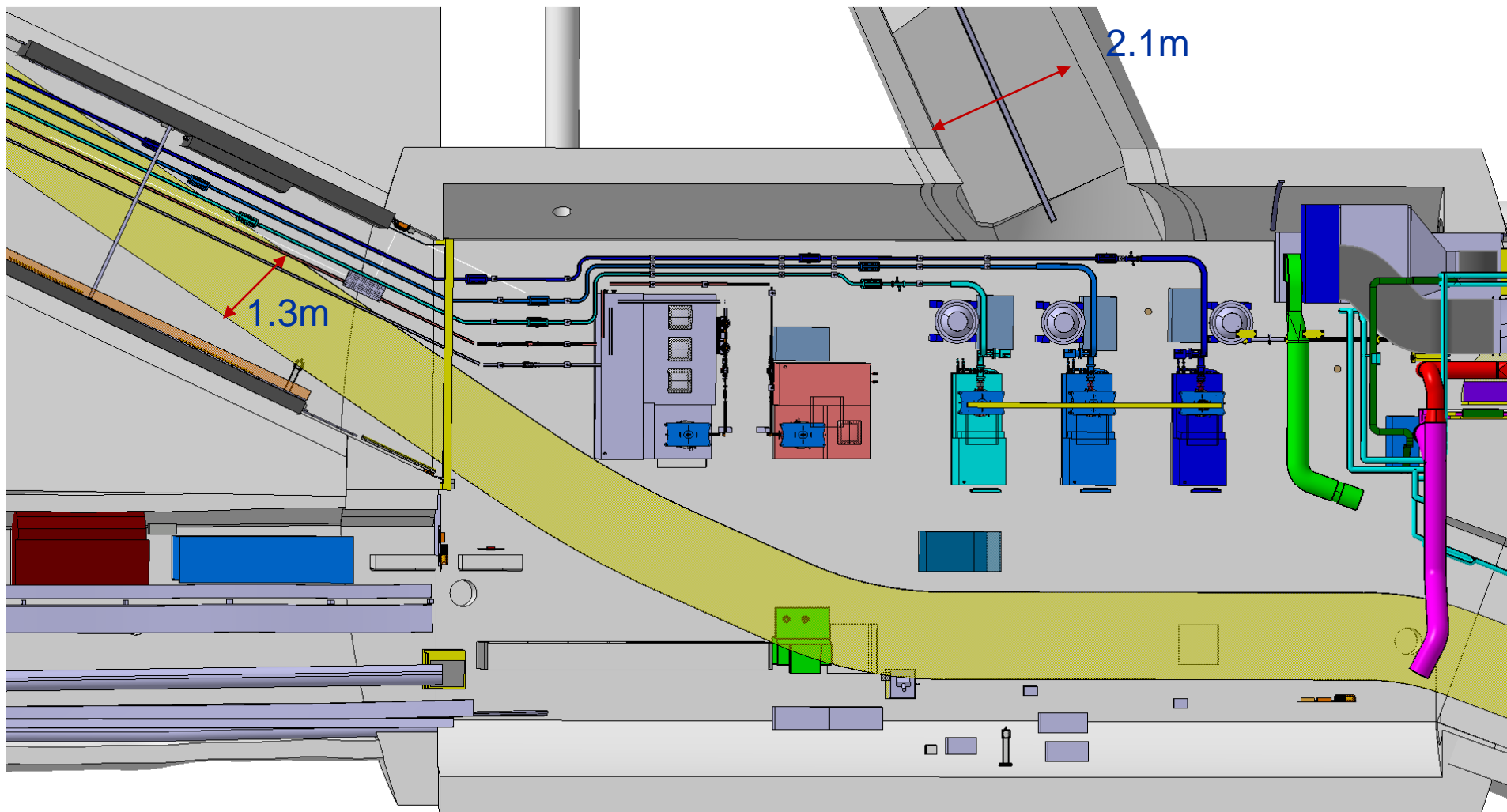

Klystron subcomponents can be transported via TAG41 and assembled onsite at the TCV4.

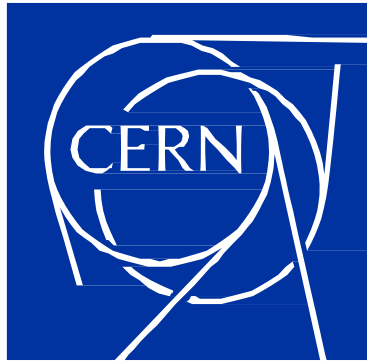

home.cern