

# Telescopi ottici

Adriano Fontana

INAF Osservatorio di Roma

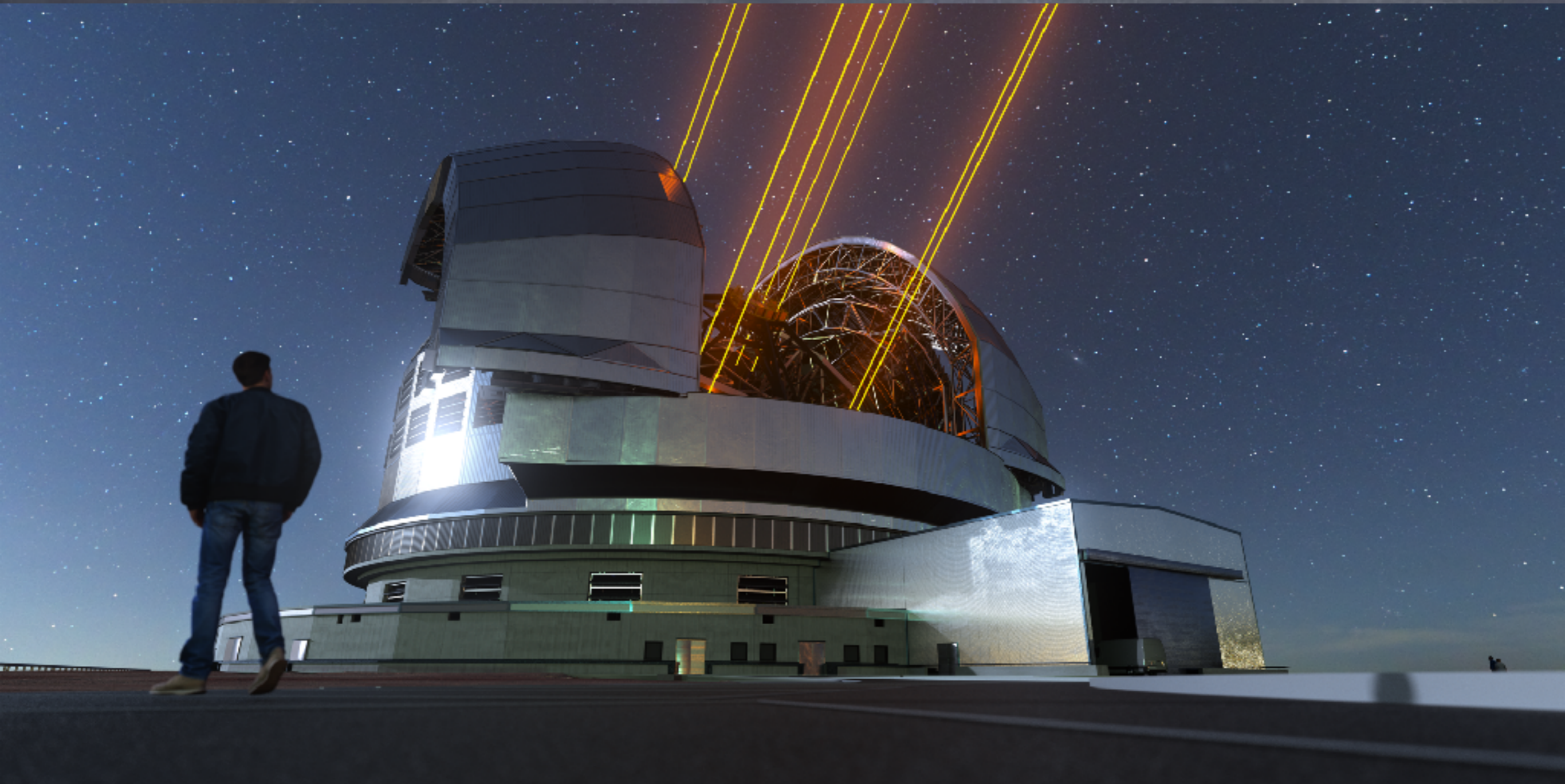

# A brief history of the telescope..

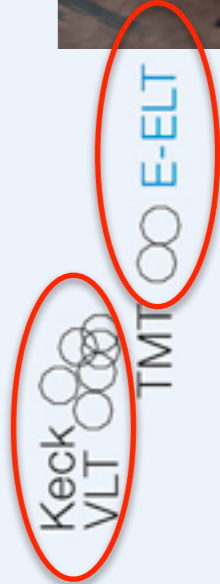
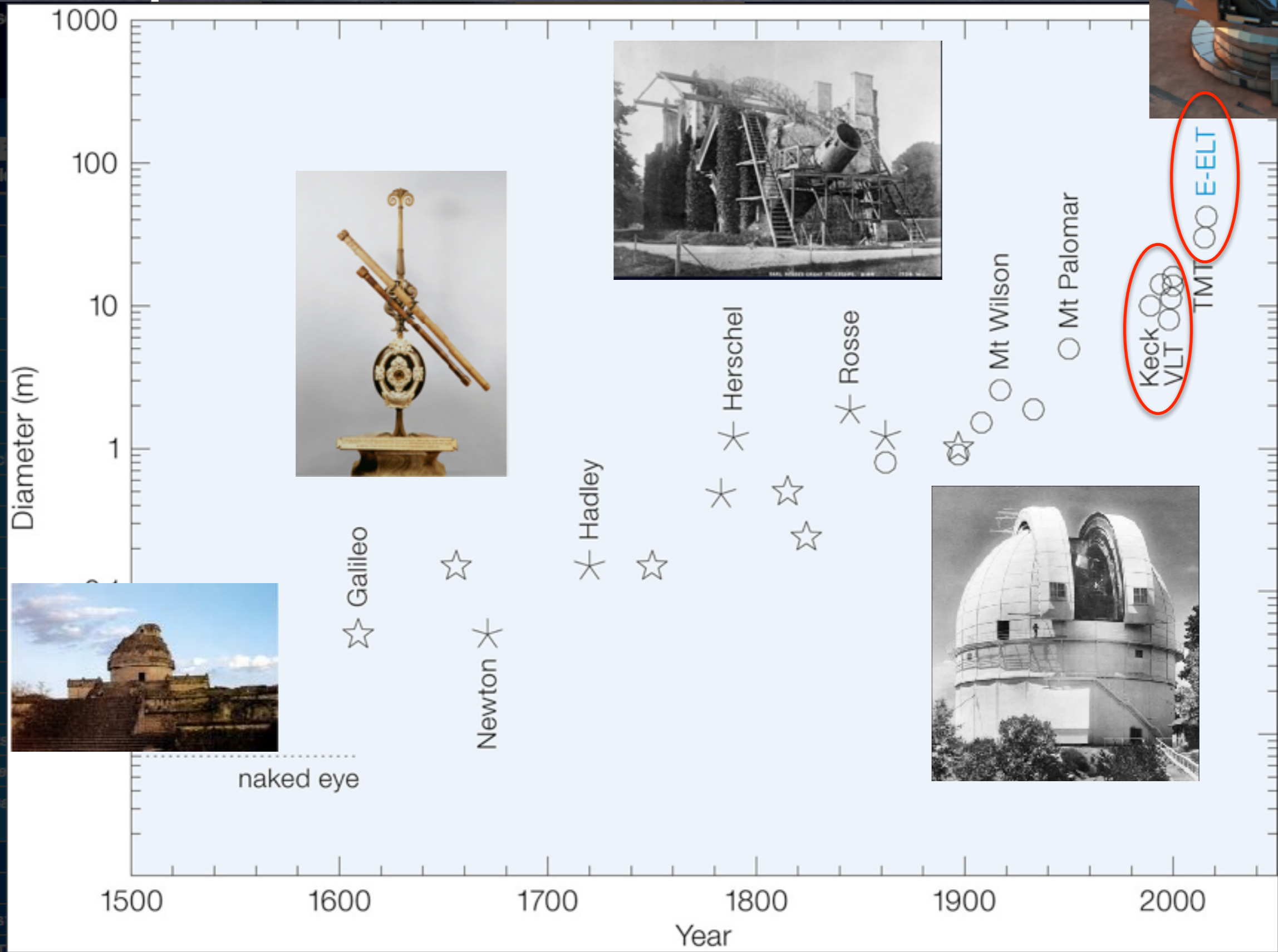

# Perchè si chiamano telescopi “ottici”?

## The Earth's Atmosphere (I)

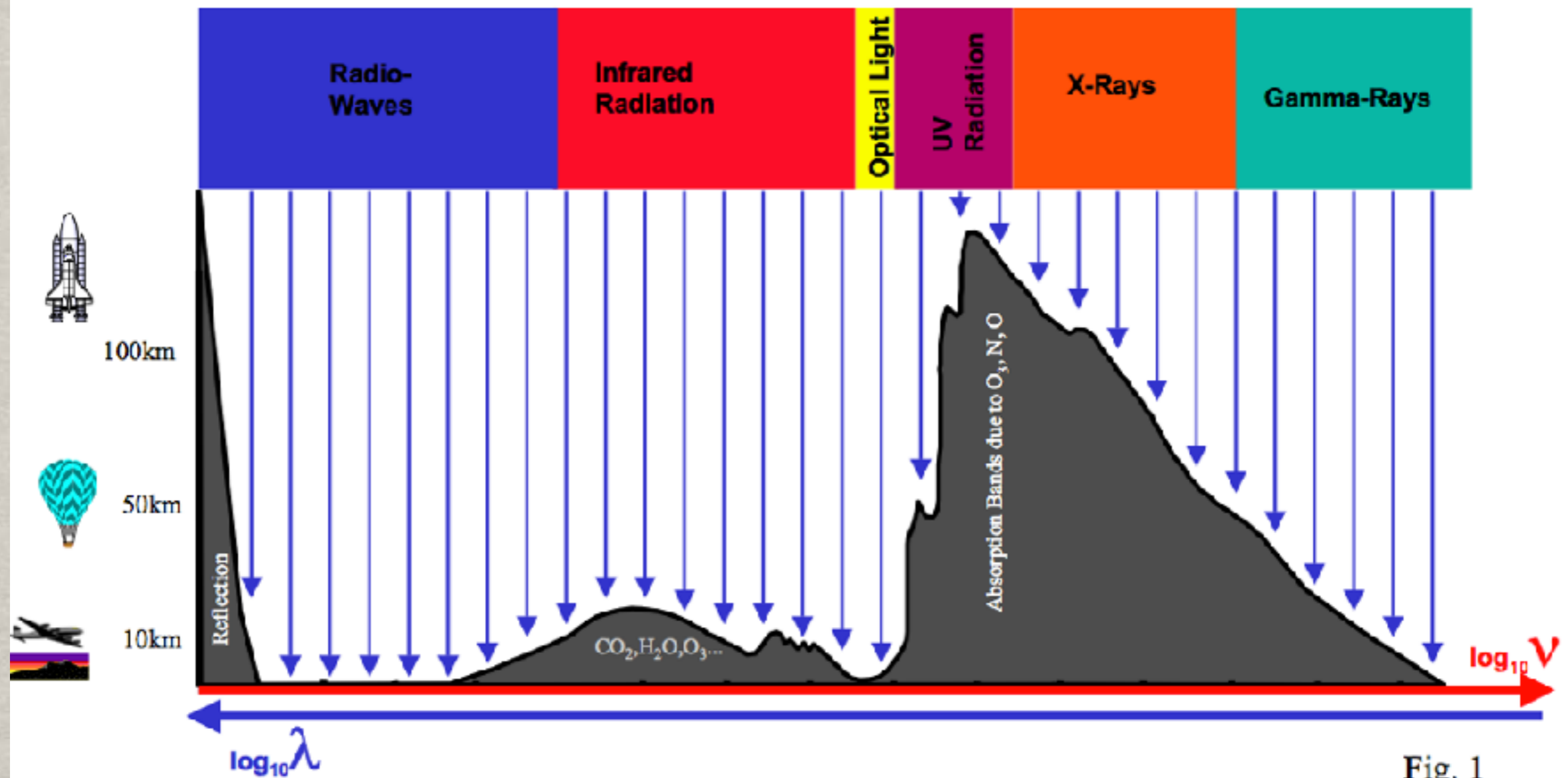
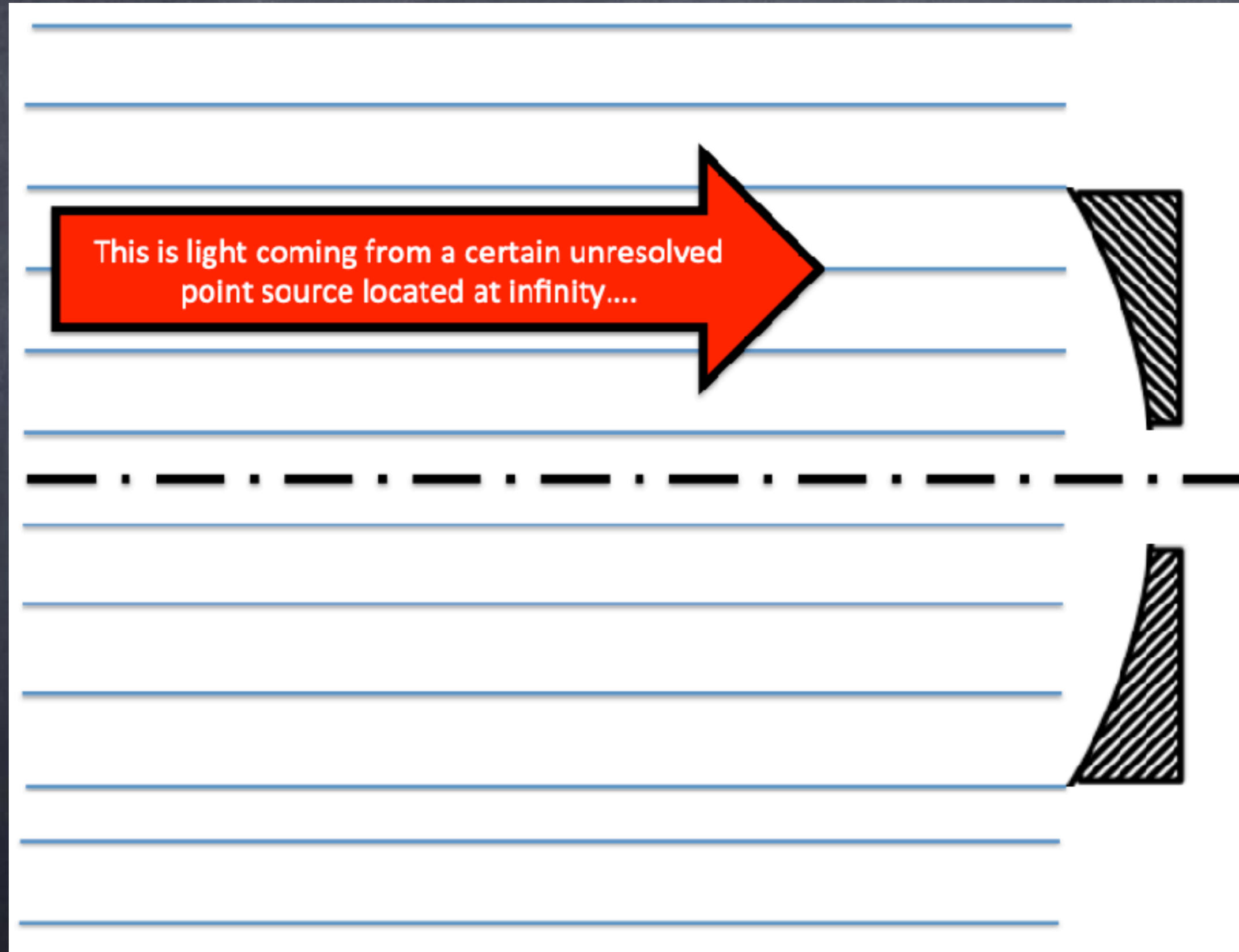

Fig. 1

Observations from the ground are only possible in certain frequency ranges, caused by the variation of atmospheric transparency with frequency.

# Come sono fatti i telescopi (ottici)?



Come sono fatti i telescopi (ottici)?

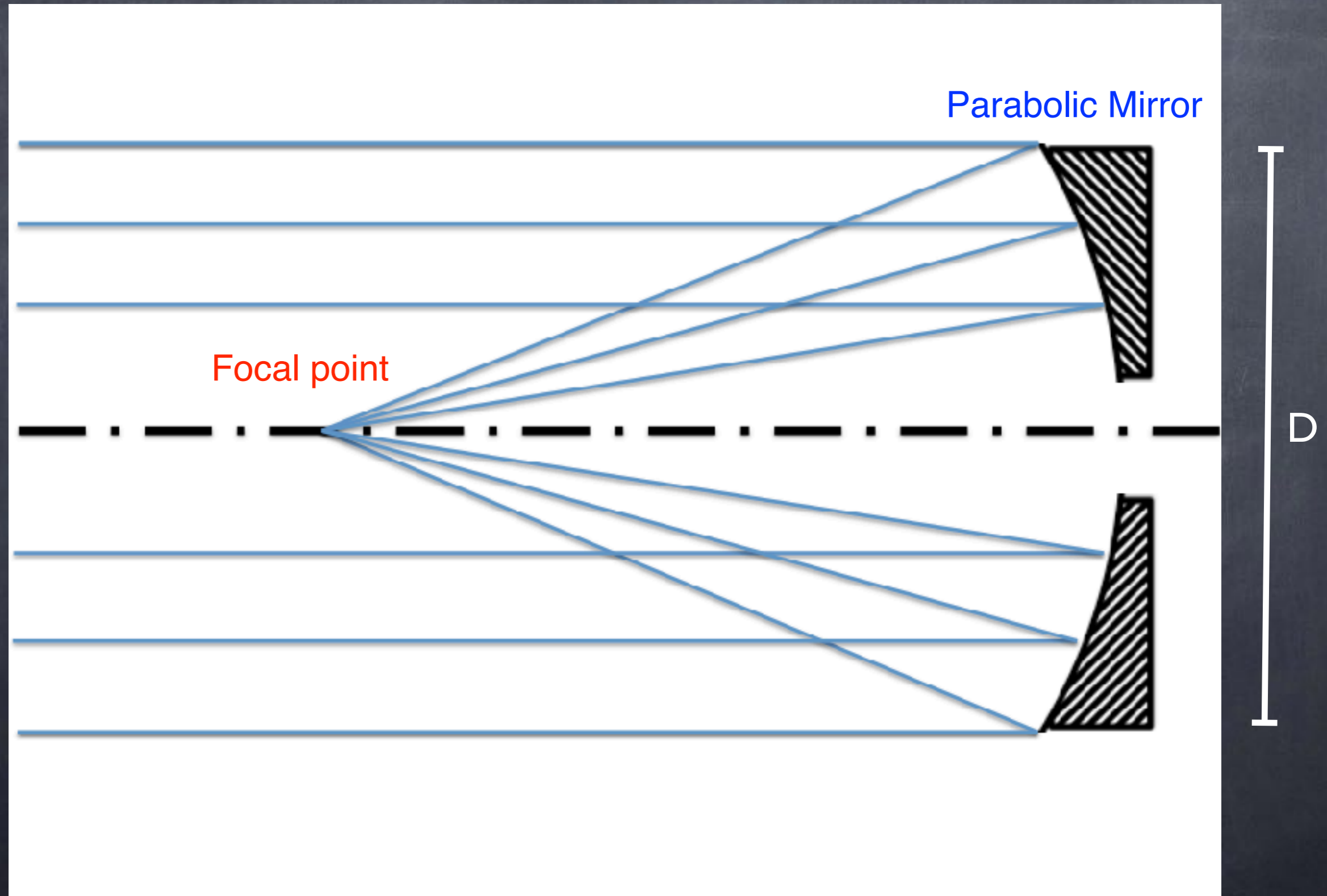

# Come sono fatti i telescopi (ottici)?

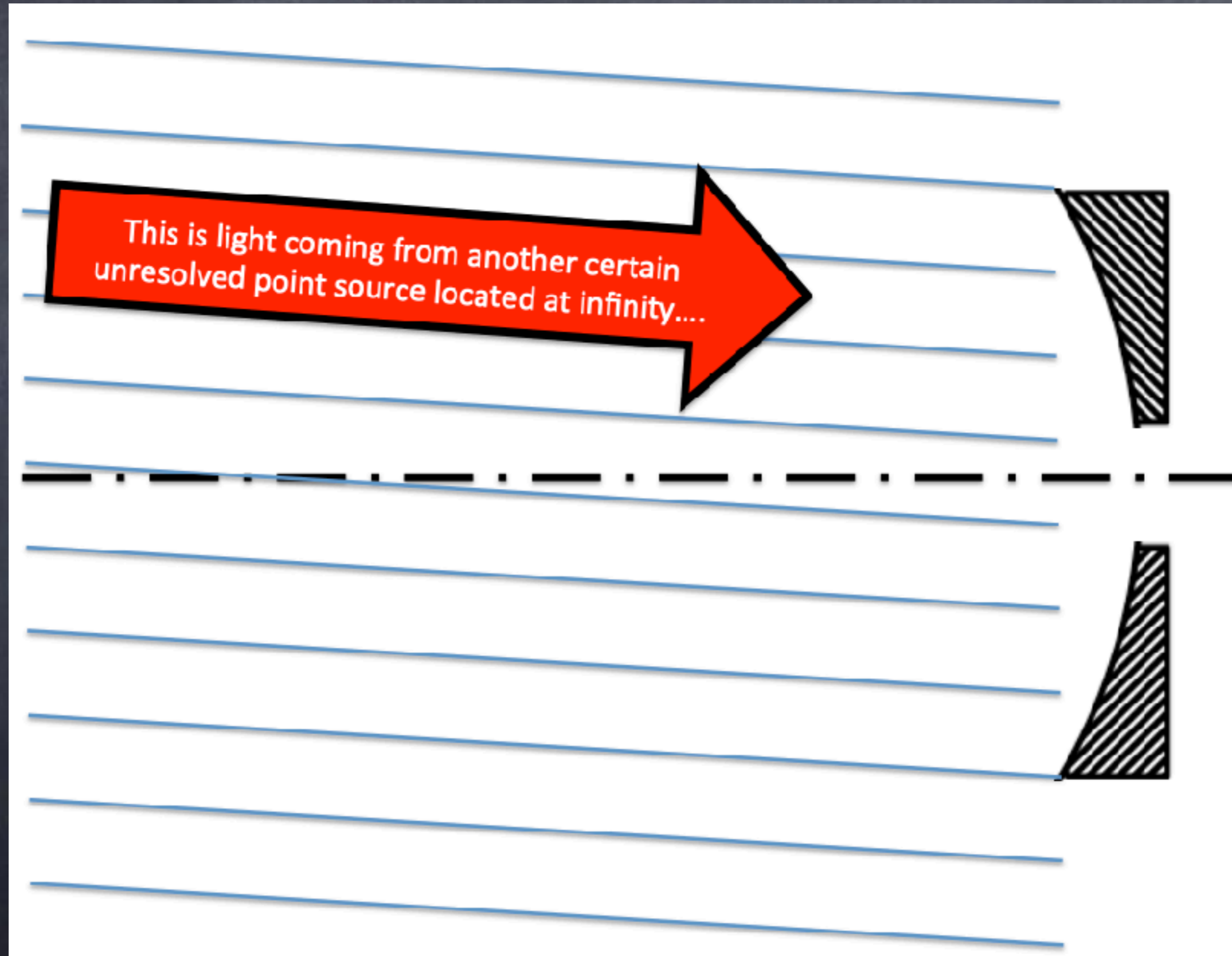

Come sono fatti i telescopi (ottici)?

And this is where it focus an off-axis source

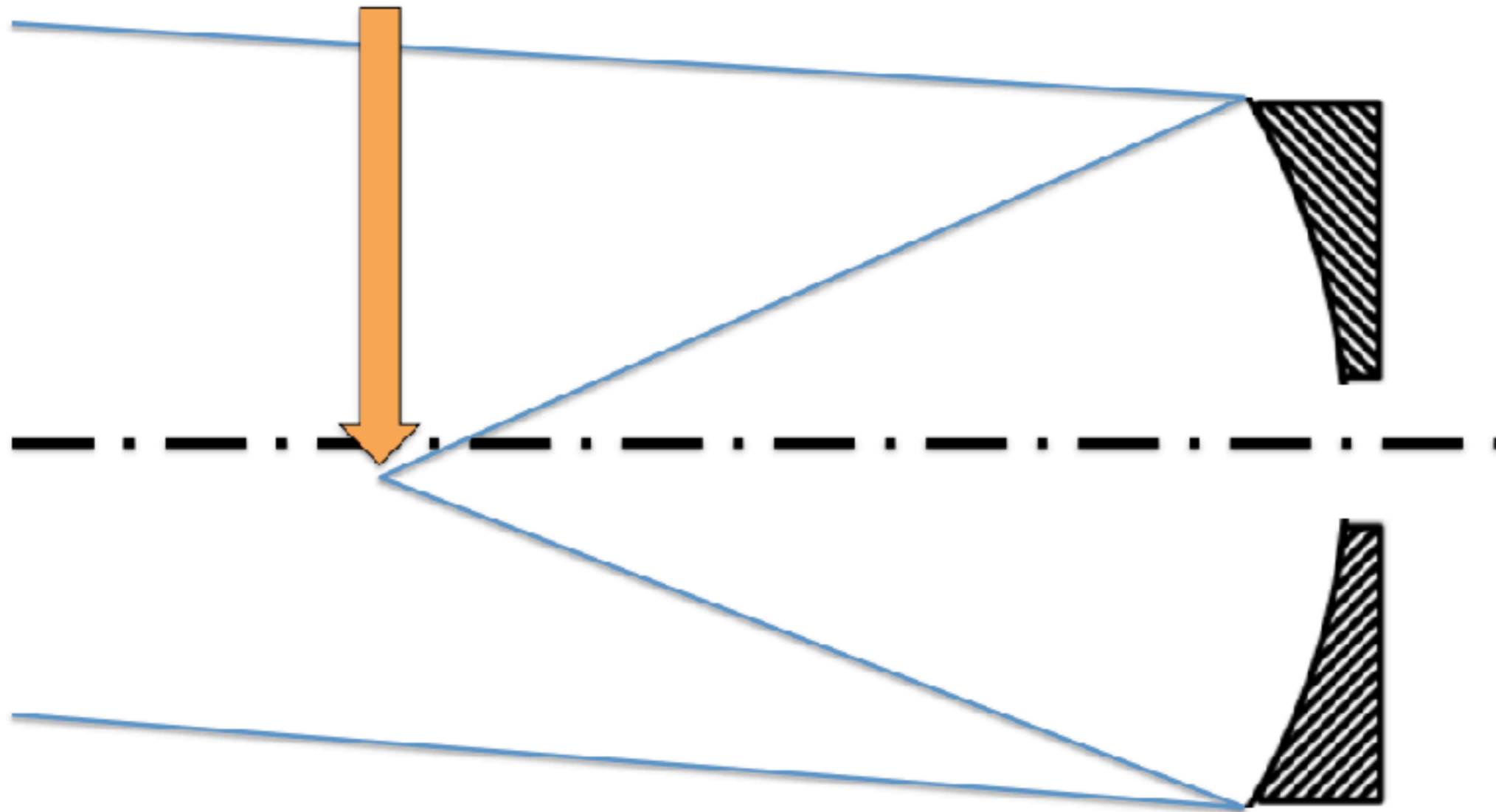

# Come sono fatti i telescopi (ottici)?

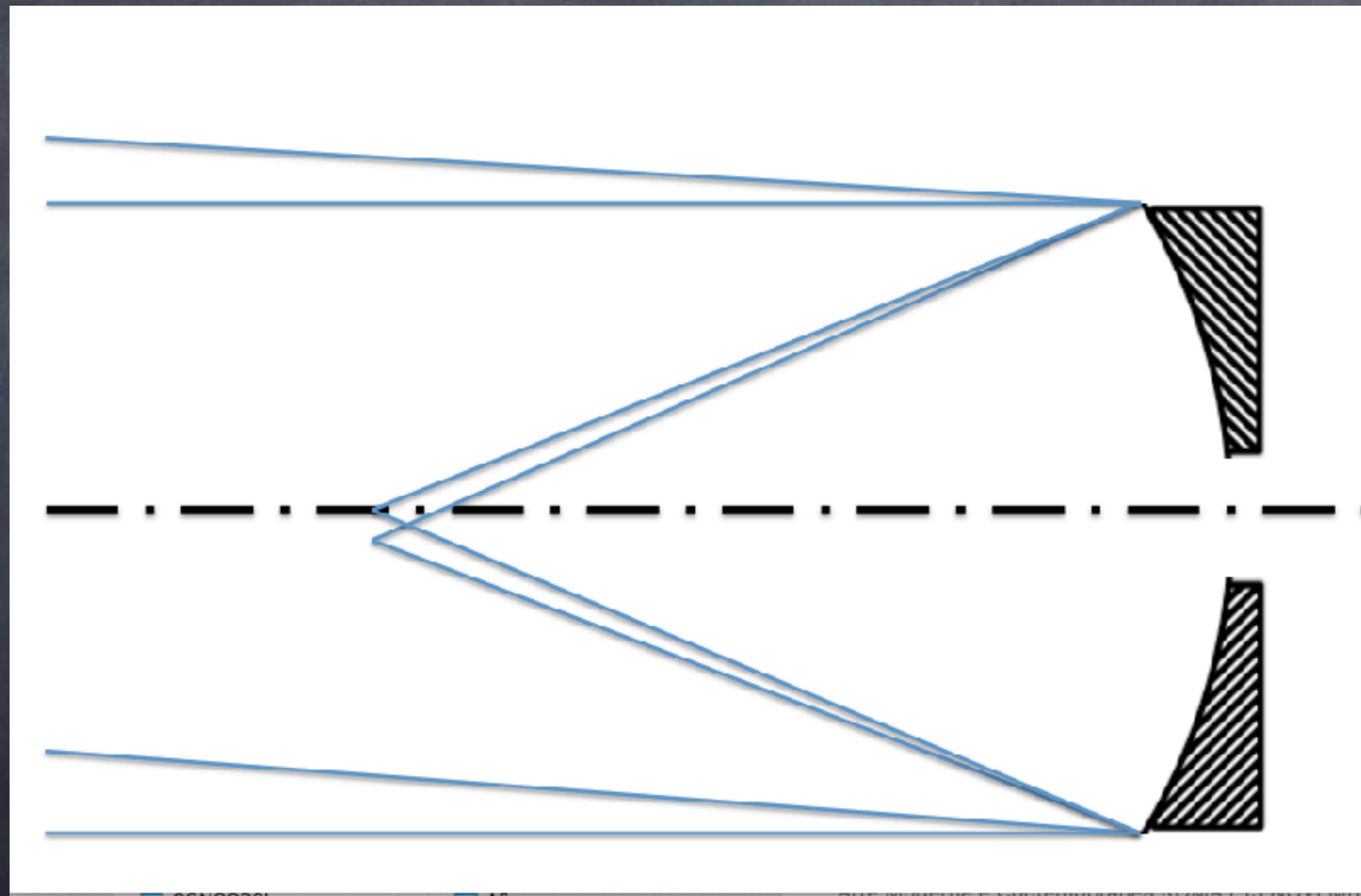



Come sono fatti i telescopi (ottici)?

The primary mirror focal plane

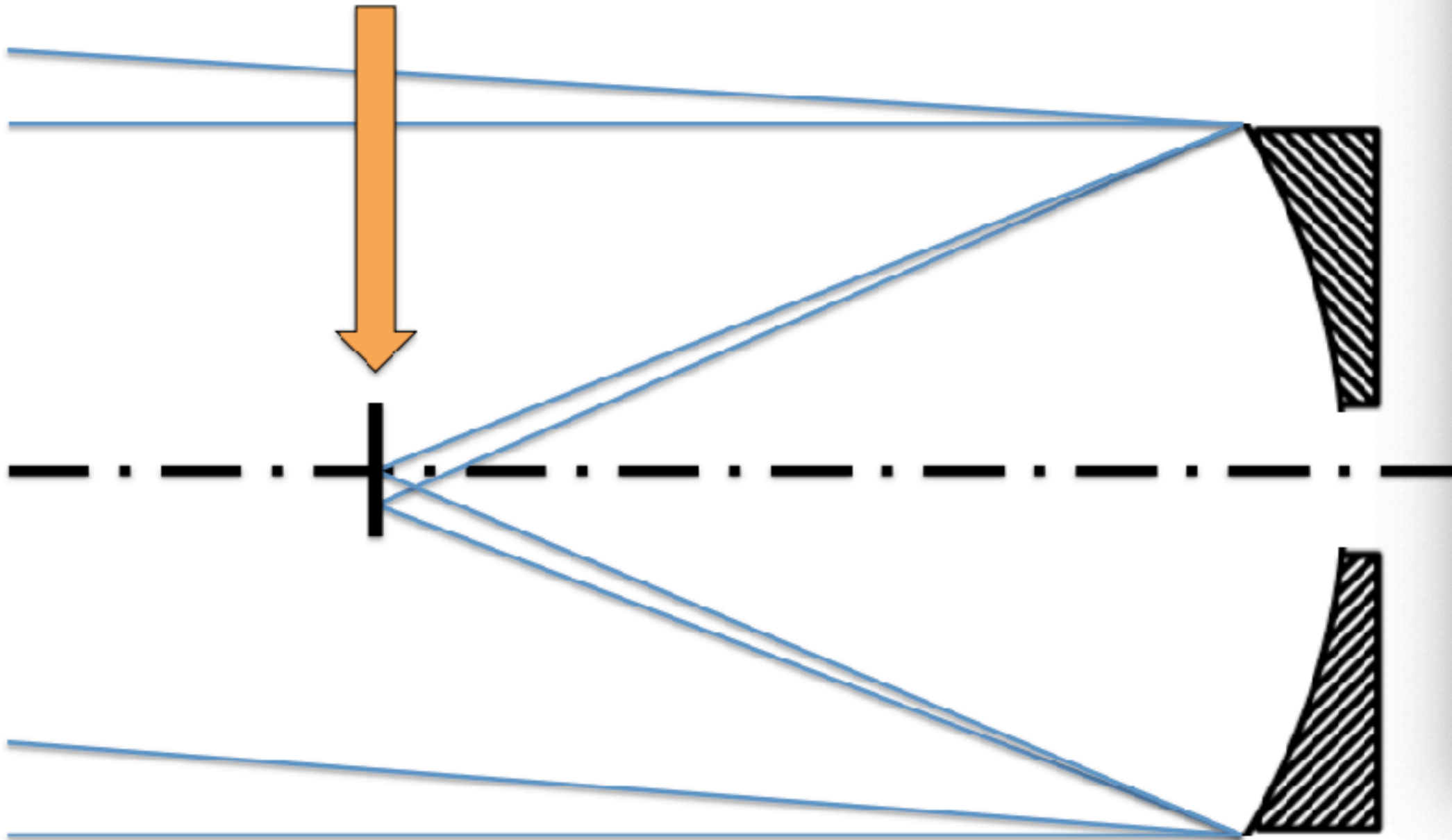

Come sono fatti i telescopi (ottici)?

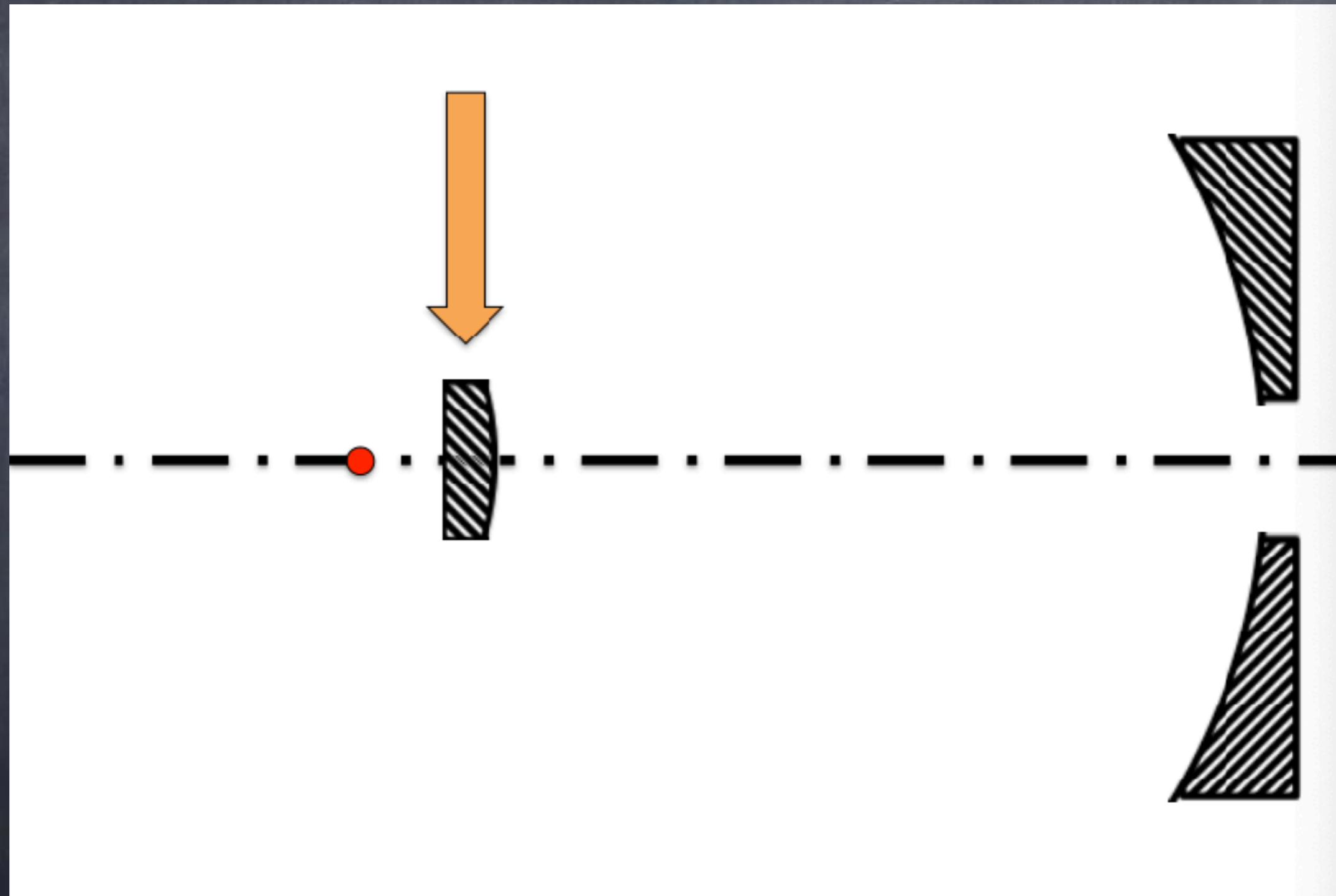

Come sono fatti i telescopi (ottici)?

But instead reach what is called the Cassegrain foci

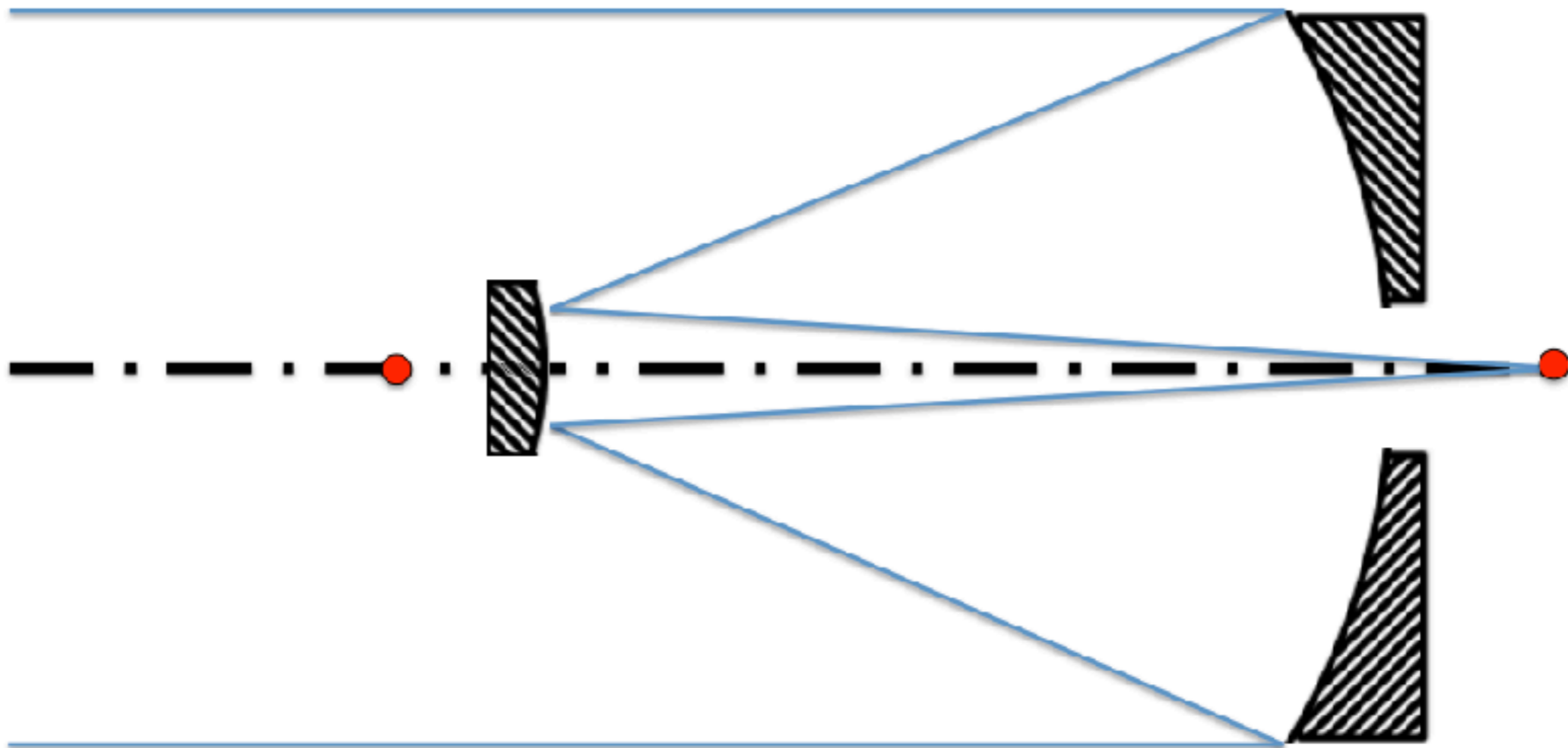

Come sono fatti i telescopi (ottici)?

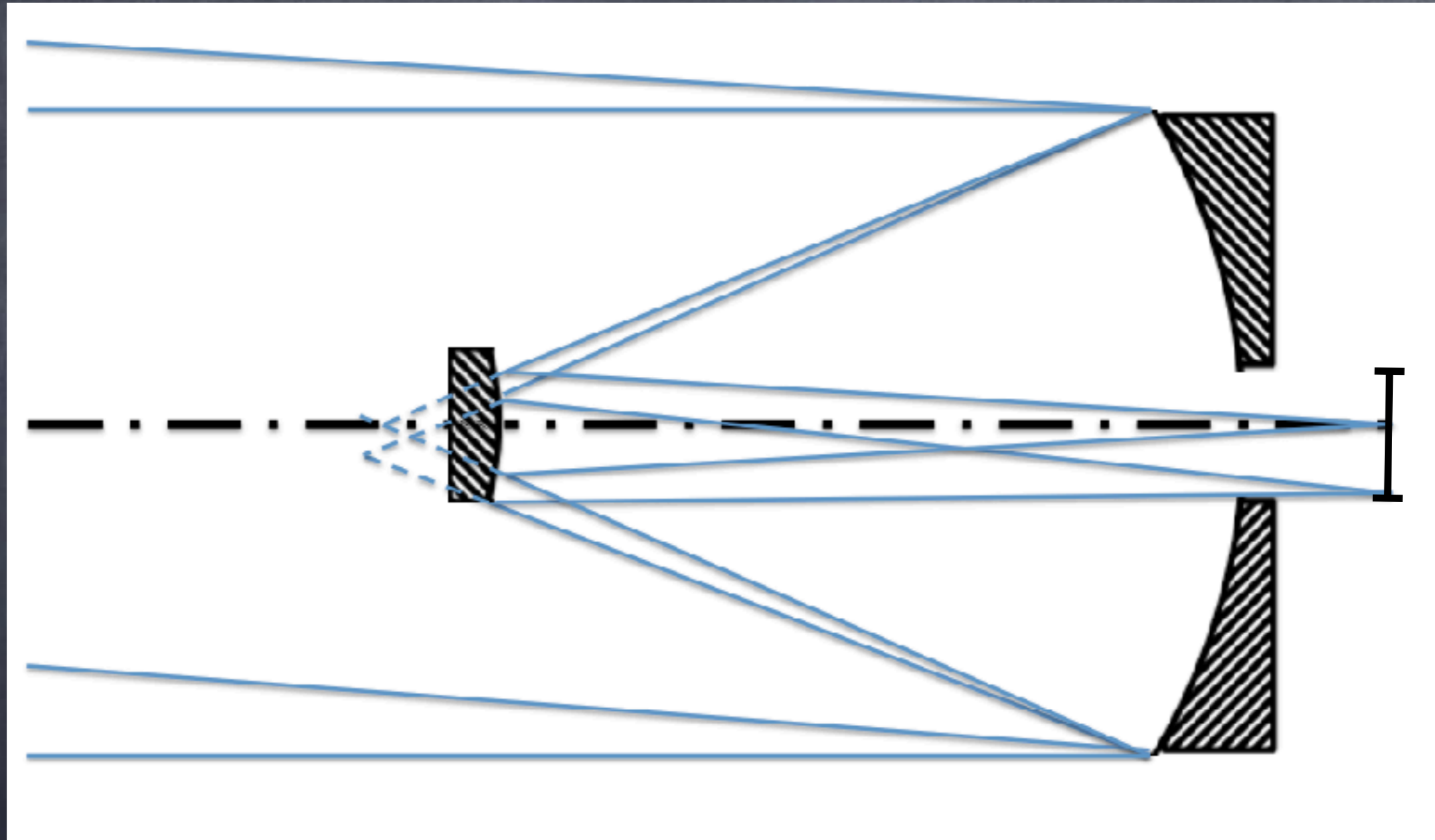

Come sono fatti i telescopi (ottici)?

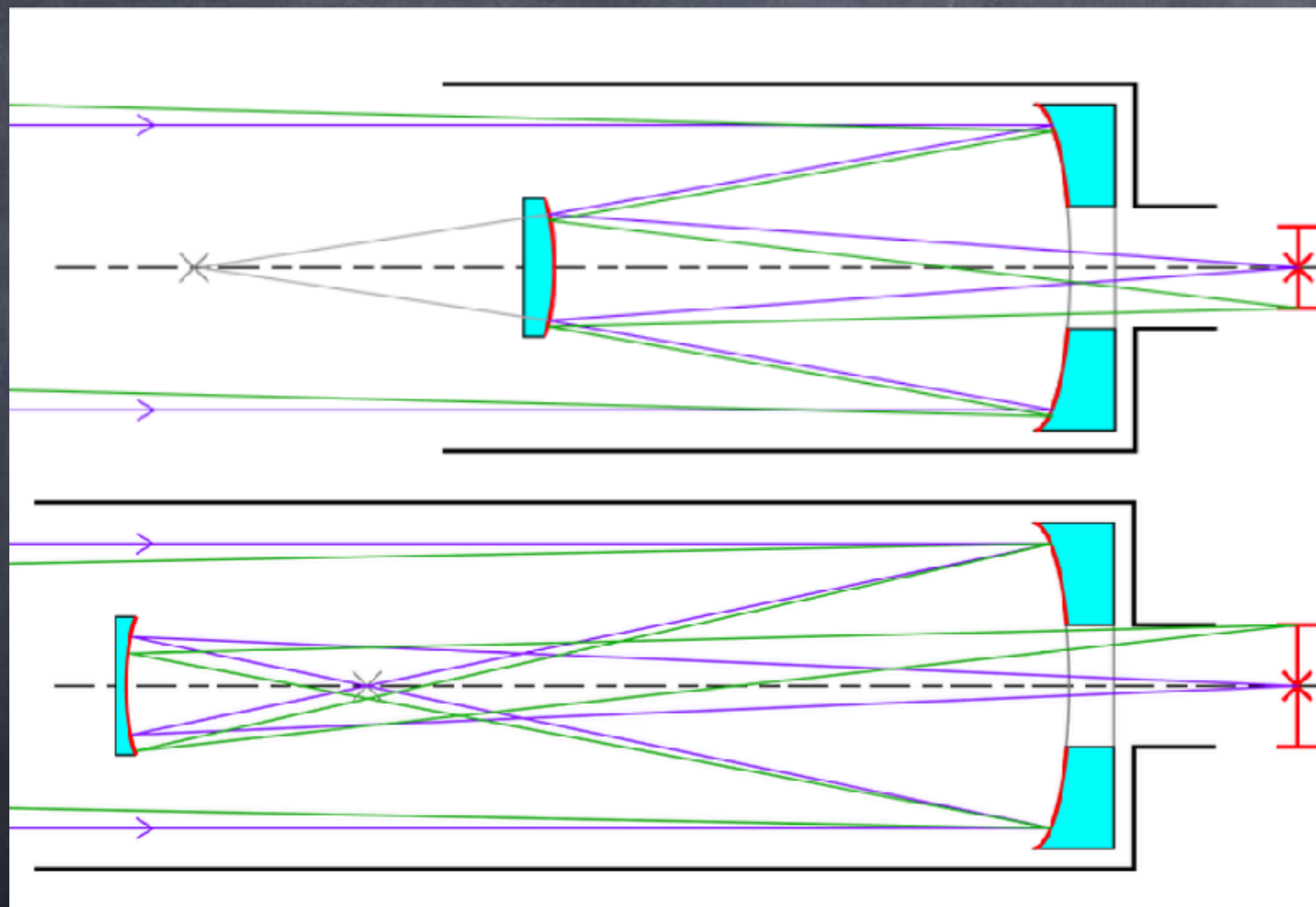

# Come sono fatti i telescopi (ottici)?

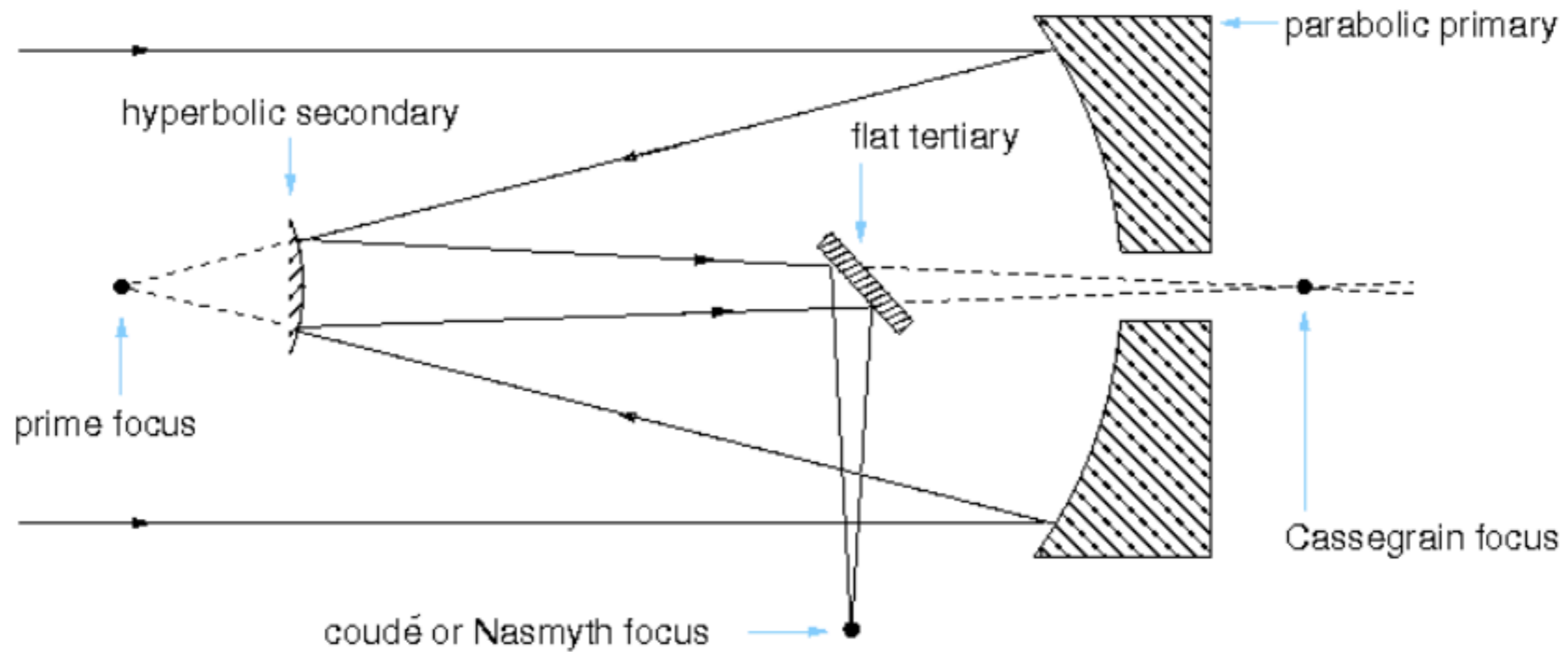

Come sono fatti i telescopi (ottici)?

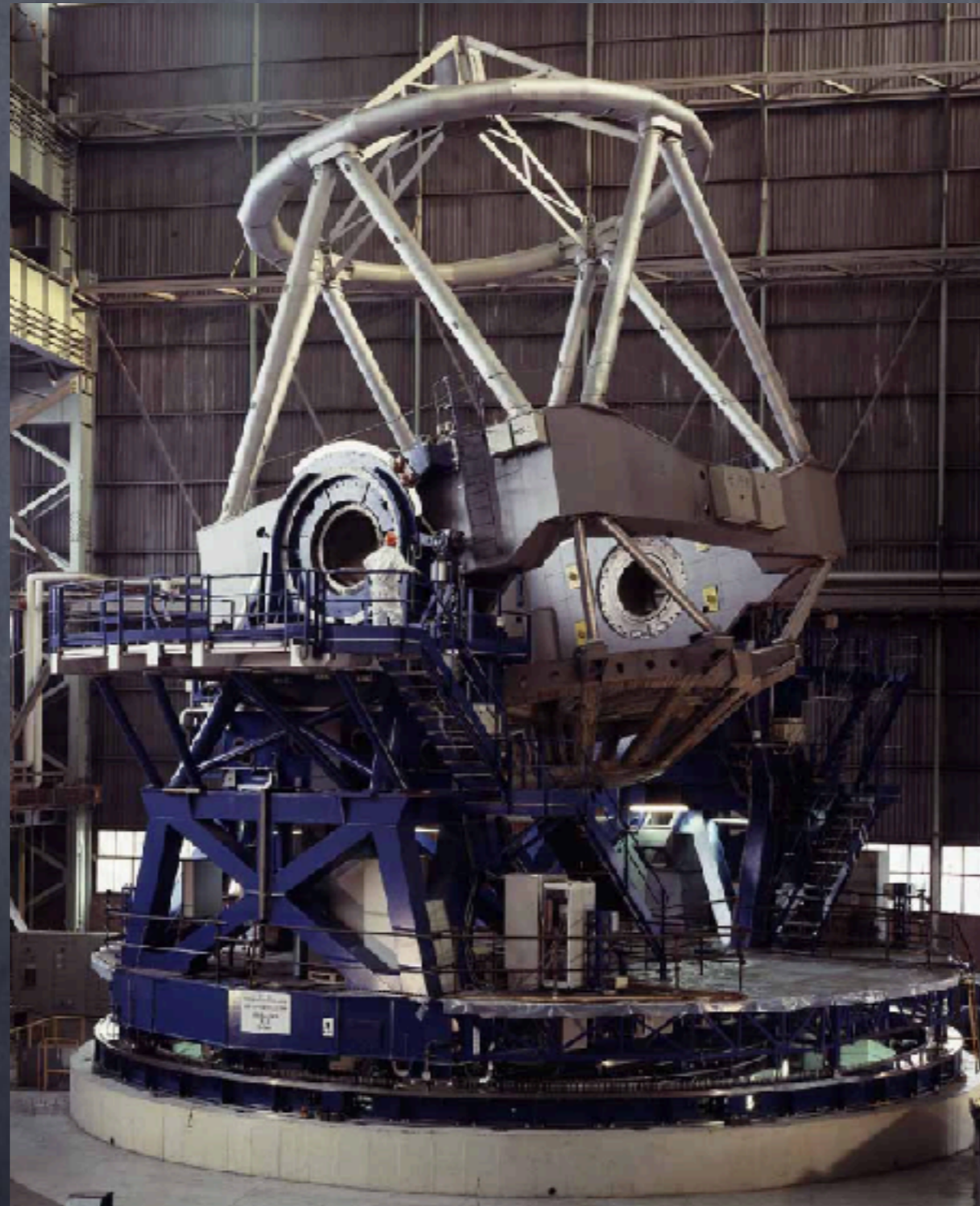

Come sono fatti i telescopi (ottici)?

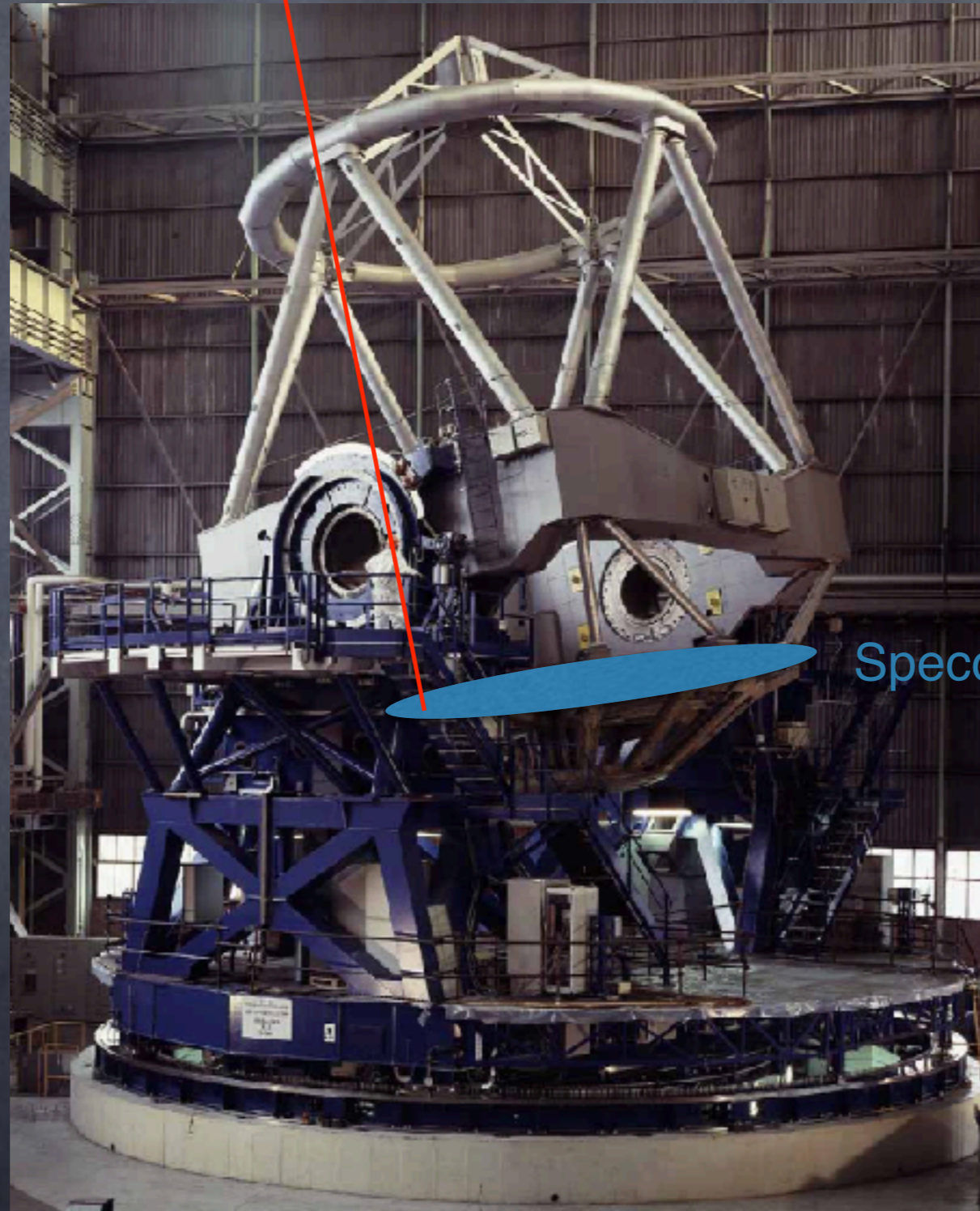

Specchio Primario



Come sono fatti i telescopi (ottici)?

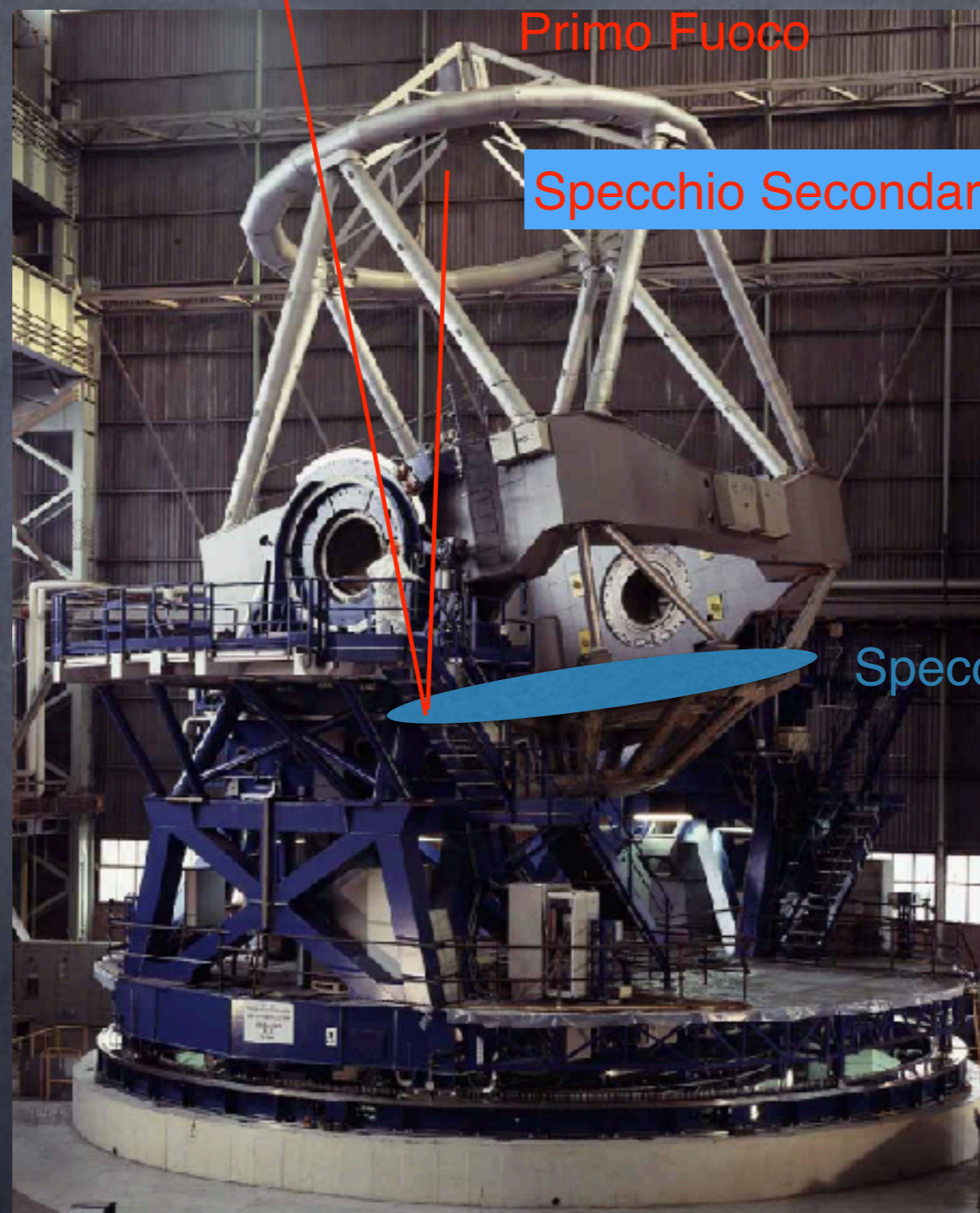

Primo Fuoco

Specchio Secondario

Specchio Primario

Come sono fatti i telescopi (ottici)?

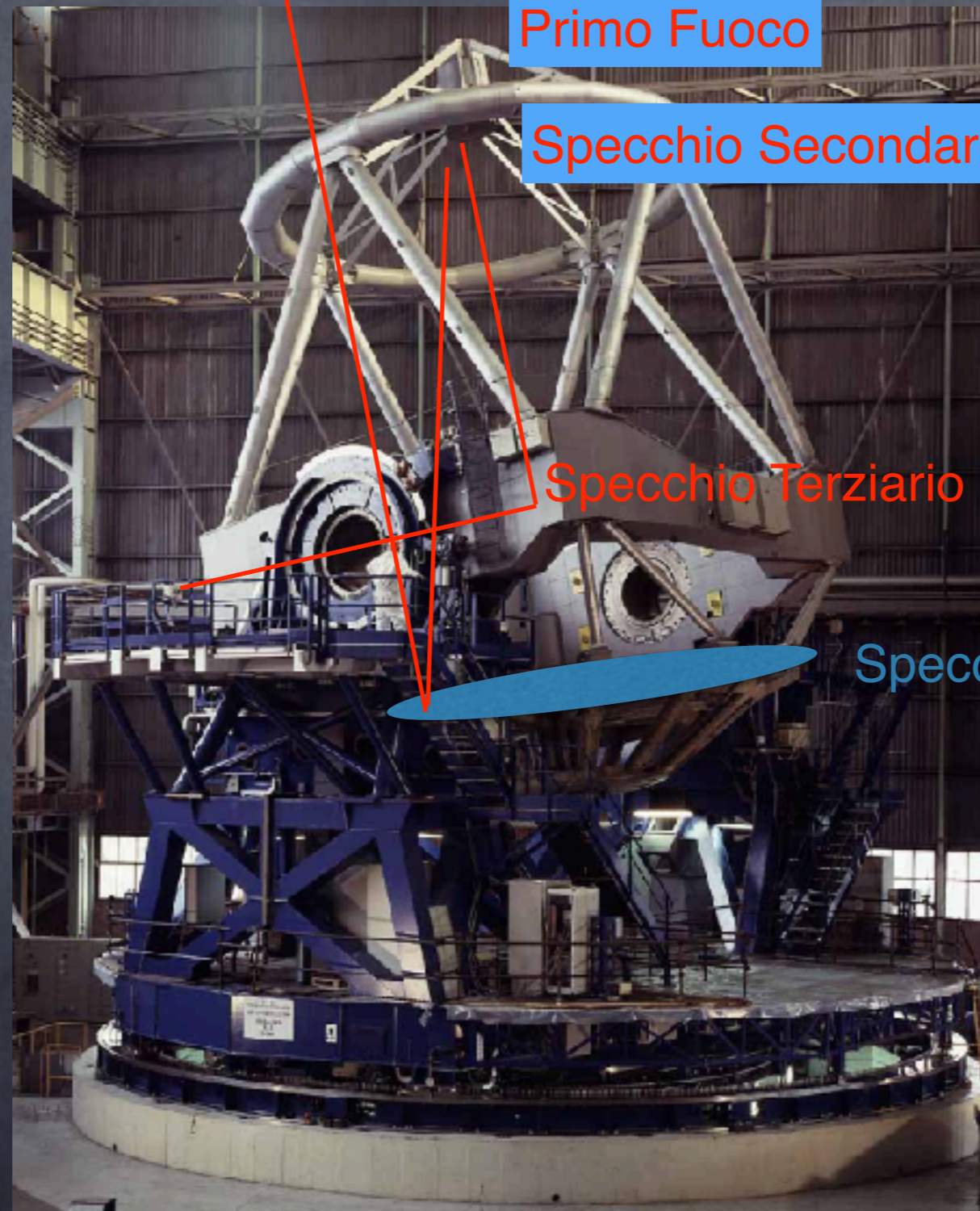

Primo Fuoco

Specchio Secondario

Specchio Terziario

Specchio Primario

# Come sono fatti i telescopi (ottici)?

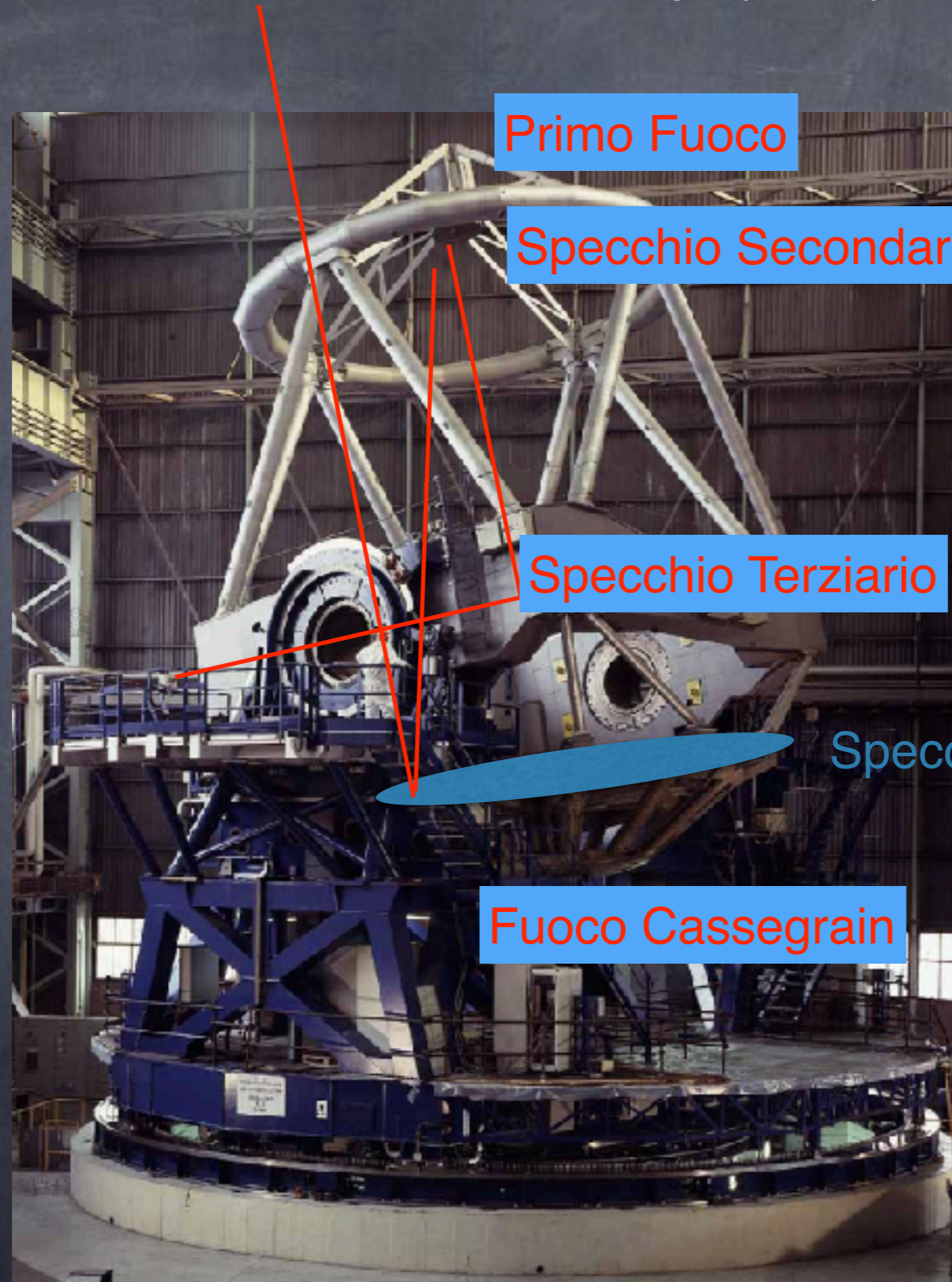

Fuoco Nasmyth

Primo Fuoco

Specchio Secondario

Specchio Terziario

Specchio Primario

Fuoco Cassegrain

Come sono fatti i telescopi (ottici)?

Primo Fuoco

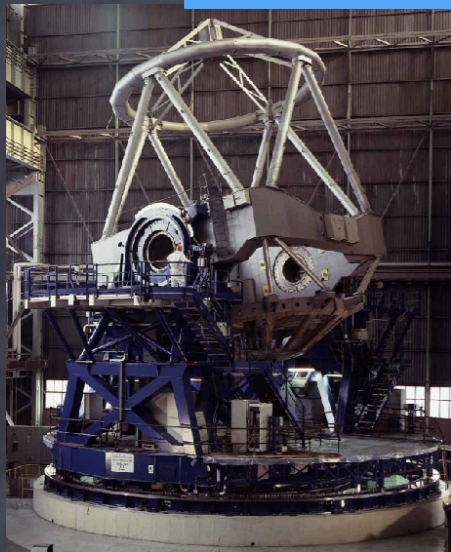

# Come sono fatti i telescopi (ottici)?

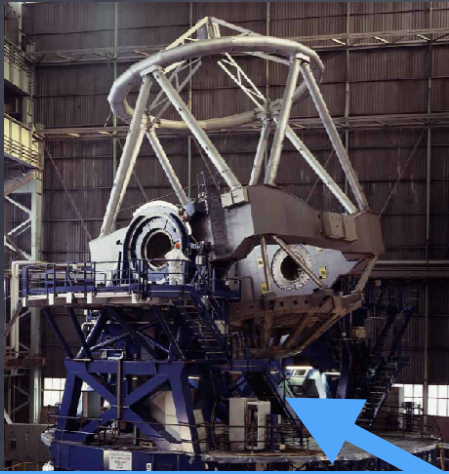

Fuoco Cassegrain



# Come sono fatti i telescopi (ottici)?



Fuoco Nasmyti

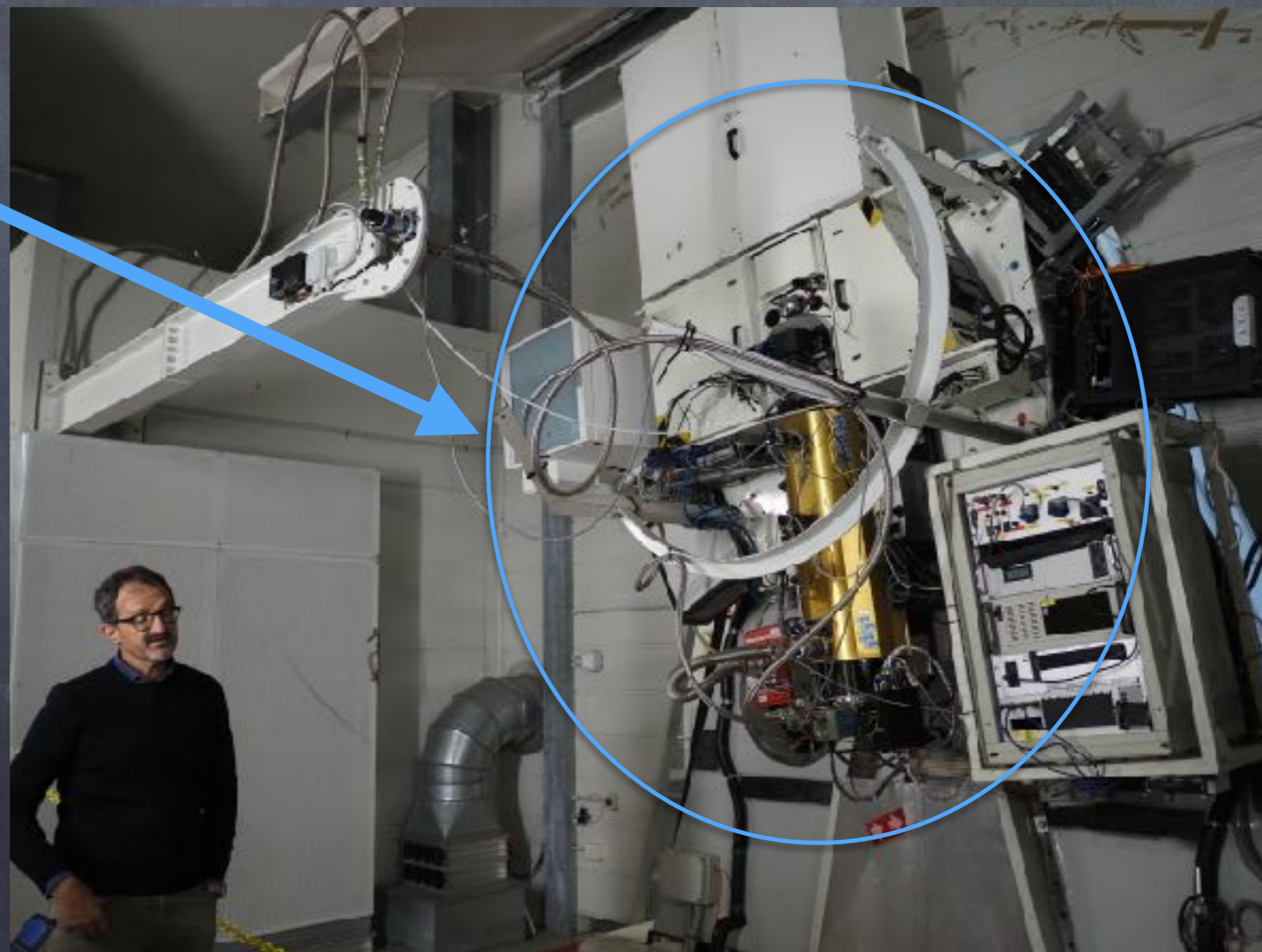

## Come si muovono i telescopi (ottici)?

2 Assi tra loro perpendicolari

- uno perpendicolare al terreno (azimut)
- uno parallelo all'orizzonte (altezza)

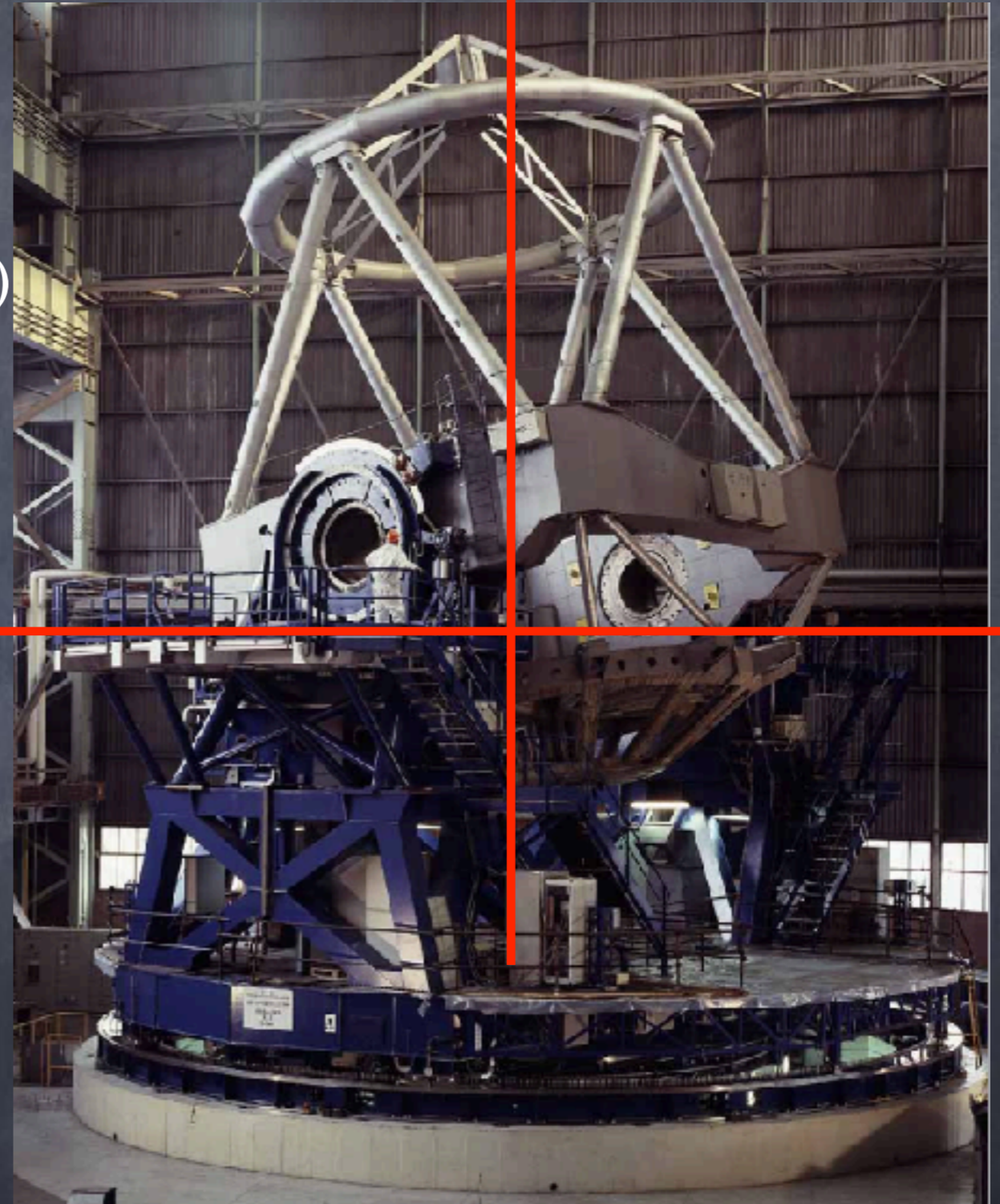

## Come sono fatti i telescopi (ottici)?

D=1.22m the Asiago-Pennar telescope

D=1.82m the Asiago-Ekar telescope

D=3.58m the TNG, Telescopio Nazionale Galileo

D=8.2m one of the VLT, Very Large Telescope

D=8.4m one of the mirror of the LBT, Large Binocular Telescope

D=30m the TMT, Thirty Mirror Telescope

D=39m the E-ELT, European Extremely Large Telescope





# Come sono fatti i telescopi (ottici)?

This light is actually collected from the telescope...

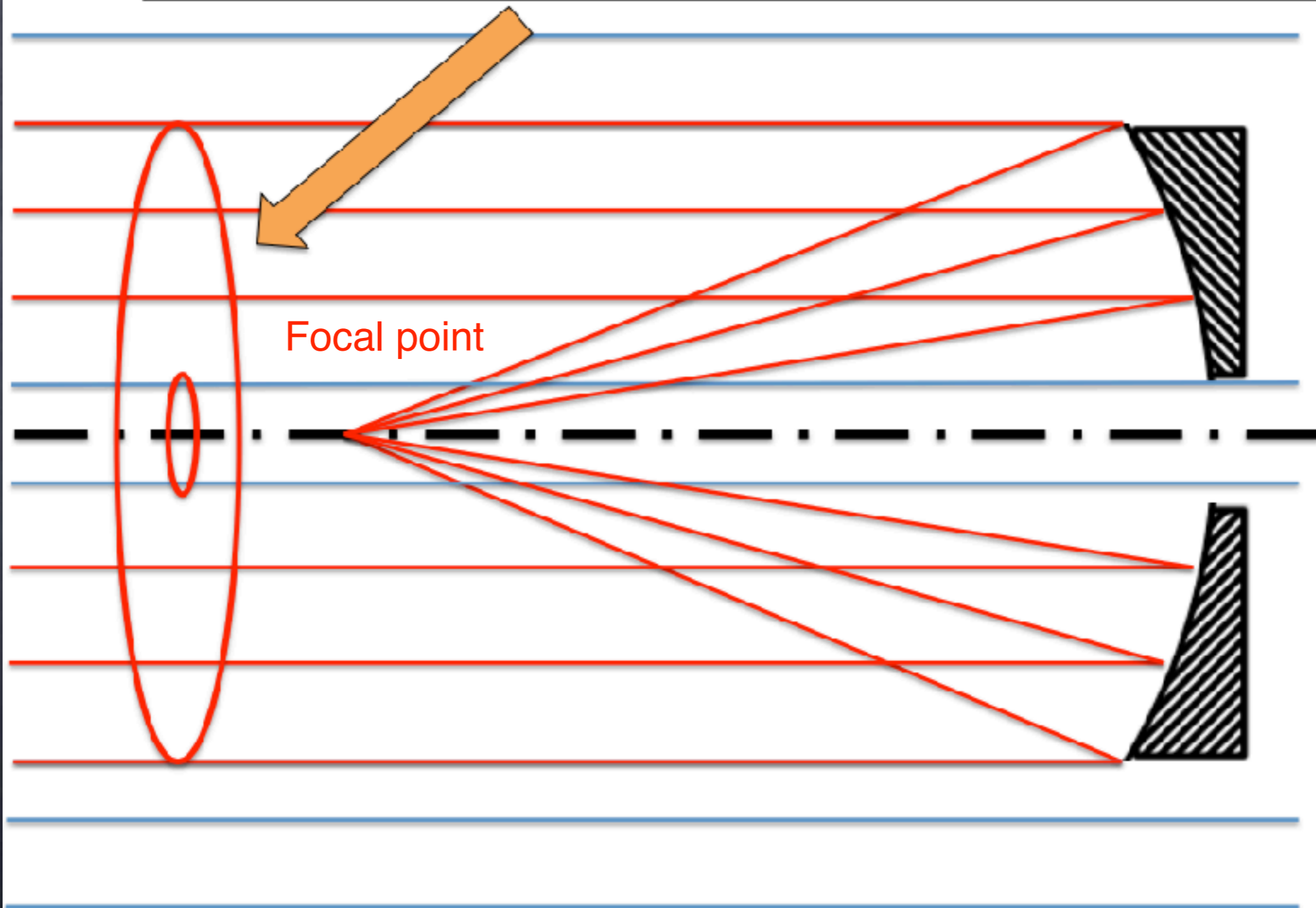

For a light-ray, a telescope is an aperture donut-shaped

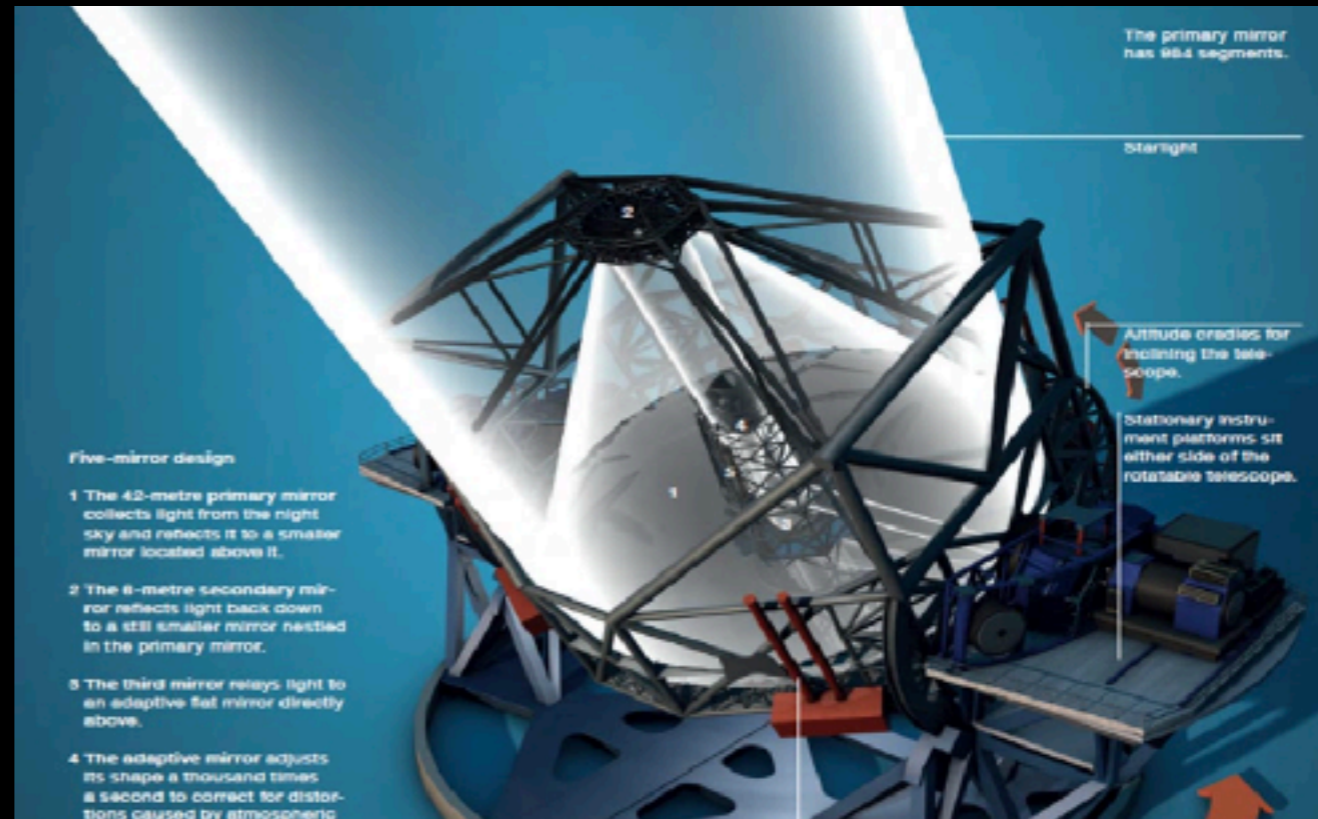

For a light-ray, a telescope is an aperture donut-shaped

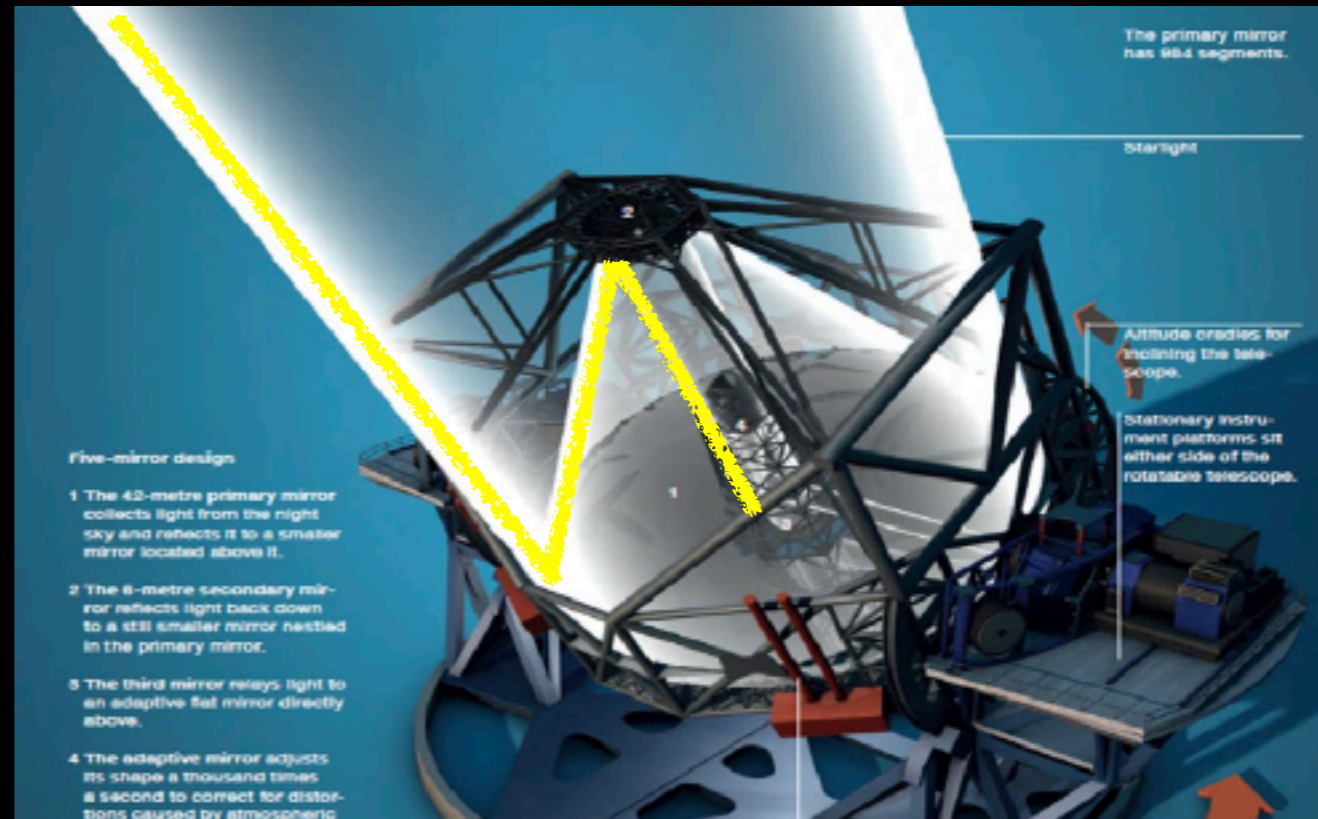

For a light-ray, a telescope is an aperture donut-shaped

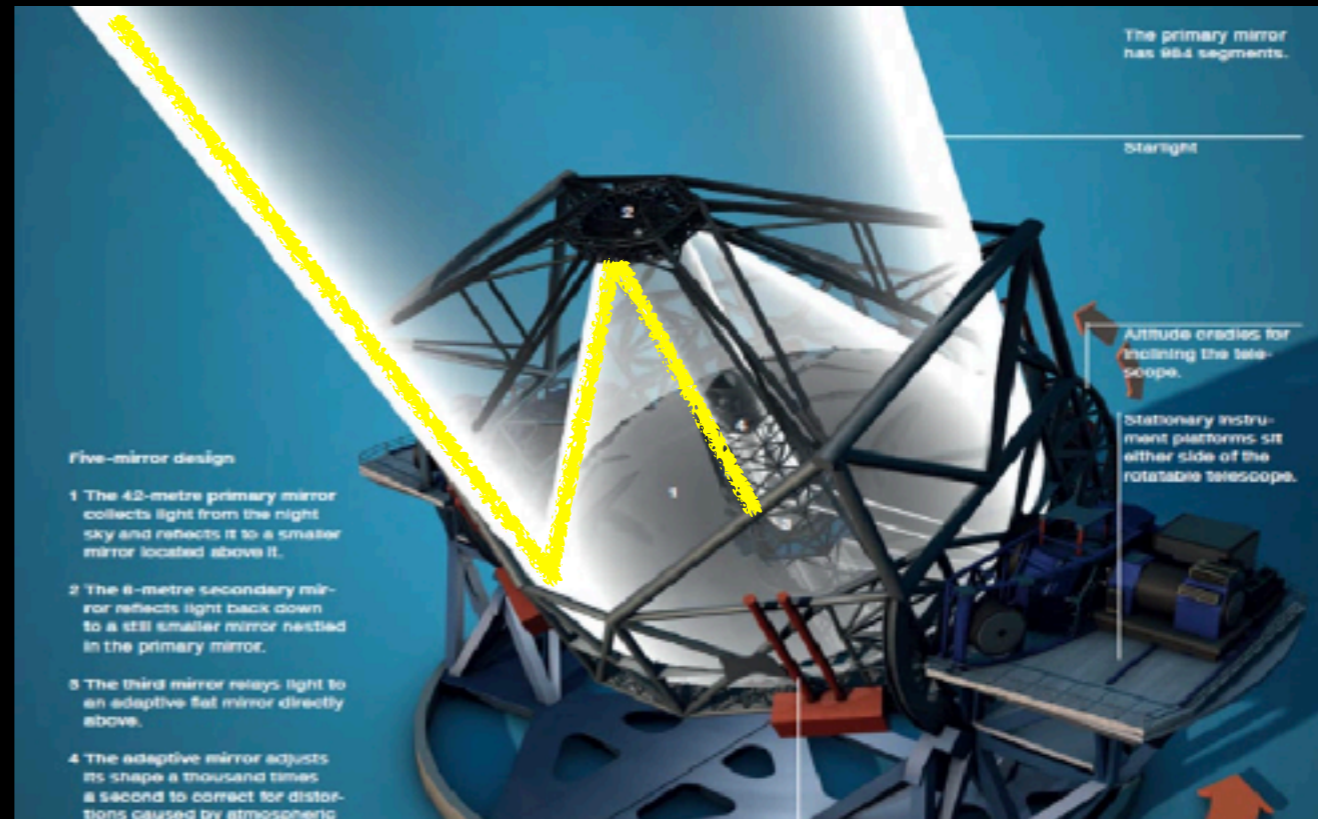
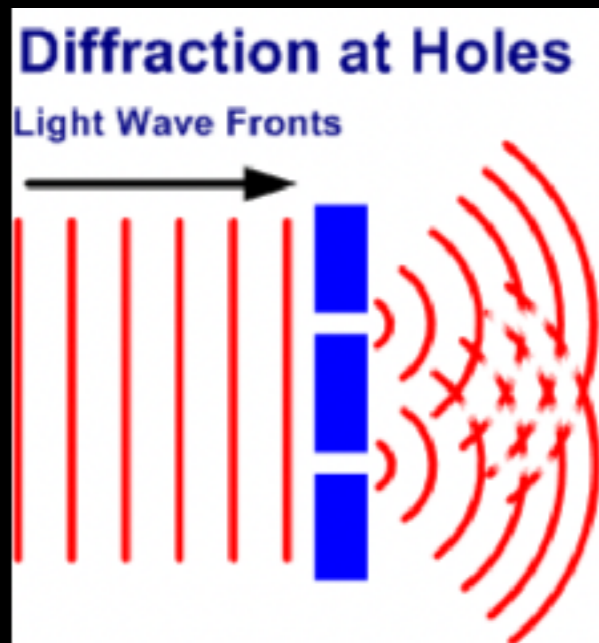

For a light-ray, a telescope is an aperture donut-shaped

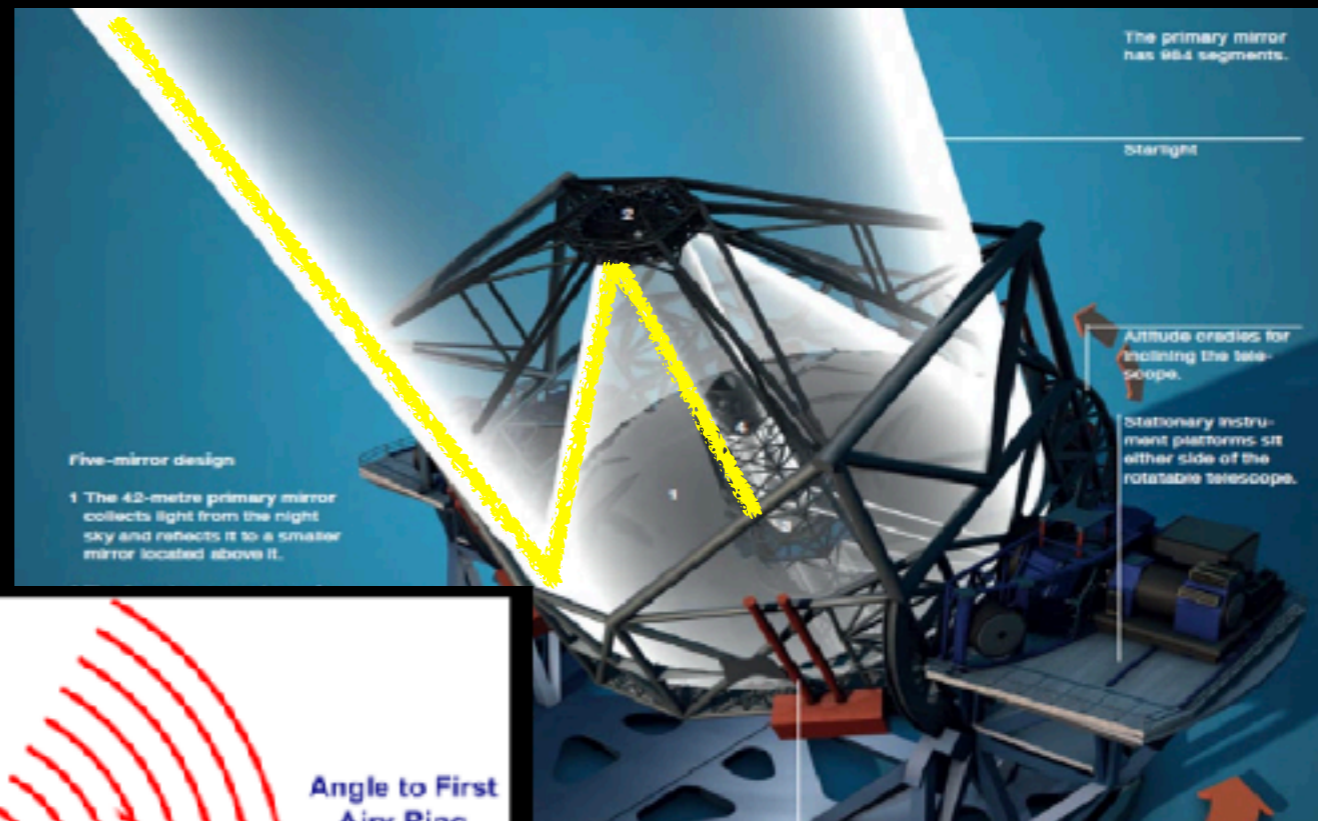
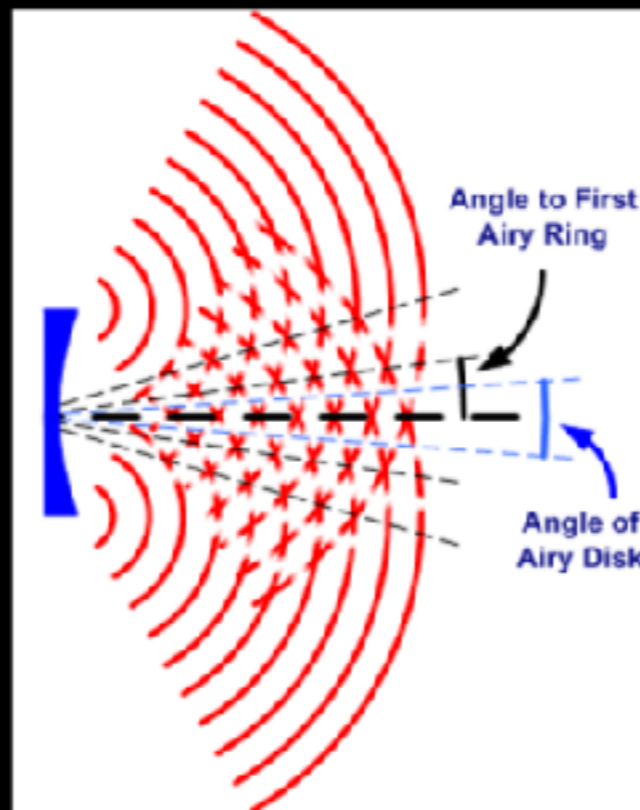
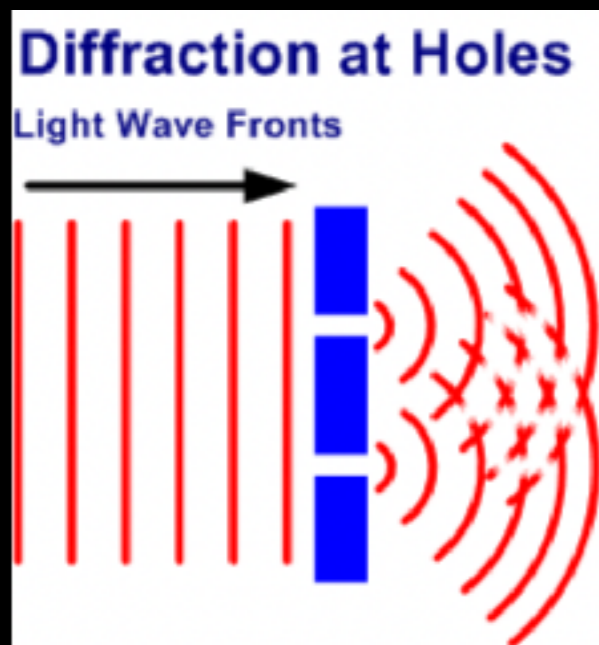

For a light-ray, a telescope is an aperture donut-shaped

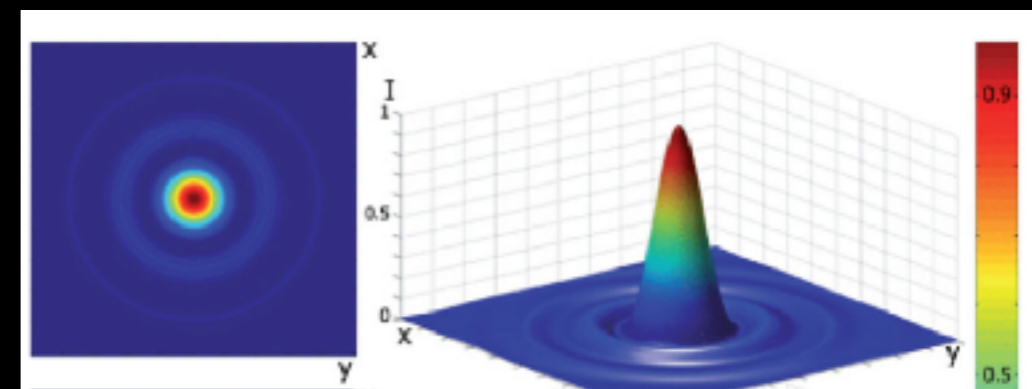
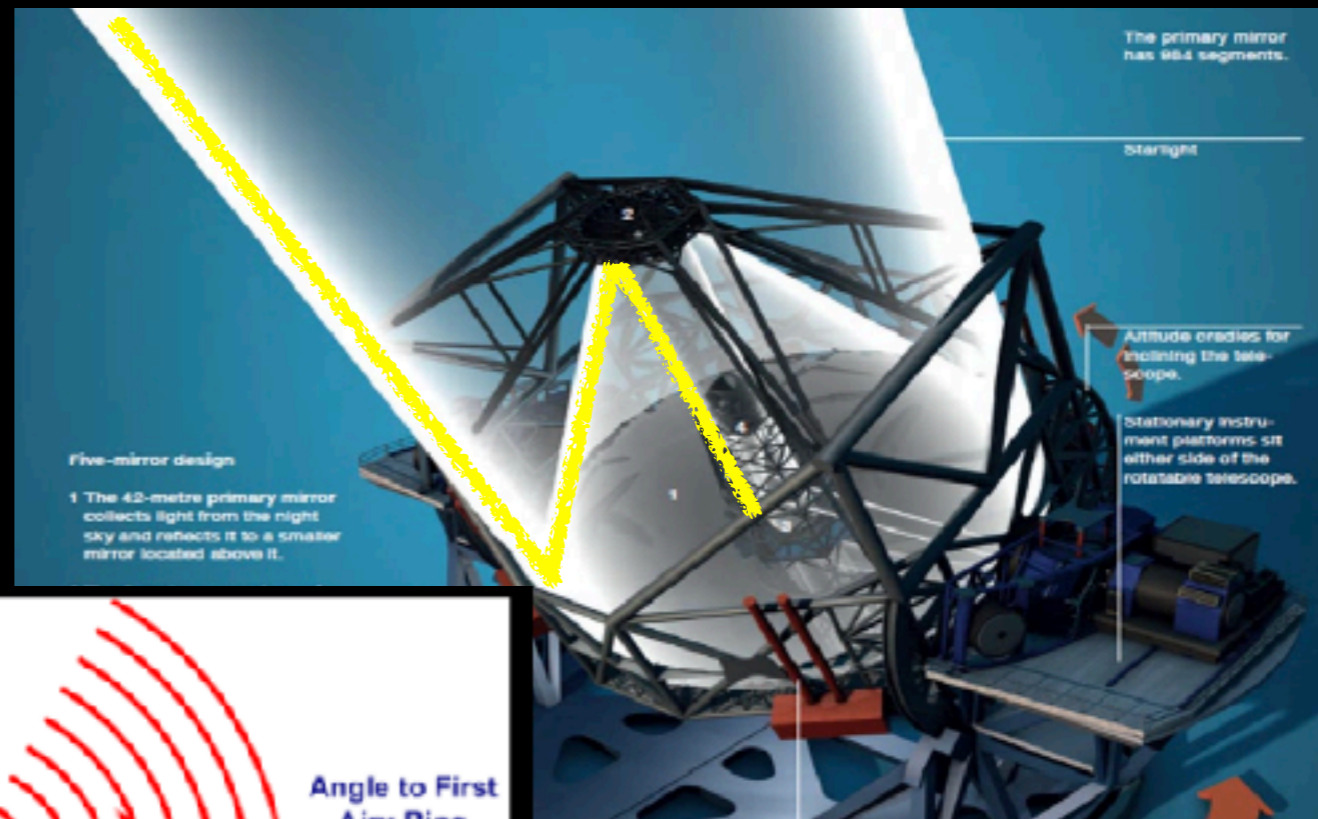
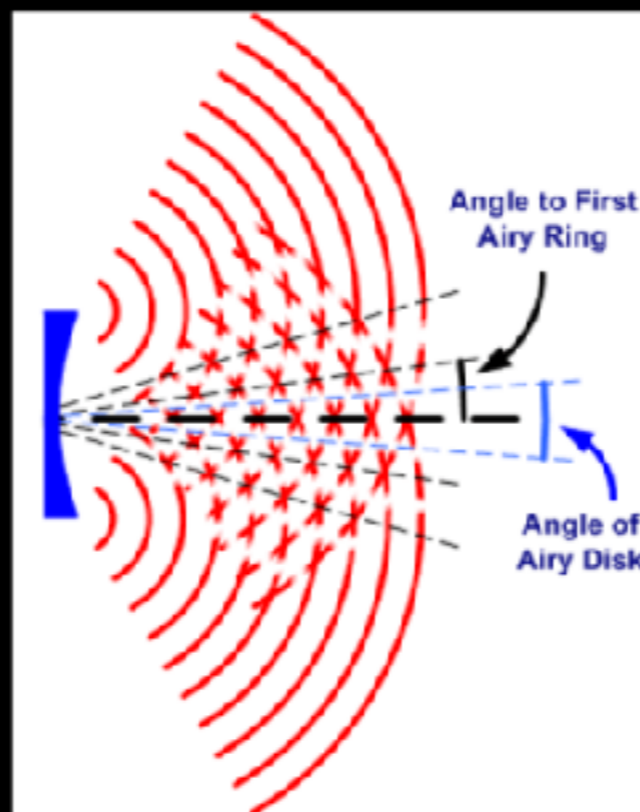
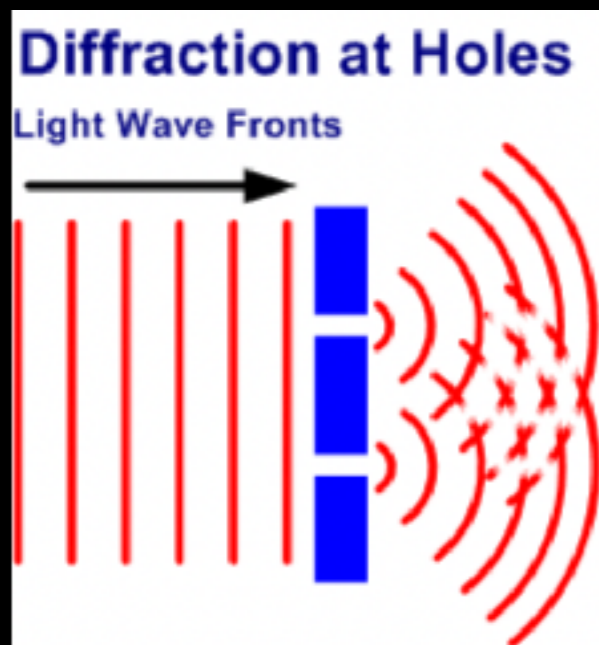

For a light-ray, a telescope is an aperture donut-shaped



Even for a perfect telescope, a star is not a point but a diffraction shape: Airy disk.

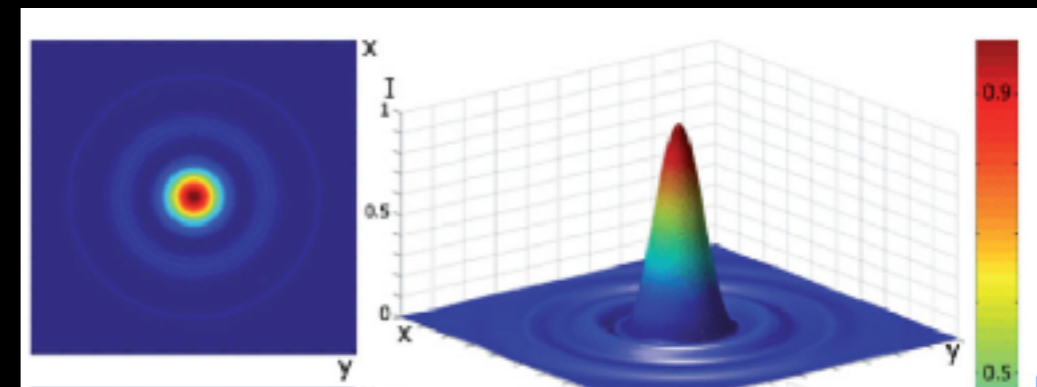
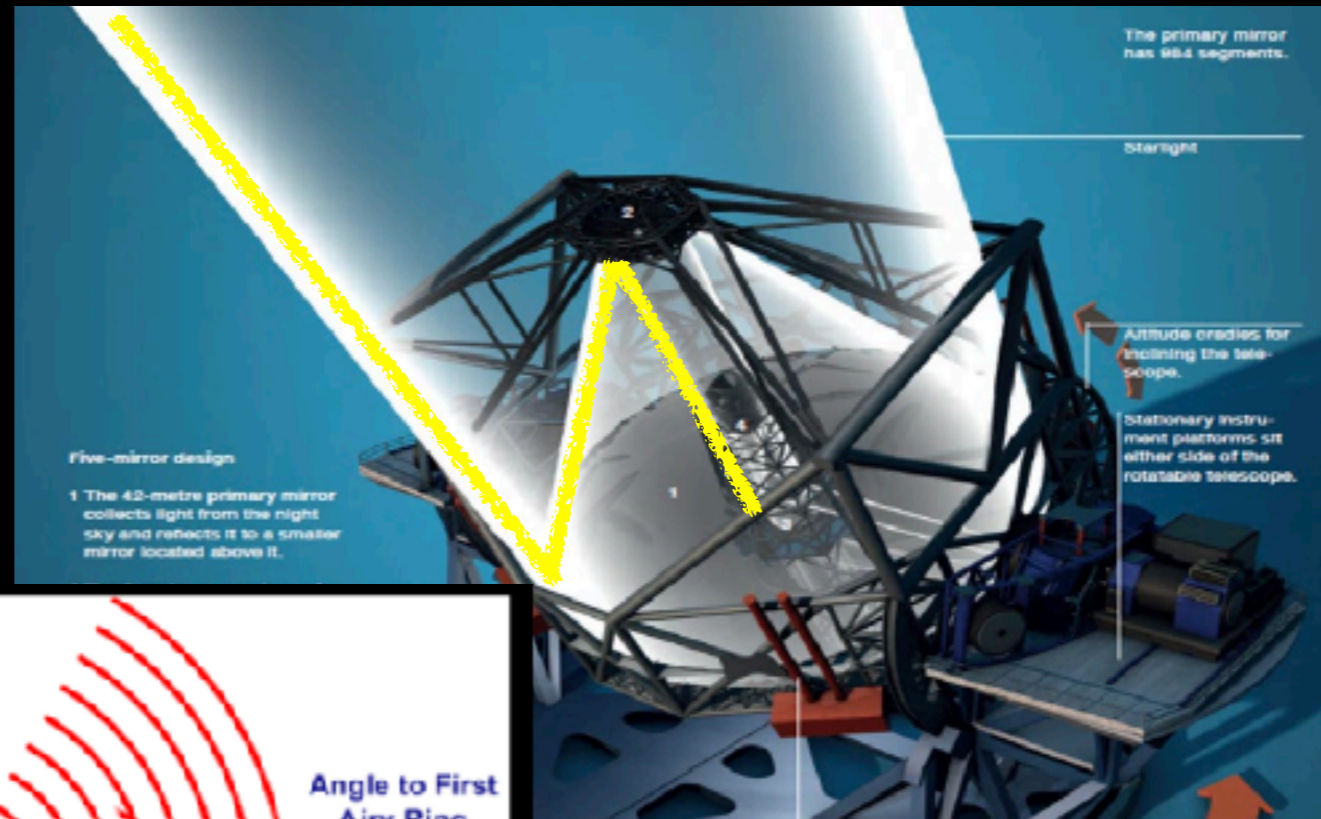
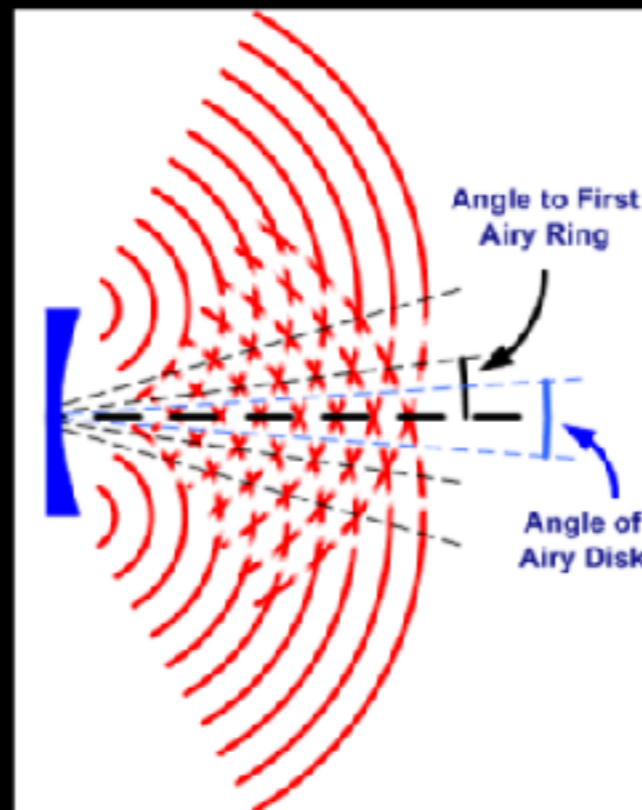

The width of the peak is the Point Spread Function (PSF).

It is the smallest distance between two point-like objects that can be detected.

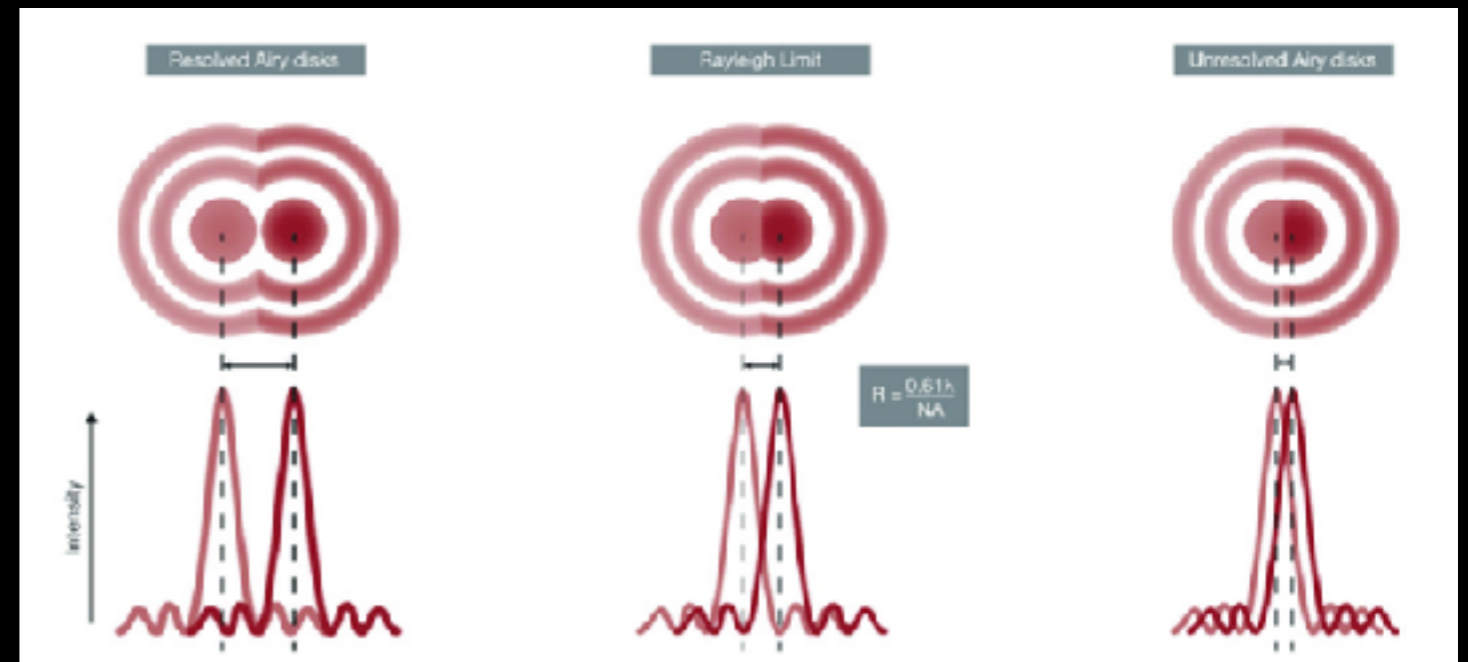
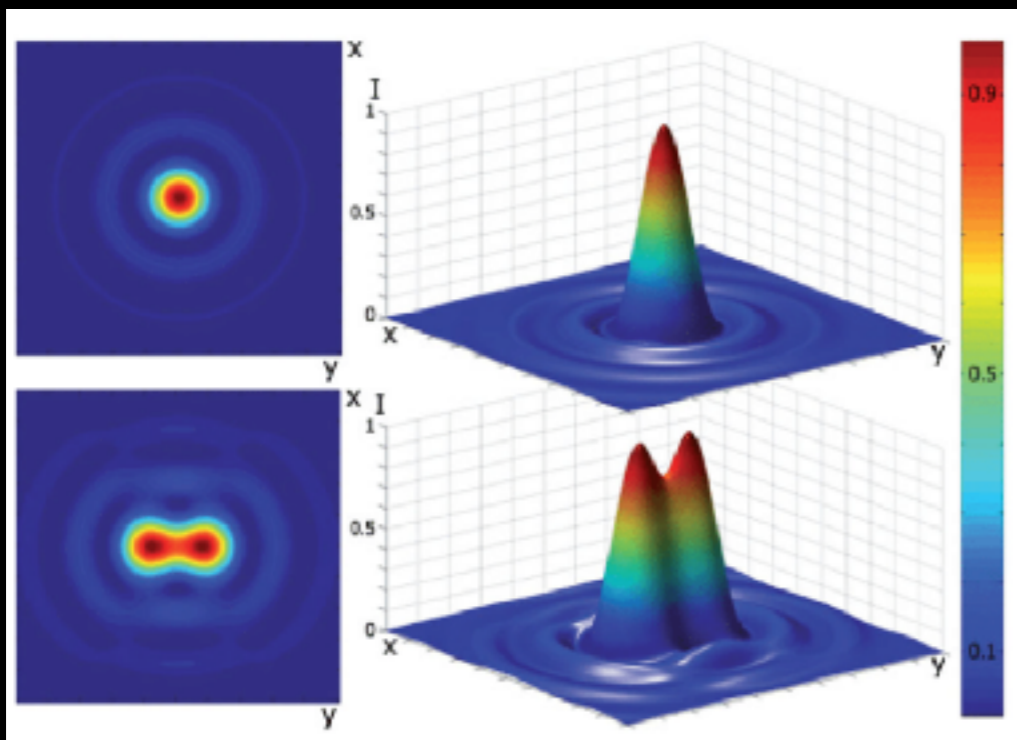



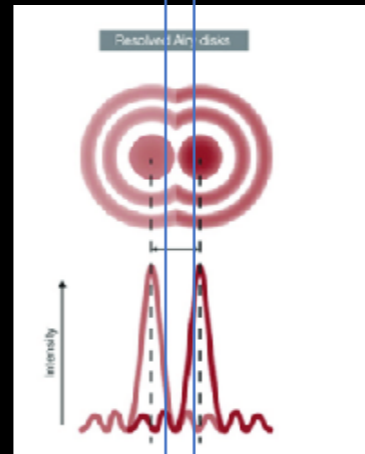
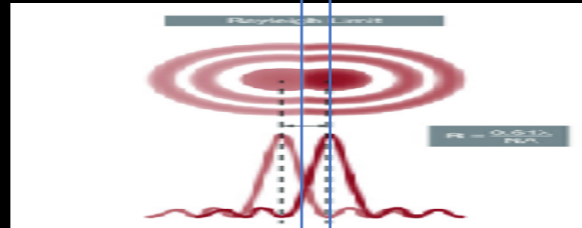
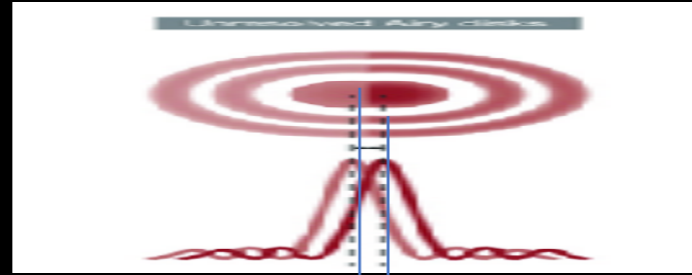
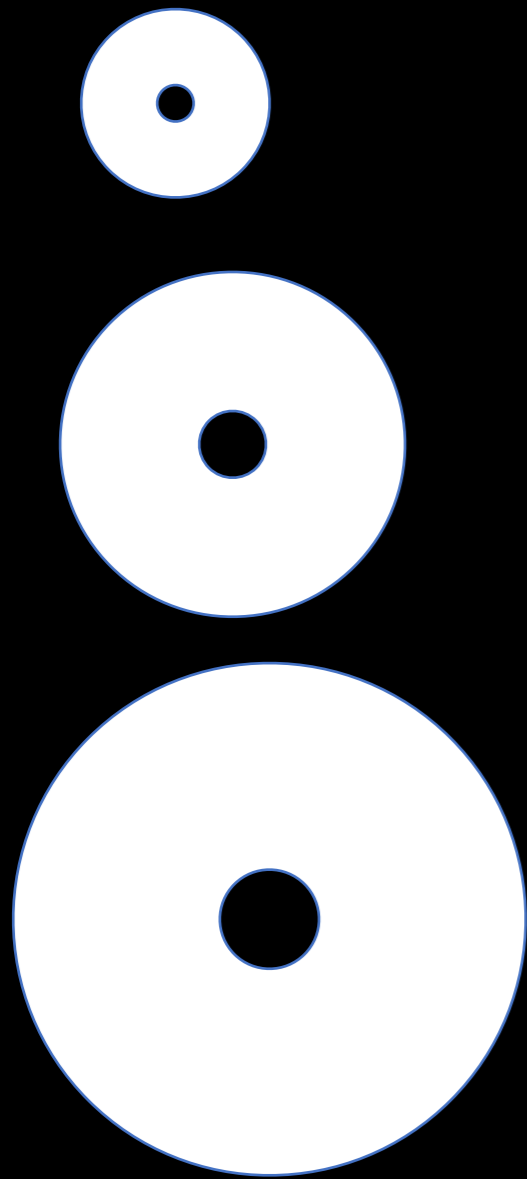

$$\text{FWHM} = 1.029 \frac{\lambda}{D}$$

La PSF (Point Spread Function) tipicamente si misura in *secondi d'arco*.

$$1\text{arcsec} = \frac{\pi}{180 \times 60 \times 60} \simeq 5 \times 10^{-6} \text{ rad}$$

$$\text{FWHM (ideale)}^{(*)} = 1.029 \frac{\lambda}{D} \simeq 10^{-7} \text{ rad} = 0.02 \text{ arcsec}$$

(\*) per un telescopio con  $D=10\text{m}$  e  $\lambda = 1\mu\text{m}$

$$\text{FWHM (JWST)}^{(*)} = 1.029 \frac{\lambda}{D} \simeq 10^{-7} \text{ rad} = 0.06 \text{ arcsec}$$

(\*) per il James Webb Space Telescope con  $D=6.5\text{m}$  e  $\lambda = 2\mu\text{m}$



**Hubble  
(2.5m)**

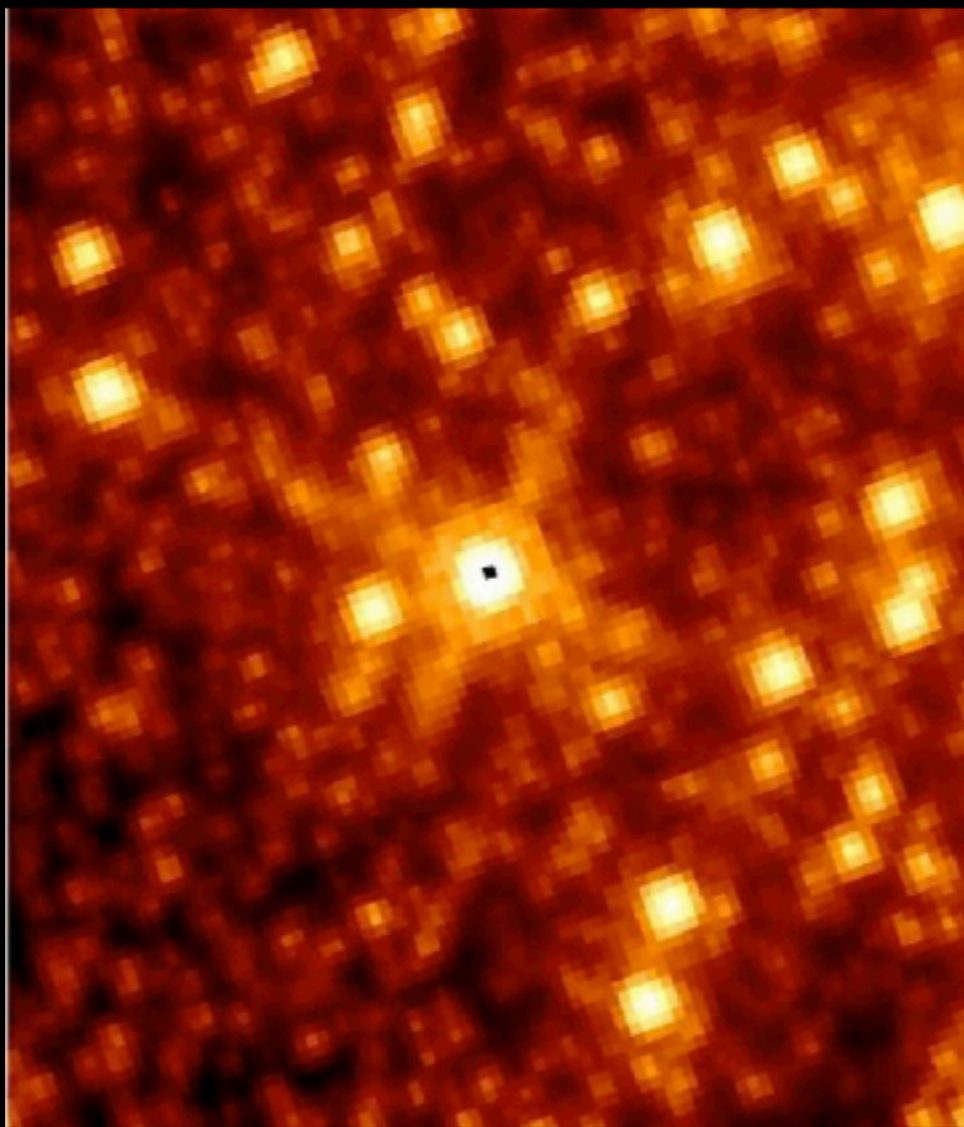

**LBT  
(8.4m)**

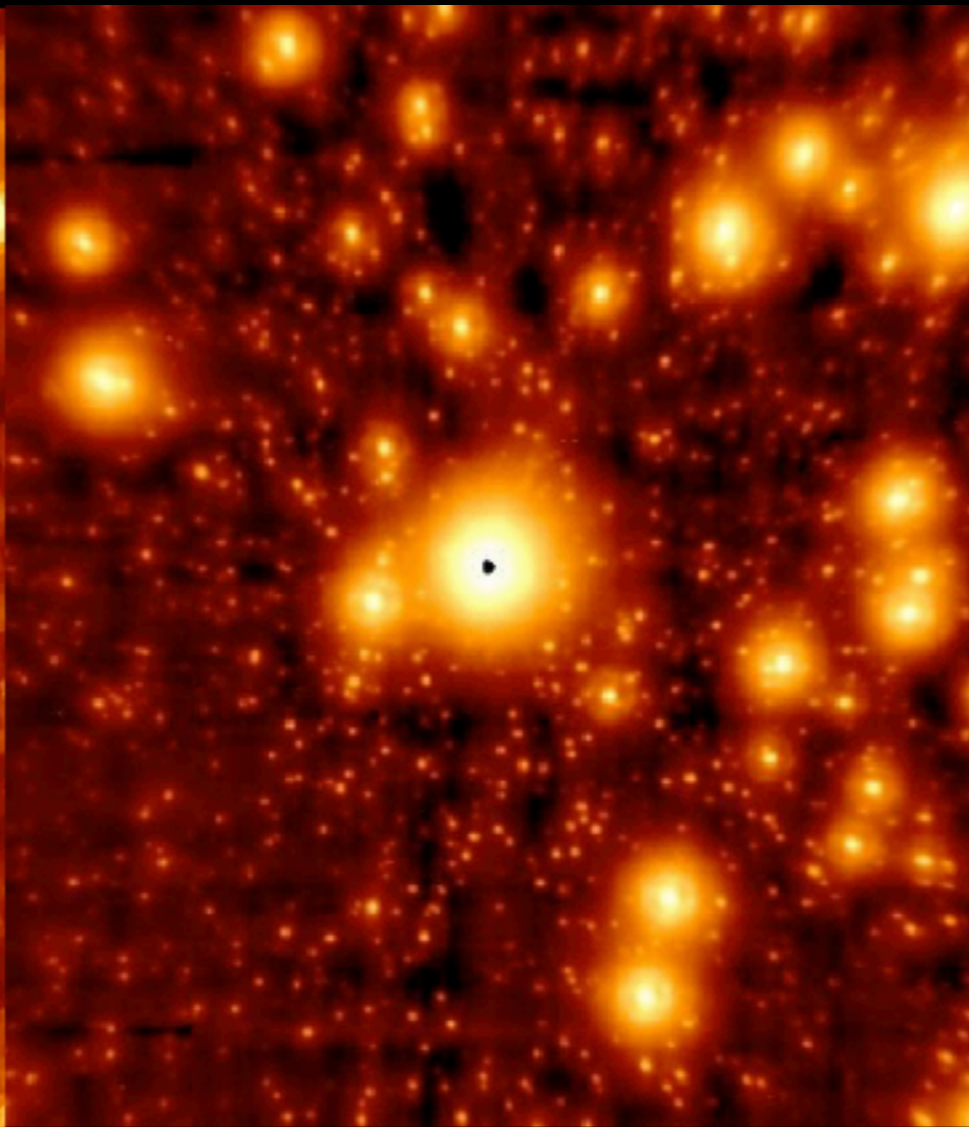

# Why do we need a better resolution?

1) Details matters...

# Why do we need a better resolution?

1) Details matters...

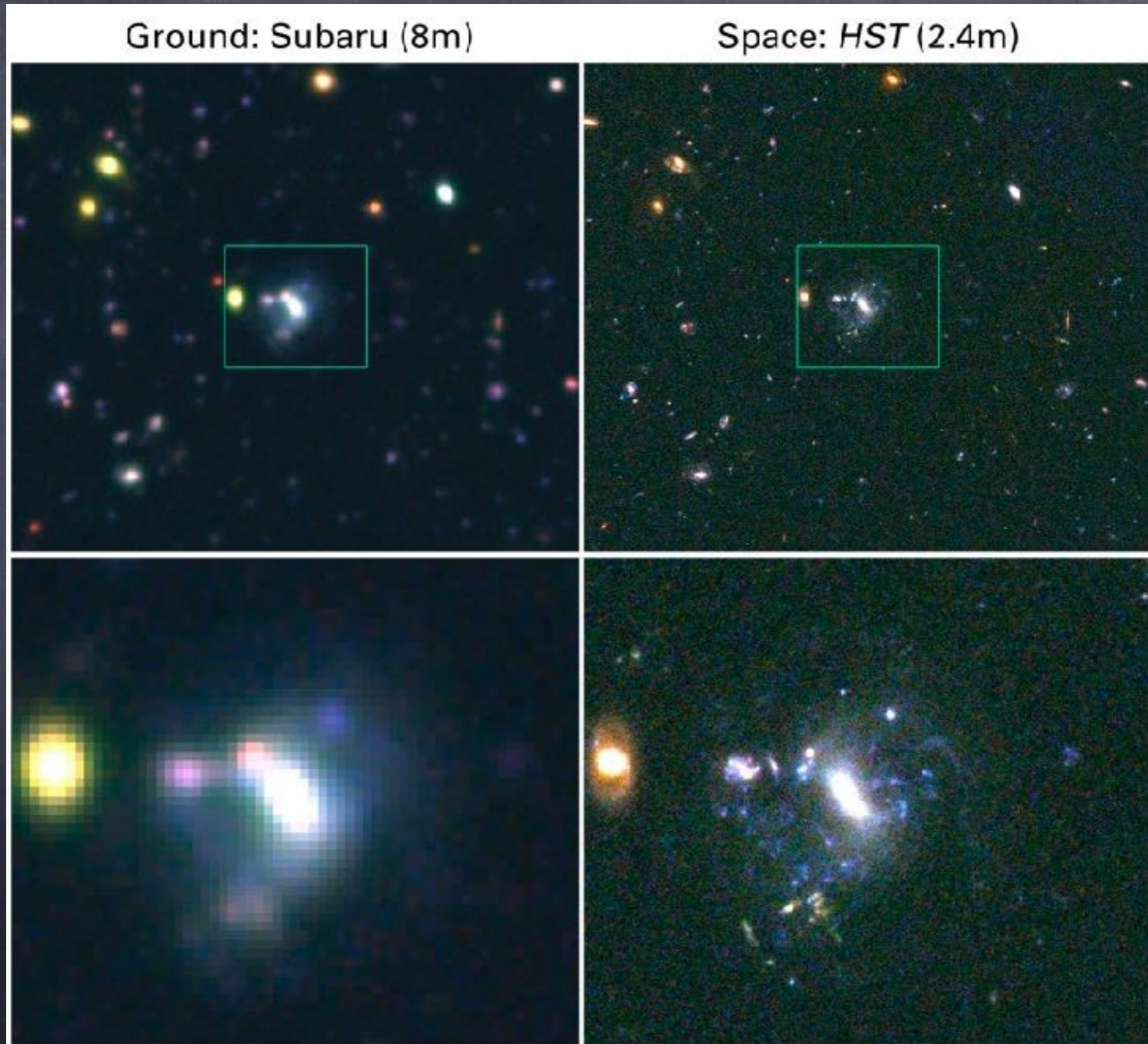

# Seeing

L'atmosfera non è omogenea ma ha una struttura di turbolenza distribuita in "bolle" al cui interno cambia l'indice di rifrazione  $n$ .

La dimensione delle bolle è in genere  $\ll$  della dimensione del telescopio.

L'onda piana attraversa zone con  $n$  diverso in cui cambia la velocità della luce.

Il risultato è che l'onda piana viene distorta. La distorsione cambia rapidissimamente portando ad una PSF molto allargata.

L'effetto è maggiore per  $\lambda$  minori.

Nei migliori telescopi la PSF risultante è  
0.5arcsec

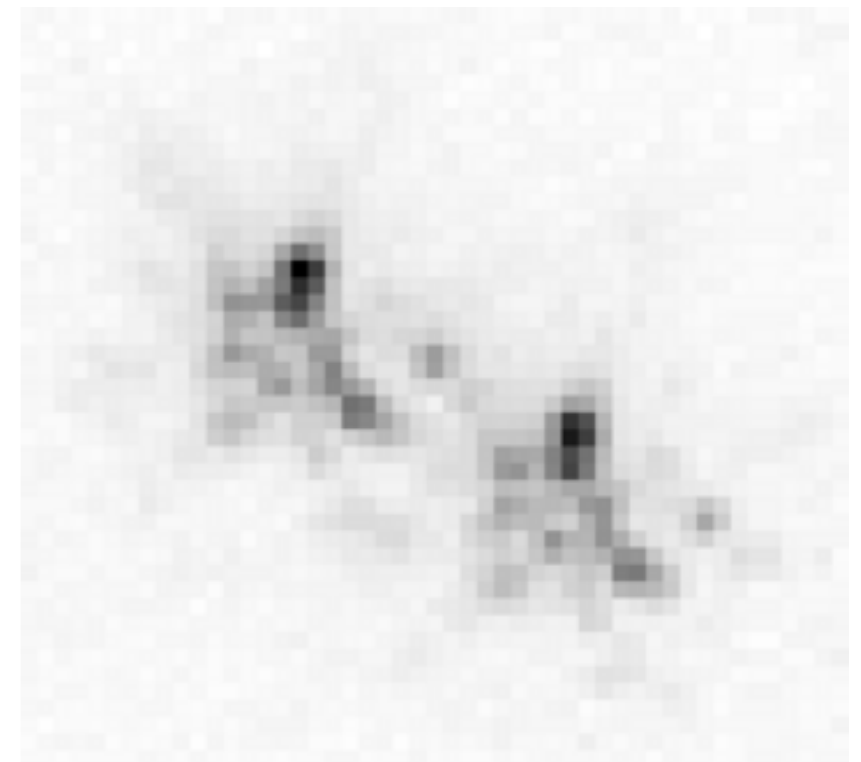
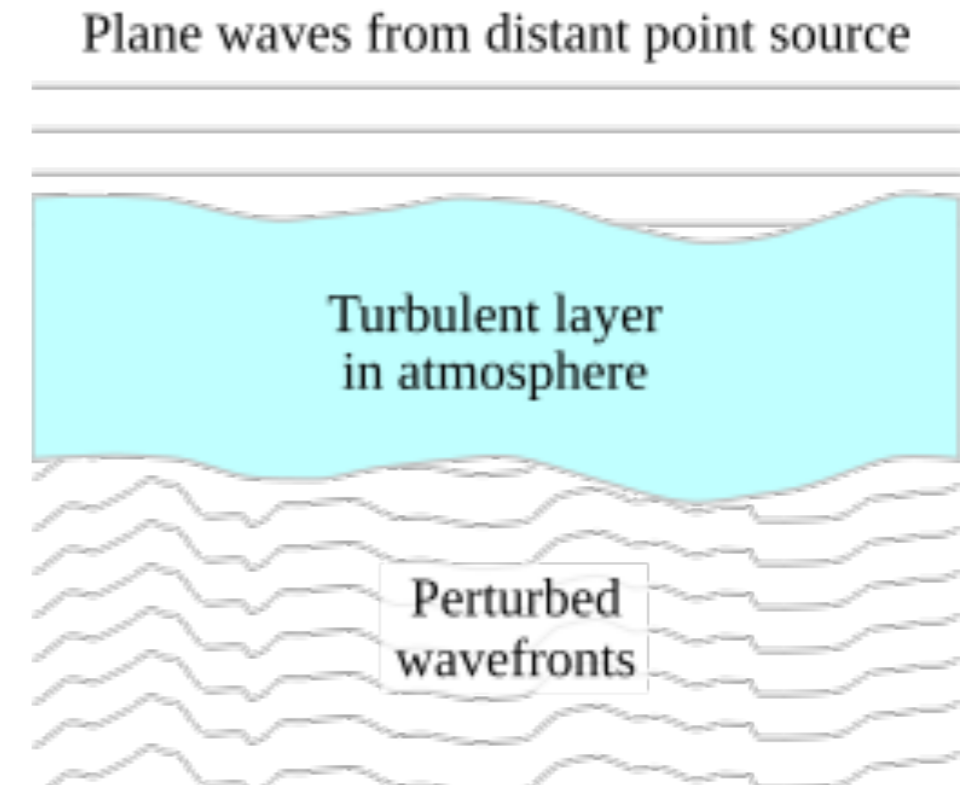

# Il “sistema telescopio” può *peggiorare* ulteriormente il seeing

I) Gradienti di temperatura interni alla cupola

Soluzione: cupole “aperte”

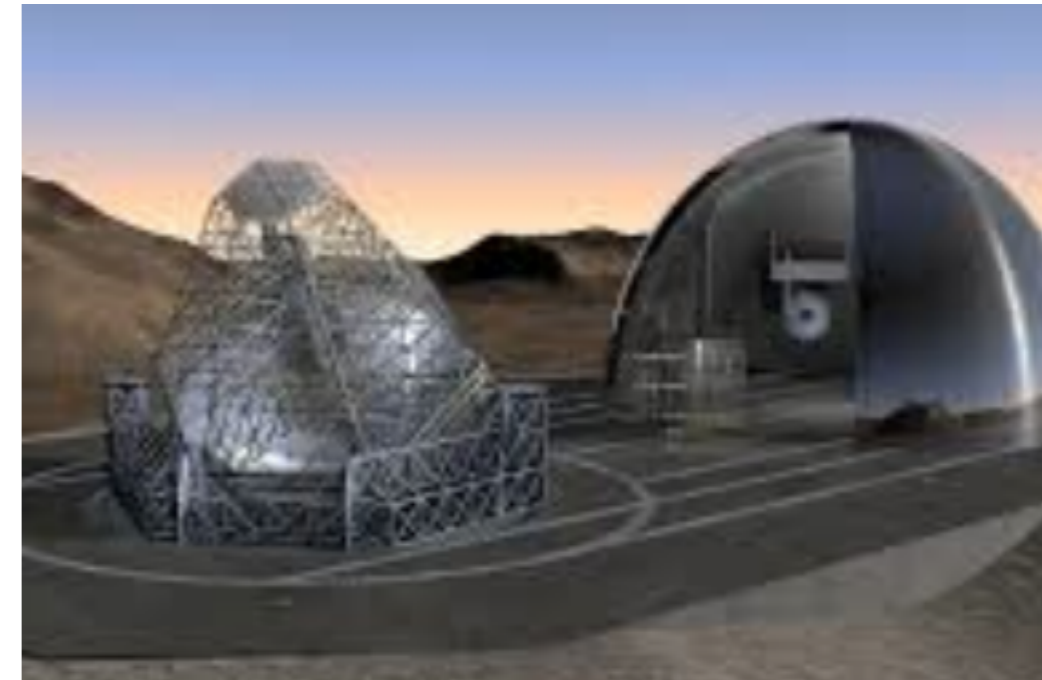



# Il “sistema telescopio” può *peggiore* ulteriormente il seeing

2) Lo specchio primario si può deformare per effetto di gravità temperatura etc:

Soluzione: ***Ottica attiva***

Un sistema di “pistoni” sotto lo specchio lo mantiene nella forma giusta.



TNG: Lato  
inferiore dello  
specchio primario

## Cosa misurano i telescopi (ottici)?

La luminosita' degli oggetti.

La luminosita' e' un flusso di energia.

Convenzionalmente si misura in  $\text{erg/cm}^2/\text{s}$

Di solito non si prende mai tutto lo spettro  $\rightarrow$  si misura il flusso per unita' di frequenza o lunghezza d'onda

### Flux Density:

$$f_{\lambda} \text{ [erg/cm}^2\text{/s/\AA]}$$

$$f_{\nu} \text{ [erg/cm}^2\text{/s/Hz]}$$

$$\text{Magnitudine: } m = -2.5 \log(f_{\nu}) + C$$

$0 < m < 6$ : visibility a occhio nudo

TNG:  $m = 18-25$

VLT:  $m = 20-27$

JWST:  $m = 24-30$

Come misurano i telescopi (ottici)?

Con dei sensori (CCD / CMOS)

I sensori sono **matrici**  
di pixel

Possono essere disposti  
a mosaico

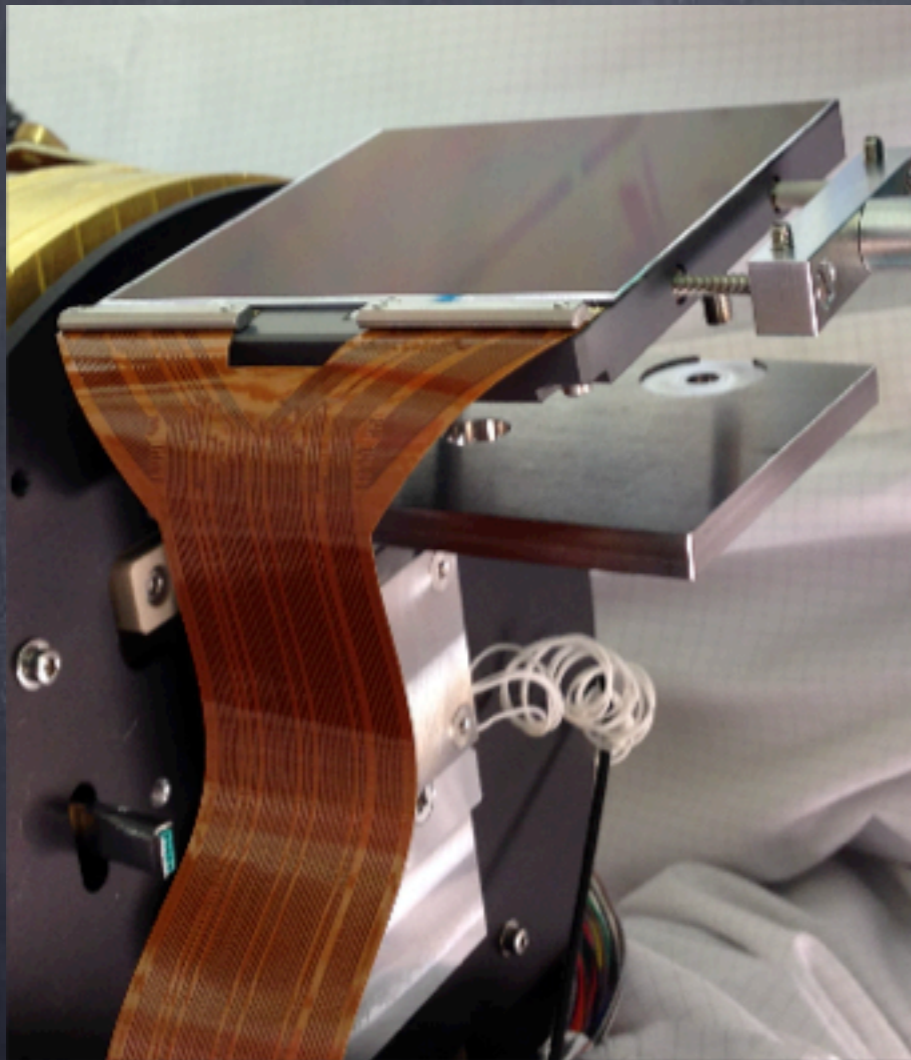

Plato  
ESA space mission

Vera Rubin  
Telescope

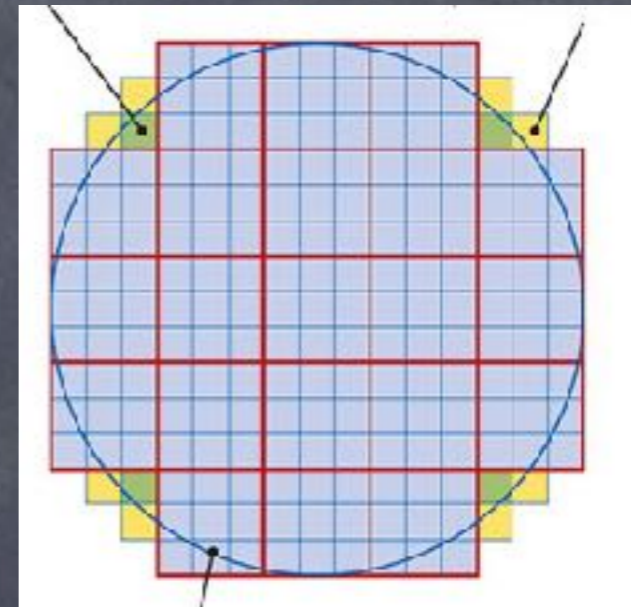

189 CCD  
4096x4096

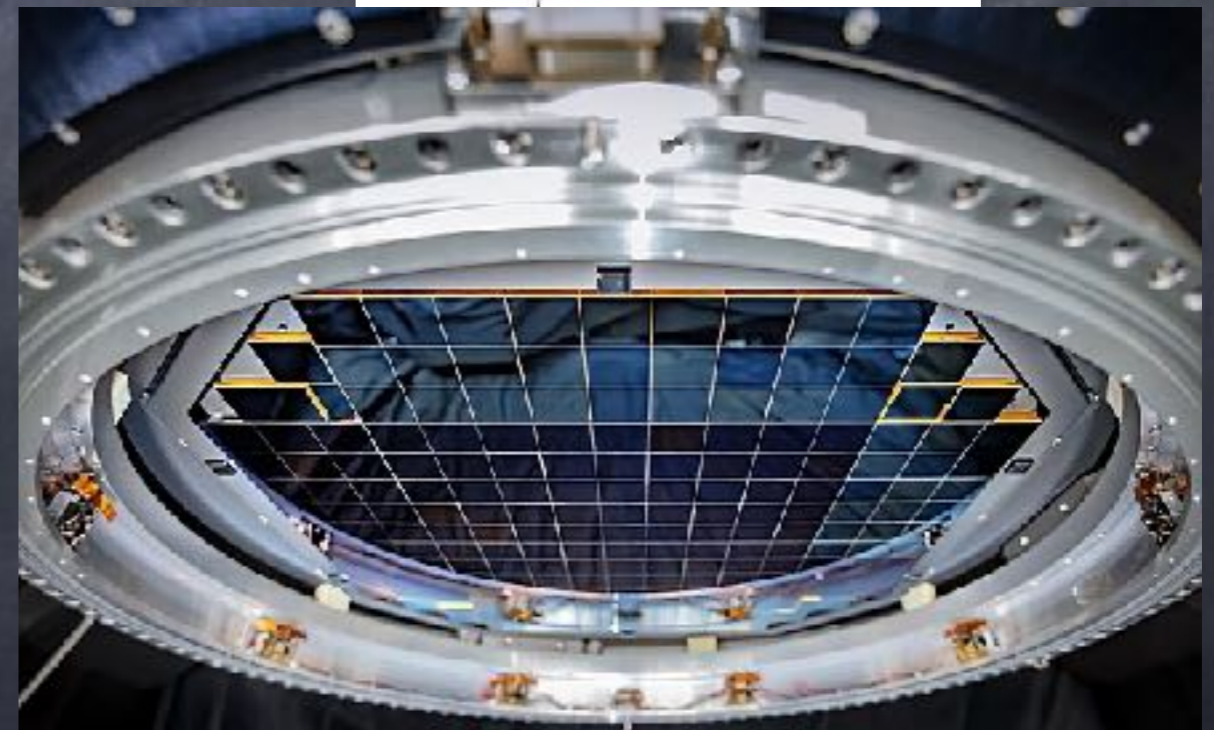

Come misurano i telescopi (ottici)?

Con dei sensori (CCD / CMOS)

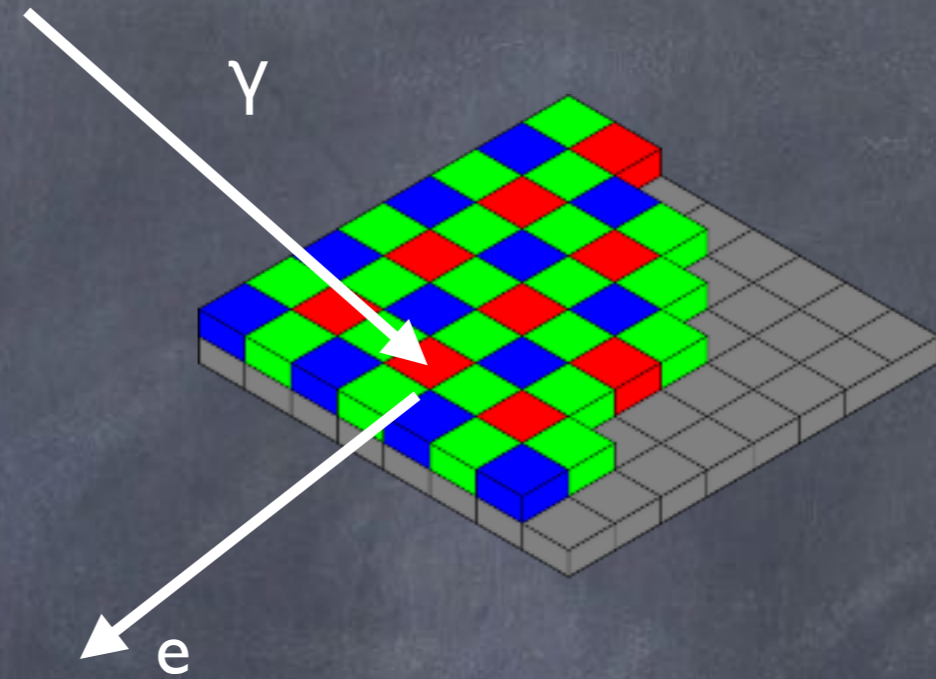

Come misurano i telescopi (ottici)?

Con dei sensori (CCD / CMOS)

Ogni pixel:

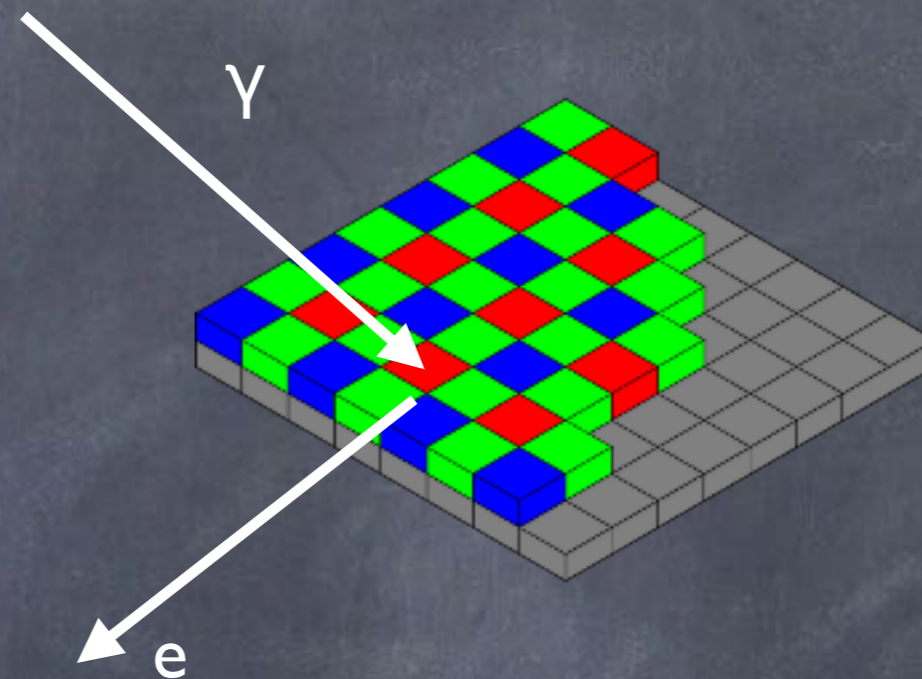

Come misurano i telescopi (ottici)?

Con dei sensori (CCD / CMOS)

Ogni pixel:

1) converte un fotone in un elettrone

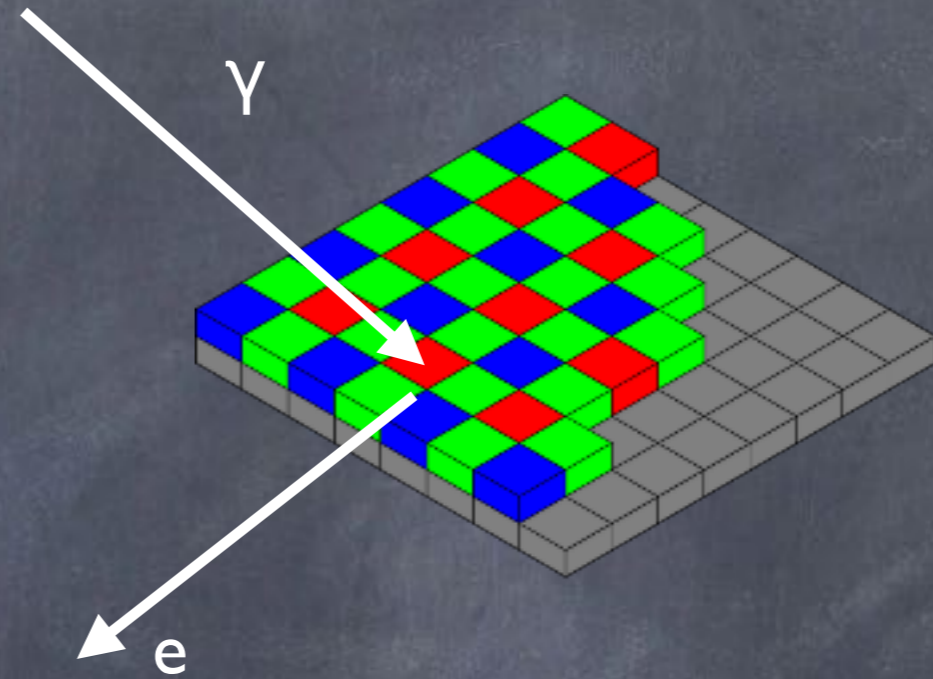

Come misurano i telescopi (ottici)?

Con dei sensori (CCD / CMOS)

Ogni pixel:

- 1) converte un fotone in un elettrone
- 2) accumula gli elettroni finché non vengono letti (CCD) o li legge in tempo reale (CMOS)

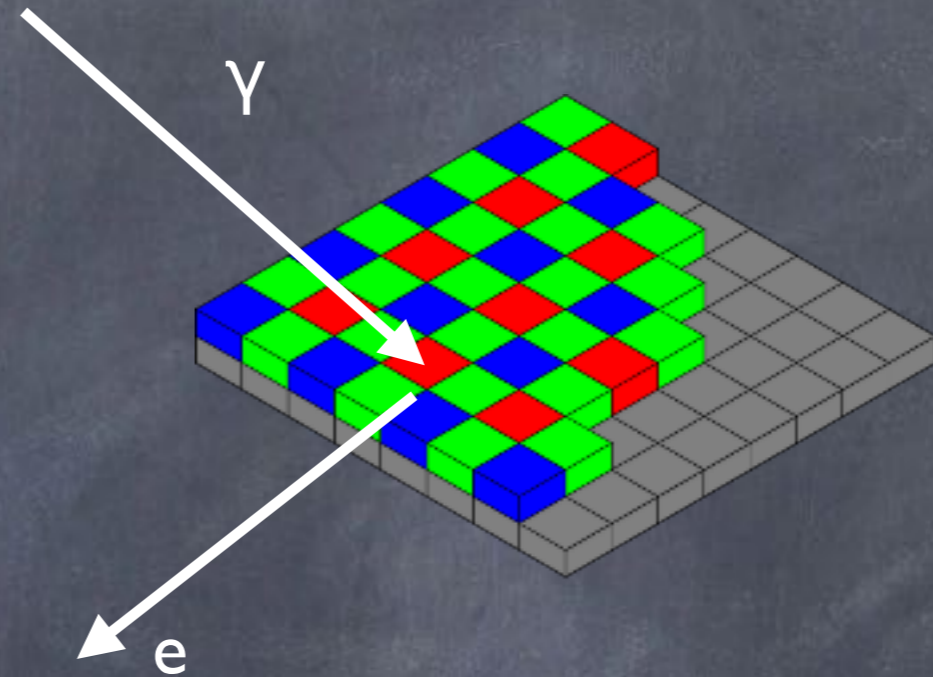

Come misurano i telescopi (ottici)?

Con dei sensori (CCD / CMOS)

Ogni pixel:

- 1) converte un fotone in un elettrone
- 2) accumula gli elettroni finché non vengono letti (CCD) o li legge in tempo reale (CMOS)

$$n_e \propto n_\gamma \propto \frac{f_\nu}{h\nu}$$

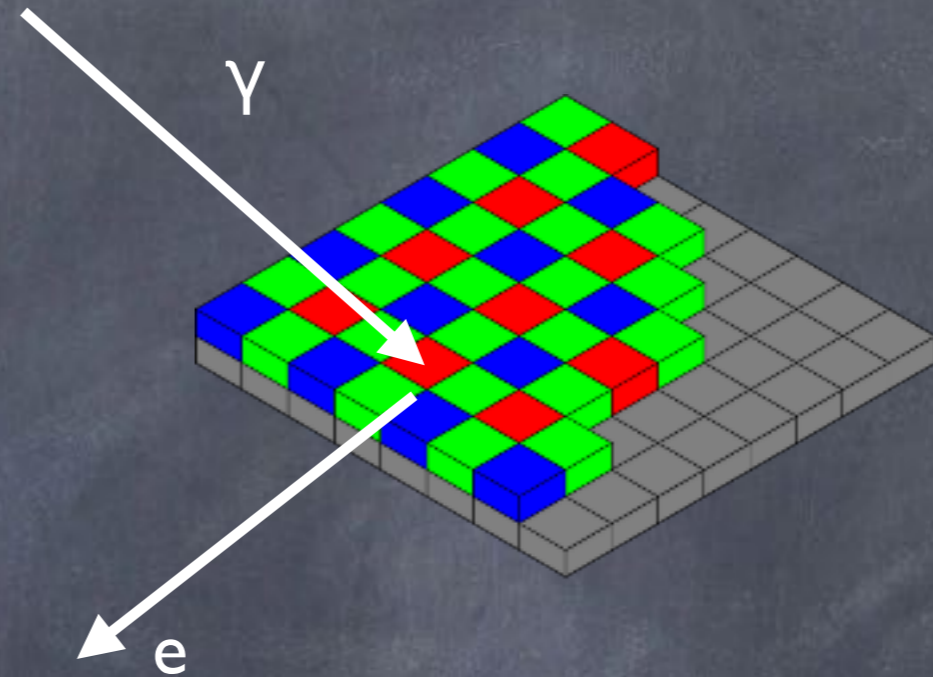



Come misurano i telescopi (ottici)?

Con dei sensori (CCD / CMOS)

Ogni pixel:

- 1) converte un fotone in un elettrone
- 2) accumula gli elettroni finché non vengono letti (CCD) o li legge in tempo reale (CMOS)

$$n_e \propto n_\gamma \propto \frac{f_\nu}{h\nu}$$

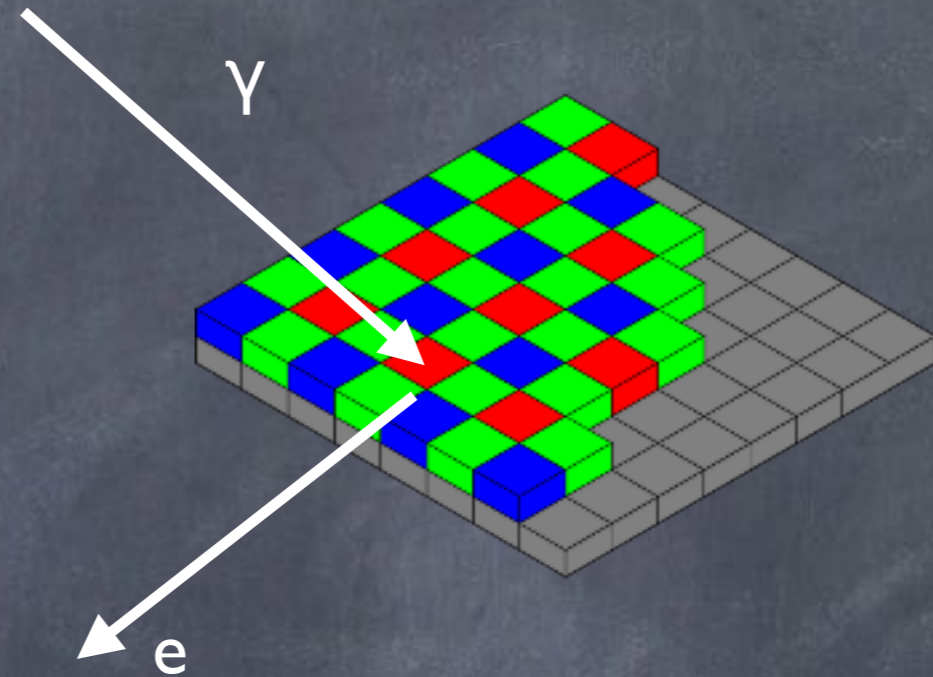

Ogni pixel misura la densità di flusso proveniente dalla zona di cielo sottesa.

Le immagini non sono "artistiche"  
Sono misure di intensità in ogni pixel del cielo

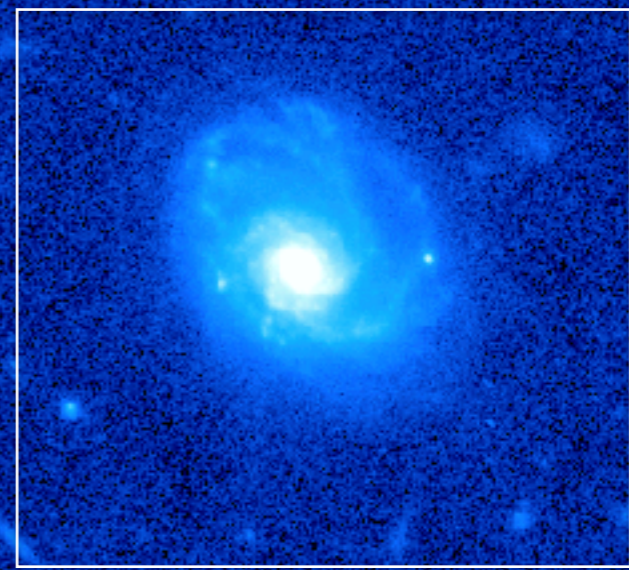

-0.00019    -0.00015    -0.00006    0.00010    0.00344    0.00110    0.00243    0.00510    0.01038

Le immagini non sono "artistiche"  
Sono misure di intensità in ogni pixel del cielo



Le immagini non sono "artistiche"  
Sono misure di intensità in ogni pixel del cielo



Le immagini prodotte dal sensore vanno calibrate.  
Non è una procedura "estetica" ma una procedura "fisica" di calibrazione +  
rimozione segnali elettronici

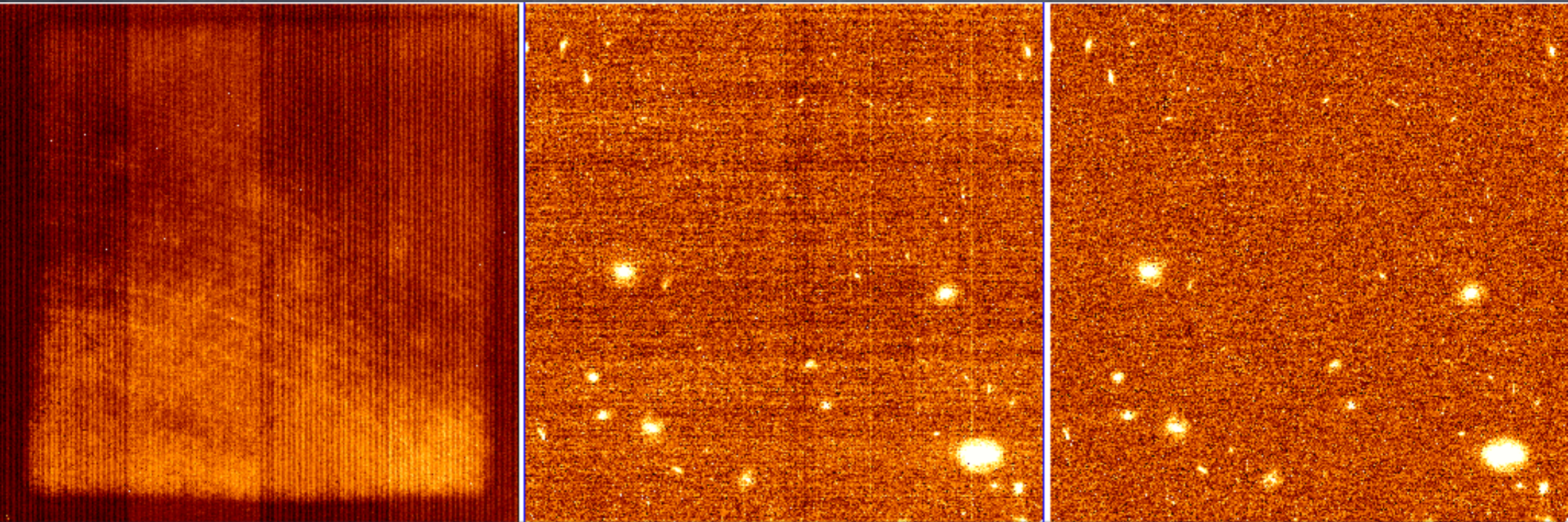



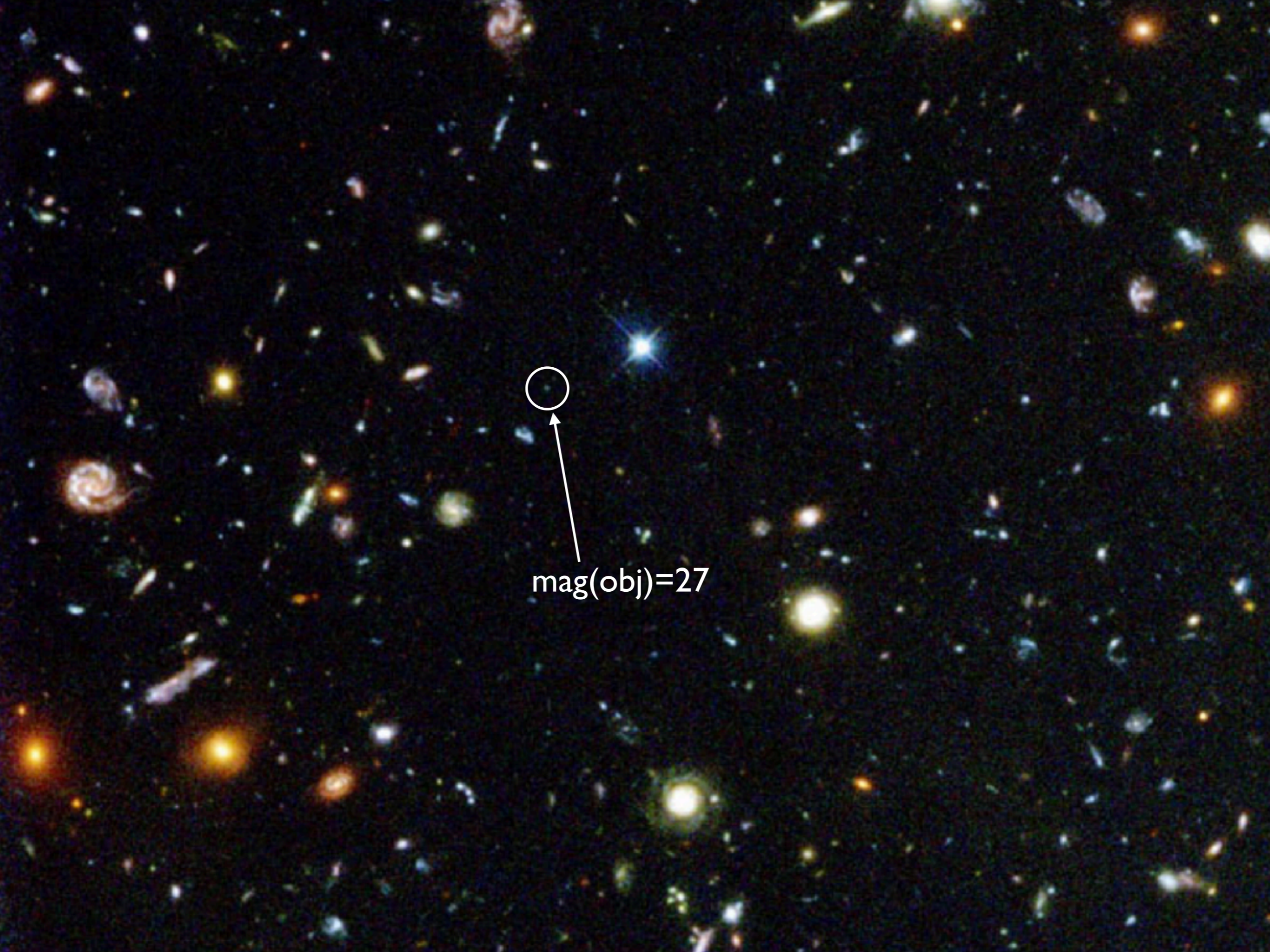

mag(obj)=27

The background is **thousands** of times brighter than most sources  
(e.g. galaxies in the distant Universe or faint stars in our/nearby galaxies)

mag(back)=20



mag(obj)=27

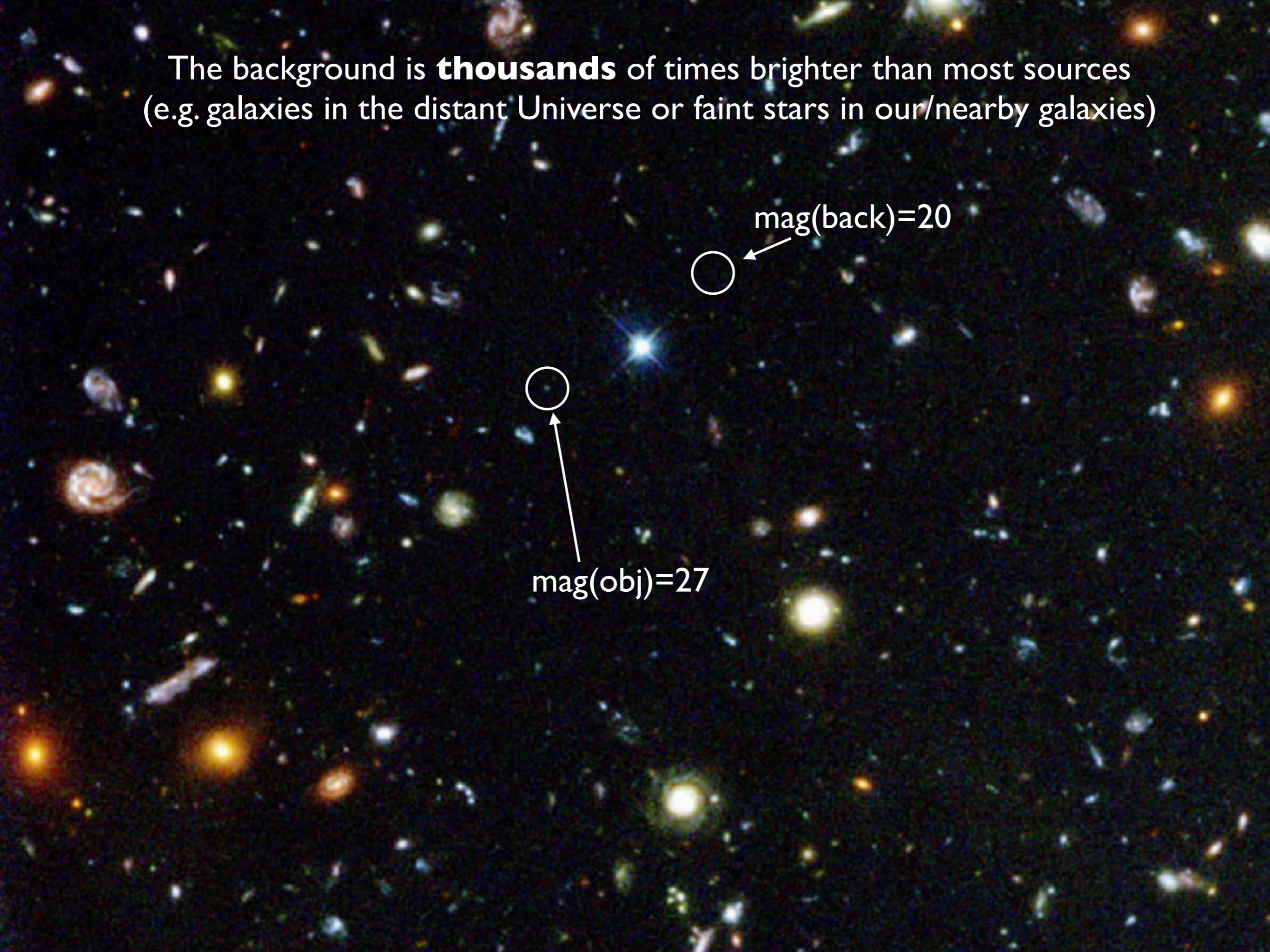



## Background sources

- 1) Thermal radiation from instruments & atmosphere  
Effective at  $\lambda > 20000\text{\AA}$ .
- 2) Skylines from atmosphere (molecules)  
Increasingly important at  $\lambda > 6000\text{\AA}$
- 3) Sunlight reflected by Moon (UV/Visible)  
Effective 15 days/month...
- 4) Zodiacal Light (sunlight reflected from minor bodies of solar system) .. inevitable!
- 5) Dust cirrus in the Galaxy (long wavelengths)  
depend on direction; lower for high latitude
- 6) Cosmic rays and other high energy particles (high energy satellites)

# OH Sky lines in the optical /near IR

P. Rousselot et al.: Night-sky spectral atlas of OH emission lines

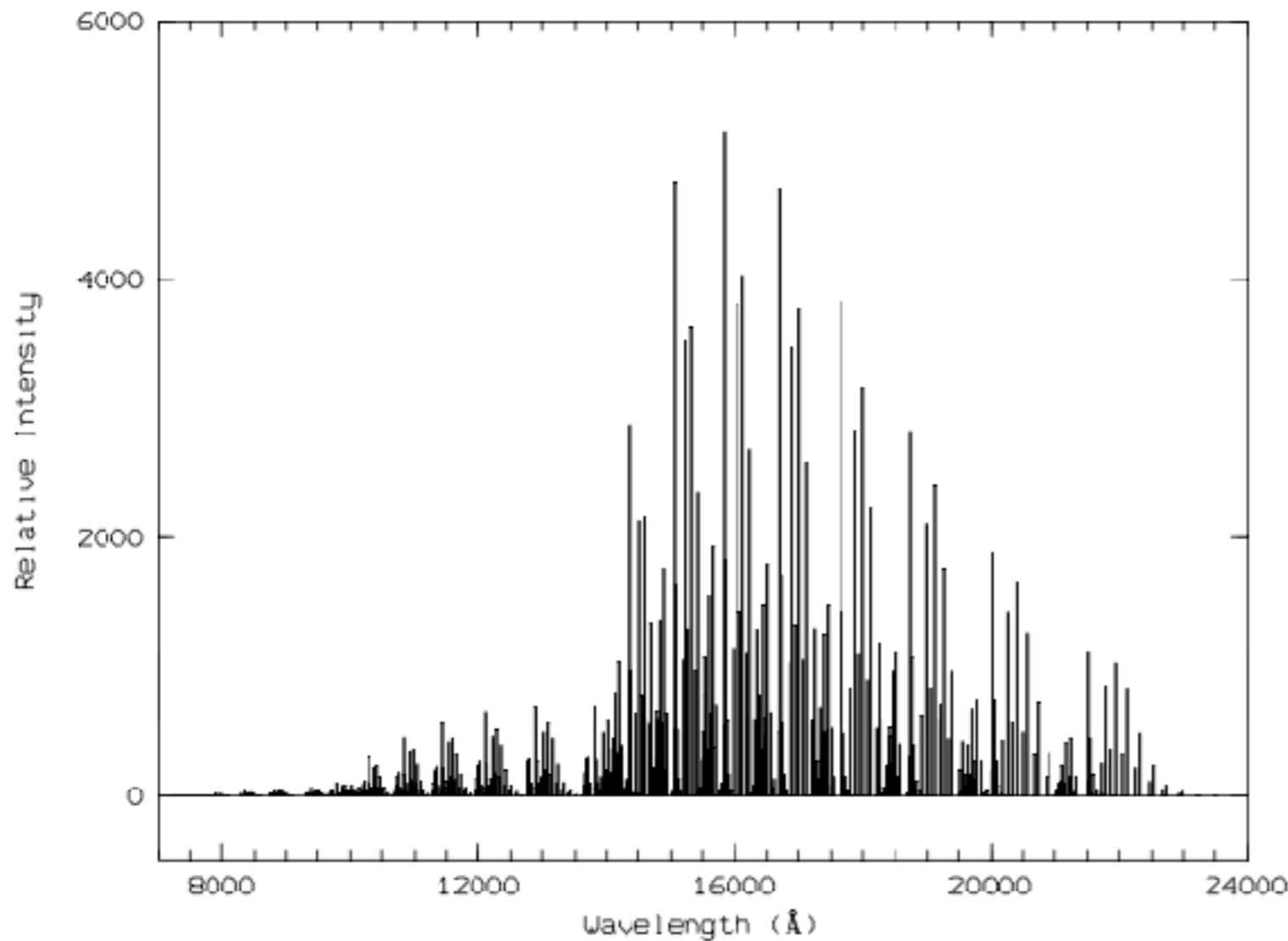
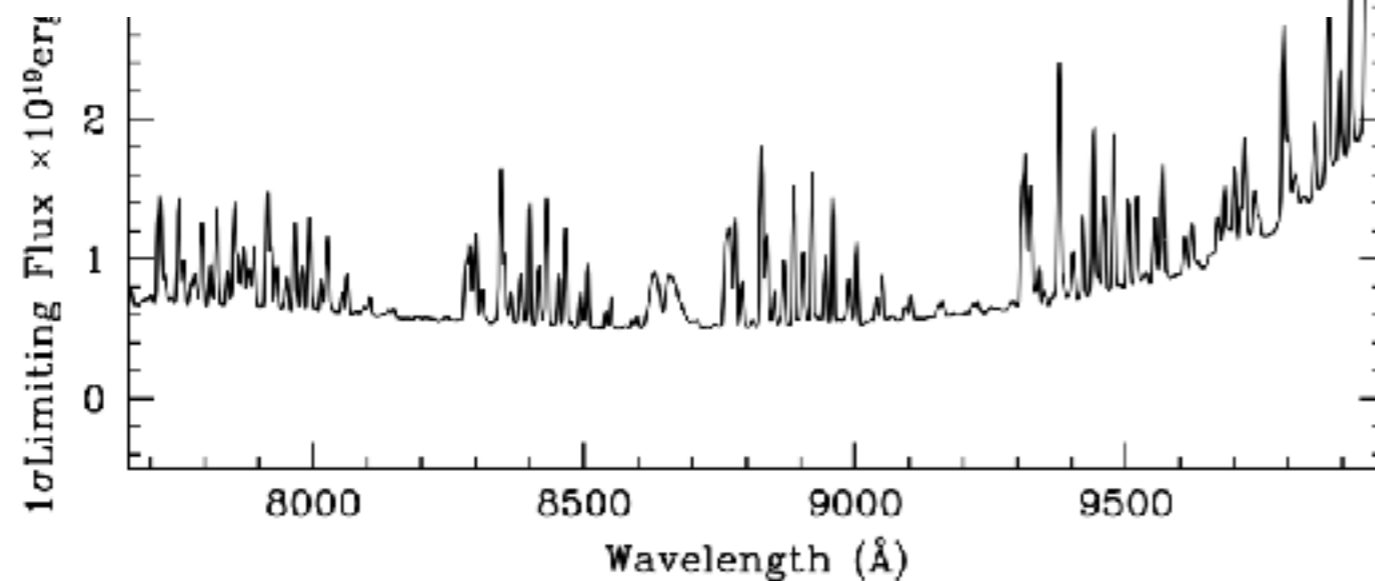

Table 12: La Palma Sky Bright

U	B	V	R	I	Moon
21.4	22.3	21.4	20.4	19.3	Dark
21.0	21.8	20.8	20.4	19.4	Dark
19.9	20.3	20.1	19.6	19.0	Grey
17.4	17.4	16.9	17.5	17.7	Bright



Come facciamo a osservare oggetti più deboli del fondo?

Ci aiuta la Statistica di Poisson

## Come facciamo a osservare oggetti più deboli del fondo?

Ci aiuta la Statistica di Poisson

Vale per eventi che accadono casualmente, successivamente e individualmente con probabilità costante nel tempo.

Per es.: decadimento radioattivo, arrivo di fotoni da una stella..

## Come facciamo a osservare oggetti più deboli del fondo?

Ci aiuta la Statistica di Poisson

Vale per eventi che accadono casualmente, successivamente e individualmente con probabilità costante nel tempo.

Per es.: decadimento radioattivo, arrivo di fotoni da una stella..

Per un processo che in un tempo  $T$  genera in media  $N$  eventi,  
il valore aspettato degli eventi misurati sarà  $N$   
distribuito con una distribuzione gaussiana(\*) con  $\sigma = \sqrt{N}$

(\*) Approssimazione valida per  $N > 10$

## Come facciamo a osservare oggetti più deboli del fondo?

Ci aiuta la Statistica di Poisson

Vale per eventi che accadono casualmente, successivamente e individualmente con probabilità costante nel tempo.

Per es.: decadimento radioattivo, arrivo di fotoni da una stella..

Per un processo che in un tempo  $T$  genera in media  $N$  eventi, il valore aspettato degli eventi misurati sarà  $N$  distribuito con una distribuzione gaussiana(\*) con  $\sigma = \sqrt{N}$

Esempio: fenomeno con <i>in media</i> 10 eventi al secondo					
Secondi	Eventi	Dev. Std. $\sigma$	Misura: Eventi/s	Errore: $\sigma/s$	S/N = Misura / $\sigma$
1	9	3,0	9	3,00	3,0
10	109	10,4	10,9	1,04	10,4
100	975	31,2	9,75	0,31	31,2
1.000	10.095	100,5	10,095	0,10	100,5

(\*) Approssimazione valida per  $N > 10$

Il “fondo cielo” genera nei pixel di un rivelatore un segnale  $B$  distribuito secondo statistica di Poisson, ovvero come una gaussiana con valore medio  $B$  e deviazione standard  $\sigma = \sqrt{B}$

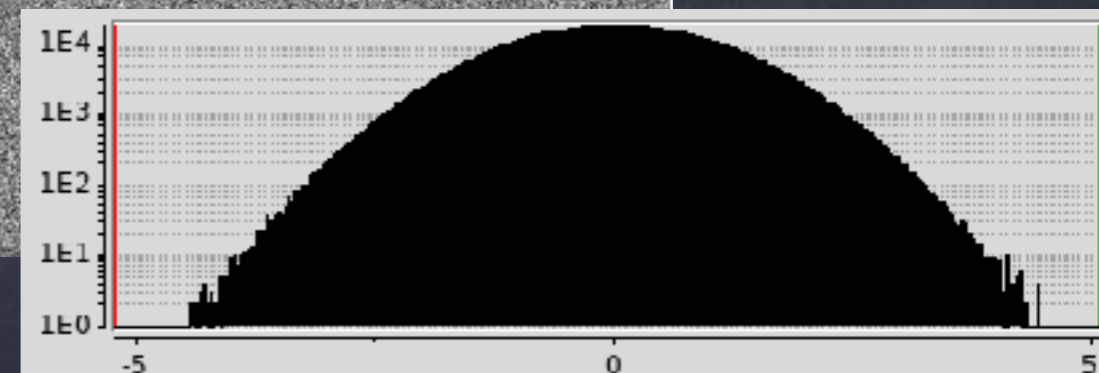

Fondo = 10c/s, stella = 1c/s

Secondi	Fondo	DevStd Fondo	Oggetto	Oggetto/DevStd
1	10,0	3,2	1,0	0,3
10	100,0	10,0	10,0	1,0
100	1.000,0	31,6	100,0	3,2
1.000	10.000,0	100,0	1.000,0	10,0

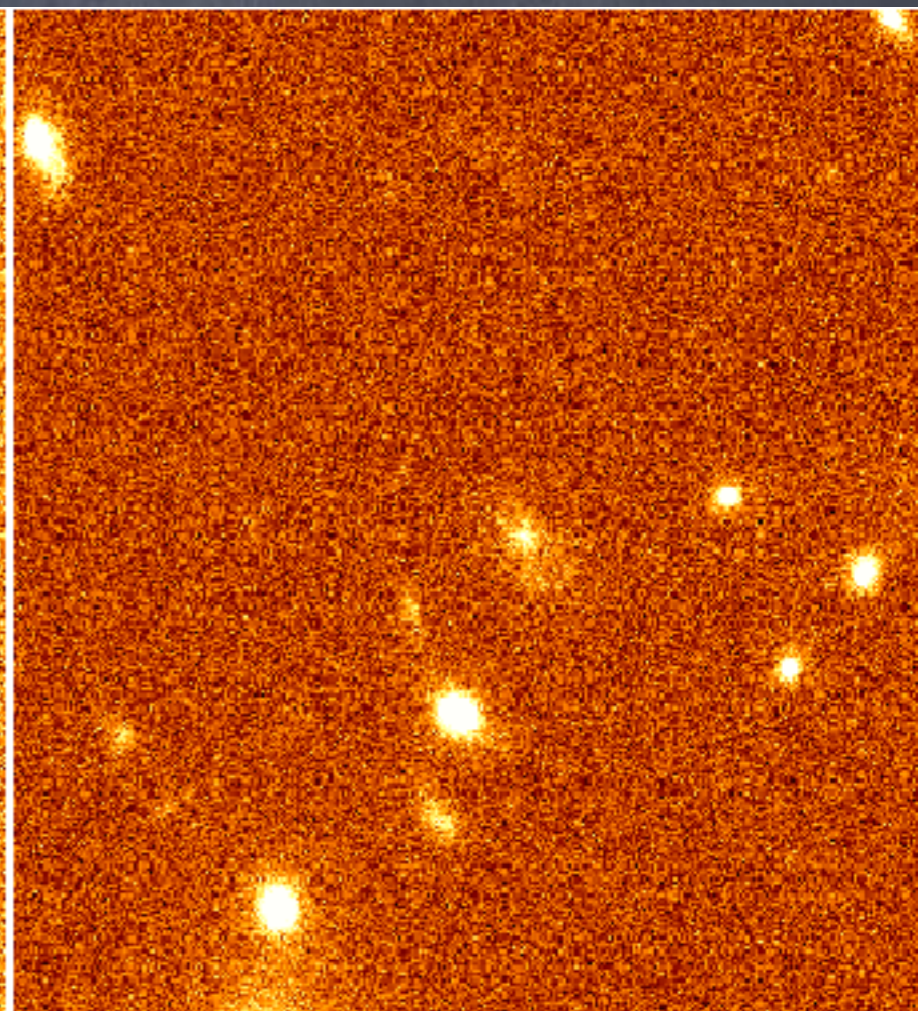
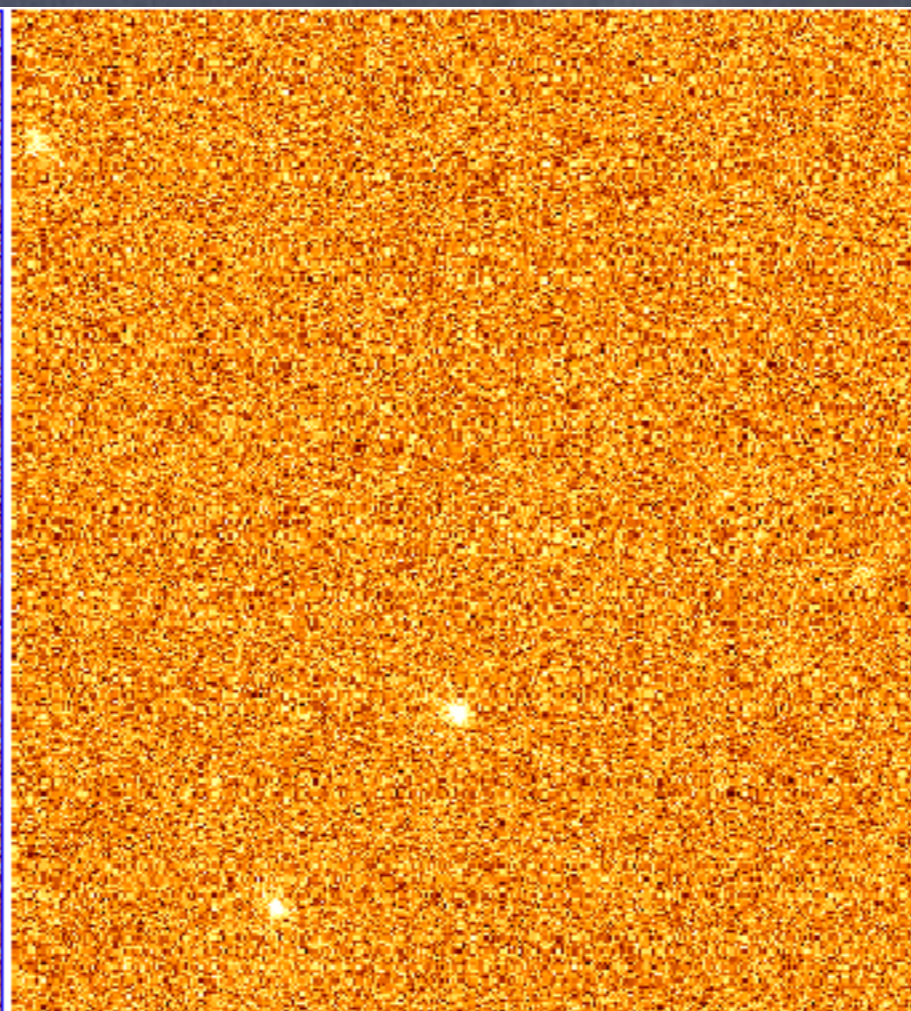
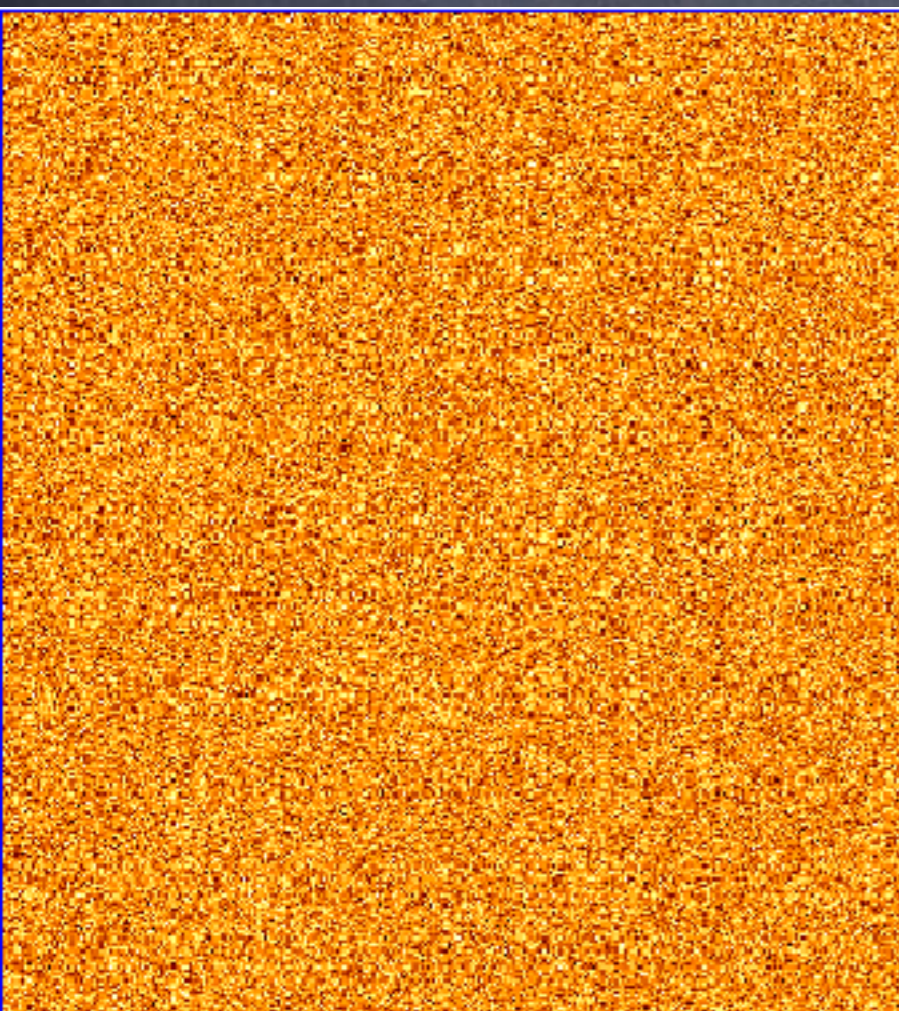



Segnale prodotto da un oggetto osservato ad un telescopio di diametro  $D$   
in un tempo di posa  $T$

$$S_\nu = \frac{f_\nu}{h\nu} \times \frac{\pi}{4} D^2 \times T \times \epsilon_\nu$$

Numero  
fotoni

Area  
Telescopio

Tempo  
posa

Efficienza

The diagram illustrates the components of the signal equation. The equation is written in orange:  $S_\nu = \frac{f_\nu}{h\nu} \times \frac{\pi}{4} D^2 \times T \times \epsilon_\nu$ . Four white arrows point from labels below to specific parts of the equation: 'Numero fotoni' points to  $f_\nu$ , 'Area Telescopio' points to  $\frac{\pi}{4} D^2$ , 'Tempo posa' points to  $T$ , and 'Efficienza' points to  $\epsilon_\nu$ .

Rumore di misura sullo stesso oggetto osservato ad un telescopio di diametro  $D$  in un tempo di posa  $T$

Rumore di misura sullo stesso oggetto osservato ad un telescopio di diametro  $D$  in un tempo di posa  $T$

I) Rumore “di lettura” (read-out noise): fattore costante  $\sigma_{ron}$

Rumore di misura sullo stesso oggetto osservato ad un telescopio di diametro  $D$  in un tempo di posa  $T$

- 1) Rumore “di lettura” (read-out noise): fattore costante  $\sigma_{ron}$
- 2) Rumore Poisson sul segnale misurato: Oggetto + Fondo Cielo  $\sigma_B$

Rumore di misura sullo stesso oggetto osservato ad un telescopio di diametro  $D$  in un tempo di posa  $T$

1) Rumore “di lettura” (read-out noise): fattore costante  $\sigma_{ron}$

2) Rumore Poisson sul segnale misurato: Oggetto + Fondo Cielo  $\sigma_B$

$$\sigma_B = \sqrt{\frac{f_\nu + B_\nu}{h\nu} \times \frac{\pi}{4} D^2 \times T \times \epsilon_\nu}$$

Numero fotoni oggetto + cielo

Area Telescopio

Tempo posa

Efficienza

Rumore di misura sullo stesso oggetto osservato ad un telescopio di diametro  $D$  in un tempo di posa  $T$

Gli errori si sommano quadraticamente

$$\sigma_{TOT}^2 = \sigma_{ron}^2 + \sigma_B^2$$

Rumore di misura sullo stesso oggetto osservato ad un telescopio di diametro  $D$  in un tempo di posa  $T$

Gli errori si sommano quadraticamente

$$\sigma_{TOT}^2 = \sigma_{ron}^2 + \sigma_B^2$$

$$\sigma_{TOT} = \sqrt{\sigma_{ron}^2 + \frac{f_\nu + B_\nu}{h\nu} \times \frac{\pi}{4} D^2 \times T \times \epsilon_\nu}$$

Rapporto Segnale / Rumore per un oggetto osservato ad un telescopio di diametro  $D$  in un tempo di posa  $T$

$$\frac{S}{N} = \frac{\frac{f_\nu}{h\nu} \frac{\pi}{4} D^2 T \epsilon_\nu}{\sqrt{\sigma_{ron}^2 + \frac{(f_\nu + B_\nu)}{h\nu} \frac{\pi}{4} D^2 T \epsilon_\nu}}$$



Rapporto Segnale / Rumore per un oggetto osservato ad un telescopio di diametro  $D$  in un tempo di posa  $T$

$$\text{Caso I: } \sigma_{ron}^2 \gg \frac{(f_\nu + B_\nu) \pi}{h\nu} \frac{D^2 T \epsilon_\nu}{4}$$

Dominati dal rumore di lettura

( $T$  è molto piccolo

o

( $f_\nu + B_\nu$ ) è molto piccolo)

$$\frac{S}{N} = \frac{\frac{f_\nu \pi}{h\nu} \frac{D^2 T \epsilon_\nu}{4}}{\sqrt{\sigma_{ron}^2 + \frac{(f_\nu + B_\nu) \pi}{h\nu} \frac{D^2 T \epsilon_\nu}{4}}}$$

Rapporto Segnale / Rumore per un oggetto osservato ad un telescopio di diametro  $D$  in un tempo di posa  $T$

$$\text{Caso I: } \sigma_{ron}^2 \gg \frac{(f_\nu + B_\nu) \pi}{h\nu} \frac{D^2 T \epsilon_\nu}{4}$$

$$\frac{S}{N} = \frac{\frac{f_\nu \pi}{h\nu} \frac{D^2 T \epsilon_\nu}{4}}{\sqrt{\sigma_{ron}^2 + \frac{(f_\nu + B_\nu) \pi}{h\nu} \frac{D^2 T \epsilon_\nu}{4}}}$$

Dominati dal rumore di lettura

( $T$  è molto piccolo

o

( $f_\nu + B_\nu$ ) è molto piccolo)

$$\frac{S}{N} \propto f_\nu \times D^2 \epsilon \times T$$

Il S/N cresce rapidamente con tempo di posa ( $T$ ) e molto rapidamente con le dimensioni del telescopio ( $D^2$ )

Rapporto Segnale / Rumore per un oggetto osservato ad un telescopio di diametro  $D$  in un tempo di posa  $T$

Caso I:  $\sigma_{ron}^2 \gg \frac{(f_\nu + B_\nu) \pi}{h\nu} D^2 T \epsilon_\nu$

$$\frac{S}{N} = \frac{\frac{f_\nu \pi}{h\nu} D^2 T \epsilon_\nu}{\sqrt{\sigma_{ron}^2 + \frac{(f_\nu + B_\nu) \pi}{h\nu} D^2 T \epsilon_\nu}}$$

Dominati dal rumore di lettura

( $T$  è molto piccolo

o

( $f_\nu + B_\nu$ ) è molto piccolo)

$$\frac{S}{N} \propto f_\nu \times D^2 \epsilon \times T$$

Il S/N cresce rapidamente con tempo di posa ( $T$ ) e molto rapidamente con le dimensioni del telescopio ( $D^2$ )

$f_{limit}$ : Oggetto più debole che potete osservare con un dato S/N

$$f_{limit} \propto \frac{S}{N} D^{-2} T^{-1}$$

Rapporto Segnale / Rumore per un oggetto osservato ad un telescopio di diametro  $D$  in un tempo di posa  $T$

Caso 2:  $B_\nu \gg f_\nu, \sigma_{ron}^2$

Dominati dal Fondo Cielo  
e/o  $T$  è grande

$$\frac{S}{N} = \frac{\frac{f_\nu}{h\nu} \frac{\pi}{4} D^2 T \epsilon_\nu}{\sqrt{\cancel{\sigma_{ron}^2} + \frac{(f_\nu + B_\nu)}{h\nu} \frac{\pi}{4} D^2 T \epsilon_\nu}}$$

Rapporto Segnale / Rumore per un oggetto osservato ad un telescopio di diametro  $D$  in un tempo di posa  $T$

Caso 2:  $B_\nu \gg f_\nu, \sigma_{ron}^2$

Dominati dal Fondo Cielo  
e/o  $T$  è grande

$$\frac{S}{N} = \frac{\frac{f_\nu}{h\nu} \frac{\pi}{4} D^2 T \epsilon_\nu}{\sqrt{\cancel{\sigma_{ron}^2} + \frac{(f_\nu + B_\nu)}{h\nu} \frac{\pi}{4} D^2 T \epsilon_\nu}}$$

$$\frac{S}{N} \propto f_\nu \times D \epsilon^{1/2} \times T^{1/2} B^{-1/2}$$

Il S/N cresce lentamente con tempo di posa ( $T^{1/2}$ ) e linearmente con le dimensioni del telescopio ( $D$ )

Rapporto Segnale / Rumore per un oggetto osservato ad un telescopio di diametro  $D$  in un tempo di posa  $T$

Caso 2:  $B_\nu \gg f_\nu, \sigma_{ron}^2$

Dominati dal Fondo Cielo  
e/o  $T$  è grande

$$\frac{S}{N} = \frac{\frac{f_\nu}{h\nu} \frac{\pi}{4} D^2 T \epsilon_\nu}{\sqrt{\sigma_{ron}^2 + \frac{(f_\nu + B_\nu)}{h\nu} \frac{\pi}{4} D^2 T \epsilon_\nu}}$$

$$\frac{S}{N} \propto f_\nu \times D \epsilon^{1/2} \times T^{1/2} B^{-1/2}$$

Il S/N cresce lentamente con tempo di posa ( $T^{1/2}$ ) e linearmente con le dimensioni del telescopio ( $D$ )

$f_{limit}$ : Oggetto più debole che potete osservare con un dato S/N

$$f_{limit} \propto \frac{S}{N} D^{-1} T^{-1/2}$$

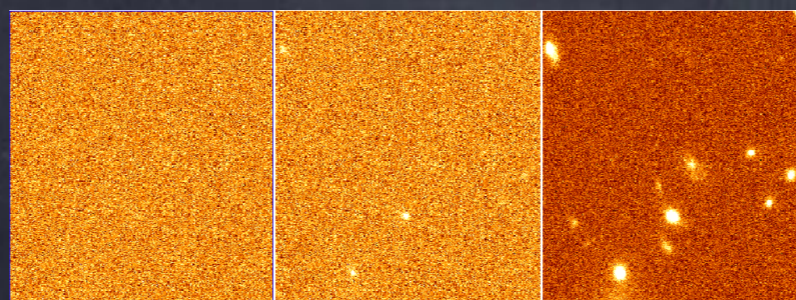



(s) 0.00036



(s) 0.00036



# Why do we need a better resolution?

2) Reduce the background --> improve S/N

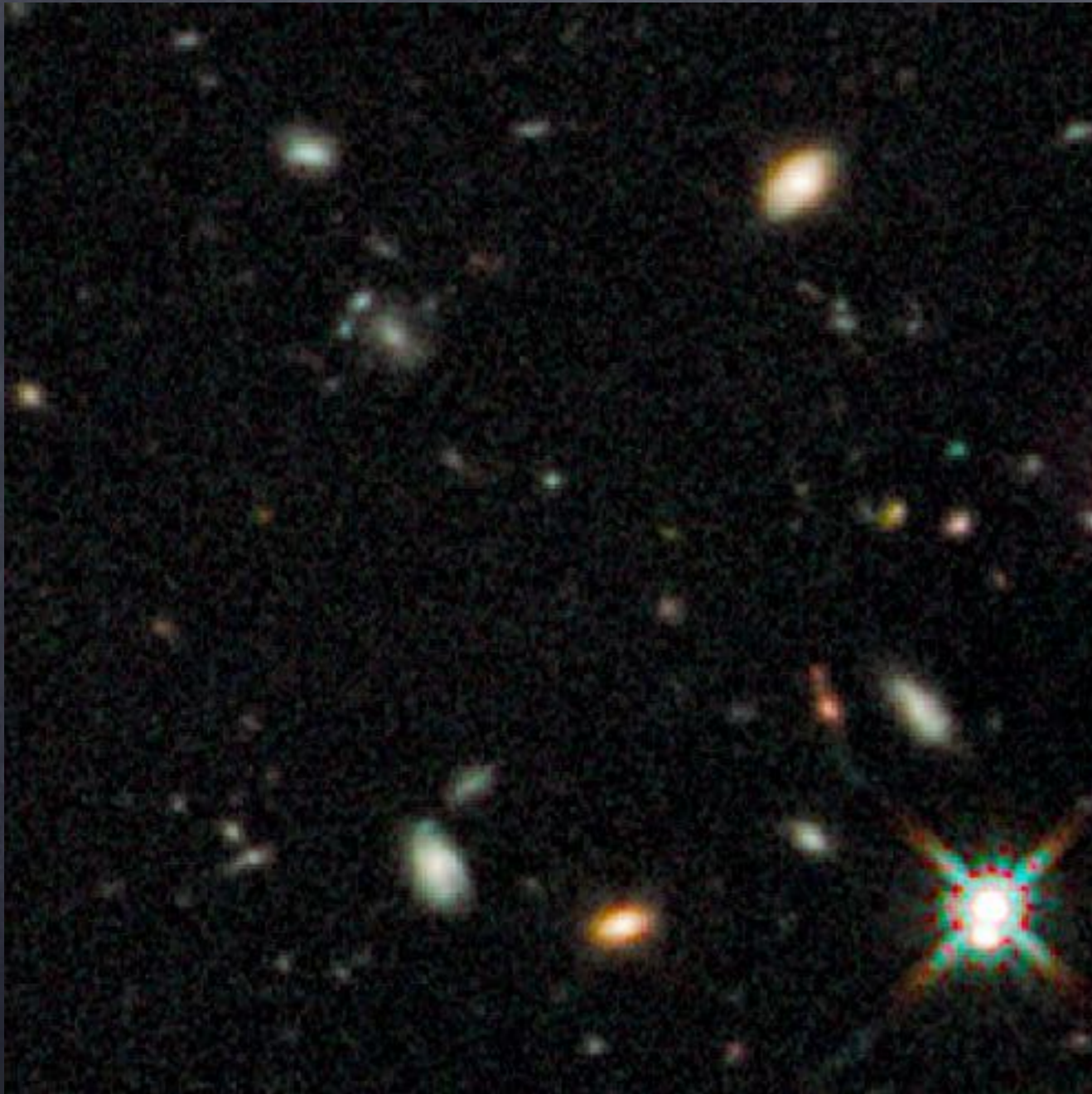

# Why do we need a better resolution?

2) Reduce the background --> improve S/N

The sky is not dark: background is  $10^2$ - $10^4$  times brighter than objects. Shot-noise (Poisson) dominates the S/N

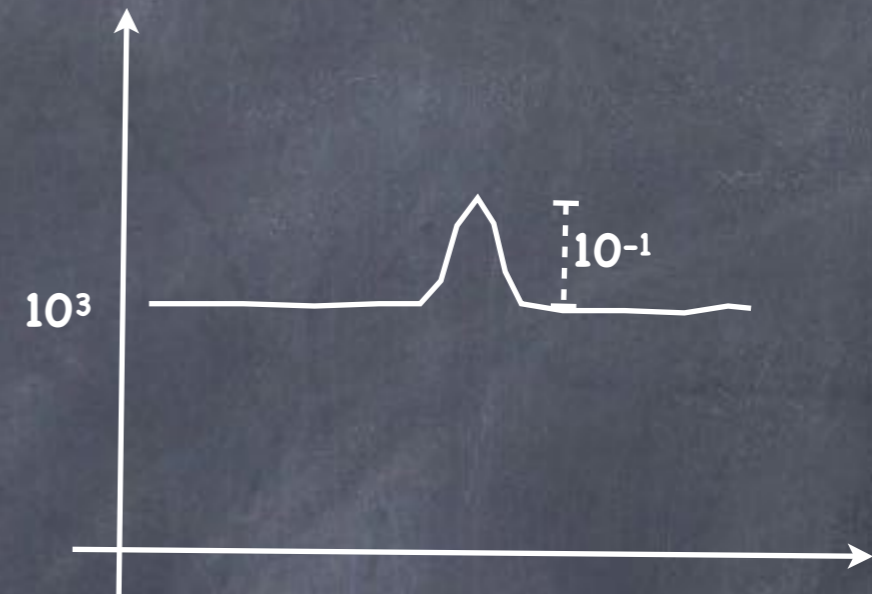
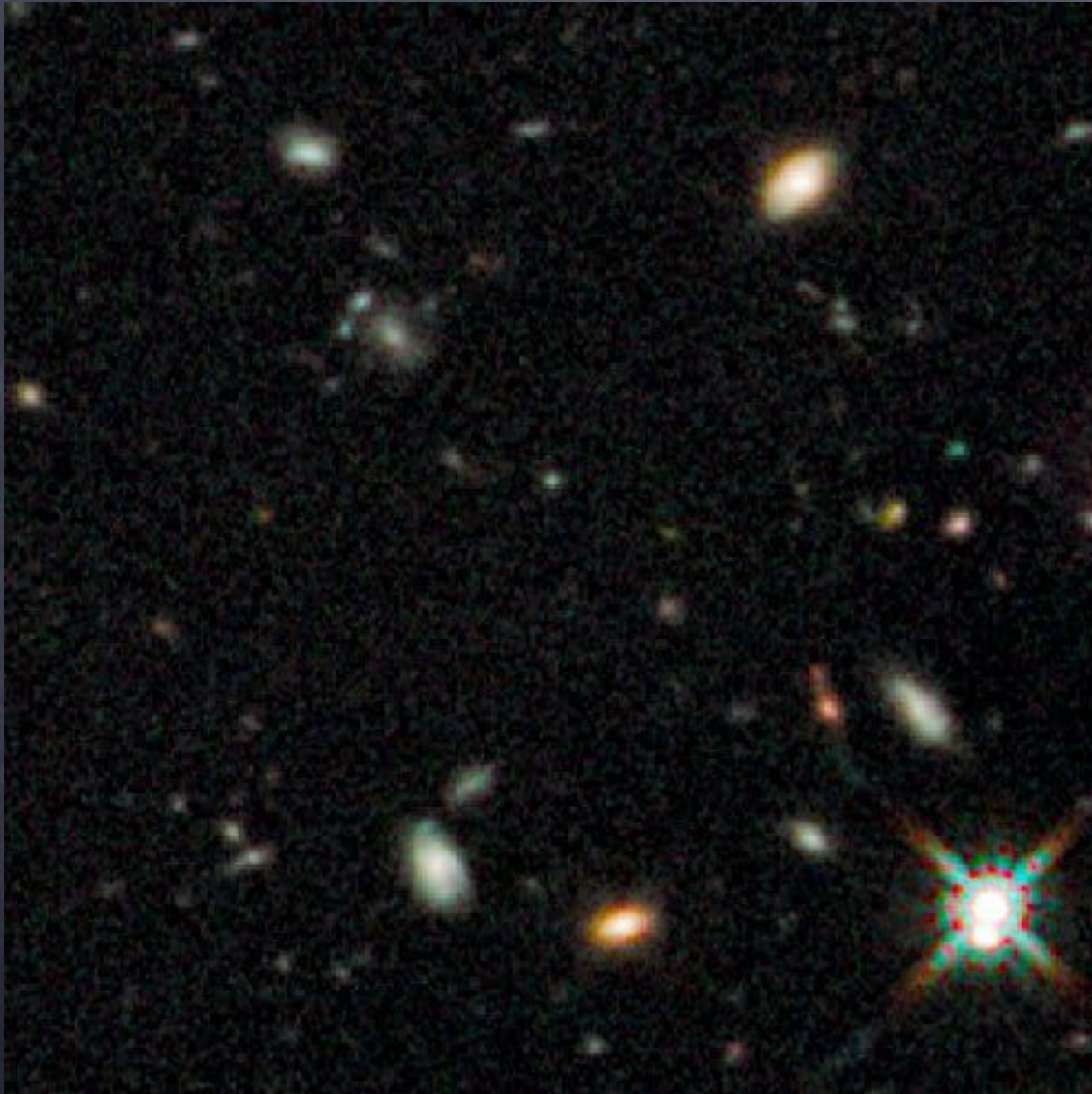

# Why do we need a better resolution?

2) Reduce the background --> improve S/N

The sky is not dark: background is  $10^2$ - $10^4$  times brighter than objects. Shot-noise (Poisson) dominates the S/N

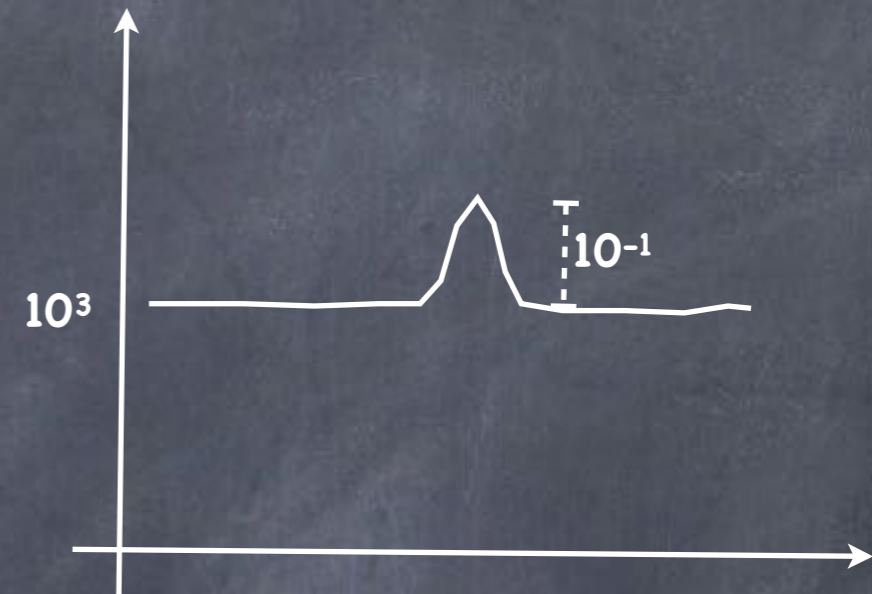
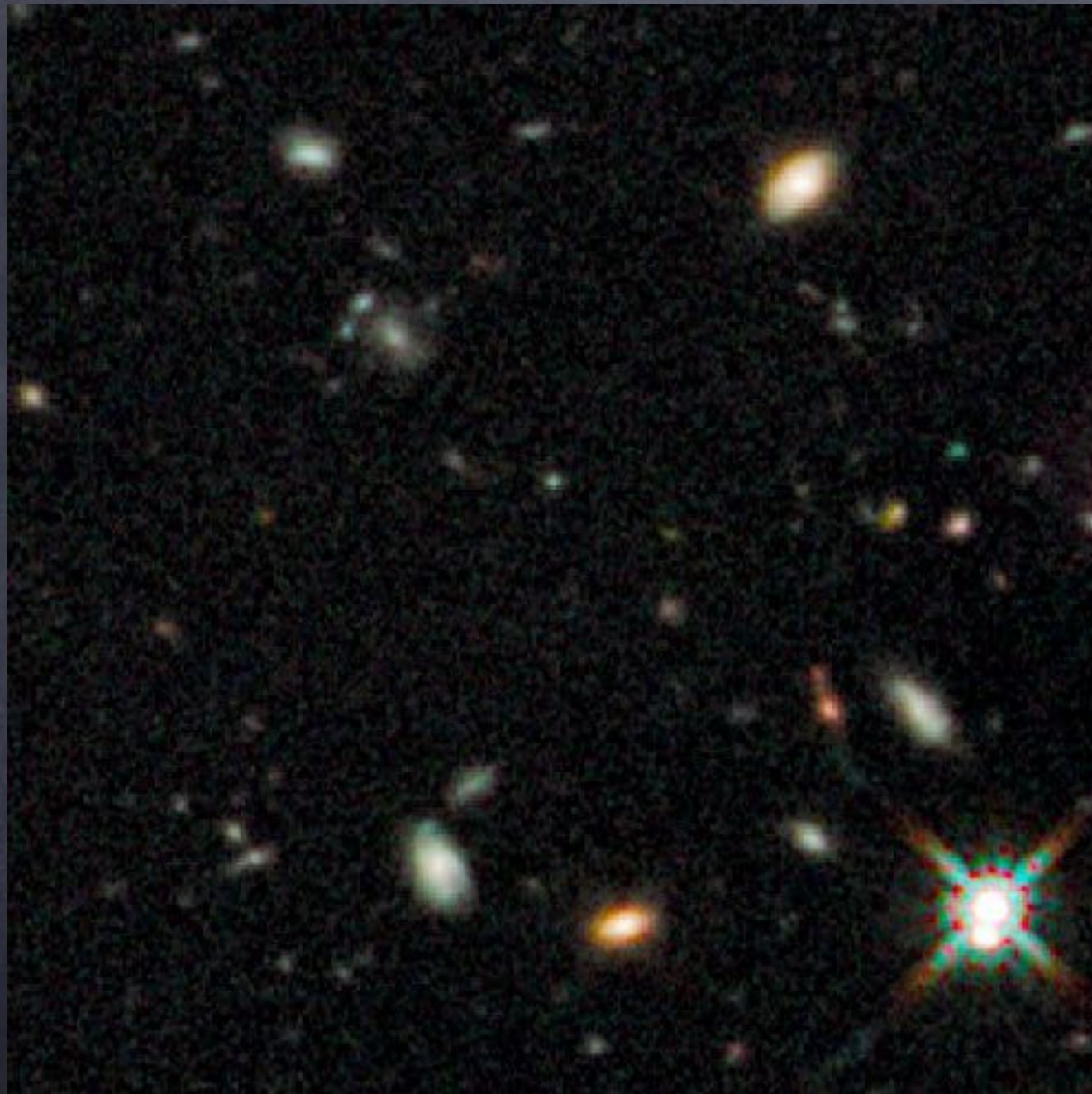

# Why do we need a better resolution?

2) Reduce the background --> improve S/N

The sky is not dark: background is  $10^2$ - $10^4$  times brighter than objects. Shot-noise (Poisson) dominates the S/N

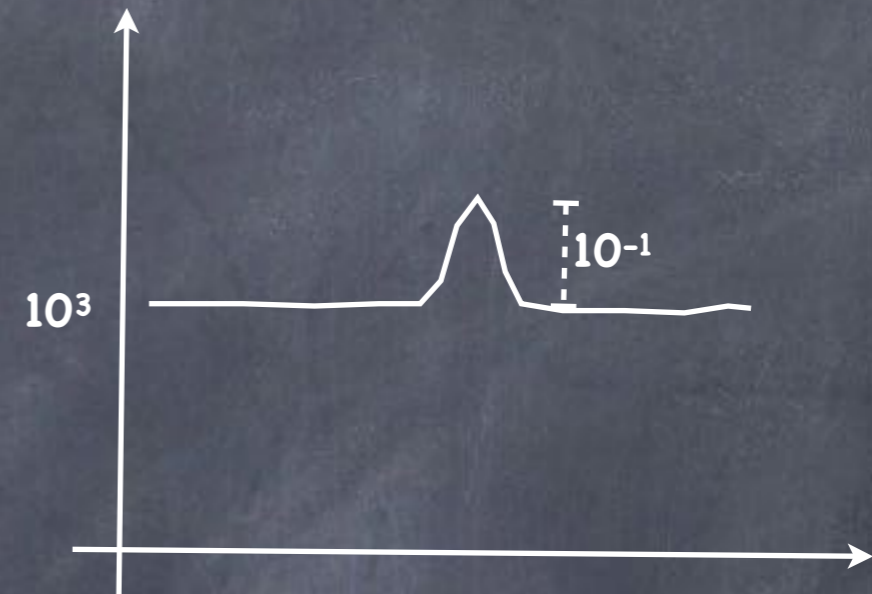
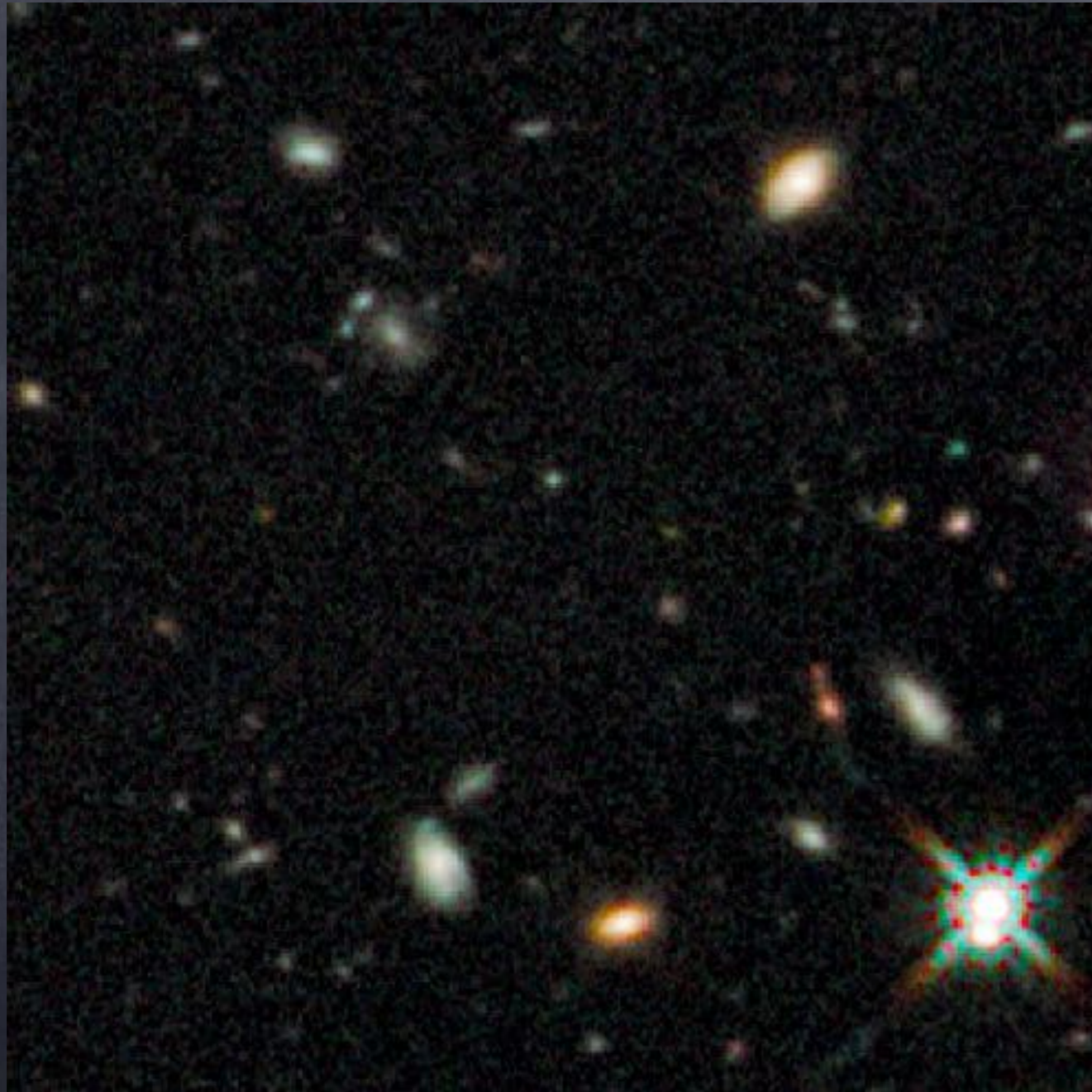

# Instruments for optical/IR telescopes

## Common focal stations

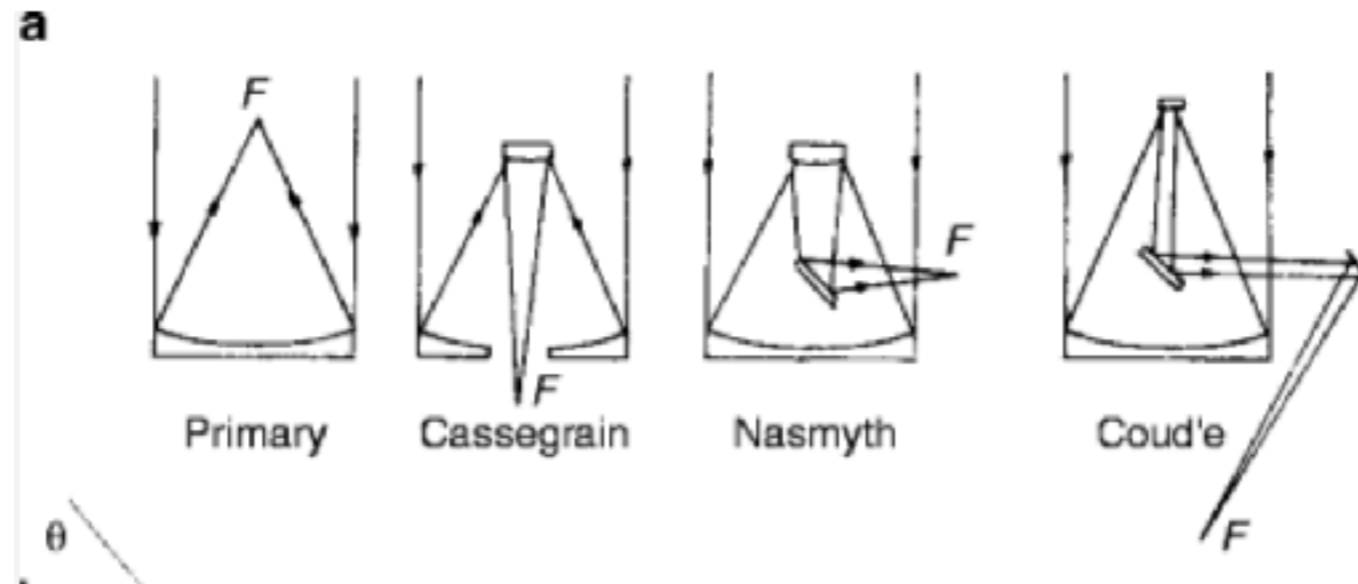

## Instrument types

- 1) Imagers
- 2) Long/Multi Slit Spectrographs
- 3) Fiber-fed spectrograph
- 4) Integral Field Units (IFU)

# I) Imagers

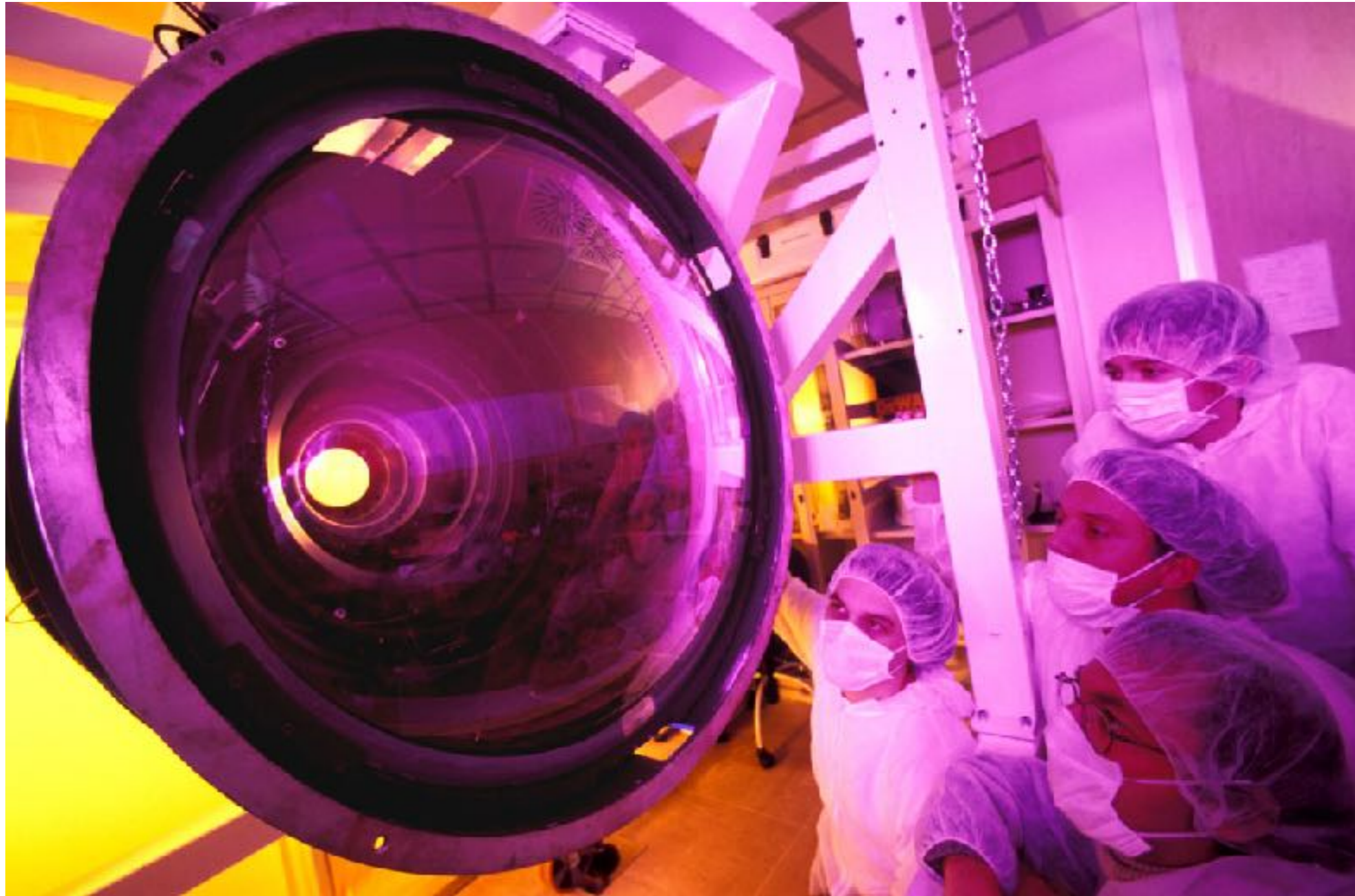

# I) Imagers

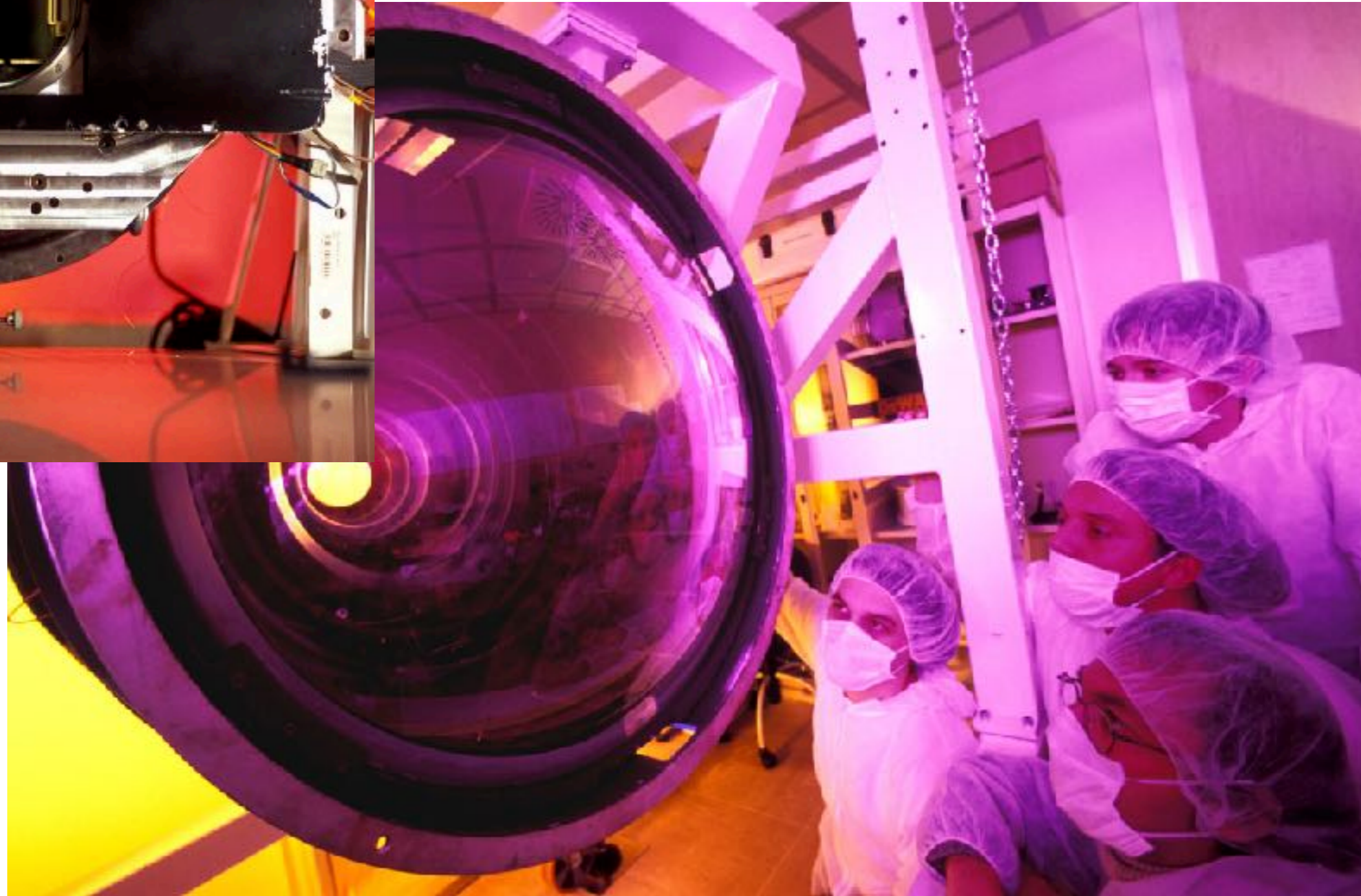
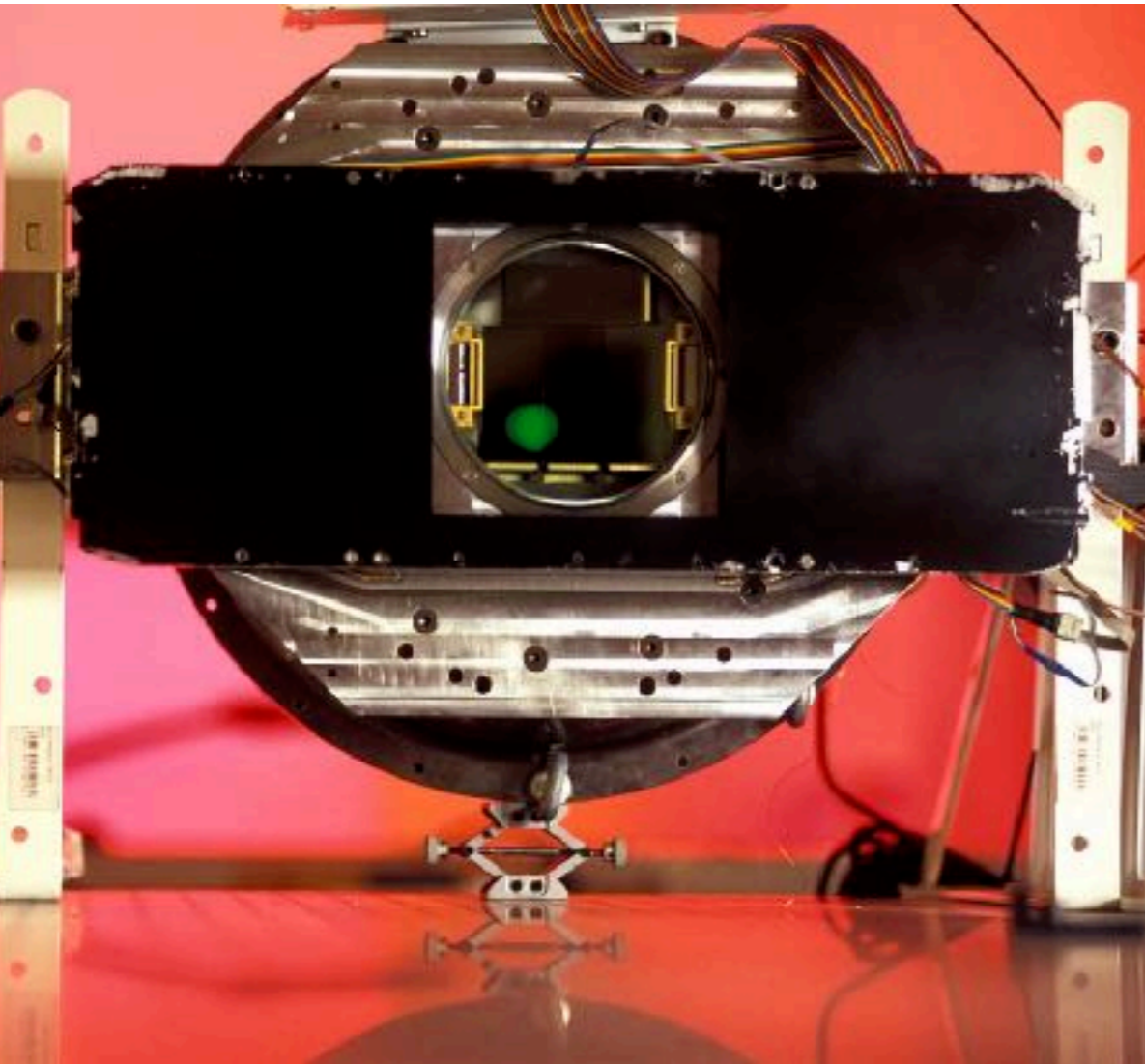

Imagers at Cassegrain or Nasmyth foci are usually more compact.

NICS@TNG

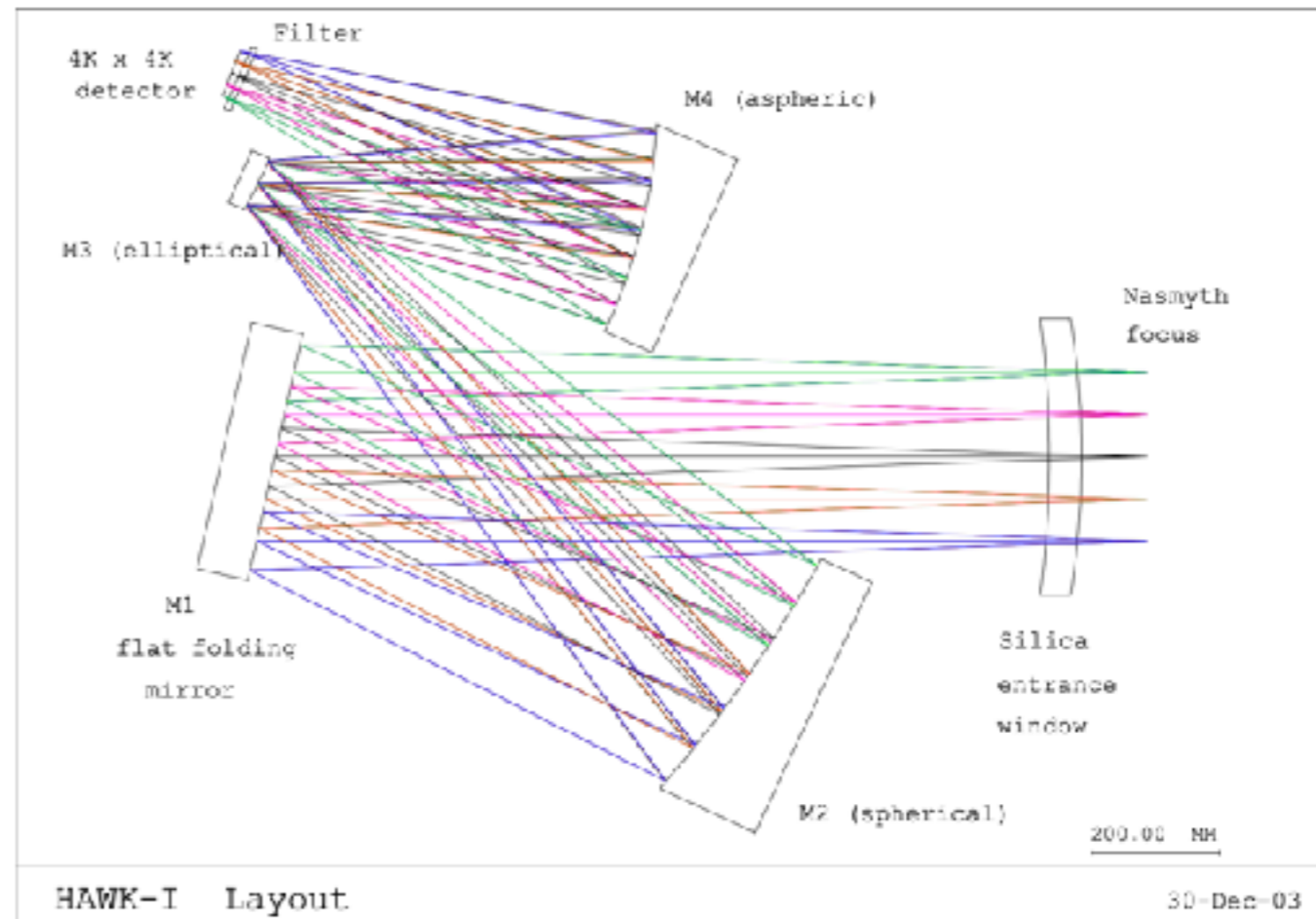

HAWK-I

High Acuity Wide-field K-band Imager

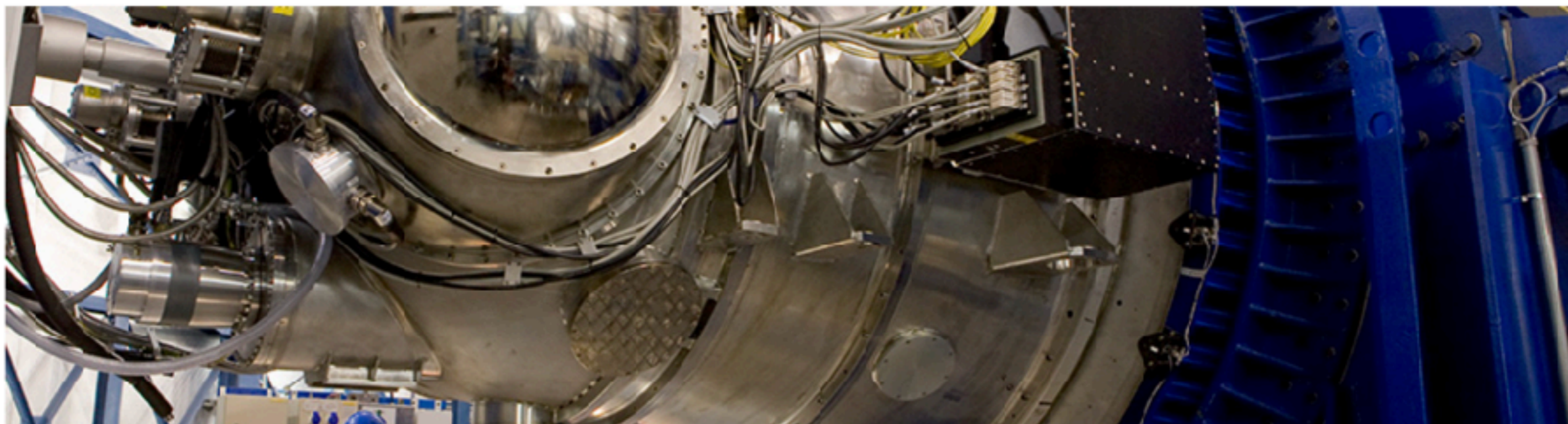

European  
Southern  
Observatory



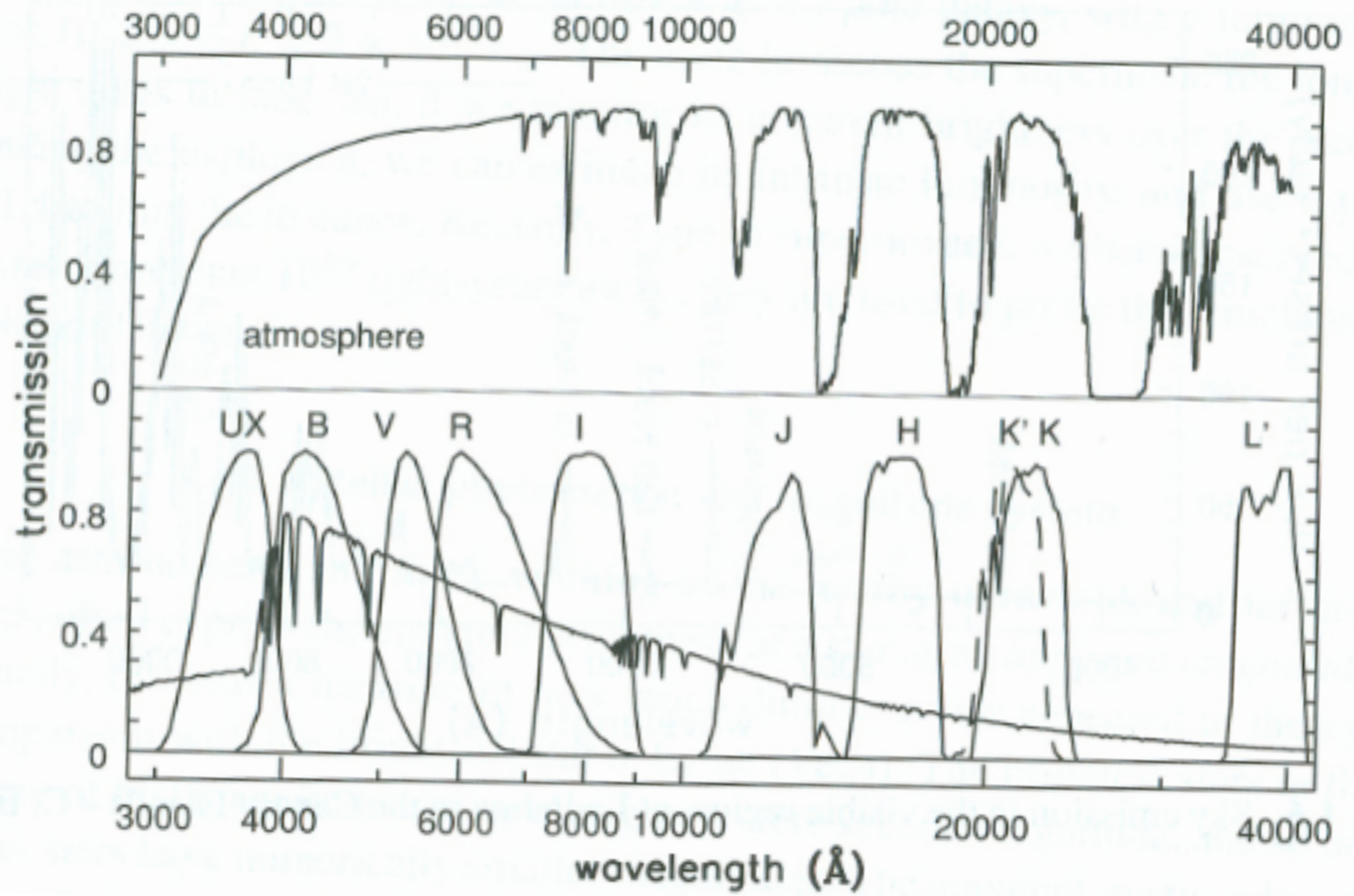

# Filtri astronomici

UBVRIZ BESSEL

(FORS-VLT)

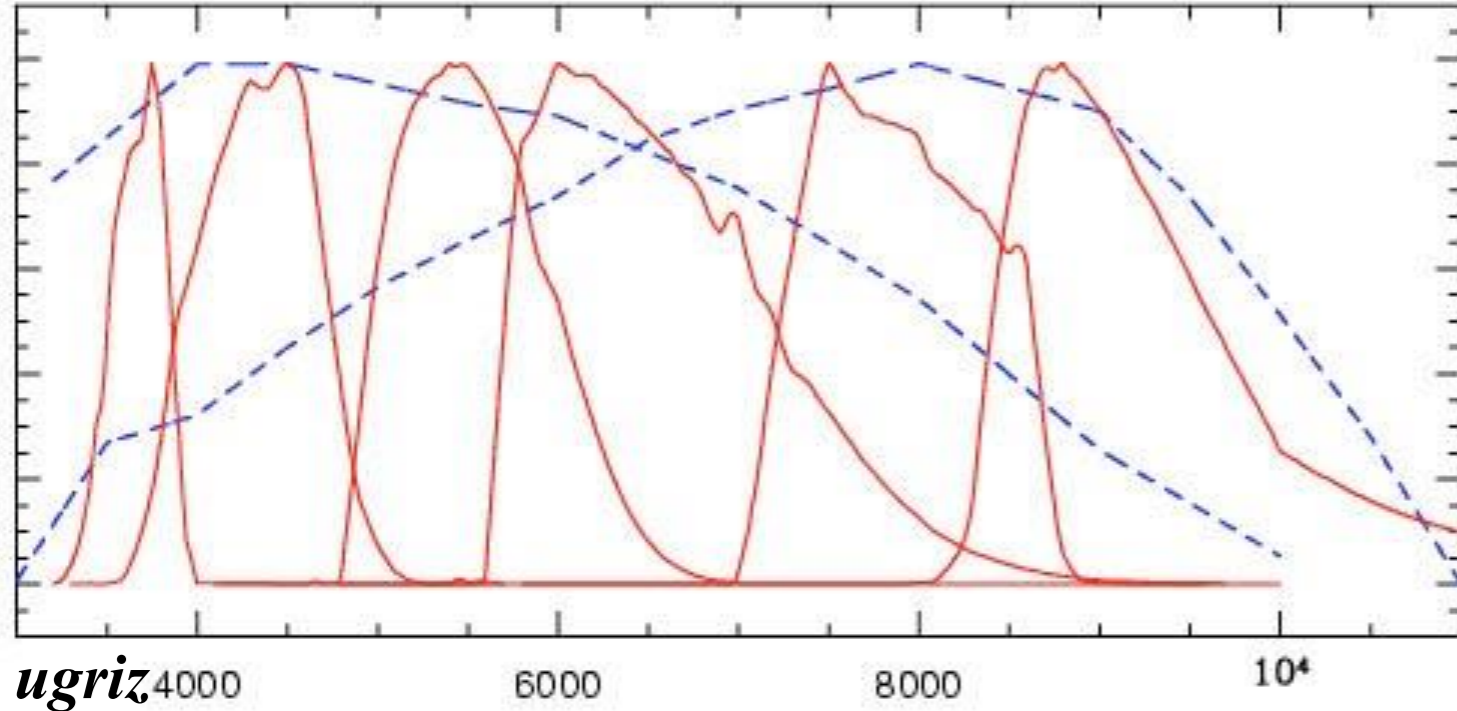

Sloan Survey

CFHT Legacy Survey

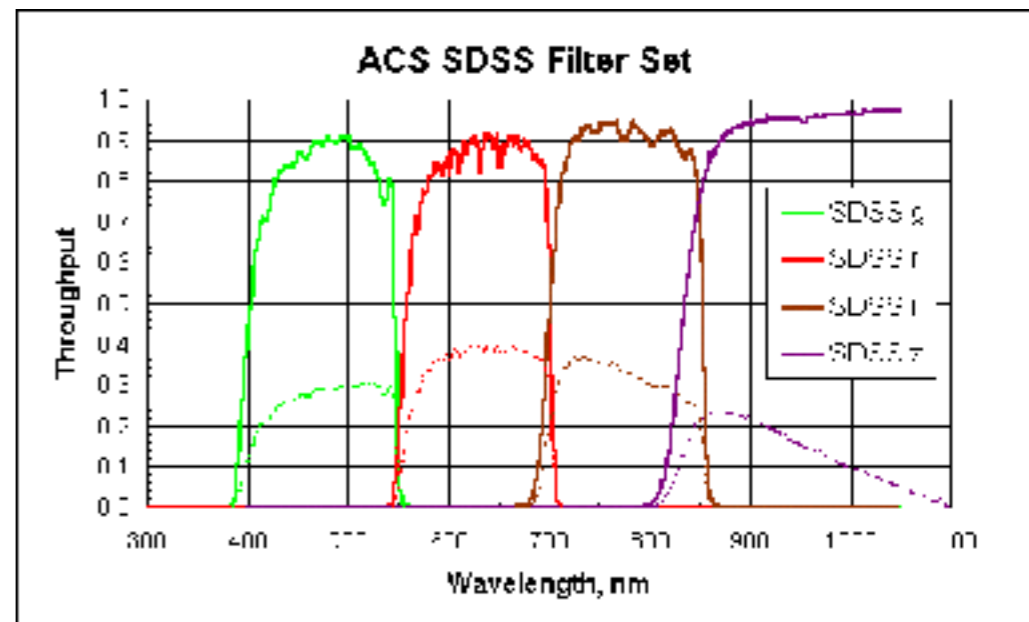
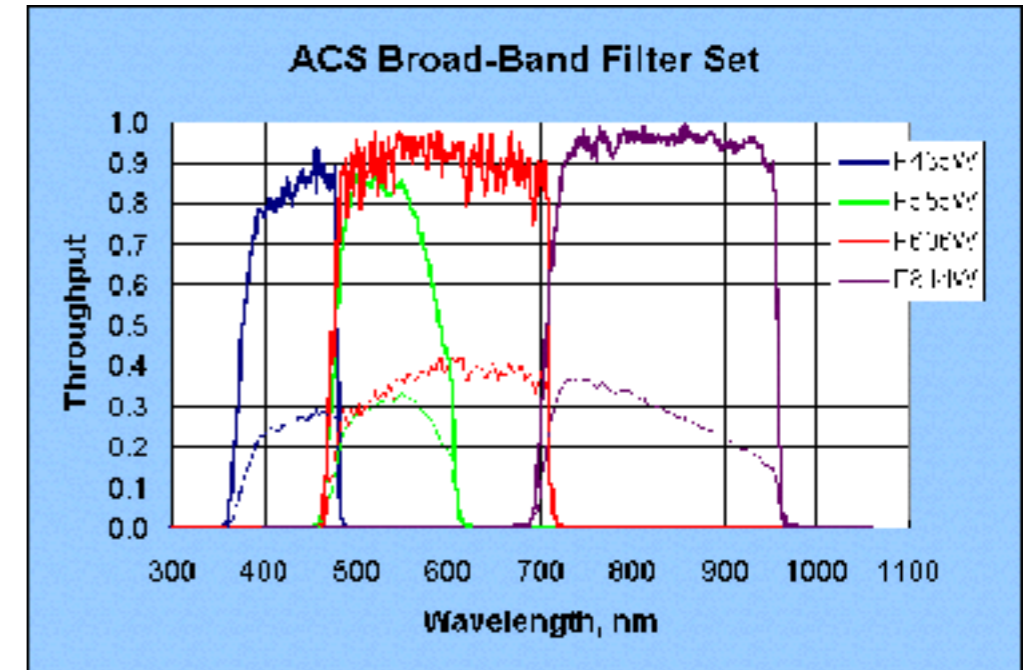
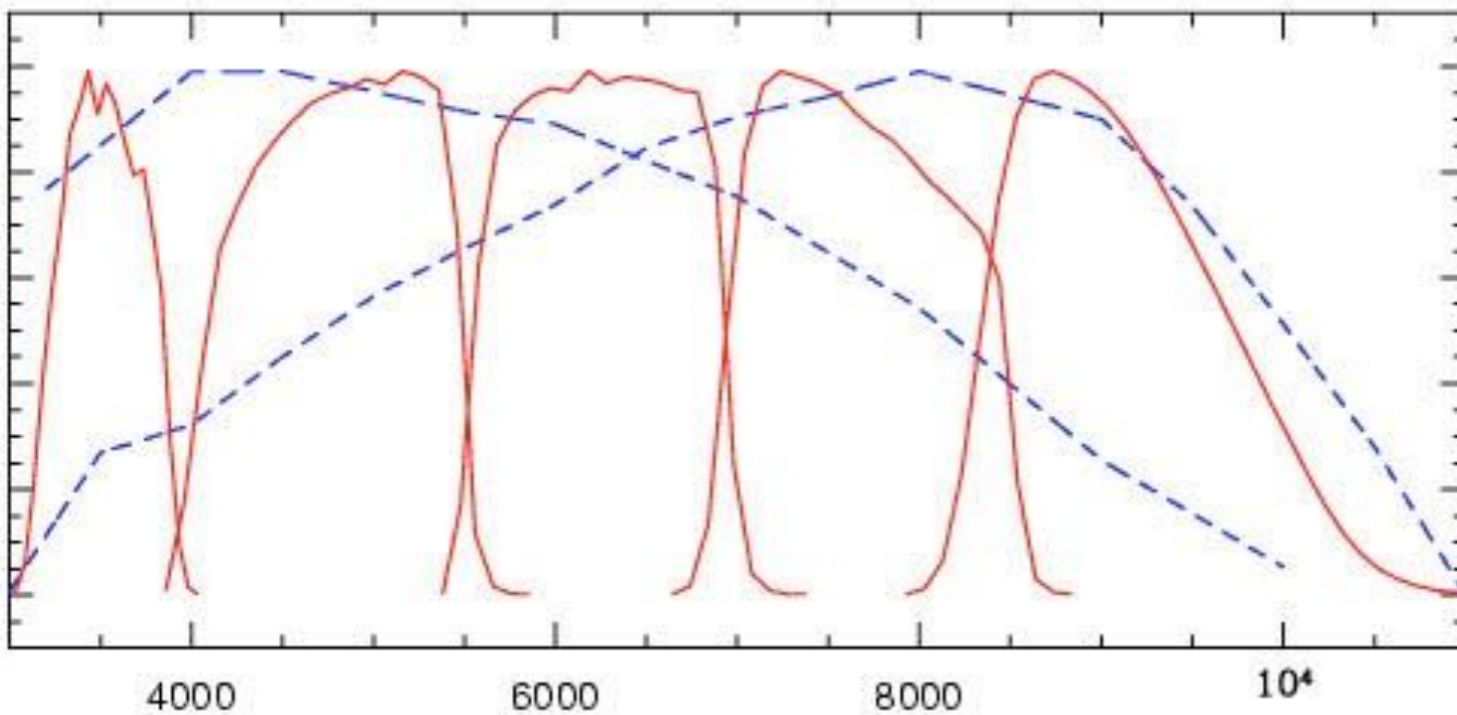

# Filtri astronomici

## NIRCam Filters

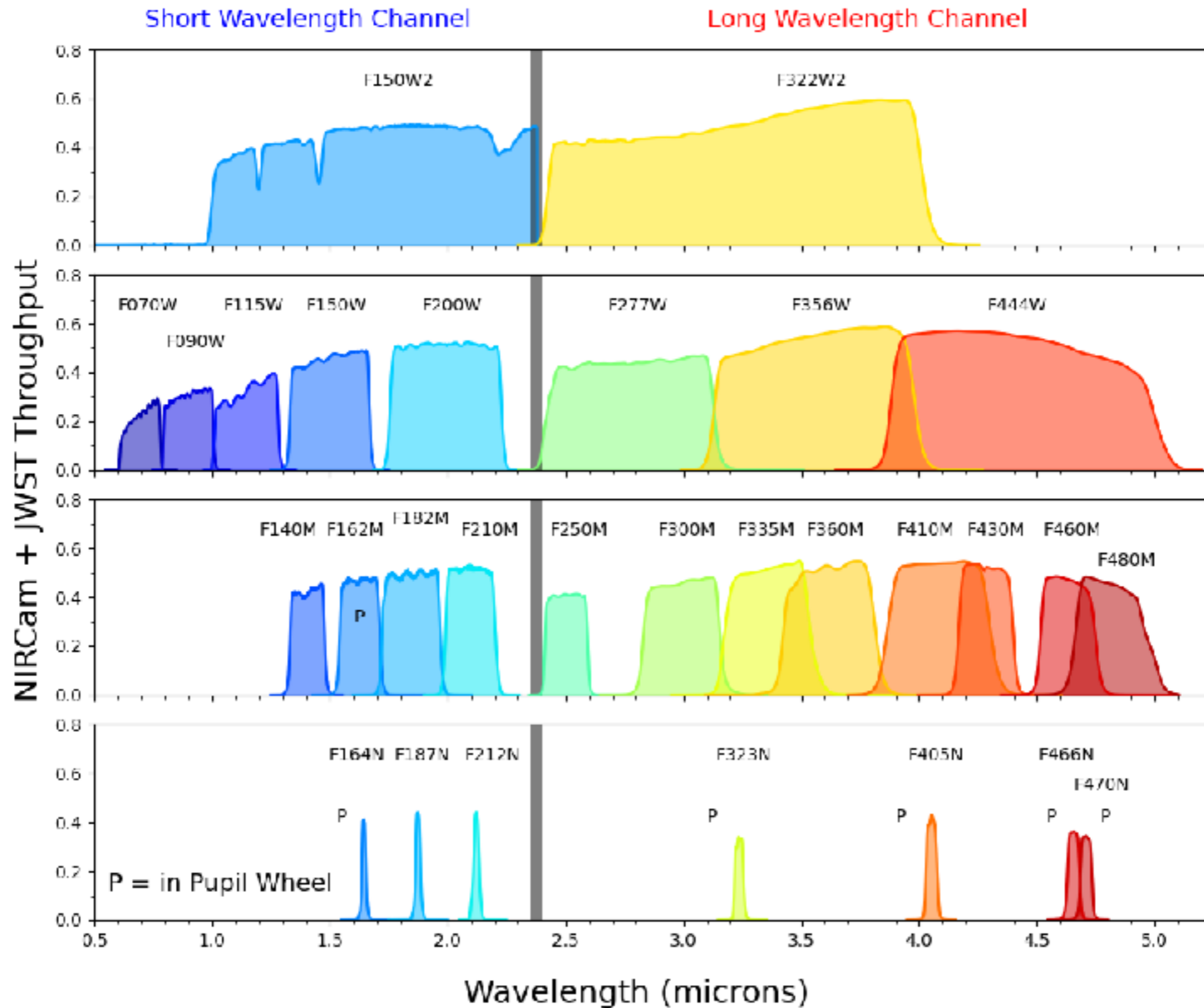

# Come si analizzano le immagini?

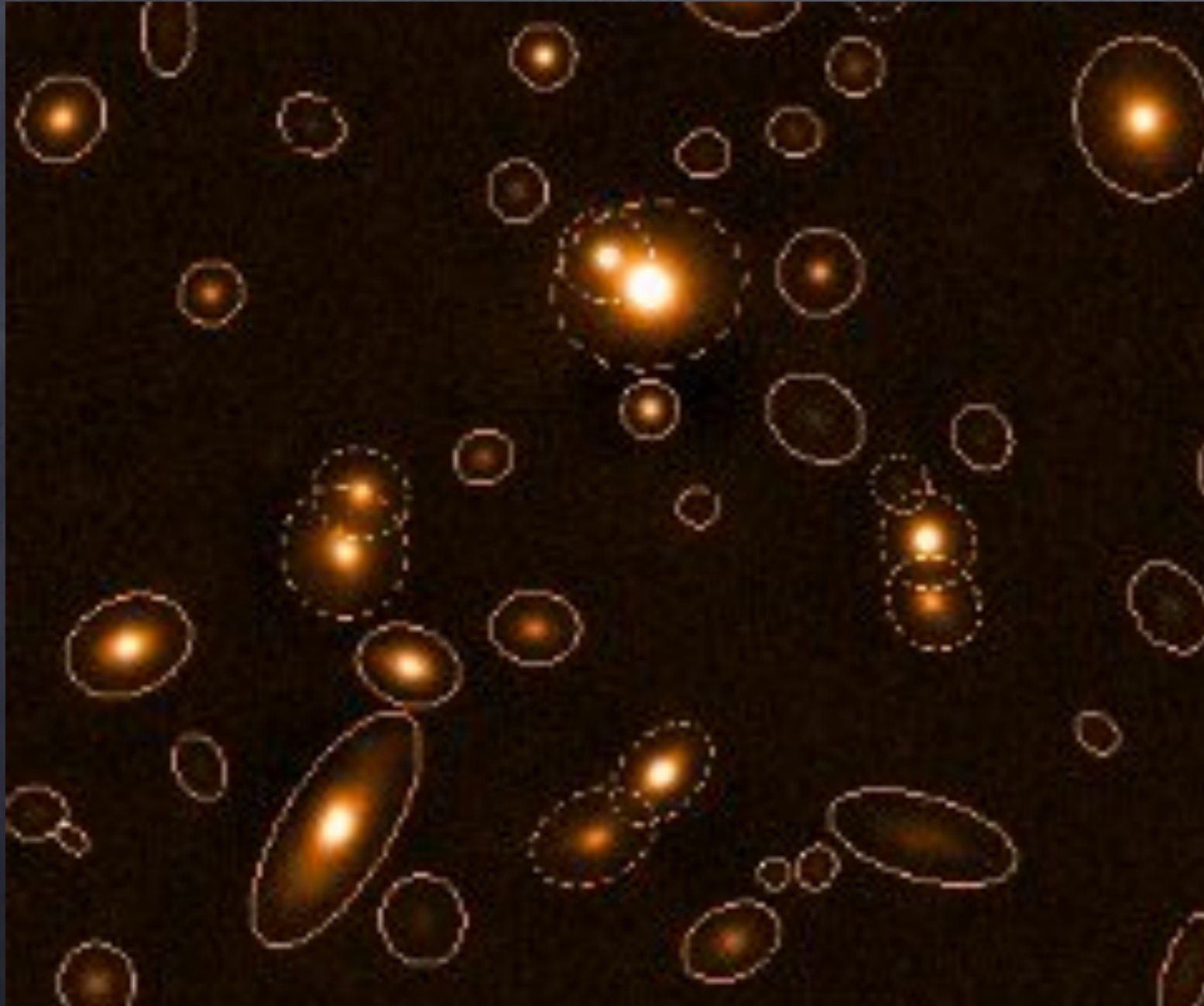

Le immagini vengono analizzate con software specifici che individuano gli oggetti e ne misurano:

- 1) il flusso nelle varie bande
- 2) parametri che descrivono la forma ("morfologia")

Sebbene concettualmente semplice, è difficile ottenere accuratezze superiori a qualche %, e rimangono effetti sistematici difficili da trattare, specie nel caso di galassie.

## 2) Spettrografi

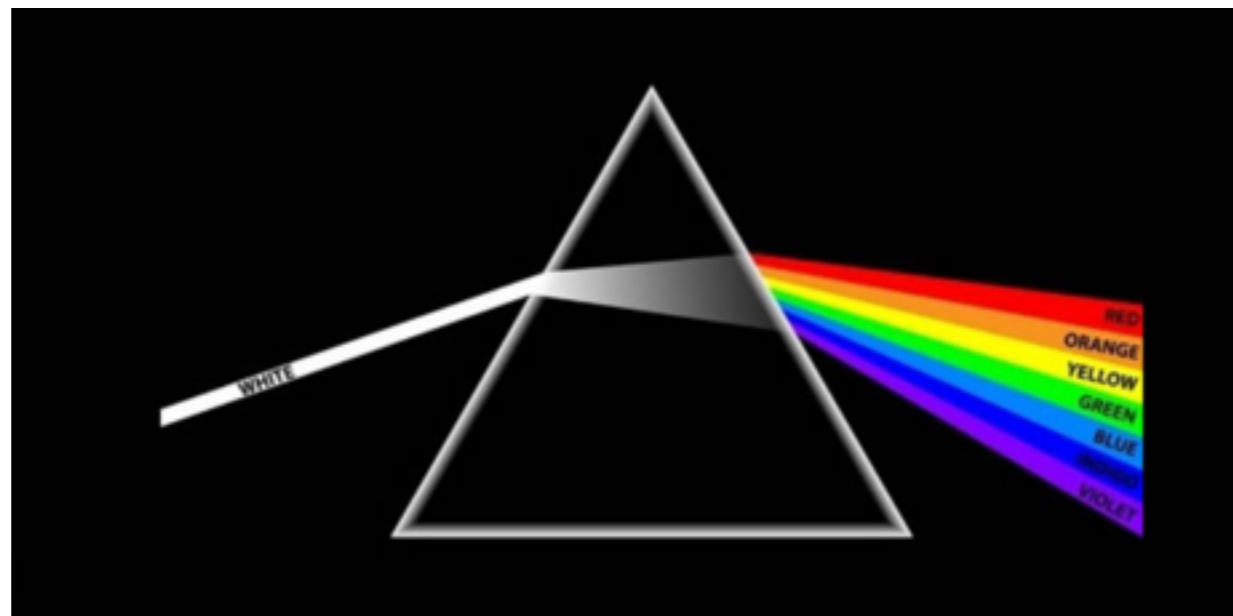

Spectrographs use a “dispersing element” to split wavelengths

Prism  
(refractive element)

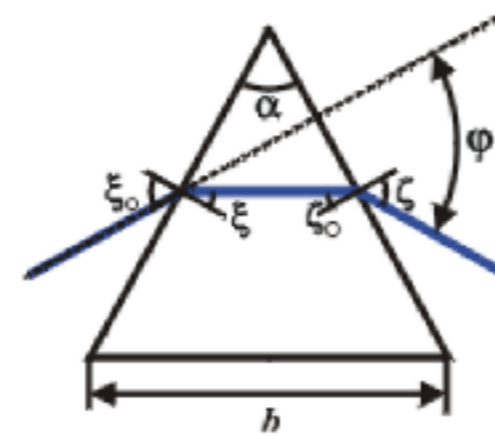

Grating  
(diffractive element)

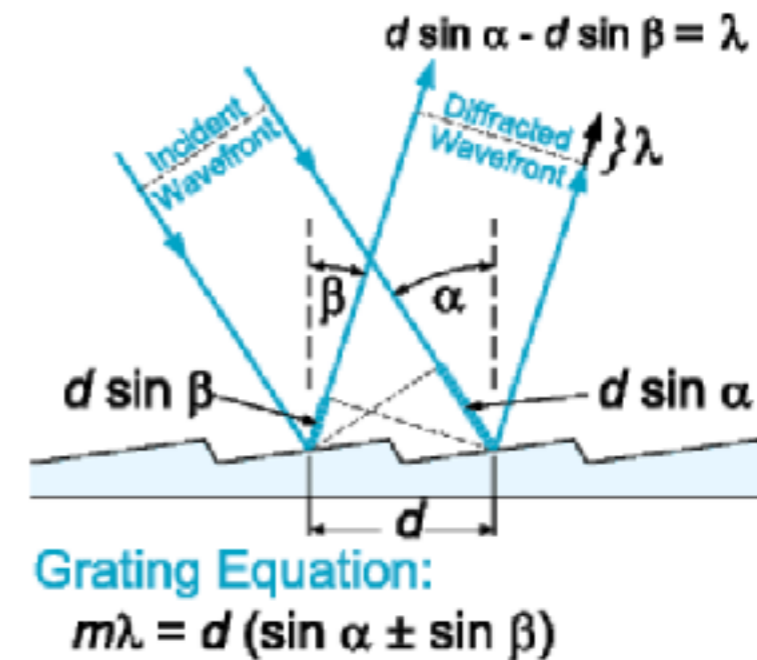

Grism  
(prism+grating)

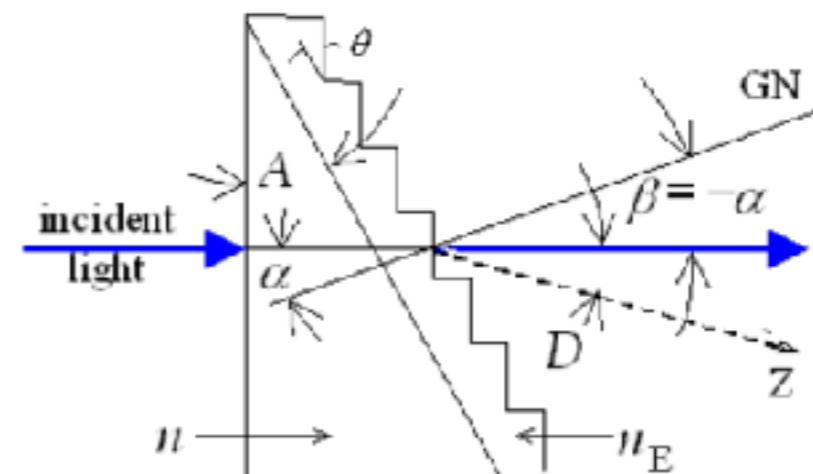

# Grating

$$m\lambda = d(\sin \alpha + \sin \beta)$$

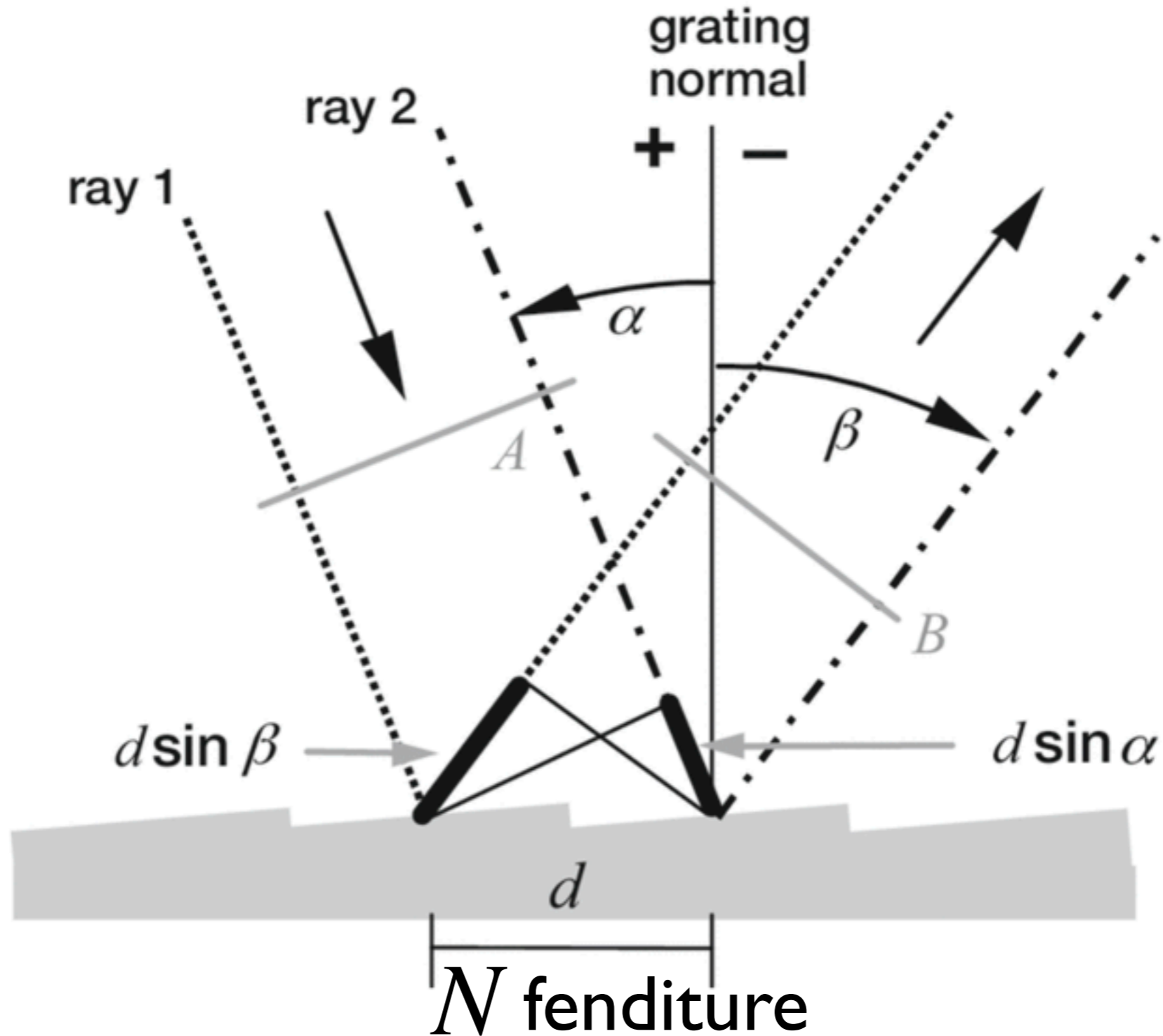

### 4.3.1 Grating dispersion

Given the grating equation:

$$m \lambda = d(\sin \alpha \pm \sin \beta)$$

and the fact that the angle of incidence,  $\alpha$ , is constant, then differentiating the grating equation gives the **angular dispersion** of the grating:

$$\frac{\Delta \beta}{\Delta \lambda} = \frac{m}{d \cos \beta}$$

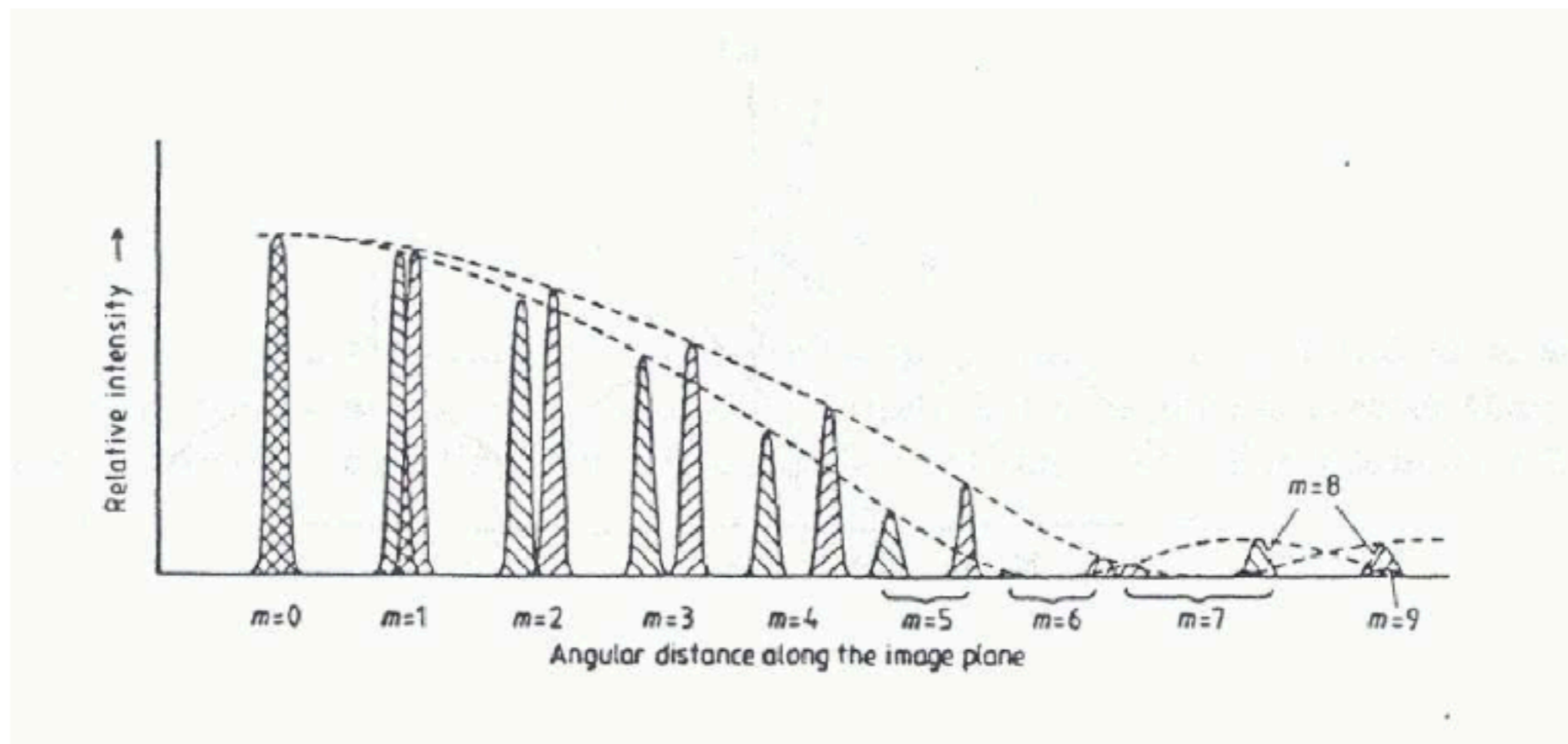



# Relazione di dispersione

$$m\lambda = d(\sin \alpha + \sin \beta)$$

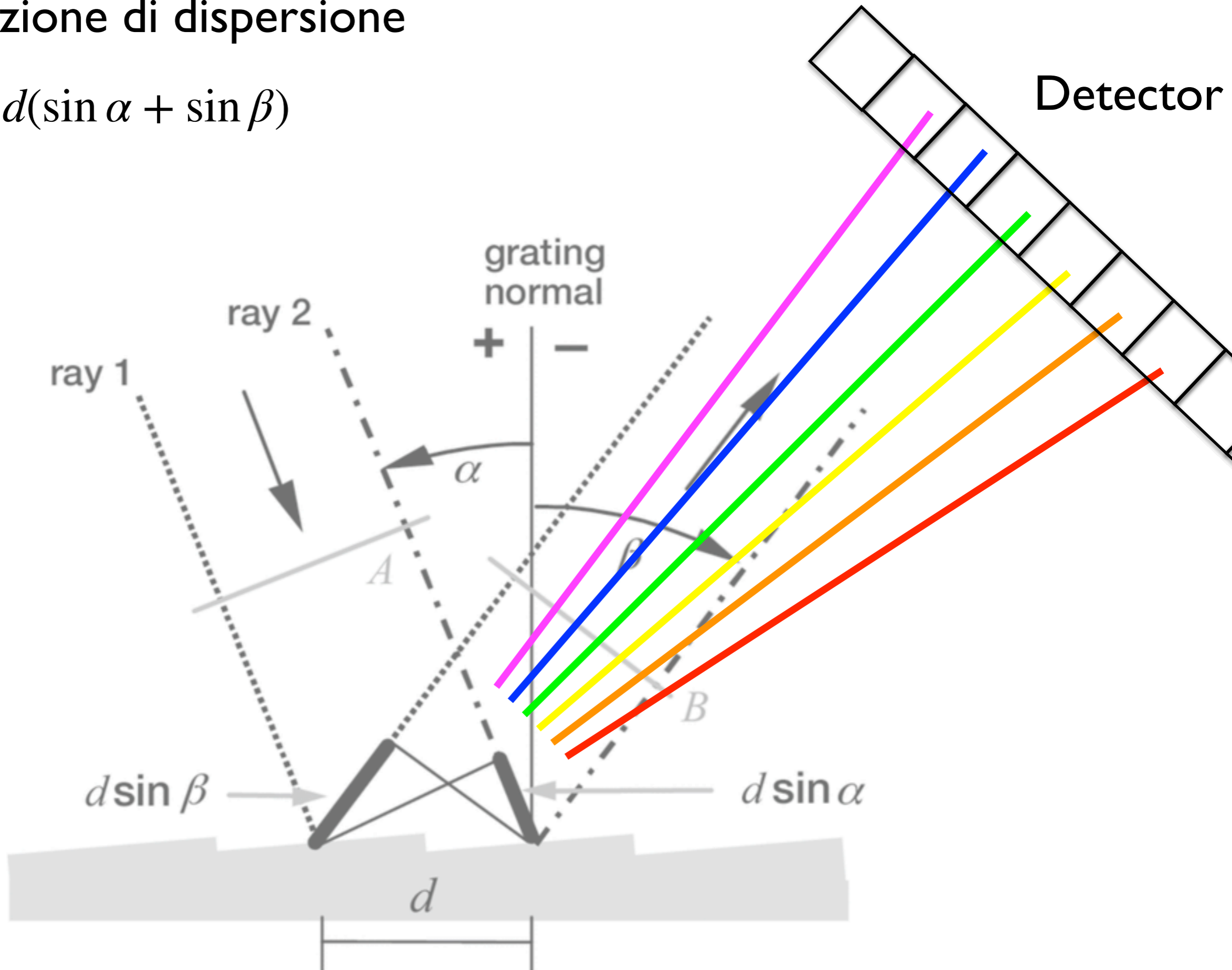

### 4.3.1 Grating dispersion

Given the grating equation:

$$m \lambda = d(\sin \alpha \pm \sin \beta)$$

and the fact that the angle of incidence,  $\alpha$ , is constant, then differentiating the grating equation gives the **angular dispersion** of the grating:

$$\frac{\Delta\beta}{\Delta\lambda} = \frac{m}{d \cos \beta}$$

This expression is fundamental to understanding how gratings work and we will return to it. Clearly, the dispersion is

- proportional to the order,  $m$ ; the second order has twice the dispersion of the first.
- inversely proportional to the line separation,  $d$ ; the more lines/mm, the greater the dispersion.

$$R = \frac{\lambda}{\Delta\lambda} = mN \propto \frac{m}{d} \quad \text{Risoluzione}$$

$$m\lambda = d(\sin \alpha + \sin \beta) \quad \text{Relazione di dispersione}$$

$$R = \frac{\lambda}{\Delta\lambda} = mN \propto \frac{m}{d} \quad \text{Risoluzione}$$

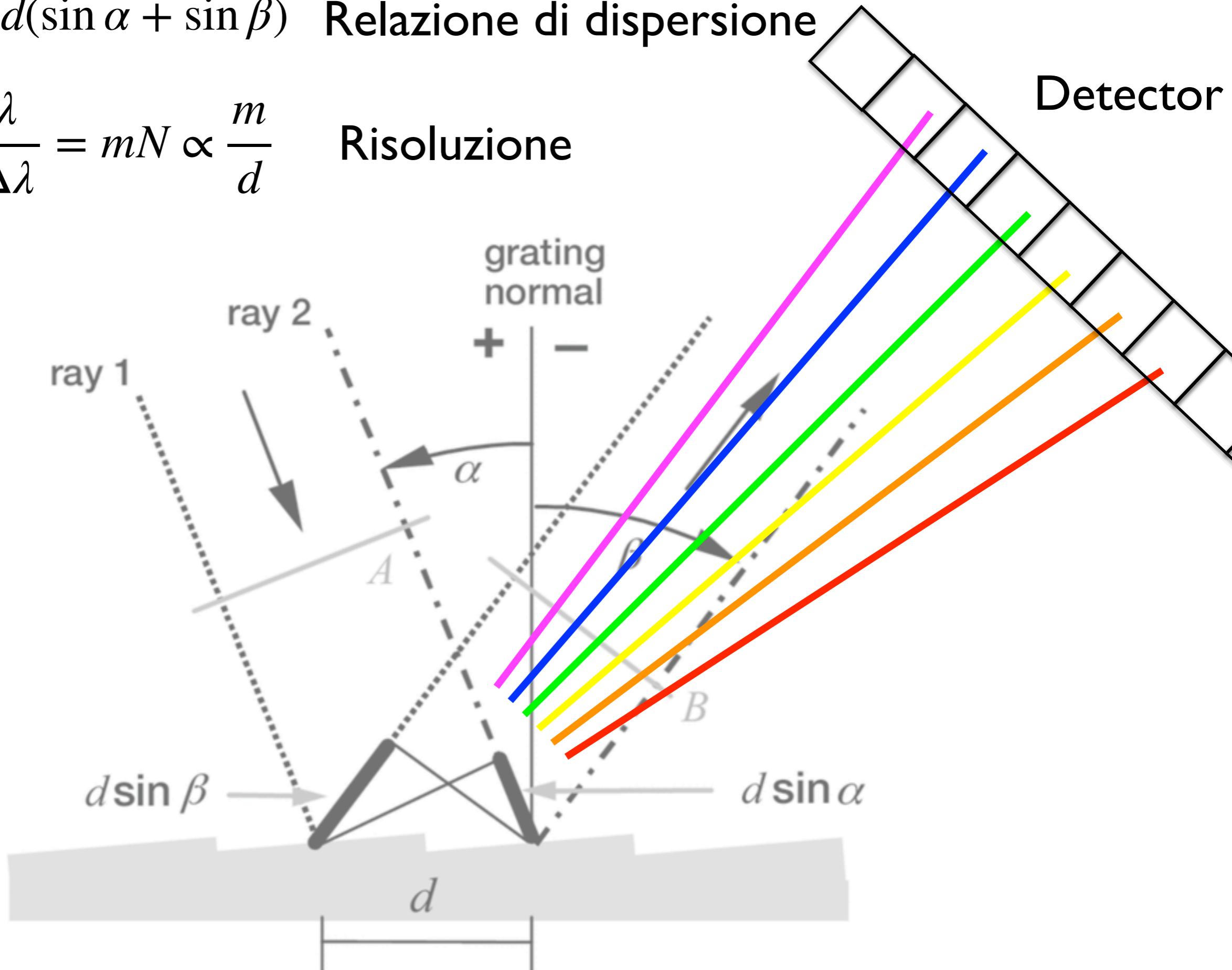

$$\text{Resolution } R = \lambda / \Delta \lambda$$

Prism  
(refractive element)

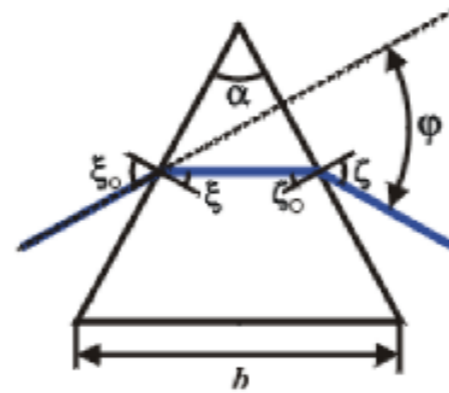

$$R \sim 100-200$$

Grating  
(diffractive element)

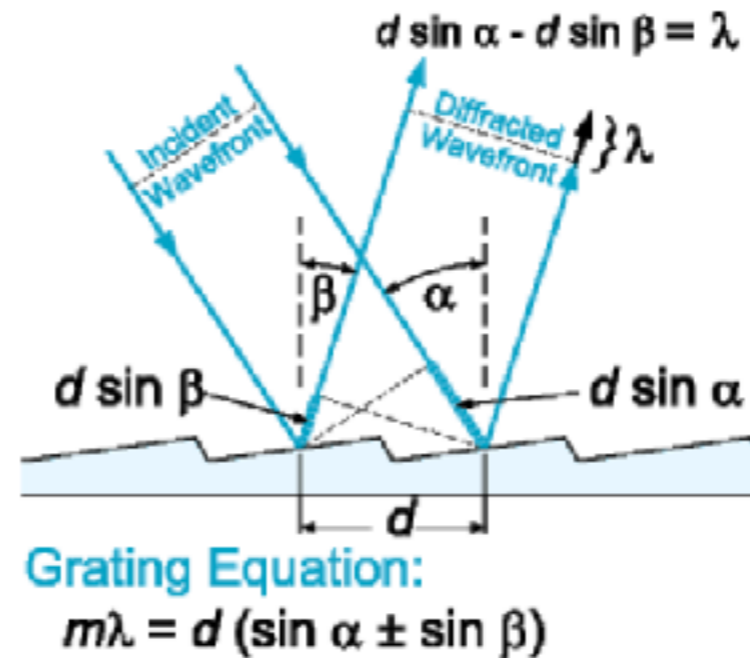

$$R \sim 1.000-20.000$$

$$R \sim 200.000$$

Grism  
(prism+grating)

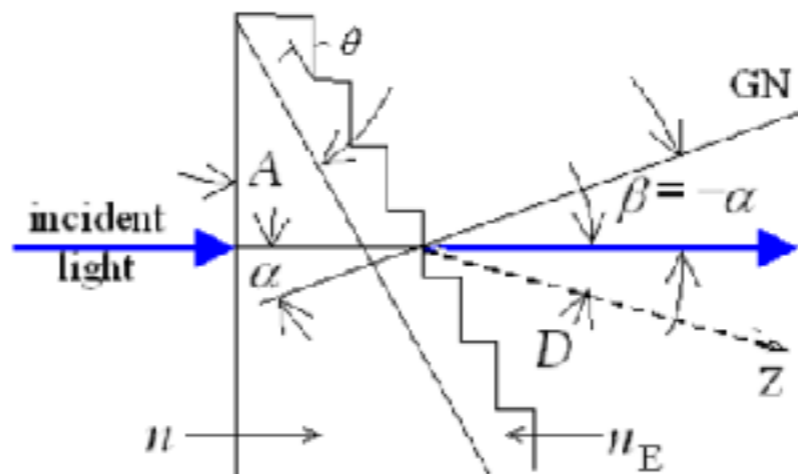

$$R \sim 1.000-5.000$$

# Multi-object spectroscopy.

“Slits” are inserted to take the spectra only of selected targets

Scene on the sky

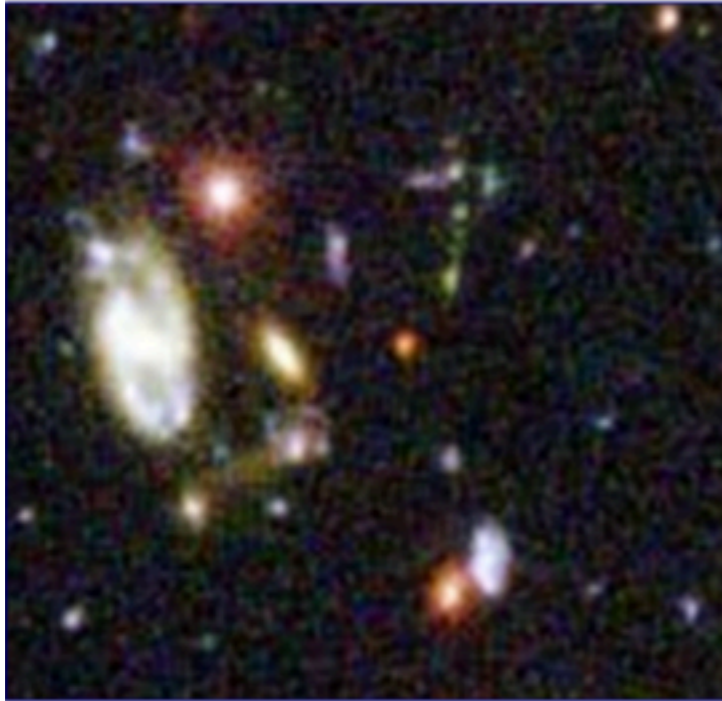

Selection of Objects

Scene on the shutter mask



Spectra on the detector

Selection of Objects

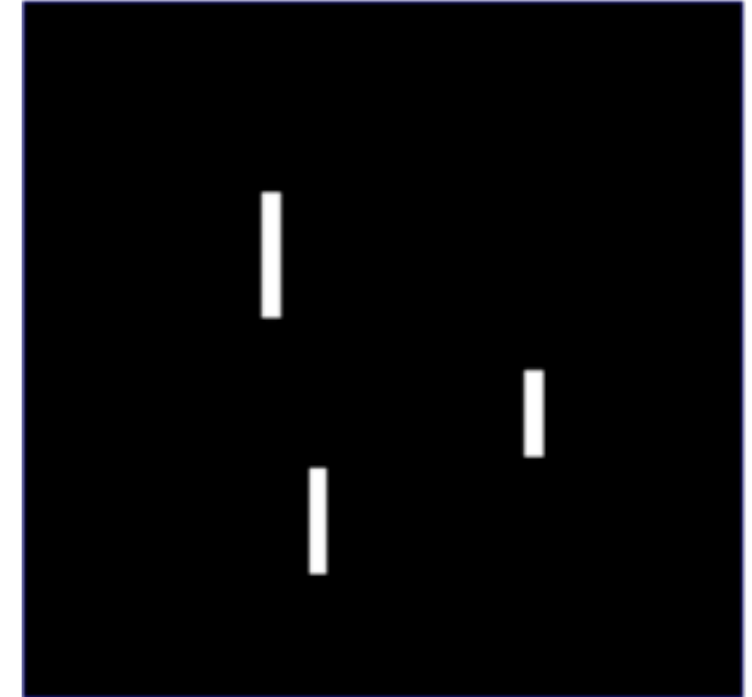



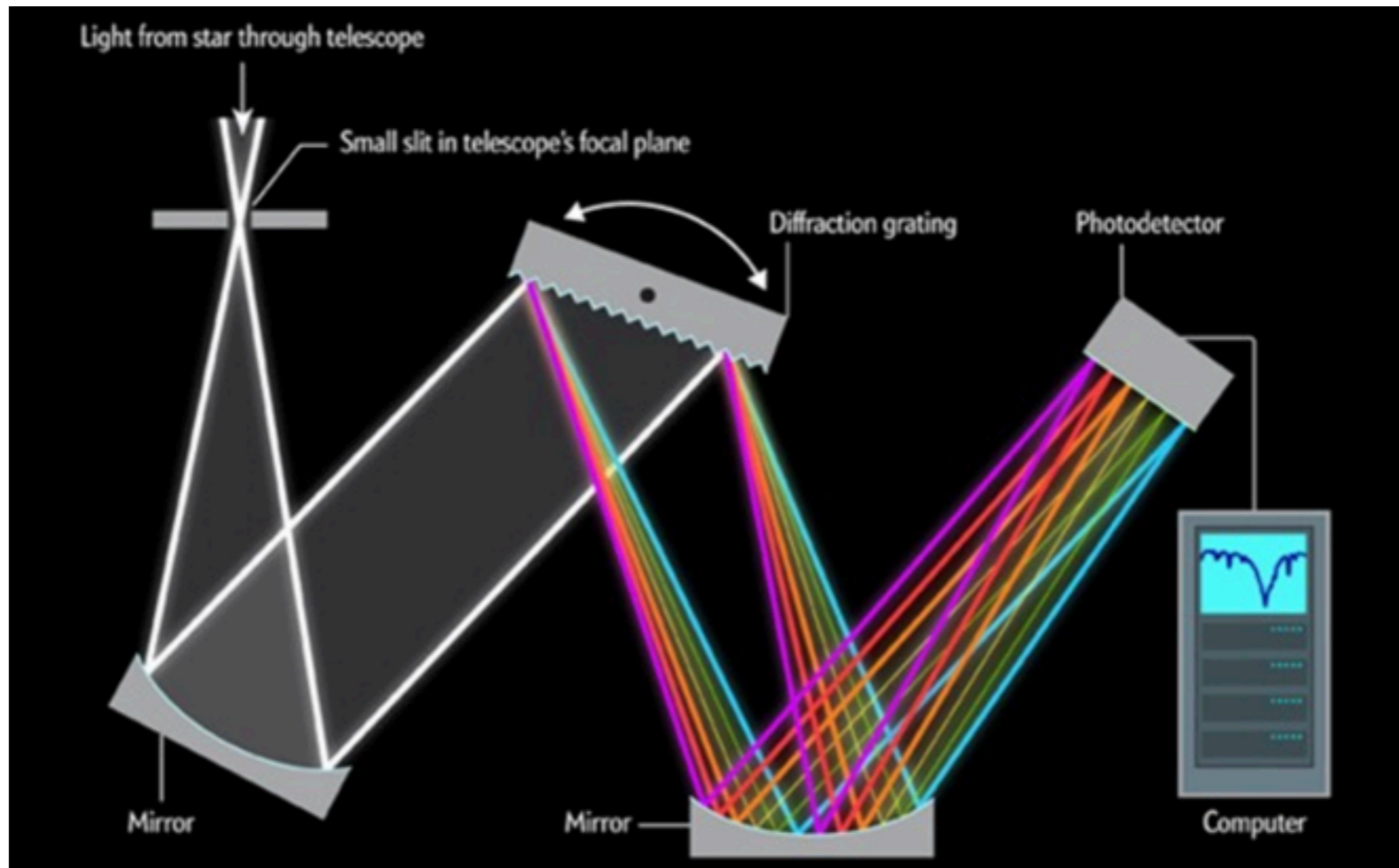

# Multi-object spectroscopy.

“Slits” are inserted to take the spectra only of selected targets

Scene on the sky



Scene on the shutter mask



Selection of Objects

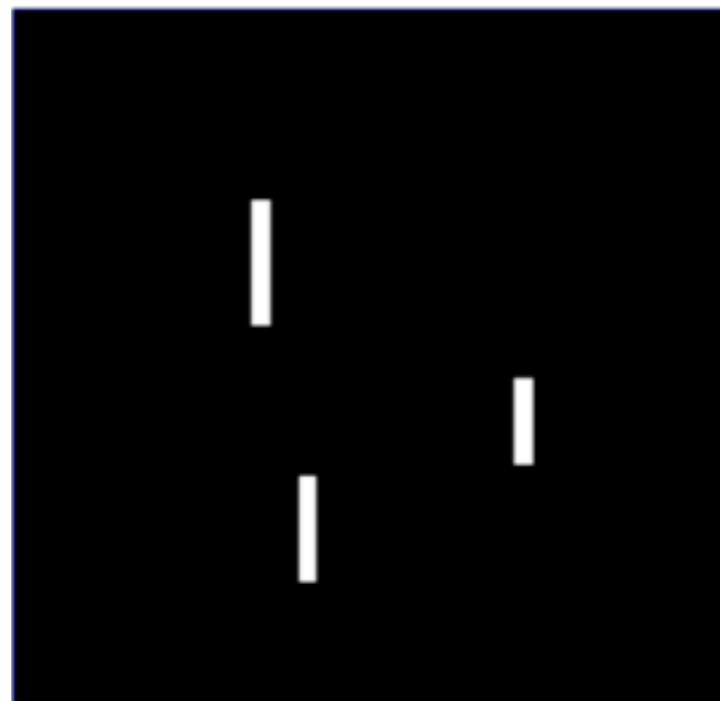

Spectra on the detector

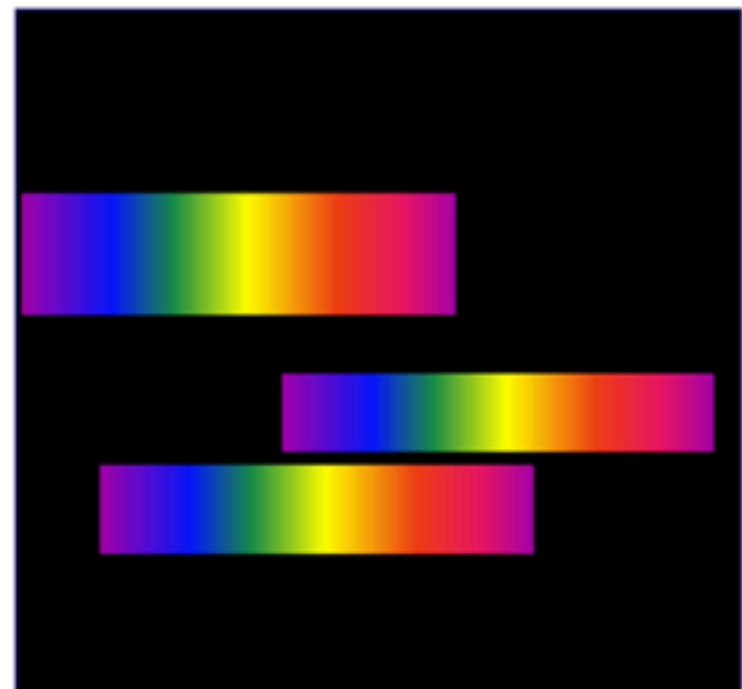

*DOLORES@TNG*



# Multi-object spectroscopy (MOS).

“Slits” are inserted to take the spectra only of selected targets

## Advantages:

- Strongly reduces the background
- Observes only objects you are interested to.
- 1D spatial info is preserved

## Disadvantages:

- relatively few objects (~50)
- may miss part of the light if the object is larger than the slit
- spectrograph may be unstable (rotation)

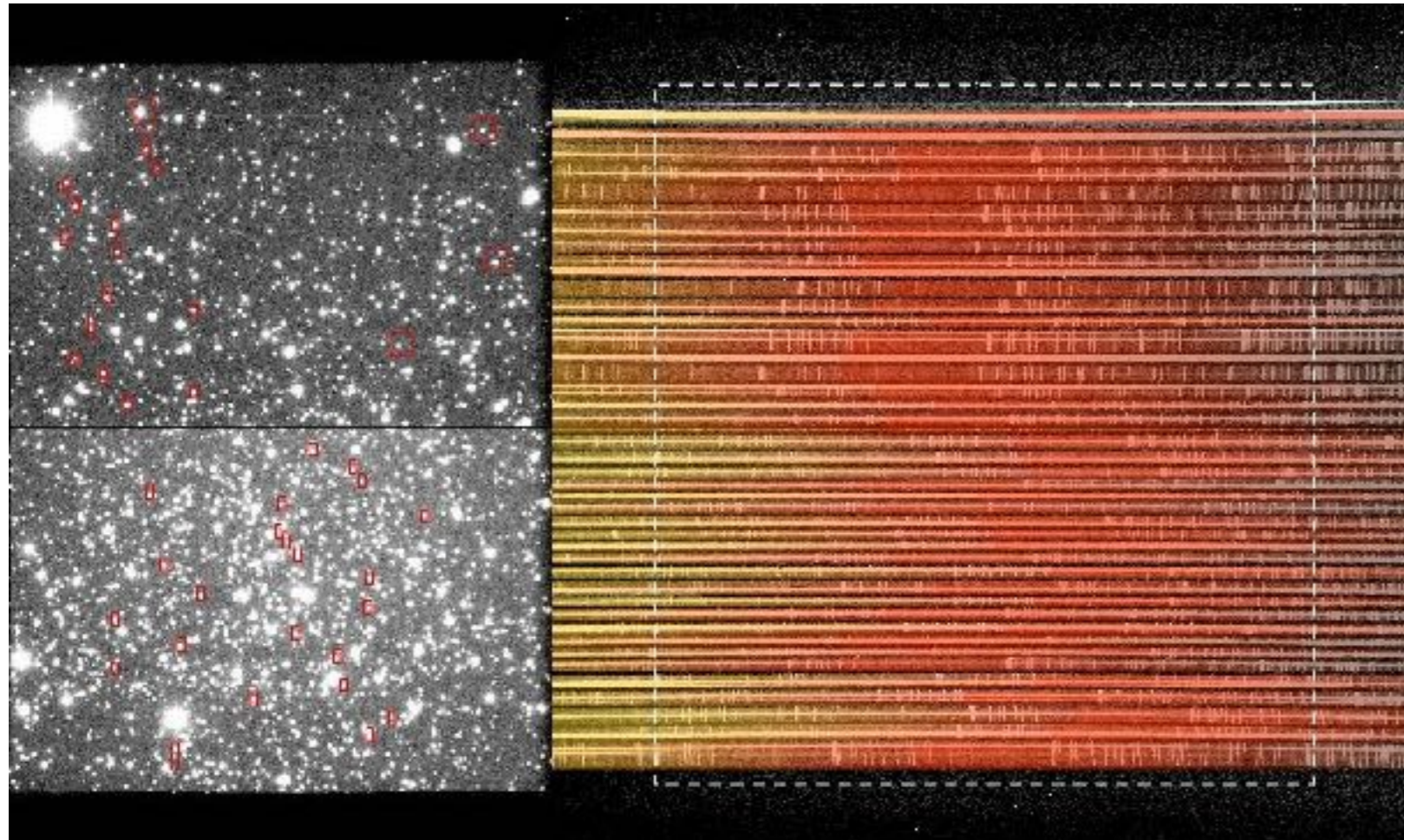

# Fiber-fed spectroscopy.

Head of optical fibres are placed (by robots) on selected targets

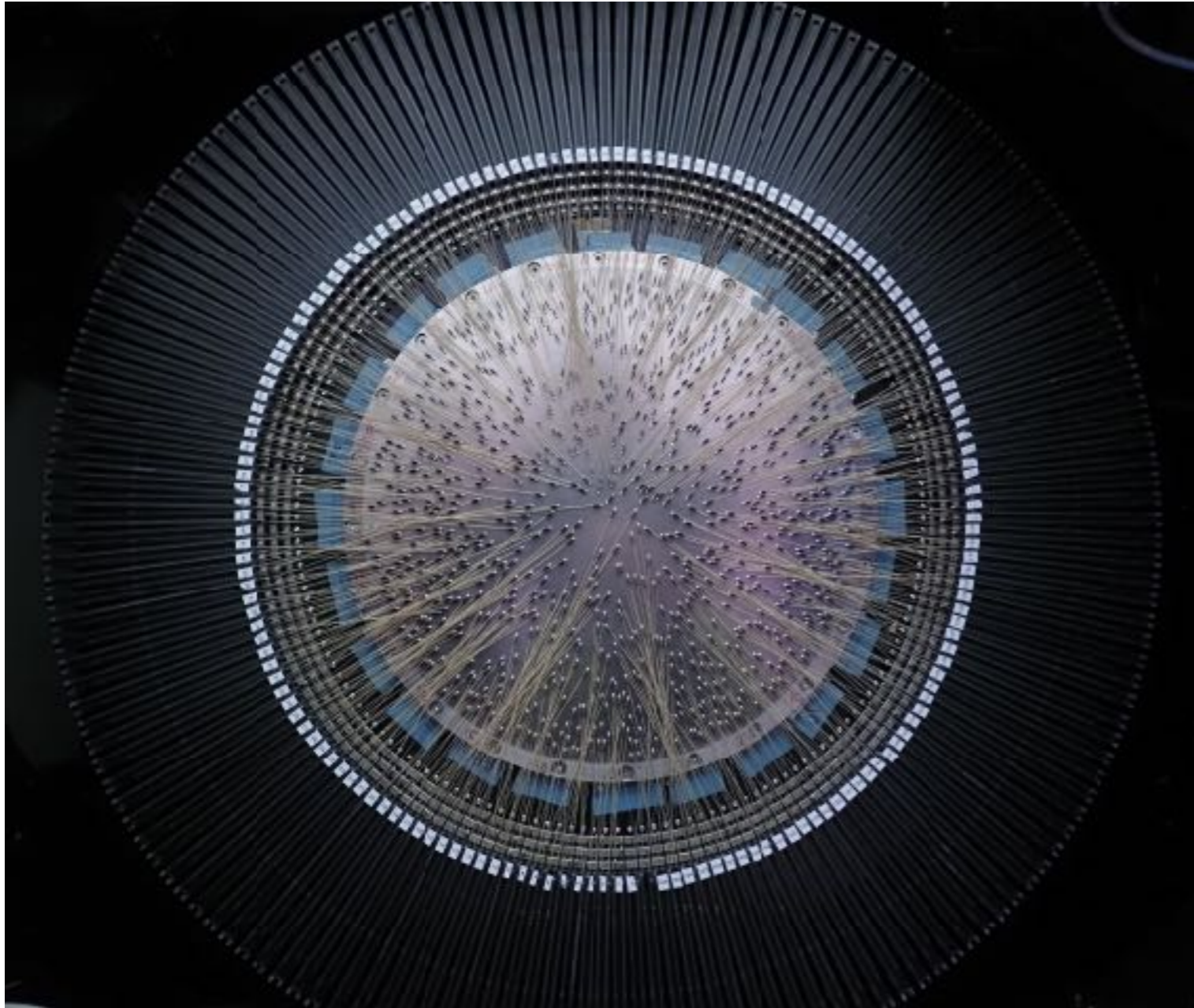

## Advantages:

- Strongly reduces the background
- Observes only objects you are interested to.
- Many more objects than MOS (~1000).
- Fibers allow you to build a large spectrograph in a stable environment

## Disadvantages:

- more difficult than MOS to measure the bckg
- may miss part of the light if the object is larger than the fibre head
- spatial info is lost

Problem: you may want both high resolution  $R$  and wide wavelength coverage.

The resulting spectrum will be very long.

Solution: double dispersion.

X-shooter



HARPS@TNG  
GIANO@TNG

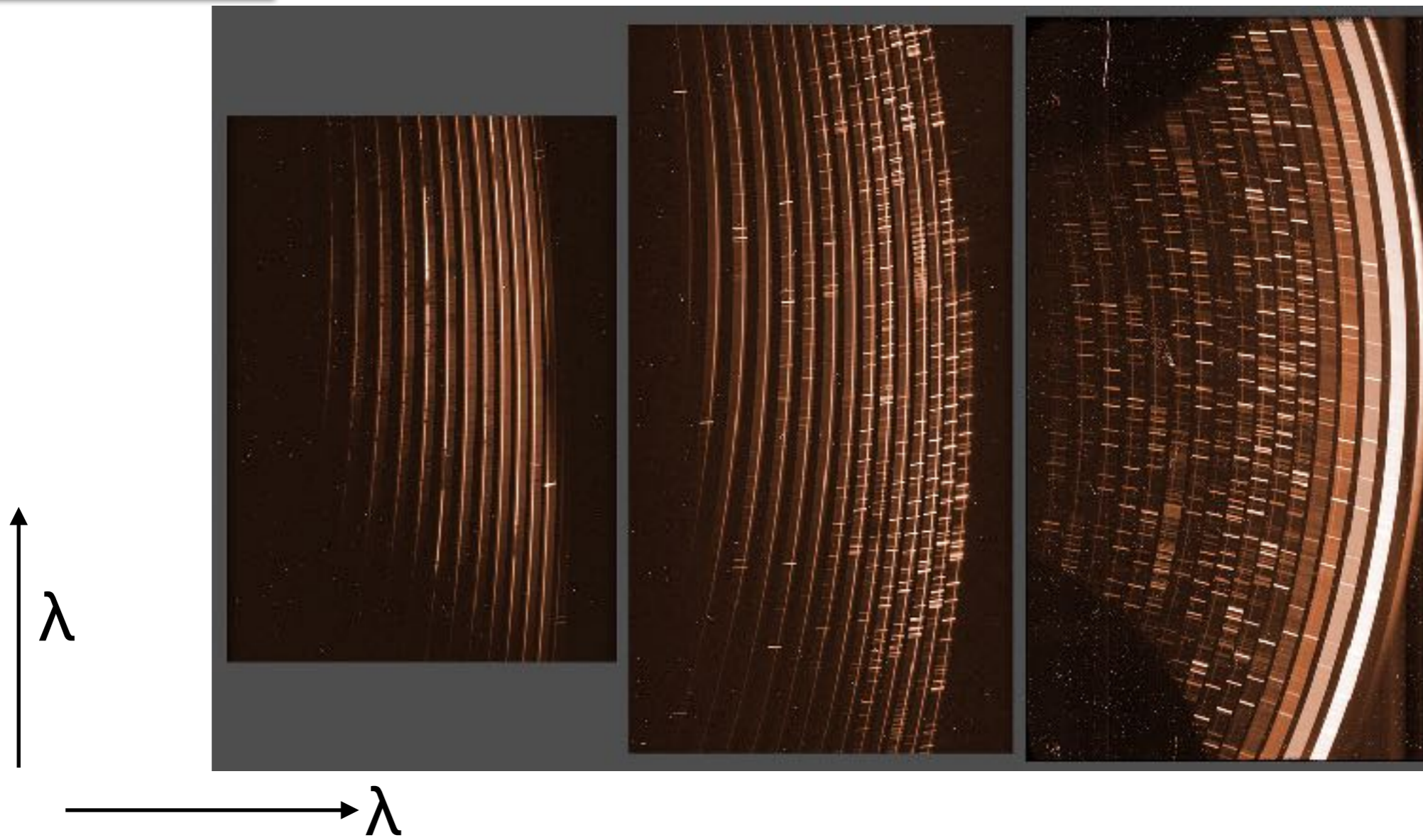

# Cosa impariamo dagli spettri?

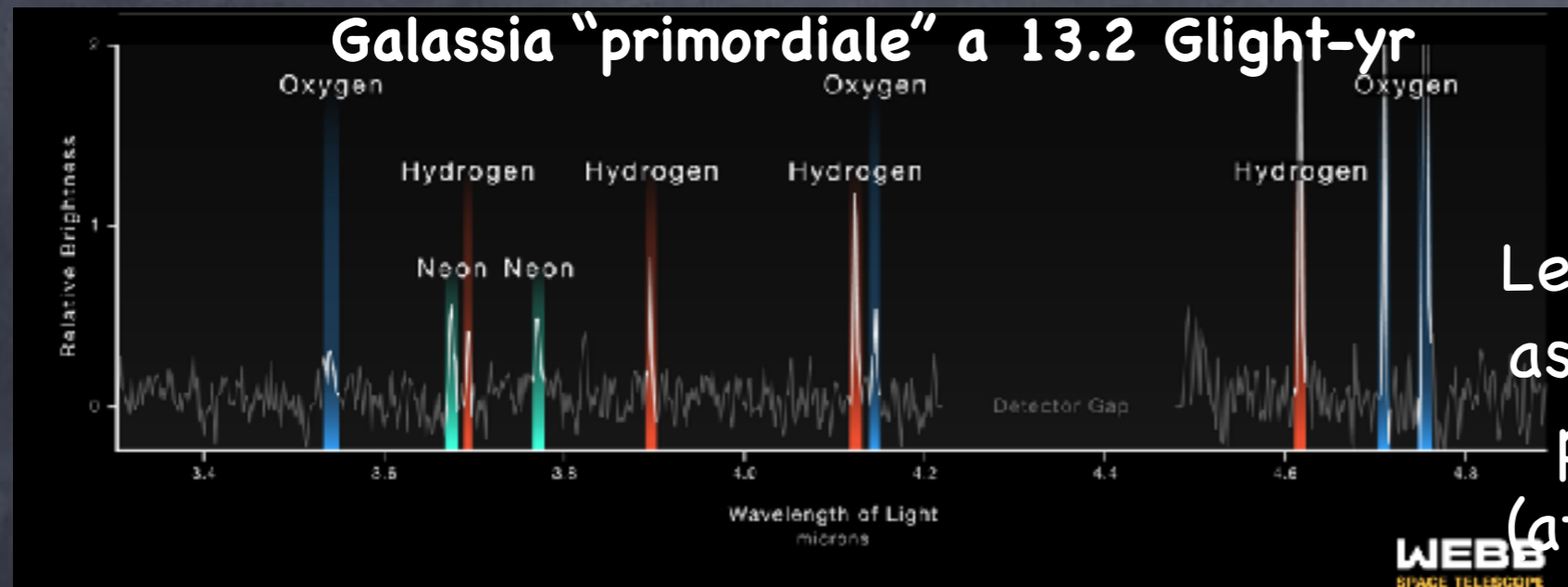

## 1) CHIMICA

Le righe/bande in emissione o assorbimento sono dovute alla presenza di elementi chimici (atomi o molecole) in vari stati di ionizzazione.

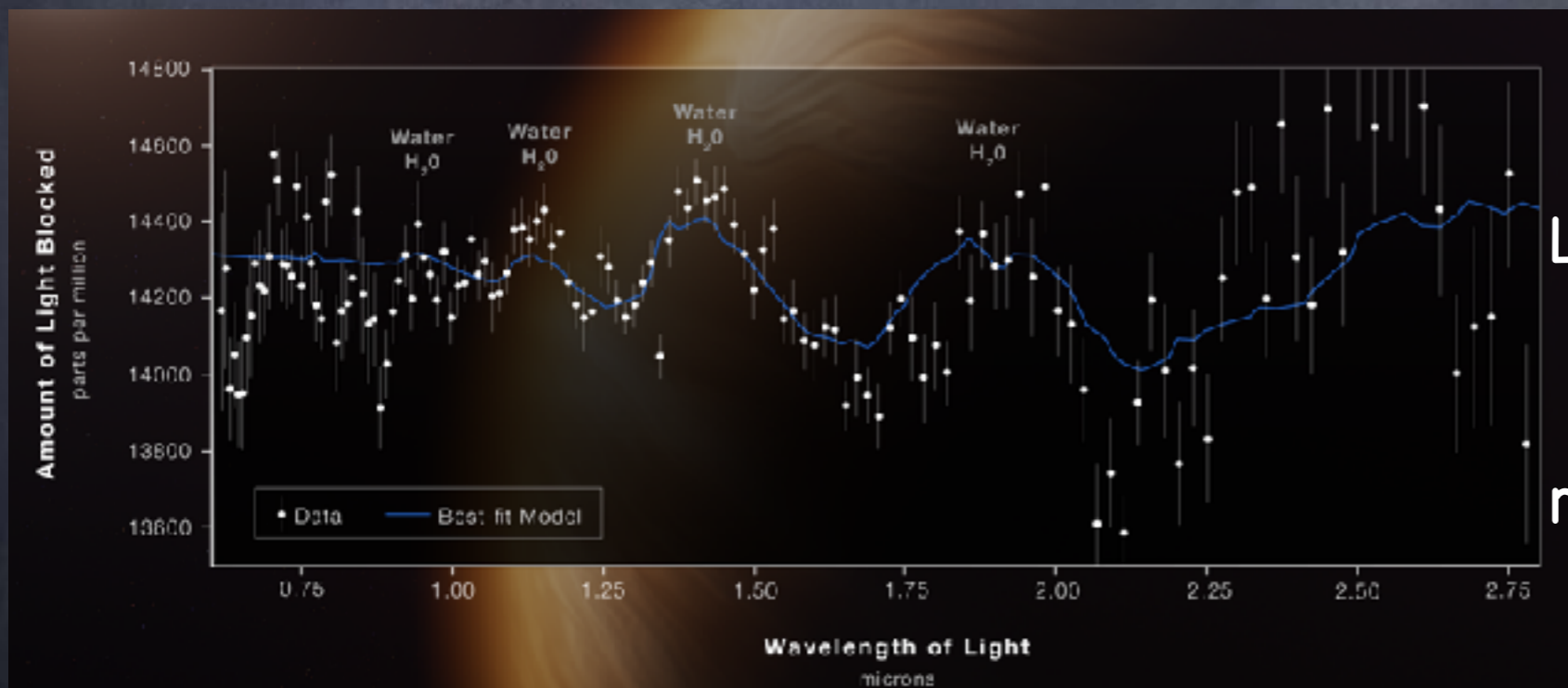

La loro analisi ci può dare la composizione chimica, densità, temperatura del mezzo che stiamo studiando.

Eso-pianeta intorno ad una stella nella Via Lattea

# Cosa impariamo dagli spettri?

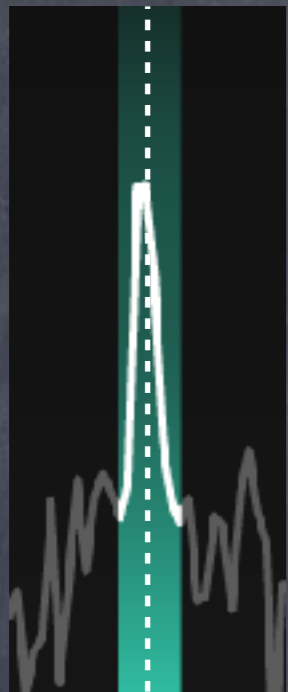

$\lambda_{oss}$

$$\frac{\lambda_{oss} - \lambda_{lab}}{\lambda_{lab}} = \frac{v}{c}$$

## 2) VELOCITA'

Il **centro** della riga misura la velocità rispetto alla Terra (effetto Doppler).

$\frac{v}{c} \ll 1$  "Moti propri"  
(e.g. stelle nella MW)

$z = \frac{v}{c} \gg 1$  "Redshift"  $z$  dovuto  
all'espansione  
cosmologica  
dell'Universo

$$\frac{\lambda_{oss} - \lambda_{lab}}{\lambda_{lab}} = \frac{v}{c} \rightarrow \lambda_{oss} = \lambda_{lab}(1 + z)$$

# Cosa impariamo dagli spettri?

$$\sigma \frac{\lambda_{oss} - \lambda_{lab}}{\lambda_{lab}} = \sigma \frac{v}{c}$$

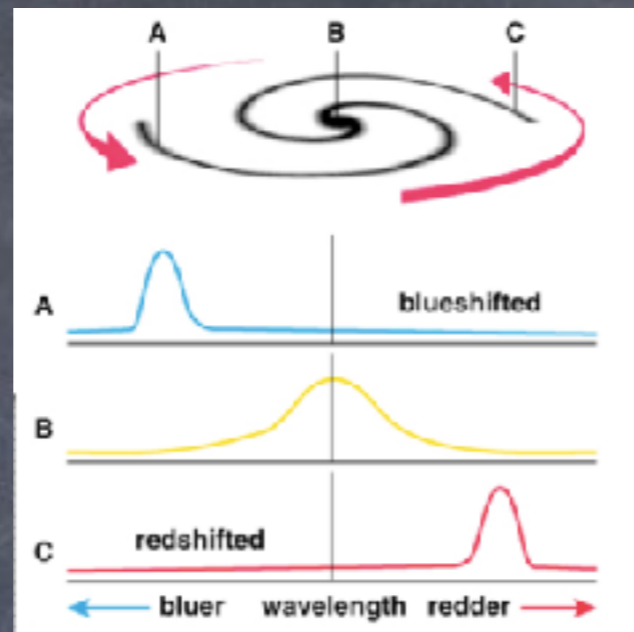

## 2) VELOCITA'

La **larghezza** della riga misura la dispersione di velocità all'interno dell'oggetto (effetto Doppler).

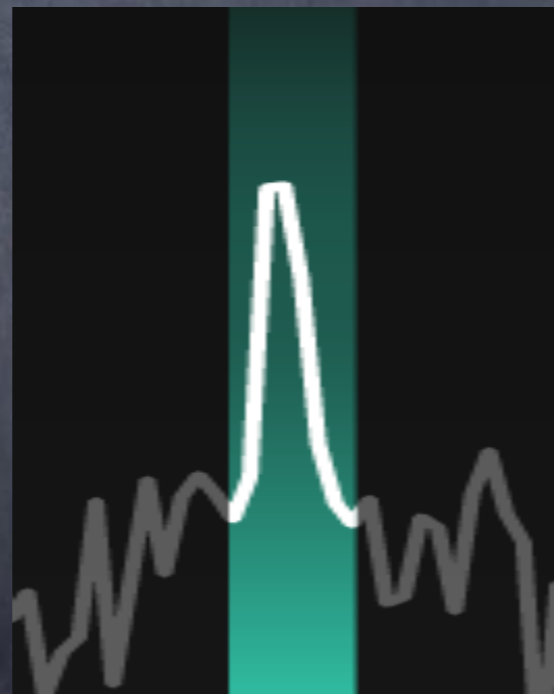
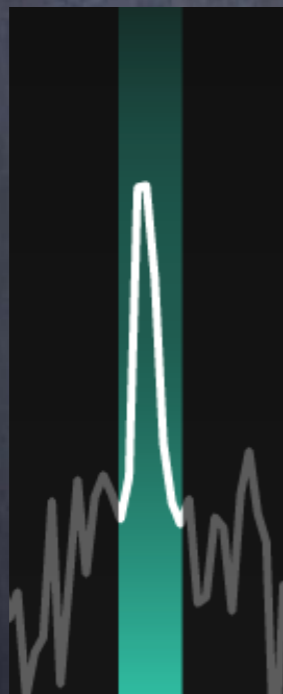

## Che risoluzione serve?

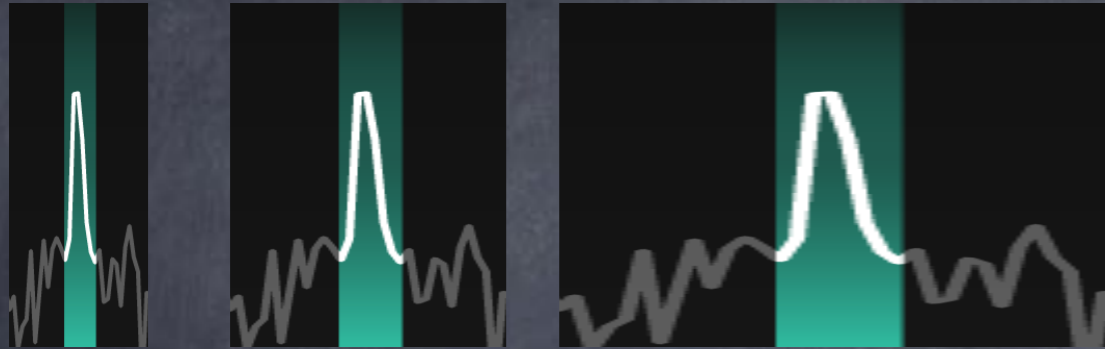

$$\frac{1}{R} = \frac{\lambda_{oss} - \lambda_{lab}}{\lambda_{lab}} = \frac{v}{c}$$

La **larghezza** della riga misura la dispersione di velocità all'interno dell'oggetto (effetto Doppler).

1) Moti dinamici in una galassia:

$$V_{rot}(Terra) \simeq 220 \text{ km s}^{-1} \rightarrow \frac{v}{c} \simeq \frac{1}{1000} \rightarrow R = 1000 - 10000$$

2) Moto di una stella perturbata dal suo pianeta:

$$V \simeq 1 \text{ m s}^{-1} \rightarrow \frac{v}{c} \simeq 10^{-8} \rightarrow R > 100.000 - 500.000$$

Come “sconfiggo” il seeing atmosferico?

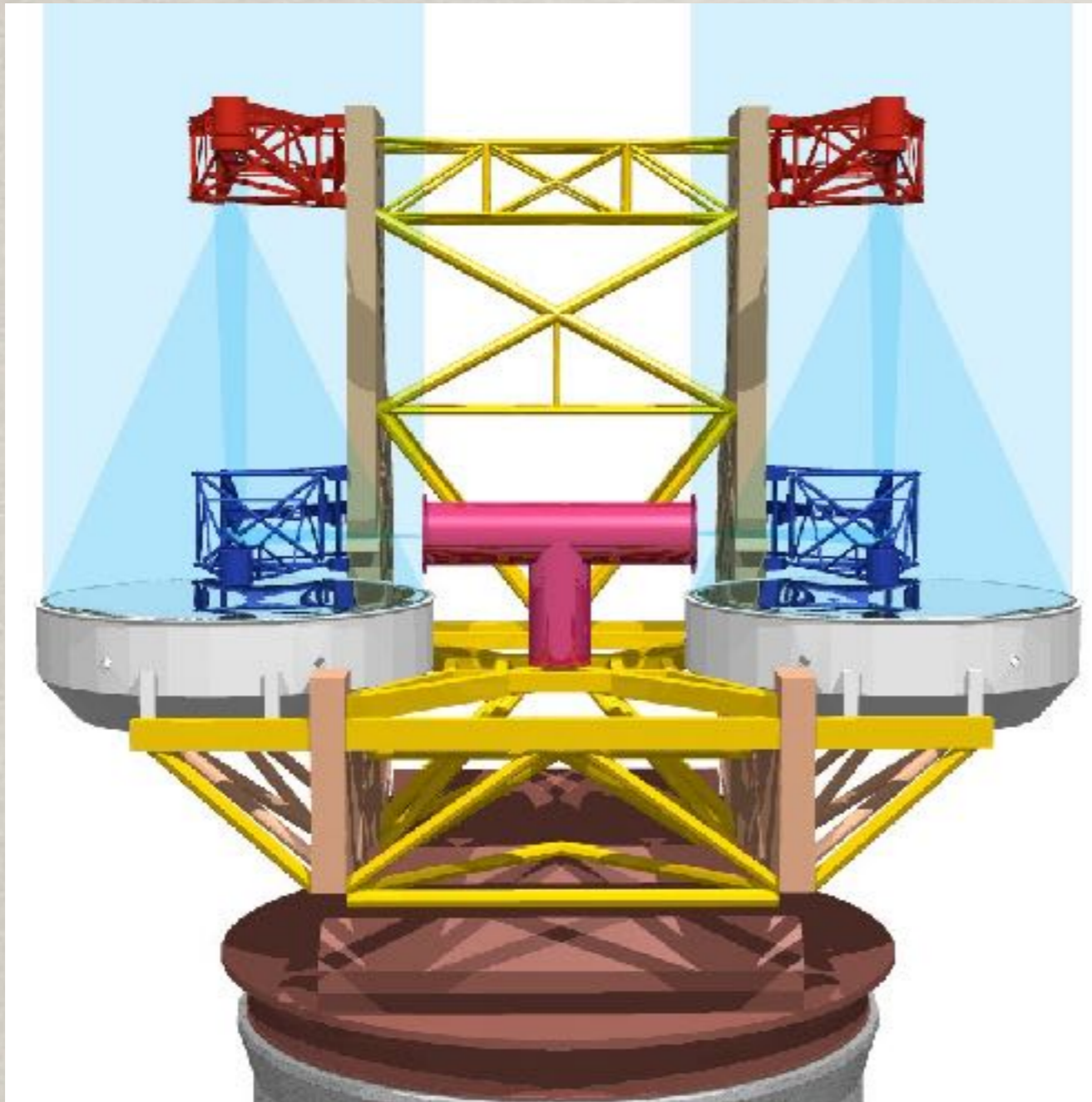

Large Binocular Telescope



# Come “sconfiggo” il seeing atmosferico?

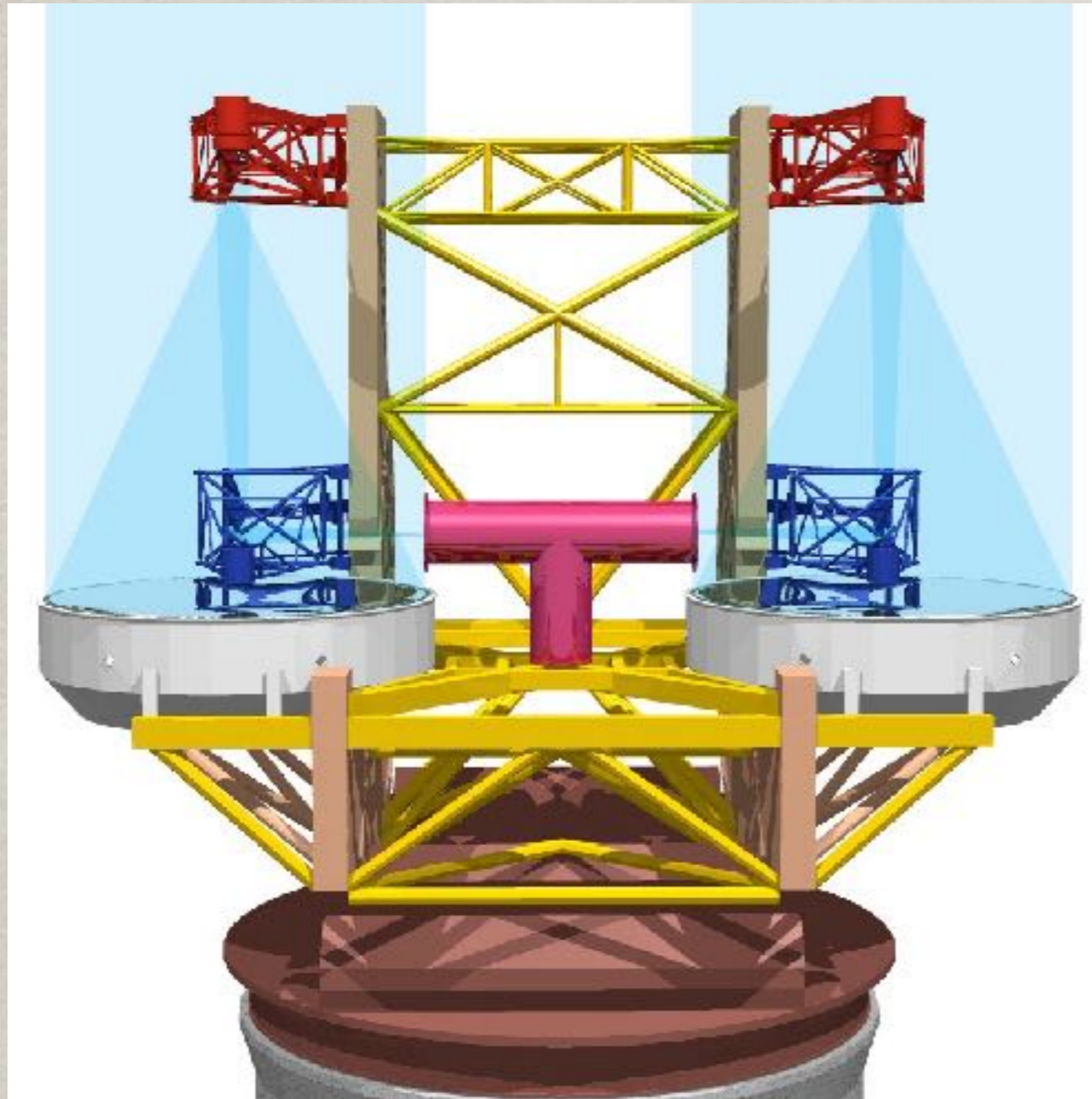

Secondary *deformable* mirrors at a much higher frequency (1kHz) to compensate for atmospheric turbulence:

**ADAPTIVE OPTICS**

(00's technology)

Large Binocular Telescope



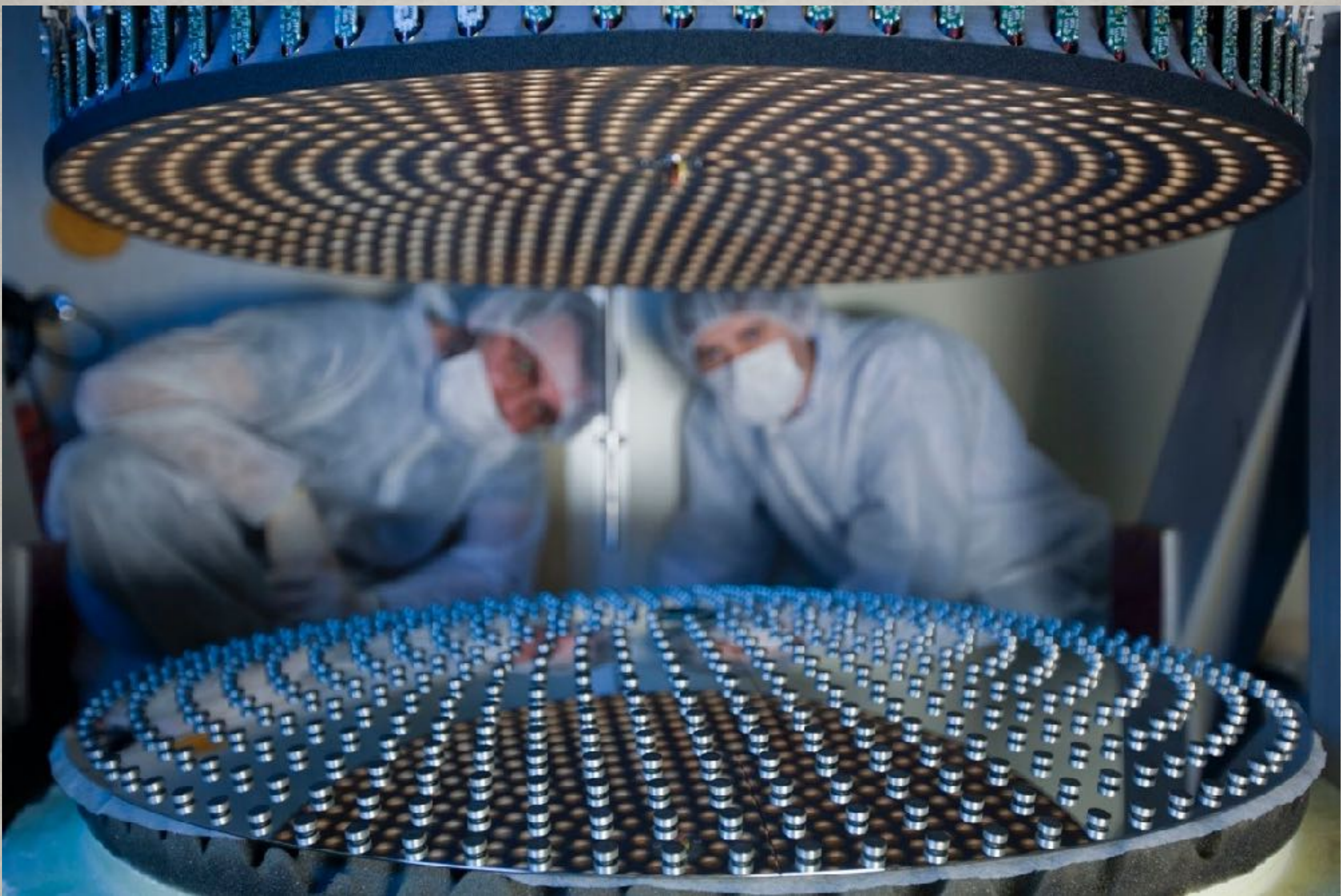

NATIONAL  
GEOGRAPHIC



NATIONAL  
GEOGRAPHIC



NATIONAL  
GEOGRAPHIC



NATIONAL  
GEOGRAPHIC



# The magic trick: Adaptive optics

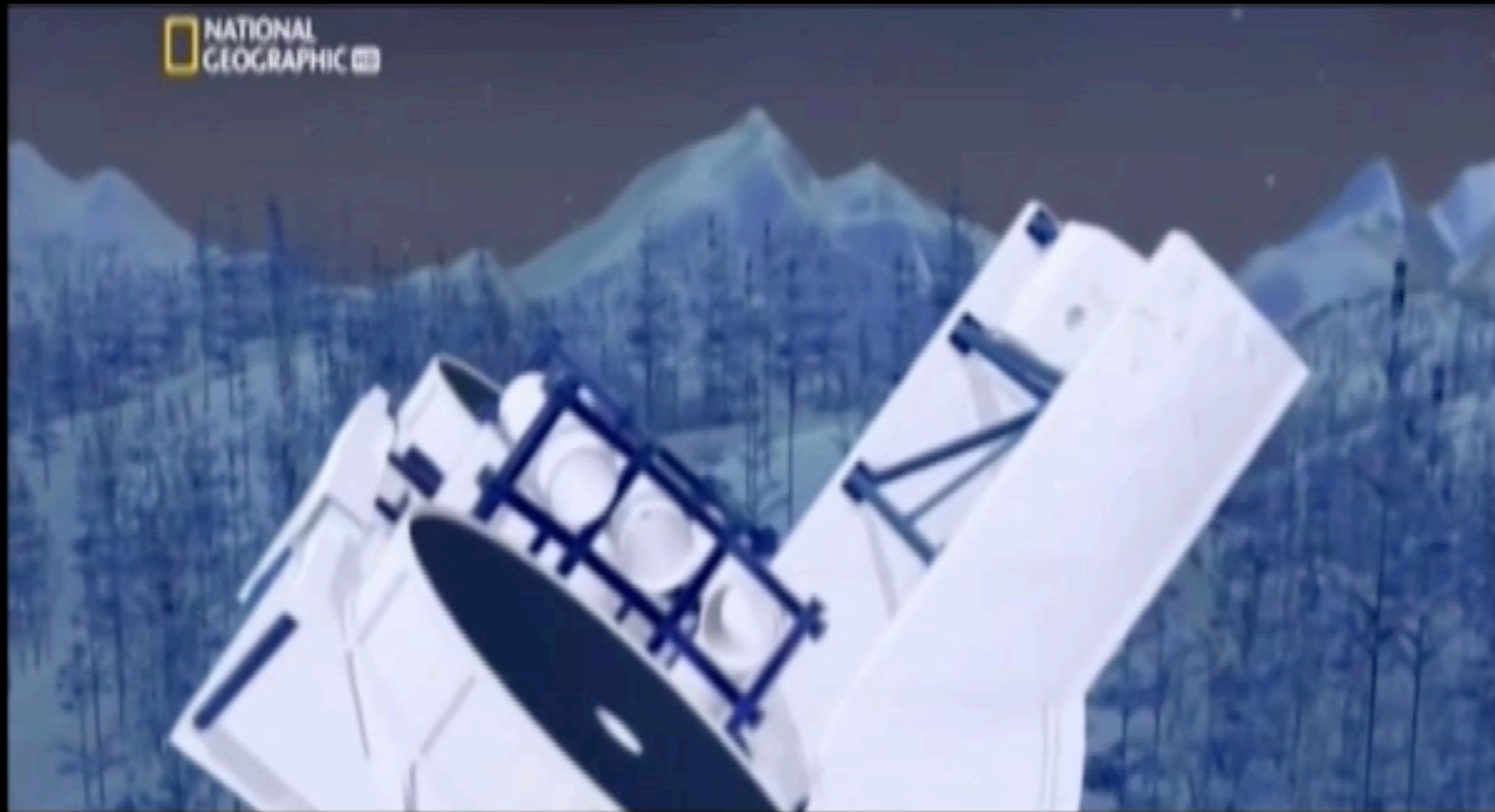



# The magic trick: Adaptive optics

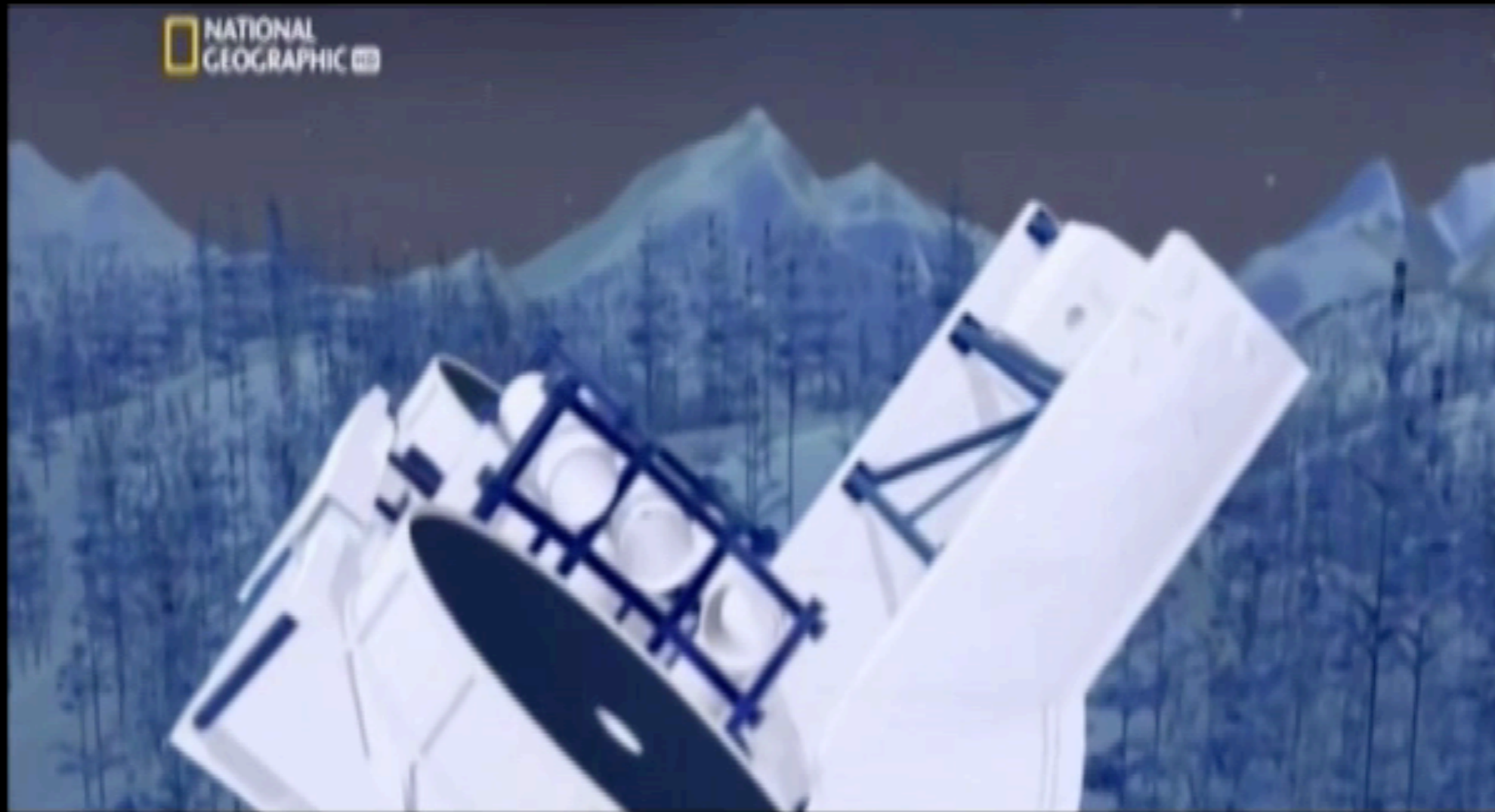

# FLAO test in Arcetri

## *AO corrected*

### AO closed loop:

Ref mag = 8.5  
Loop freq = 1kHz  
# modes = 400

### Injected turbulence:

FWHM = 0.8"  
L0 = 50m  
Vwind = 15 m/s

Estimated SR = 80%

## *Seeing limited*

### Simulated

### turbulence:

FWHM = 0.8"  
L0 = 50m  
Vwind = 15 m/s

H band

Scale 10mas/pix

## *Best PSF*

### AO closed loop:

High flux  
Loop freq = 1kHz  
# modes = 400

### Injected turbulence:

None

Estimated SR = 94%

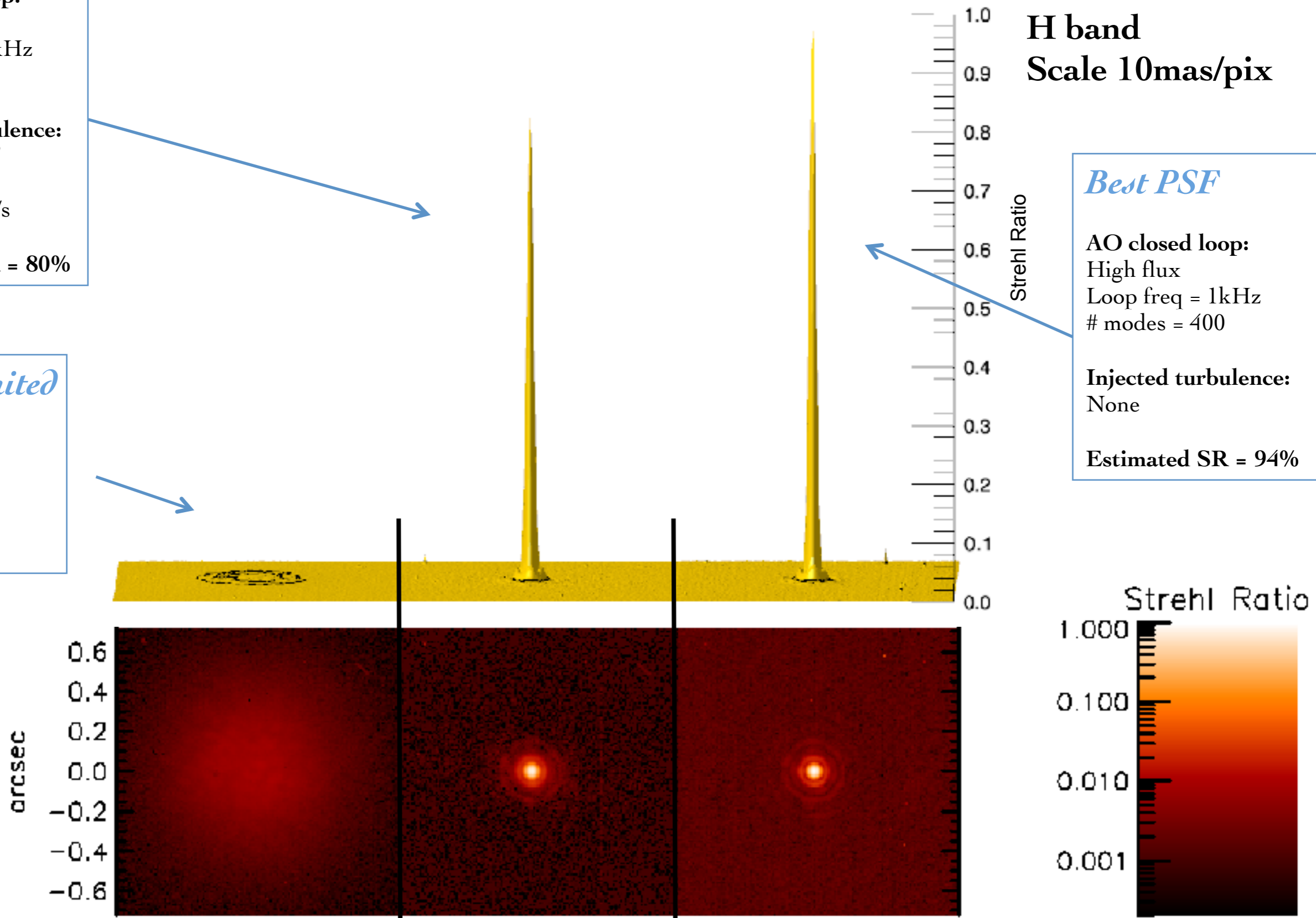

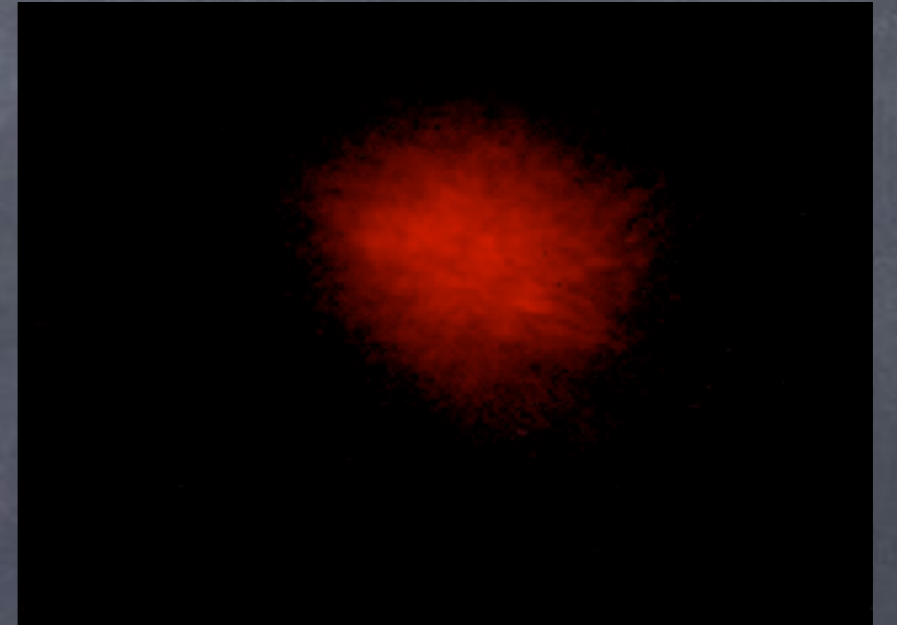
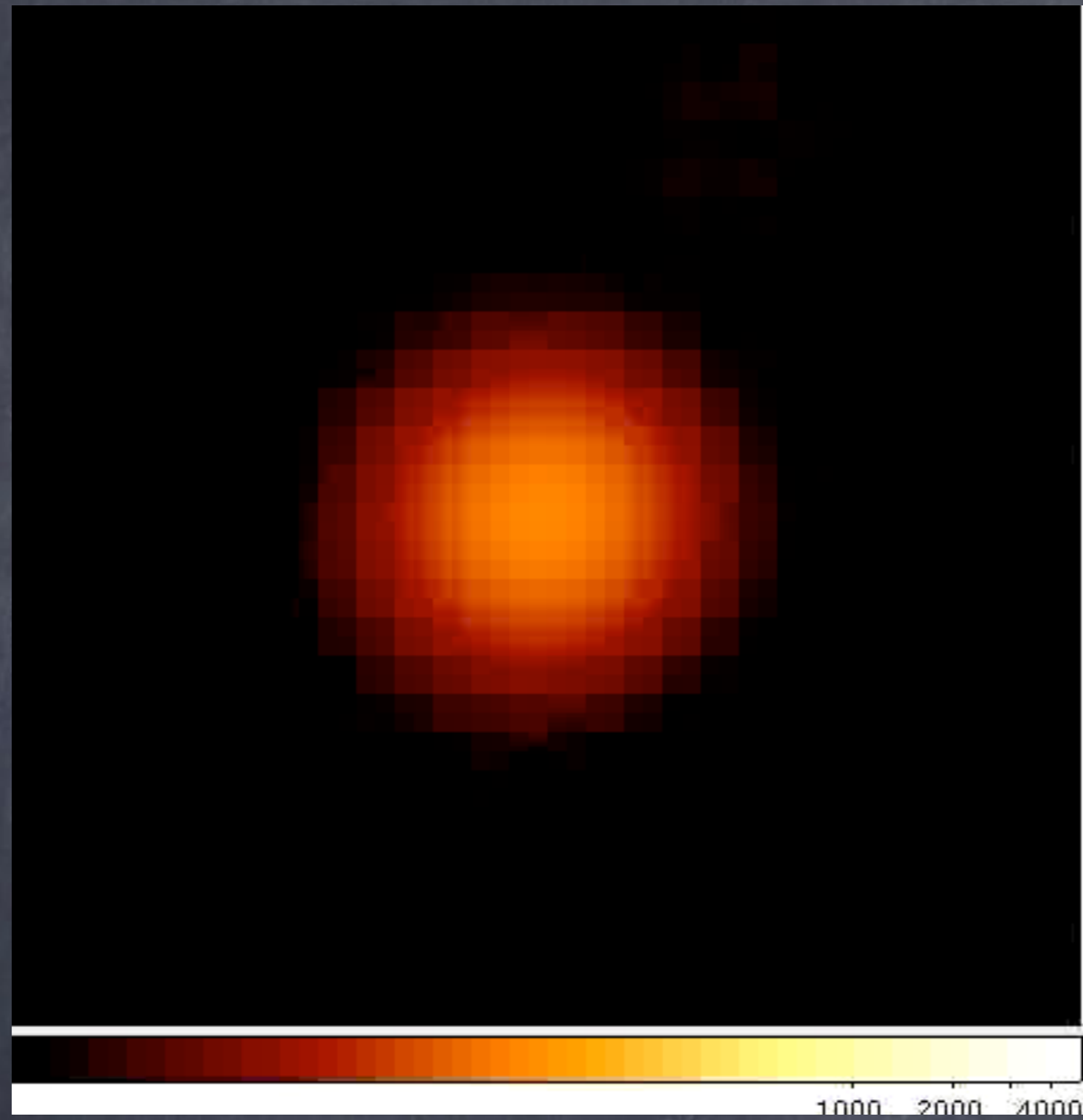

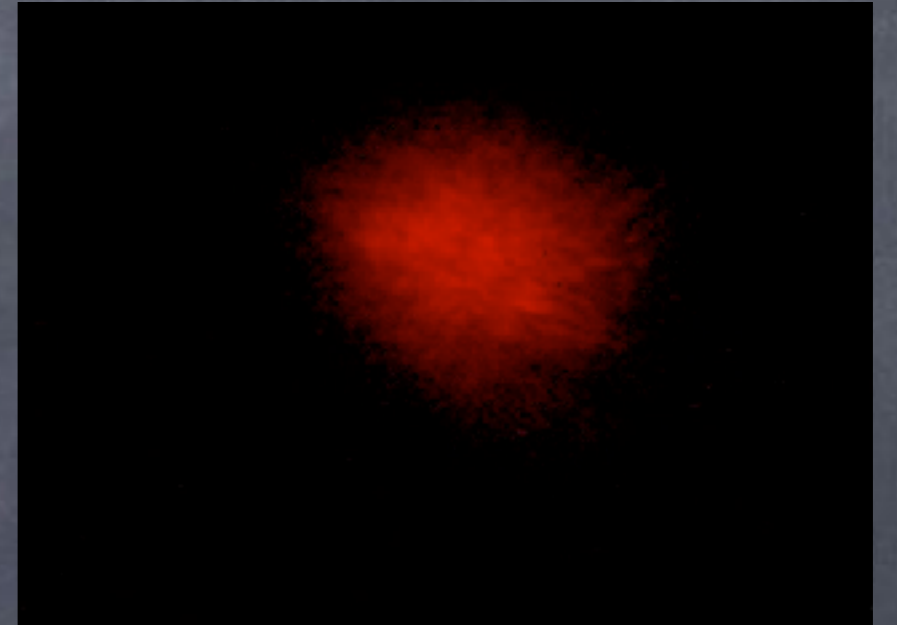
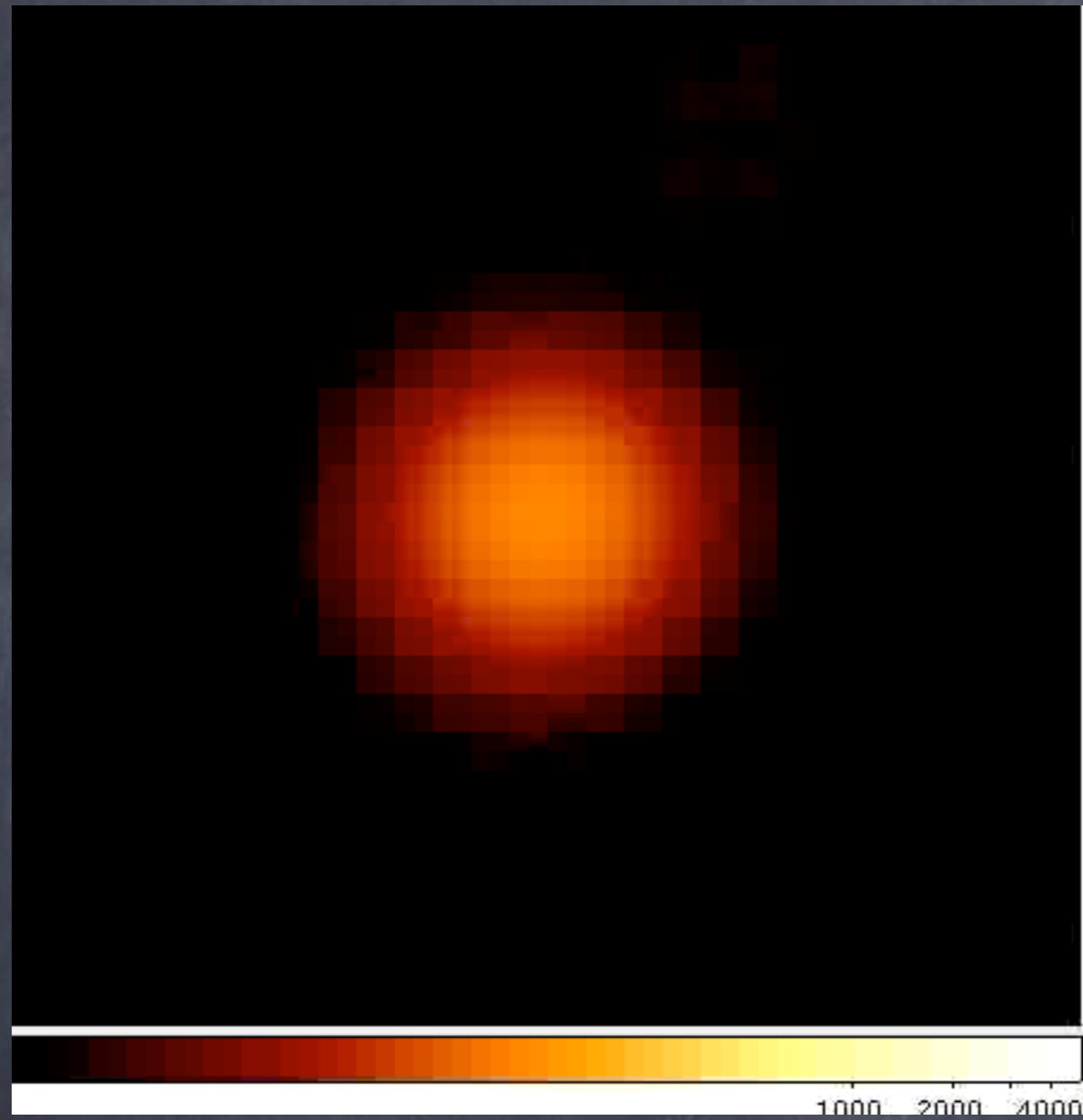

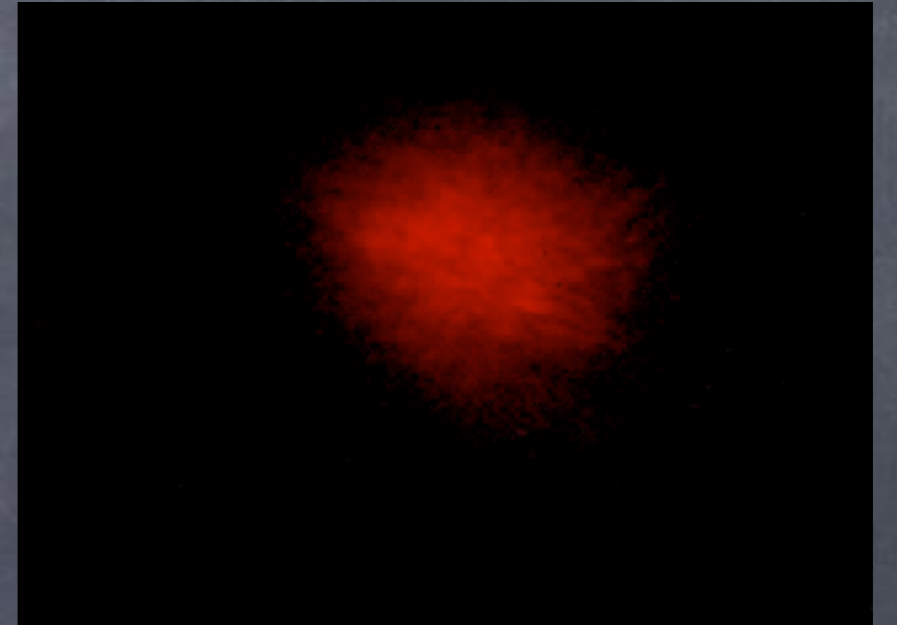
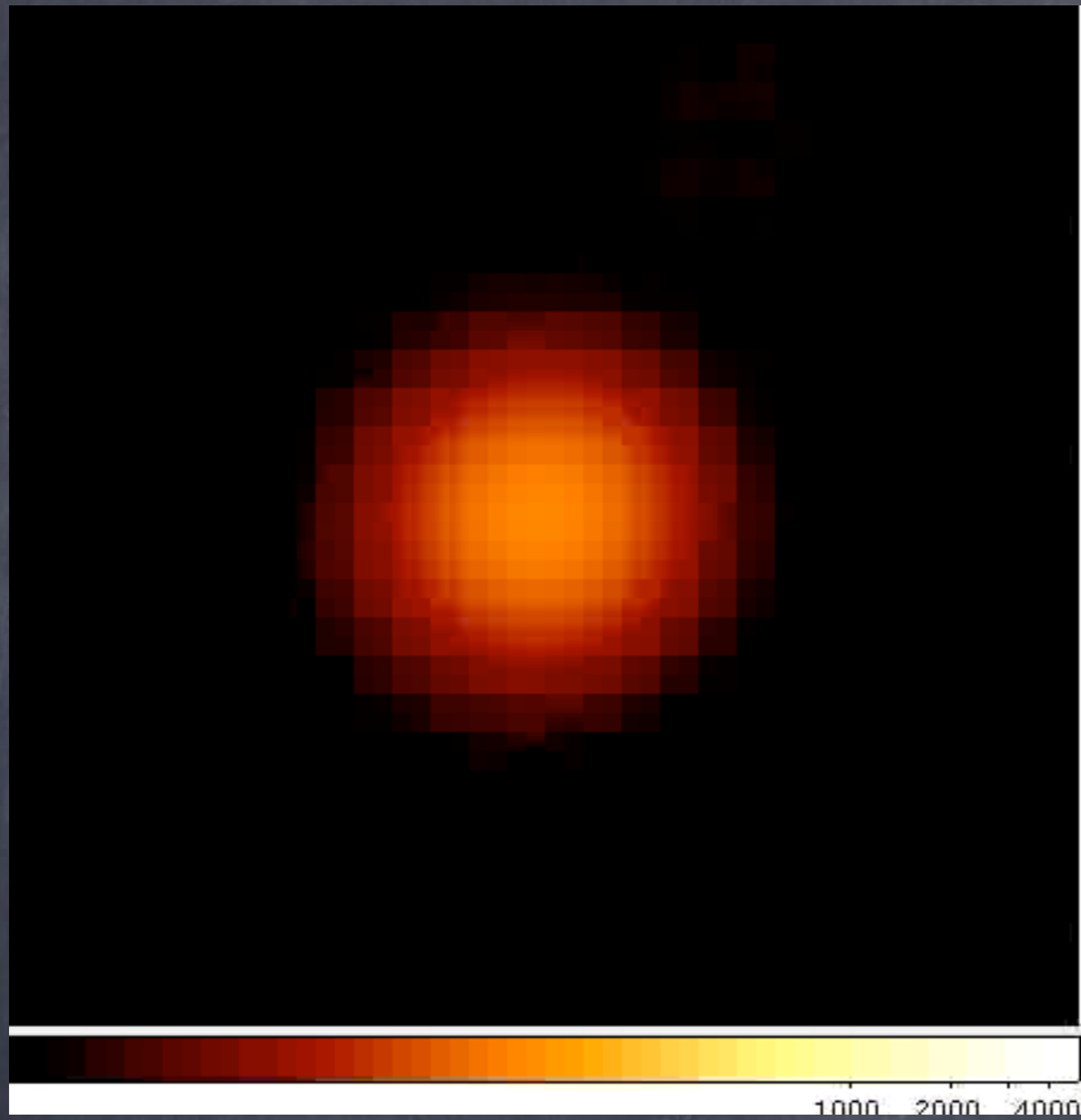

# Laboratory performances

Performances measured with FLAO in the Arcetri test tower.

SR measured on the IR Test Camera (INAF-OAB) in H band with 10mas/pix

Atmospheric disturbance of 0.8" @550nm wind speed 15 m/s

## Strehl Ratio in H band

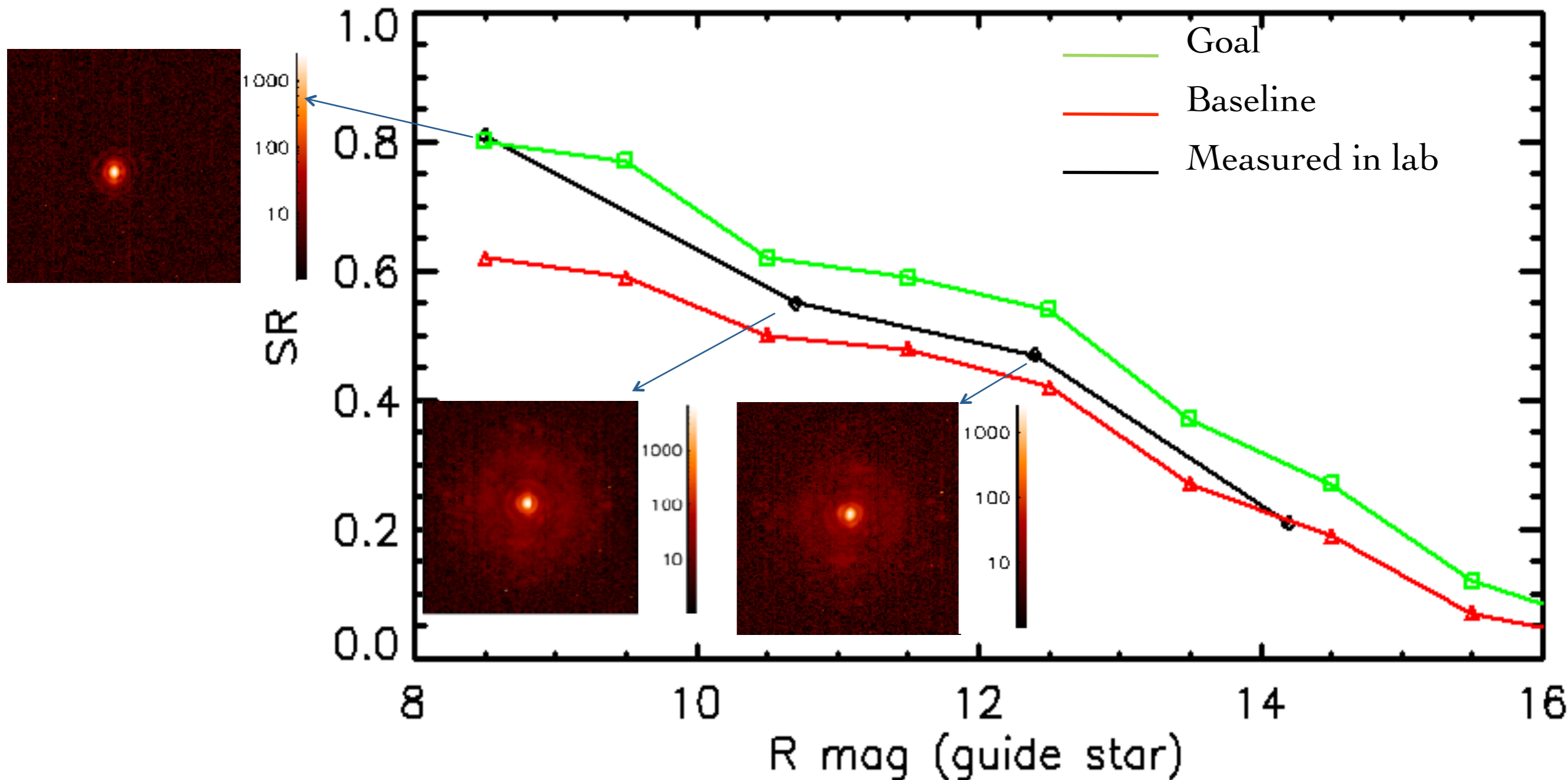

Natural Guide Stars cover 10-15% of the whole sky.  
For the rest, one needs to create artificial stars..  
Laser Guide Star

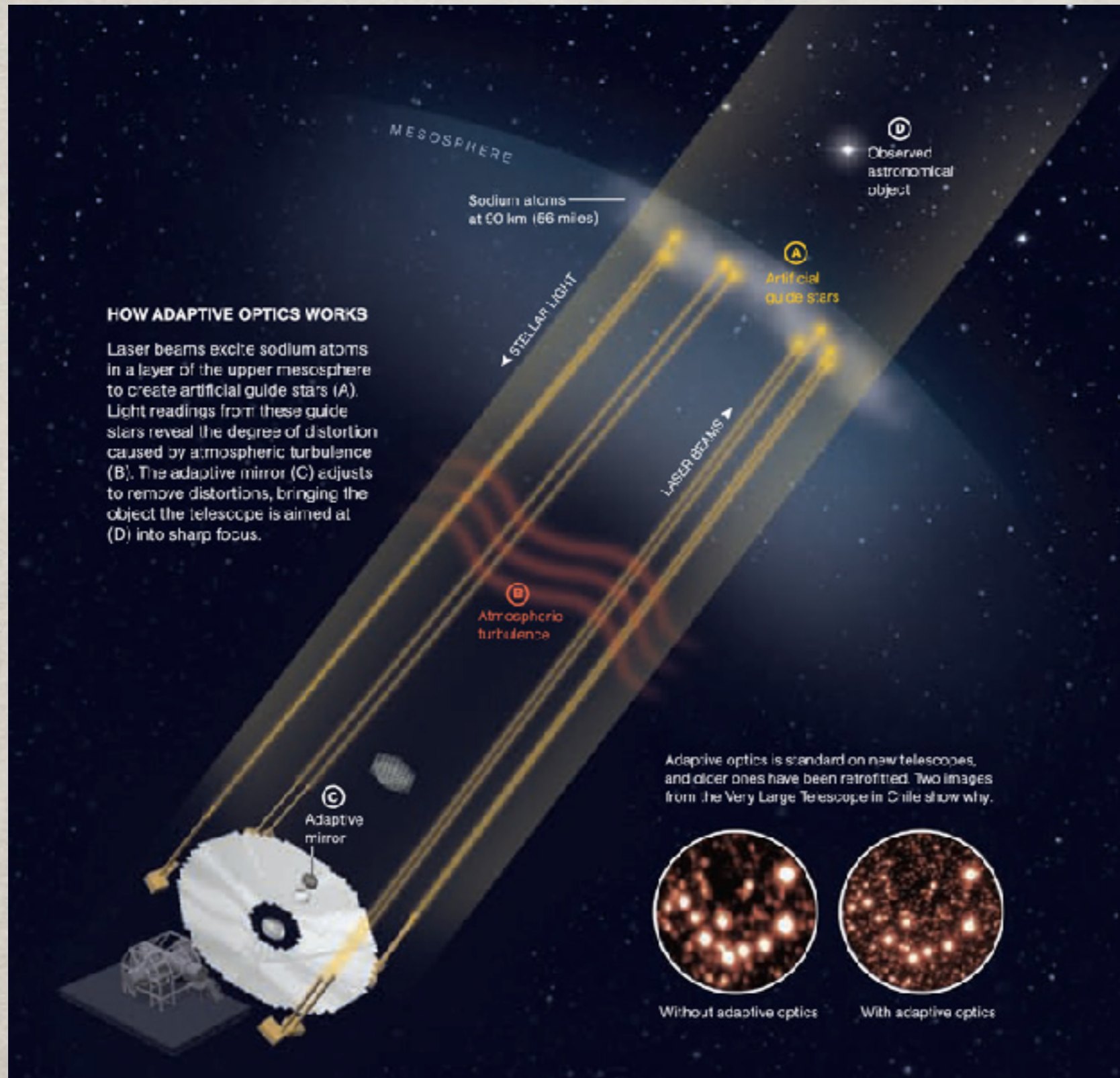

Na layer (90km altitude..)

Need high power Na lasers

# The Globular cluster M92

Data reduction G.  
Bono & F. Mannucci

10''

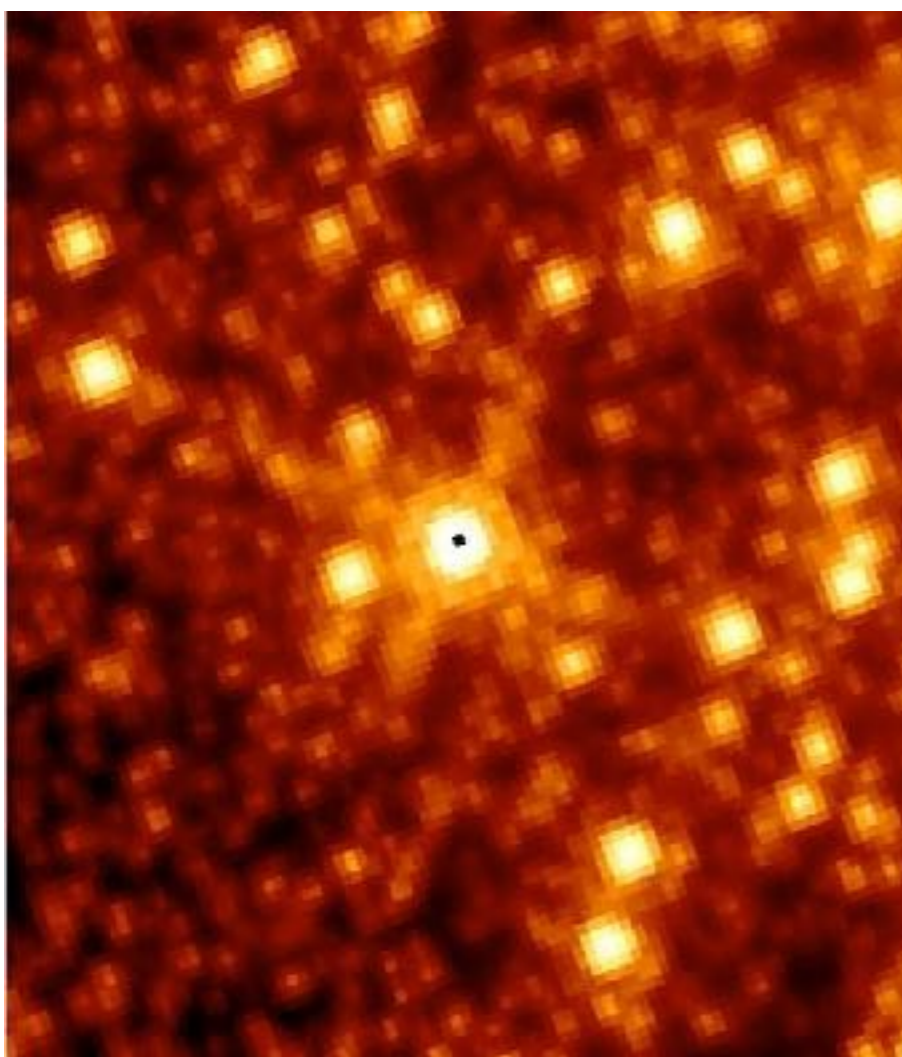

HST/WFPC3, H band 21min

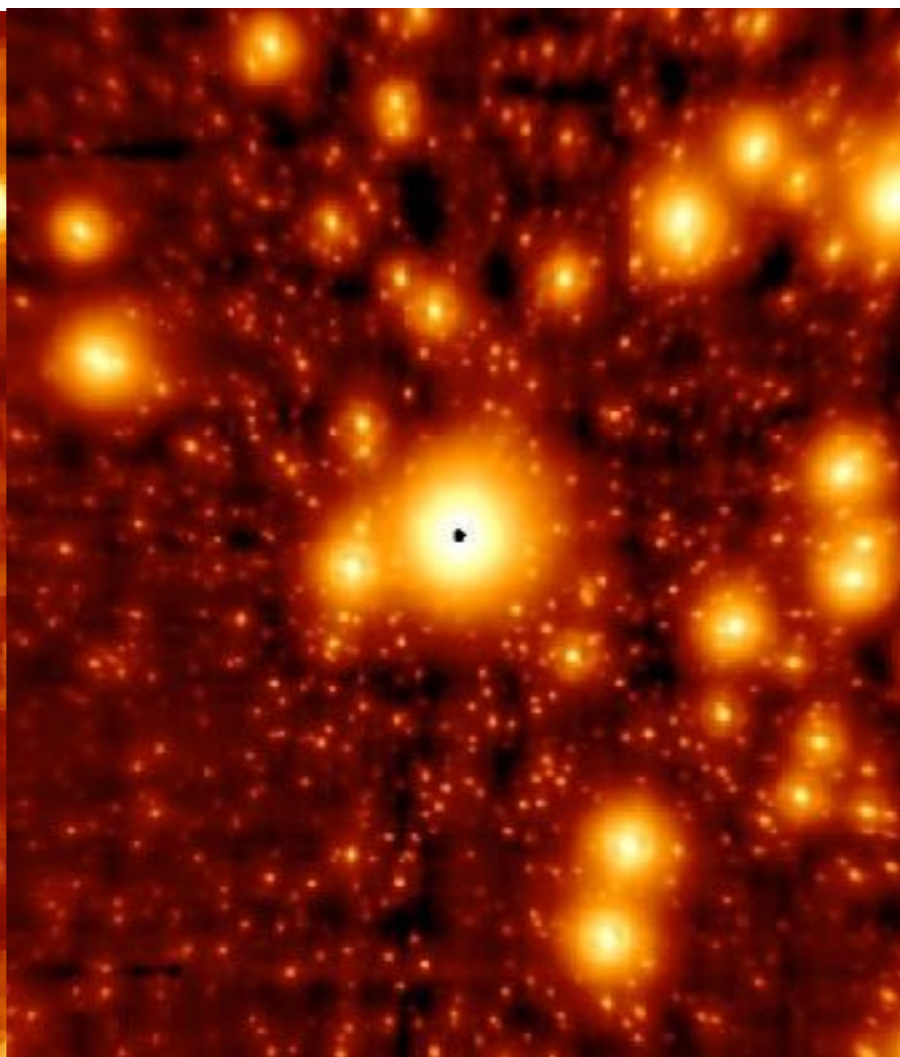

LBT J band, 6min

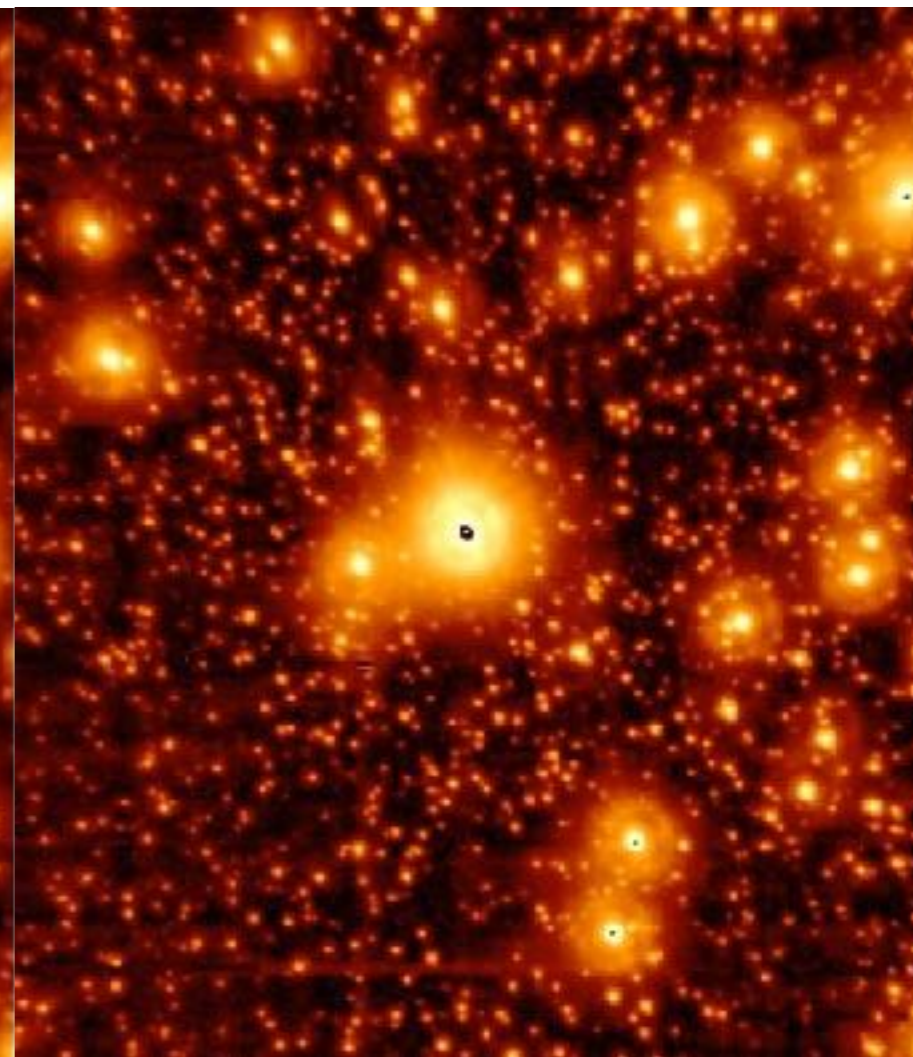

LBT K band, 3min

**Main data:** Rmag 12.0, 0.9'' seeing

**AO settings:** 0.5KHz, 15x15 subaps, 153 corrected modes



# Extremely Large Telescope

39m telescope

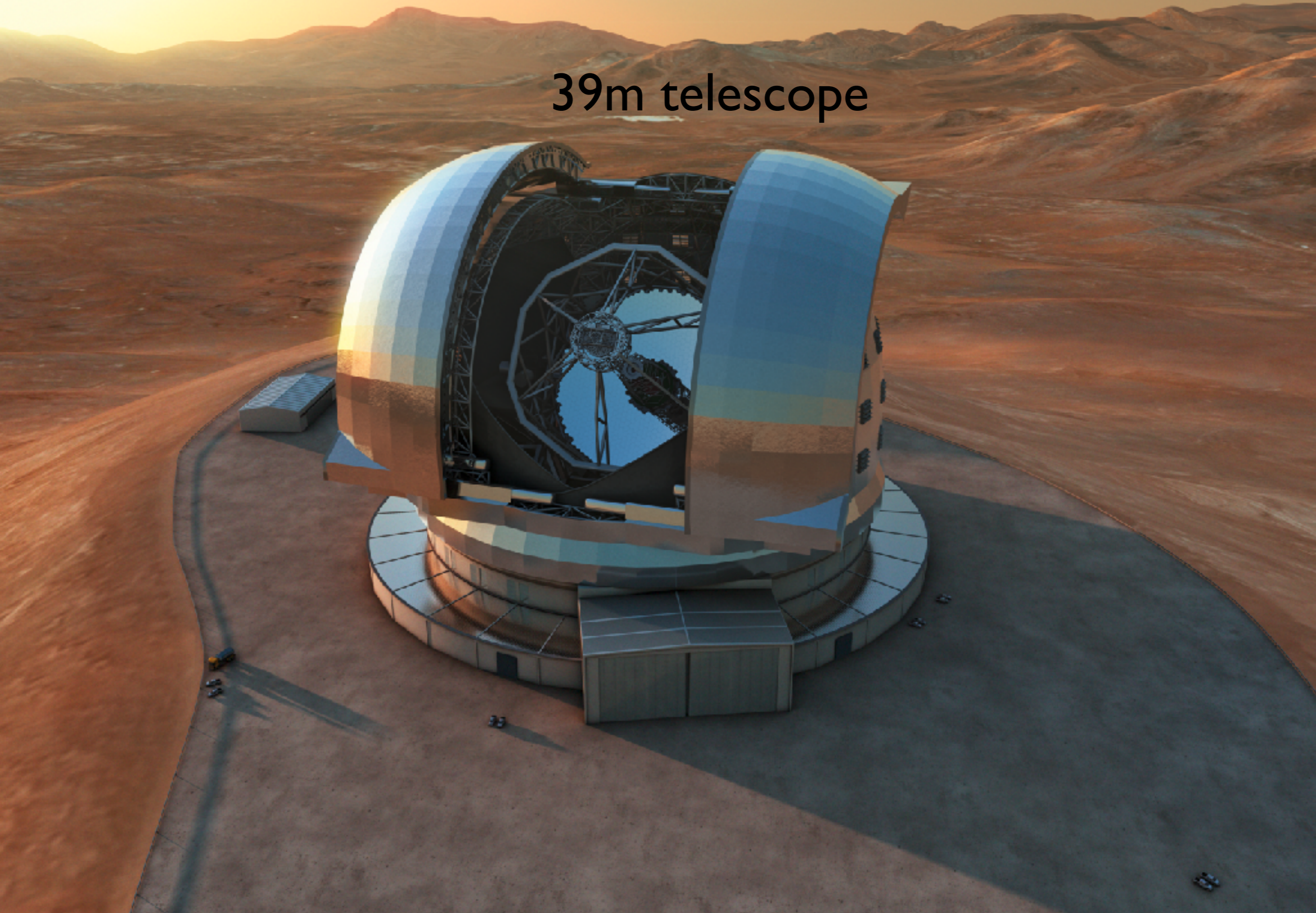

# ELT Optomechanics

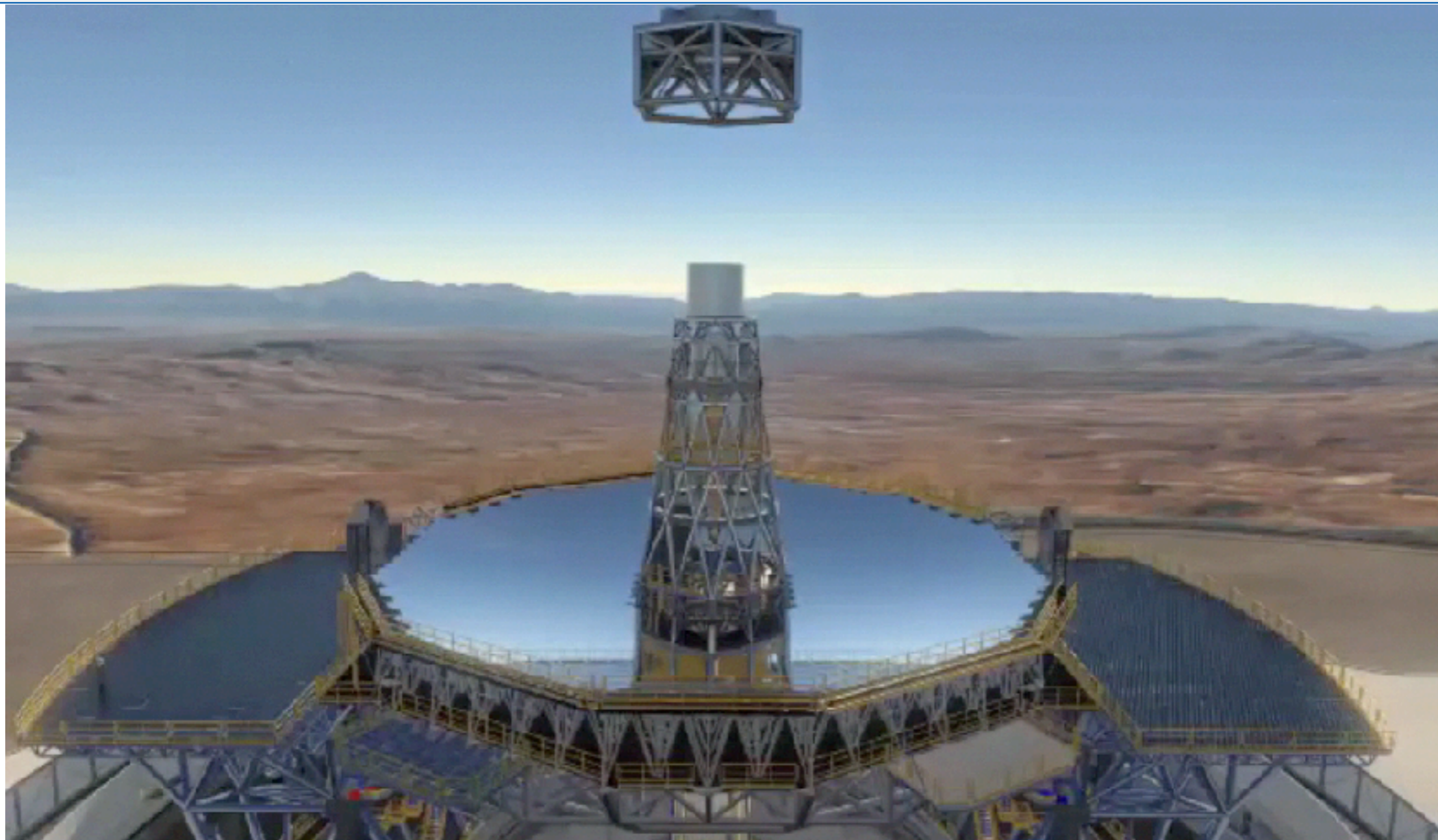

# ELT Optomechanics

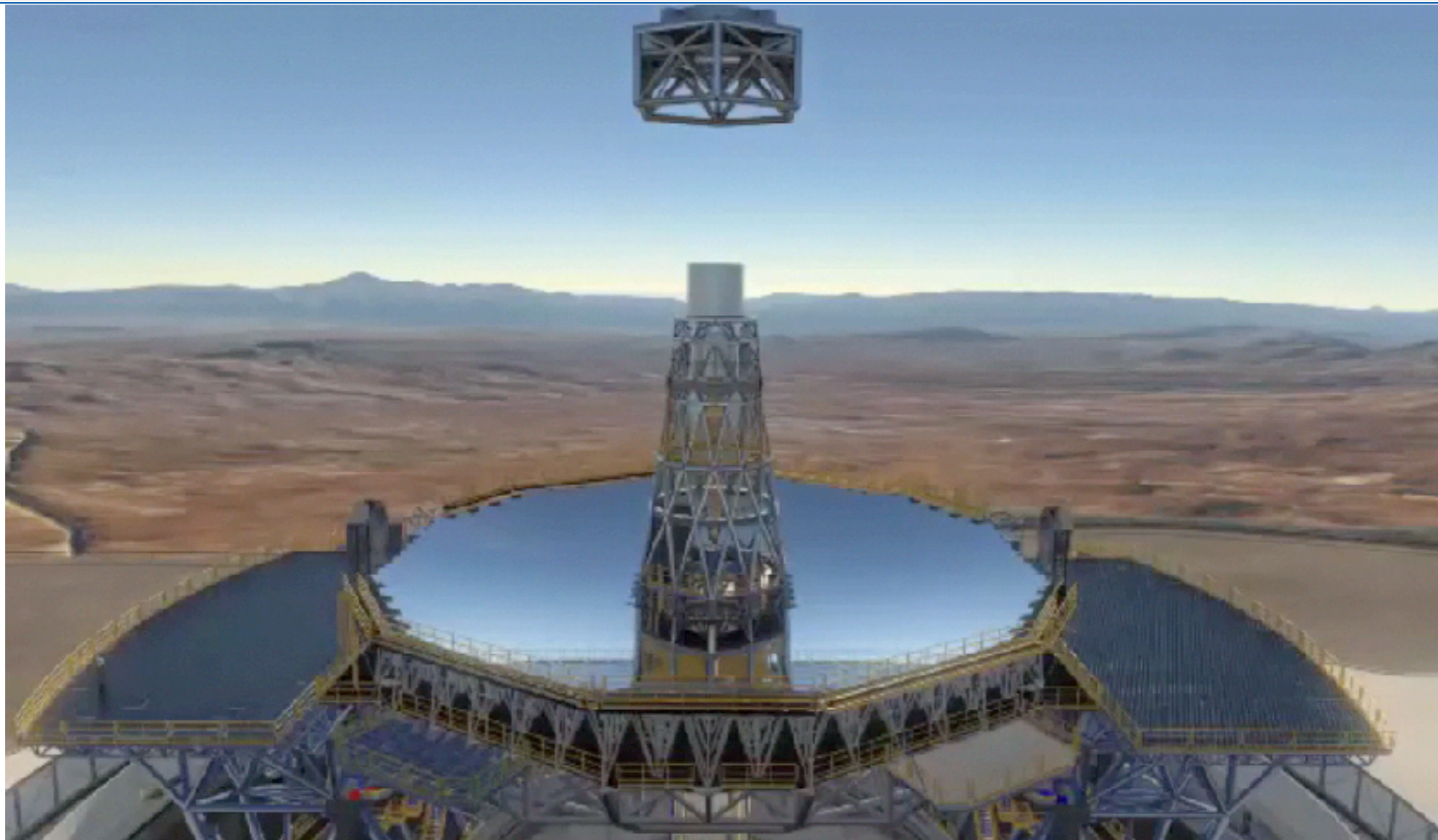

# ELT Optomechanics

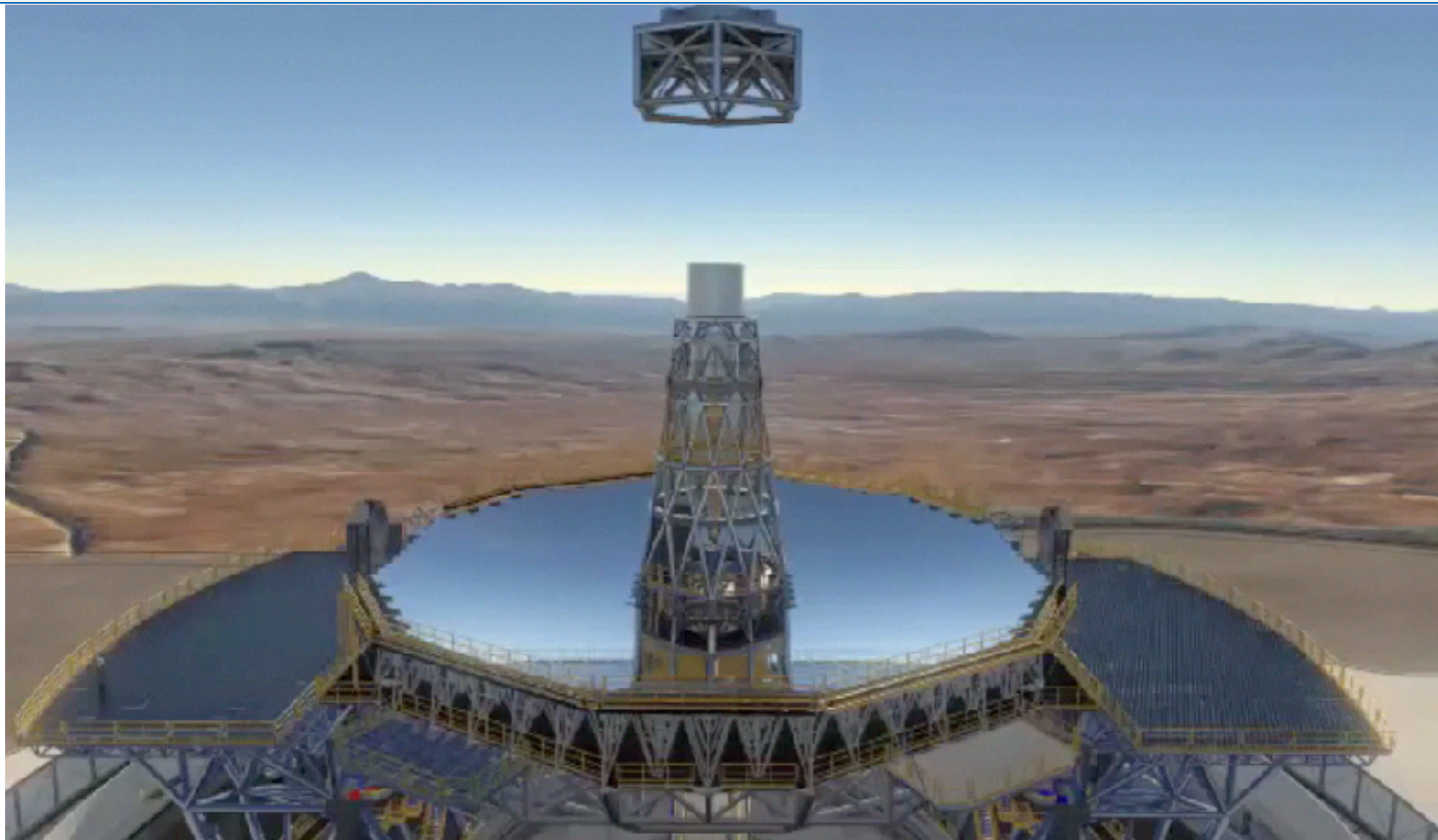



## ELT status

