

Ramo Shockley theory

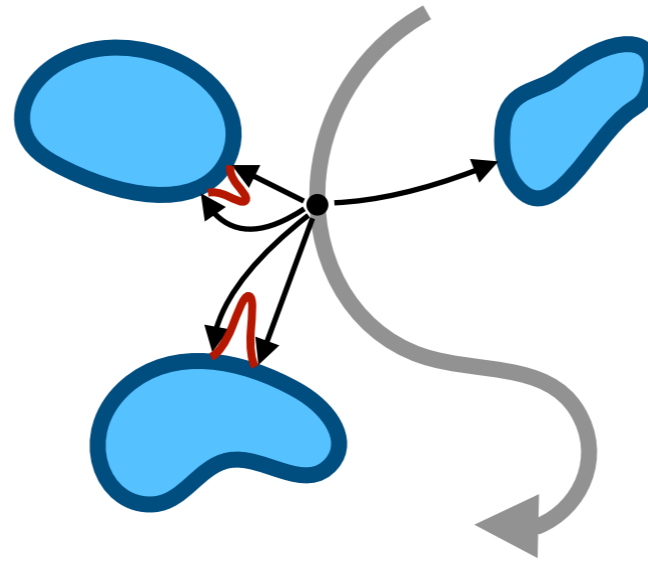

Philipp Windischhofer
University of Chicago

UK Advanced Instrumentation Training; May 14, 2024



THE UNIVERSITY OF
CHICAGO

How to compute the electrical signal induced in your detector

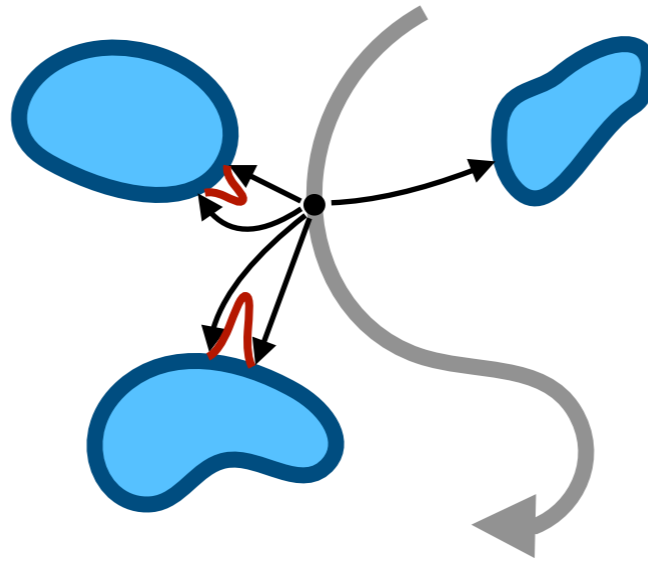

Philipp Windischhofer
University of Chicago

UK Advanced Instrumentation Training; May 14, 2024



THE UNIVERSITY OF
CHICAGO

From moving charges to electrical signals

Many types of **particle detectors** generate **electrical signals** when **exposed to moving charged particles**

Silicon detector
(*ATLAS tracker*)

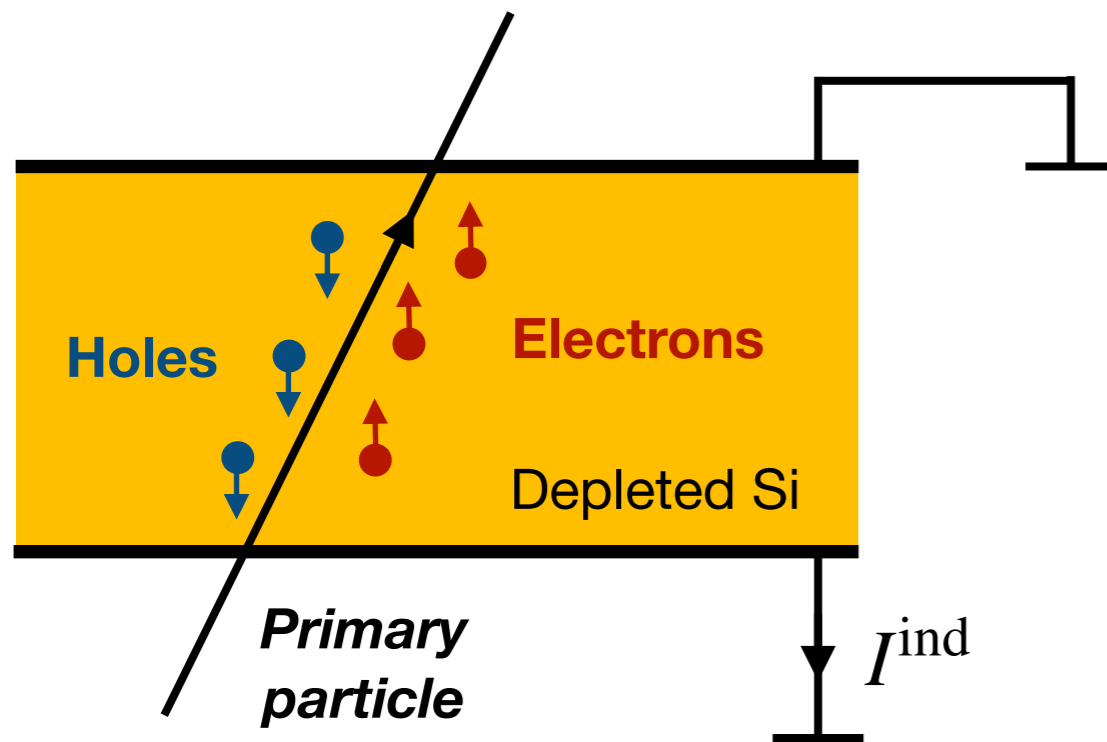

Beam current transformer
(*LHC instrumentation*)

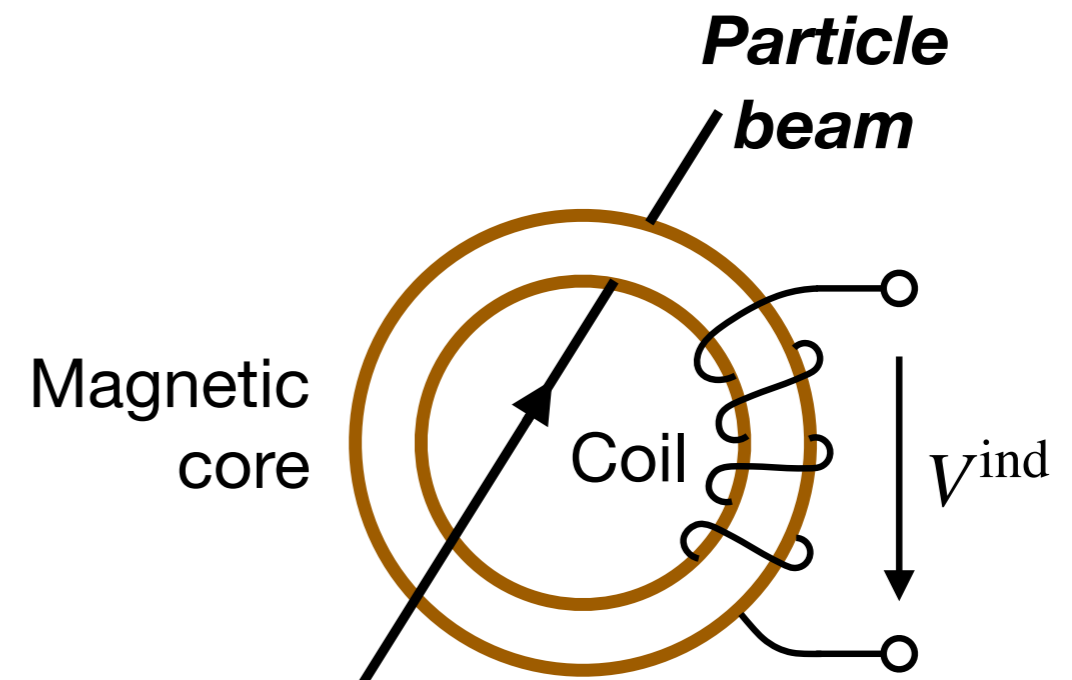

From moving charges to electrical signals

Many types of **particle detectors** generate **electrical signals** when **exposed to moving charged particles**

Radio astronomy
(e.g. ALMA)

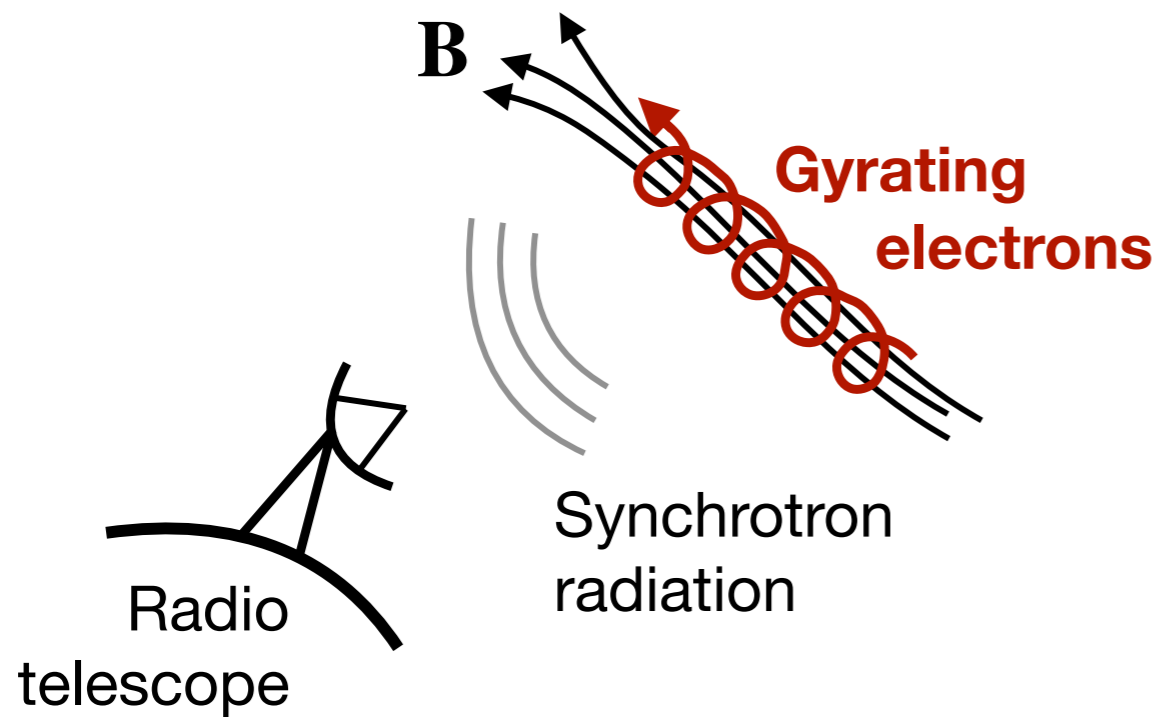

Neutrino observatories
(e.g. RNO-g)

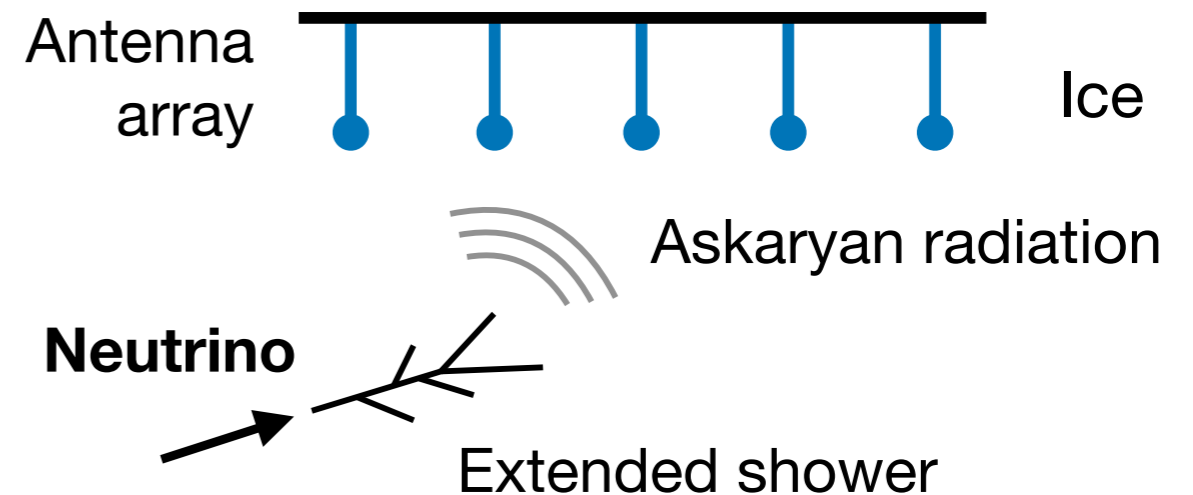

Goals for today

The physics / intuition behind signal formation

Electrostatics, surface charges, induction, ...

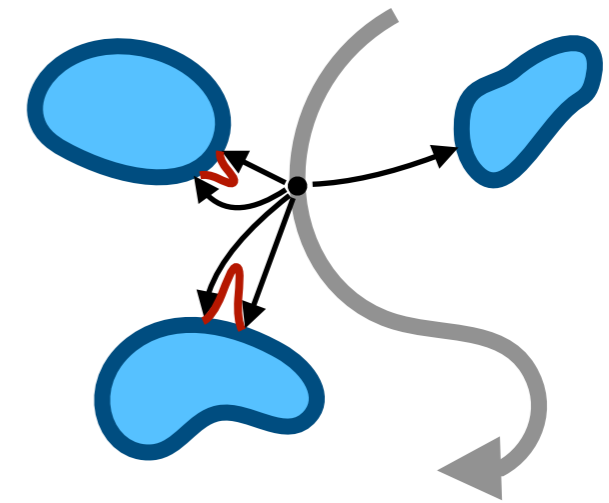
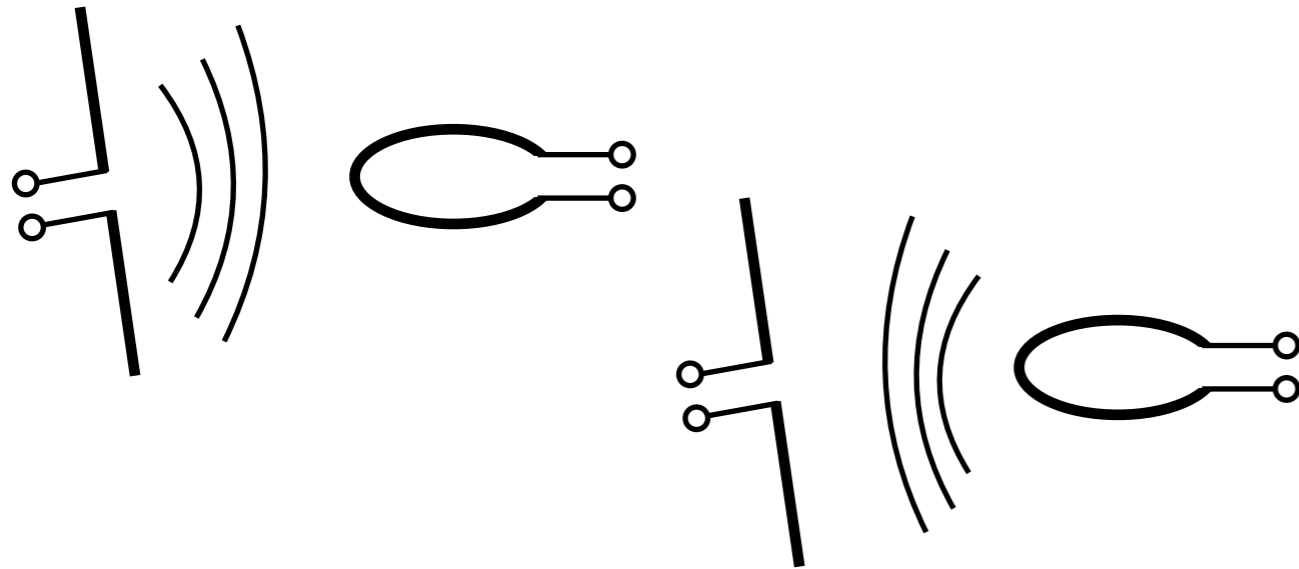

A general and efficient method

*Without approximations—
they just muddle the water*

Signals in silicon detectors

Pixels, LGADs, ...

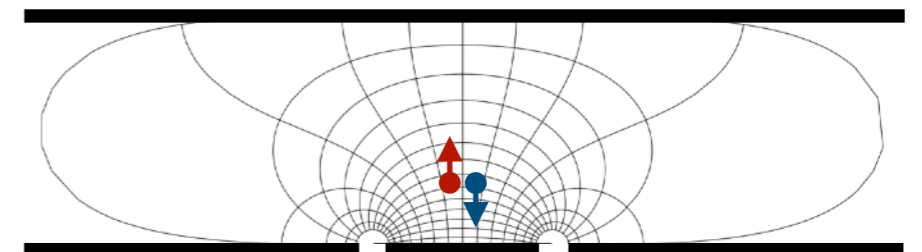

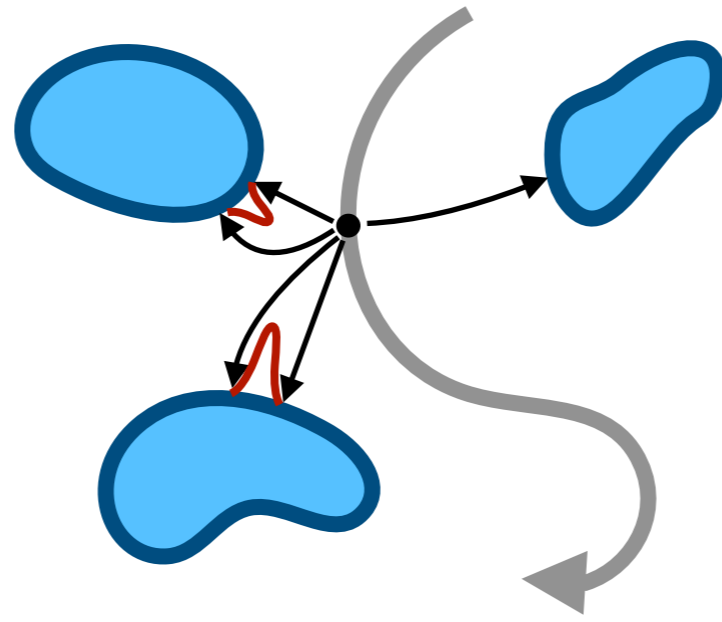

The physics of signal formation

Moving charges and conducting electrodes

For today:

Detector = arrangement of **metallic electrodes** (*and other materials*) through which a **charged particle moves** along a **known trajectory**

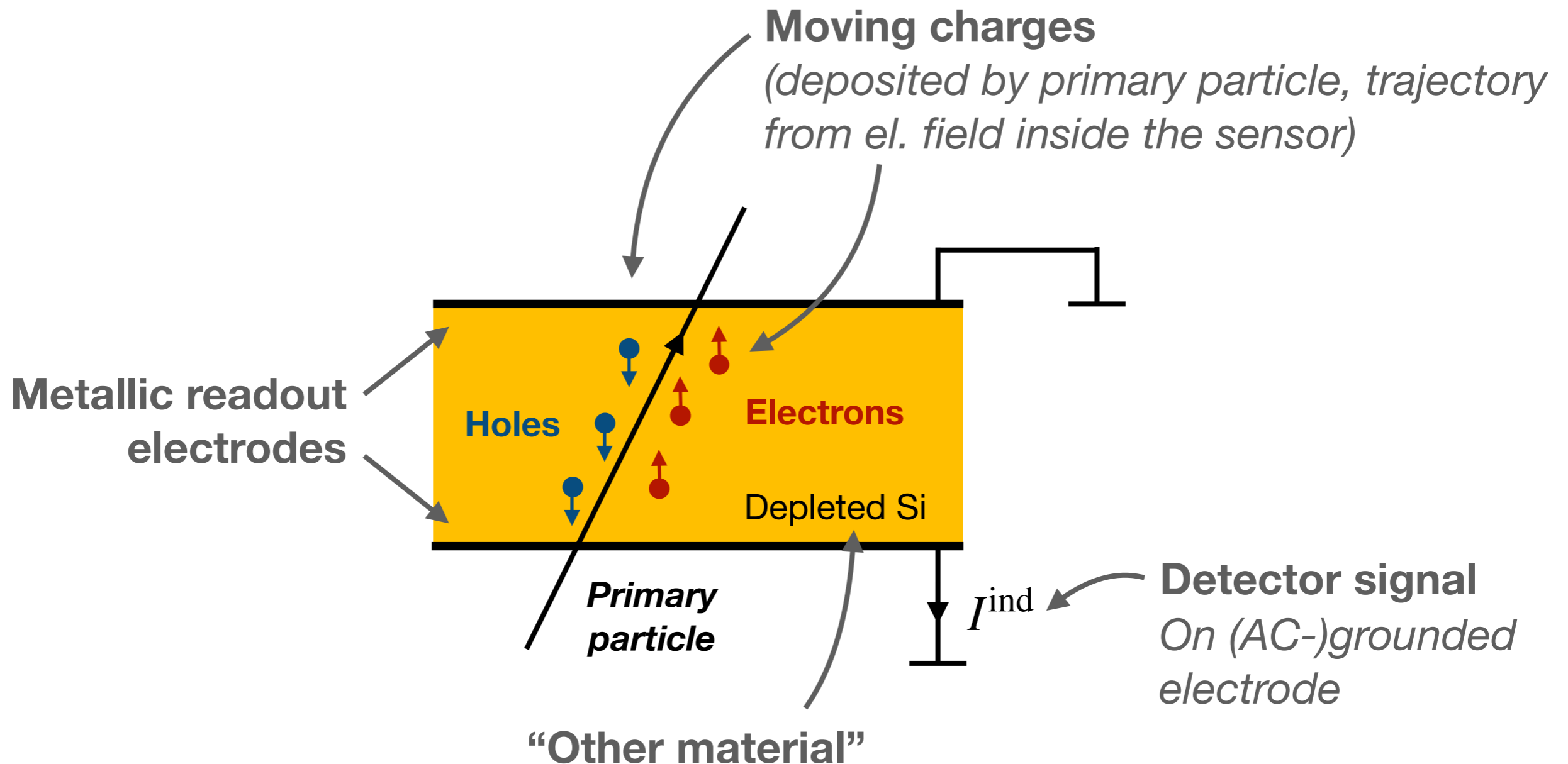

Moving charges and conducting electrodes

For today:

Detector = arrangement of **metallic electrodes** (*and other materials*) through which a **charged particle moves** along a **known trajectory**

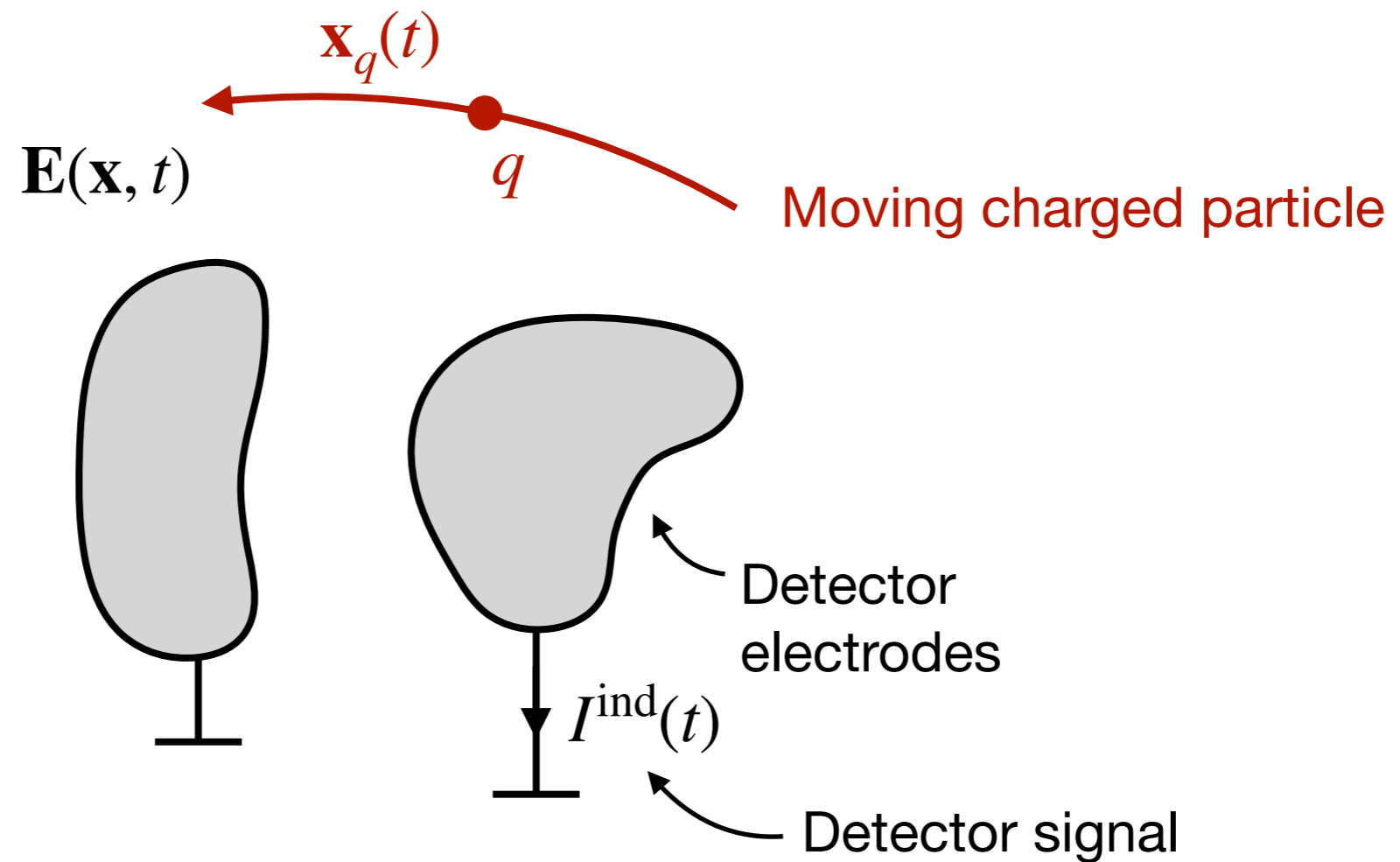

Simple example: strip electrode

Charged particle in front of a grounded strip electrode

(Later: signal on electrodes that are **not** grounded)

- 1.) **Charge creates electric field** (assume charge moves slowly \rightarrow electrostatics)
- 2.) **Electrode builds surface charge density σ** (need to satisfy $\mathbf{E} = \mathbf{0}$ in a conductor)
- 3.) **Total charge Q on strip electrode:** integral over surface charge density
- 4.) **Total current from electrode:** negative change in time of total charge

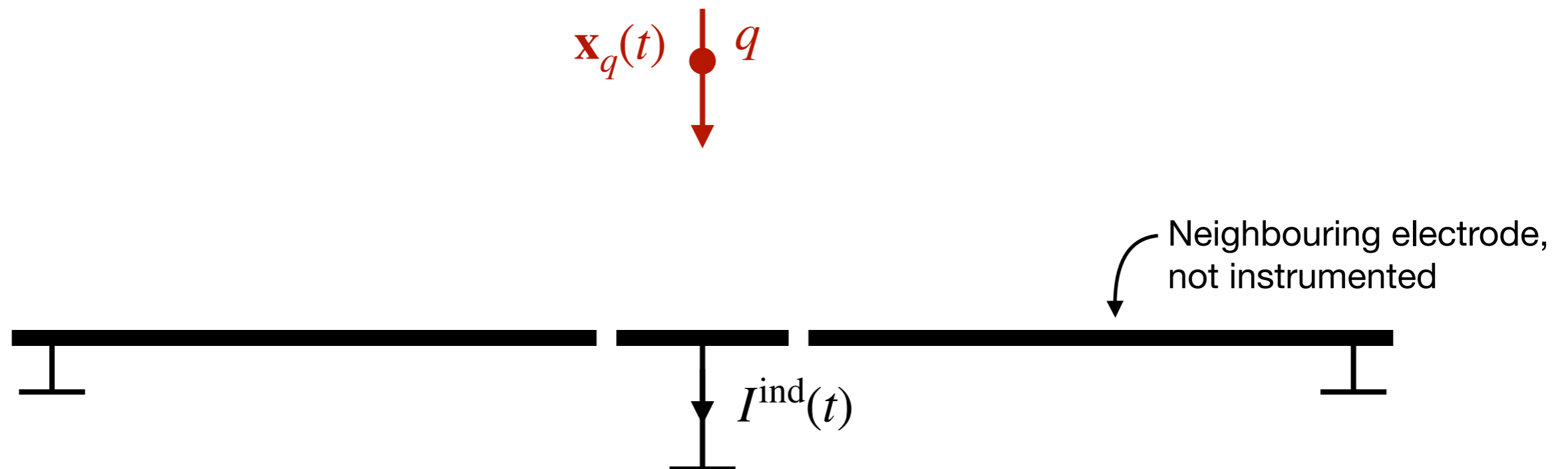

Simple example: strip electrode

Charged particle in front of a grounded strip electrode

(Later: signal on electrodes that are **not** grounded)

- 1.) **Charge creates electric field** (assume charge moves slowly \rightarrow electrostatics)
- 2.) **Electrode builds surface charge density σ** (need to satisfy $\mathbf{E} = \mathbf{0}$ in a conductor)
- 3.) **Total charge Q on strip electrode:** integral over surface charge density
- 4.) **Total current from electrode:** negative change in time of total charge

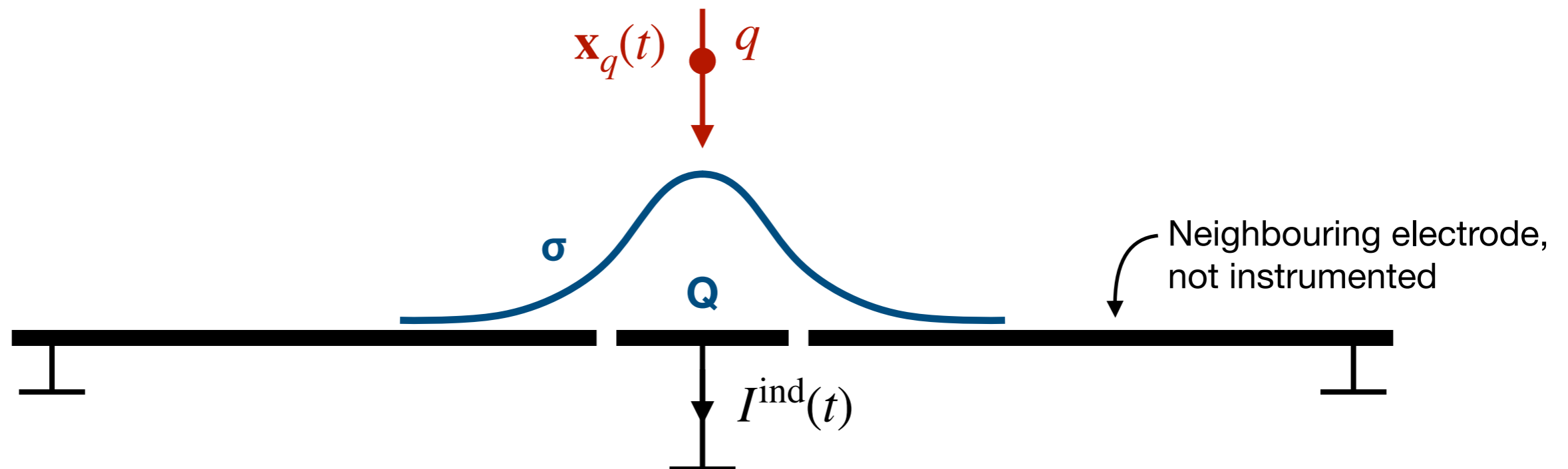

Simple example: strip electrode

Electric field produced by charge

*Narrow gap between strips: electrode appears as infinite **grounded plane***

Compute field with method of image charges:

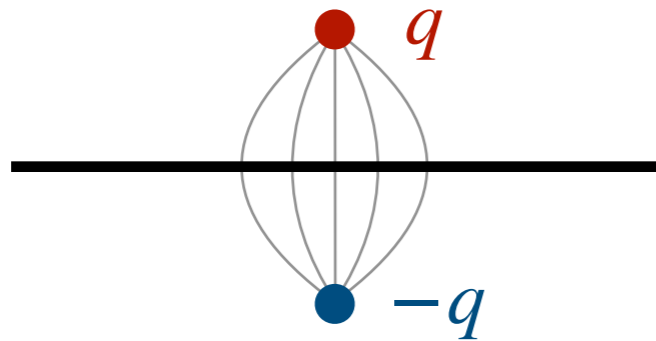

$$E^y(x, z, t) = -\frac{q}{2\pi\epsilon} \frac{y_q(t)}{\left(x^2 + y_q(t)^2 + z^2\right)^{3/2}}$$

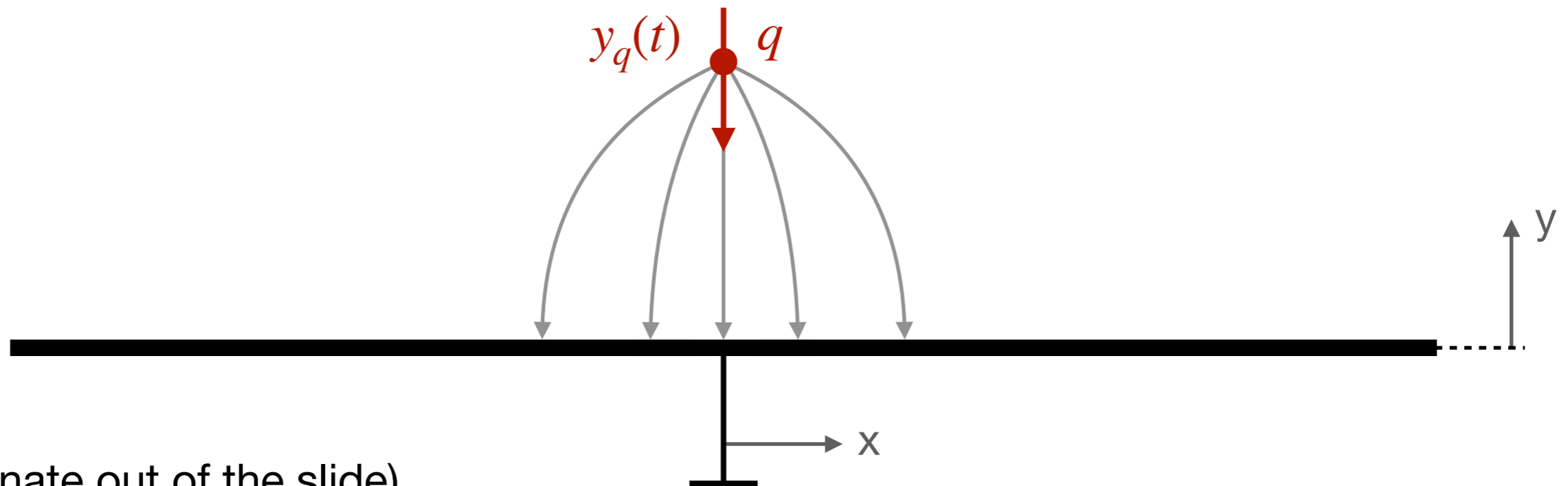

(z coordinate out of the slide)

Simple example: strip electrode

Surface charge density

$$\sigma = \epsilon \mathbf{E} \cdot \hat{\mathbf{n}} = \epsilon E^y$$

Electric field perpendicular to surface

$$\sigma(x, z, t) = -\frac{q}{2\pi} \frac{y_q(t)}{\left(x^2 + y_q(t)^2 + z^2\right)^{3/2}}$$

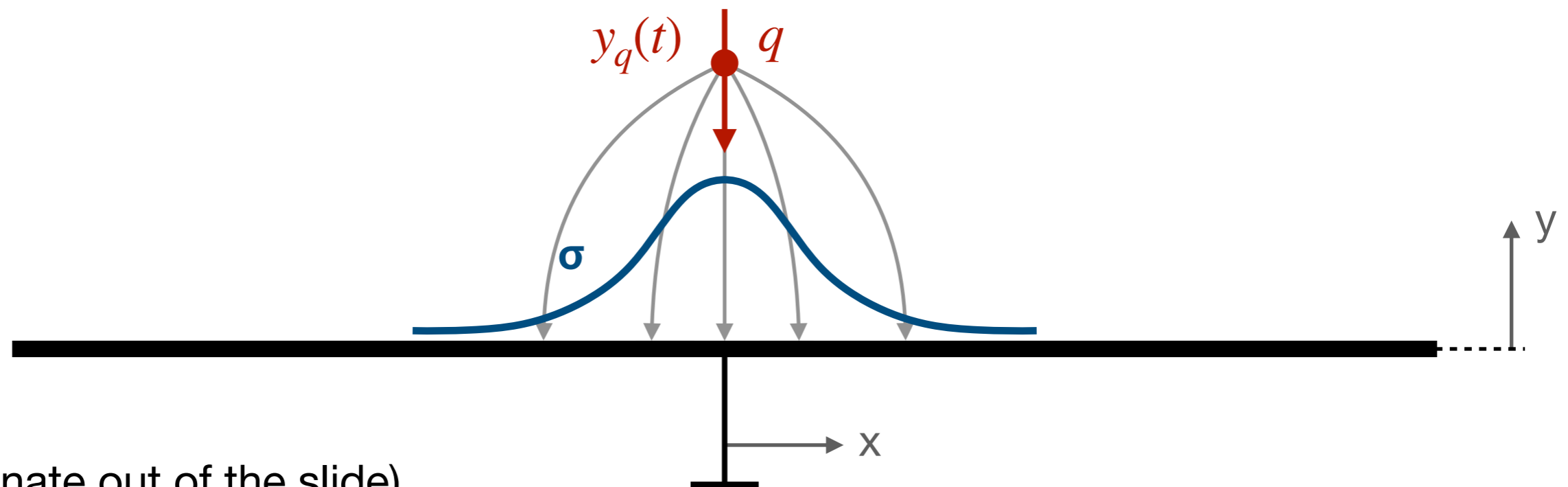

(z coordinate out of the slide)

Simple example: strip electrode

Total charge on strip electrode

$$Q(t) = \int_{-w/2}^{w/2} dx \int_{-\infty}^{\infty} dz \sigma(x, z, t) = -2 \frac{q}{\pi} \arctan \left(\frac{w}{2y_q(t)} \right)$$

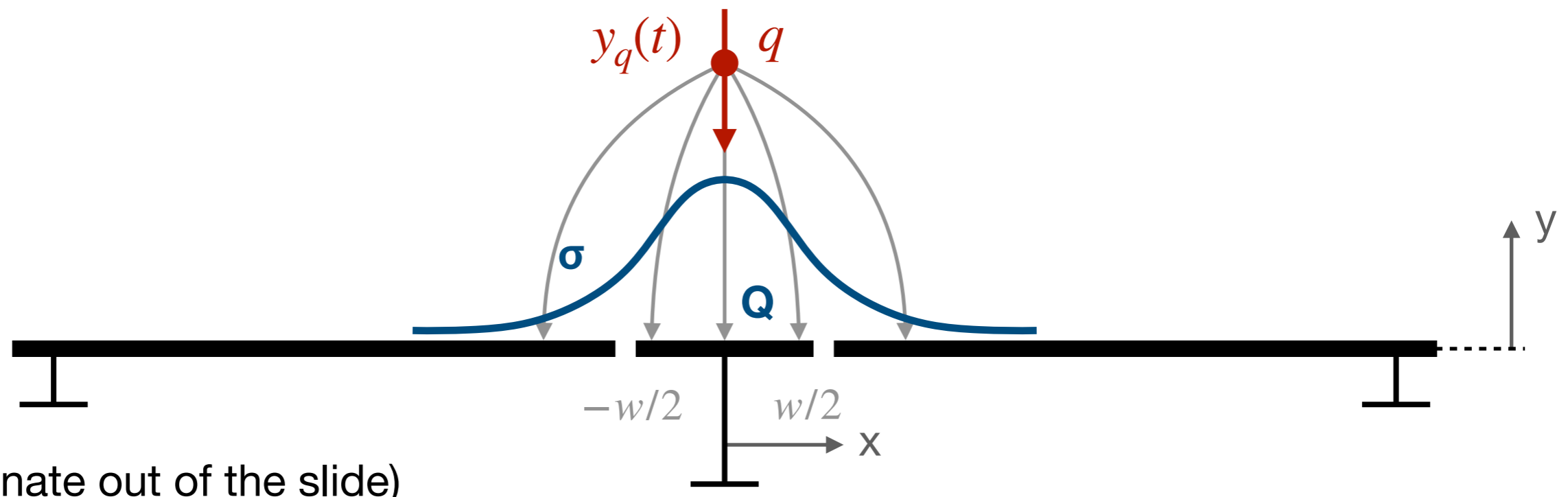

Simple example: strip electrode

Total charge on strip electrode

$$I^{\text{ind}}(t) = -\frac{dQ}{dt} = \frac{4qw}{\pi(w^2 + 4y_q(t)^2)} \cdot \dot{y}_q(t)$$

Detector geometry:
strip width

Particle trajectory:
drift velocity

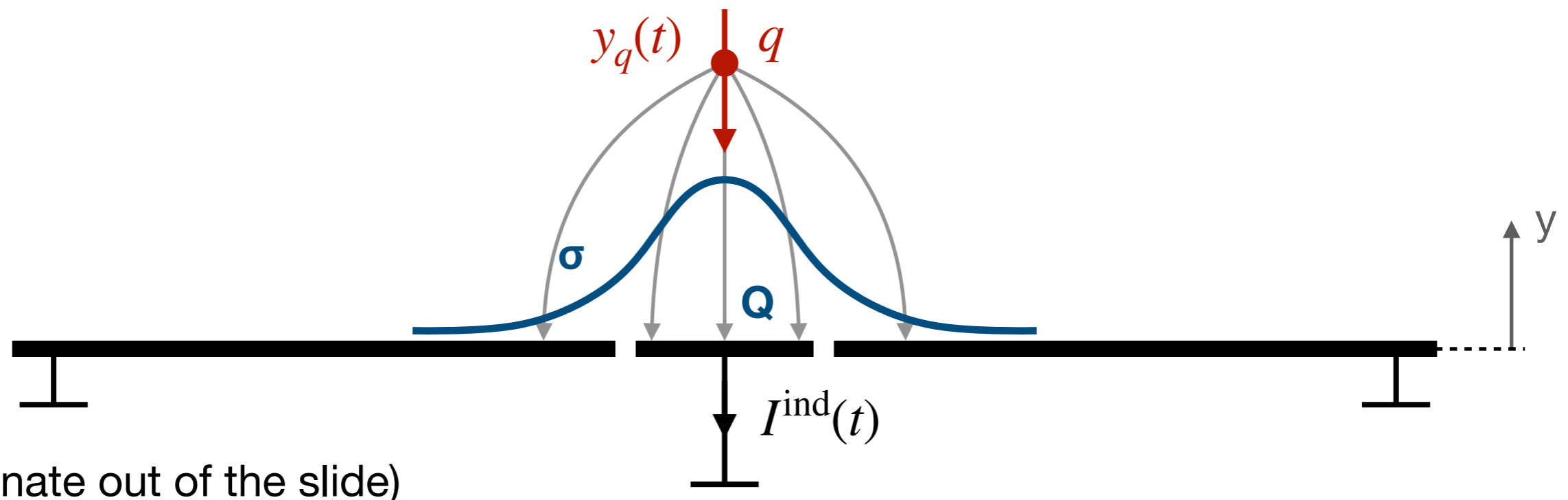

(z coordinate out of the slide)

Properties of the signal

Important properties of the induced signal

Produced by moving charges

Signal amplitude proportional to number of charges and their velocity

Signal ends when charges reach the electrodes

Signal is not due to charge “collection”

*Charges can be far away from the electrodes and still induce a signal
(radio telescopes!)*

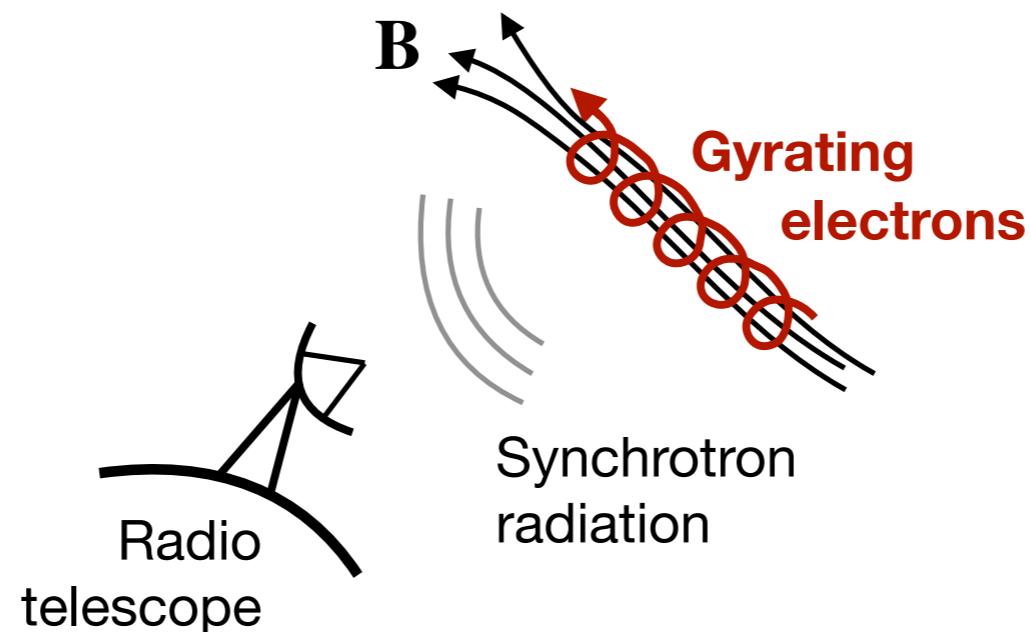

This is a “particle-centric” calculation

Particle trajectory $\mathbf{x}_q(t)$ \rightarrow Maxwell's equations \rightarrow
electric field distribution $\mathbf{E}(\mathbf{x}, t)$ \rightarrow induced signal $I^{\text{ind}}(t)$

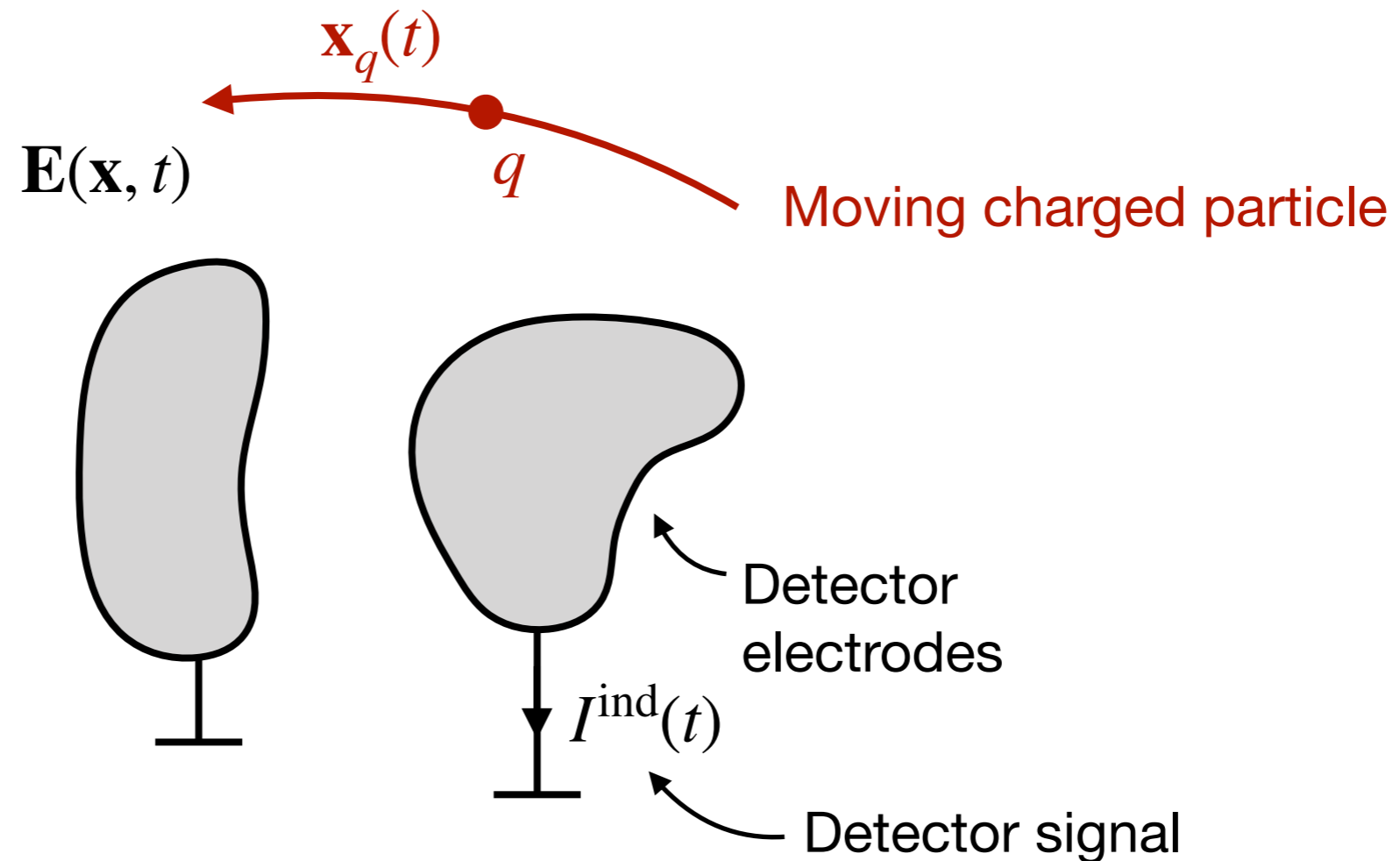

Very computationally expensive!

This is a “particle-centric” calculation

Particle trajectory $\mathbf{x}_q(t)$ \rightarrow Maxwell's equations \rightarrow
electric field distribution $\mathbf{E}(\mathbf{x}, t)$ \rightarrow induced signal $I^{\text{ind}}(t)$

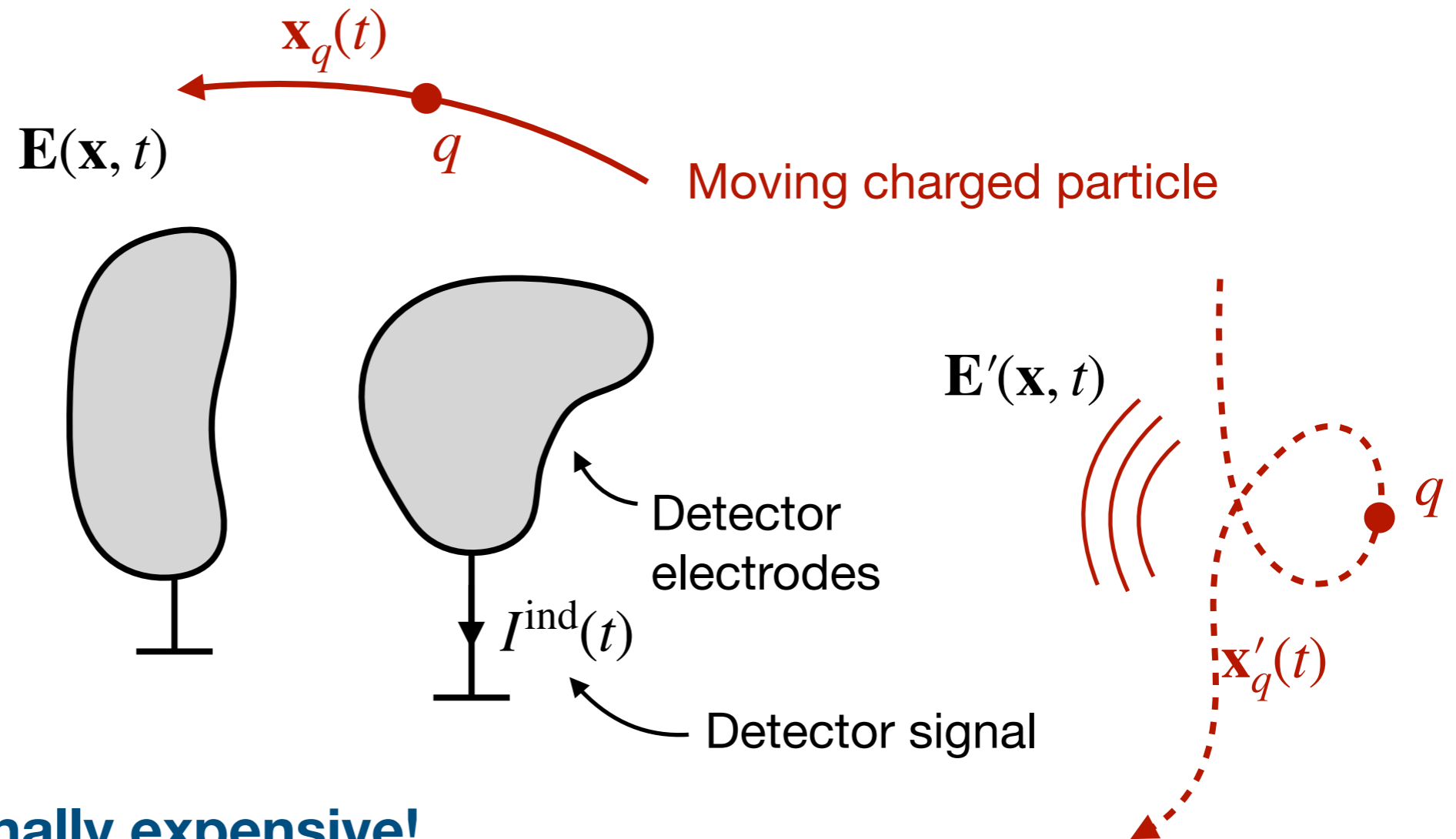

Very computationally expensive!

*(Need to repeat full calculation
for every trajectory.)*

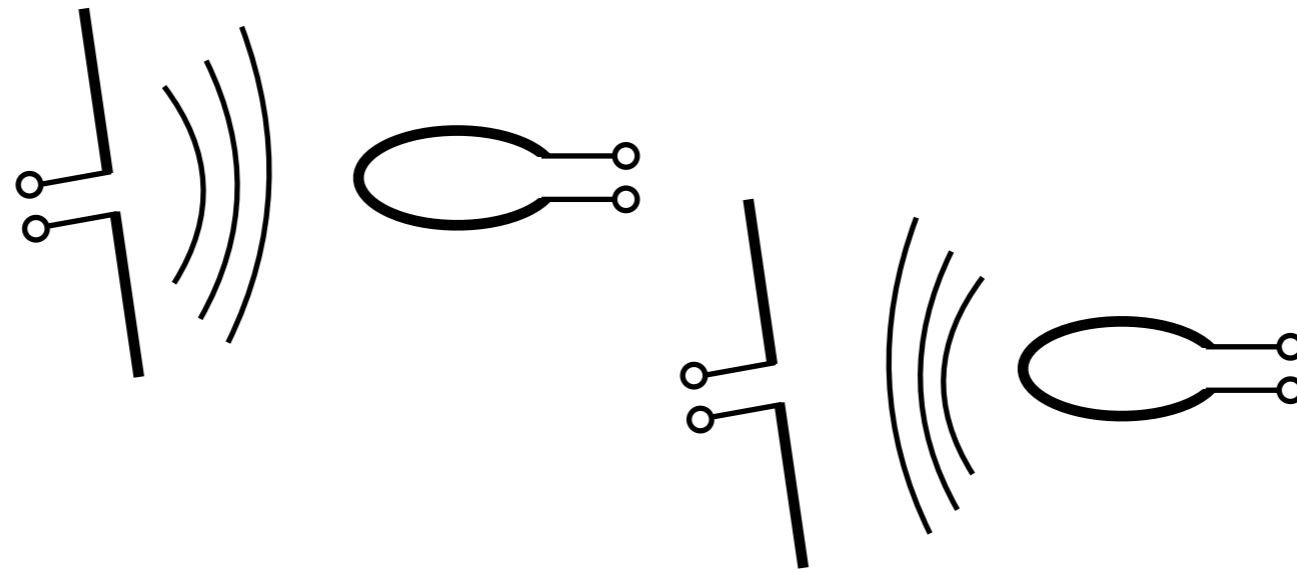

A general and efficient method
to compute the signal

Towards a “detector-centric” calculation

Reciprocity: electrodynamics has a built-in method to relate two different situations (with identical geometry)



Antenna 2 “sees” antenna 1

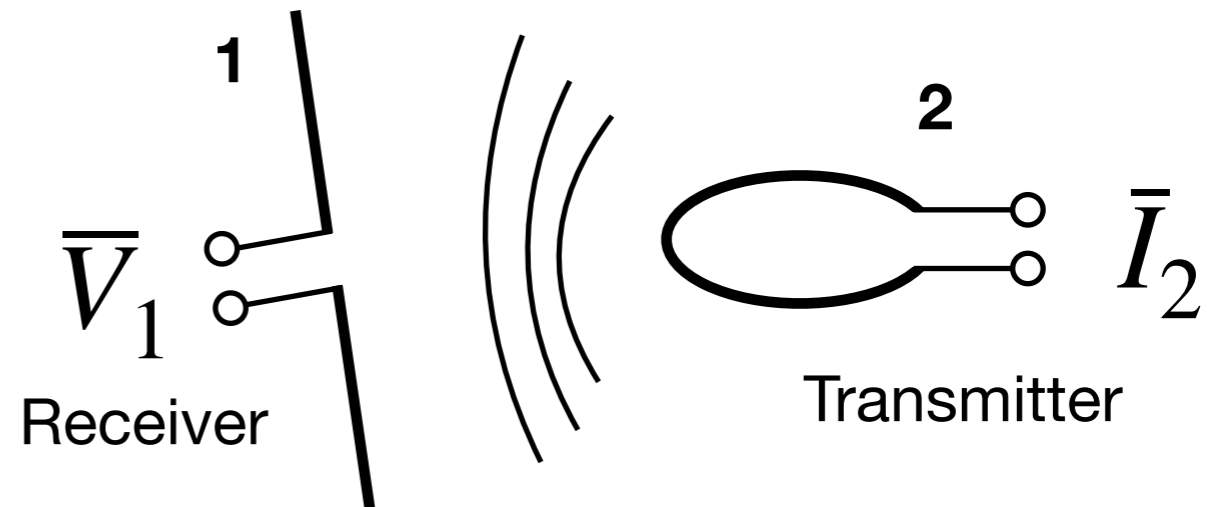

Antenna 1 “sees” antenna 2

Reciprocity:

$$V_2/I_1 = \bar{V}_1/\bar{I}_2$$

Two views of the same situation

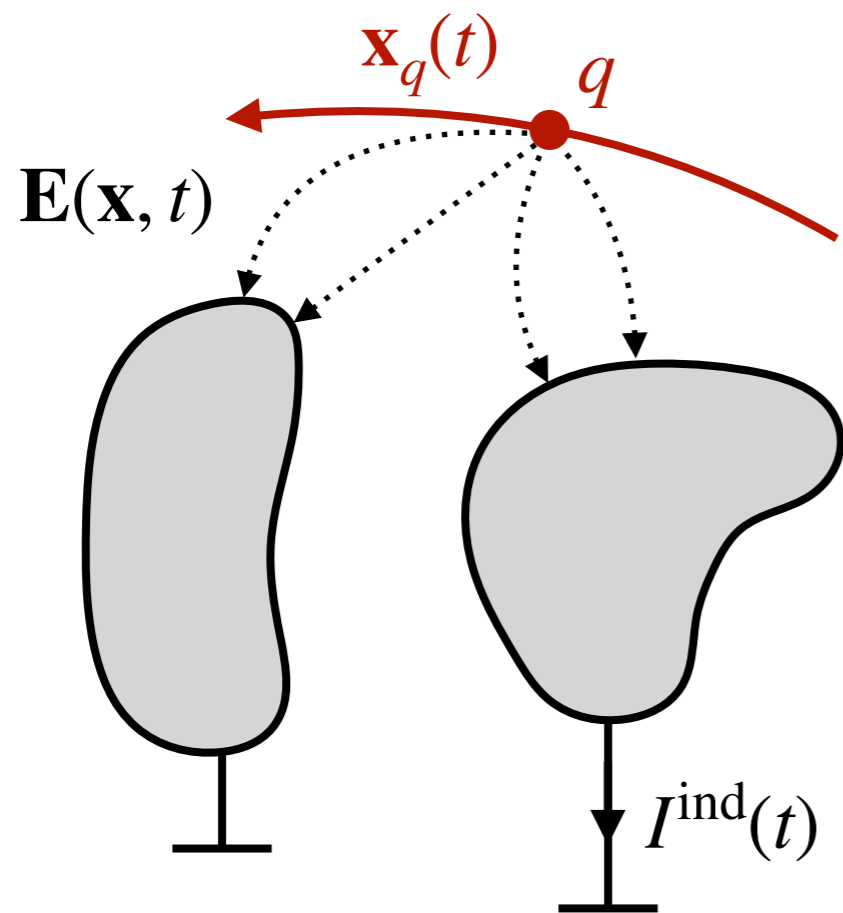

**Detector electrode
“sees” particle**

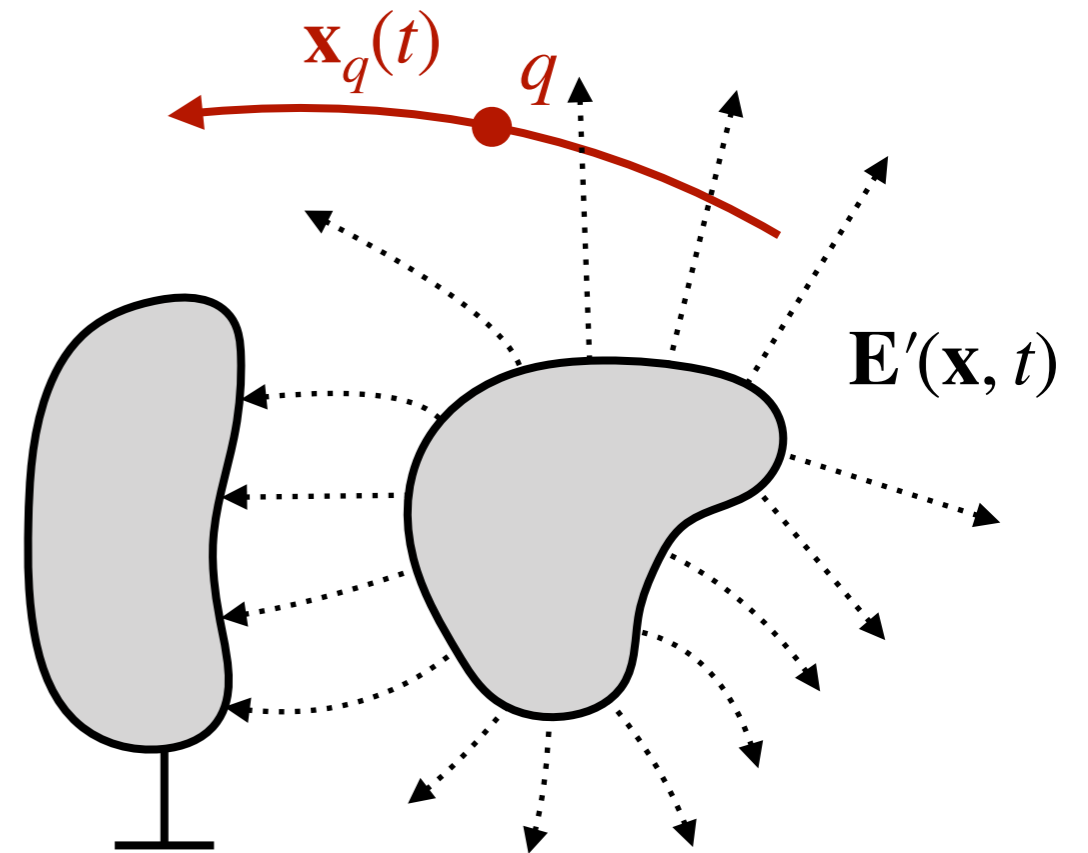

**Particle “sees”
detector electrode**

Towards a “detector-centric” calculation

Reciprocity: electrodynamics has a built-in method to relate two different situations (*with identical geometry*)

General, linear material distribution: $\epsilon(\mathbf{x})$, $\mu(\mathbf{x})$, $\sigma(\mathbf{x})$
(taken to be symmetric for simplicity)

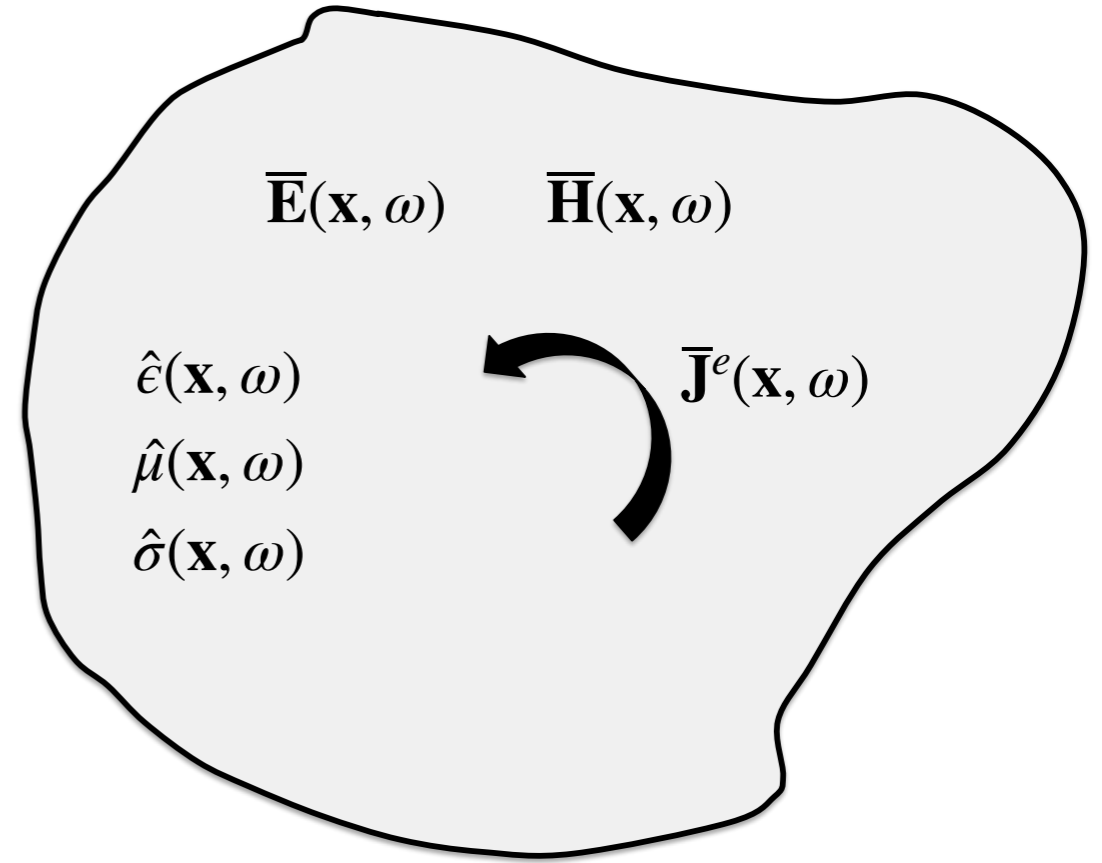
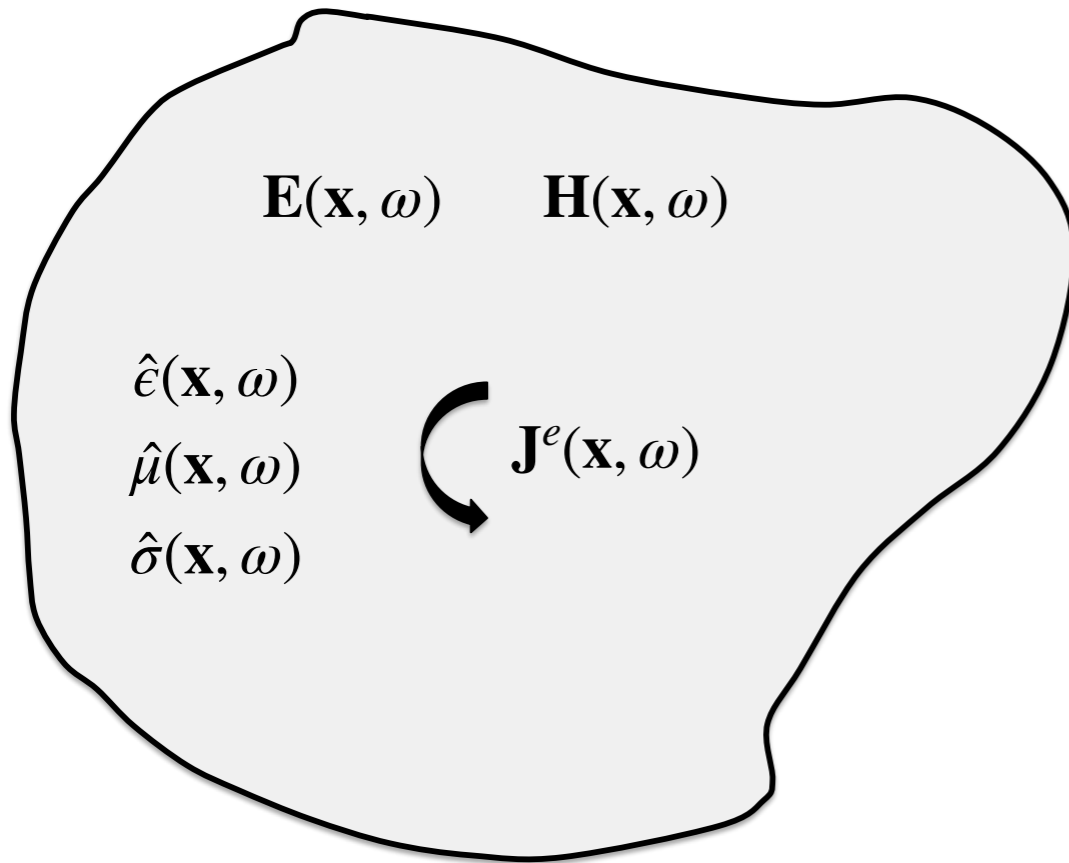

$$\mathbf{J}^e \xrightarrow{\text{Maxwell's eqns.}} \mathbf{E}, \mathbf{H}$$

External current distribution

Field distributions

$$\bar{\mathbf{J}}^e \xrightarrow{\text{Maxwell's eqns.}} \bar{\mathbf{E}}, \bar{\mathbf{H}}$$

External current distribution

Field distributions

Towards a “detector-centric” calculation

Reciprocity: electrodynamics has a built-in method to relate two different situations (with identical geometry)

General, linear material distribution: $\epsilon(\mathbf{x})$, $\mu(\mathbf{x})$, $\sigma(\mathbf{x})$
 (taken to be symmetric for simplicity)

These field distributions are not independent!

For arbitrary \mathbf{J}^e , $\bar{\mathbf{J}}^e$:

$$\int_V dV \bar{\mathbf{E}}(\mathbf{x}, \omega) \cdot \mathbf{J}^e(\mathbf{x}, \omega) = \int_V dV \mathbf{E}(\mathbf{x}, \omega) \cdot \bar{\mathbf{J}}^e(\mathbf{x}, \omega)$$

“Lorentz reciprocity” is a direct consequence of Maxwell’s equations
 (see backup)

H.A. Lorentz, Vers. Konig. Akad. Wetensch. 4, 176

$\hat{\epsilon}(\mathbf{x}, \omega)$
 $\hat{\mu}(\mathbf{x}, \omega)$
 $\hat{\sigma}(\mathbf{x}, \omega)$

ω

\mathbf{J}^e $\xrightarrow{\text{Maxwell's eqns.}}$ \mathbf{E}, \mathbf{H}

External current distribution

Field distributions

$\bar{\mathbf{J}}^e$ $\xrightarrow{\text{Maxwell's eqns.}}$ $\bar{\mathbf{E}}, \bar{\mathbf{H}}$

External current distribution

Field distributions

A detector-centric signal theorem

Use reciprocity to compute signal induced in detector

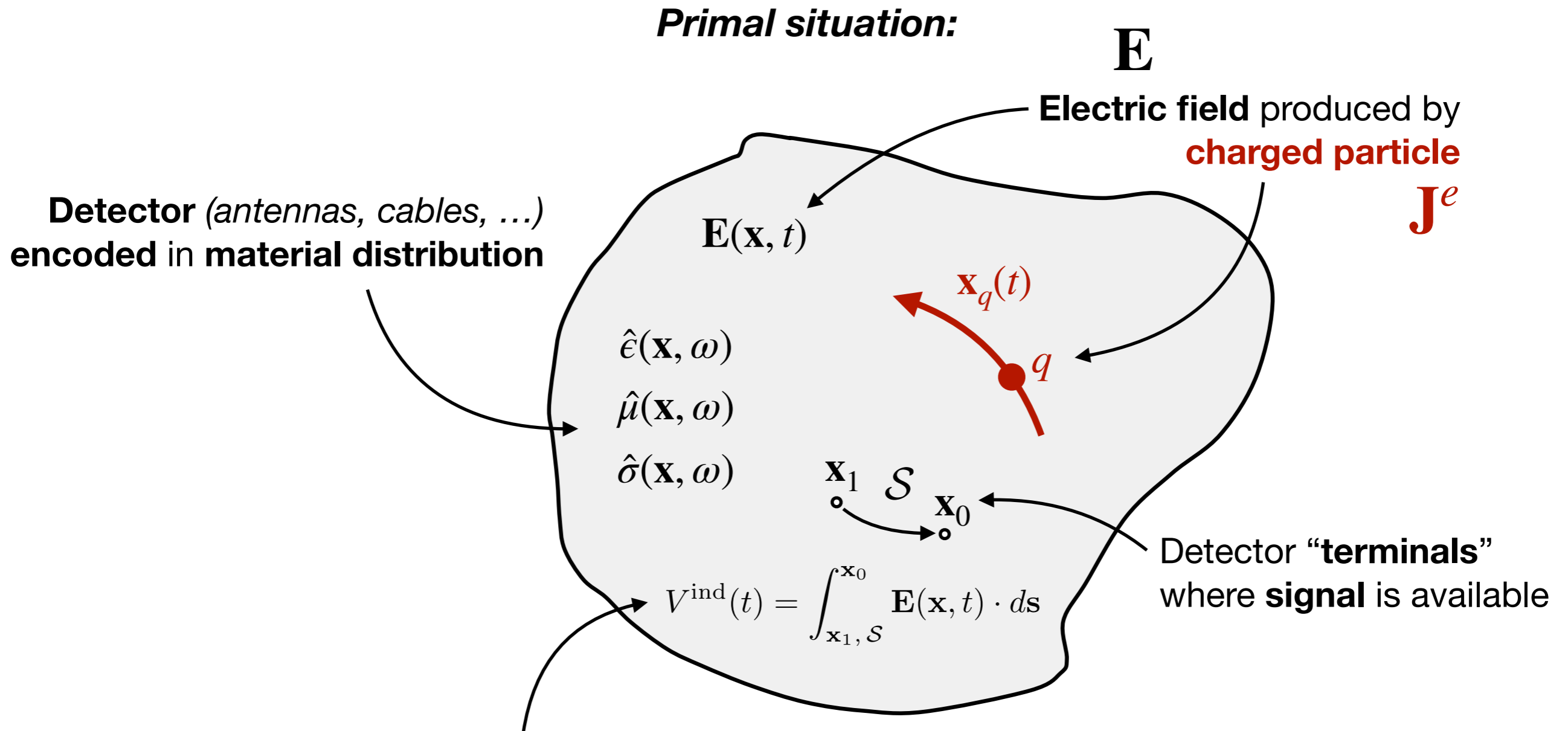

Detector **signal**: energy gain between terminals
(measured along a specific path \mathcal{S} , $\nabla \times \mathbf{E} \neq 0$ in general!)

A detector-centric signal theorem

Use reciprocity to compute signal induced in detector

The “dual” situation:

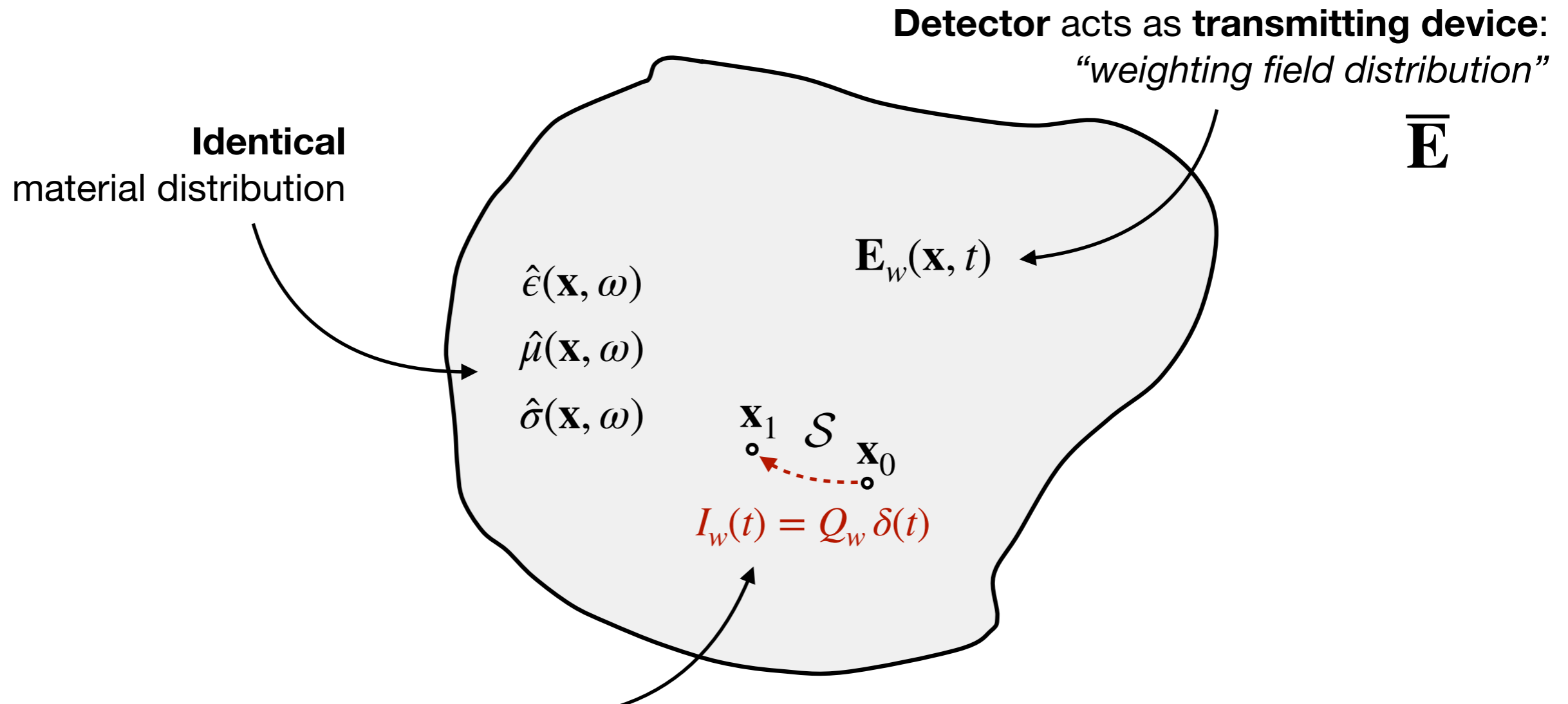

Current source attached to detector terminals: $\bar{\mathbf{J}}^e$
delta-like current along \mathcal{S} (convention: in opposite direction)

A detector-centric signal theorem

Use reciprocity to compute signal induced in detector

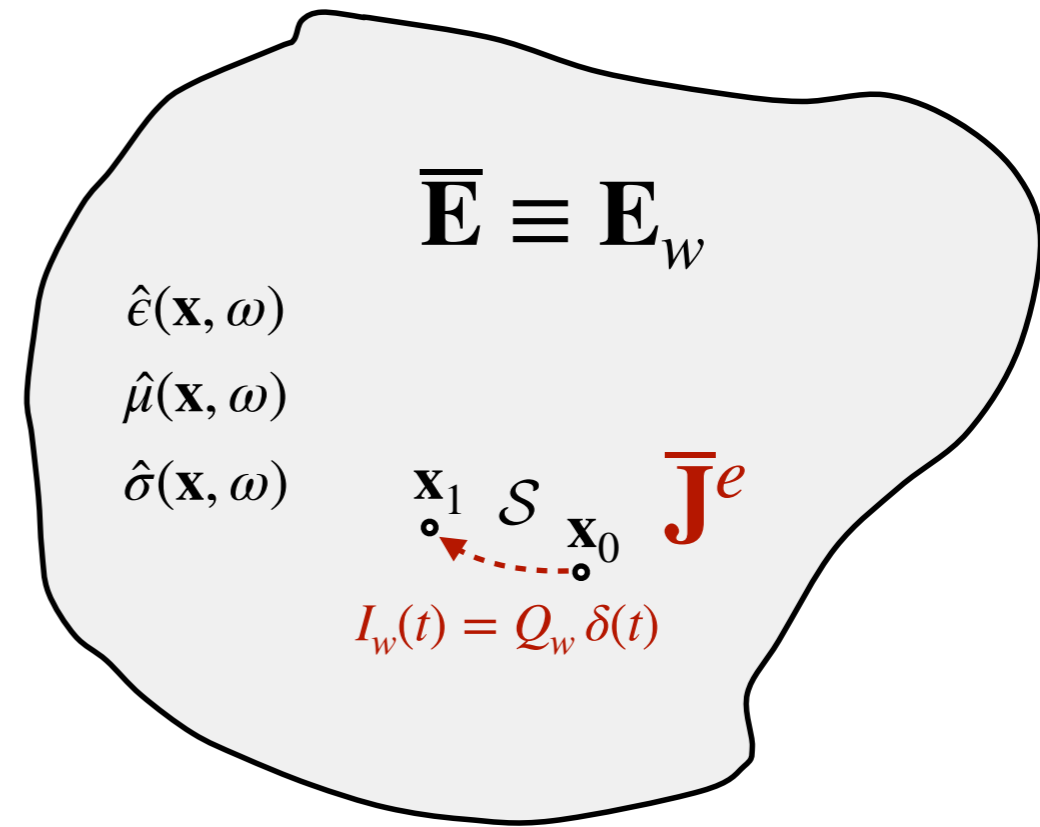
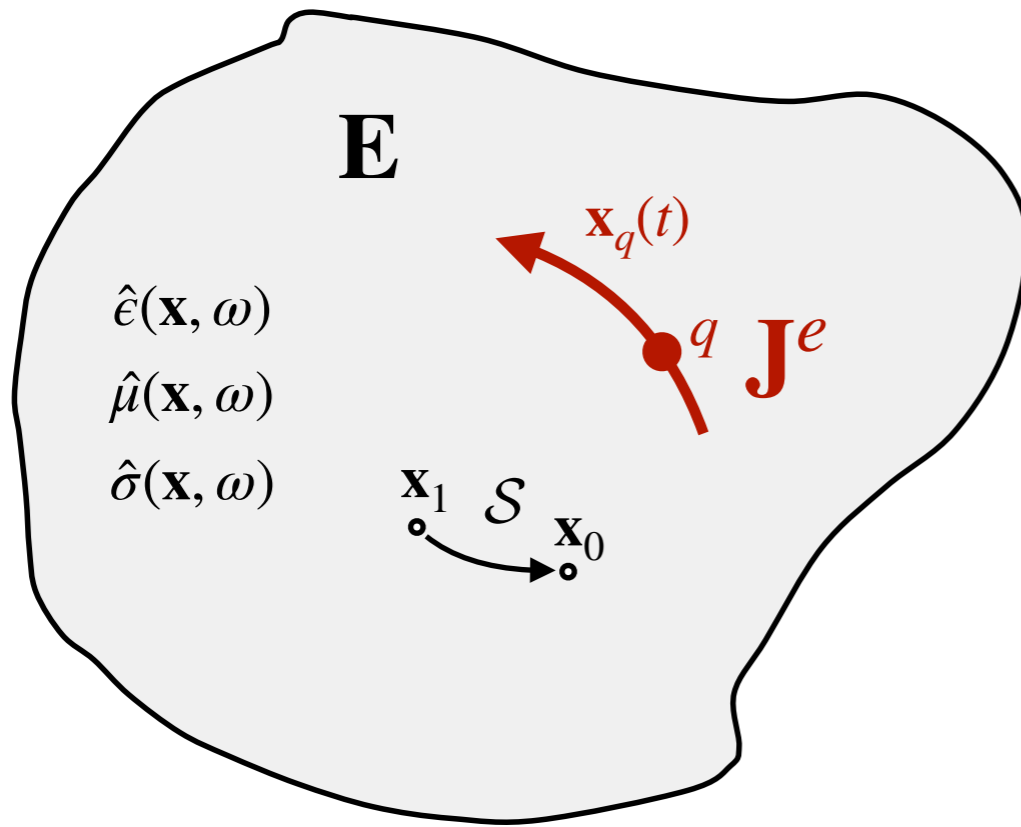

Lorentz reciprocity:
$$\int_V dV \mathbf{E}(\mathbf{x}, \omega) \cdot \bar{\mathbf{J}}^e(\mathbf{x}, \omega) = \int_V dV \bar{\mathbf{E}}(\mathbf{x}, \omega) \cdot \mathbf{J}^e(\mathbf{x}, \omega)$$

$$-Q_w V^{\text{ind}}(\omega) = \int_V dV \mathbf{E}_w(\mathbf{x}, \omega) \cdot \mathbf{J}^e(\mathbf{x}, \omega)$$

A detector-centric signal theorem

In the time domain:

*“Induced signal = weighting field * particle trajectory”*

$$V^{\text{ind}}(t) = -\frac{q}{Q_w} \int_{-\infty}^{\infty} dt' \mathbf{E}_w(\mathbf{x}_q(t'), t - t') \cdot \dot{\mathbf{x}}_q(t')$$

Normalising constant Weighting field Particle trajectory

Weighting field: Green's function for detector signal

Encodes information about detector geometry and environment

Reciprocity: compute it by using detector as transmitter (Maxwell solver)

Compute once, use for arbitrary particle trajectories

(Numerical convolution is cheap!)

Fully general, no approximations

*Holds exactly for all linear, anisotropic materials,
approximately for nonlinear, anisotropic materials*

Nonrelativistic limit

Charges move nonrelativistically in a typical detector (gas, silicon)

Quasi-electrostatics ($c \rightarrow \infty$): *no radiation, no propagation effects, ...*

Also: want the induced current (on a grounded electrode)

Primal situation:

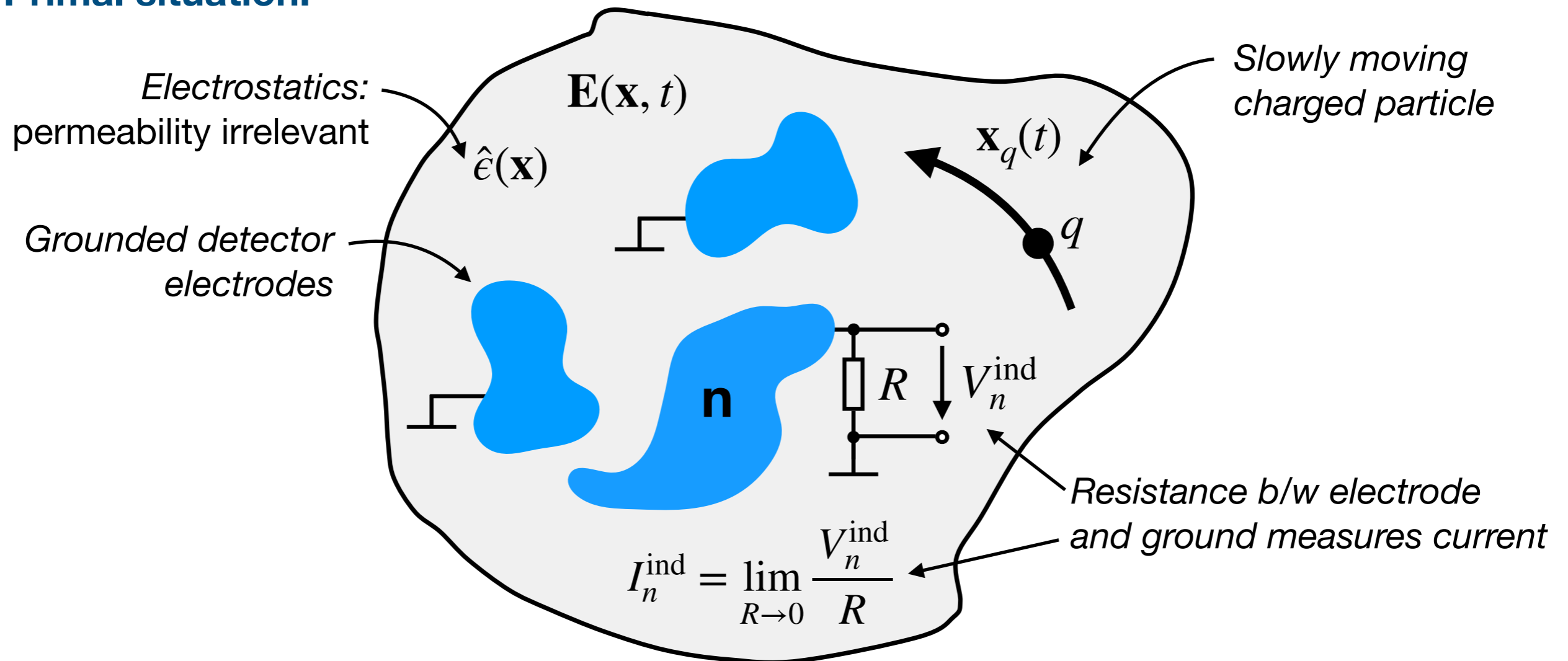

Nonrelativistic limit

Charges move nonrelativistically in a typical detector (gas, silicon)

Quasi-electrostatics ($c \rightarrow \infty$): *no radiation, no propagation effects, ...*

Also: want the induced current (on a grounded electrode)

Dual situation:

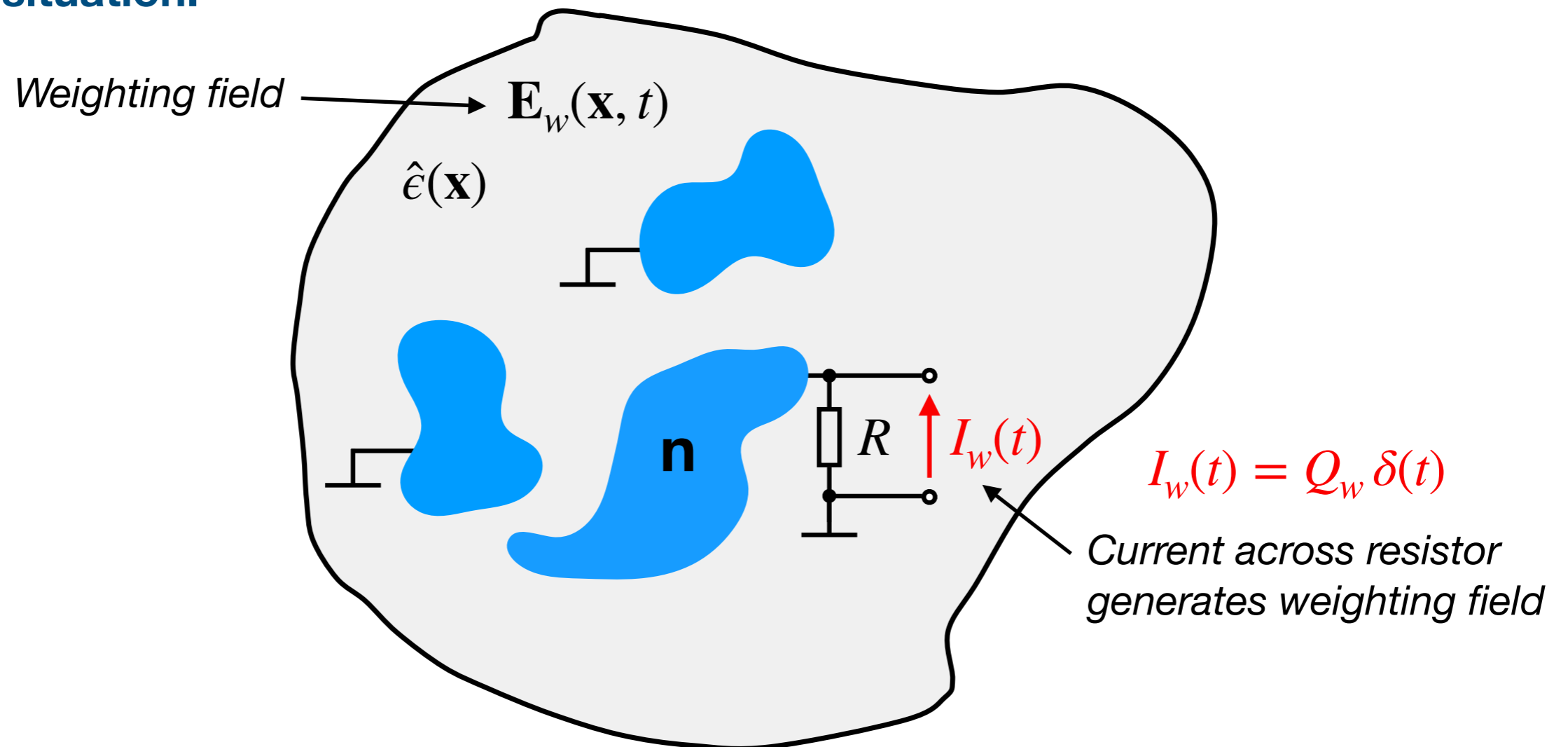

Weighting field

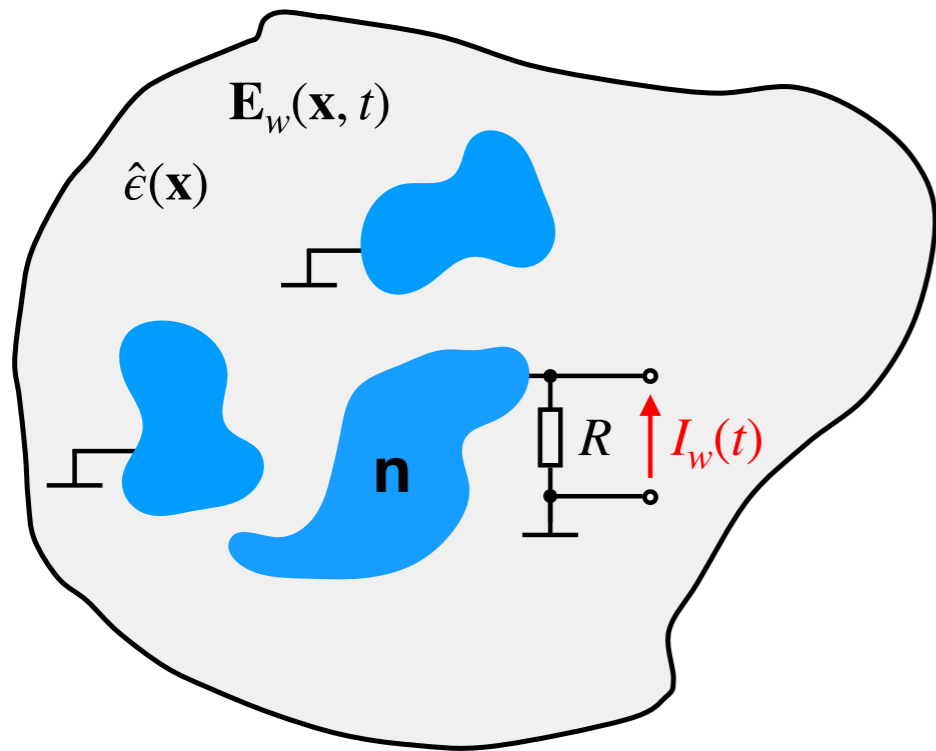

1.) The current I_w places a charge Q_w on electrode n at $t = 0$

$$I_w(t) = Q_w \delta(t)$$

2.) This puts the electrode at potential $V(0)$ and generates the electric field $\mathbf{E}_w(\mathbf{x}, t)$

3.) The electrode discharges through the resistor R for $t > 0$
 → time-dependent potential $V(t)$

Quasi-electrostatic limit: evolution is sequence of electrostatic configurations

If the field is $\mathbf{E}_n(\mathbf{x}; V)$ for electrode n at potential V , the weighting field is

$$\mathbf{E}_w(\mathbf{x}, t) = \mathbf{E}_n(\mathbf{x}; V(t)) = \frac{V(t)}{V_w} \mathbf{E}_n(\mathbf{x}; V_w)$$

Arbitrary constant

(Field scales homogeneously with the potential)

Induced voltage

Weighting field:

$$\mathbf{E}_w(\mathbf{x}, t) = \frac{V(t)}{V_w} \mathbf{E}_n(\mathbf{x}; V_w)$$

Signal theorem:

$$V^{\text{ind}}(t) = -\frac{q}{Q_w} \int_{-\infty}^{\infty} dt' \mathbf{E}_w(\mathbf{x}_q(t'), t-t') \cdot \dot{\mathbf{x}}_q(t')$$

Induced current:

$$I^{\text{ind}}(t) = \lim_{R \rightarrow 0} \frac{V^{\text{ind}}(t)}{R}$$

$$\implies I^{\text{ind}}(t) = \lim_{R \rightarrow 0} -\frac{q}{Q_w R} \int dt' \frac{V_n(t-t')}{V_w} \mathbf{E}_n(\mathbf{x}_q(t'); V_w) \cdot \dot{\mathbf{x}}_q(t')$$

The discharge is very fast
for small resistances

$$\lim_{R \rightarrow 0} \frac{V_n(t)}{R} = Q_w \delta(t)$$

$$\implies I^{\text{ind}}(t) = -\frac{q}{V_w} \mathbf{E}_n(\mathbf{x}_q(t); V_w) \cdot \dot{\mathbf{x}}_q(t)$$

Induced voltage

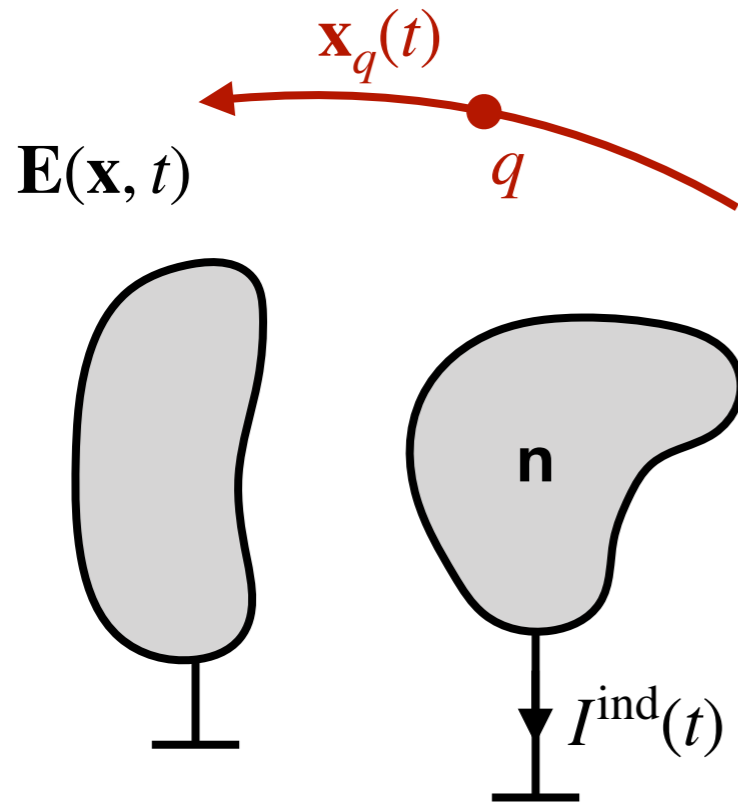

“Detector-centric” expression for current induced on grounded readout electrodes:
(Nonrelativistic limit)

$$I^{\text{ind}}(t) = -\frac{q}{V_w} \mathbf{E}_n(\mathbf{x}_q(t); V_w) \cdot \dot{\mathbf{x}}_q(t)$$

“Ramo-Shockley theorem”

584 *Proceedings of the I.R.E.* September, 1939

Currents Induced by Electron Motion*

SIMON RAMO†, ASSOCIATE MEMBER, I.R.E.

Summary—A method is given for computing the instantaneous current induced in neighboring conductors by a given specified motion of electrons. The method is based on the repeated use of a simple equation giving the current due to a single electron's movement and is believed to be simpler than methods previously described.

The method whose derivation is given in this paper is based on the repeated use of a simple equation giving the current due to a single electron's movement and is believed to be simpler than methods previously described.

Derived in the 1930s by Ramo and Shockley ...

Currents to Conductors Induced by a Moving Point Charge

W. SHOCKLEY
Bell Telephone Laboratories, Inc., New York, N. Y.
(Received May 14, 1938)

General expressions are derived for the currents which flow in the external circuit connecting a system of conductors when a point charge is moving among the conductors. The results are applied to obtain explicit expressions for several cases of practical interest.

... specifically for the quasi-static case

Induced voltage

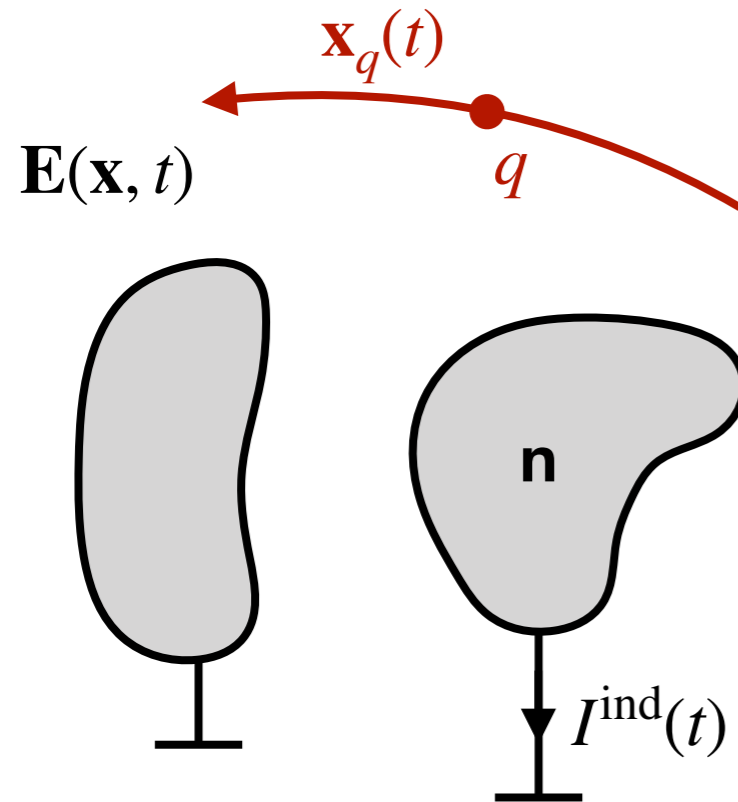

“Detector-centric” expression for current induced on grounded readout electrodes:
(Nonrelativistic limit)

$$I^{\text{ind}}(t) = -\frac{q}{V_w} \mathbf{E}_n(\mathbf{x}_q(t); V_w) \cdot \dot{\mathbf{x}}_q(t)$$

“Ramo-Shockley theorem”

Weighting field

Encodes detector geometry, can be computed once and for all

Particle trajectory

Nonzero velocity is required to produce a nonzero signal

Very efficient! Multiplication instead of Poisson equation ...

Grounded electrodes?

Real detector electrodes are embedded in electrical circuits

Insulation resistance, frontend electronics ...

Primal situation:

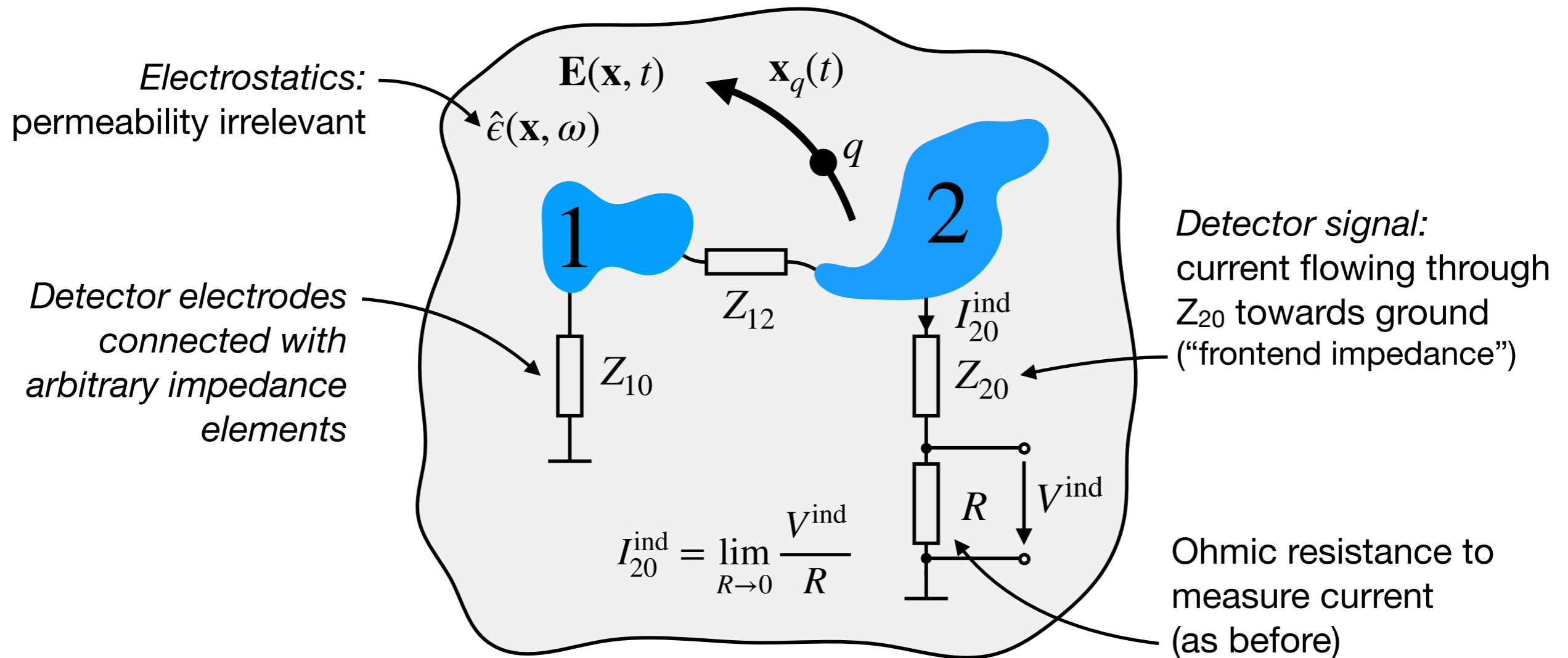

Grounded electrodes?

Real detector electrodes are embedded in electrical circuits

Insulation resistance, frontend electronics ...

Dual situation:

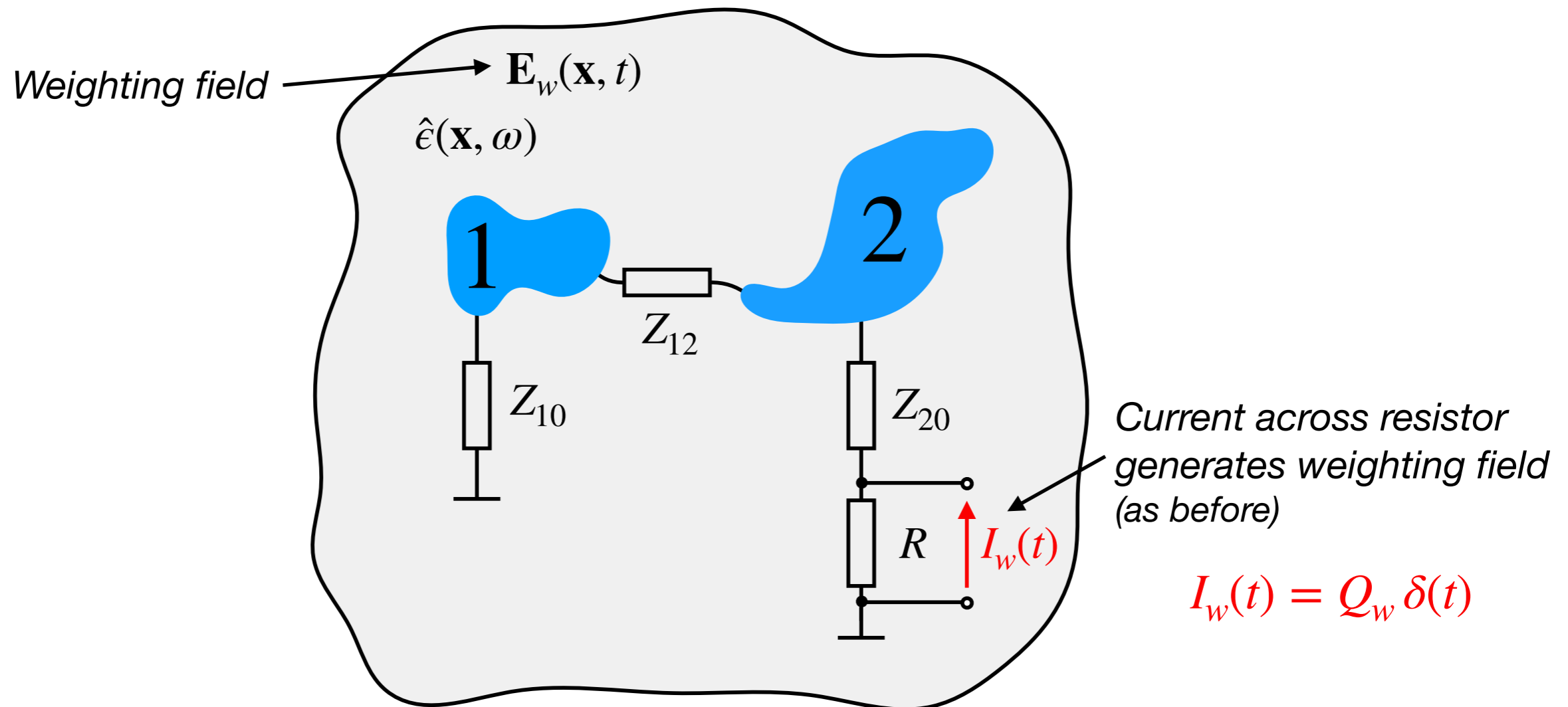

Induced signal

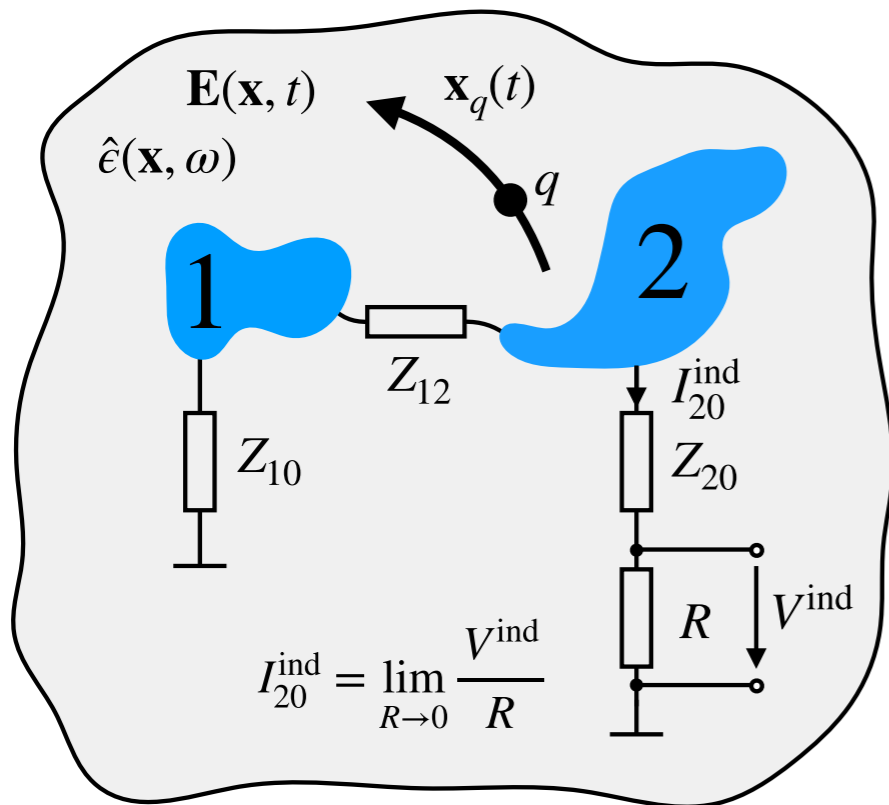

Derivation works as before:

$$\mathbf{E}_w(\mathbf{x}, t) = \frac{V_2(t)}{V_w} \mathbf{E}_2(\mathbf{x}; V_w)$$

Evolution of $V_2(t)$ now depends on the equivalent circuit of the situation

Equivalent circuit:

Explicit representation of circuit including mutual capacitances between electrodes

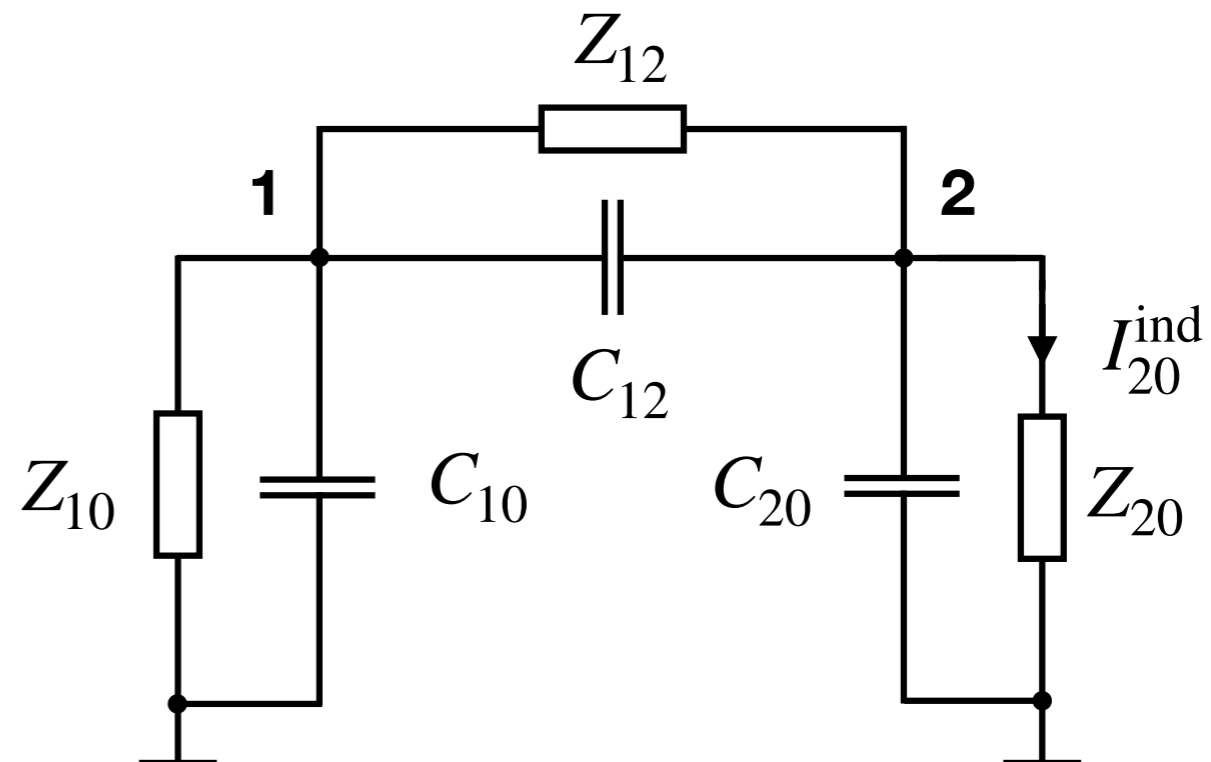

Induced signal

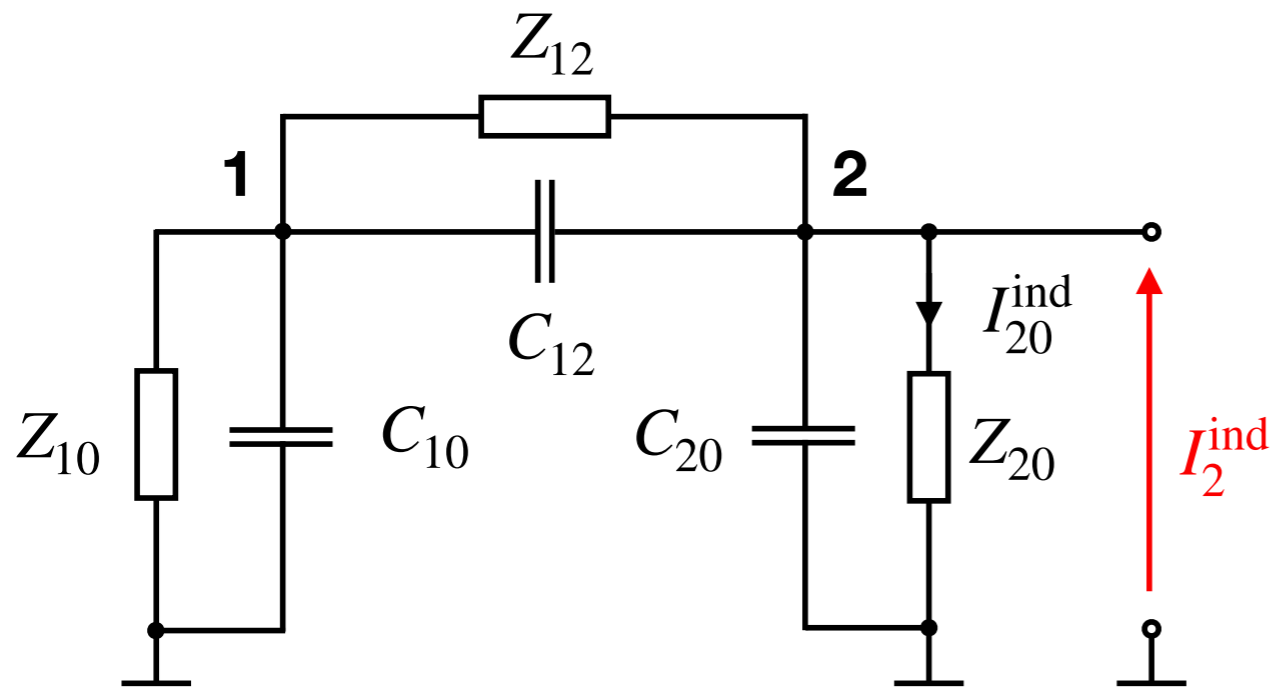

Result of derivation:

$$\lim_{R \rightarrow 0} I_{20}^{\text{ind}}(t) = g(t) * I_2^{\text{ind}}(t)$$

Green's function of equivalent circuit

Convolution

Current induced on grounded electrode

Practical workflow:

- 1.) Compute current $I_2^{\text{ind}}(t)$ induced on grounded electrode with Ramo-Shockley theorem
- 2.) Place this current as a source into equivalent circuit and solve with SPICE (or other simulator), read off $I_{20}^{\text{ind}}(t)$

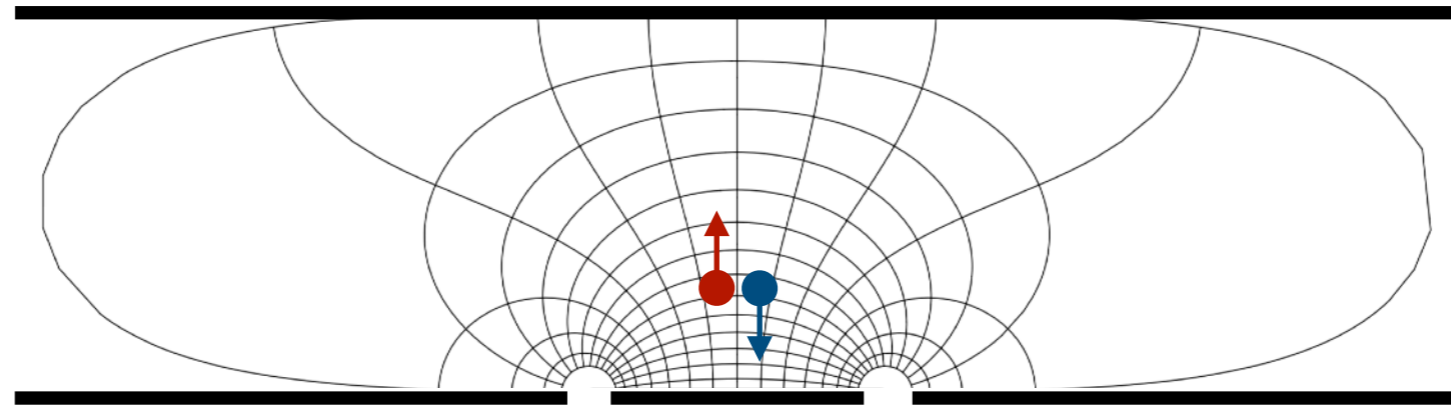

Signals in silicon detectors

Signals in silicon detectors

Shape of signals in silicon detectors determined by



**Structure of
weighting field**



Geometry of electrodes:
Pixels, strips, ...



**Trajectories of
moving charges**



Electric field in detector
Drift trajectories,
avalanche multiplication, ...

In the following: discuss some common situations

Parallel-plate geometry

(e.g. silicon pixel detector with large pitch)



Parallel-plate geometry

(e.g. silicon pixel detector with large pitch)



Weighting field for electrode 1: $\mathbf{E}_1 = \frac{V_w}{d} \hat{\mathbf{y}}$

Signal induced by electron-hole pair

(e.g. silicon pixel detector with large pitch)

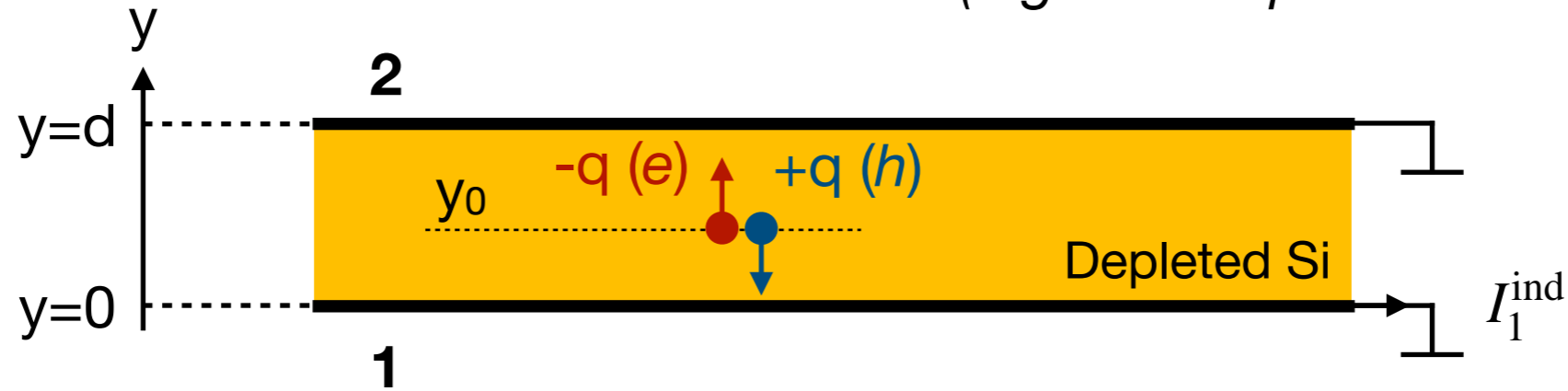

Weighting field for electrode 1: $\mathbf{E}_1 = \frac{V_w}{d} \hat{y}$

Electron-hole pair deposited at y_0 , drifting in opposite directions:

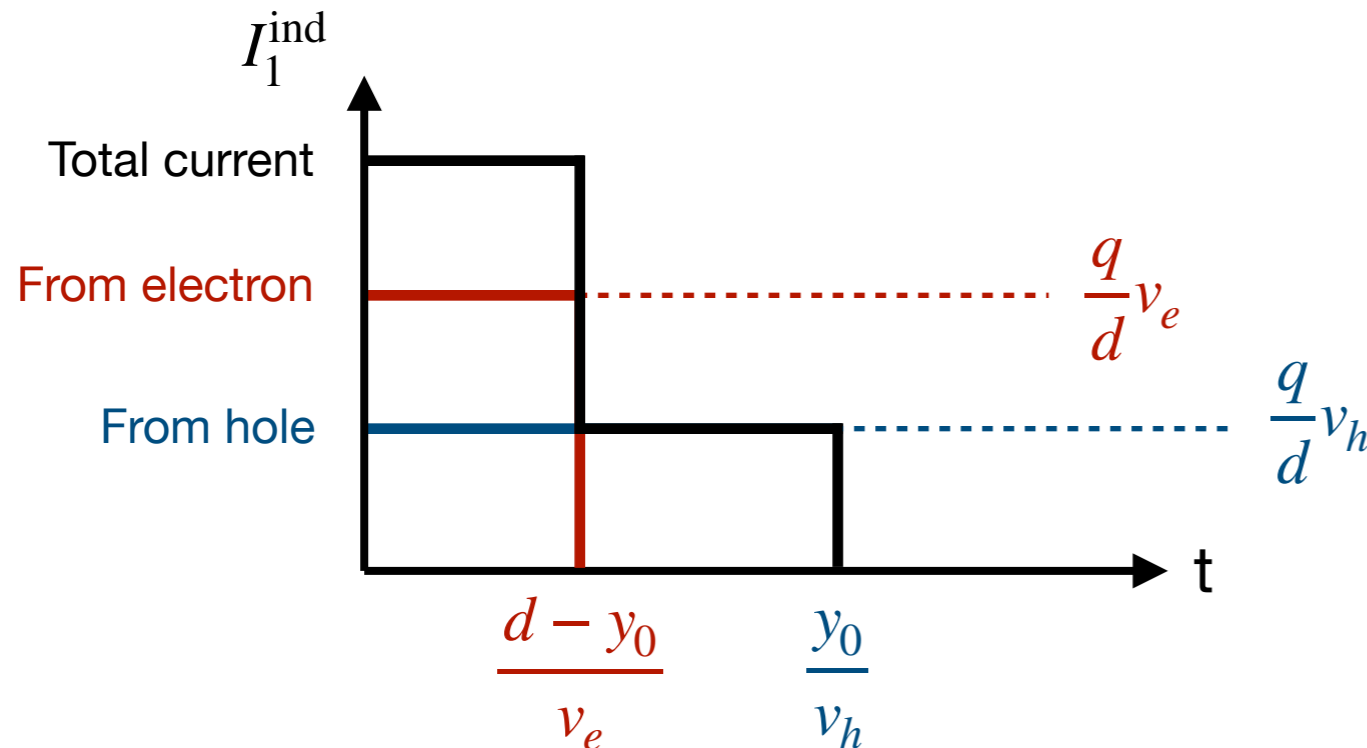

Constant contribution to signal during drift
(electrons drift faster)

Total charge contained in signal:

$$Q_{\text{tot}} = \frac{q}{d} v_e \cdot \frac{d - y_0}{v_e} + \frac{q}{d} v_h \cdot \frac{y_0}{v_h} = q$$

(fraction carried by electrons / holes depends on y_0 !)

Signal induced by charged particle

(e.g. silicon pixel detector with large pitch)

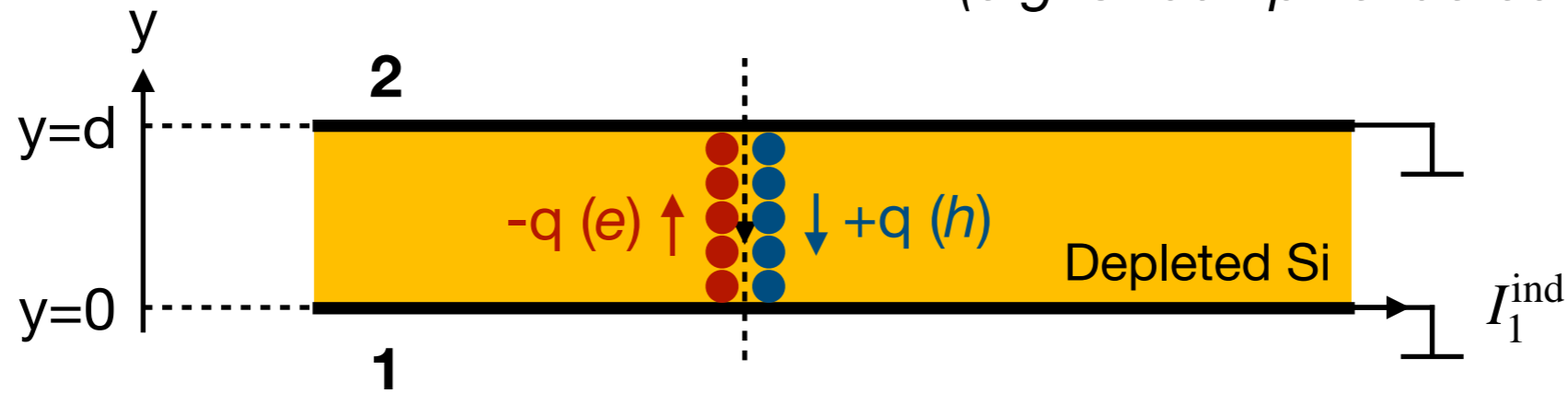

Weighting field for electrode 1: $\mathbf{E}_1 = \frac{V_w}{d} \hat{y}$

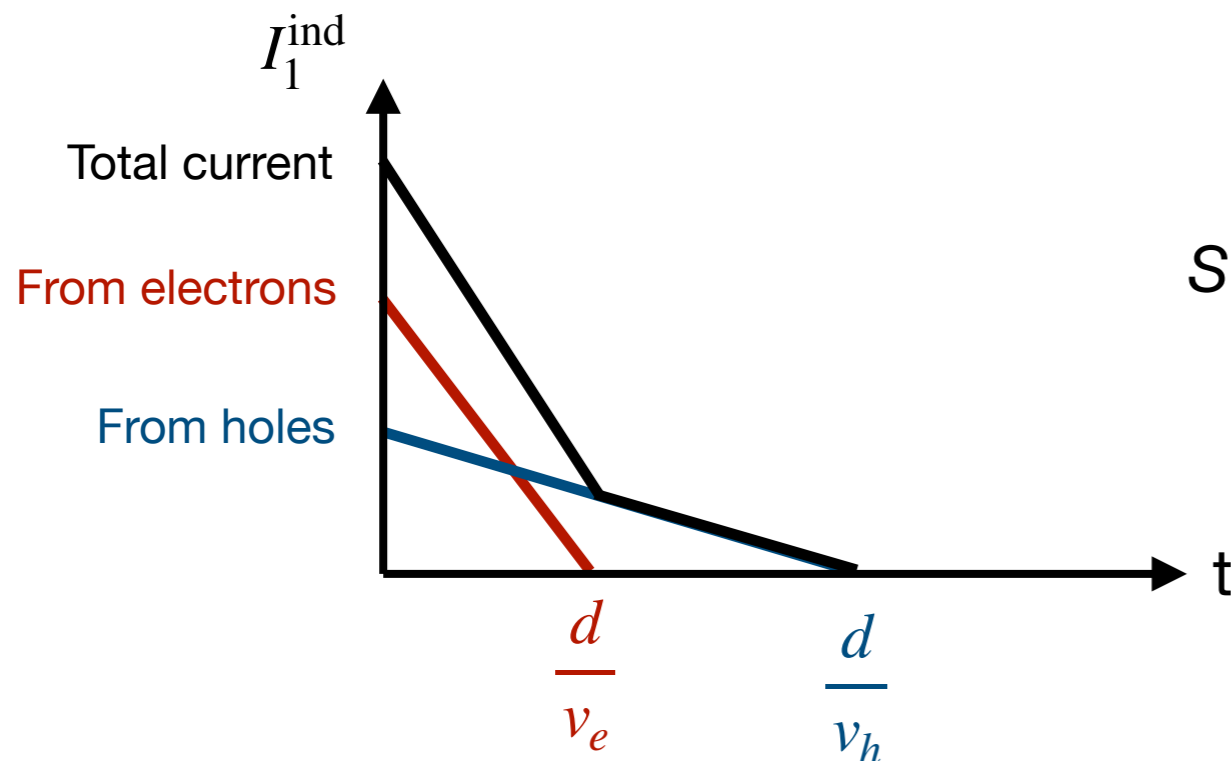

Primary particle deposits two **line charges** (clusters of e/h pairs) along its **track**

Statistics of charge deposit: Karol Krizka's lectures

Number of drifting charges reduces linearly over time → triangular signal

Signals in LGADs

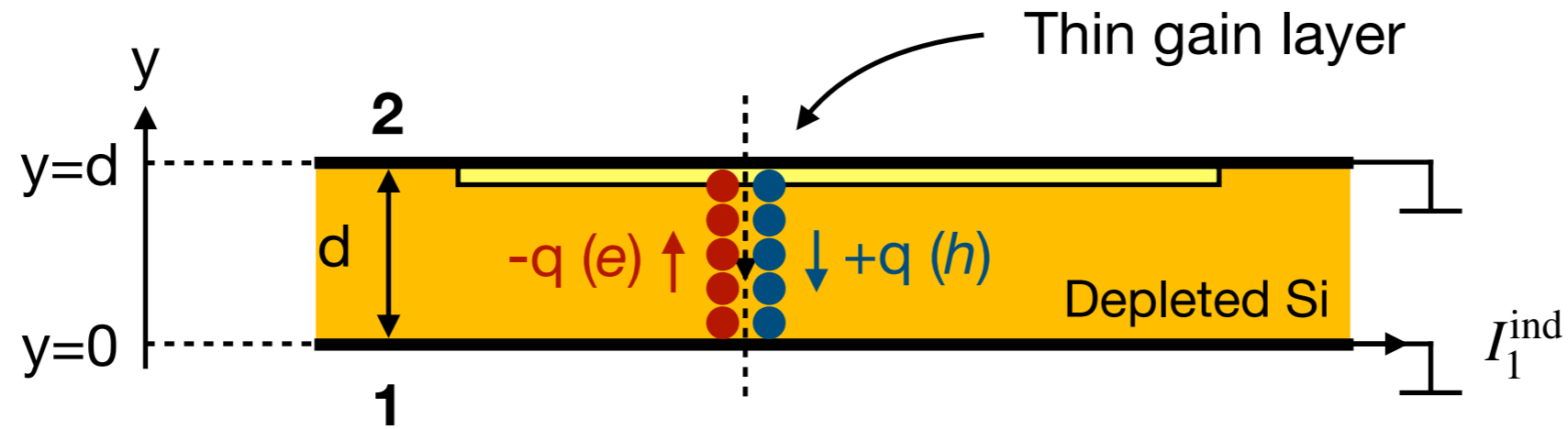

Cartiglia et al., "Design optimization of ultra-fast silicon detectors" [\[link\]](#)

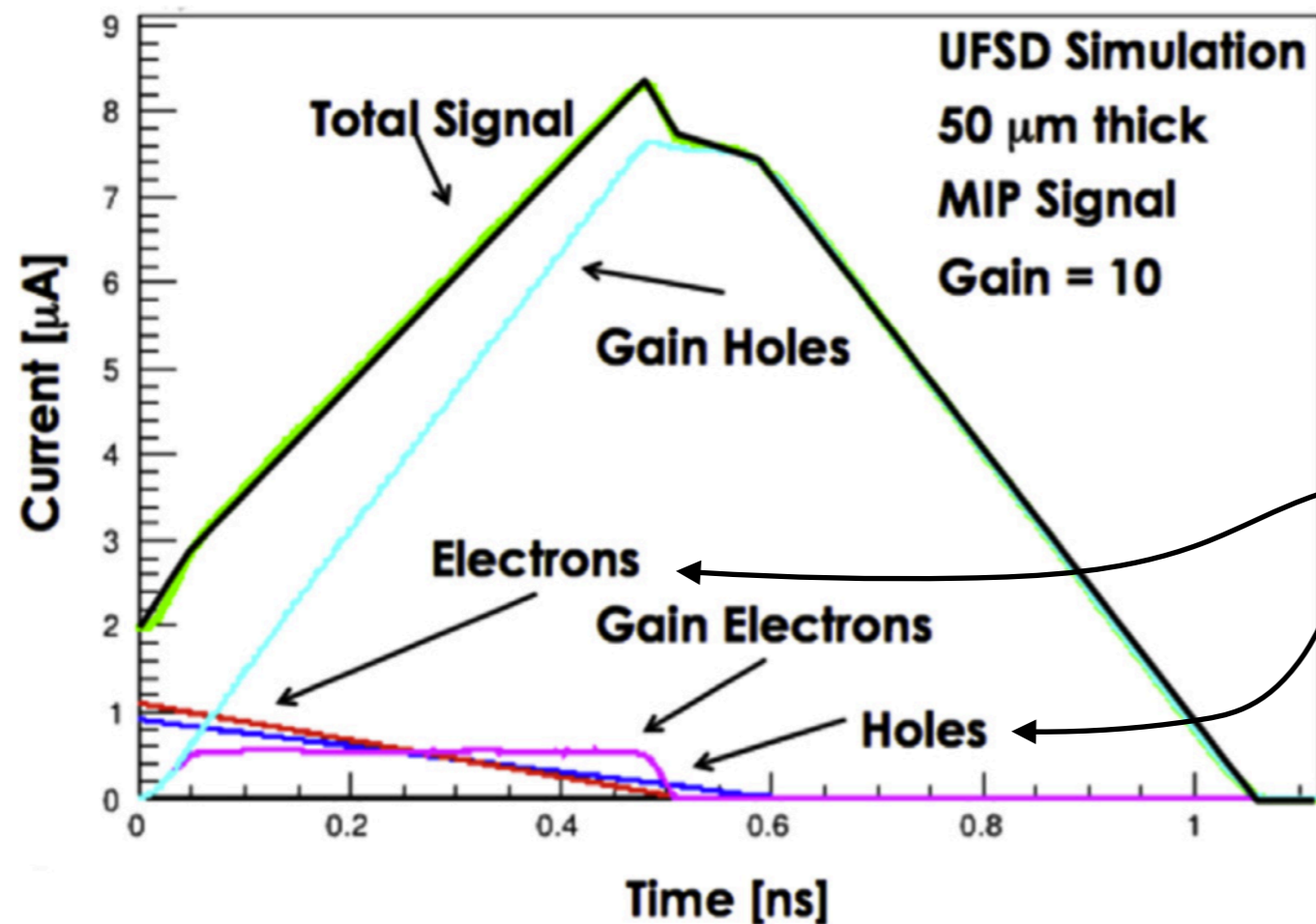

Passing charged particle deposits line-charges, as before

Primary **electrons** and primary **holes**:
triangular signal contributions,

Signals in LGADs

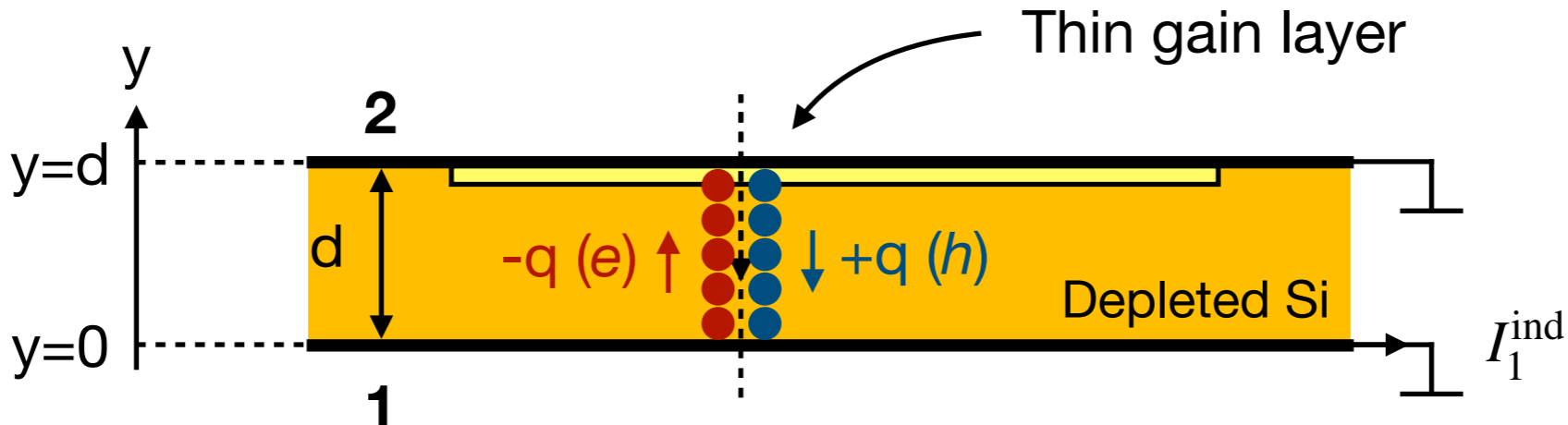

Cartiglia et al., "Design optimization of ultra-fast silicon detectors" [\[link\]](#)

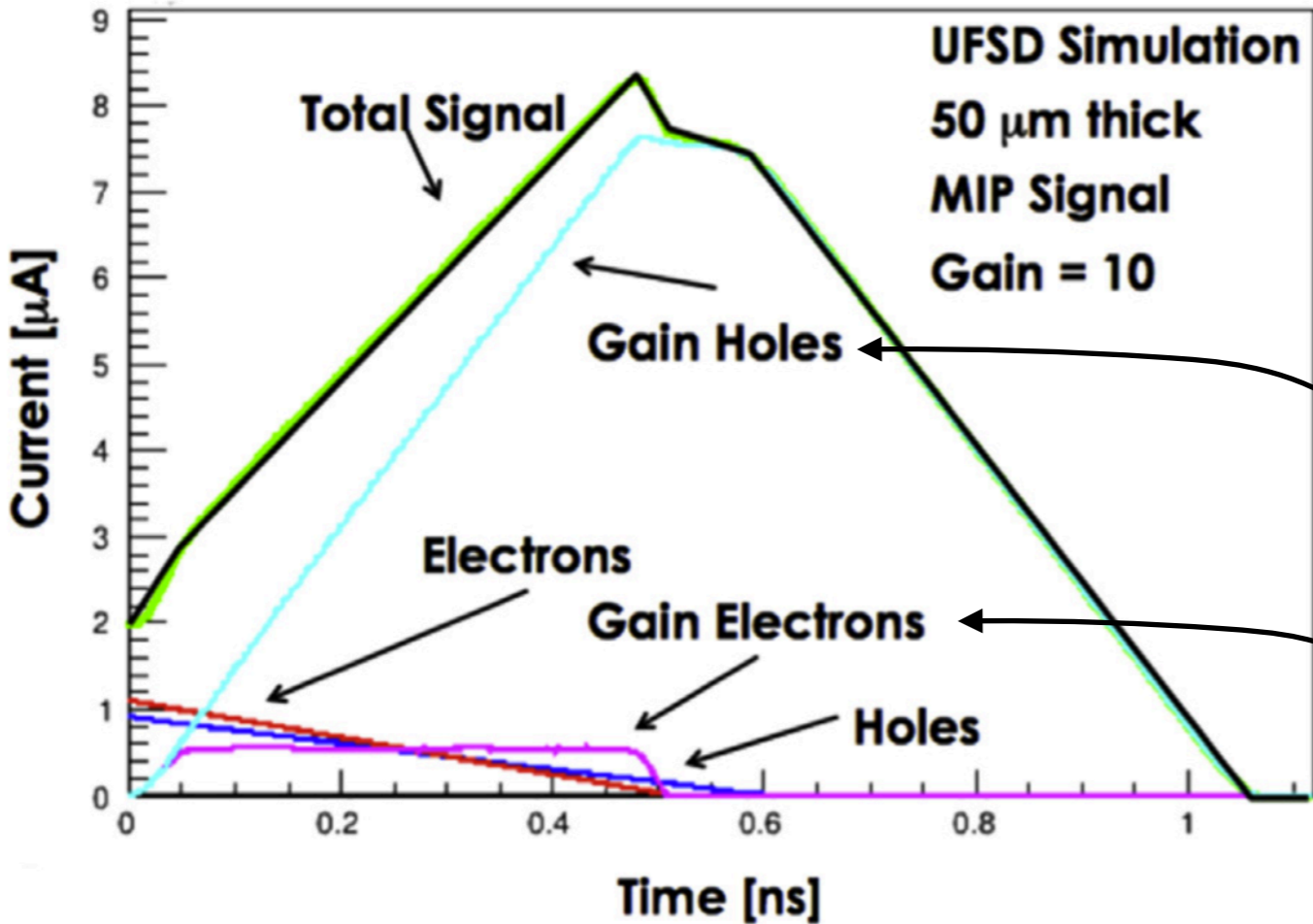

Electrons arriving at gain layer are multiplied

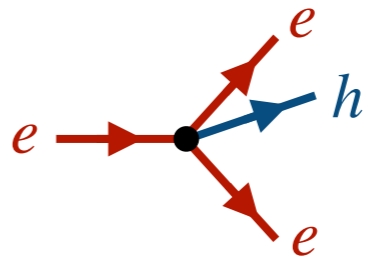

Gain holes produced at $y=d$ drift through the full detector and **dominate the total signal**

Gain electrons produced at $y=d$ are not important for total signal

The real world is not a parallel plate capacitor!

Realistic detector geometries have more complicated weighting fields ...

→ revisit the strip geometry from earlier

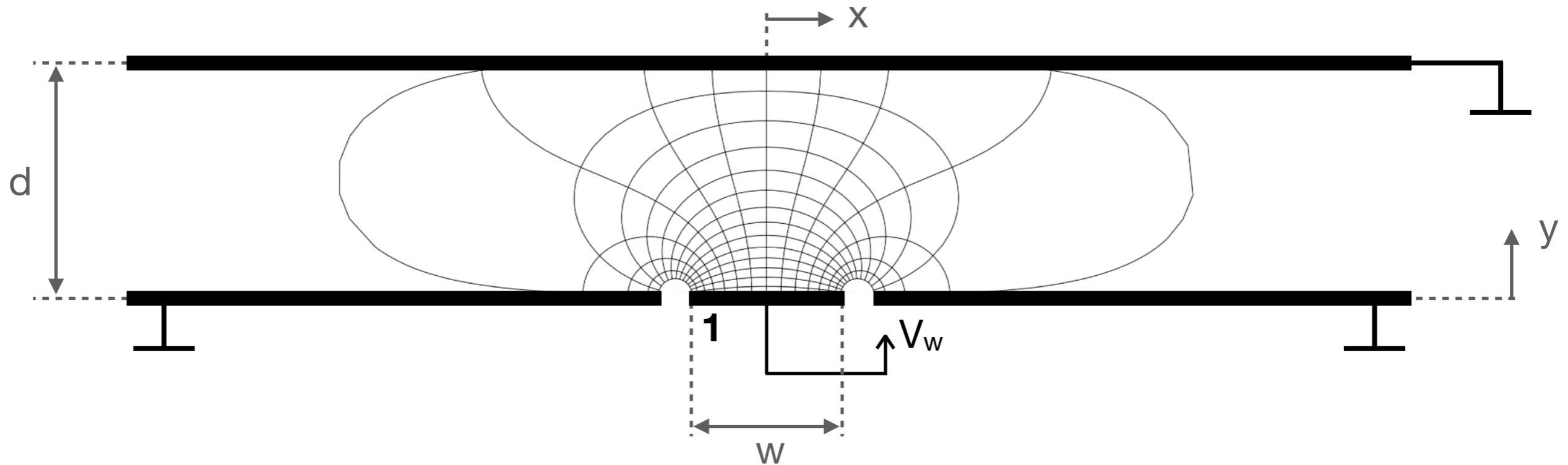

Weighting field for electrode 1:

$$E_1^y = \frac{V_w}{2d} \left[\frac{\sinh\left(\pi \frac{x+w/2}{d}\right)}{\cosh\left(\frac{x+w/2}{d}\right) - \cos\left(\frac{\pi y}{d}\right)} - \frac{\sinh\left(\pi \frac{x-w/2}{d}\right)}{\cosh\left(\frac{x-w/2}{d}\right) - \cos\left(\frac{\pi y}{d}\right)} \right]$$

Heubrandtner et al., "Static Electric Fields in an Infinite Plane Condenser with One or Three Homogeneous Layers" [\[link\]](#)

The real world is not a parallel plate capacitor!

Realistic detector geometries have more complicated weighting fields ...

→ revisit the strip geometry from earlier

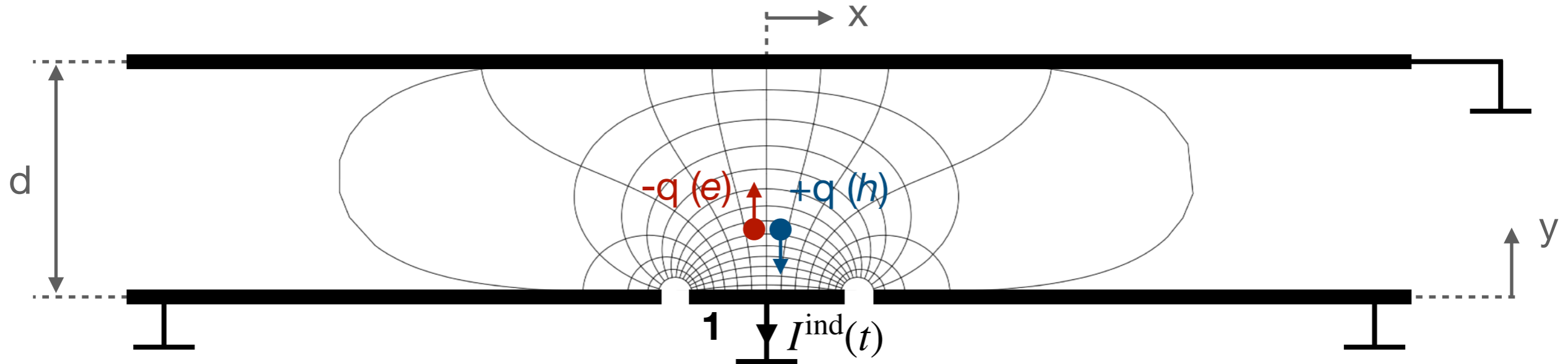

For $w \gg d$, the situation reverts to the parallel-plate geometry

For $w \sim d$, the weighting field increases towards the strip

→ signal dominated by moving charges close to the strip

... similar for weighting field for *pixel* geometry

Heubrandtner et al., “Static Electric Fields in an Infinite Plane Condenser with One or Three Homogeneous Layers” [[link](#)]

Summary

Electrical signals in detectors are exclusively due to induction by moving charged particles

Signals in silicon detectors may be computed with the Ramo-Shockley theorem (*itself a special case of a more general fact*)

$$I^{\text{ind}}(t) = -\frac{q}{V_w} \mathbf{E}_n(\mathbf{x}_q(t); V_w) \cdot \dot{\mathbf{x}}_q(t)$$

Weighting field of electrode

Particle trajectory

Depending on the **geometry** and the **charge trajectory**, either electrons or holes are responsible for the **dominant part of the signal**

Any questions? Feel free to contact me at philipp.windischhofer@cern.ch

References

W. Shockley, *Currents to Conductors Induced by a Moving Point Charge*, Journal of Applied Physics. 9 (10): 635 (1938)

S. Ramo, *Currents induced in electron motion*, PROC. IRE 27, 584 (1939)

W. Riegler, P. Windischhofer, *Signals induced on electrodes by moving charges: a general theorem for Maxwell's equations based on Lorentz-reciprocity*, Nucl. Instrum. Meth. A 980, 164471 (2020)

W. Riegler, *Signals in particle detectors*, CERN Academic Training Lectures, <https://indico.cern.ch/event/843083/>

Backup

Maxwell's equations and Lorentz reciprocity

We assume the most general form of Maxwell's equations for a linear anisotropic material of position- and frequency-dependent permittivity matrix $\hat{\epsilon}(\mathbf{x}, \omega)$, permeability matrix $\hat{\mu}(\mathbf{x}, \omega)$ and conductivity matrix $\hat{\sigma}(\mathbf{x}, \omega)$. These 3×3 matrices relate the vector fields

$$\mathbf{D} = \hat{\epsilon}\mathbf{E} \quad \mathbf{B} = \hat{\mu}\mathbf{H} \quad \mathbf{J} = \hat{\sigma}\mathbf{E} \quad (1)$$

The source of the fields is an externally impressed current density $\mathbf{J}^e(\mathbf{x}, \omega)$. In the Fourier domain, Maxwell's equations then read as

$$\nabla \cdot \hat{\epsilon}\mathbf{E} = \rho \quad \nabla \cdot \hat{\mu}\mathbf{H} = 0$$

$$\nabla \times \mathbf{E} = -i\omega\hat{\mu}\mathbf{H} \quad \nabla \times \mathbf{H} = \mathbf{J}^e + \hat{\sigma}\mathbf{E} + i\omega\hat{\epsilon}\mathbf{E}$$

$$\nabla \cdot (\mathbf{F} \times \mathbf{G}) = \mathbf{G} \cdot (\nabla \times \mathbf{F}) - \mathbf{F} \cdot (\nabla \times \mathbf{G}) \quad (4)$$

We can therefore write

$$\nabla \cdot (\mathbf{E} \times \bar{\mathbf{H}}) = \bar{\mathbf{H}}(\nabla \times \mathbf{E}) - \mathbf{E}(\nabla \times \bar{\mathbf{H}}) \quad (5)$$

$$= -\mathbf{E}\bar{\mathbf{J}}^e - i\omega\bar{\mathbf{H}}\hat{\mu}\mathbf{H} - \mathbf{E}(\hat{\sigma}^T + i\omega\hat{\epsilon}^T)\bar{\mathbf{E}} \quad (6)$$

$$\nabla \cdot (\bar{\mathbf{E}} \times \mathbf{H}) = \mathbf{H}(\nabla \times \bar{\mathbf{E}}) - \bar{\mathbf{E}}(\nabla \times \mathbf{H}) \quad (7)$$

$$= -\bar{\mathbf{E}}\mathbf{J}^e - i\omega\mathbf{H}\hat{\mu}^T\bar{\mathbf{H}} - \bar{\mathbf{E}}(\hat{\sigma} + i\omega\hat{\epsilon})\mathbf{E} \quad (8)$$

By subtracting the two expressions and using the relation $\mathbf{G}\hat{\mu}\mathbf{F} = \mathbf{F}\hat{\mu}^T\mathbf{G}$, we get

$$\nabla \cdot (\mathbf{E} \times \bar{\mathbf{H}} - \bar{\mathbf{E}} \times \mathbf{H}) = \bar{\mathbf{E}}\mathbf{J}^e - \mathbf{E}\bar{\mathbf{J}}^e \quad (9)$$

Integrating over a volume V enclosed by surface A and applying Gauss' theorem we have

$$\oint_A (\mathbf{E} \times \bar{\mathbf{H}} - \bar{\mathbf{E}} \times \mathbf{H})d\mathbf{A} = \int_V (\bar{\mathbf{E}}\mathbf{J}^e - \mathbf{E}\bar{\mathbf{J}}^e)dV \quad (10)$$

Drift velocities in silicon

