

UK Advanced Instrumentation Training

Circuit Design 3 & 4
Simulation LTspice 1 & 2

Dr Weida Zhang
@physics.ox.ac.uk
2022 May 10



Circuit Design, Noise, Grounding

- Workflow
- Simulation
- Analyze -> Block Diagram, Specs
- Schematic -> Circuit topology, Constraints
- Layout -> GERBER, BOM, Assembly-files
- Manufacturing (fabrication, population, assembly)
- Debug, Characterization -> Reports
- (Revision)

Circuit Design, Noise, Grounding

- Workflow
 - Analyze -> Block Diagram, Specs

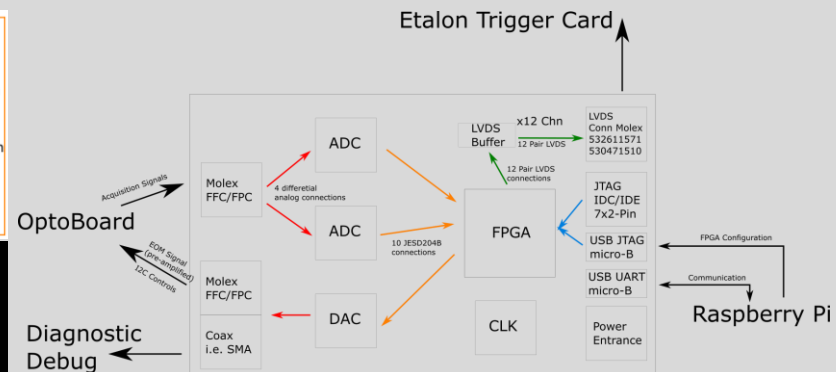
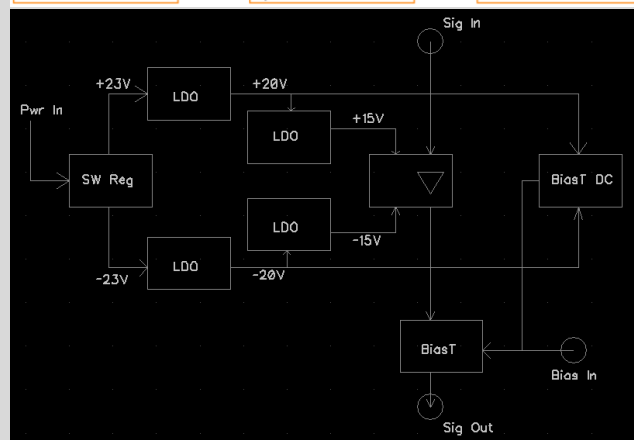
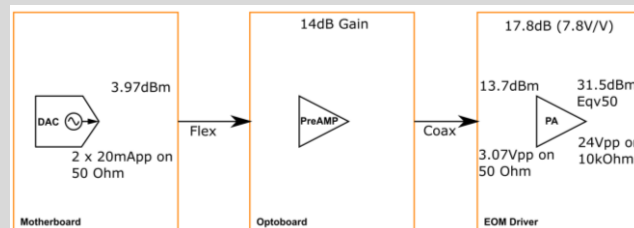

Recalculated Power Consumption at 3.8.9.2:

	Layer	Power Supply Net Name	Voltage (V)	Consumer	Current Input (mA)
ADP2384	1	VDD3V8	3.8	DAC + CLK	454
				Total	454
MAX15301	1	VDD3V3	3.3	LVDS + USB	155
				FPGA Fabric	TBD (Max725)
				DAC + CLK	5.7
				ADC	801
				Total	1686.7
MAX15301	1	VDD1V8	1.8	DAC + CLK	767
				2 ADCs	1572
				FPGA MGT	2983
				FPGA Fabric	2938
				Total	8260
MAX15301	1	VCCINT	0.95	FPGA Fabric	10262
				Total	10262

Circuit Design, Noise, Grounding

- Workflow
 - Schematic -> Circuit topology, Constraints

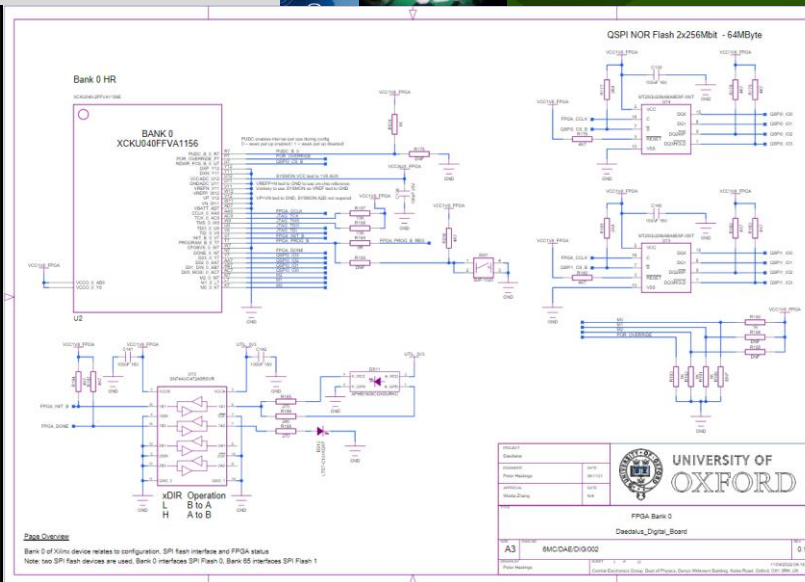
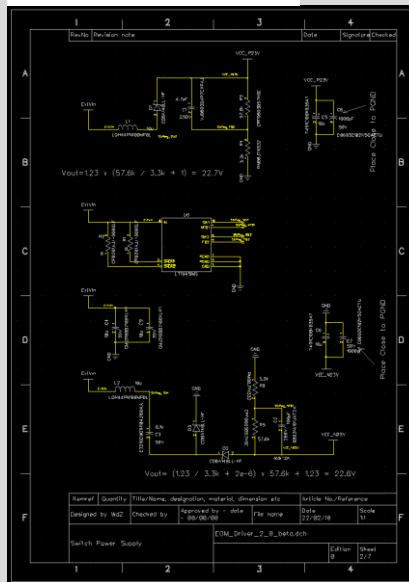
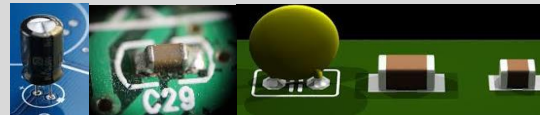
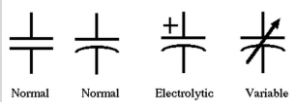

Circuit Design, Noise, Grounding

- Workflow
 - Layout -> GERBER, BOM, Assembly-files

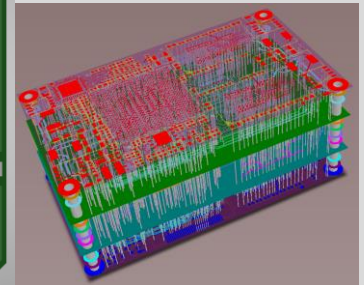
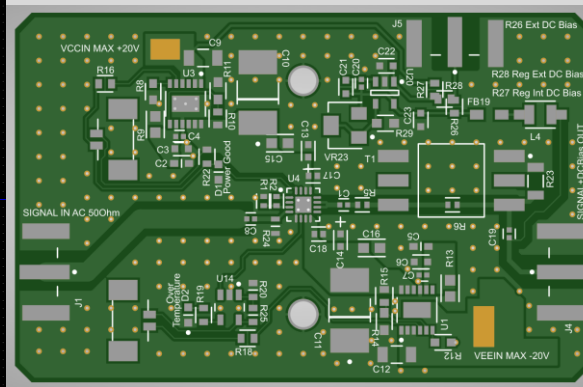
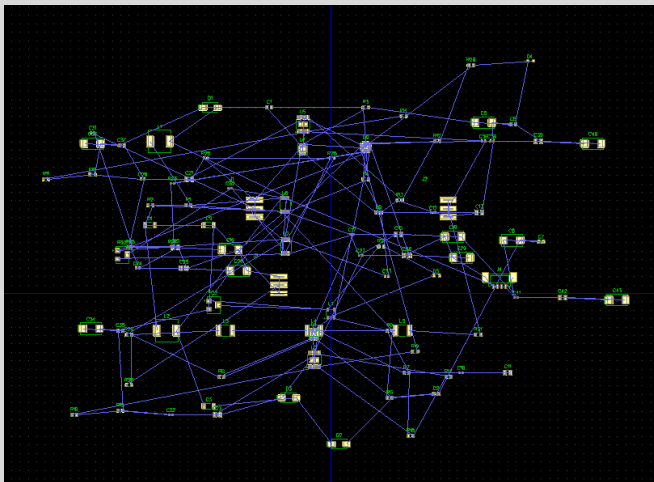

Circuit Design, Noise, Grounding

- Workflow
 - Manufacturing (fabrication, population, assembly)

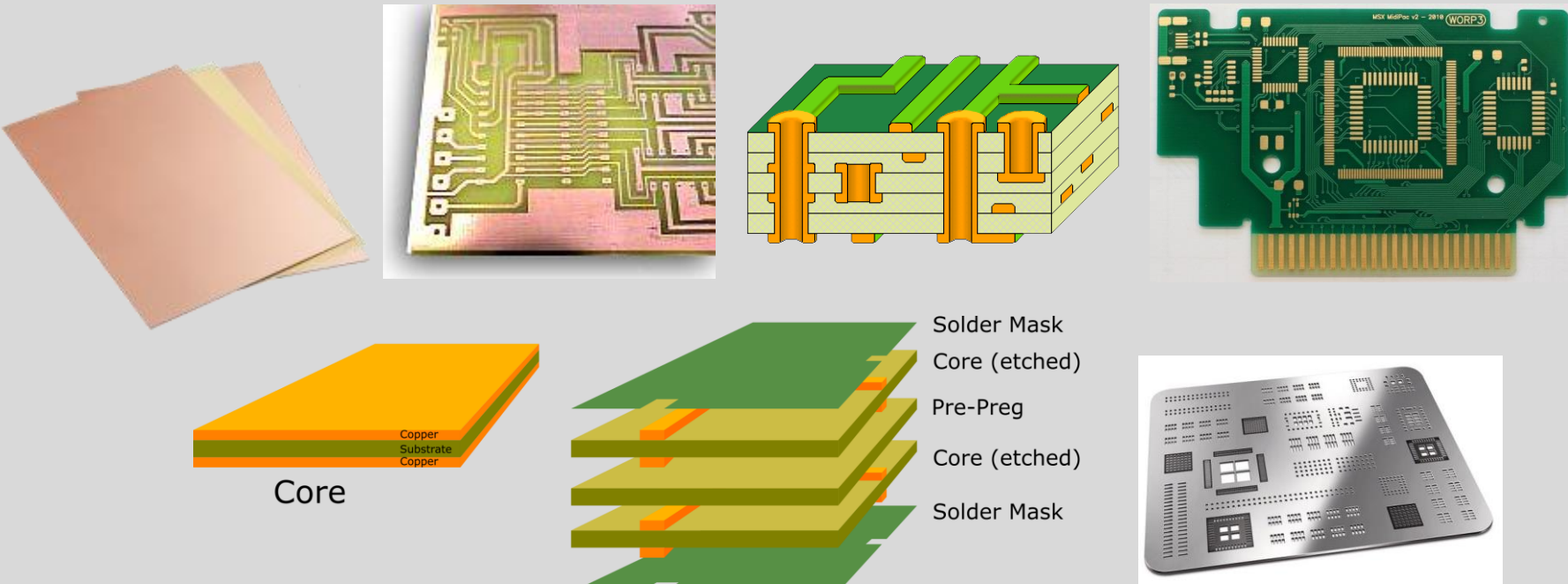

Circuit Design, Noise, Grounding

- Noise

- Thermal \sim quasi-white, Gaussian, $4kTR$; Conductor
- Shot \sim white, Gaussian, $2e|I|$; Semiconductor
- $1/f$, flicker $\sim f$ -depend; Anything
- Burst ~ 2 -value, f -depend; Semiconductor

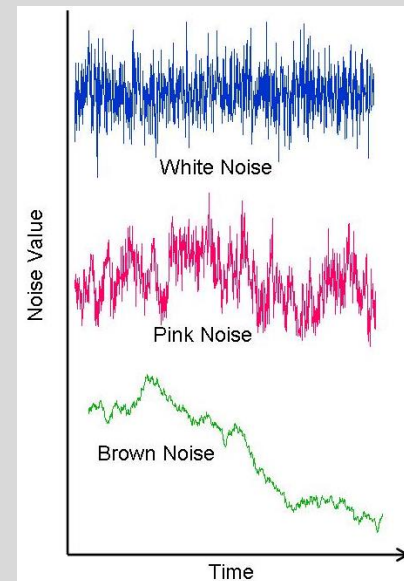
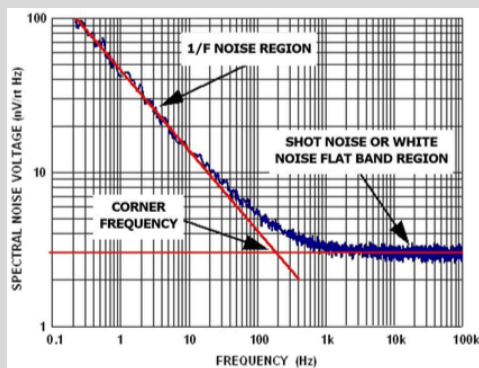

Circuit Design, Noise, Grounding

- Interference/Crosstalk
 - Data/Clock dependent \sim non-stationary, f -depend
- Systematic
 - Harmonics, Spurs $\sim f$ -depend; Amp-linearity, ADC, DAC
 - Quantization Noise \sim quasi-white, uniform; ADC
 - Aliasing/Mirror Noise \sim Signal x Sinc, uniform; ADC, DAC
 - Clock Phase Noise $\sim 1/f^\alpha$; resonant, quartz, PLL

Circuit Design, Noise, Grounding

Harmonics

Spurs/Crosstalk

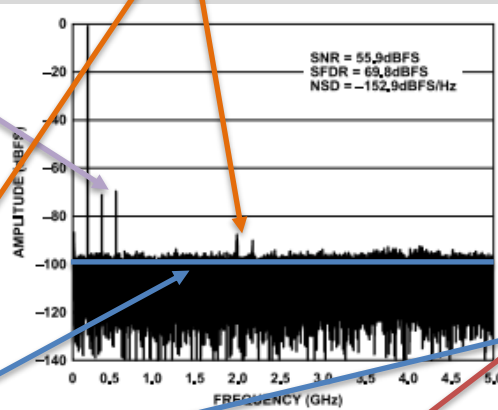
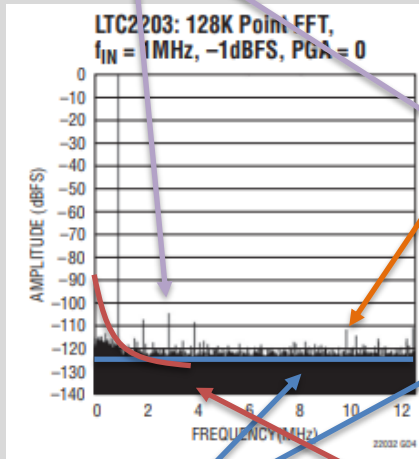

Figure 3. Single-Tone FFT with $f_{IN} = 170\text{ MHz}$, 10 GSPS

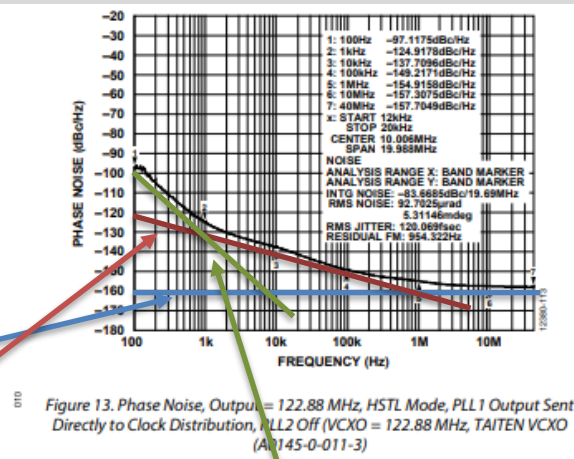

Figure 13. Phase Noise, Output = 122.88 MHz, HSTL Mode, PLL1 Output Sent Directly to Clock Distribution, PLL2 Off (VCXO = 122.88 MHz, TAITEN VCXO (A1145-0-011-3))

Thermal + Shot + Quantization

$1/f + (\text{Burst})$

$1/f^\alpha$

Circuit Design, Noise, Grounding

- Noise

- Units PSD vs PSD

$$\bar{P} = \lim_{T \rightarrow \infty} \frac{1}{T} \int_{-T/2}^{T/2} \frac{x^2(t)}{R} dt$$

x is the random variable of noise, with the unit of voltage
 Resistivity R is sometimes ignored to 1, \bar{P} is average power

$$\bar{P} = \int_0^B S_x(f) df$$

B is the bandwidth, S_x is the power spectrum density,
 with the unit of Power per Bandwidth, i.e. dBm/Hz

$$x_{\text{RMS}} = \sqrt{\bar{P}R}$$

x_{RMS} is the root-mean-square of the noise, with the unit
 of voltage

$$v_n(f) = \sqrt{S_x(f)R} = \sqrt{\frac{\bar{x}^2}{RB}}$$

This is only in white noise, $v_n(f)$ is the voltage
 spectrum density, with the unit of $V/\sqrt{\text{Hz}}$

Circuit Design, Noise, Grounding

- Noise

- Conversion

- $0\text{dBm} = 0.632V_{\text{PP}} = 0.233 V_{\text{RMS}}$

- Quantify and Comparison

$$x_{\text{RMS}} = \sqrt{\bar{P}R}$$

$$v_n(f) = \sqrt{S_x(f)R} = \sqrt{\frac{\bar{x}^2}{RB}}$$

ADA4099-1/ADA4099-2

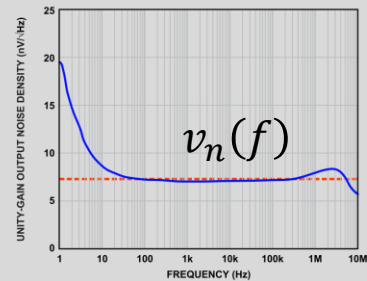

Figure 42. Unity-Gain Output Noise Density vs. Frequency

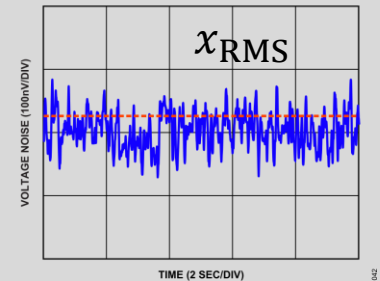

Figure 43. 0.1 Hz to 10 Hz Noise

analog.com

- v_n as a number gives floor
- x_{RMS} at low frequency tells flicker

NOISE PERFORMANCE				
Input Voltage Noise	f = 0.1 Hz to 10 Hz	150	150	nV p-p
	1/f noise corner	6	6	Hz
Over-The-Top	f = 100 Hz	7	7	nV/√Hz
	f = 100 Hz, $V_{\text{CM}} > +V_S$	8	8	nV/√Hz
Input Current Noise	f = 100 Hz	0.5	0.5	pA/√Hz
	Over-The-Top	f = 100 Hz, $V_{\text{CM}} > +V_S$	5	5

Circuit Design, Noise, Grounding

- Noise
 - Paths
 - Signal Input
 - Resistive Components
 - Semiconductor Devices
 - Non-Linear (not LTI)
 - Power Supplies
 - Indirect Coupling

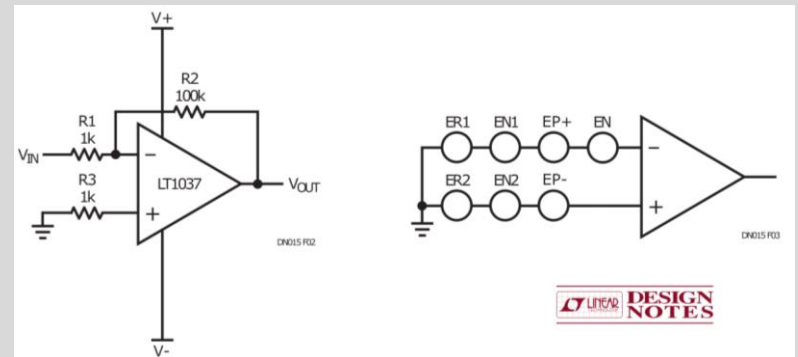

Circuit Design, Noise, Grounding

- Noise

- Paths

- Signal Input

- Antenna, transducer

-> matching network

- Previous Stage of Amps

-> termination

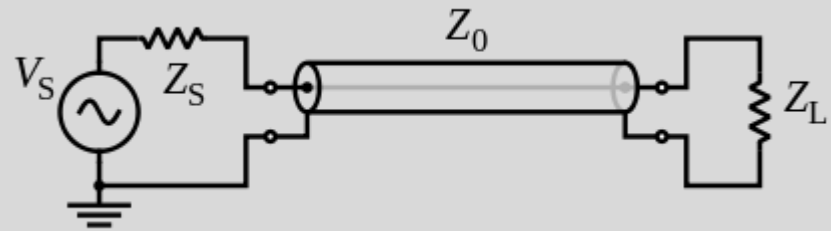

Source: Texas Instruments

$$F_n = F_1 + \frac{F_2 - 1}{G_1} + \frac{F_3 - 1}{G_1 G_2} + \dots$$

Circuit Design, Noise, Grounding

- Noise
 - Paths
 - Signal Input
 - ADC
 - Quantization ENOB
 - Aliasing

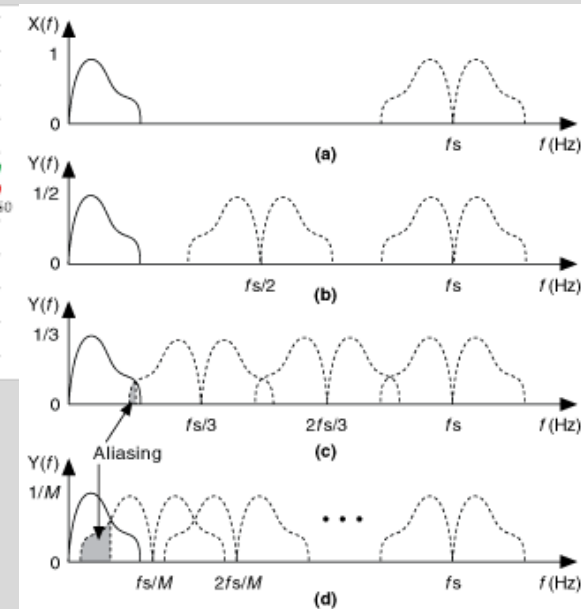
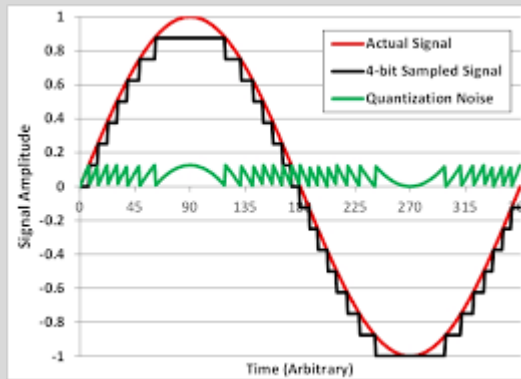

$$x[n] = \sum_n \int s(t) \delta(t - nT_S) dt$$

Circuit Design, Noise, Grounding

- Noise
 - Paths
 - Signal Input
 - DAC
 - Quantization ENOB
 - Mirror/Image

$$s(t) = \sum_n x[n] * \text{rect}\left(\frac{t}{T_S}\right)$$

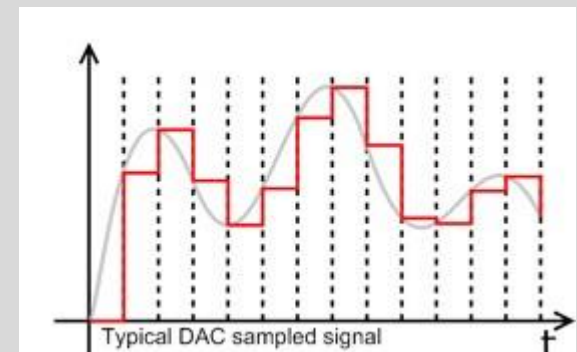
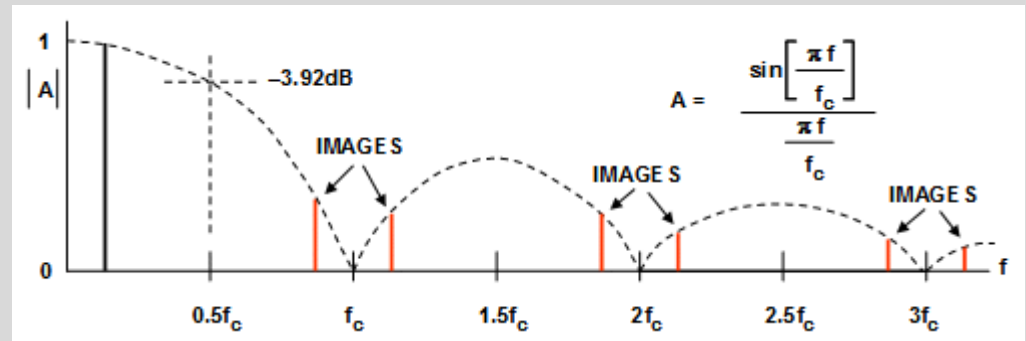

Circuit Design, Noise, Grounding

- Noise
 - Paths
 - Resistive Components
 - Semiconductor Devices

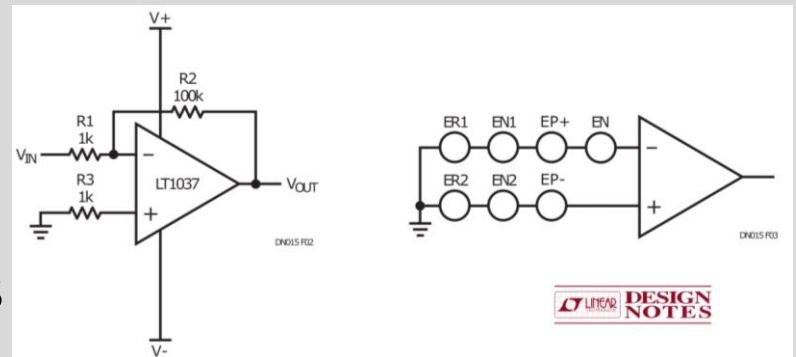

Circuit Design, Noise, Grounding

- Noise
 - Paths
 - Non-Linear (not LTI)

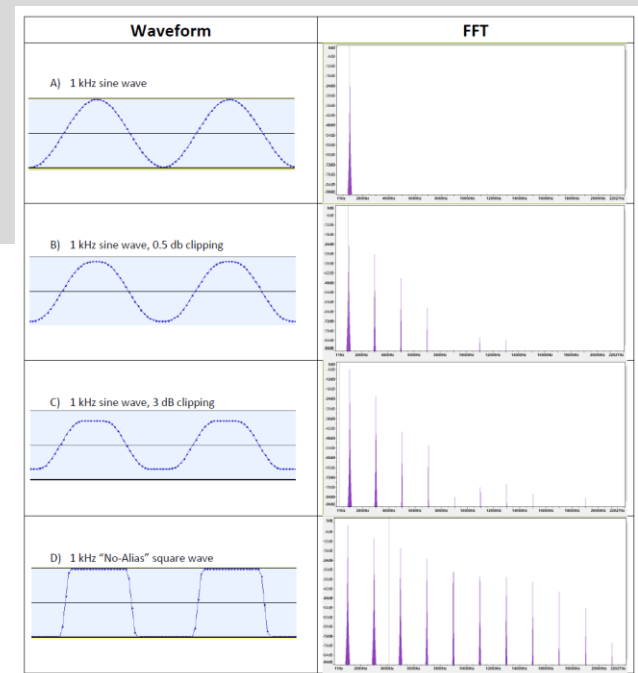
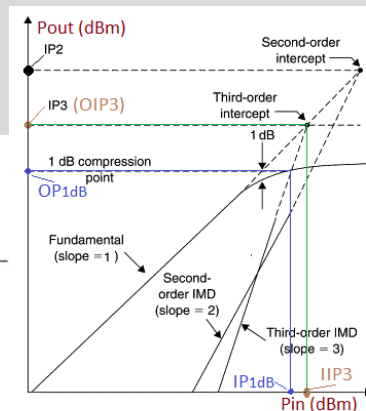
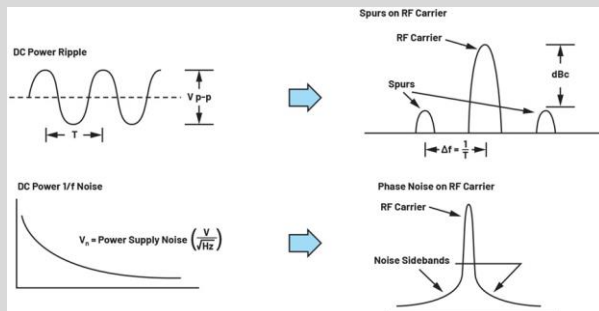

Circuit Design, Noise, Grounding

- Noise
 - Paths
 - Power Supplies
 - Indirect Coupling
 - Power integrity

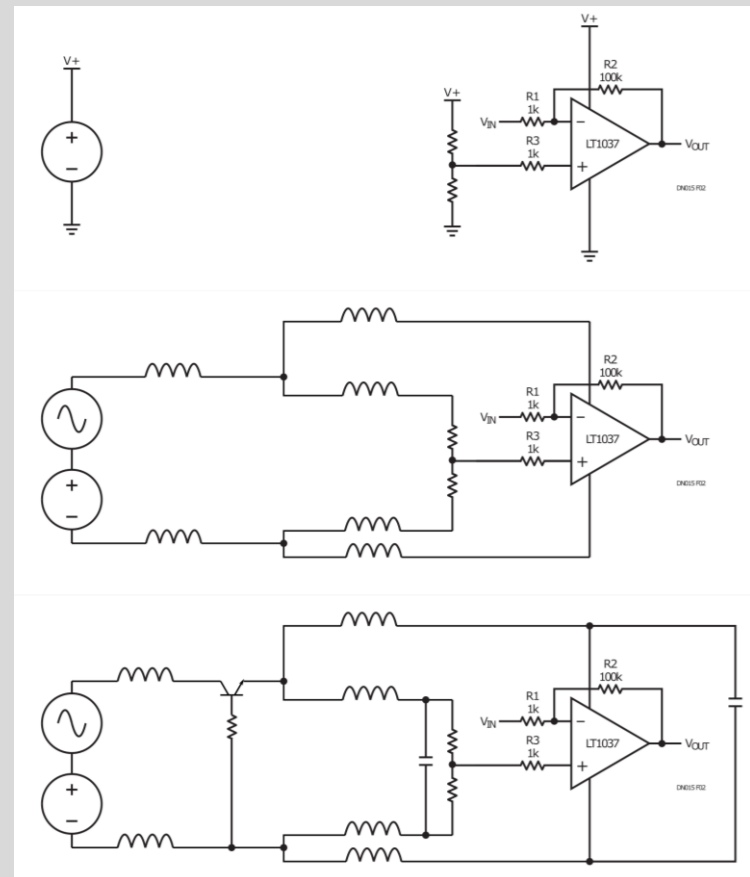

Circuit Design, Noise, Grounding

- Noise
 - Paths
 - Power Supplies
 - Indirect Coupling

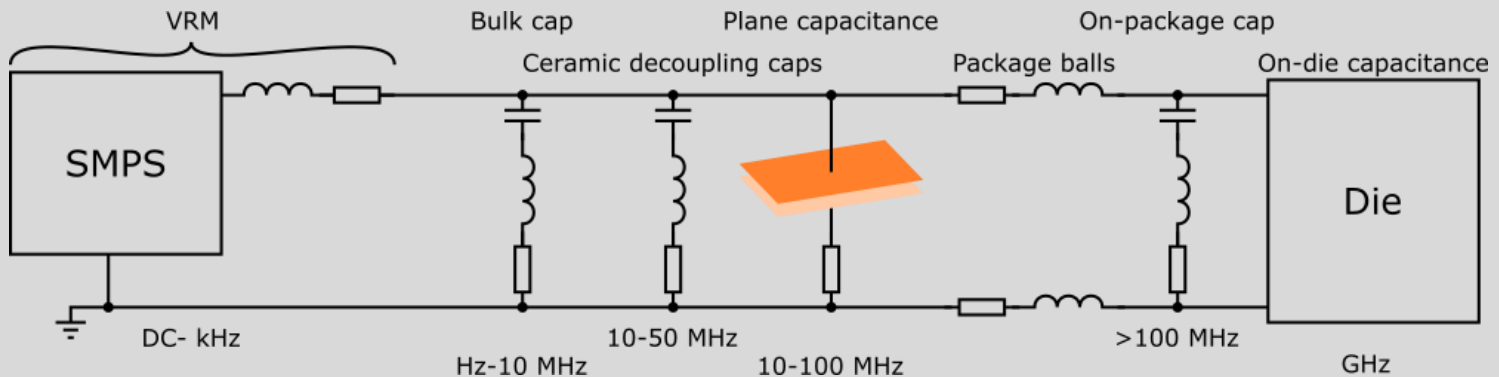
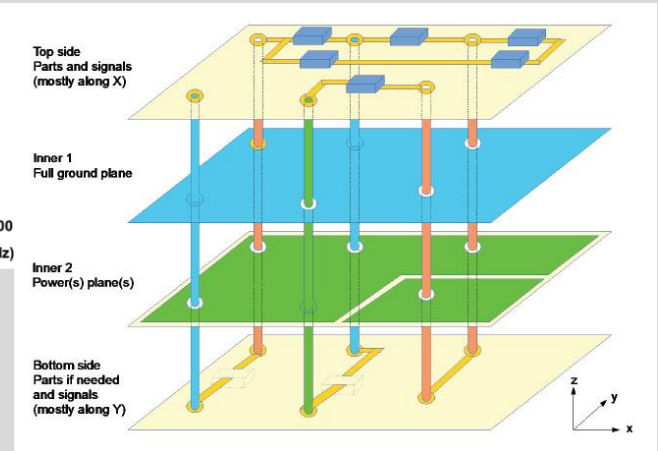
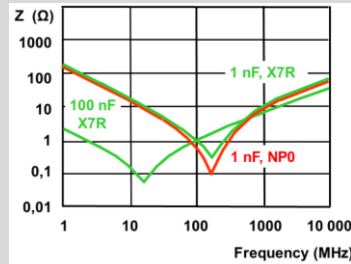

Circuit Design, Noise, Grounding

- Grounding

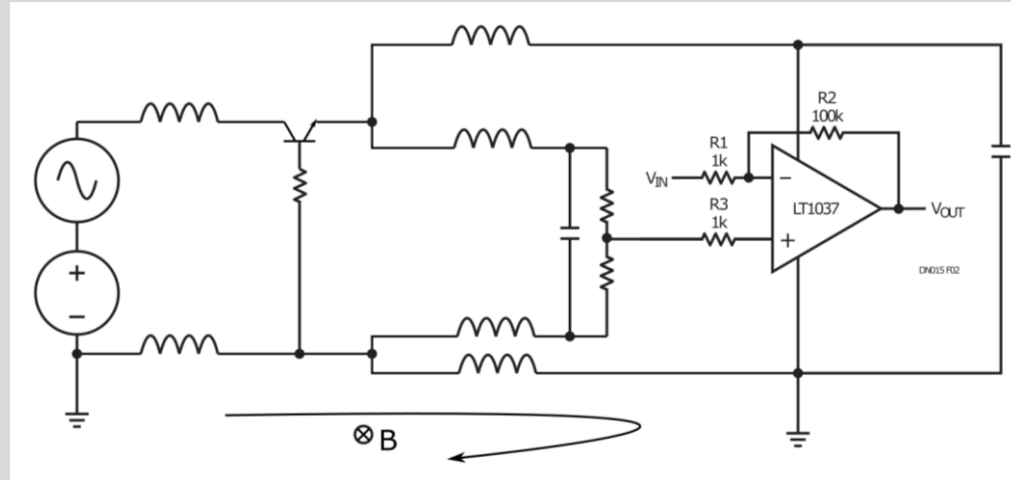

Circuit Design, Noise, Grounding

- Circuit Design SW Packages



- OrCAD/Allegro



ALTIUM
DESIGNER

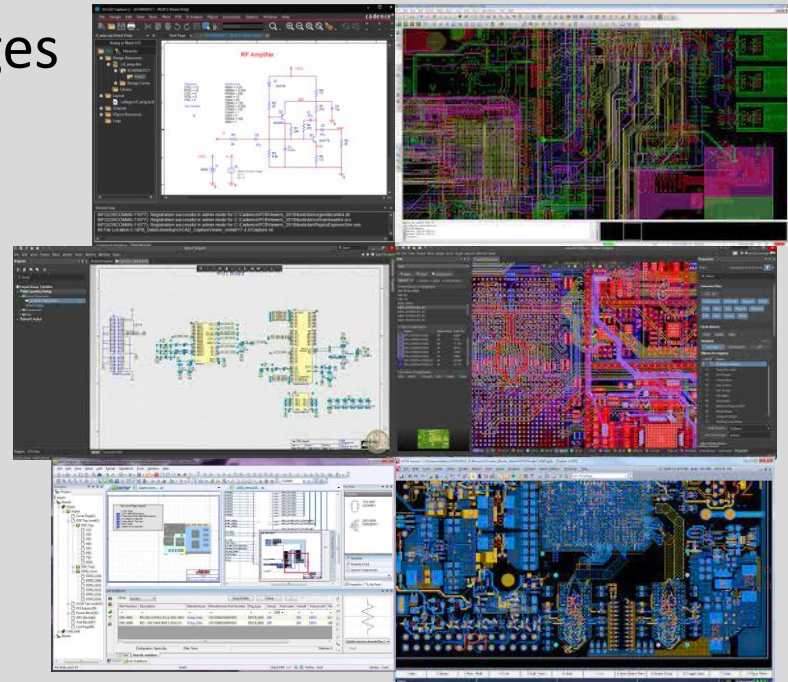

- 30th May 1500 & 2nd Jun 1100 by Dr Daniel Weatherill

Circuit Design, Amplifier, Clock

- Transmission Line Theory

$$v(z,t) = L\Delta z \frac{\partial i(z,t)}{\partial t} + v(z + \Delta z, t)$$

$$i(z,t) = C\Delta z \frac{\partial v(z + \Delta z, t)}{\partial t} + i(z + \Delta z, t)$$

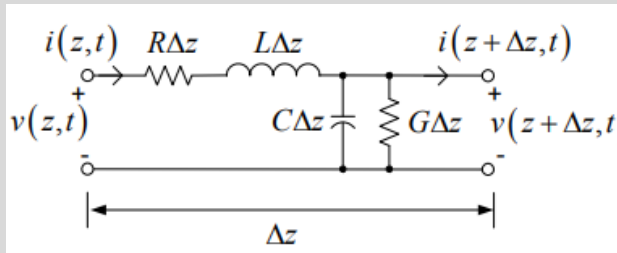

$$\frac{\partial v(z,t)}{\partial z} = -L \frac{\partial i(z,t)}{\partial t}$$

$$\frac{\partial i(z,t)}{\partial z} = -C \frac{\partial v(z,t)}{\partial t}$$

$$\frac{\partial^2 V}{\partial t^2} - u^2 \frac{\partial^2 V}{\partial x^2} = 0$$

$$\frac{\partial^2 I}{\partial t^2} - u^2 \frac{\partial^2 I}{\partial x^2} = 0$$

$$u = \frac{1}{\sqrt{LC}}$$

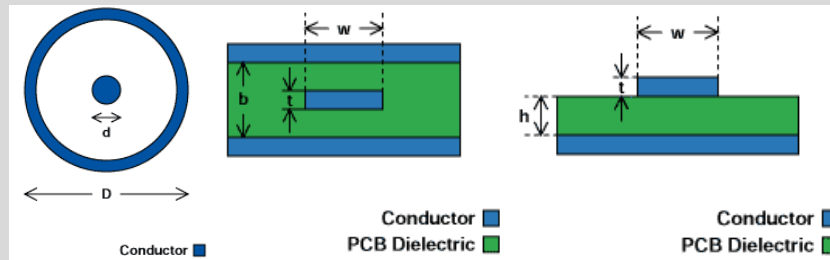

$$V(x) = V_1 e^{-jkx} + V_2 e^{+jkx}$$

$$I(x) = \frac{V_1}{Z_0} e^{-jkx} - \frac{V_2}{Z_0} e^{+jkx}$$

$$Z_0 = \sqrt{\frac{L}{C}}$$

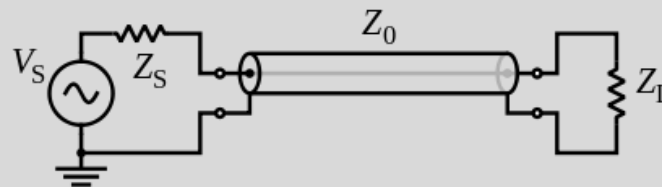

Circuit Design, Amplifier, Clock

- Signal Integrity
 - Designing and Maintaining Trace Structure
 - Termination

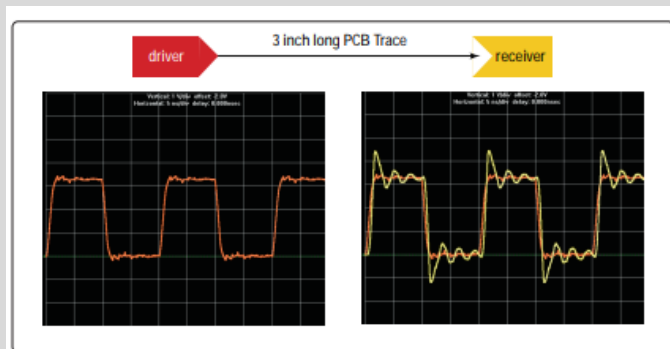
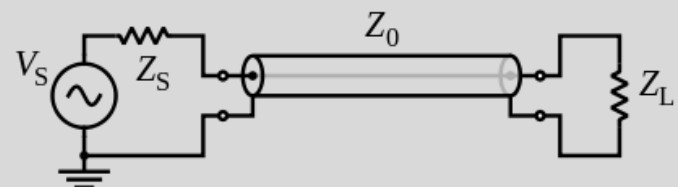
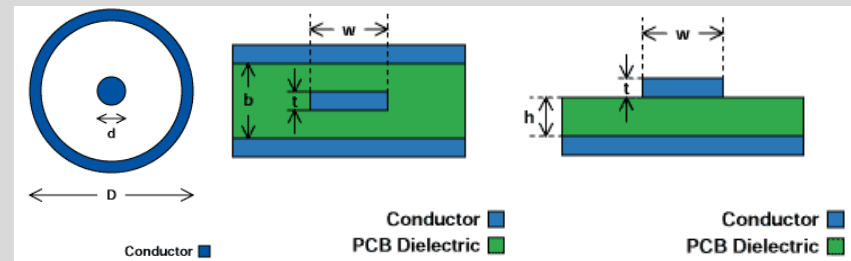

Figure 1. A signal as it emerges from the driver chip (left) is distorted by multiple reflections from impedance discontinuities at both ends (right).

Source: Keysight



Circuit Design, Amplifier, Clock

- Scattering Parameter (S-Parameter)



$$\begin{pmatrix} b_1 \\ b_2 \end{pmatrix} = \begin{pmatrix} S_{11} & S_{12} \\ S_{21} & S_{22} \end{pmatrix} \begin{pmatrix} a_1 \\ a_2 \end{pmatrix}$$

S_{11} is the input port voltage reflection coefficient
 S_{12} is the reverse voltage gain
 S_{21} is the forward voltage gain
 S_{22} is the output port voltage reflection coefficient.

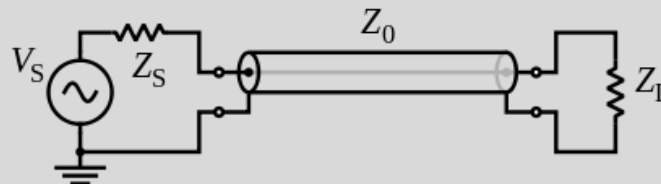

Circuit Design, Amplifier, Clock

- Scattering Parameter (S-Parameter)

CMA-81+
SMT Gain Block, DC - 6000 MHz, 500



Generic photo used for illustration purposes only

- Ceramic, hermetically sealed nitrogen filled
- Low profile case, 0.045
- High IP3, +38 dBm



HMC1049LP5E

Overview | Evaluation Kits | Documentation | Tools & Simulations | Reference Materials | Design Resources

View All Data Sheets (2)

Data Sheet Rev. 8

S-Parameters

Mini-Circuits Laboratory

Date: 11/3/2015 at 1:45:13 PM

IS2P DATA File Format

IType: MMIC Amplifier

Model: CMA-81+

IS/Unit: 1

IFixture: TB-829-81+ NO PORT EXTENSION.

IPIN OUT: PORT 1 - PIN 2, PORT 2 - PIN 7, GROUND - 1,3,4,5,6,8,Bottom Center Paddle

ITEST CONDITIONS: Temp= +85 (Deg C) RF Power= +25.00 (dBm) V limit=5(V) I limit=250(mA) Z=50 OHM

INAWFER/LOT#: n/a DATE CODE: 1448

INetwork Analyzer: PNA-X N5242A S/N 71484 CAL DUE: 12/11/2015

IP_Supply/Multimeter: HP E3632A S/N 63249 CAL DUE: 12/11/2015

!

#	Hz	S	dB	R	50				
14	f(Frequency)	S11 dB	S11 Deg	S21 dB	S21 Deg	S12 dB	S12 Deg	S22 dB	S22 Deg
15	10000000	-44.3357200	-166.7859000	10.5643500	179.1727000	-20.4733800	-0.4232950	-20.3147700	0.1972064
16	15000000	-38.1764500	-83.7452500	10.5889700	179.9357000	-20.4535600	-0.2922311	-19.5530300	-5.7504110
17	20000000	-42.6544600	167.7492000	10.5664400	178.6488000	-20.4699600	-0.9079536	-20.3498200	-0.6635373
18	25000000	-39.2277800	159.5075000	10.5462600	178.8562000	-20.50839200	-1.2963140	-20.7143700	0.4261140
19	30000000	-43.5065400	178.5663000	10.5655900	177.9172000	-20.4823700	-1.2938770	-20.4270900	-1.7578030
20	35000000	-45.7234300	-162.4352000	10.5566000	177.6096000	-20.5957600	-1.3303600	-20.3532100	-2.6354570
21	40000000	-42.7495200	-168.8238000	10.5670200	177.2186000	-20.4884000	-1.6336710	-20.4072700	-2.9222600
22	45000000	-41.7412000	-172.4569000	10.5645000	176.8549000	-20.4867100	-1.8795270	-20.5594500	-3.3060280
23	50000000	-41.7112100	-172.0631000	10.5706900	176.5308000	-20.4854800	-2.0976540	-20.5895600	-3.8508110
24	55000000	-40.9887200	-171.4034000	10.5617000	176.2349000	-20.4676900	-2.6154540	-20.5889600	-5.0186350
25	60000000	-40.5970600	-173.2739000	10.5600300	175.9174000	-20.4700600	-2.8611950	-20.6548000	-5.5687010
26	65000000	-40.4775000	-173.6170000	10.5591500	175.5924000	-20.4693900	-3.0714600	-20.7066200	-5.9090000
27	70000000	-39.8875100	-168.1615000	10.5574100	175.2423000	-20.4658900	-3.3031110	-20.7705300	-6.6780670
28	75000000	-39.6015700	-166.5091000	10.5573000	174.9256000	-20.4715600	-3.5408440	-20.8229700	-7.4156110

Circuit Design, Amplifier, Clock

- Matching Network

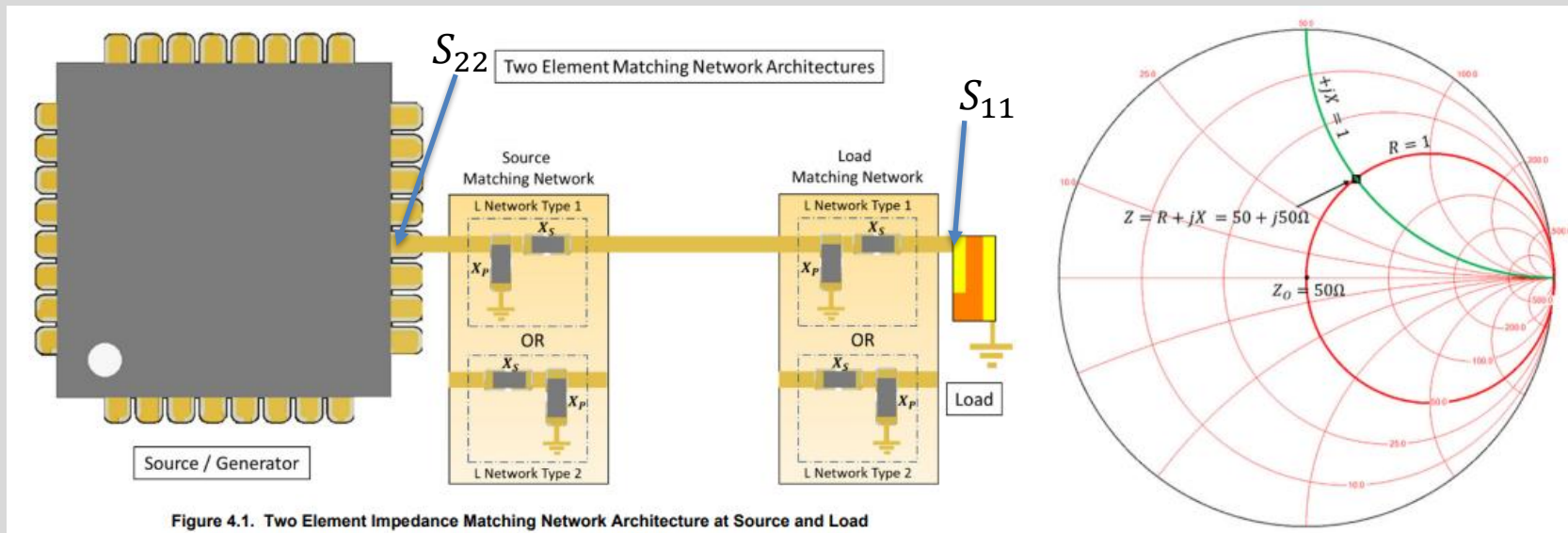

Source: SiLabs

Circuit Design, Amplifier, Clock

- Simulation of Amplifier Design

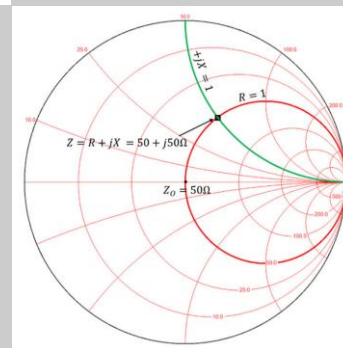
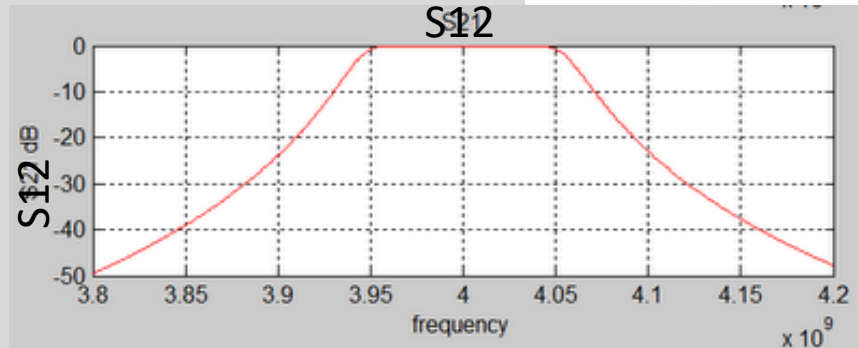
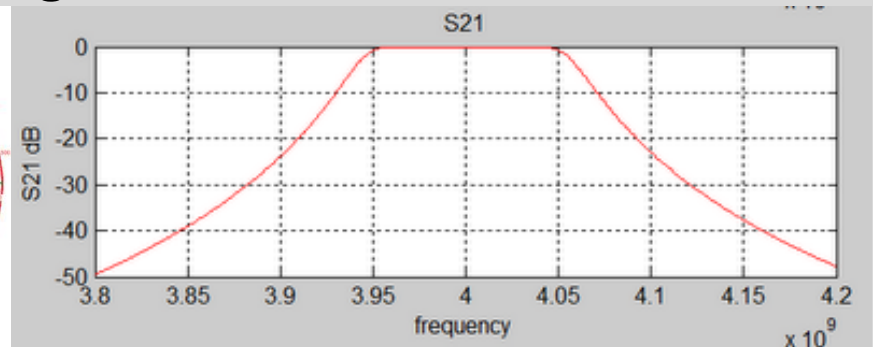
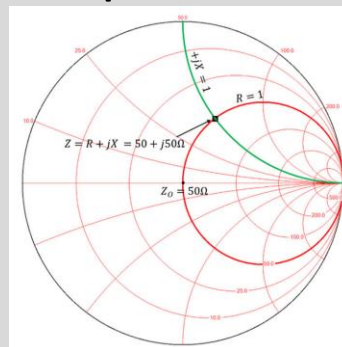

Circuit Design, Amplifier, Clock

- Clock Jitter/Phase noise in Digital System/Comms

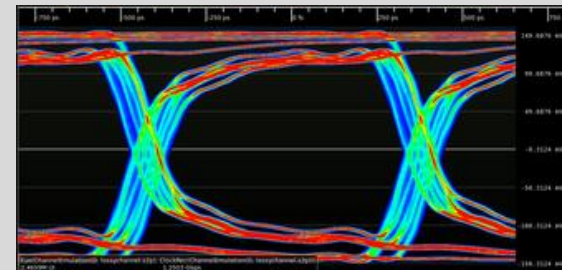
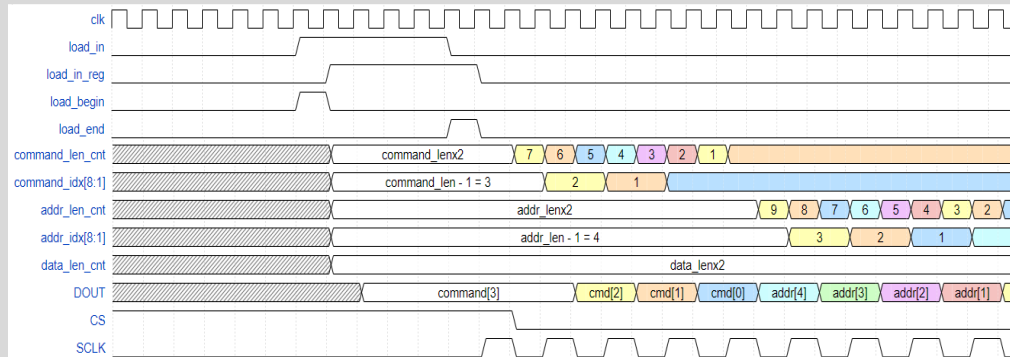

Circuit Design, Amplifier, Clock

- Clock Jitter/Phase noise in DAQ

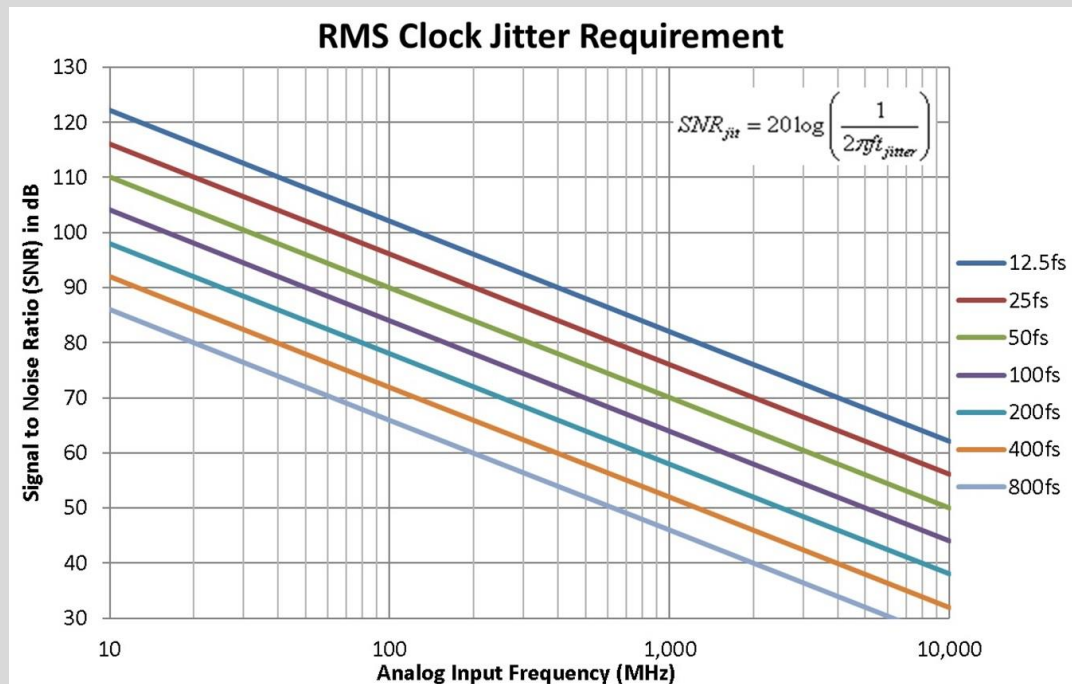

Circuit Design, Amplifier, Clock

- Clock Jitter/Phase noise

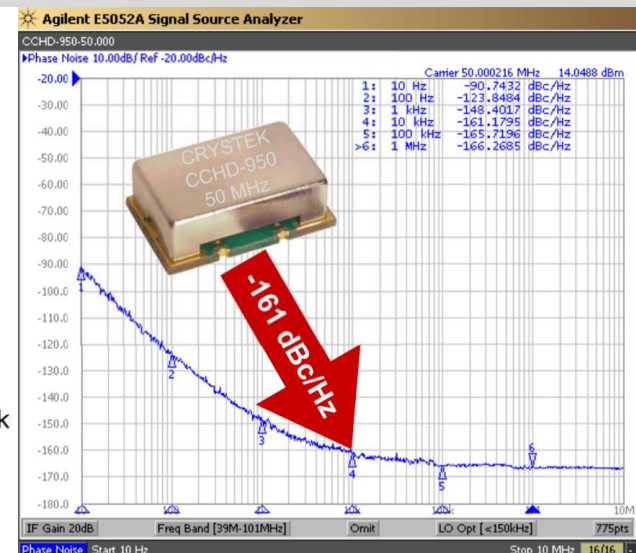
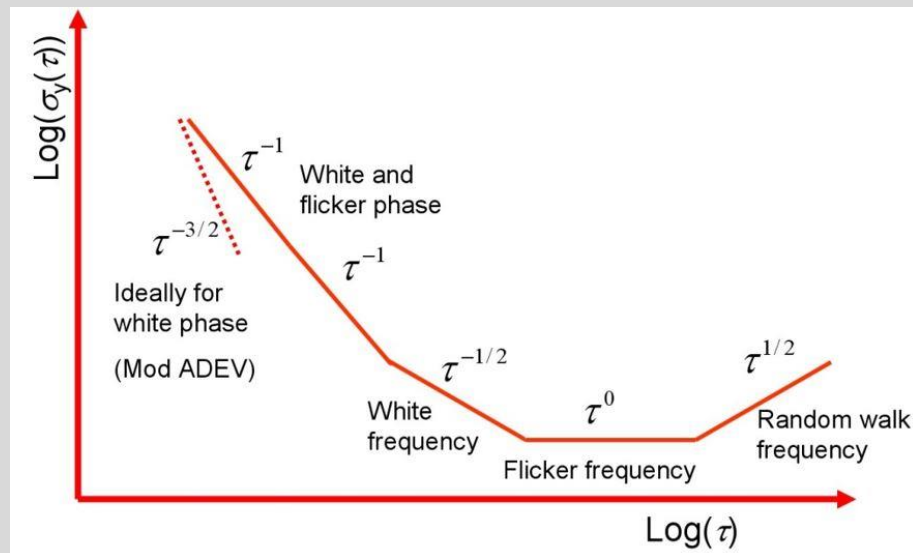

Source: NIST

Circuit Design, Amplifier, Clock

- Phase Locked Loop

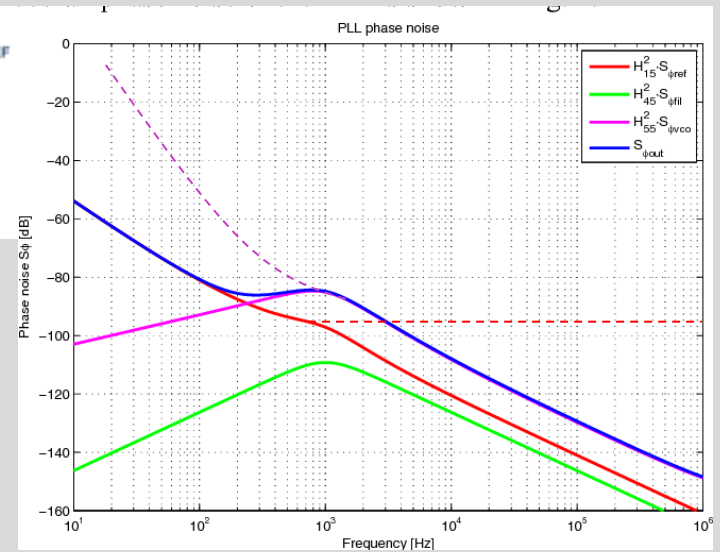
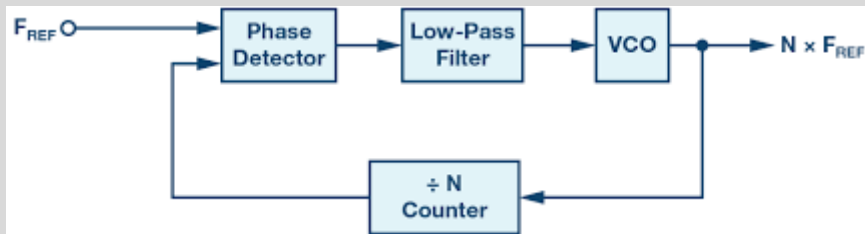

Circuit Design, Amplifier, Clock

• How to read datasheet

HMC1049LP5E

FEATURES

- Low noise figure: 1.8 dB
- P1dB output power: 14.5 dBm
- P_{SAT} output power: 17.5 dBm
- High gain: 15 dB
- Output IP3: 29 dBm
- Supply voltage: $V_{DD} = 7$ V at 70 mA
- 50 Ω matched input/output (I/O)
- 32-lead, 5 mm x 5 mm LFCSP package: 25 mm²

APPLICATIONS

- Test instrumentation
- High linearity microwave radios
- VSAT and SATCOM
- Military and space

GENERAL DESCRIPTION

The HMC1049LP5E is a GaAs MMIC low noise amplifier (LNA) that operates between 0.3 GHz and 20 GHz. This LNA provides 15 dB of small signal gain, 1.8 dB noise figure, and an IP3 output of 29 dBm, yet requires only 70 mA from a 7 V supply. The P1dB output power of 14.5 dBm enables the LNA to function as a local oscillator (LO) driver for balanced, I/Q, or image rejection mixers. V_{DD} can also be applied to Pin 21, although Pin 21 requires a bias tee with $V_{DD} = 4$ V. The HMC1049LP5E amplifier I/Os are internally matched to 50 Ω , and the device is supplied in a compact, leadless 5 mm x 5 mm LFCSP package.

Figure 1.

HMC1049LP5E

SPECIFICATIONS

$T_A = 25^\circ\text{C}$, $V_{DD} = 7$ V, $I_{DD} = 70$ mA¹.

Table 1.

Parameter	Min	Typ	Max	Min	Typ	Max	Min	Typ	Max	Unit
FREQUENCY RANGE	0.3			1			14		20	GHz
GAIN	13.5	16.5		12	15		10	13		dB
Gain Variation Over Temperature		0.006			0.019			0.017		dB/°C
NOISE FIGURE		2.5	3.5		1.8	2.5		2.7	4.0	dB
RETURN LOSS										
Input		15			13			14		dB
Output			8		15			13		dB
OUTPUT										
Output Power for 1 dB Compression (P1dB)		15			14.5			13		dBm
Saturated (P_{SAT})		18			17.5			16		dBm
Output Third-Order Intercept (IP3) ²		31			29			26		dBm
TOTAL SUPPLY CURRENT		70			70			70		mA

¹ Adjust V_{DD} between -2 V to 0 V to achieve $I_{DD} = 70$ mA typical.
² Measurement taken at $P_{out} = 10$ dBm.

HMC1049LP5E

Data Sheet

ABSOLUTE MAXIMUM RATINGS

Table 2.

Parameter	Rating
Drain Bias Voltage (V_{DD})	10 V
Drain Bias Voltage (RF Out/ V_{DD})	7 V
RF Input Power	18 dBm
Gate Bias Voltage, V_{GG}	-2 V to +0.2 V
Channel Temperature	175°C
Continuous P_{Diss} ($T = 85^\circ\text{C}$) (Derate 37.1 mW/°C Above 85°C)	3.34 W
Thermal Resistance (Channel to Ground Paddle)	26.9°C/W
Temperature	
Storage Temperature	-65°C to +150°C
Operating Temperature	-40°C to +85°C
ESD Sensitivity (HBM)	Class 1A

Table 3. Typical Supply Current vs. V_{DD}

V_{DD} (V)	I_{DD} ¹ (mA)
5	70
6	70
7	70

¹ Adjust V_{DD} to achieve $I_{DD} = 70$ mA.

ESD CAUTION

ESD (electrostatic discharge) sensitive device. Charged devices and circuit boards can discharge without detection. Although this product features patented or proprietary protection circuitry, damage may occur on devices subjected to high energy ESD. Therefore, proper ESD precautions should be taken to avoid performance degradation or loss of functionality.

Stresses at or above those listed under Absolute Maximum Ratings may cause permanent damage to the product. This is a stress rating only; functional operation of the product at these or any other conditions above those indicated in the operational section of this specification is not implied. Operation beyond the maximum operating conditions for extended periods may affect product reliability.

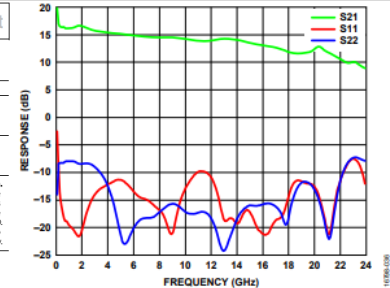

HMC1049LP5E

Data Sheet

PIN CONFIGURATION AND FUNCTION DESCRIPTIONS

Table 4. Pin Function Descriptions

Pin No.	Mnemonic	Description ¹
1, 3, 6 to 12, 14, 17 to 20, 23 to 29, 31, 32	NC	No Connect. These pins are not connected internally; however, all data was measured with these pins connected to RF/dc ground externally (see the Typical Performance Characteristics section for data plots).
2	RFIN	RF Input. This pin is dc-coupled and matched to 50 Ω .
30	V_{DD}	Power Supply Voltage for the Amplifier. External bypass capacitors (100 pF and 0.01 μ F) are required.
21	RFOUT/ V_{DD}	Low Frequency Termination. An external bypass capacitor of 100 pF is required. RF Output/Alternate Power Supply Voltage for the Amplifier. An external bias tee is required when used as alternative V_{DD} . This pin is dc-coupled and matched to 50 Ω .
15, 16	ACG2, ACG3	Low Frequency Termination. External bypass capacitors of 100 pF are required.
13	V_{GG}	Gate Control for Amplifier. Adjust the voltage to achieve $I_{DD} = 70$ mA. External bypass capacitors of 100 pF, 0.01 μ F, and 4.7 μ F are required.
4, 22	GND	Ground. Connect Pin 4 and Pin 22 to RF/dc ground.
0	EP	Exposed Pad. The exposed ground paddle must be connected to RF/dc ground.

¹ See the Interface Schematics section for pin interfaces.

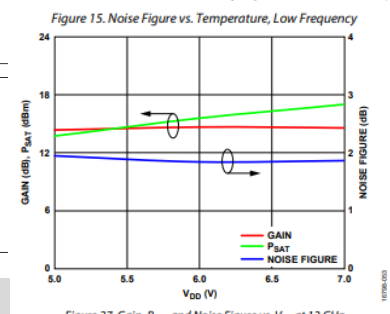
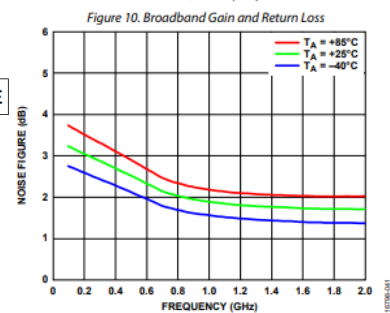

Simulation - LTspice

- Schematic Level
- Layout Level
- Structural model – SPICE
- Behavioral model – IBIS
- Scattering model – S-parameter

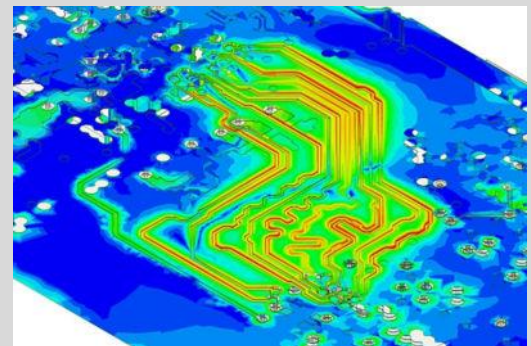
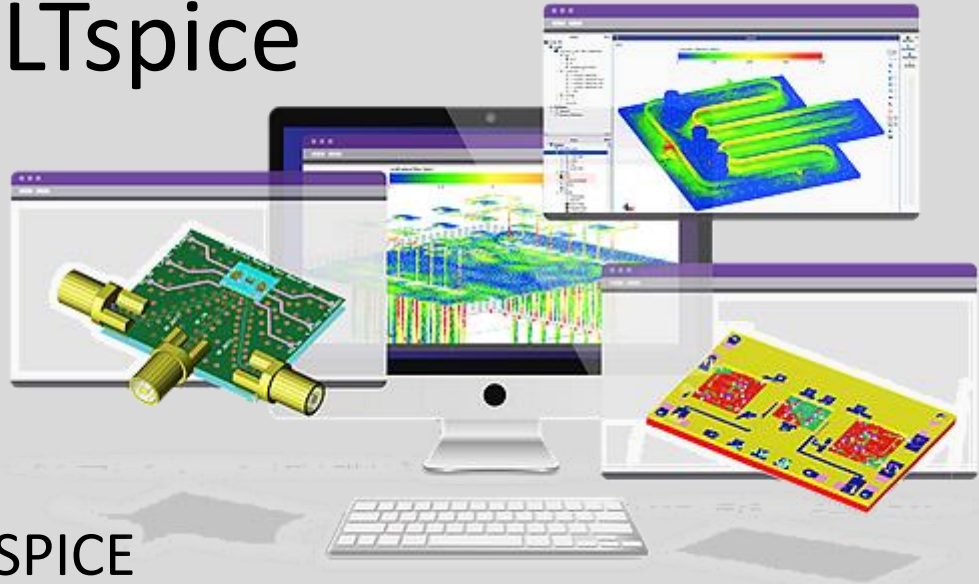

Simulation - LTspice

- ADS by Keysight
- Electronics Desktop by Ansys
- LTspice by Analog Devices
- Qucs (under GPL license)

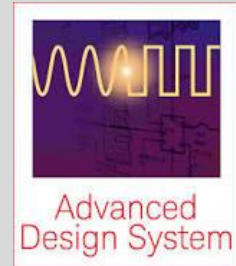

Simulation - LTspice

- Transient
- AC
- DC Sweep
- Noise

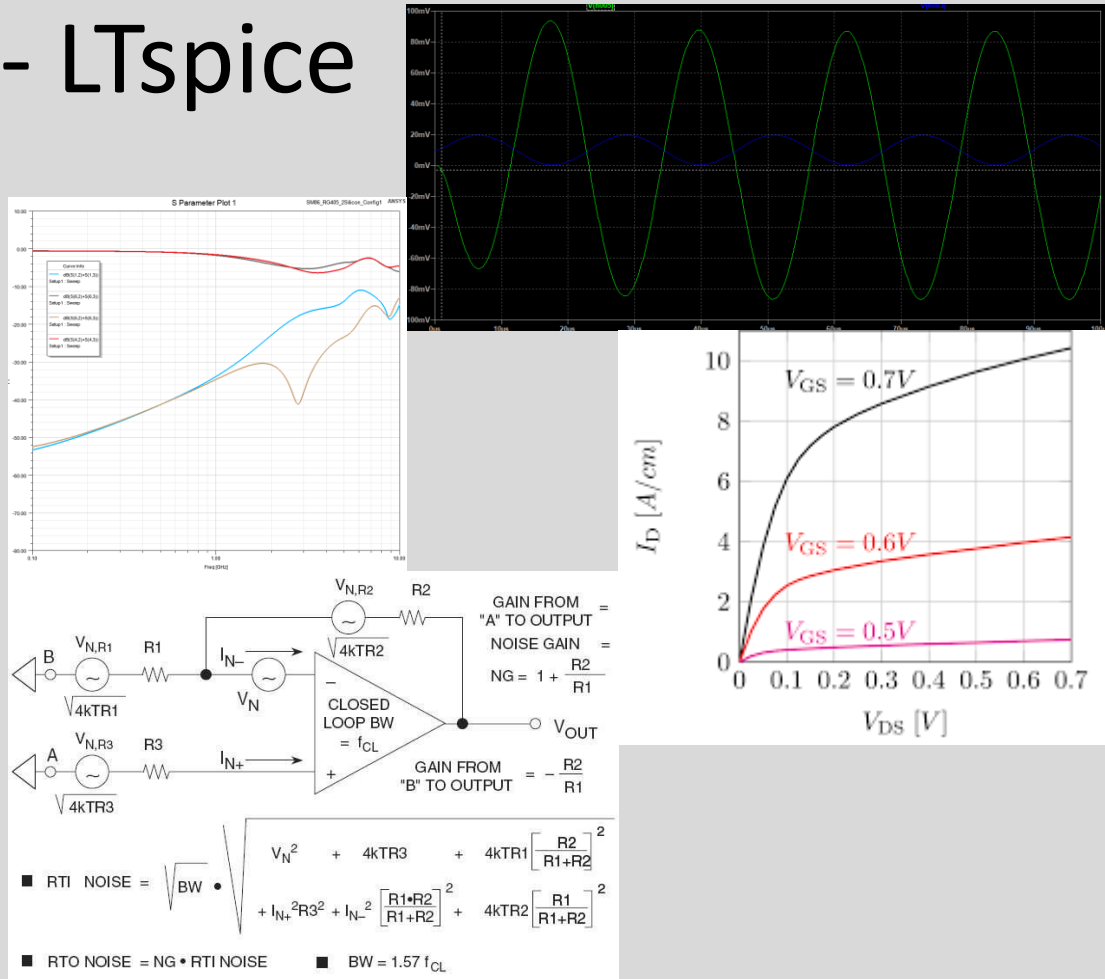

Simulation - LTspice

- Layout Level - SIwave

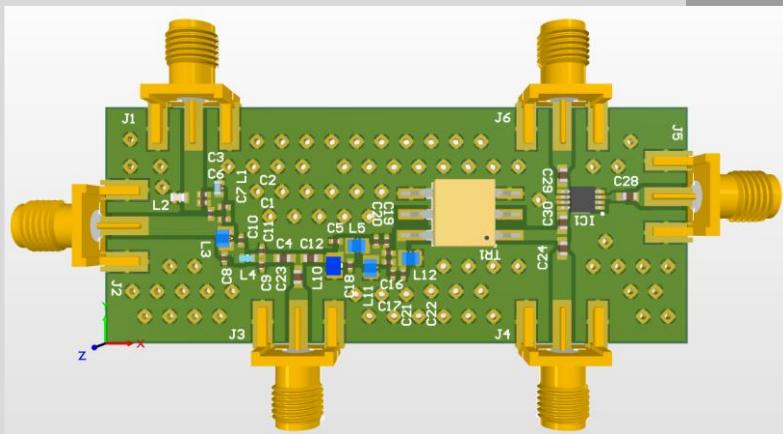
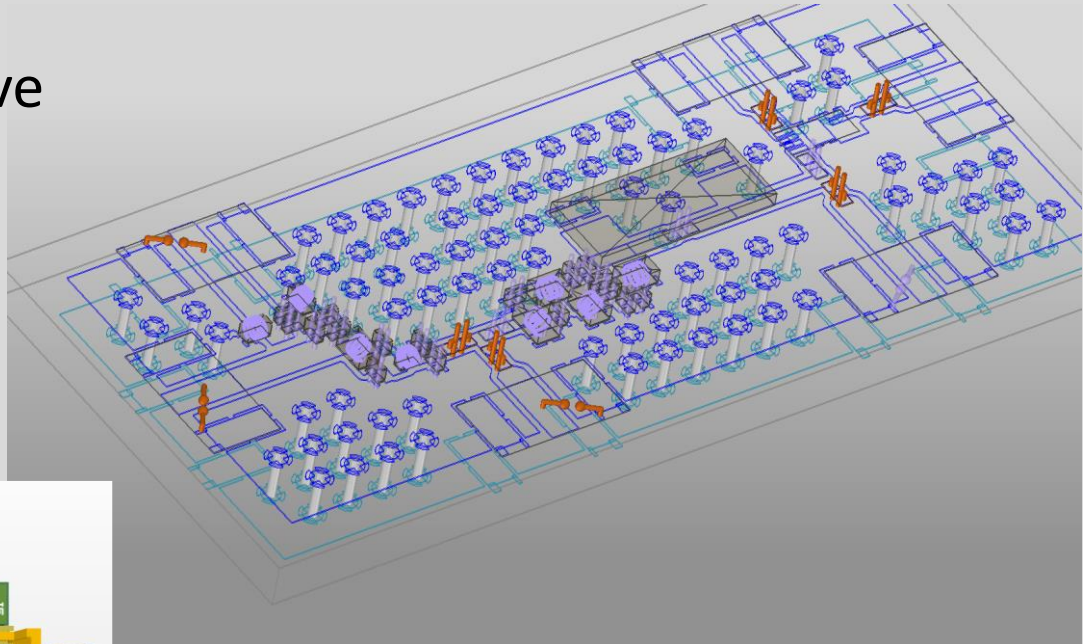

Simulation - LTspice

- Transient
- AC
- Noise

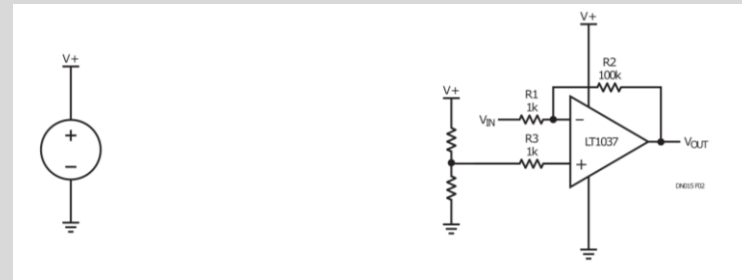

Simulation – Qucs – Match Circuit



Low Noise Amplifier,
0.01 GHz to 10 GHz

Data Sheet

HMC8411LP2FE

FEATURES

- Low noise figure: 1.7 dB typical
- Single positive supply (self biased)
- High gain: 15.5 dB typical
- High OIP3: 34 dBm typical
- 6-lead, 2 mm x 2 mm LFCSP

APPLICATIONS

- Test instrumentation
- Military communications

FUNCTIONAL BLOCK DIAGRAM

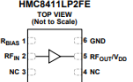

Figure 1.