

# Cryogenic Current Comparator for nA beam current measurement in FAIR

Lorenzo Crescimbeni

Beam Diagnostics Group, GSI



Bundesministerium  
für Bildung  
und Forschung

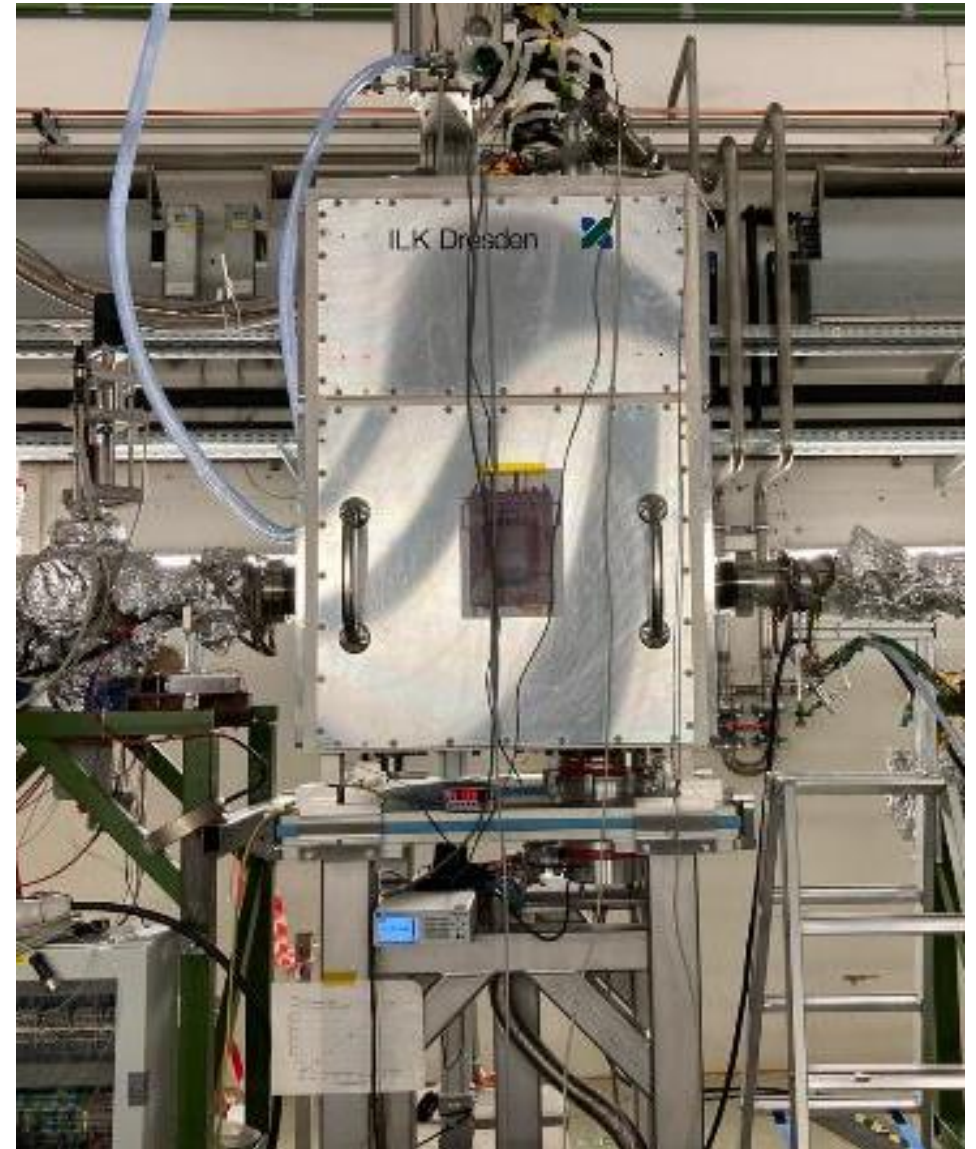

- Motivation of the CCC development
- Operating Principle
- Challenge and goal of the CCC
- First viability test of FAIR CCC in an accelerator environment
- Improvement to the system
- Different CCCs are possible?
- Future steps and conclusions

## Why we need the CCC?

- There is a Gap in the actual non destructive diagnostics:

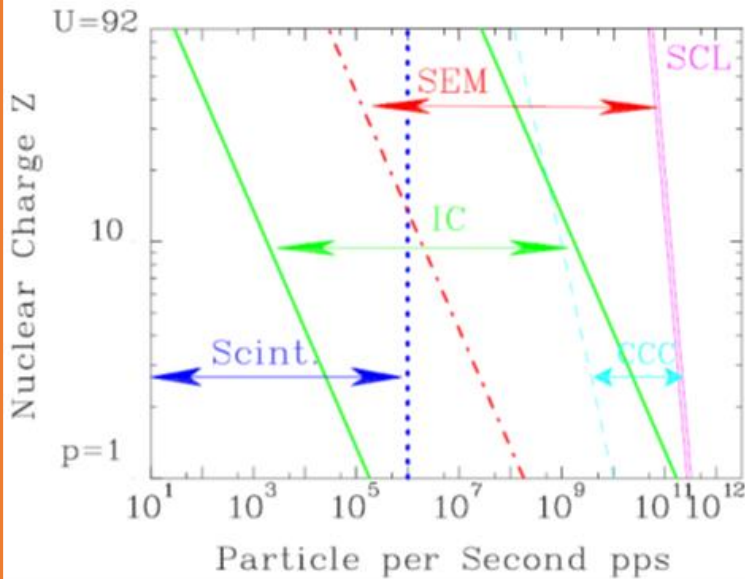

- Detector system used for slow extraction at SIS18: (P. Forck)
  - SCL... Space charge limit
  - IC... Ionization Chamber
  - SEM... Secondary electron monitor

## And its operating principle?

### Cryogenic Current Comparator Schematic

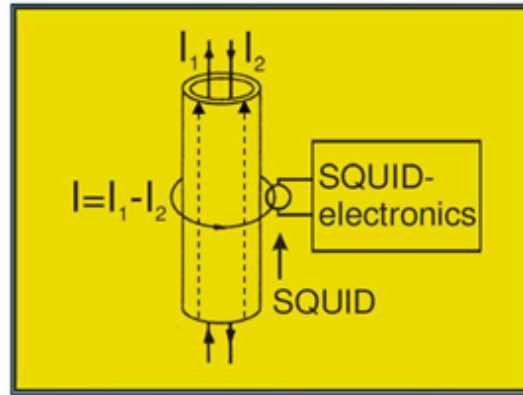

#### CCC (Harvey 1972):

- Uses Meissner-effect and SQUID for  $I_1/I_2$  measurement
- If  $I_1 \neq I_2$  magn. field produces compensation current
- Magnetic flux through SQUID  $\rightarrow$  voltage change

#### For charged particle beams:

$$I_{comp} = I_1 - I_2 = I_{beam} - 0 \quad (\text{position independent})$$

DC-SQUID magnetometer  
(Superconducting Quantum Interference Device)

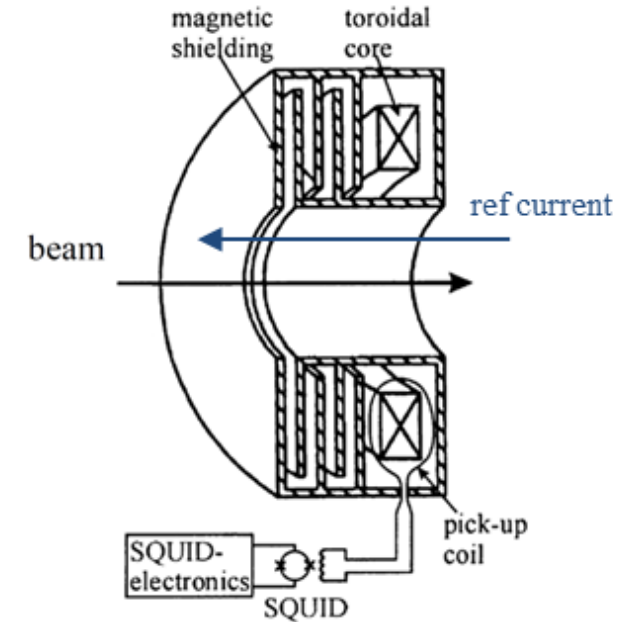

- SC shielding for non-azimuthal fields
- SC pickup coil with toroidal core ( $\mu_r \approx 50000$ )
- Low noise, high performance DC SQUID control electronics (FSU Jena)

Commercially available version by MAGNICON or SUPRACON

# Goal of CCC and challenges

- The goal of the work on the CCC it's to have a non destructive measurement of low beam current, both for bunched and unbunched beams, with a resolution up to 1 nA, while being easy to calibrate and independent from several beam condition
- Obviously this bring several challenges, correlated to different aspects of the detector
- The Signal coming to the SQUID has to be shielded from external perturbation, the prevalent ones are:

## MAGNETIC FIELDS

Static (Earth):  $\sim 50 \mu\text{T}$   
 Dynamic (Ramped dipole):  $\sim 10 \mu\text{T}$

Much bigger than:

Field of 100 nA ion beam:  $\sim 150 \text{ fT}$   
 (10 cm distance)

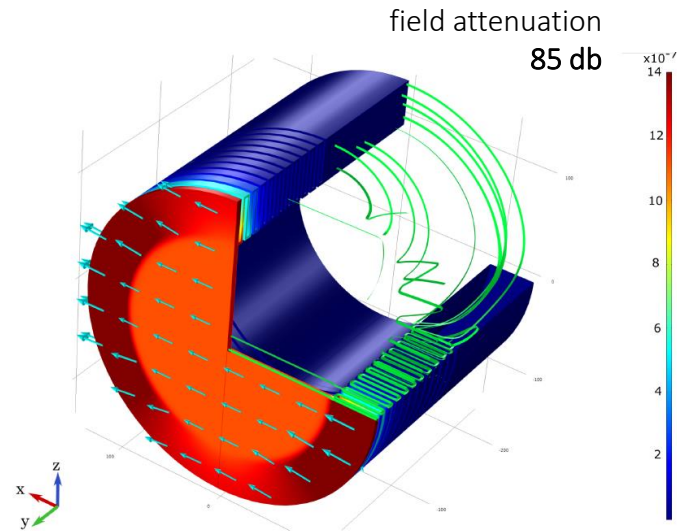

Simulation of field attenuation with Comsol Multiphysics® (F. Kurian)

## TEMPERATURE/PRESSURE

Drift of 73.7 nA/mbar  
 33.5 nA/mK

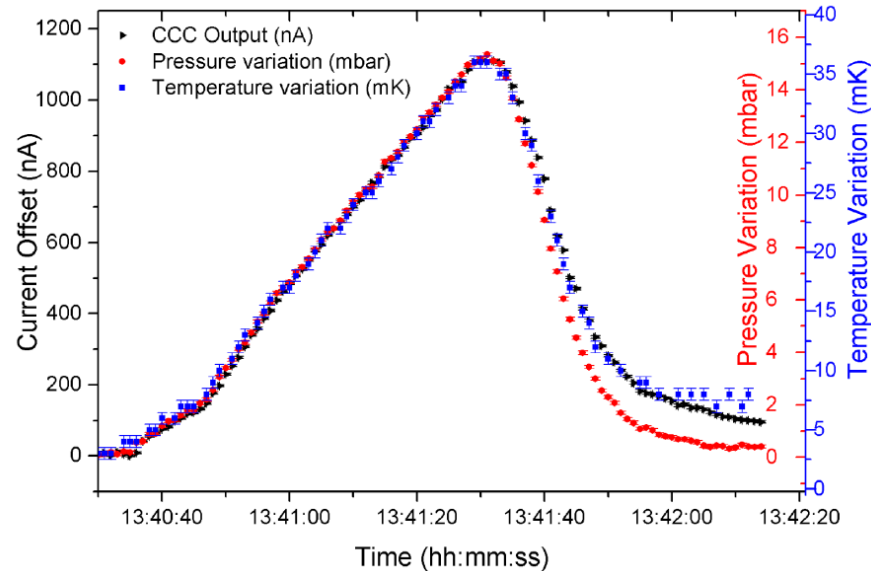

Current offset due to pressure and temperature variation.

## VIBRATIONS/ACOUSTIC

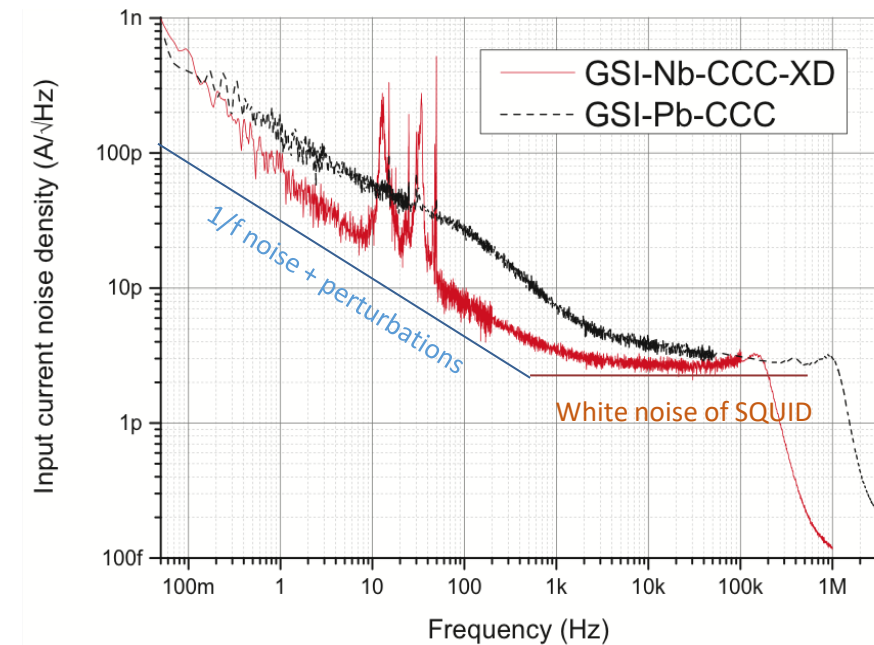

Current noise density of background measurement in the lab.



# CCC: test in controlled environment

- The CCC has been tested in the laboratory, where there are a low quantity of external perturbation to verify the estimated resolution ( $<10$  nA)
- In the magnetically shielded laboratory CCC has been tested in a custom cryostat with a calibration pulse of 1.65 nA
- The CCC is clearly able to resolve the input pulse
- The next step is to verify a similar resolution also in the accelerator environment:

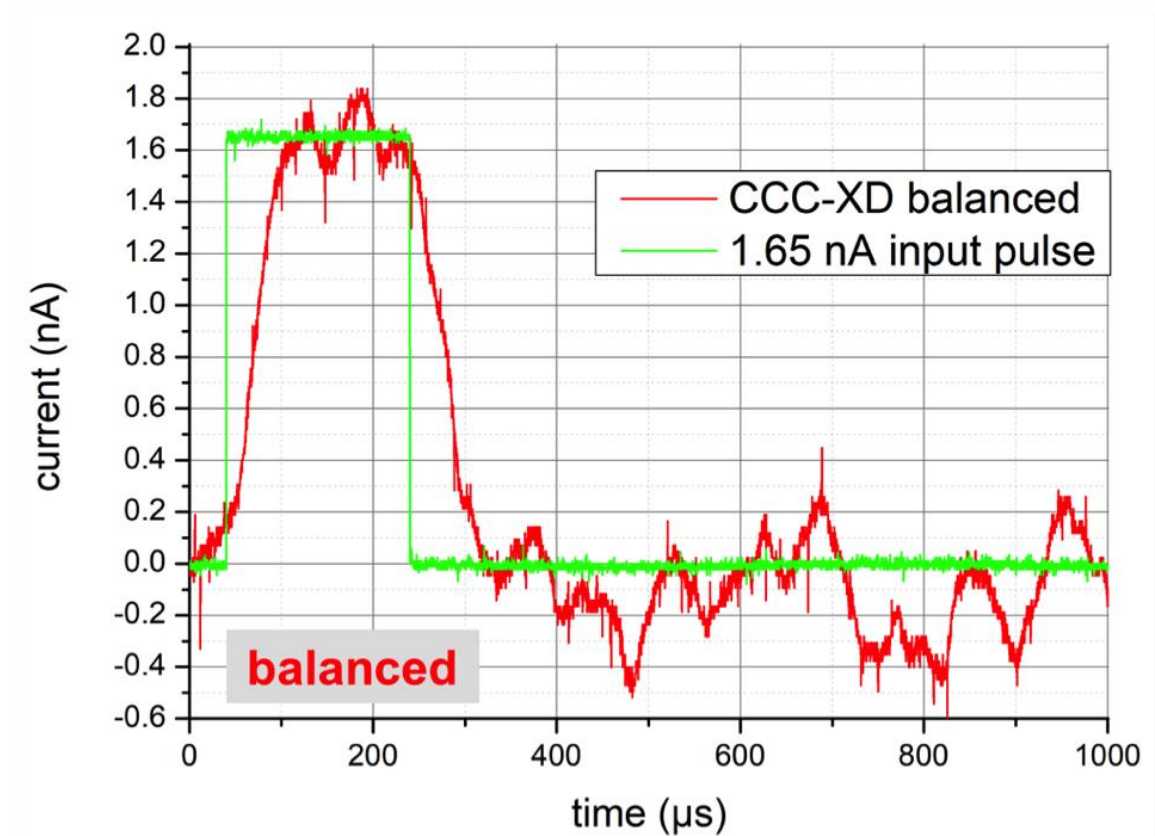

# Closed Cryogenic System: Cryostat

- To be able to operate the CCC it's necessary to use a closed cryogenic system, able to keep it at a stable temperature and pressure.
- The cryostat has to be installed in the beamline, and has to be provided of an insulant gap allow the operation of the CCC

- Dimensions:** 850 x 850 x1200 mm (1.1 ton)

- Main Parts:

- External Cryostat: Al, several maintenance windows that allows operations inside, vibration damping thanks to bellows and damping supports
- UHV beamline: bakeable, vibration damping thanks to bellows
- Thermal Shield (gas cooled) : Copper, shields the helium vessel from heat input, covered in MLI to reduce heat load, Ti6Al4V suspension rod to hold it
- Helium vessel: Al, 80l, allocate the CCC
- Helium tube: Vibration damping, ceramic gap
- Liquifier: 19 L/day, ensure long term operations

- The cryostat has been developed for the use in FAIR and optimized for the FAIR-Nb-CCC-Xd

This CCC, made of Niobium, has a radial geometry and it's part of the CCC-XD used in large beam-lines (es Antiproton Decelerator at CERN) adapted to the beamline dimension of FAIR ( $\phi$  150 mm)

SQUID cartridge Meanders structure

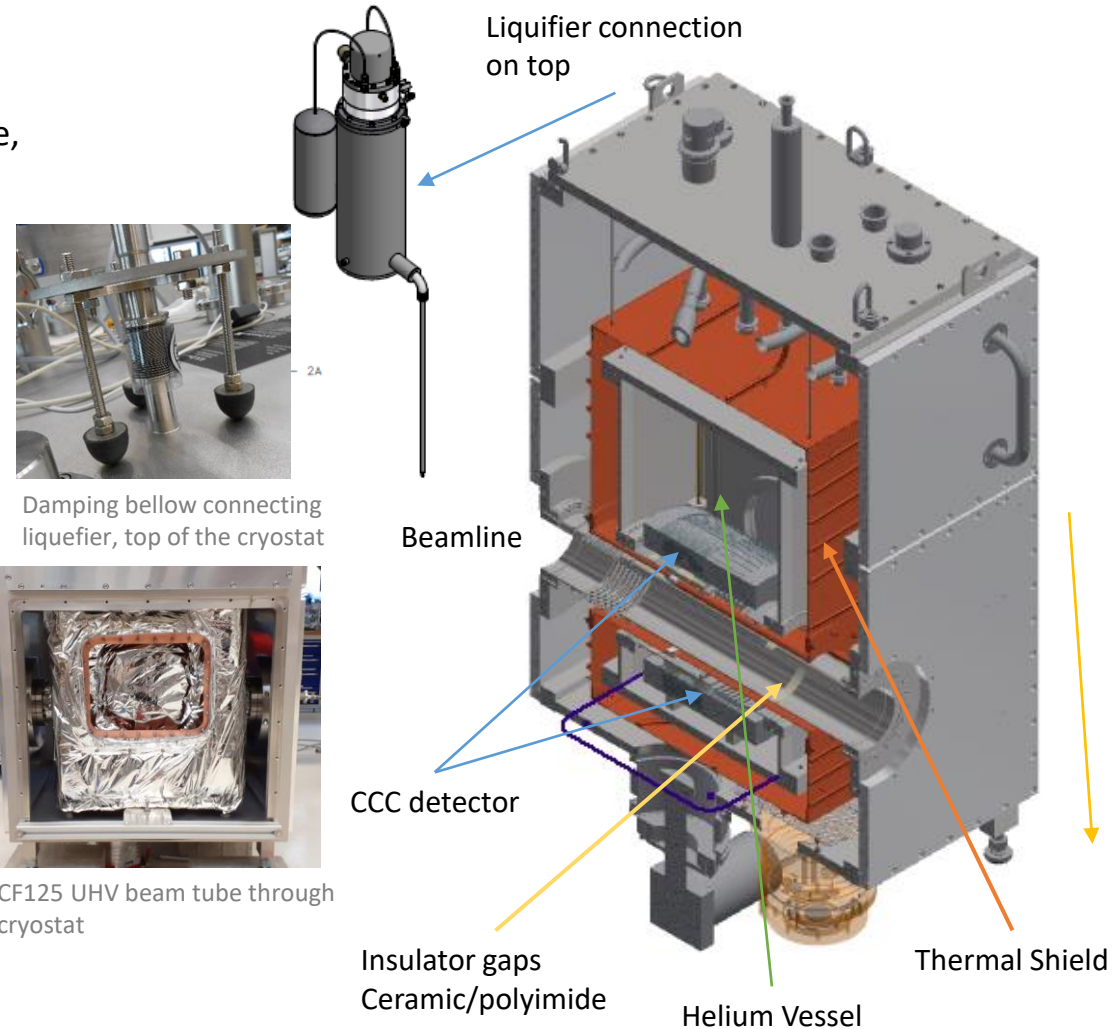
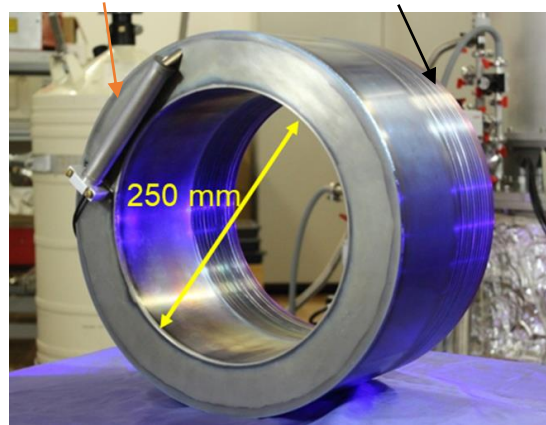

Damping bellow connecting liquefier, top of the cryostat

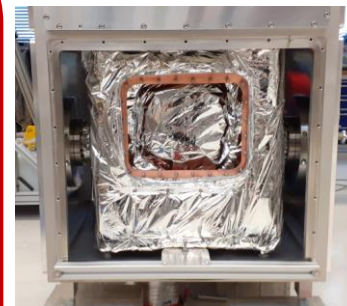

CF125 UHV beam tube through cryostat



- The CCC has been tested in CRYRING@ESR an heavy ion storage ring in GSI. This test allows to confirm the viability of this prototype for FAIR
- To be able to use the CCC in a noisy environment like an accelerator the setup needs to provide additional dampening of mechanical oscillation, this is achieved using several dampening systems
- The liquifier ensures long term operation
- The cryostat itself ensures a stable operating pressure and temperature

## GOALS

- Test of the CCC resolution in the accelerator environment
- Test of measurement with different beam species
- Test of measurement range from 5 nA to the maximum current detectable by CCC (73 mA)

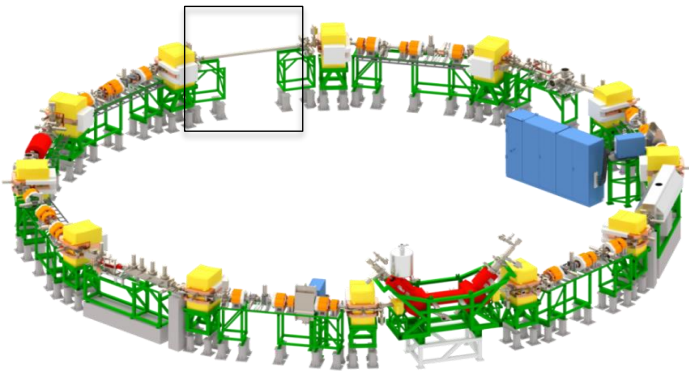

### CRYRING@ESR:

- Universal storage ring
- **Circumference:** 54 m
- **Magnetic Rigidity:** 0.8 Tm
- **Proton energy:** <30 MeV

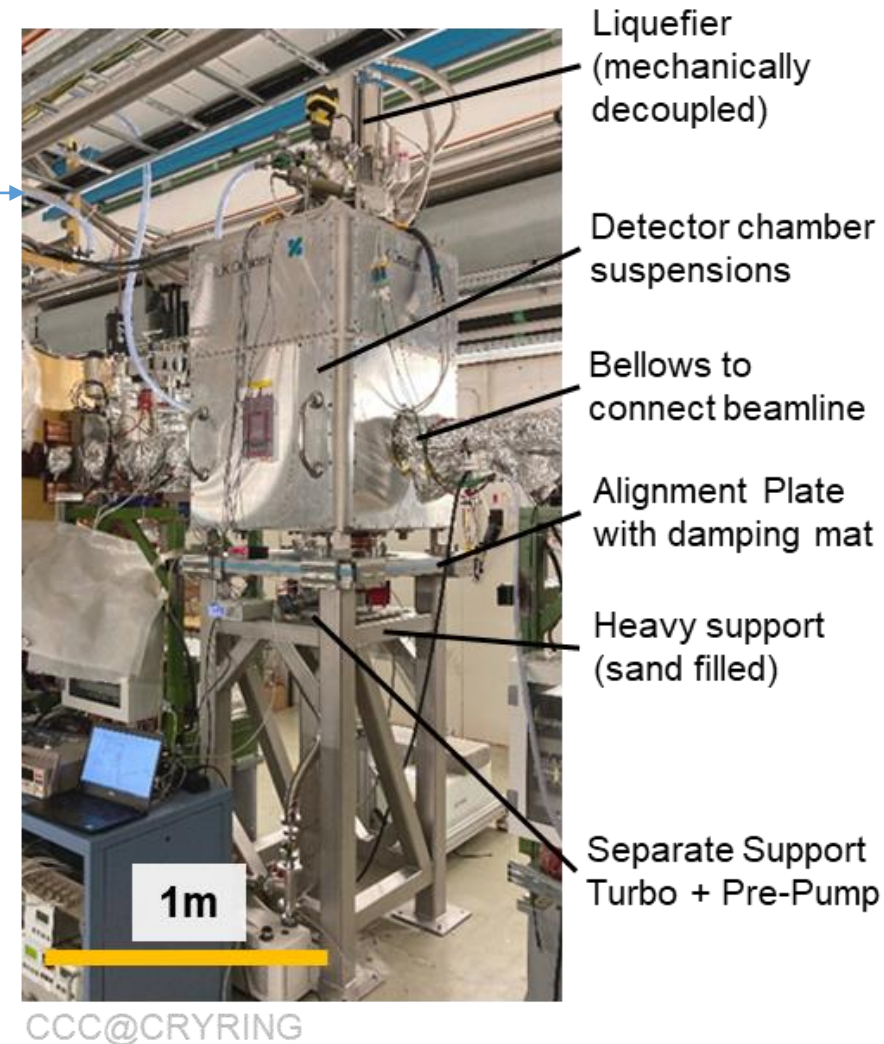

TEK36 - 28. Nov 2020  
Input: 21.2 nA of calibration current (1 kHz square wave)

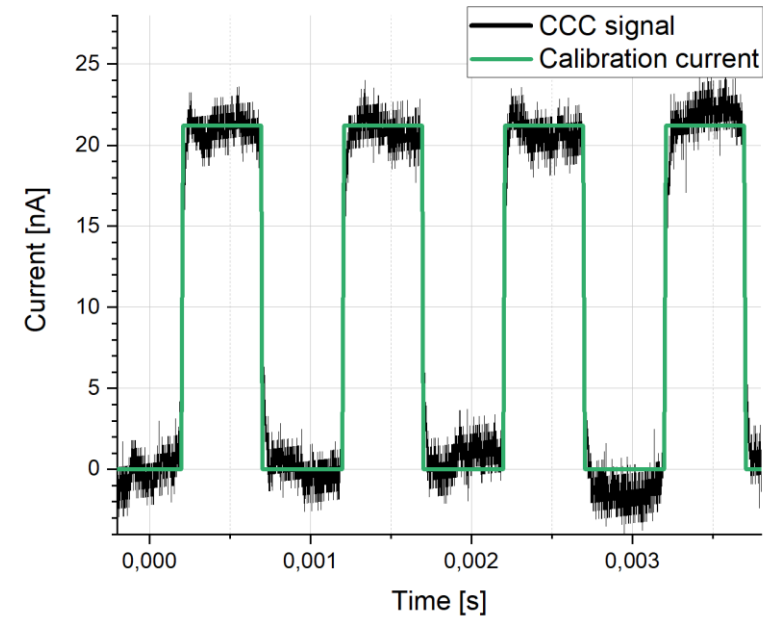

- Using a square wave at 1 kHz as input it's possible to verify the correct calibration of the CCC and the effectiveness of the software filters to remove the systematic noise



TEK36 - 28. Nov 2020

Input: 21.2 nA of calibration current (1 kHz square wave)

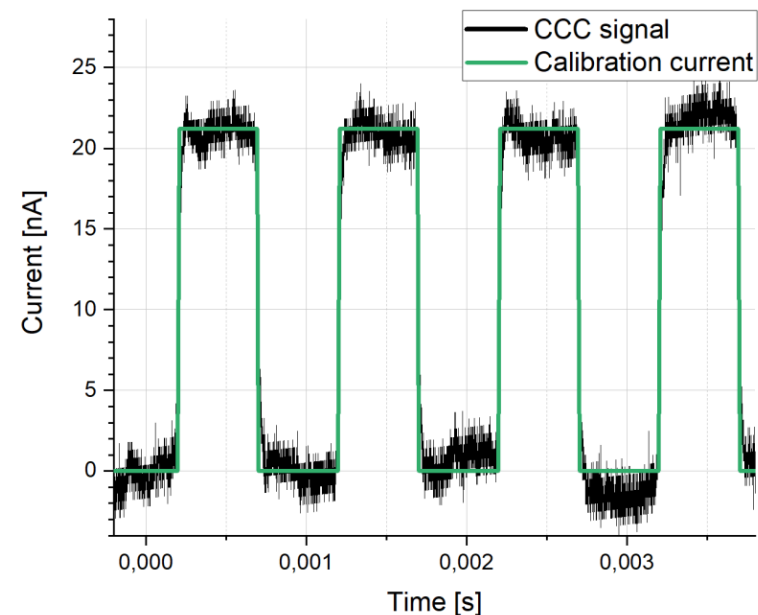

- Using a square wave at 1 kHz as input it's possible to verify the correct calibration of the CCC and the effectiveness of the software filters to remove the systematic noise
- It's then possible to verify the CCC performance measuring a low intensity Deuterium beam ( 5 MeV/u at flat top)
- The beam phases are clearly visible, even if the "raw" CCC signal is affected by noises
- The noise contribution is mainly due to the intrinsic noise of the magnetic core and to external perturbation

- For Dc beam current measurement it's possible to apply a low pass filter (20 Hz) by performing a time average of the CCC data, this operation strongly attenuates the noise

**Noise limited current resolution:**

**<10 nA**

(the same found in previous laboratory test)

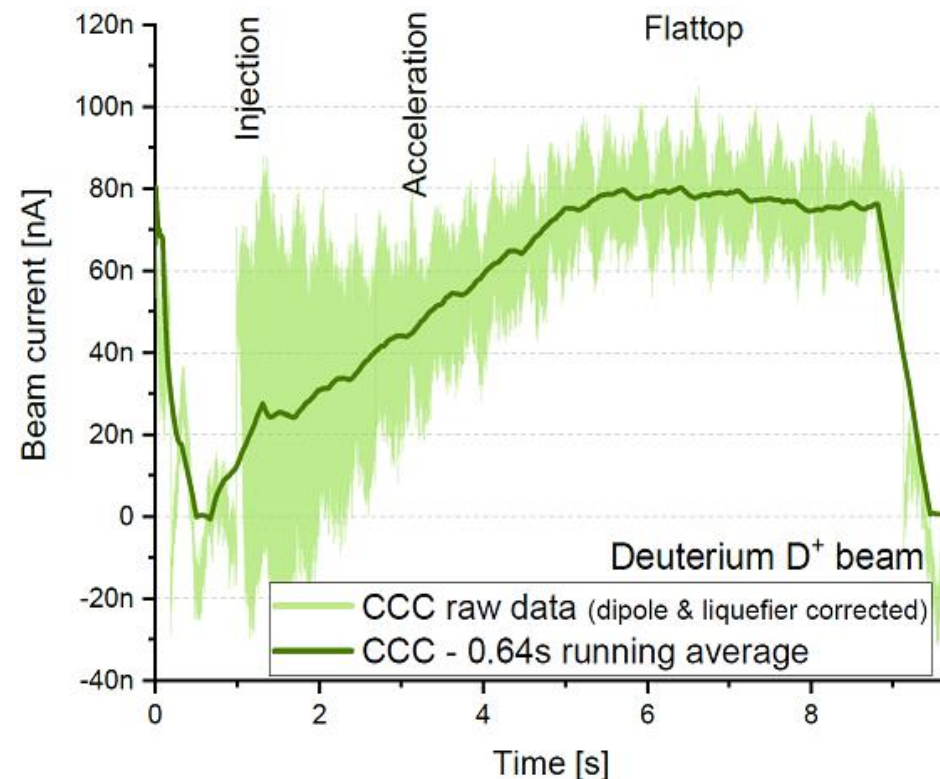

- Even if the results of the test in CRYRING confirm the reliability of FAIR CCC has a diagnostic instrument there are still some limitations that has been exposed and needs to be solved:

## Cryogenic Limitations

- The liquifier ensures at the moment only 7 days of operation
- This is due to excessive heat load on the line and excessive heat input inside the cryostat itself

## Slew Rate Limitations

- The CCC is designed to monitor small, gradual, changes of beam intensity.
- If the intensity are larger, it's possible to exceed the slew rate limit of the detector (**0.16  $\mu\text{A}/\mu\text{s}$**  [ $f < 200$  KHz])
- Excessive slew rate lead to local artefact of the measurement or to offset on the measurement

## Low magnetic screening factor

- During the measurement in CRYRING it was possible to observe the dipole ramp of the magnets in the measurement performed with the CCC
- In CRYRING it was possible to filter out the magnetic noise because the dipole ramps are well known and really similar, but it's not always the case

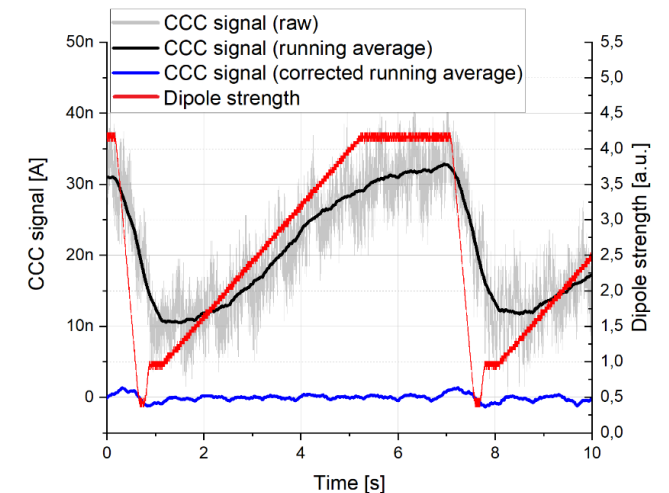
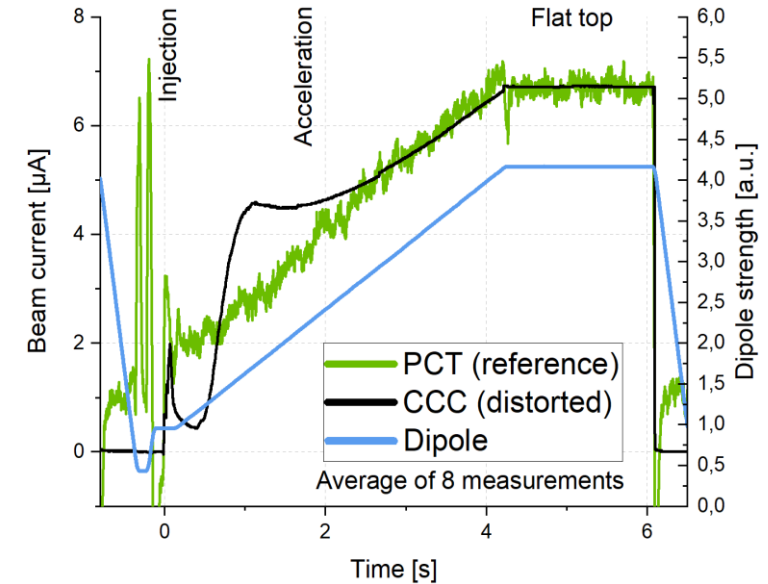

# Cryogenics limitation

- In CRYRING the standing time of the CCC was nearly a week, while it should be unlimited
- The first step is to reduce the heat input on the He-vessel:
  - New MLI to improve thermal insulation
  - Improved isolation vacuum



- Next step is to improve the efficiency of the liquifier:

- We have found out that controlling the amount of gas reaching the liquifier al

to reduce the evaporation rate  
Different setting of the valve for flow control shows really different evaporation rate:

- No flow control : 9 l/day (valve completely opened)
- High resistance: 20 l/day (flow control valve almost closed)

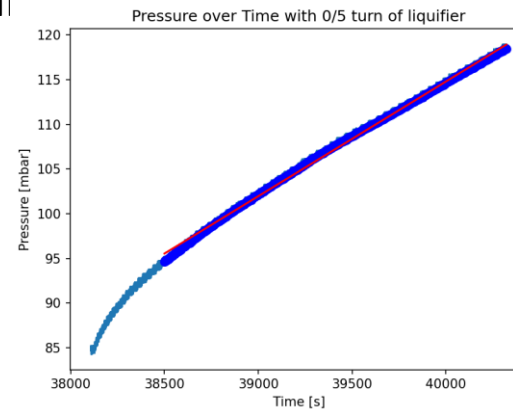

Reducing the overcirculation of gas through the liquifier decrease strongly the evaporation rate of helium, but is still not enough

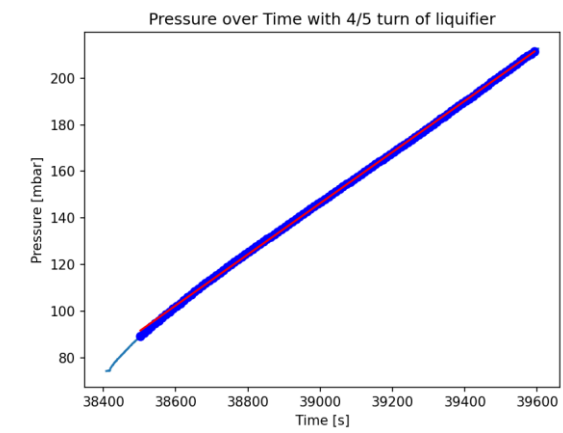
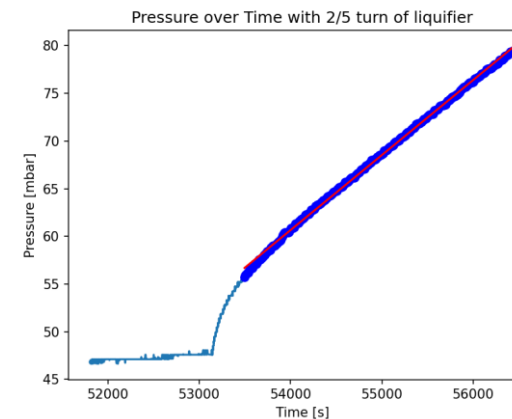
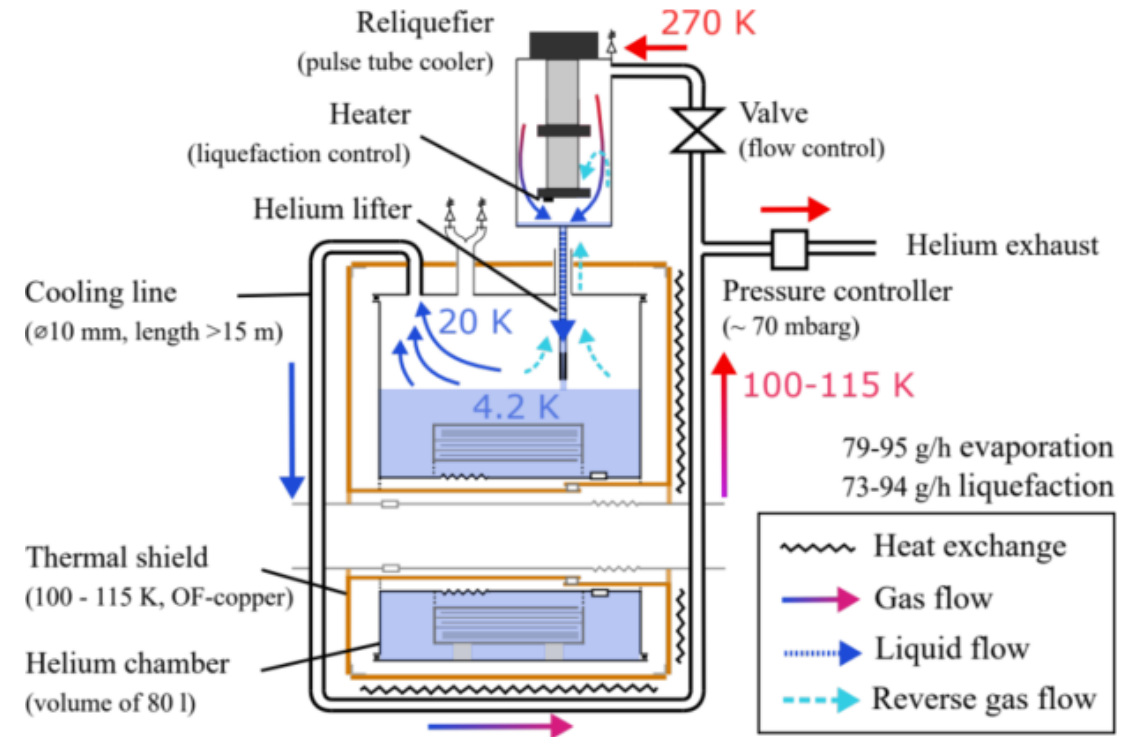



- To improve the system further we are working on a new thermal shield and on a liquifier improvement
- Our liquifier is now able to liquify 15 l/day of helium, while the evaporation rate of our system is between 20-23 l/day, depending on the settings of the flow control system, we are upgrading the system to a 25 l/day liquifier, allowing to reach an unlimited standing time
- In parallel we are working on an improved version of the existing copper thermal shield:
- Improved return line: bigger diameter and shorter length to reduce line resistance
- Rectangular section to improve thermal conductivity between cold line and main shield structure

The new shield will also reduce the 1.4 Hz periodic noise of the liquifier (compressor frequency). A shorter return line reduce the amplitude of the periodic noise, so the new shield will reduce the intensity of the noise

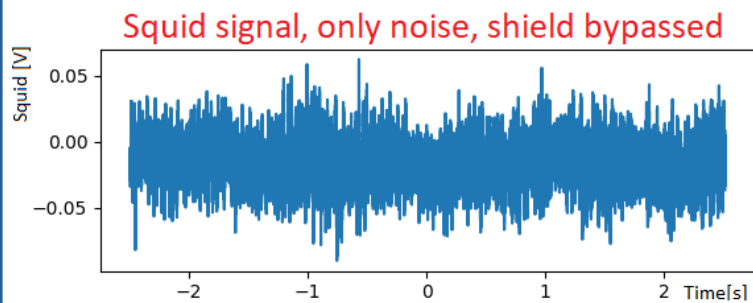
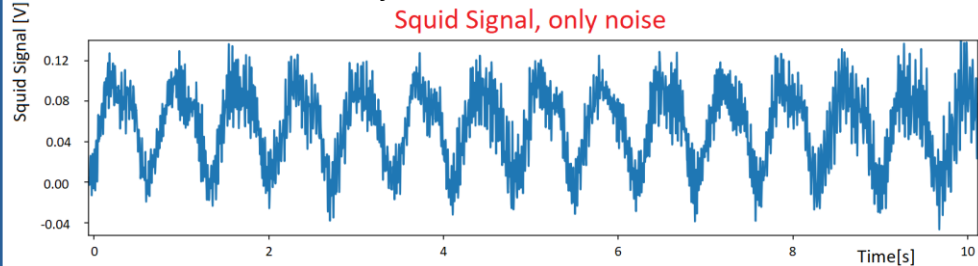

We were able to remove the noise by bypassing the return line, the amplitude of the noise depends on the length of the line.

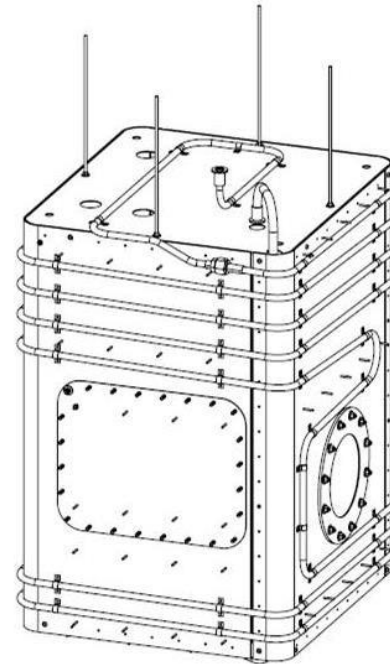

Existing shield drawing: 15 m return line of round section of 10 mm diameter



# A different geometry: Axial CCC

## Radial CCC with Core    Axial Coreless CCC

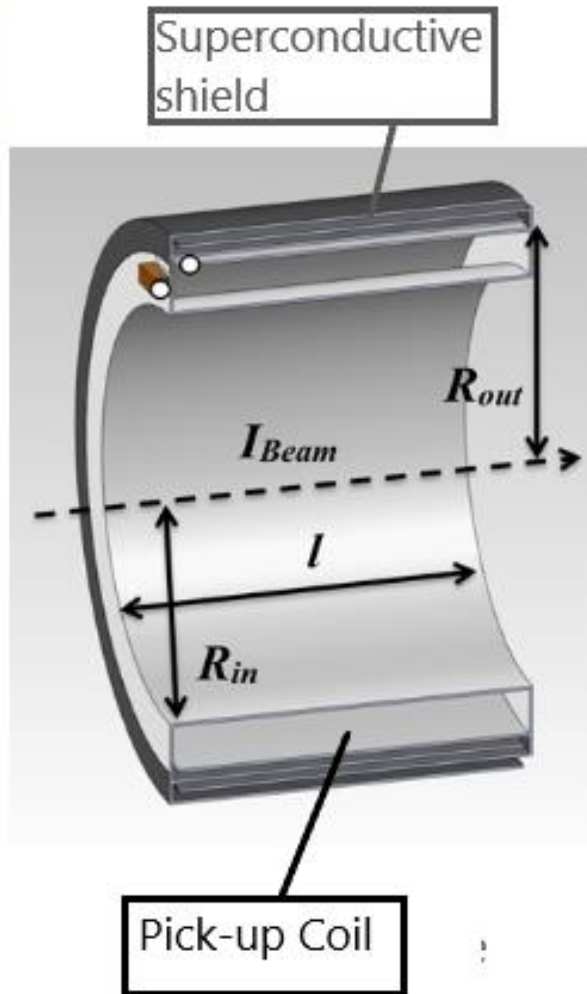
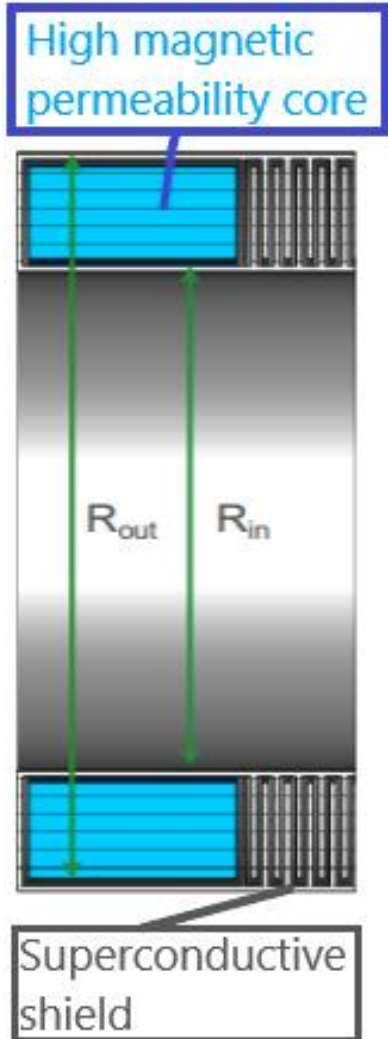

- To improve the magnetic screening factor to most efficient way is to change the geometry of the CCC
- This is why an axial CCC has been designed
- In the axial CCC the meander structure covers all the surface of the CCC, in this way the effective area of the meanders is much higher
- The axial geometry allow also to test the idea of a Coreless CCC
- The high magnetic permeability core strongly improve the coupling of the SQUID with the beam, at the cost of a much higher low frequency noise and a reduced bandwidth
- The low frequency noise ( $< 1$  Hz) come from magnetic field caught inside the core material during cooling
- The radial CCC with core is basically an LC circuit, with an high inductance coming from the core and a capacity coming from the meanders. This means that we need to add a low pass filter to avoid signal with frequencies close to the resonance frequency, reducing the effective bandwidth of the system

# Axial Coreless CCC

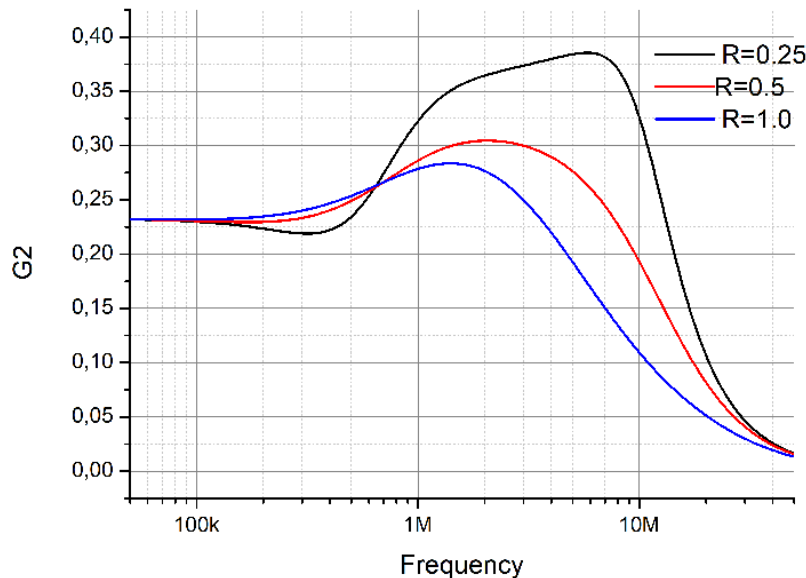
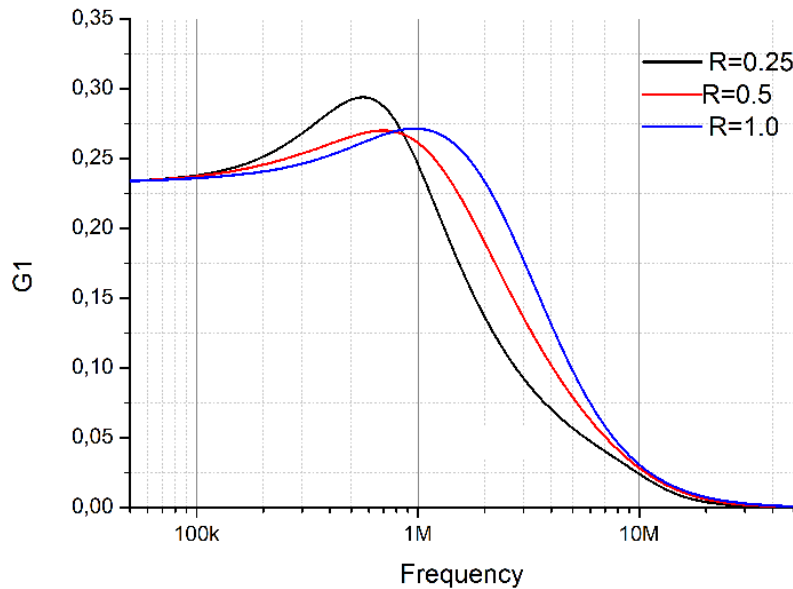

- To increase the slew rate of the detector the axial coreless CCC will be equipped with a cascade SQUID system composed of two parallel working squid, one with a lower bandwidth and higher resolution and the other with an higher bandwidth and a lower resolution

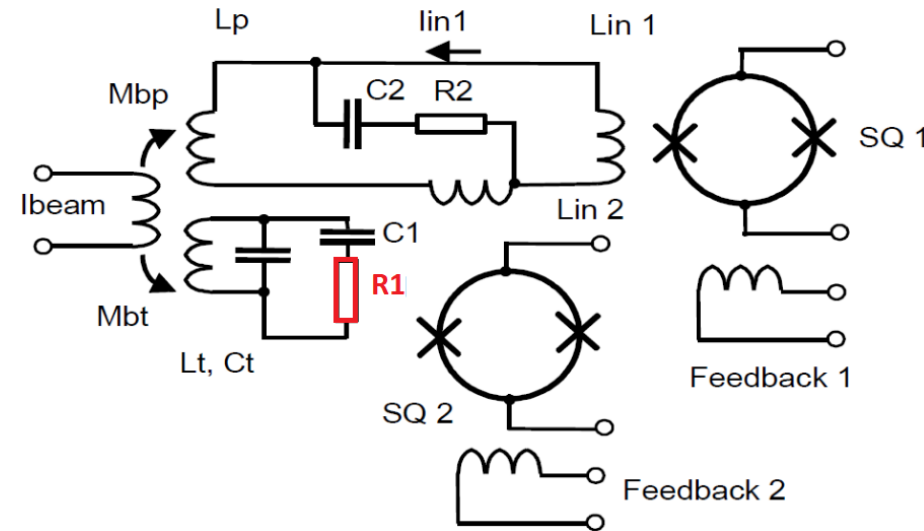

- The components of the circuit has been chosen to optimize the transfer function of the system
- The bandwidth of the axial coreless CCC can then be much higher then the one of the existing device, allowing to reach much higher slew rates.
- The Axial Coreless CCC has been designed using Lead as material, instead of niobium, this means that the cost of production is much lower and that it doesn't need complicated techniques to be built
- The first prototype of the axial coreless CCC has been built in collaboration with IPHT Jena



# Axial CCC construction

- The First prototype of the Axial CCC has been built in the laboratory of IPHT Jena
- It's a 10 layers meander structure welded around a fiberglass cylinder for mechanical support

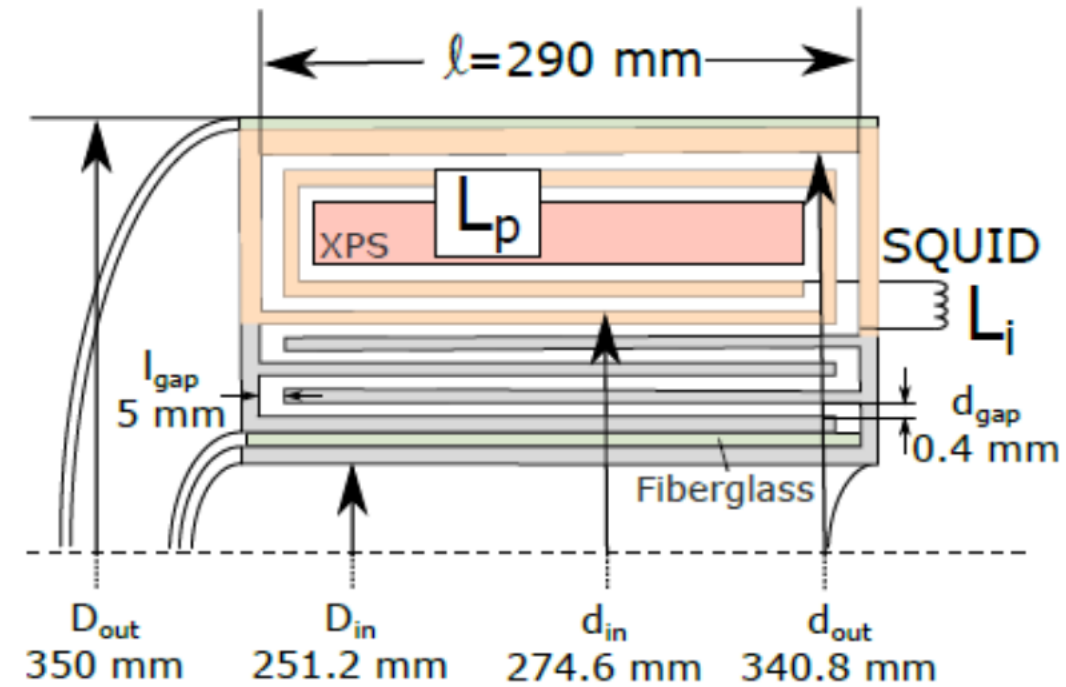
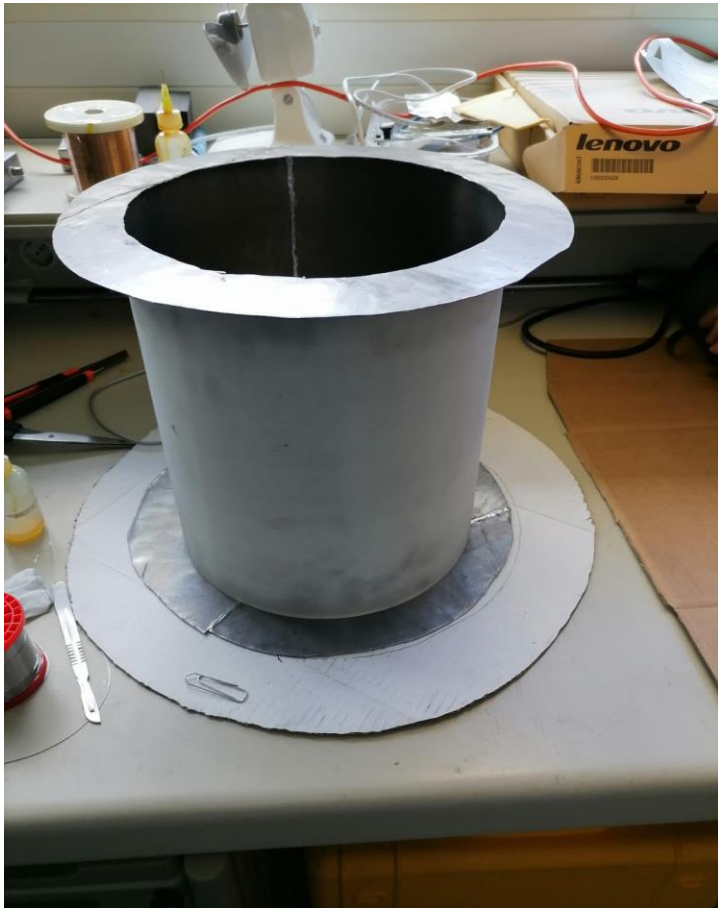

- In the picture it's possible to see the fiberglass cylinder and the bottom and top cap of the CCC, made out of 1mm thick sheet of Pb.
- The inside layer is also built of 1mm thick sheet of Pb

# Axial CCC construction

- It's possible to see the first layer of the meander structure welded to the bottom cap. The layer are built out of 0.25 mm sheet of lead.



- Between each layer there is a layer of insulating material to provide electrical insulation of the meanders
- On the right the structure of the pickup coil, placed once the meander structure has been completed
- The foam is non magnetic and placed for mechanical support
- 2 pickup coil, once again made out of 0.25 mm lead sheet are built around the foam
- The CCC is then enclosed in a fiberglass cylinder to protect the pickup coil and closed with the last layer of lead
- The two squids are then connected to the pickup coil trough two lead strips
- The squids are then enclosed in a lead box on top of the CCC





# Test of axial CCC in Jena

- Once the CCC has been completed, it has been tested in the laboratory at FSU jena, in the wide neck cryostat

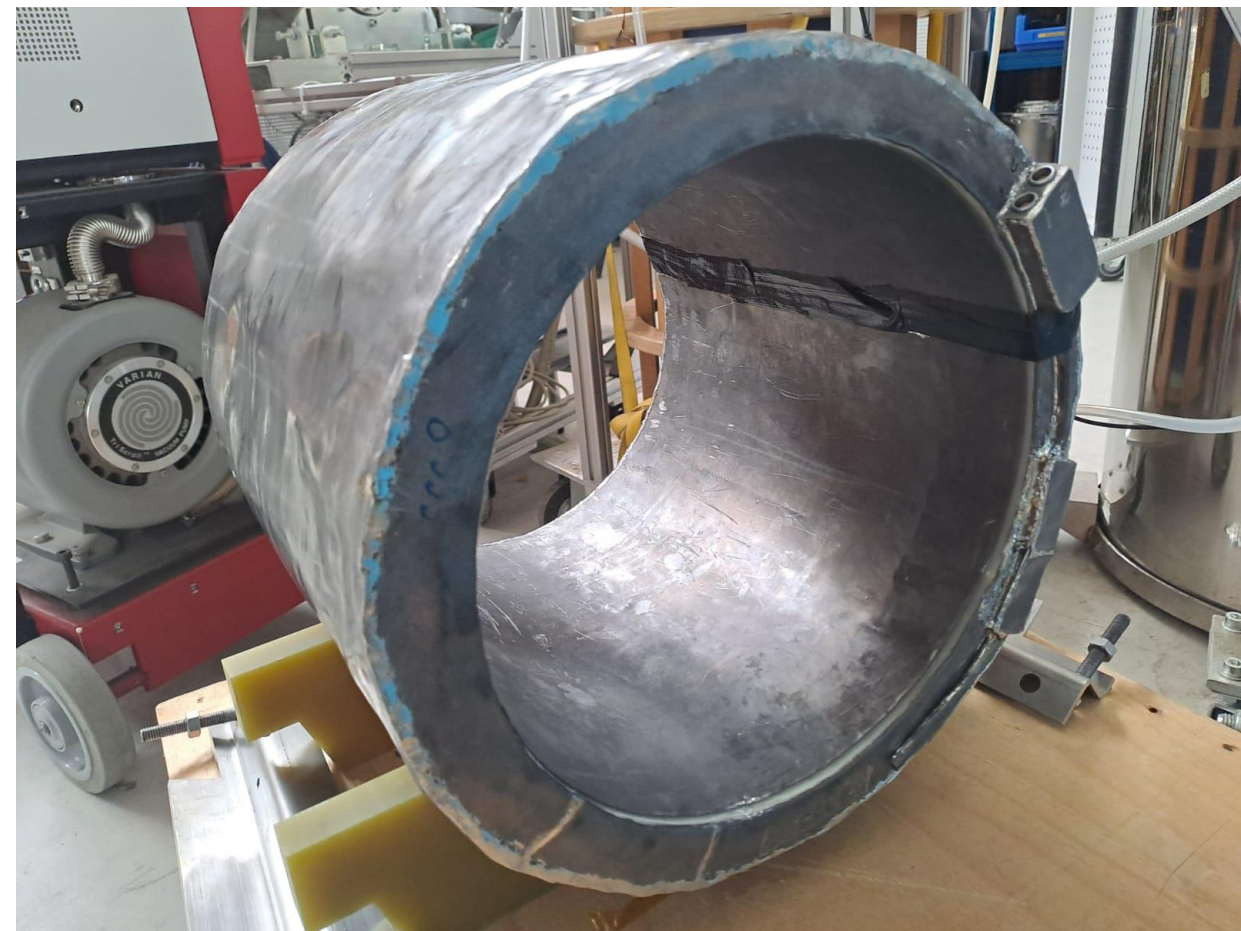

Axial coreless CCC completed, the squid box can be seen on top, together with the connector box





- **Current Resolution:** It was possible to estimate the maximum current resolution of the axial CCC.
- The maximum resolution is in order of 10 nA, 10 times worse than the radial CCC
- A lower resolution was expected, due to the lower coupling of the SQUID with the beam
- What was unexpected was the noise, that is more than 10 times higher than the noise found out with the radial CCC in the same laboratory, that was around 0.1 nA.

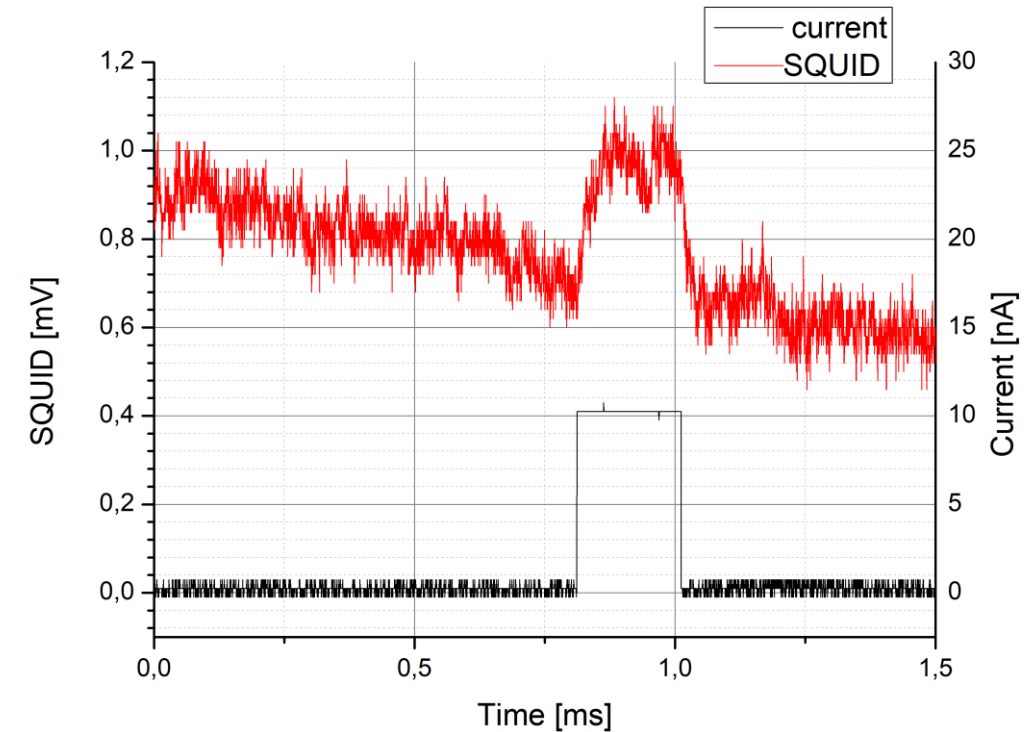

- **Slew Rate:** Even if the setup of the laboratory in Jena is not optimized to have the optimal slew rate it was possible to perform a first estimation of the slew rate of the axial coreless CCC
- We measured a slew rate of 4  $\mu\text{A}/\mu\text{S}$ , a strong improvement from the 0.16  $\mu\text{A}/\mu\text{S}$  of the radial CCC
- It's possible to improve the slew rate even more with the optimal setup in GSI
- This will allow to use the axial coreless CCC to monitor a much higher spectrum of signal without decreasing the current resolution of the detector itself

- **Magnetic Screening Factor:** The FSU cryostat is equipped with a pair of Helmholtz coils to provide a magnetic field up to 1 mT.

- **RADIAL CCC IN GSI:** with similar Helmholtz coils we have tested the radial CCC in GSI, measuring a screening factor in the order of **70 dB**
- This means that to a field of 100  $\mu\text{T}$  correspond a signal of around 10 nA from the squid

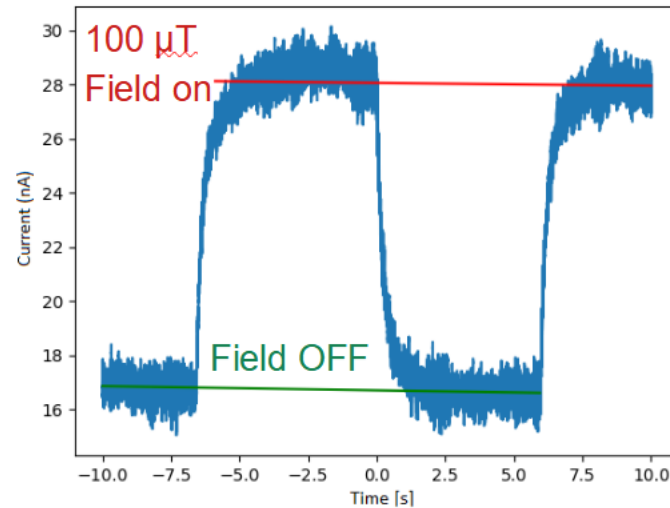
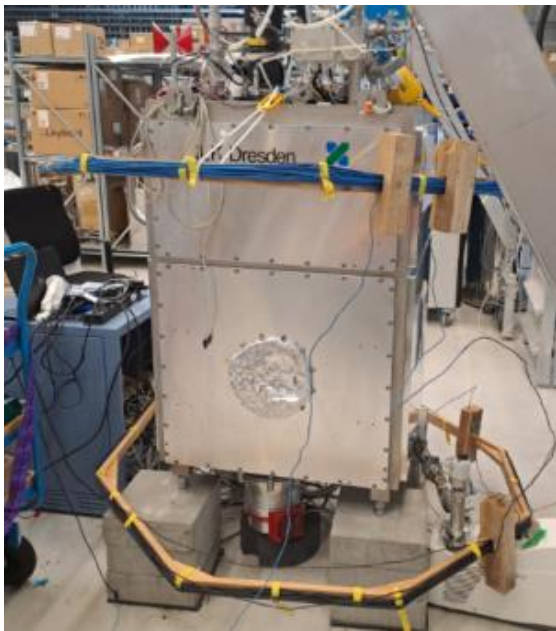

- **AXIAL CCC IN JENA :**
- The expected screening factor of the axial CCC is
- **200 dB**
- It's a value that can't be measured in the laboratory
- It was possible to generate the 1 mT field and the axial coreless CCC it's not able to detect any signal
- This means that the screening factor is much bigger and is enough to say that the axial geometry of the CCC is able to provide an effective shielding
- The axial CCC is than not sensitive to external magnetic field

# Test of axial CCC in GSI cryostat

- The next step is installing the Axial CCC in the beam line cryostat in GSI
- The two cryostats are completely different, one of the main differences is the beam tube going through the CCC itself, as it is possible to see on this picture taken during installation

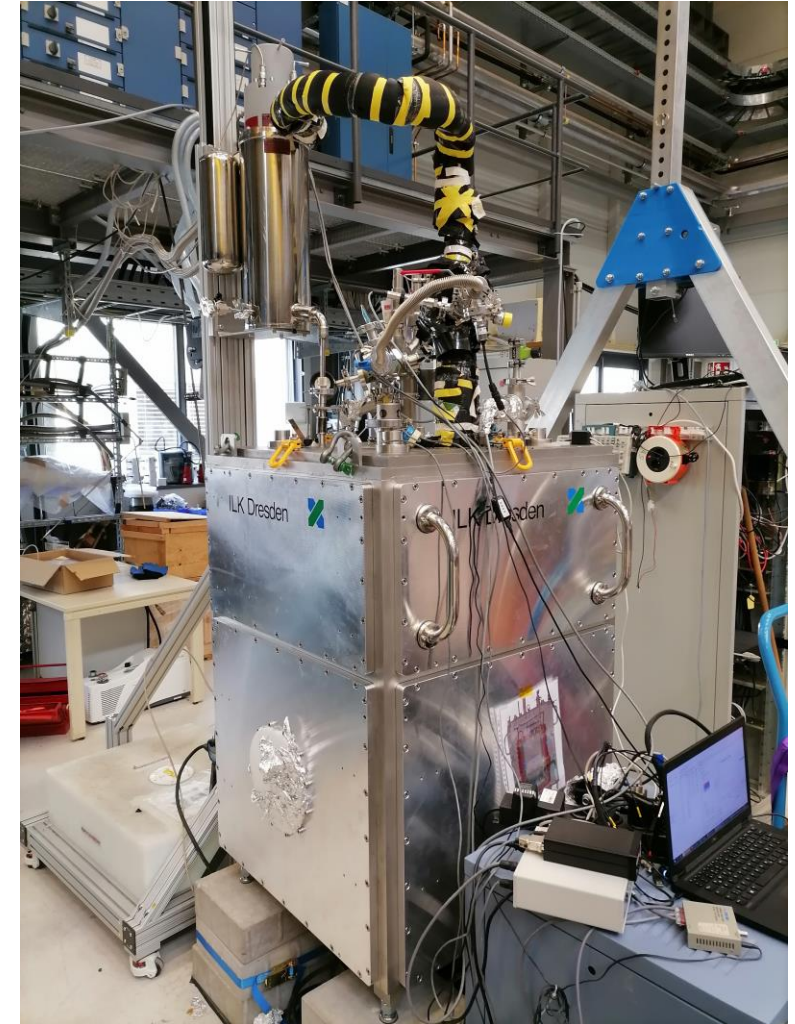



# SQUID characteristics

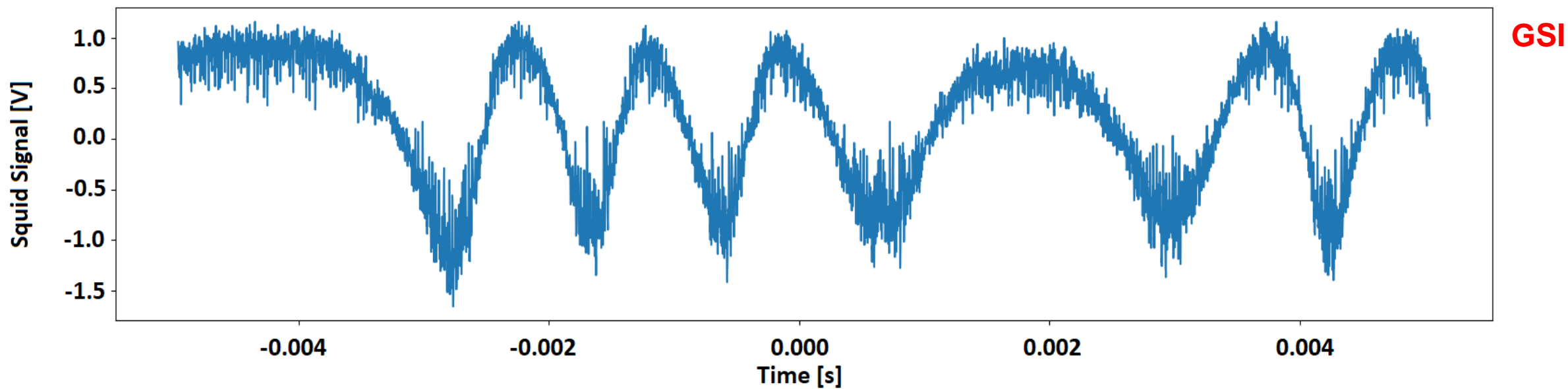
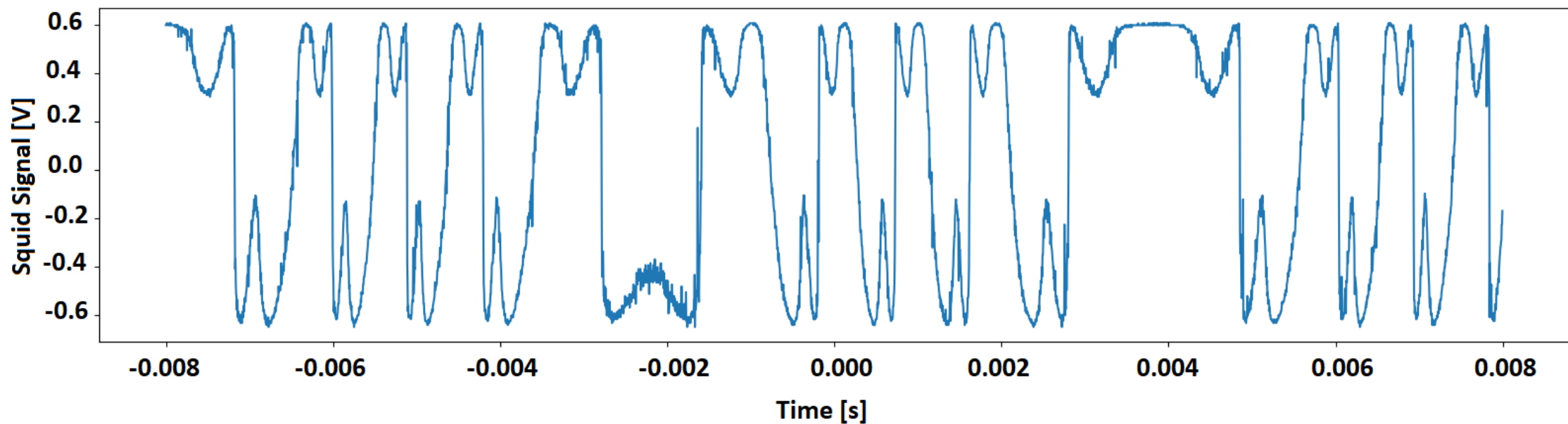

- The noise in GSI is almost 50 times higher than the noise in Jena, and it's so big that the SQUID is not able to find a stable working point, so it can't be used to detect any signal
- It was possible to use the low sensitive squid to estimate the level of the noise floor, that is around  $2 \mu\text{A}$ , too high to allow the use of the axial coreless CCC to detect any signal
- Even if the axial coreless CCC can't be used to detect any signal the test has shown the validity of the axial geometry to improve the magnetic screening of the detector
- It has also shown the effectiveness of a cascade squid system to improve the slew rate of the detector
- This has suggested an improvement of the CCC that allow to exploit the positive sides of the two geometries: Axial Double Core CCC

# Axial Double Core CCC (DCCC)

- The Axial double core CCC (DCCC) will use the axial meander structure to provide a high magnetic screening factor
- The use of the Core will strongly improve the coupling of the beam with the SQUIDS
- The use of two cores, connected to two different SQUIDS, allows to reduce the effect of the thermal Barkausen jumps, strongly reducing the low frequency noise
- The inductance of the core ask for the addition of a low pass filter on the system, decreasing the intensity of high frequency noises
- The DCCC will use a similar cascade squid system as the one used for the axial coreless CCC, to improve the slew rate
- The DCCC is based on the CCC-sm-series, developed by FSU jena:

V. Tympel, et al., "Creation of the first high-inductance sensor of the CCC-Sm series." IBIC'22, Krakow, Poland, Sept. 2022, doi:10.18429/JACoW-IBIC2022-WEP30

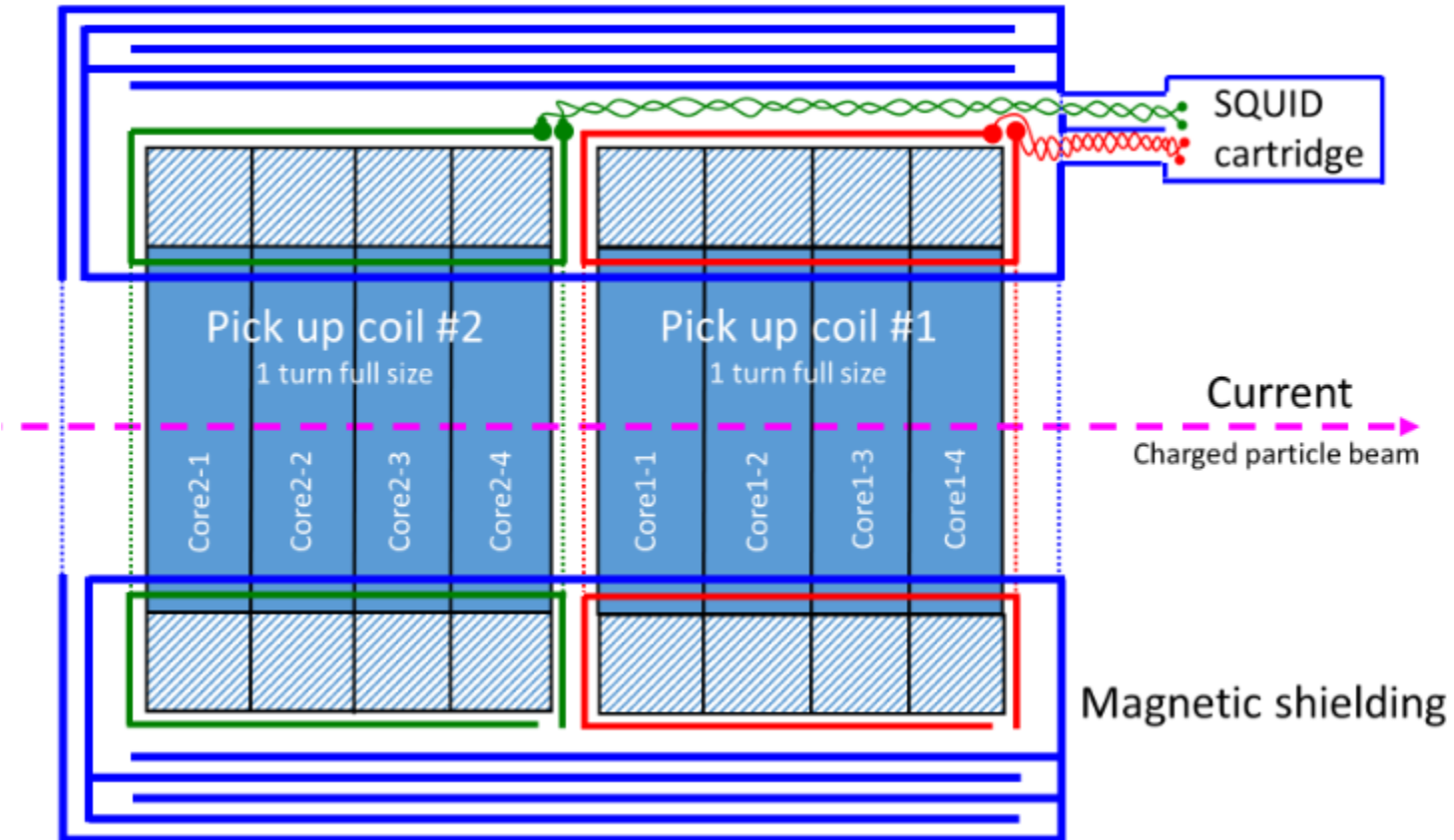



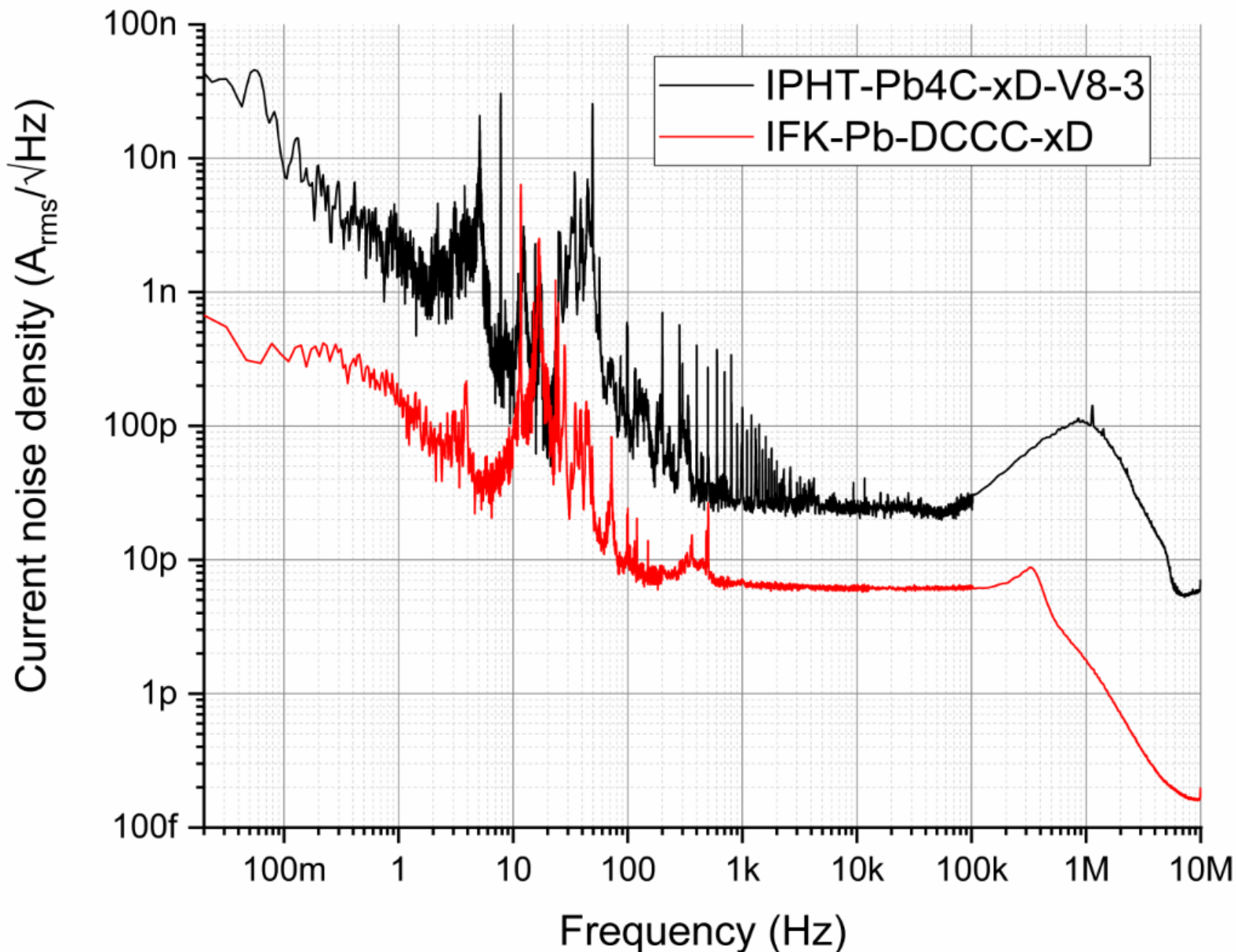

- A first prototype of the double core CCC has been tested in Jena
- In the plot it's shown the noise figure of the DCCC in red, and of the axial coreless CCC in black
- It's possible to see that the noise of the DCCC is much lower than the noise of the axial coreless CCC
- This plot is really promising for the DCCC, the noise of the new detector is comparable to the noise of the radial CCC that has been tested in the accelerator environment

- The CCC has been proved as a valid detector for low beam current measurements, with some limitations
- To improve the CCC performance we have tested the axial coreless prototype
- The axial geometry has shown to be really efficient to strongly improve the magnetic screening factor
- The cascade SQUID system has show to be very effective to improve the bandwidth and the slew rate of the detector
- The test of the CCC in GSI has shown that the axial coreless CCC can't be used to detect any signal in the accelerator environment, because the noise floor is too high
- Using the knowledge on the axial geometry we were able to design and develop the first prototype of the double core CCC, that it should be the definitive version of the CCC for FAIR

- In december the radial CCC will be tested in the transfer lines at GSI, to test it as it will be used in FAIR
- At the start of the next year the final prototype of the Double Core CCC will be tested in jena and then in the cryostat in GSI
- Together with the test of the new CCC also the new shield will be tested, to finalize the cryogenics side of the detector
- The Double core CCC will be tested afterwards on the transfer lines at GSI, allowing the definitive confrontation between the radial version and the double core CCC
- This will allow to finalize the best possible version of the CCC for FAIR



# Thanks a lot for the attention!

For additional info: [l.crescimbeni@gsi.de](mailto:l.crescimbeni@gsi.de)

**HI JENA**  
HELMHOLTZ  
Helmholtz-Institut Jena



Friedrich-  
Schiller-  
Universität



TECHNISCHE  
UNIVERSITÄT  
DARMSTADT



**ipht**   
LEIBNIZ-INSTITUT für  
PHOTONISCHE TECHNOLOGIEN

- The CCC calibration line is composed of a wire going through the CCC simulating the beam current, it's possible to provide to the CCC waveform of defined frequency, intensity and shape to simulate each possible beam
- In CRYRING this system has been used to calibrate the CCC and in particular to estimate, using “Dry Runs”, the effect of external perturbation on the CCC signal, identifying two main sources of systematic noise:

## Helium Liquifier

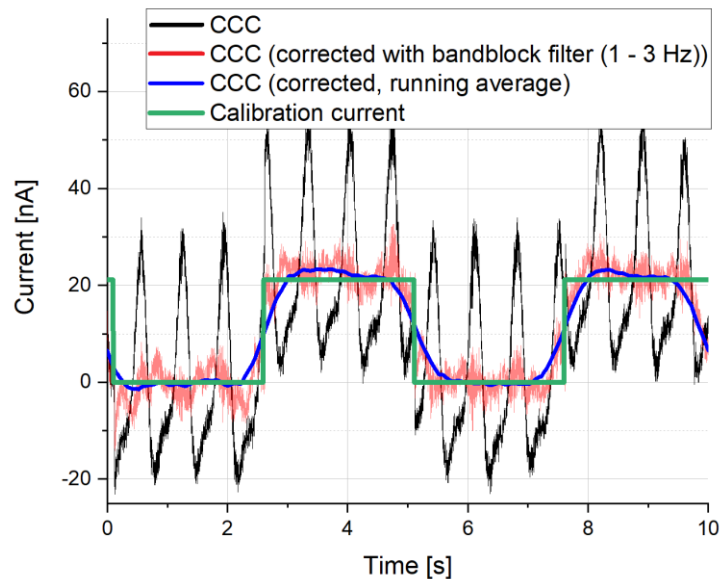

Periodic with 1.4 Hz frequency

## Dipole Ramp

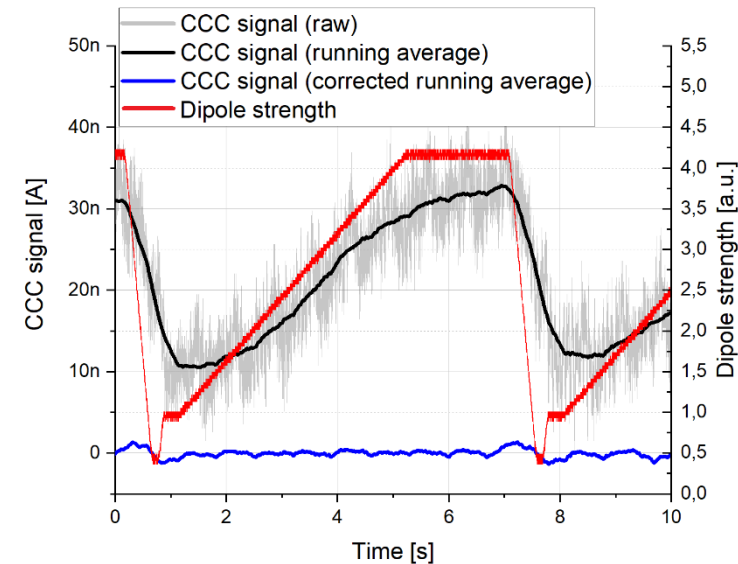

Deterministic, measured in “Dry Runs”

- It's then possible to develop software filters that allows to remove the two main sources of systematic noise from the data collected, removing the two main sources of systematic noise from the CCC measurement