

Integration of vertex detector services and cooling

Gherardo Ammirabile¹

Daniele Benvenuti¹, Manuela Boscolo², Filippo Bosi¹, Andrea Ciarma², Francesco Franesini², Stefano Lauciani², Maurizio Massa¹, Andrea Moggi¹, Fabrizio Palla¹

¹ INFN Sezione di Pisa, Italy

² INFN Laboratori Nazionali di Frascati (RM), Italy

11th FCC Week
Vienna (Austria)
19-23 May 2025

INTRODUCTION

- **Current vertex layout**
- **Services of vertex:**
 - **Inner vertex: air cooling and cables**
 - **Middle/Outer vertex and discs: water cooling and cables**
 - **Beam pipe cooling**
- **Constraints and requirements:**
 - **Limit the LumiCal material budget below 130 mrad**
 - **Minimize the material budget for the vertex and the drift chamber**
 - **Facilitate assembly, opening and maintenance operations**

Current vertex layout

Outer vertex tracker: ATLASPix3 based

- Modules of $50 \times 150 \mu\text{m}^2$ pixel size
- Intermediate barrel at 13 cm radius
 - Outer barrel at 31.5 cm radius
 - 3 discs per side

Inner Vertex detector: ARCADIA based

- Modules of $25 \times 25 \mu\text{m}^2$ pixel size
- 3 barrel layers at
- 13.7, 23.7 and 34/35.6 mm radius

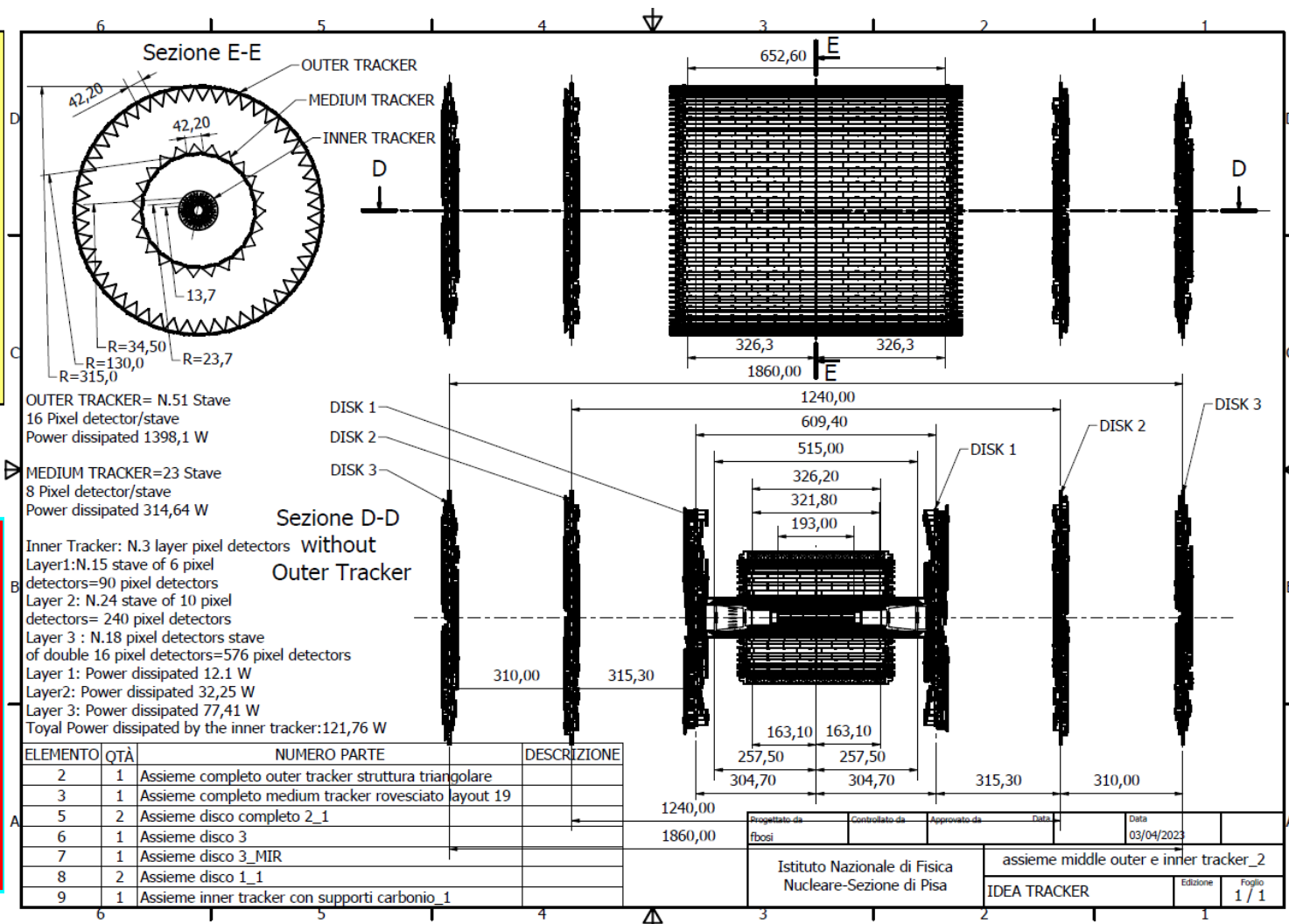

Inner vertex

Layer 1:

15 staves of 6 modules each
Power budget ≈ 12 W

Layer 2:

24 staves of 10 modules each
Power budget ≈ 32 W

Layer 3:

36 staves of 16 modules each
Power budget ≈ 77 W

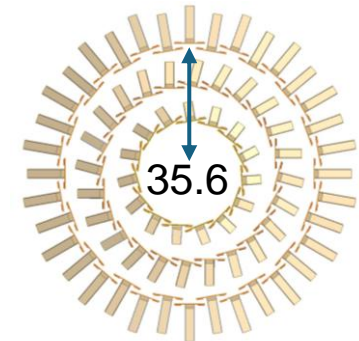
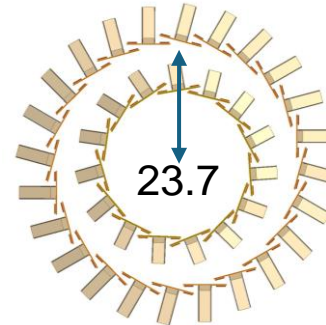
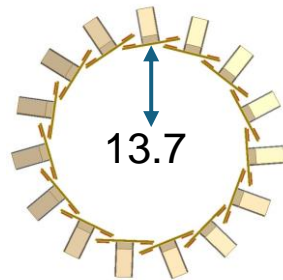
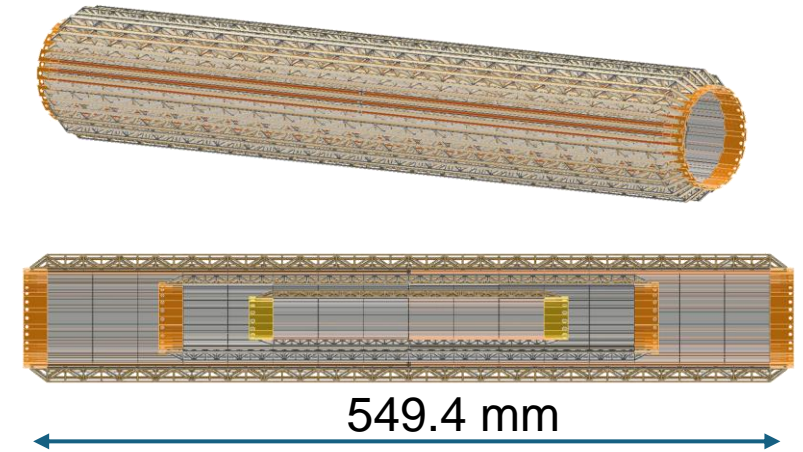
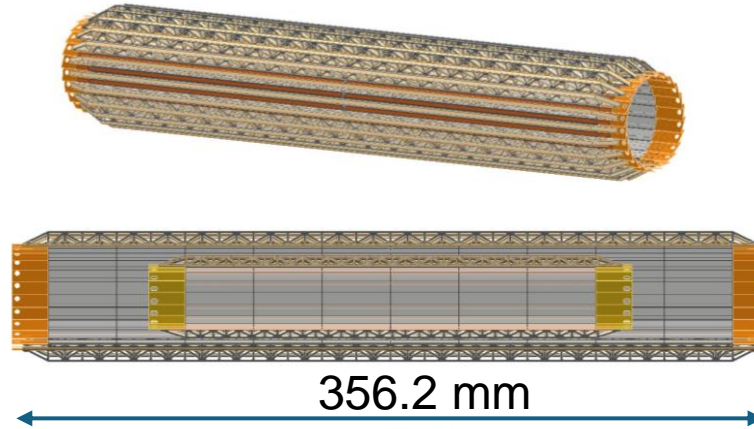
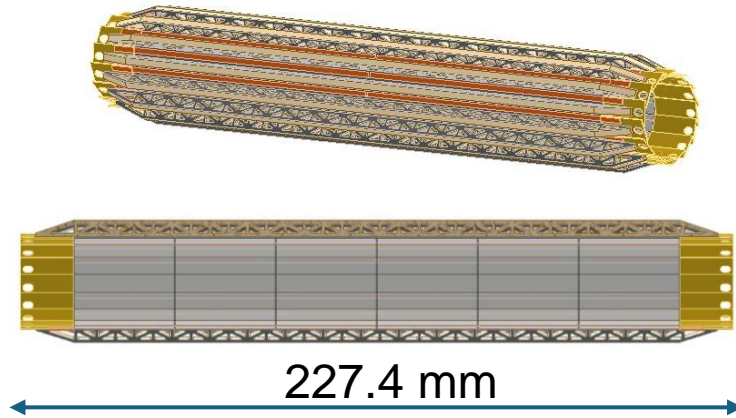

Reticular lightweight support to provide stiffness:

- Thin carbon fiber walls interleaved with Rohacell
- 2 buses (data and power) 1.8 mm wide and 250 μ m thick

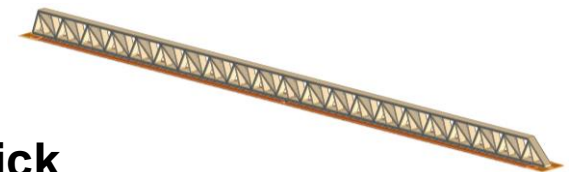

A
I
R

I
N
L
E
T

S
U
P
P
O
R
T

A
I
R

O
U
T
L
E
T

S
U
P
P
O
R
T

Air cooling system to keep at a stable and uniform manageable temperature the silicon detectors

3D printed support with integrated air ducts (High Temp Resin)

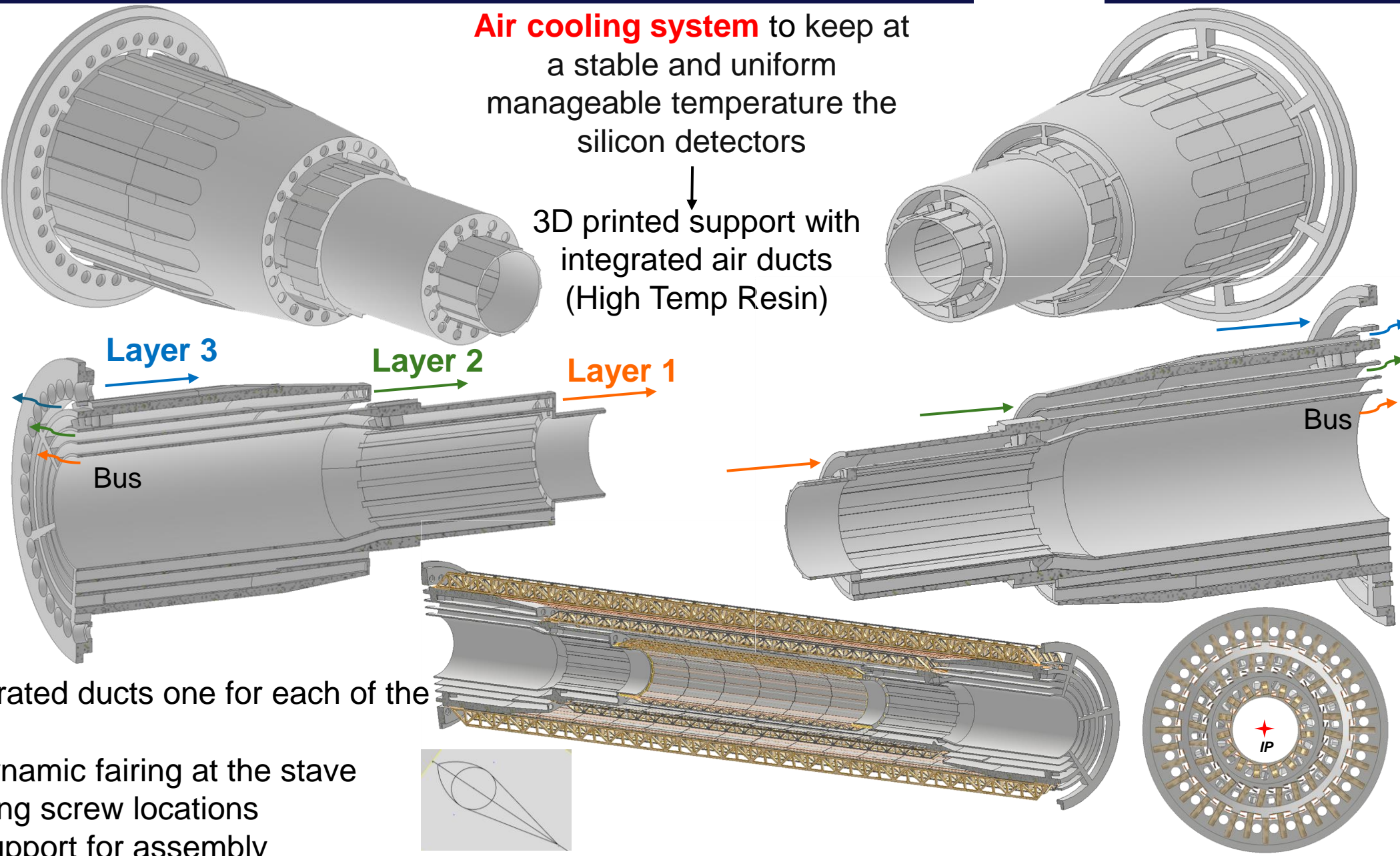

- 3 separated ducts one for each of the layers
- Aerodynamic fairing at the stave mounting screw locations
- Split support for assembly

Front view

Next step: how to join supports with integrated ducts to the air supply and outlet

Two different solutions

1. **Axial** inlet/outlet of air ducts

2. **Radial** inlet/outlet of air ducts

Conical support structure to allow connection to the inner vertex

System of pipes attached to the support tube

Choice based on physical and mechanical constraints

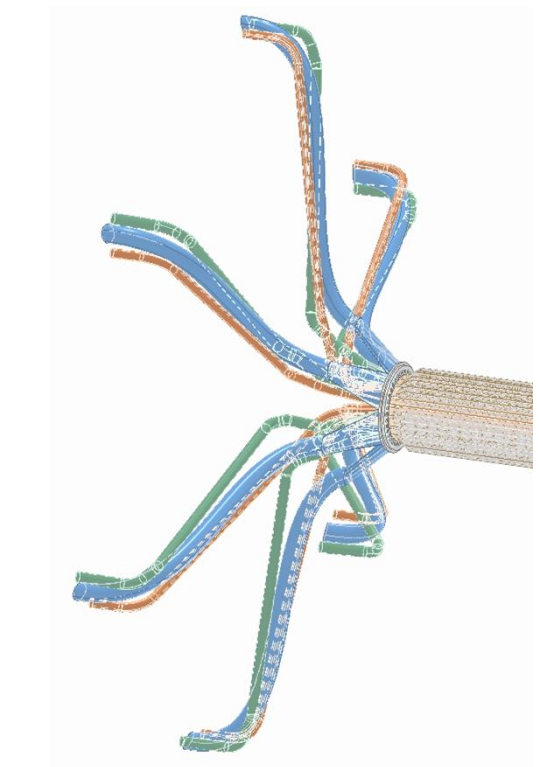
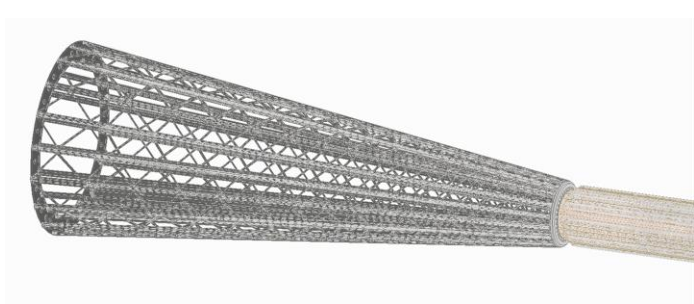

1. Axial inlet/outlet

The conical structure, with the air ducts for the three layers inside, is fixed to the 3D printed support

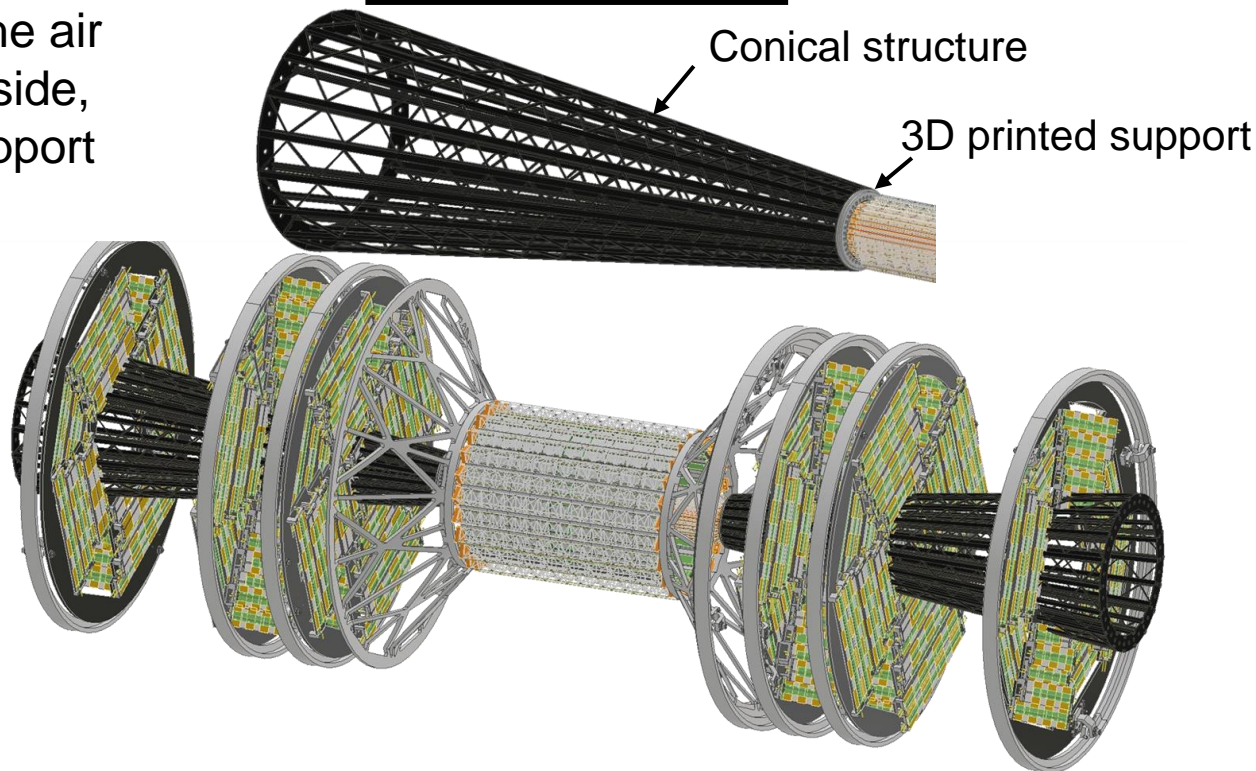

In the assembly, attention needs to be paid to

1. Physics:

- Projective geometry
- Particles could follow the direction of the cones
- Passive material in front of the LumiCal and discs

2. Integration/Maintenance:

- Need to split the discs
- Uneasy in opening the detector
- Connection of the cones to the beam pipe and to air ducts at the end

Optimization of the shape still under study



Hyperbolic structure
(impact discs acceptance)

2. Radial inlet/outlet

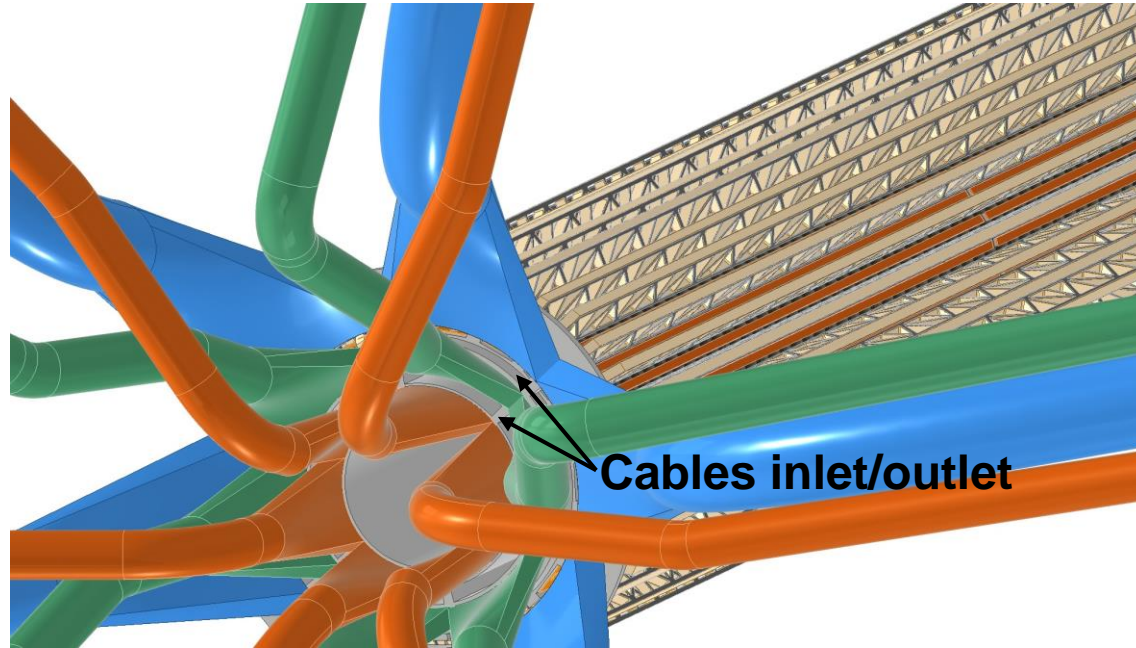

- Layer 3 ducts
- Layer 2 ducts
- Layer 1 ducts

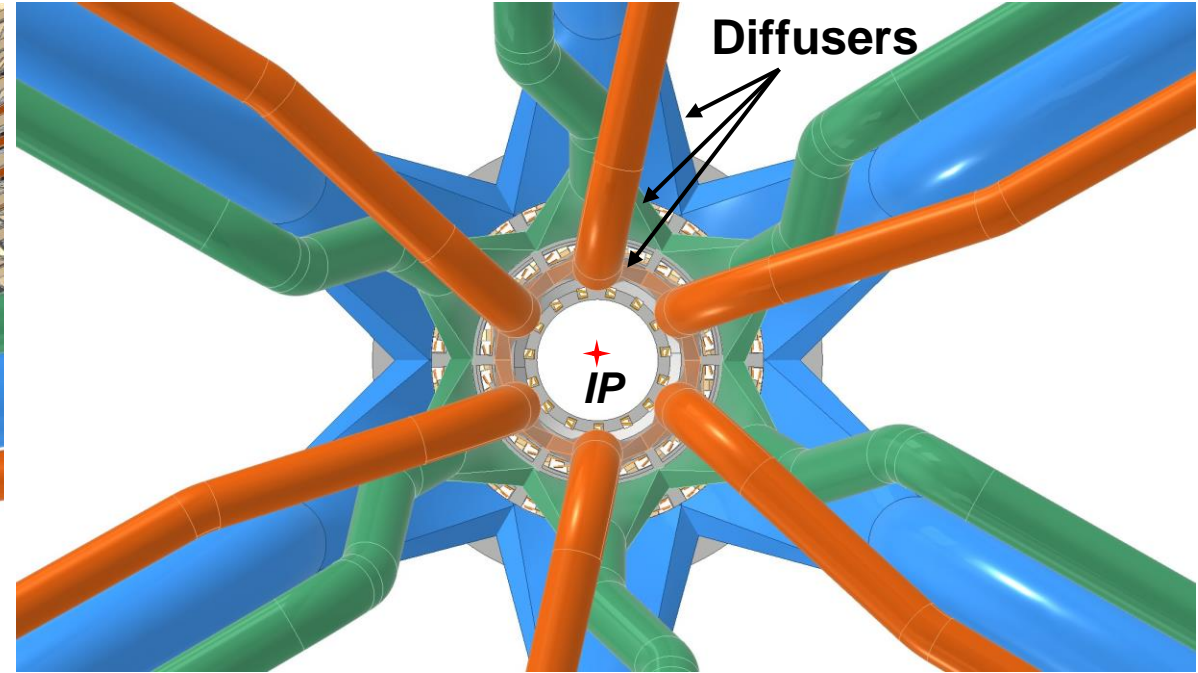

Rear view

6 sectors of 60° for each of the three independently powered layers



Diffusers included in the 3D printed support with hose connection



Need to be optimized in terms of length and pitch angle to allow for easy cables routing

2. Radial inlet/outlet

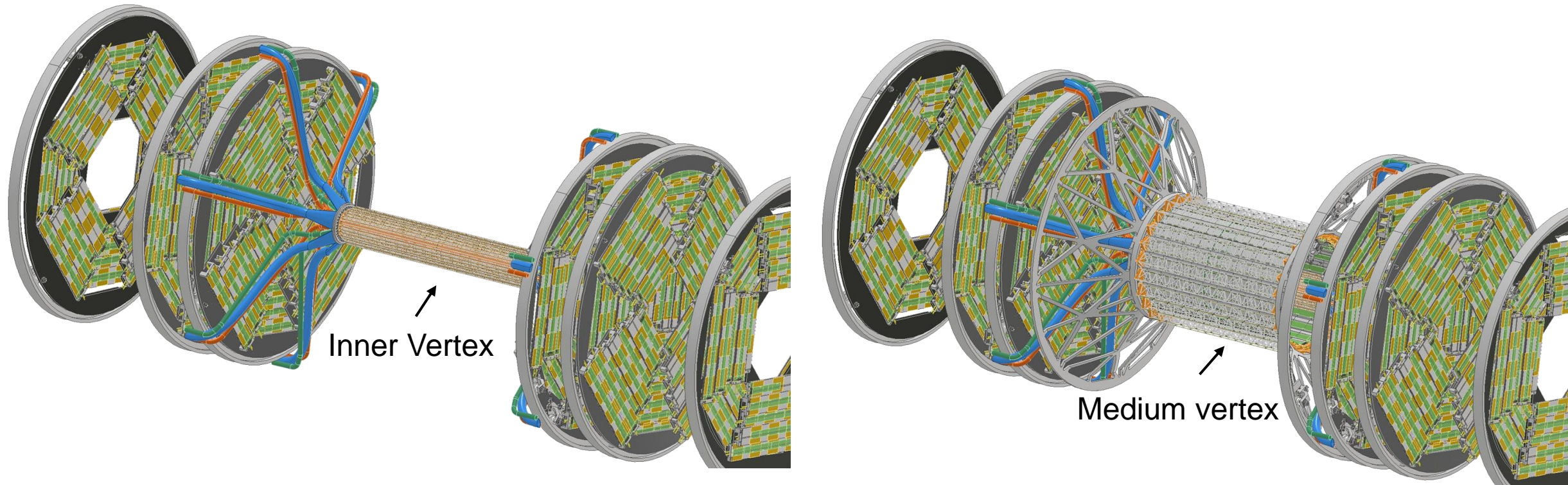

Pipe system that wraps around the innermost disk:

- Minimize the effect on the others
- Necessity of an adequate assembly procedure

Possible assembly procedure

1

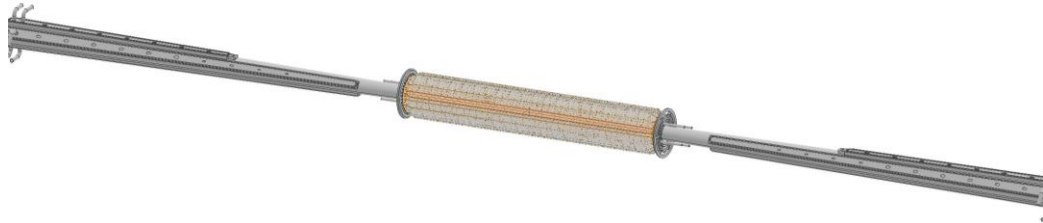

Beam pipe with inner vertex

2

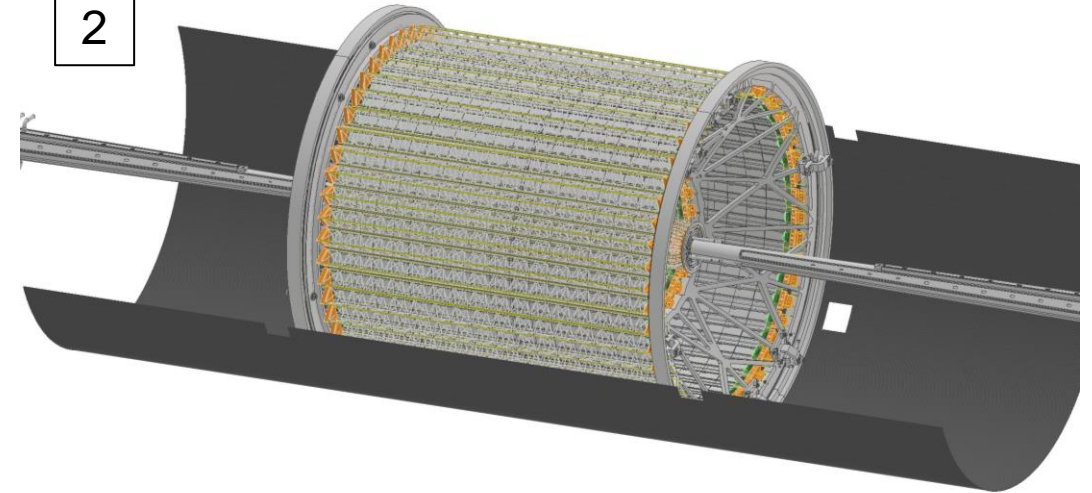

Medium and outer vertex assembly

3

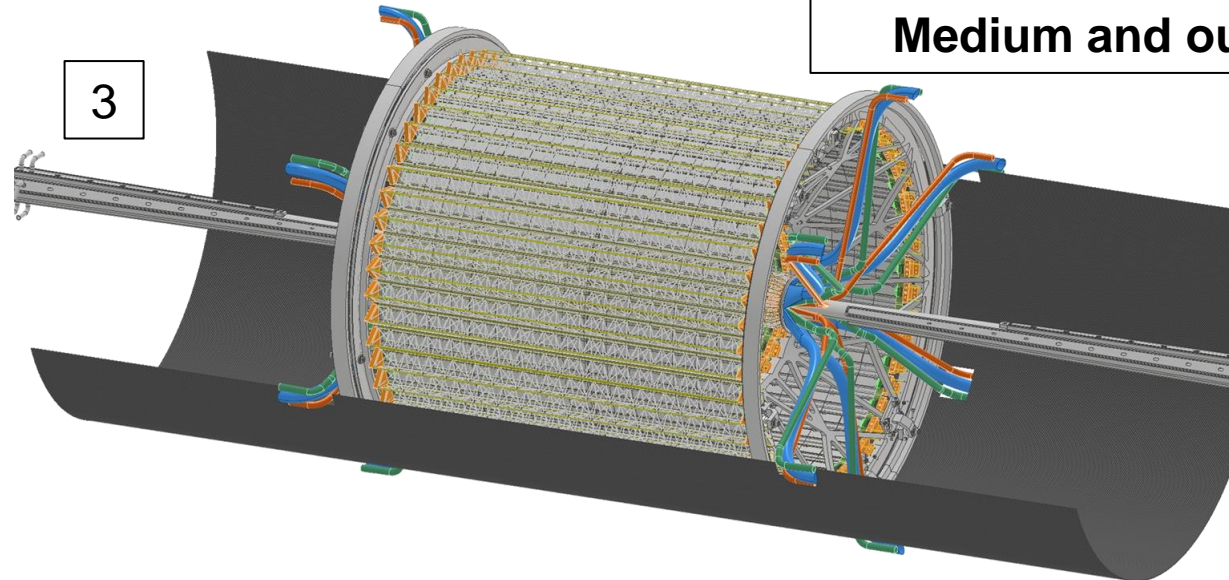

Inner vertex services assembly

- Layer 3 ducts
- Layer 2 ducts
- Layer 1 ducts

Possible assembly procedure

4

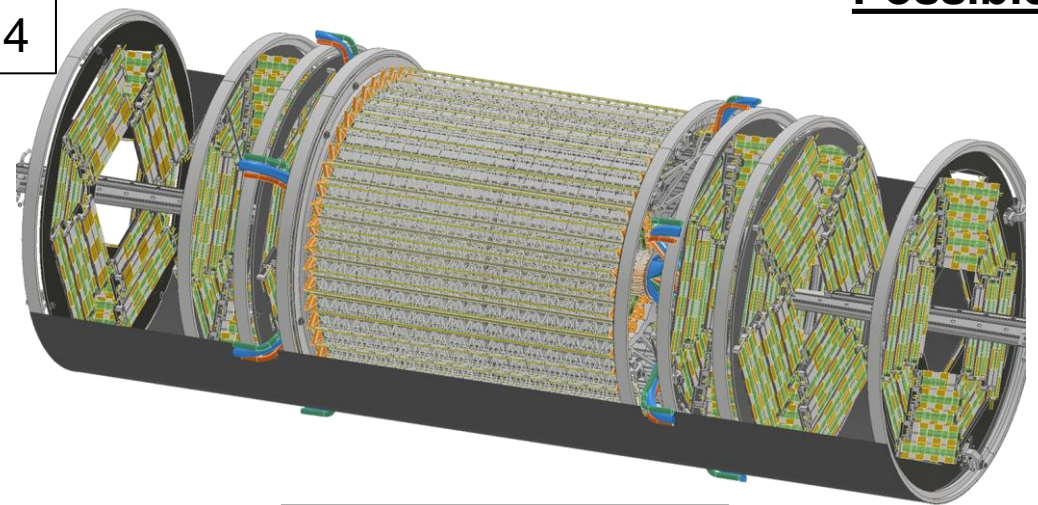

Discs assembly

- Layer 3 ducts
- Layer 2 ducts
- Layer 1 ducts

5

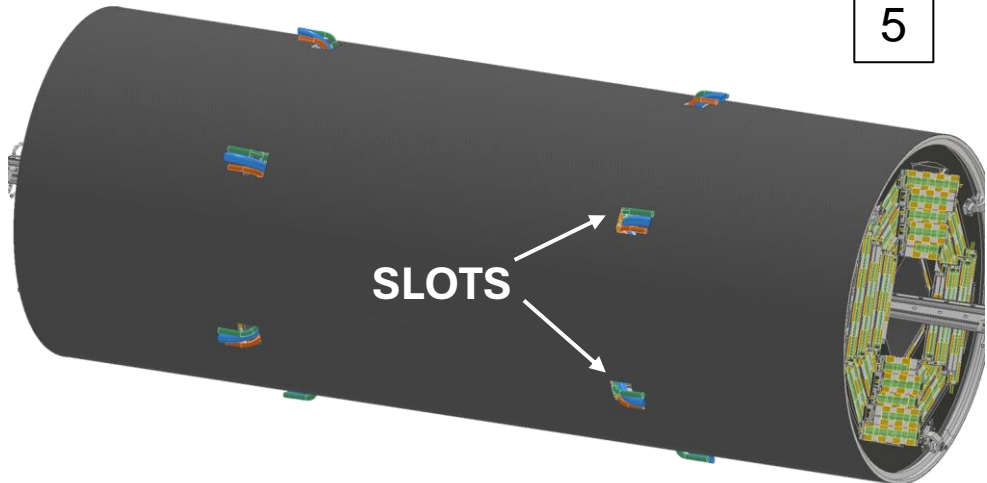

Support tube closure

Slots are required on the support tube to allow ducts entry and exit

The arrangement and shape of the slots must be studied to accomodate:

Air ducts of the three layers

Cooling water channels of discs, middle and outer barrels

Cables from the inner region

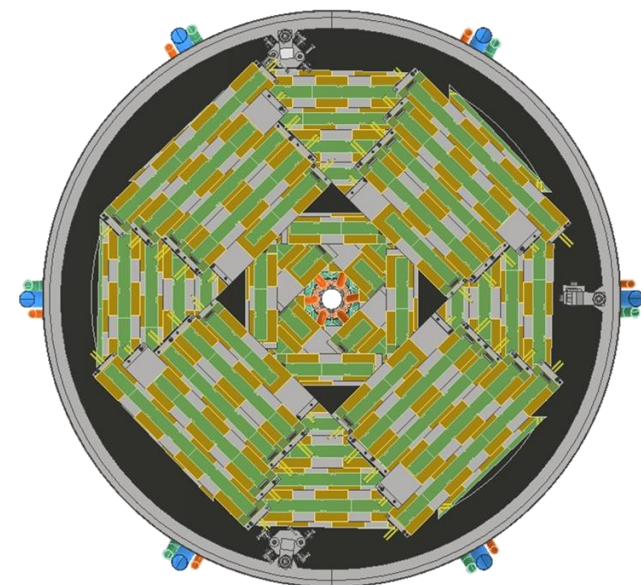

- ADVANTAGES:**
- Easier routing of services
 - Full Discs

Experimental setup to evaluate the effectiveness of air cooling

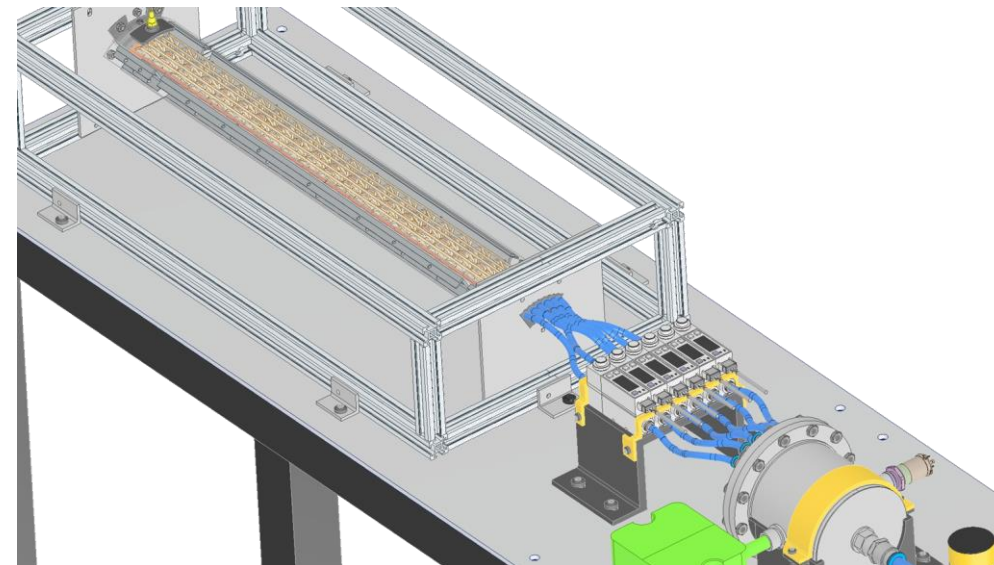
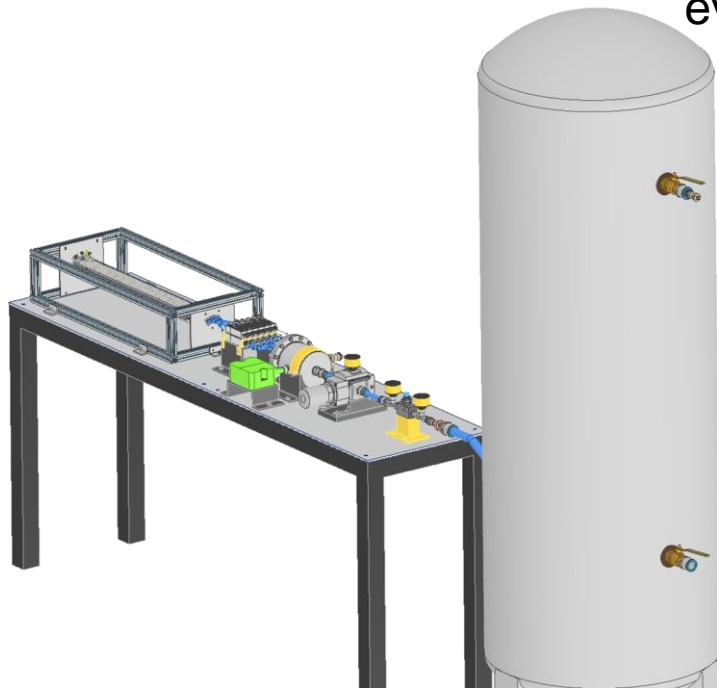

First test on a 60° circular sector of **layer 3** including five staves

Compressed air system to define:

- **Flow rate** needed to cool the detectors
- **Pressure drop** in the central region
- **Temperature increase** between inlet and outlet

In progress

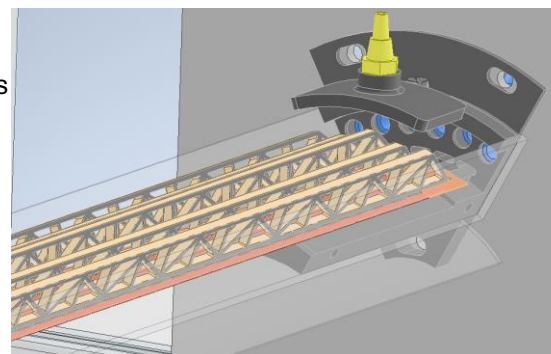

Next test on the same circular sector with all three layers



Compressed air system under installation in Pisa

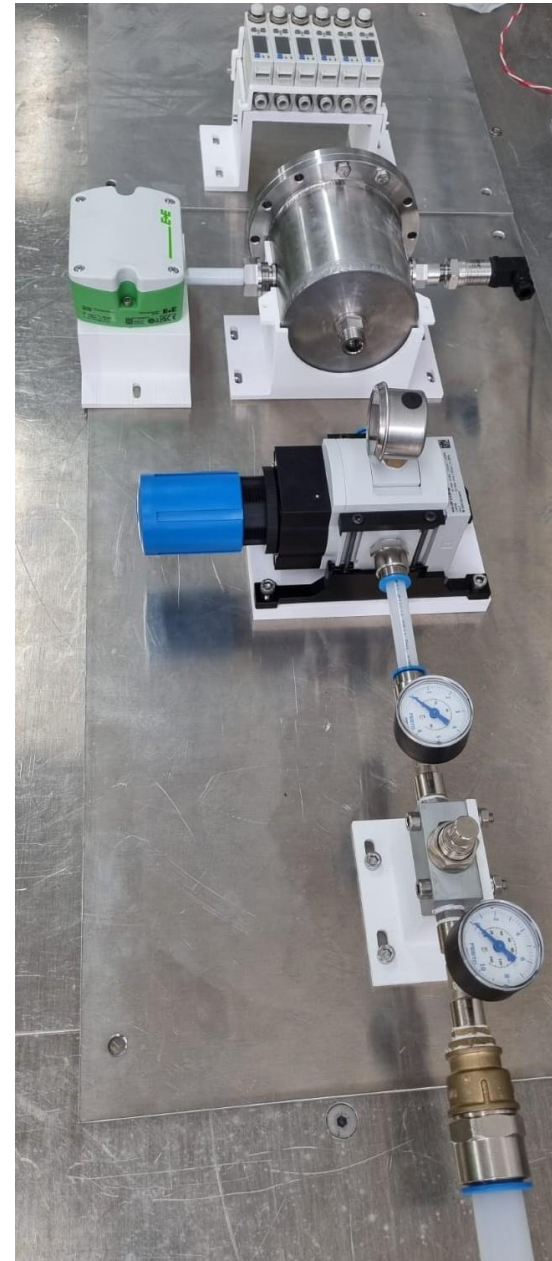

Designed to:

- Be **adaptable**
- Be **controlled**
- Allow **CFD result verification**

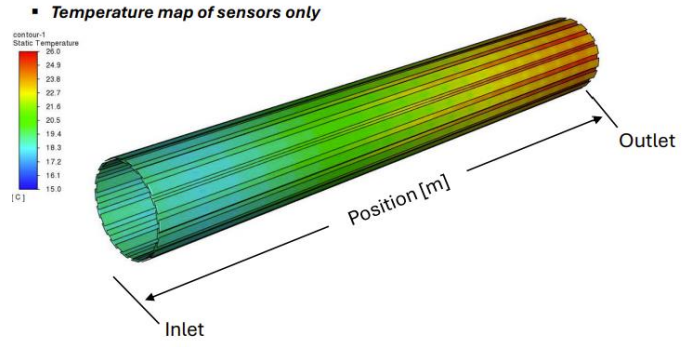

See 'Vertex Detector Cooling simulations',
Baldinelli, Turrioni

<https://indico.cern.ch/event/1439509/contributions/6289579/attachments/2995130/5276700/Baldinelli.pdf>

Beam pipe cooling

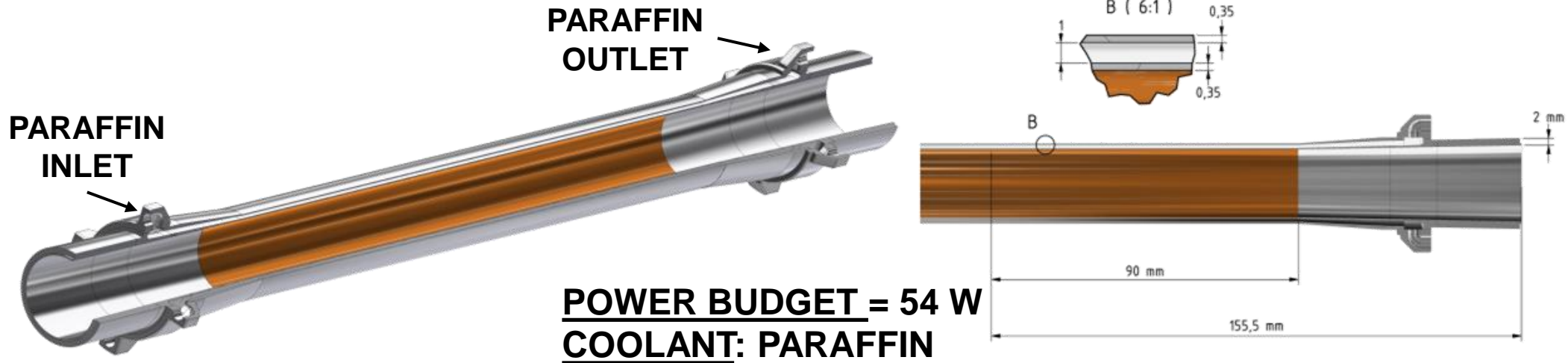

↓

Problems arise in the integration of liquid and air cooling systems

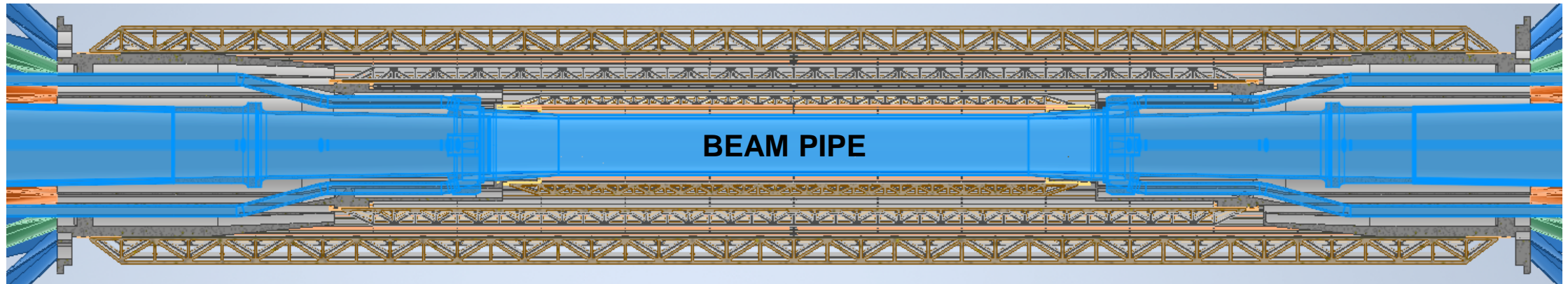

Cooling systems integration

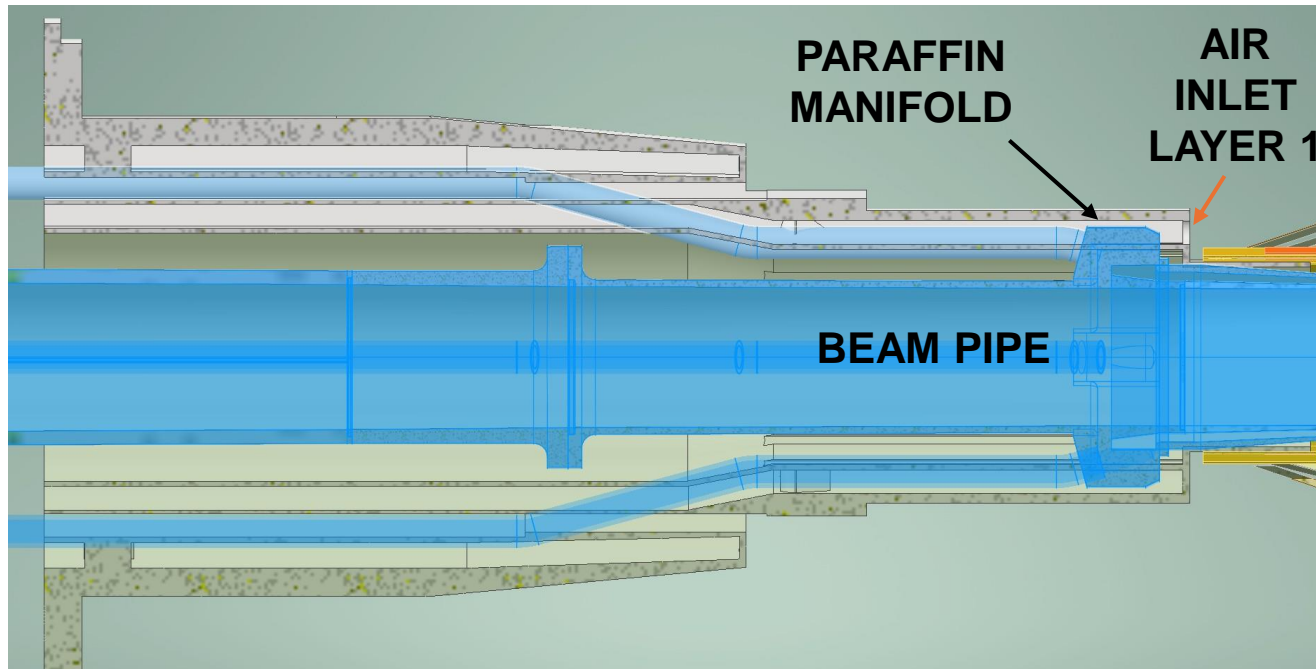

Paraffin manifolds reduce the layer 1 airflow and make it difficult to route the cables



Investigations are ongoing to move further away the paraffin manifolds

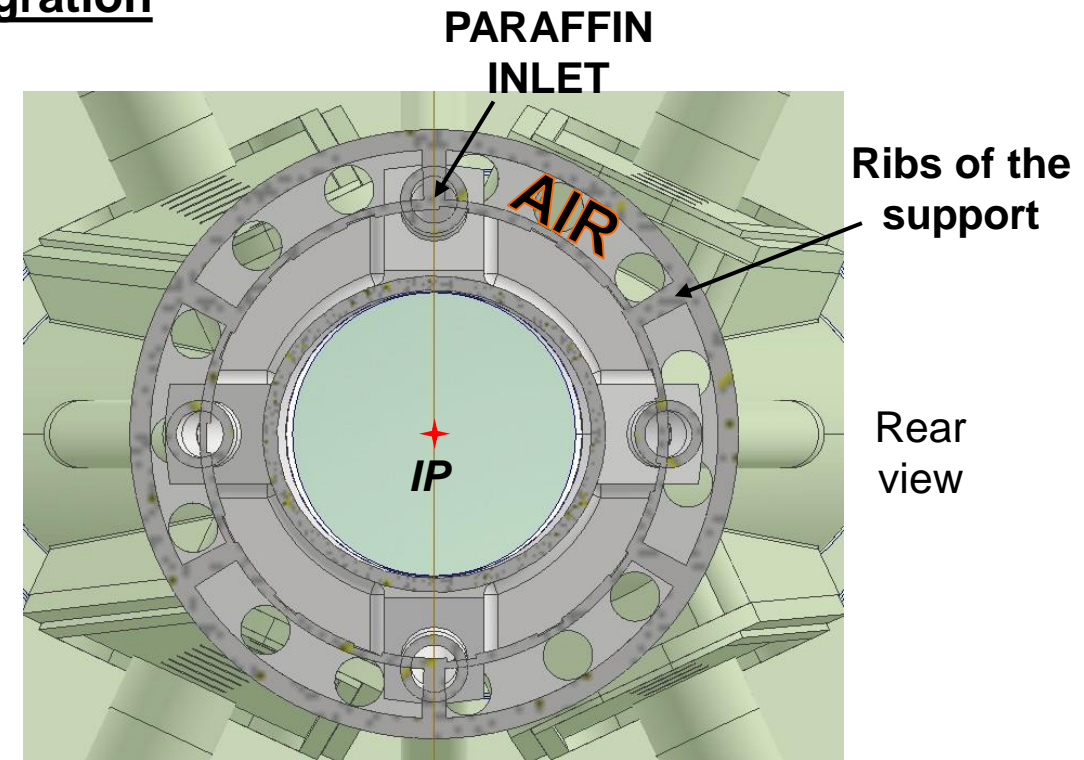

To allow the assembly of the 3D printed support, the paraffin ducts must be incorporated into the ribs of the support



Reduce the number of paraffin inlets from 4 to 3 arranged every 120°

Changing the paradigm of air cooling for layer 1

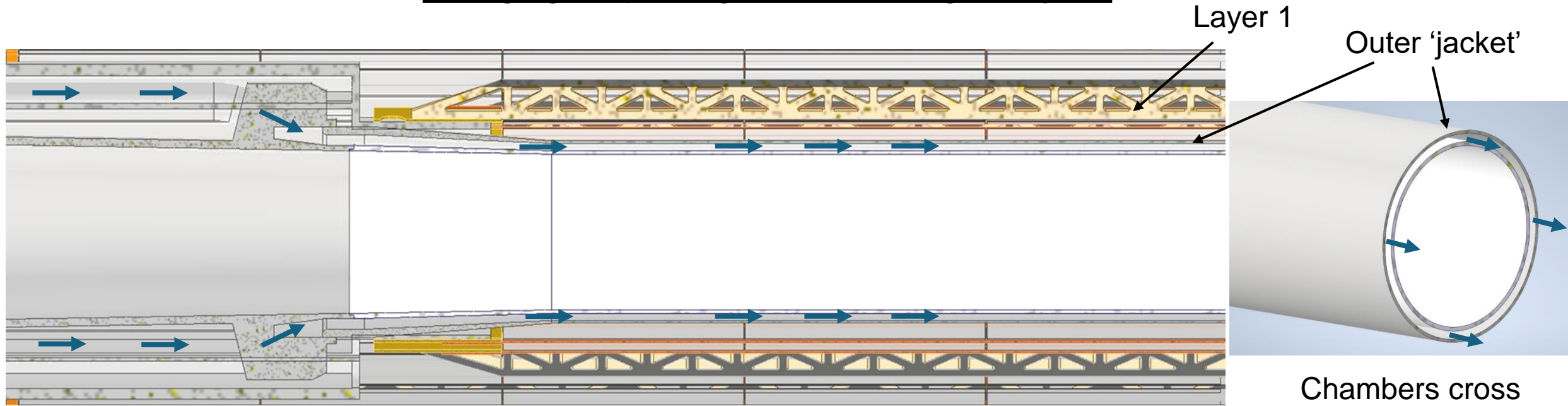

→ **PARAFFIN FLOW**

Layer 1 is only 2 mm away from the outer wall of the beam pipe



Why not to use the paraffin to cool the layer 1?



Needs an integrated design

Chambers cross section in AIBeMet

Air-cooled Layer 1

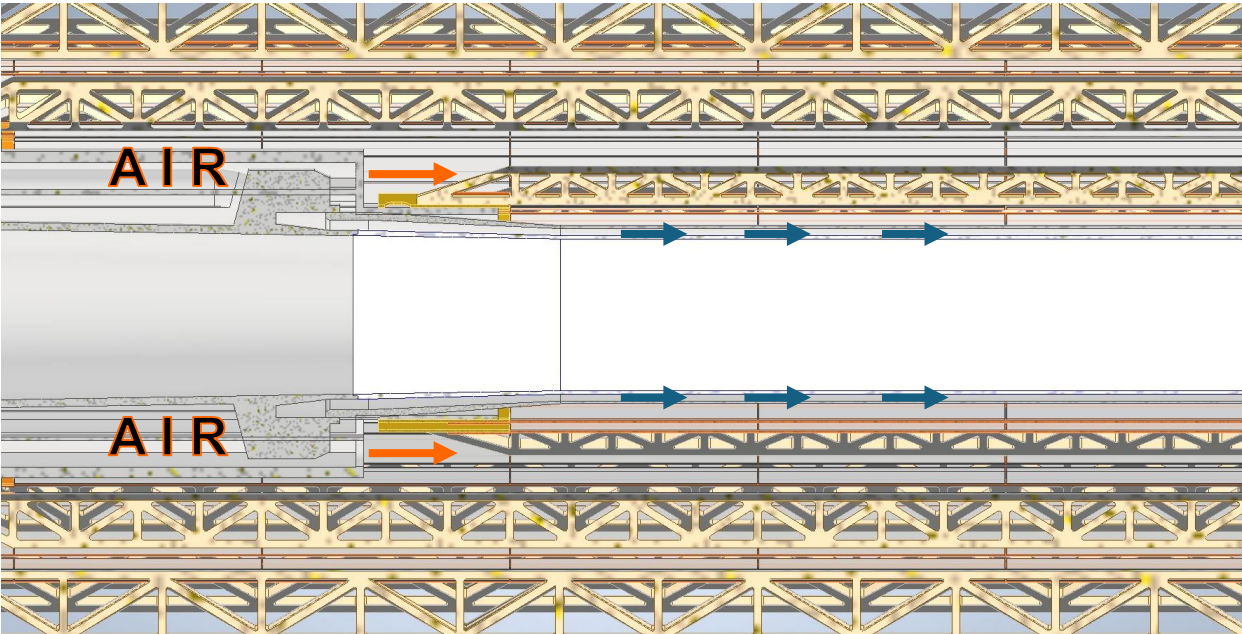

Integrated design

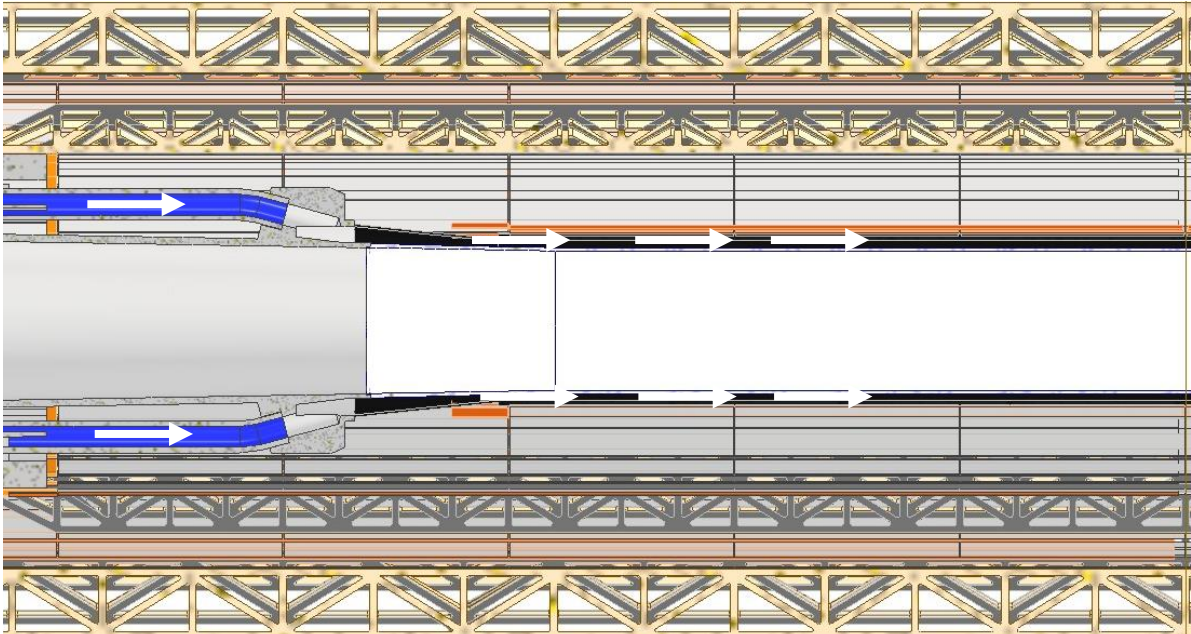

With the **integrated design** solution:

ADVANTAGES:

1. Layer 1 stiffeners are **eliminated**
2. Layer 1 air ducts are **eliminated**
3. Small additional heat load (12 W compatible with the paraffin system performance)
4. Layer 1 is 2 mm closer to the interaction point
5. Easier integration of cooling systems

Contact between the detectors and the outer jacket mediated by a layer of electrical insulator:

- Kapton
- Ceramics

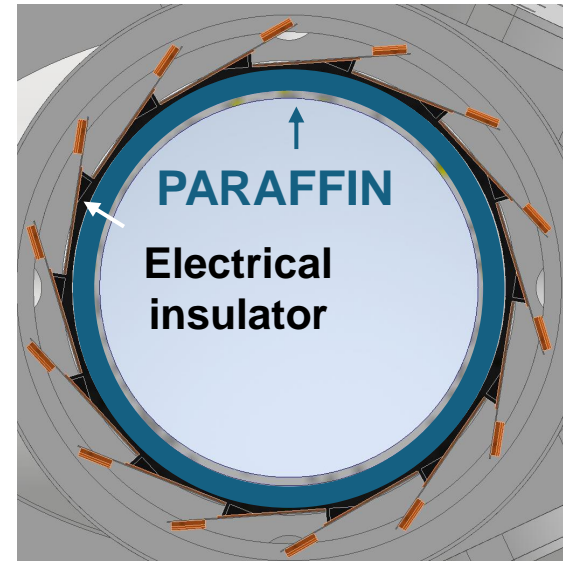

Need for a rigid support for the sensors:

- **Bonding**
- **Centering**
- **Assembly**

↓
Design under study

Integrated design

1. Allow the flow of paraffin inside
2. Support silicon detectors
3. Be thin to reduce the material budget

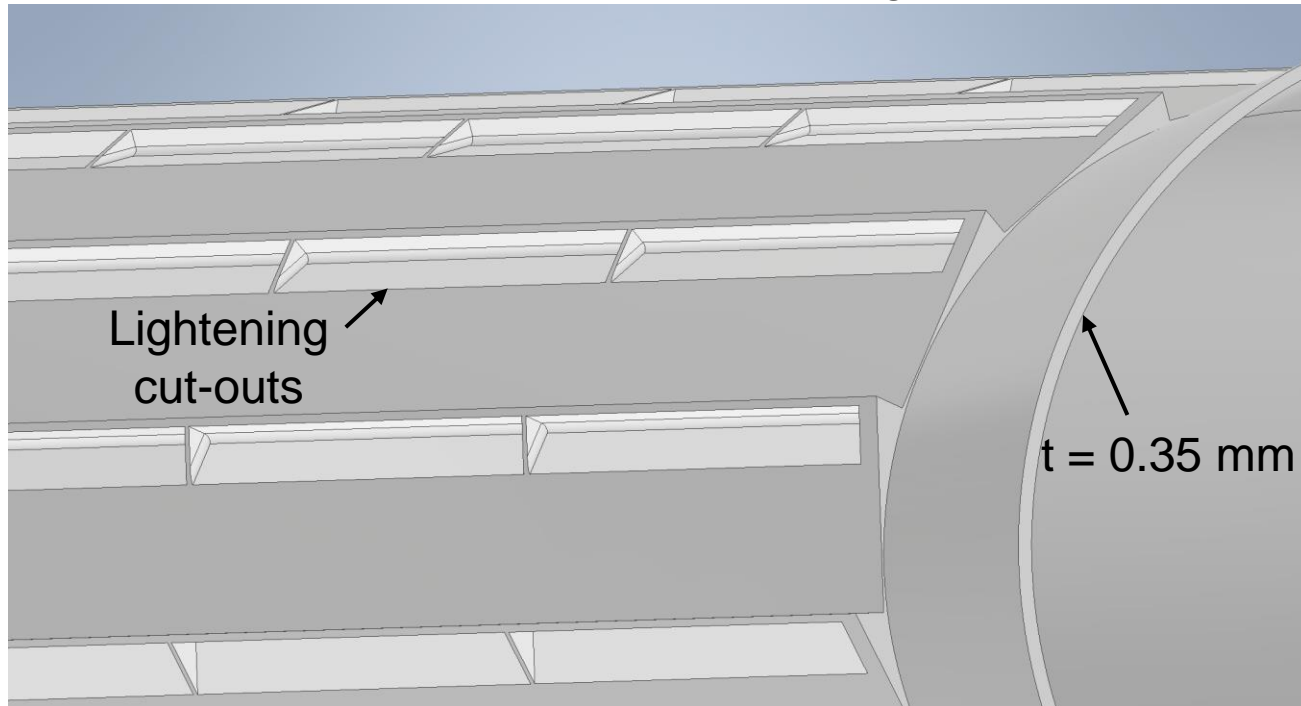

Conceptual design of the outer jacket

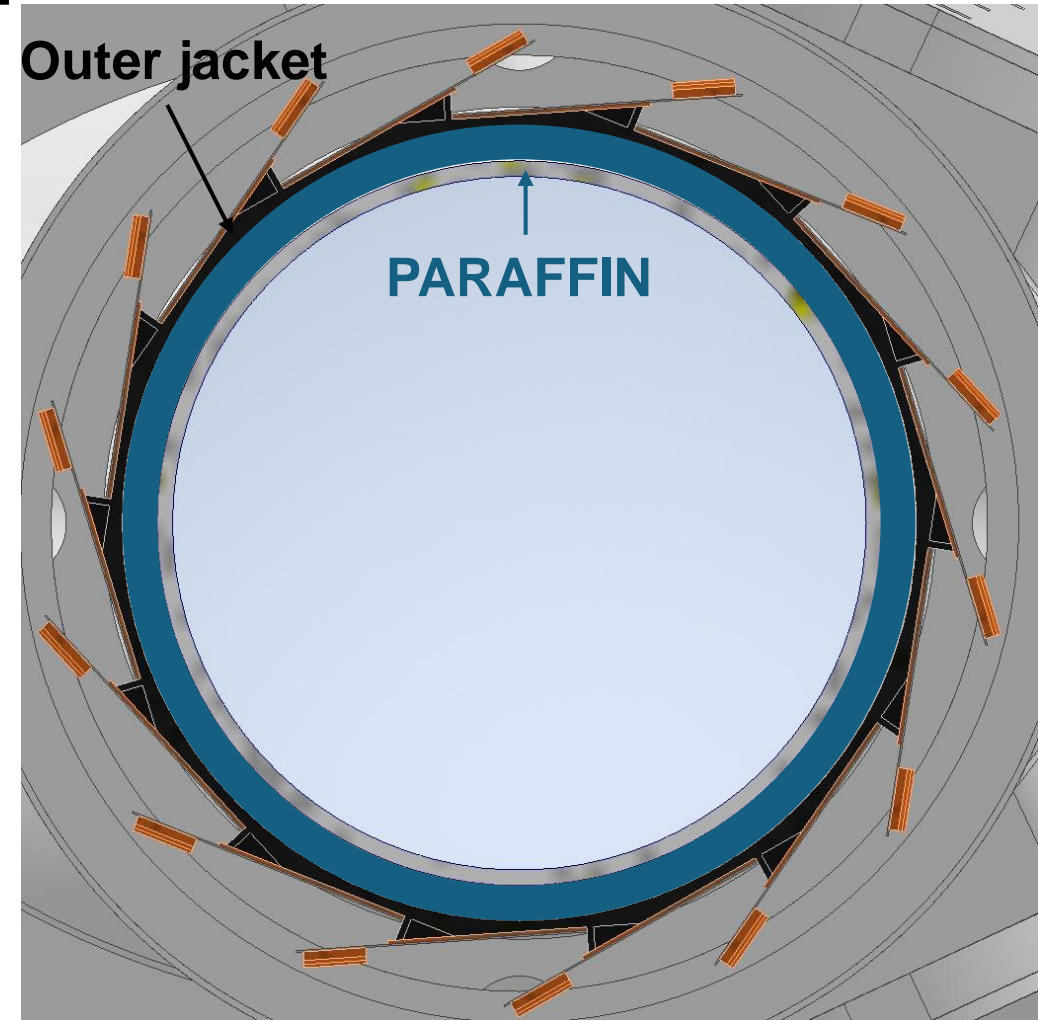
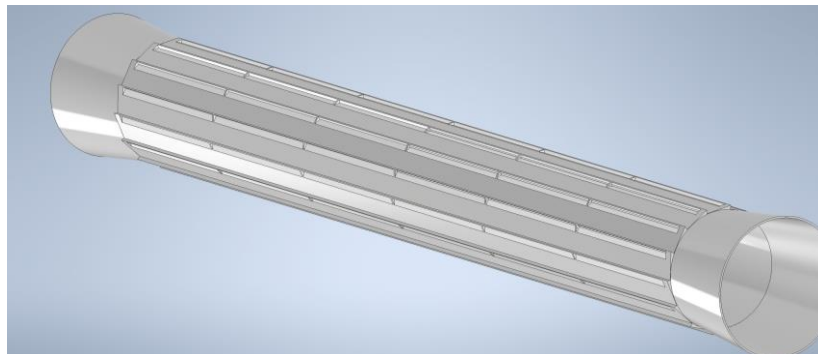

- Modules with sensors wire-bonded:
- On the r - ϕ side (ARCADIA like)
 - At the $\pm z$ ends (ALICE 3 like)

CONCLUSIONS:

The integration of the services of both the beam pipe and the detectors has posed challenges that are being resolved and that require some changes in the design.

The routing of the services seems to be feasible with the location of the large amount of cables and cooling ducts to the outside of the support cylinder.

The integrated cooling system of layer 1 allows for efficiency (fewer services needed) and brings it closer to the beam pipe.

The experimental tests will provide important indications on which solution is worth exploring further

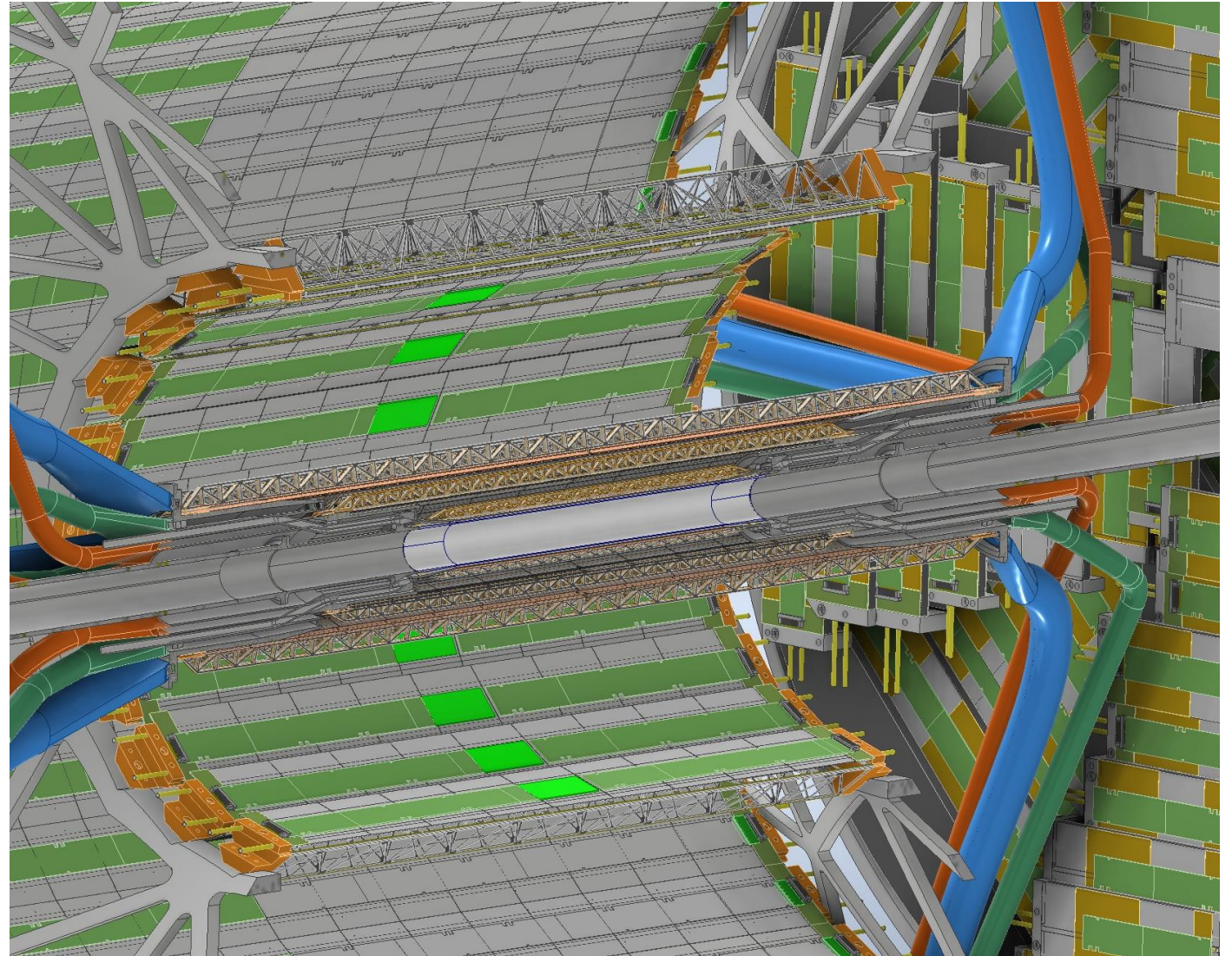



Thank you for your attention!