

# STATUS REPORT ON THE MDI ALIGNMENT MONITORING STUDY

Léonard WATRELOT

CERN BE-GM-FP

Many thanks to :

Manuela Boscolo, Francesco Franesini, Hélène Mainaud Durand, Mateusz Sosin, Michel Noir, Leo Sjoberg, Bartłomiej Pudło, Jürgen Gutekunst, Okan Dag

## Overview

- Quick reminder
- External monitoring system
- Deformation monitoring system
- MDI alignment Mock up
- Detector geometry monitoring

# Reminder of the FCC-ee MDI region

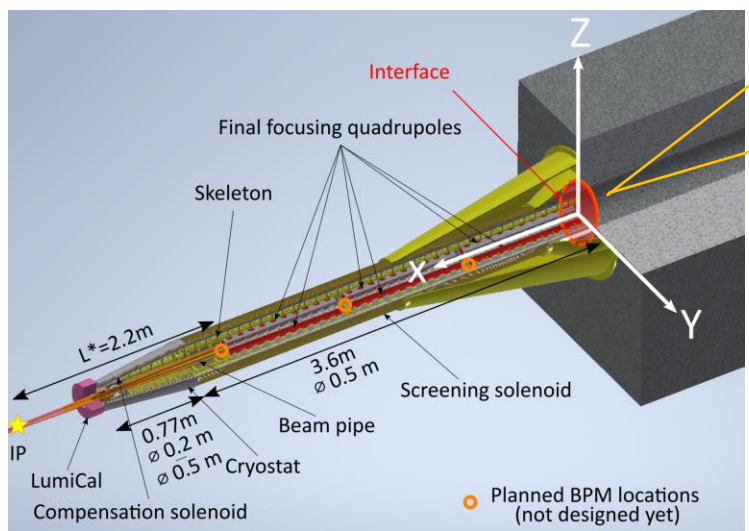
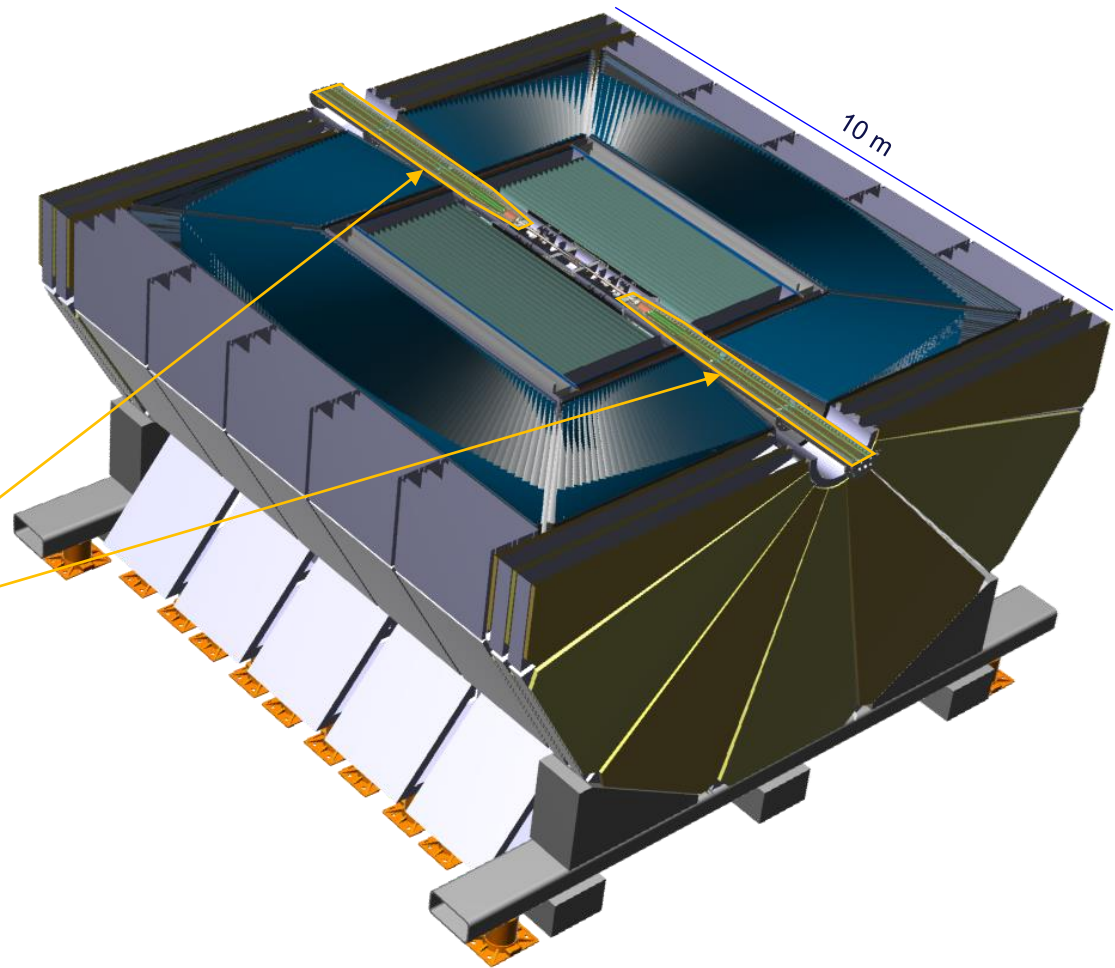
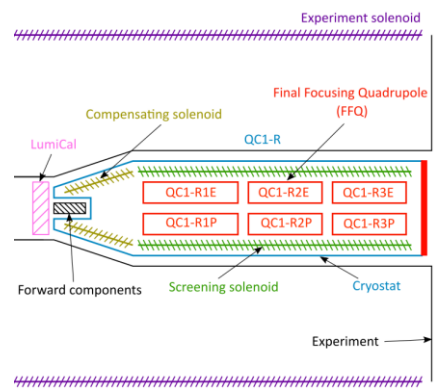

Alignment goal in the FCC-ee MDI: monitor the alignment of final focusing quadrupoles across the MDI

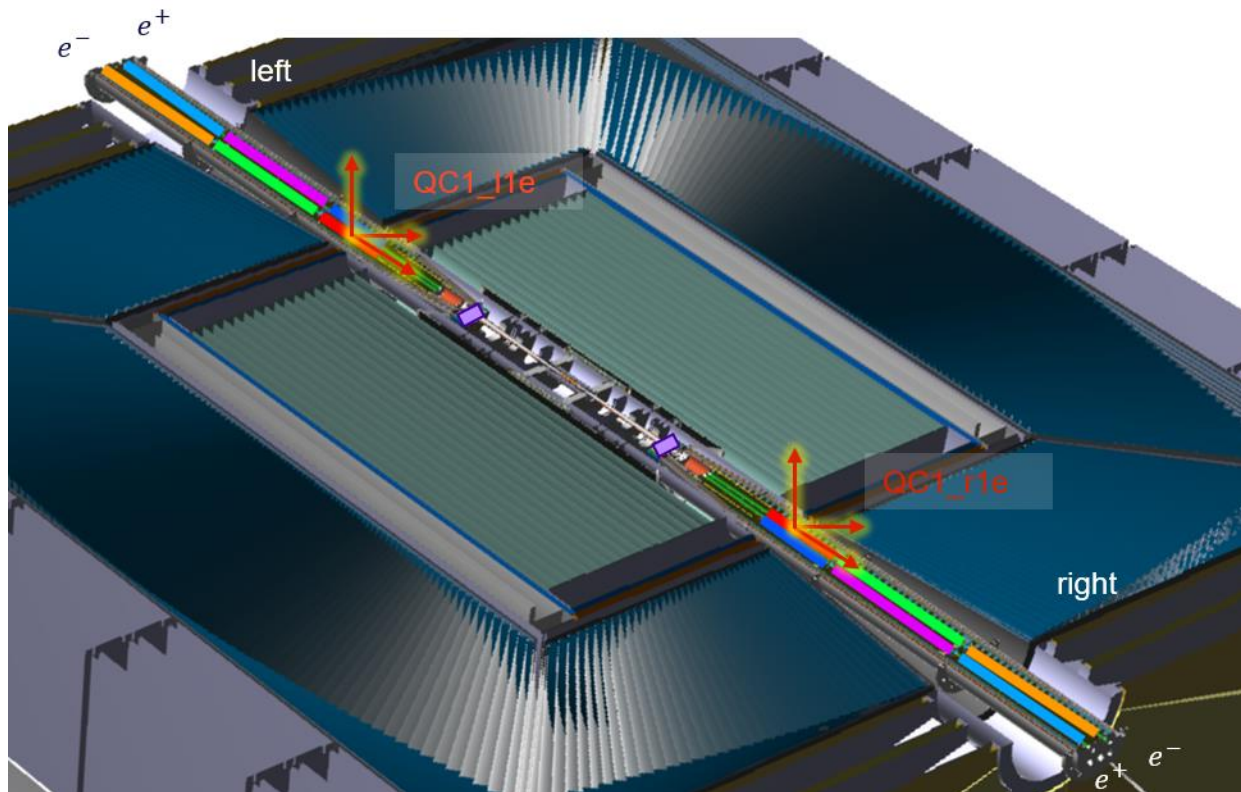

Sub-goal: first monitor the alignment of each side independently

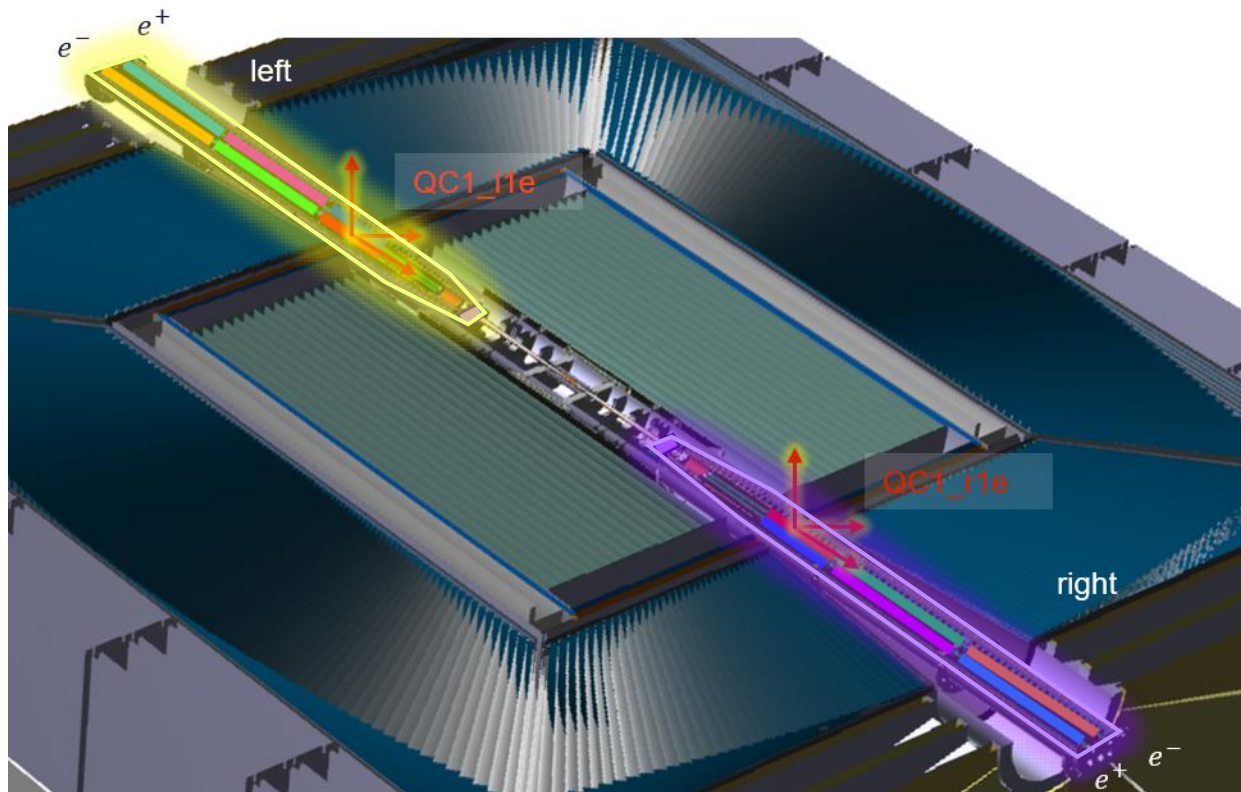

Sub-goal: recover the data out of the interface at the end of the assembly

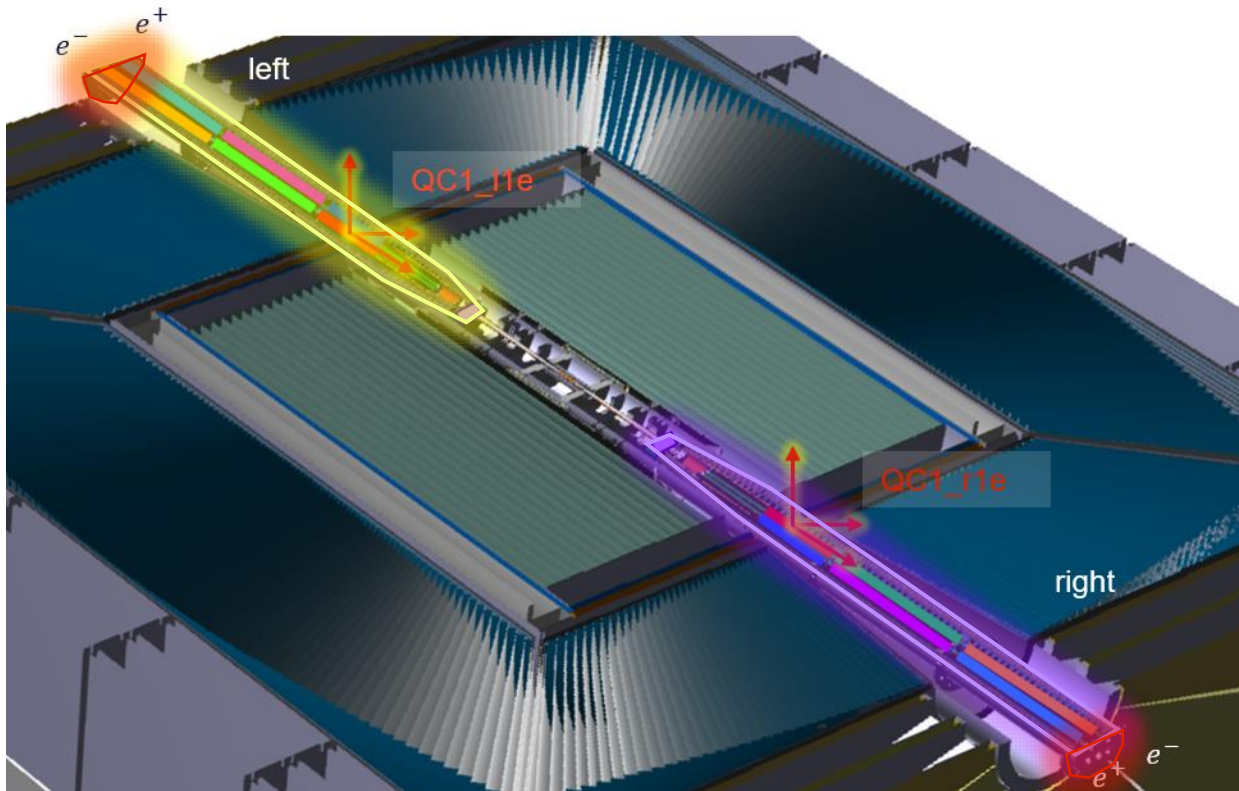

Sub-goal: monitor the alignment between the assembly and the detector (especially the detector solenoid)

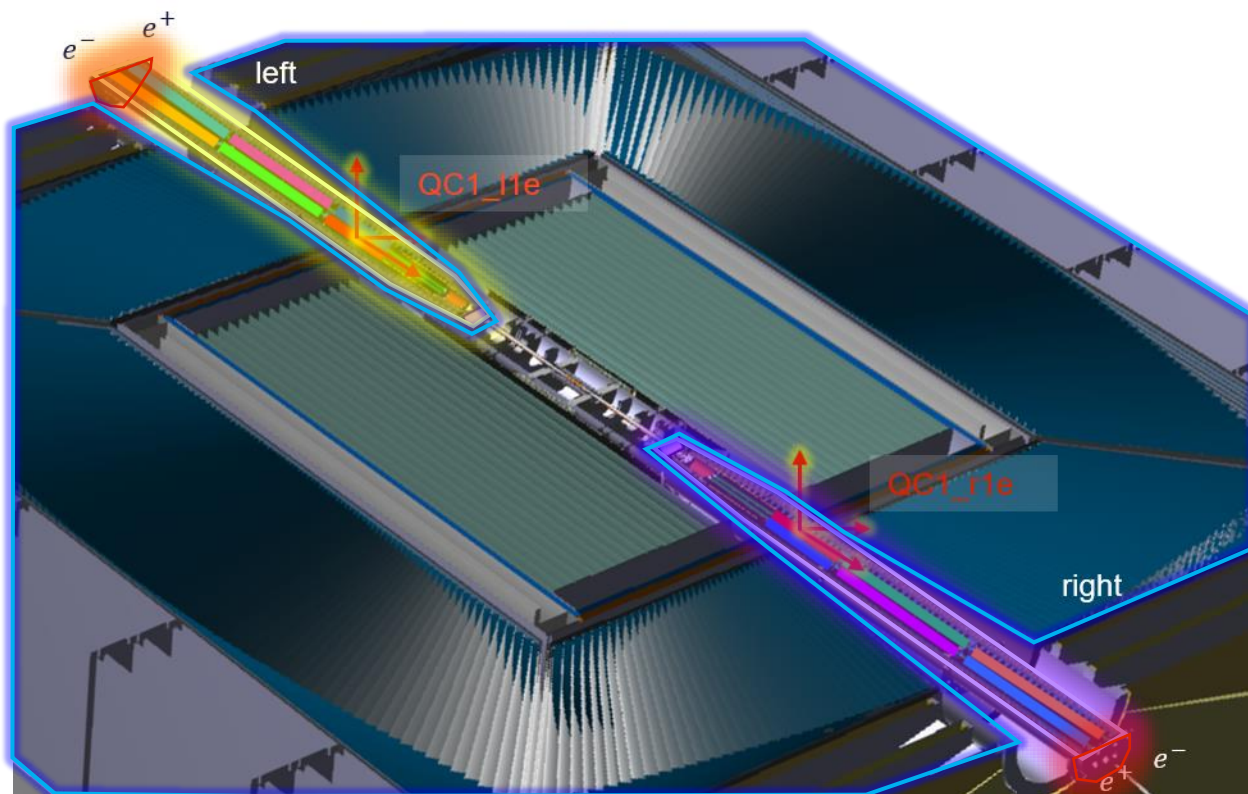

Sub-goal: link the alignment between the assemblies on both sides of the detector

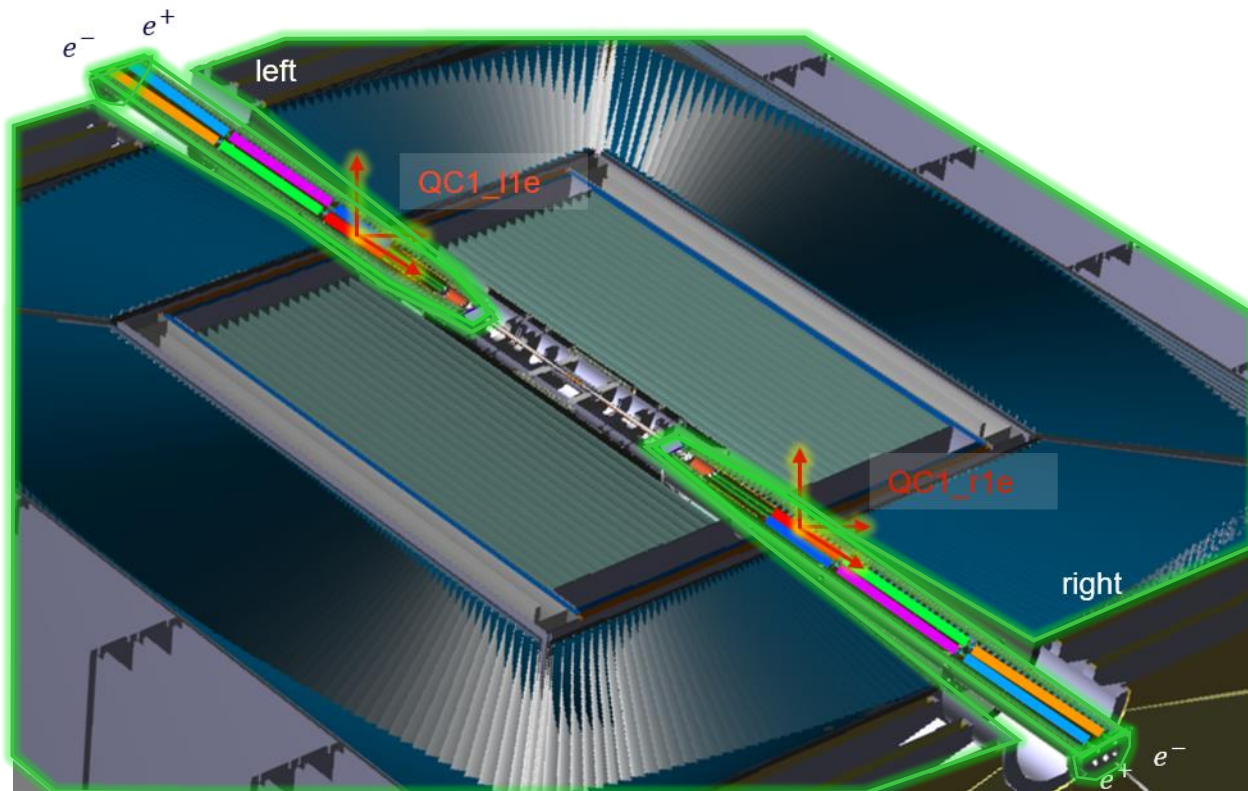

## First: the external alignment system

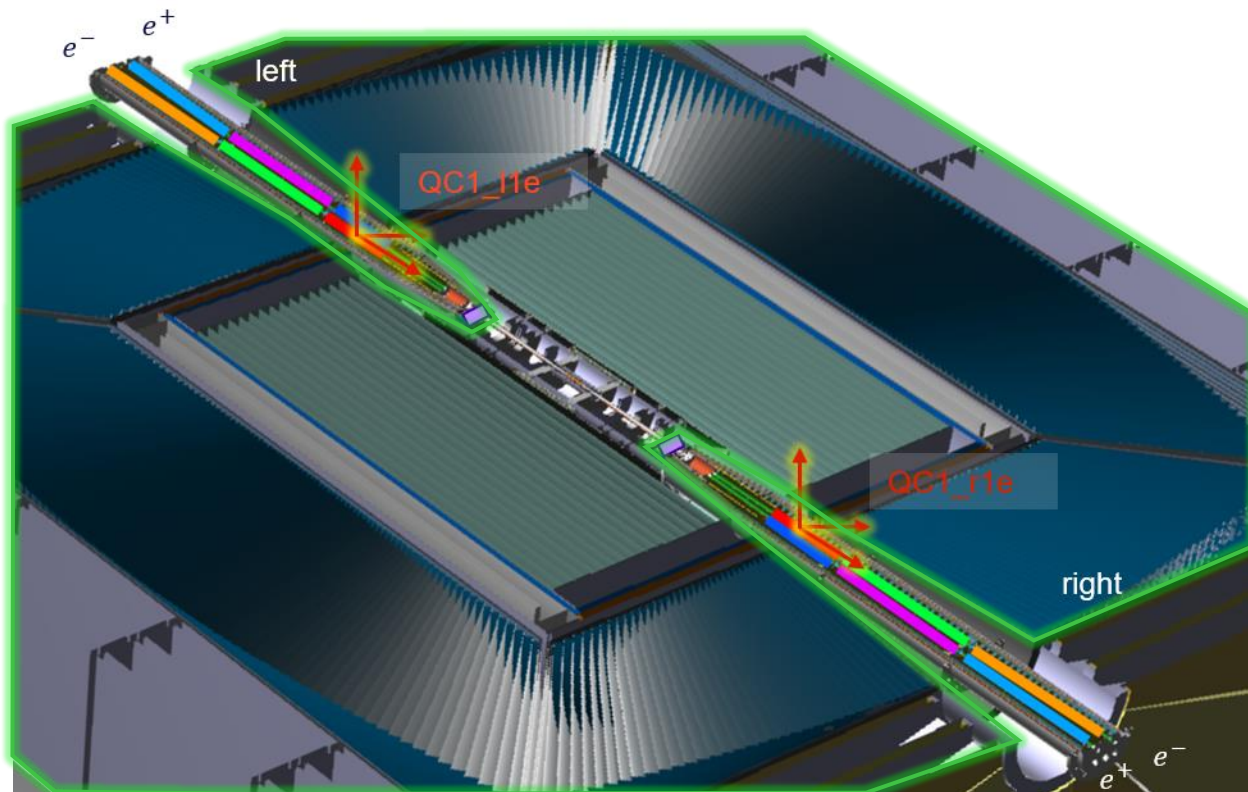

# First: the external alignment system

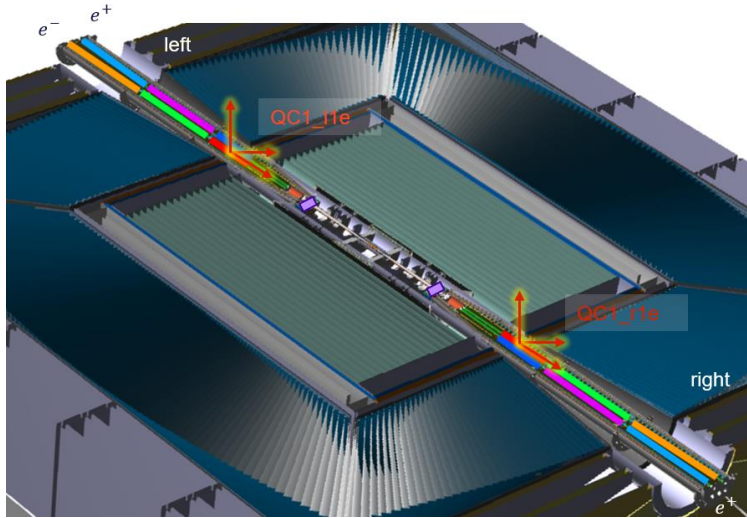

FCC-ee MDI external alignment monitoring system

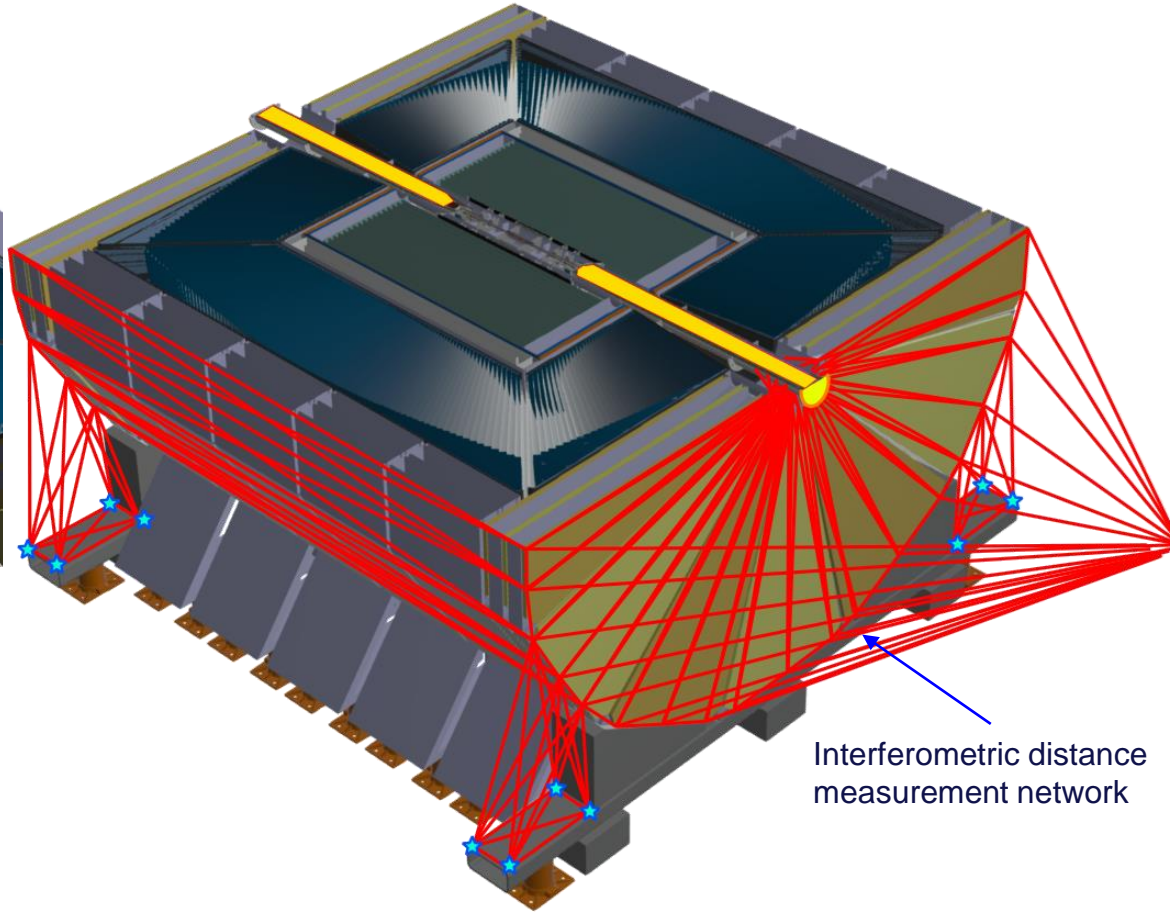

Interferometric distance measurement network

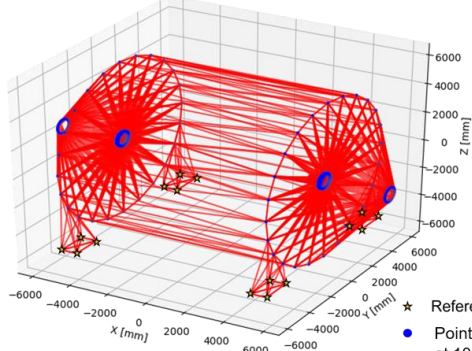

- ★ Reference points
- Points with coordinates known at 10 microns uncertainties

# External alignment system

## Simulations



Permanent network of interferometric distance measurements based on Frequency Scanning Interferometry (FSI).  
Multilateration over the network.

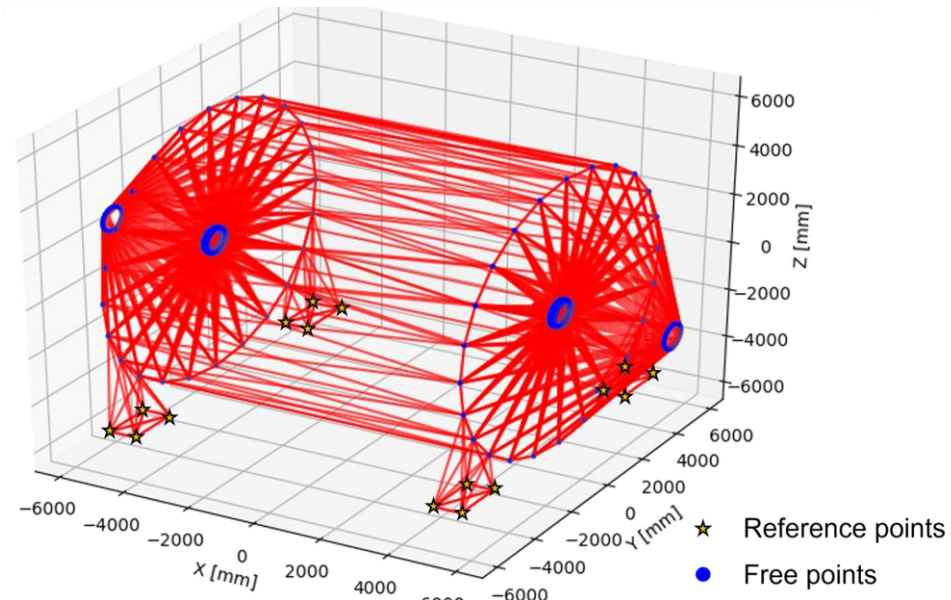

Optimal network : too much measurements, some (plenty) wont be possible.  
Updates on the design are followed carefully.

[Thesis link](#)

# Hardware R&D

## Collimator and Corner Cube retroreflector



## FSI long range validation campaign

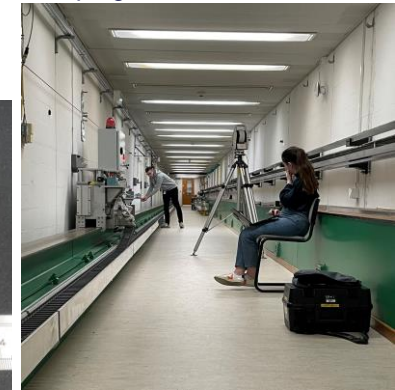

## Glass bead supports

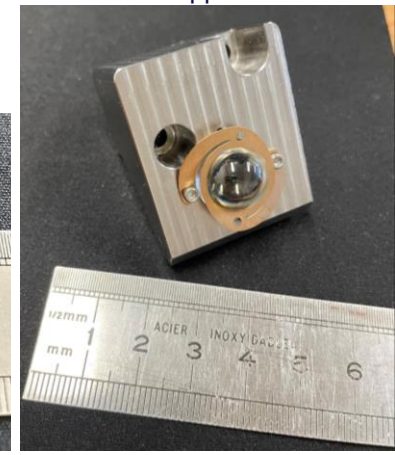

## Glass beads

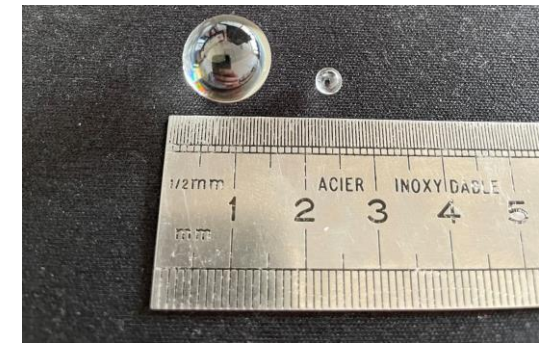

## Second: internal alignment system

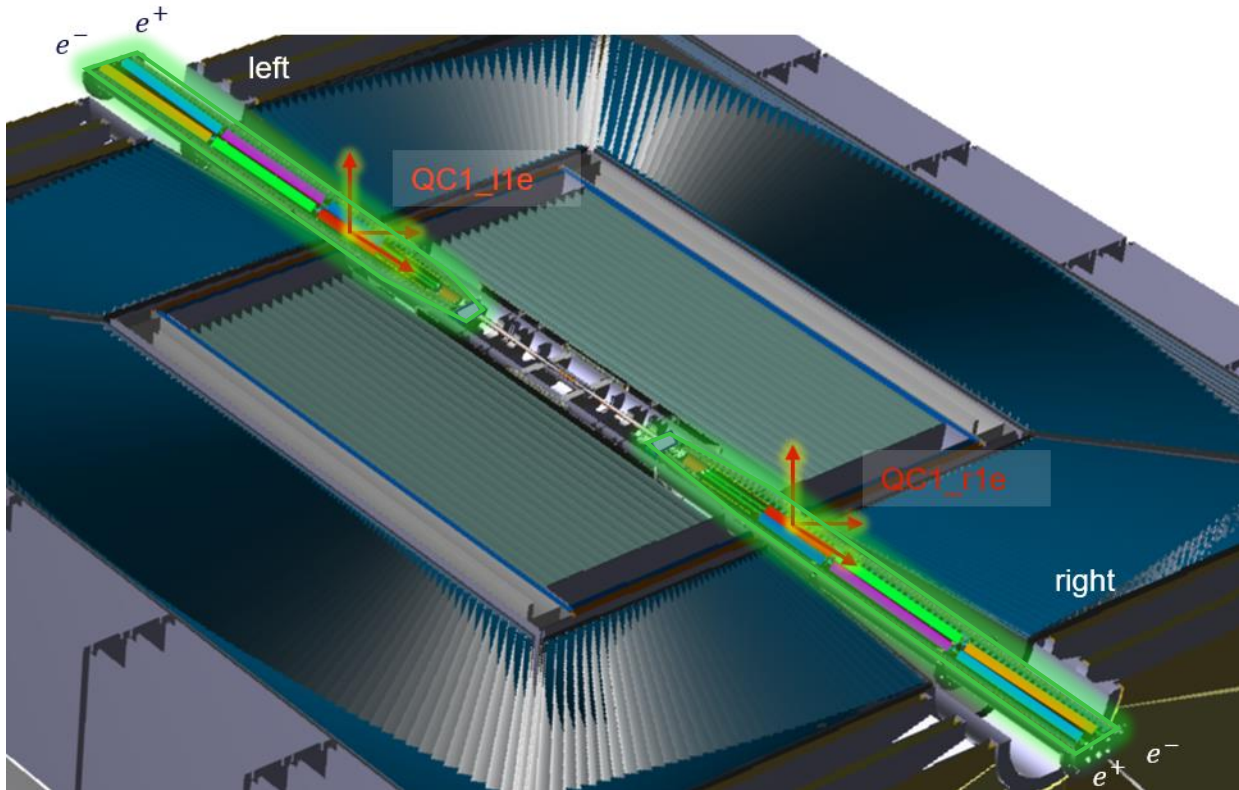

## Second: internal alignment system

- Goal : monitor the deformation extremely precisely over the length of the assembly
- Create a network of points accurate enough so another system can measure from it onto the inner components

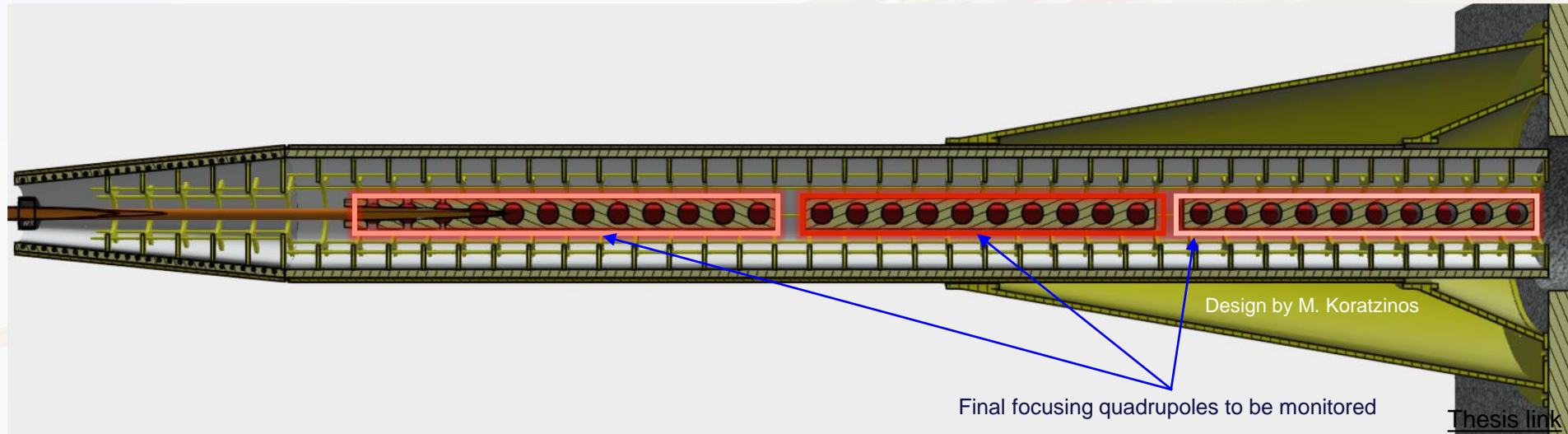

## Second: internal alignment system

- Goal : monitor the deformation extremely precisely over the length of the assembly
- Create a network of points accurate enough so another system can measure from it onto the inner components
- Deformation monitoring system

### Deformation models

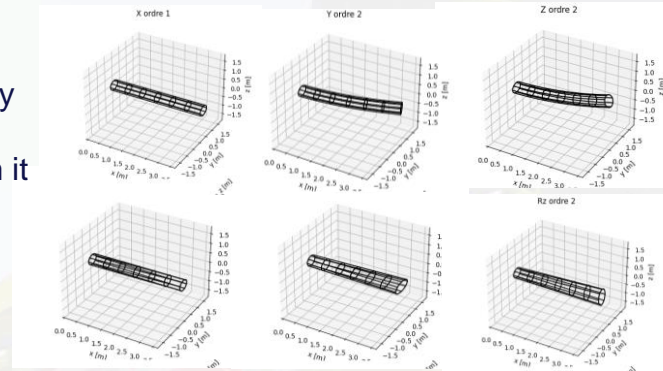

Cylinder of which the deformation is well known and from which we will measure the inner components

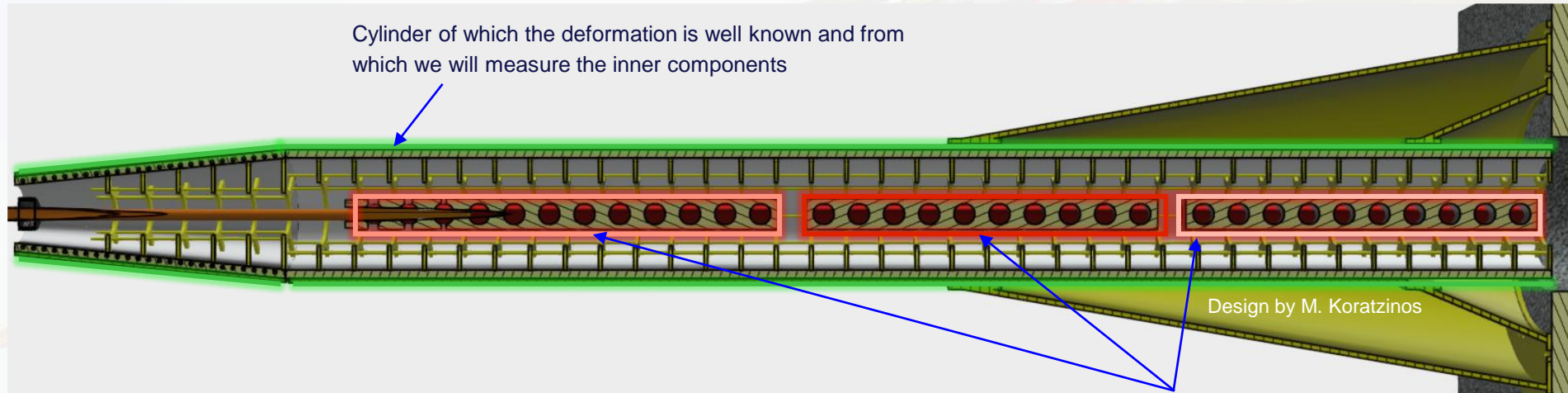

Design by M. Koratzinos

Final focusing quadrupoles to be monitored

## Second: internal alignment system

### Deformation models

- Goal : monitor the deformation extremely precisely over the length of the assembly
- Create a network of points accurate enough so another system can measure from it onto the inner components
- Deformation monitoring system + distance measurement system

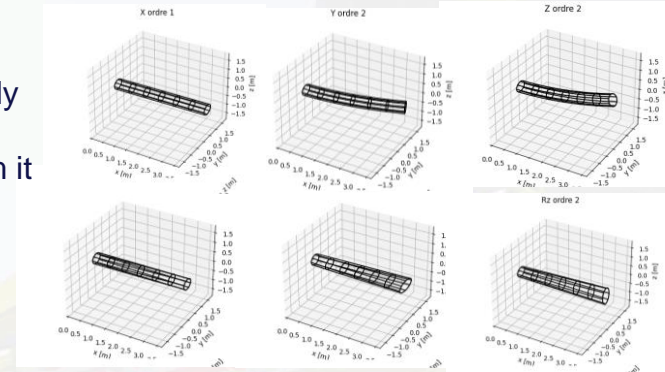

Cylinder of which the deformation is well known and from which we will measure the inner components

Measurement on the inner components

Design by M. Koratzinos

Final focusing quadrupoles to be monitored

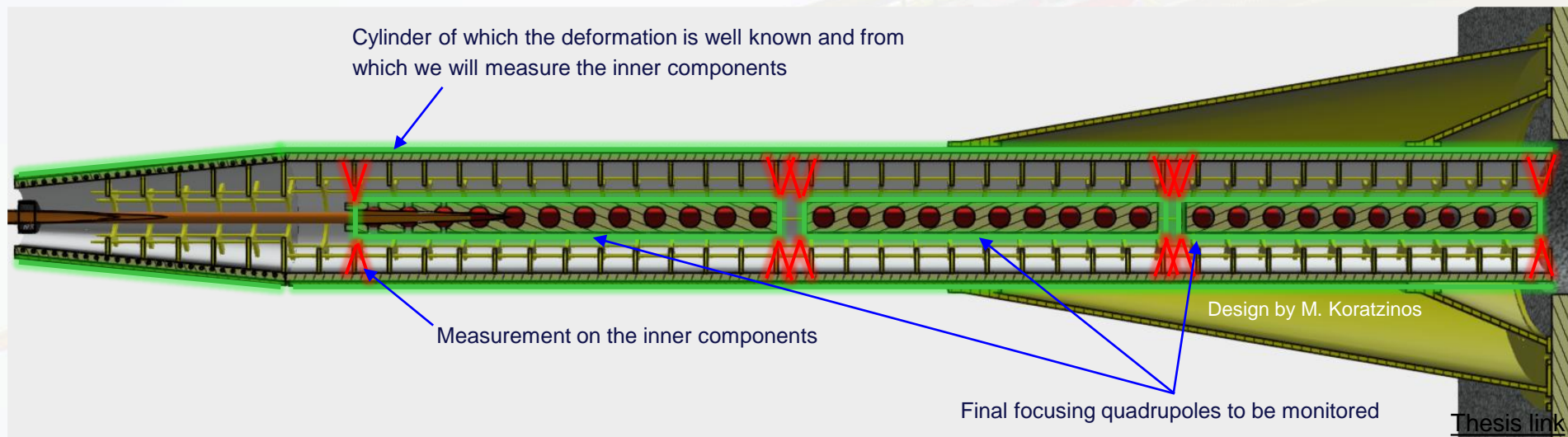

# Deformation monitoring

<https://iopscience.iop.org/article/10.1088/1361-6501/acc6e3>

## Current use of the FSI

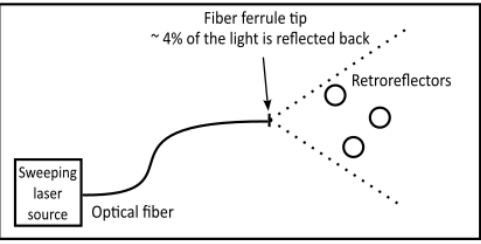

## Example of a FSI head prototype measuring on the cold mass from the cryostat

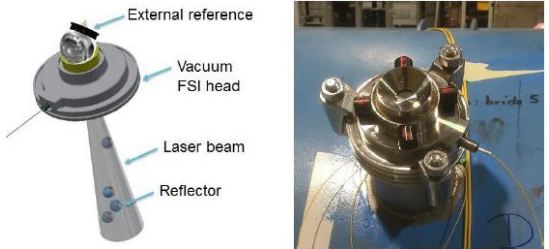

Sosin, M., et al. "Frequency sweeping interferometry for robust and reliable distance measurements in harsh accelerator environment." *Applied Optical Metrology III*, Vol. 11102. SPIE, 2019.

In-fiber measurements can be used to monitor deformations when placed in helix on the studied cylinder, portions measuring the local change of length.

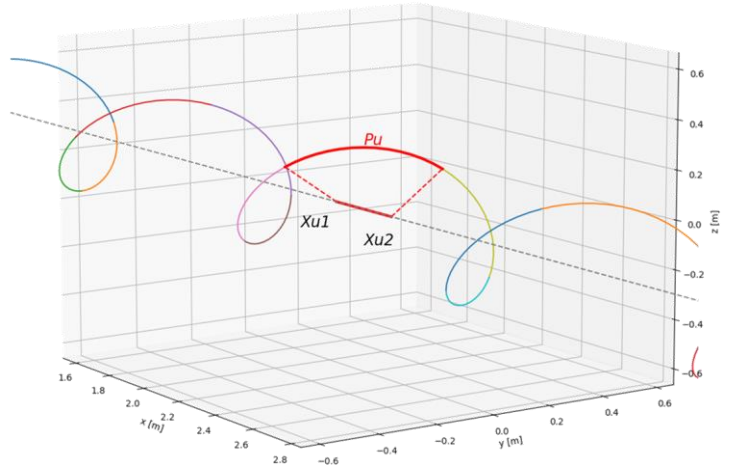

## Multiplexed measurements performed for the FCC

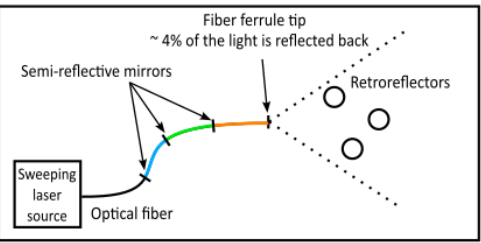

## First prototype for the In-lined Multiplexed and Distributed FSI (cf. article)

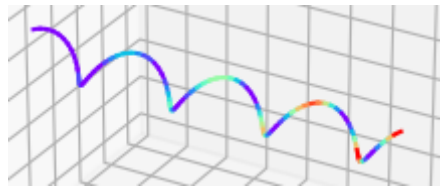
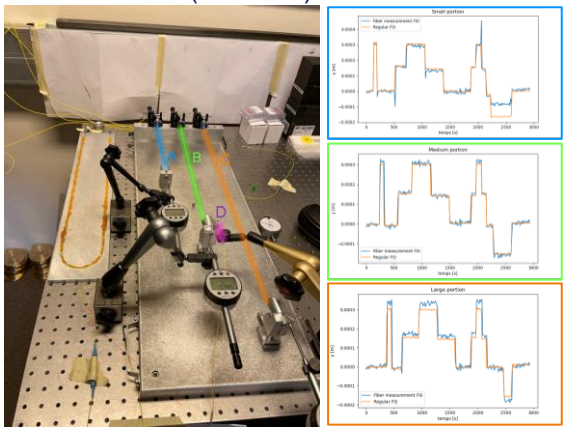

# Deformation monitoring

<https://iopscience.iop.org/article/10.1088/1361-6501/acc6e3>

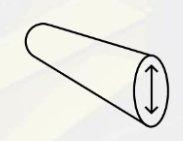
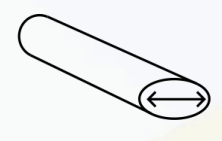
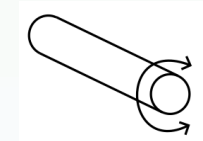
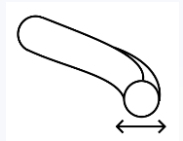
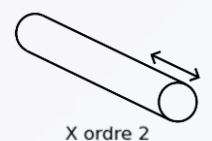

Ry ordre 1

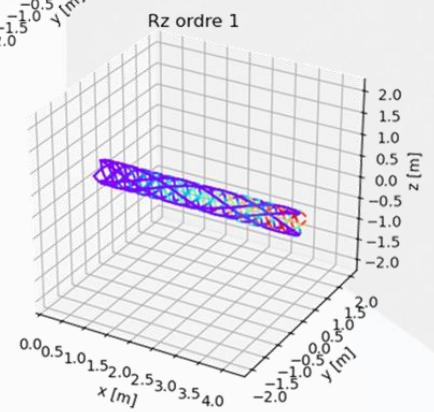
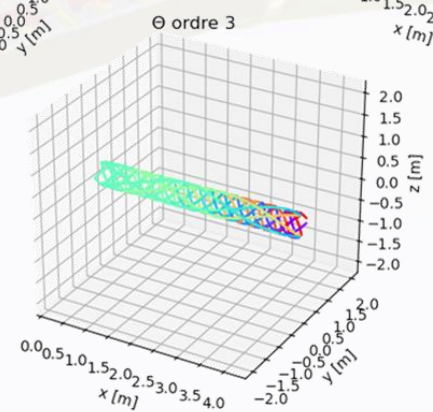
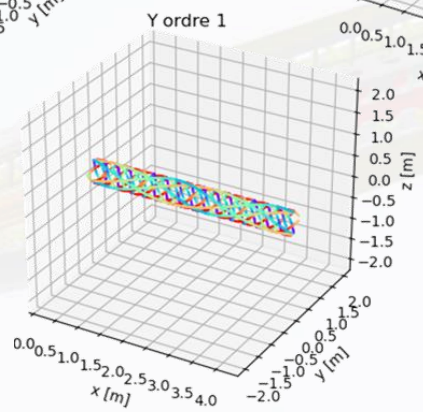
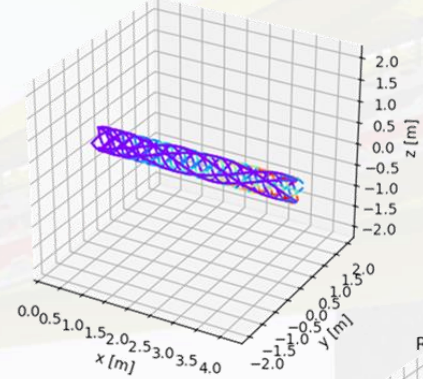
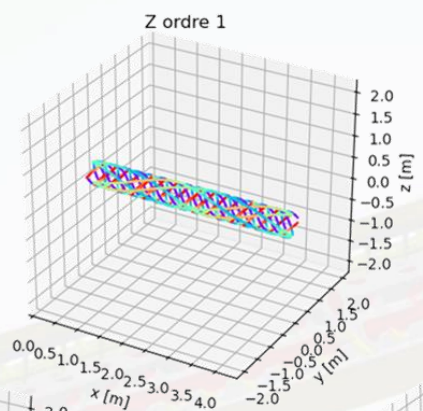
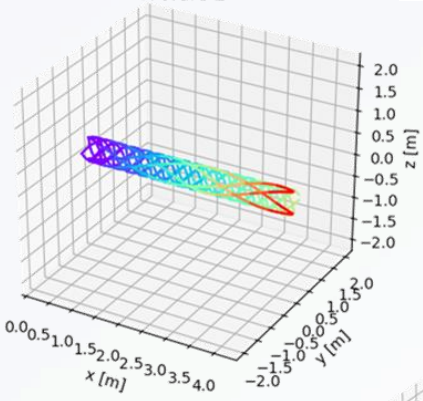

# Deformation monitoring

<https://iopscience.iop.org/article/10.1088/1361-6501/acc6e3>

## Cylinder deformations

Helixes observations  
(= 3D lengths of portions)

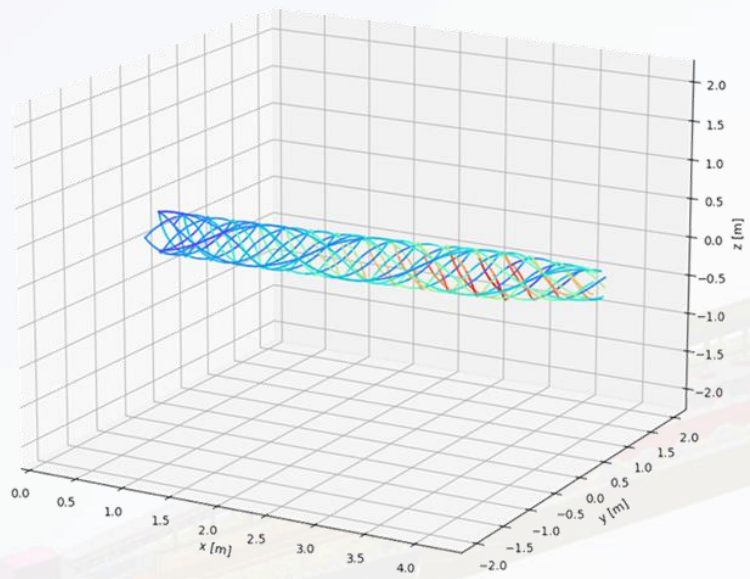

+ equation of portion length as function of the deformation polynomials

Total : 3600 measurements and  $\approx 3 \text{ cm}^3$  space taken by the sensing system in the assembly.

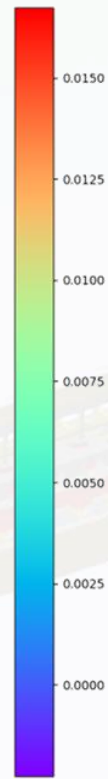

Least square adjustment

$$P_x(t) = \sum_{i=1}^n a_i t^i$$

$$P_y(t) = \sum_{i=1}^n b_i t^i$$

$$P_z(t) = \sum_{i=1}^n c_i t^i$$

$$P_\theta(t) = \sum_{i=1}^n d_i t^i$$

$$P_{r_{xy}}(t) = \sum_{i=1}^n e_i t^i$$

$$P_{r_{xz}}(t) = \sum_{i=1}^n f_i t^i$$

Simulations shown micrometric accuracy  
To be confirmed by a prototype

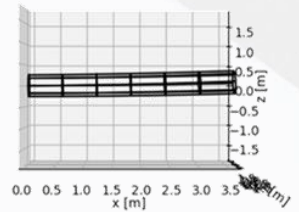
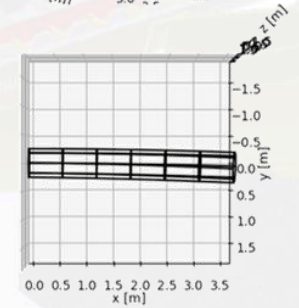
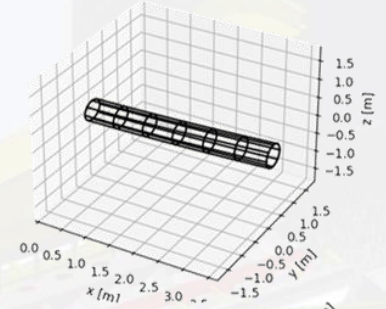

# Latest and ongoing prototypes

Sensor glued on an aluminum plate

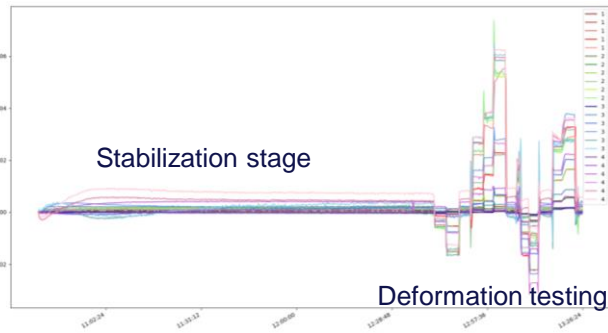
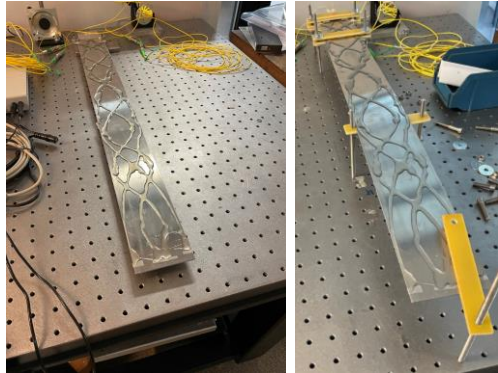

# Latest and ongoing prototypes

Sensor glued on an aluminum plate

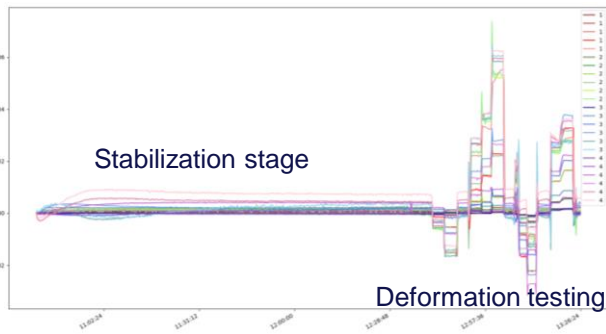
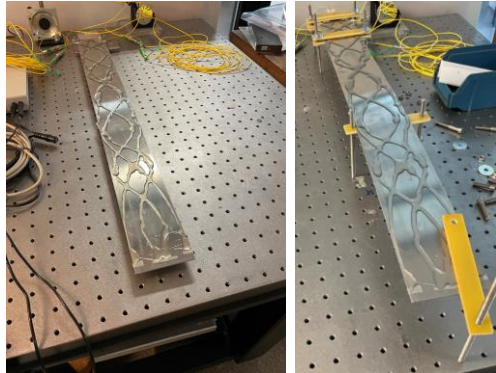

First prototype with helix fibers



Monitoring of the glue curing

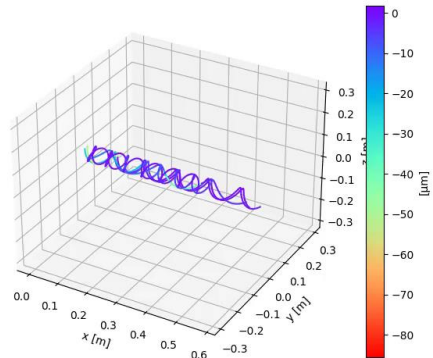

Fiber section measurements

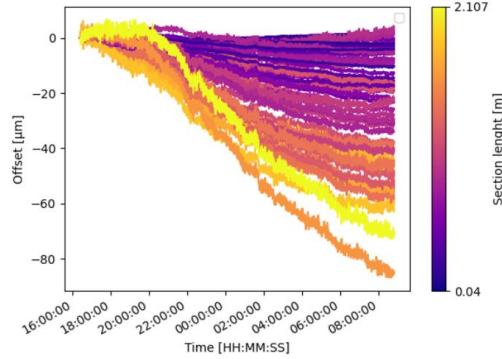

# Latest and ongoing prototypes

Sensor glued on an aluminum plate

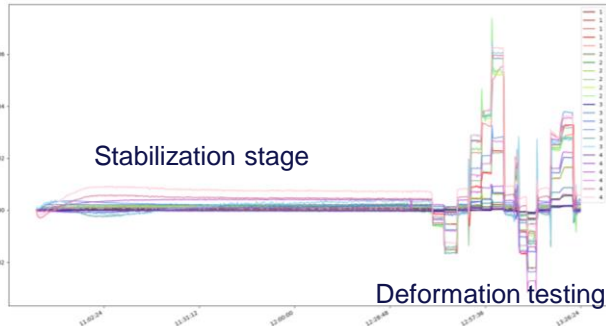
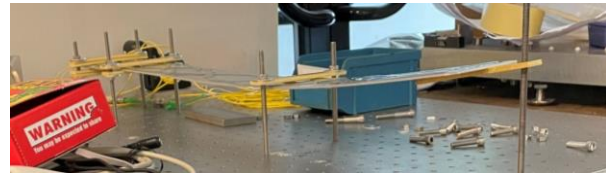
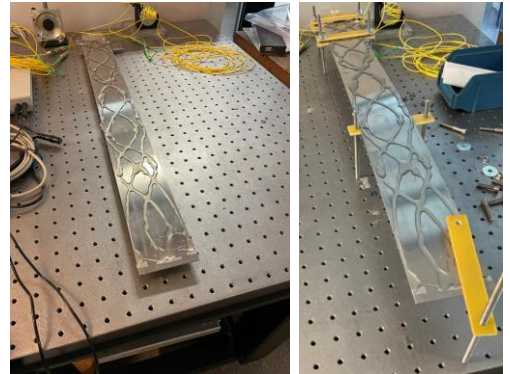

First prototype with helix fibers



Monitoring of the glue curing

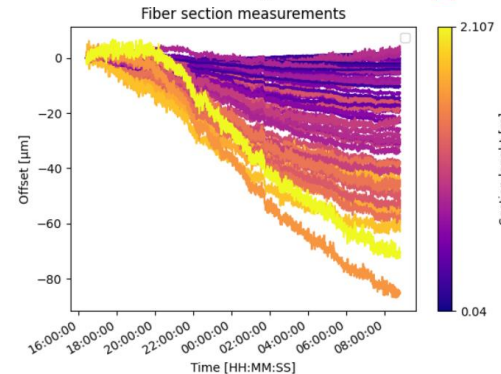
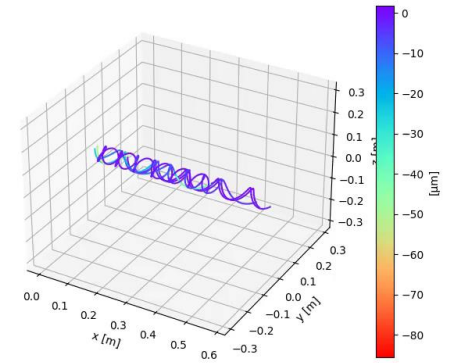

Prototype implementing the fiber measurement and the FSI measurement on reflector

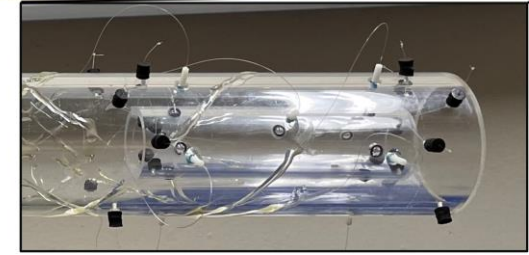
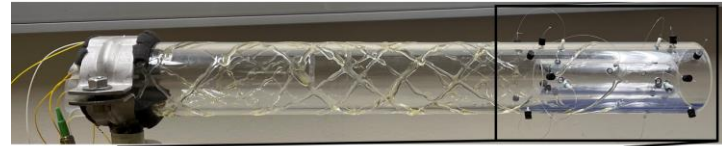

Measurements performed by a single fiber fiber

Tube prototype measurement, measurements in fiber and on the glass bead

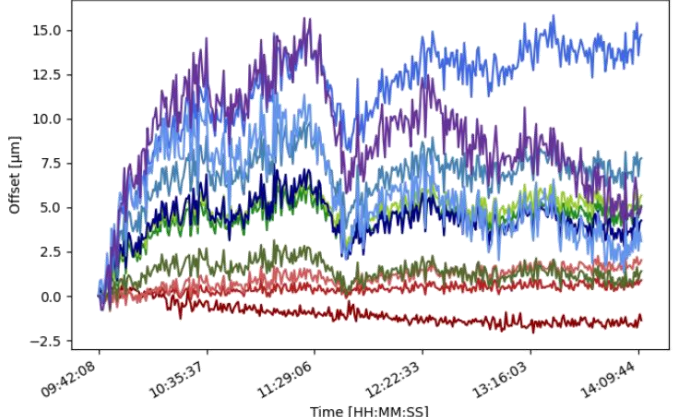

## MDI alignment monitoring mock-up: design and goal

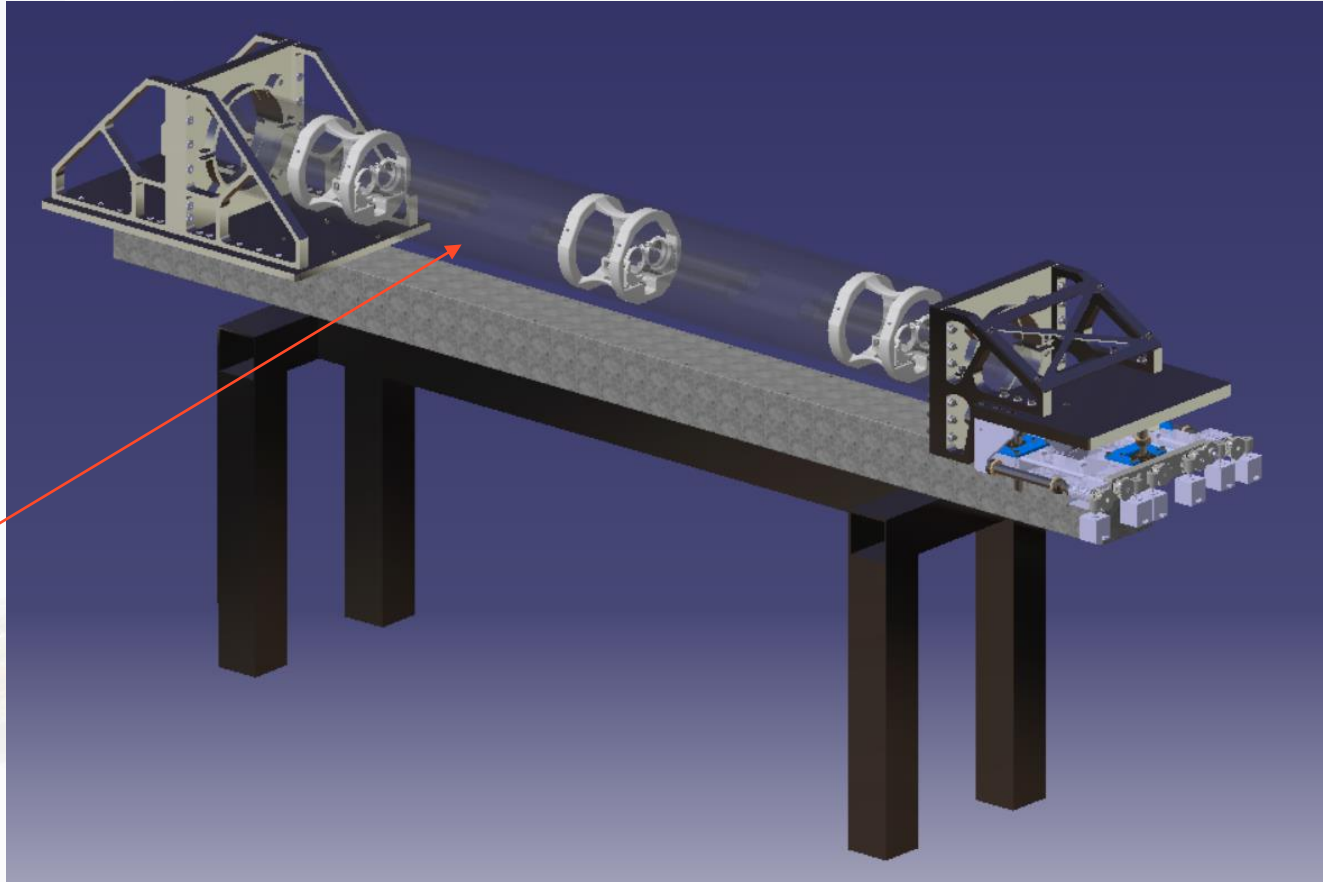

2m long plastic tube,  
simulating the support  
of the screening  
solenoid on which the  
fibers will be installed

## MDI alignment monitoring mock-up: design and goal

Stable support,  
simulating the support  
outside the detector

2m long plastic tube,  
simulating the support  
of the screening  
solenoid on which the  
fibers will be installed

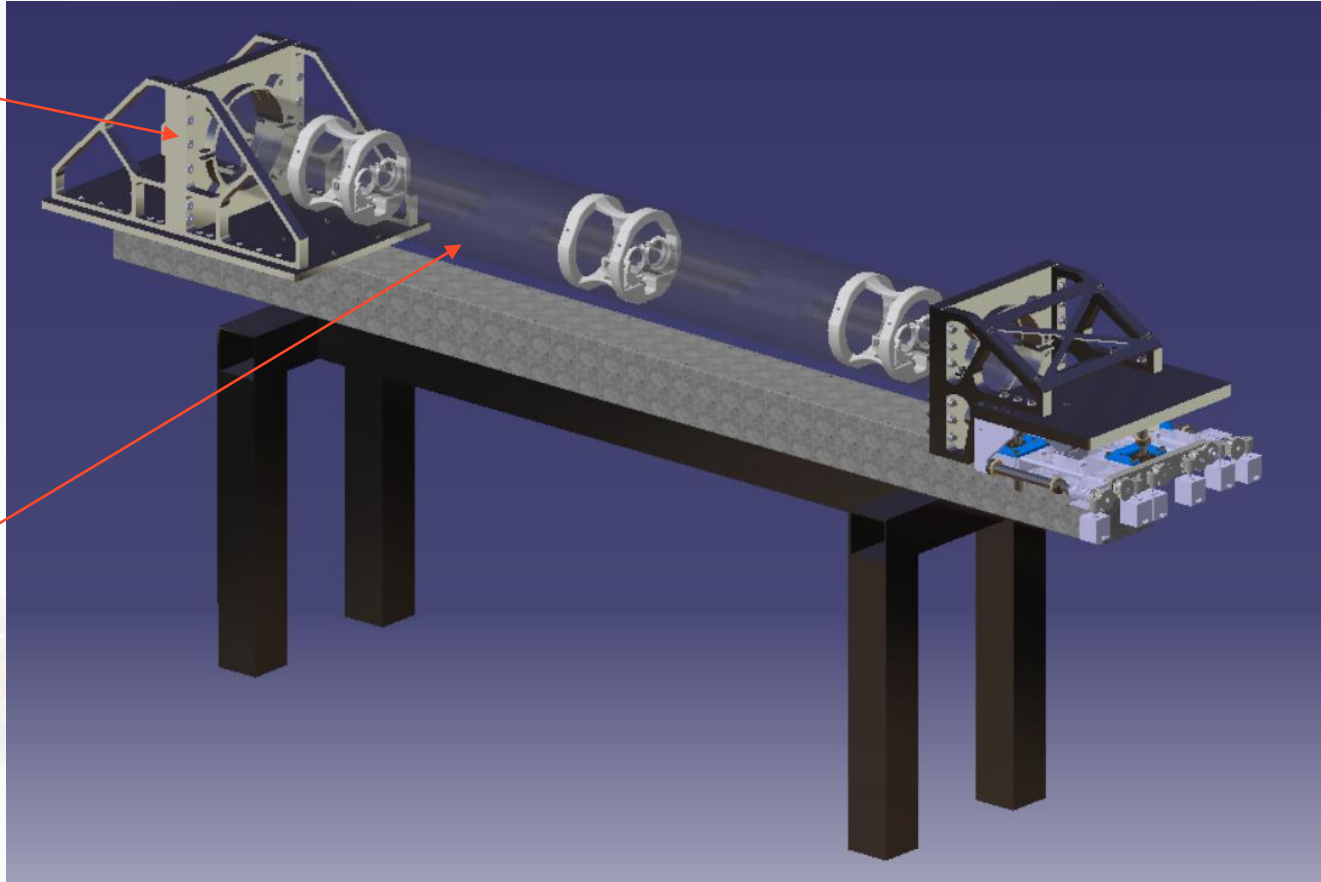

## MDI alignment monitoring mock-up: design and goal

Stable support,  
simulating the support  
outside the detector

2m long plastic tube,  
simulating the support  
of the screening  
solenoid on which the  
fibers will be installed

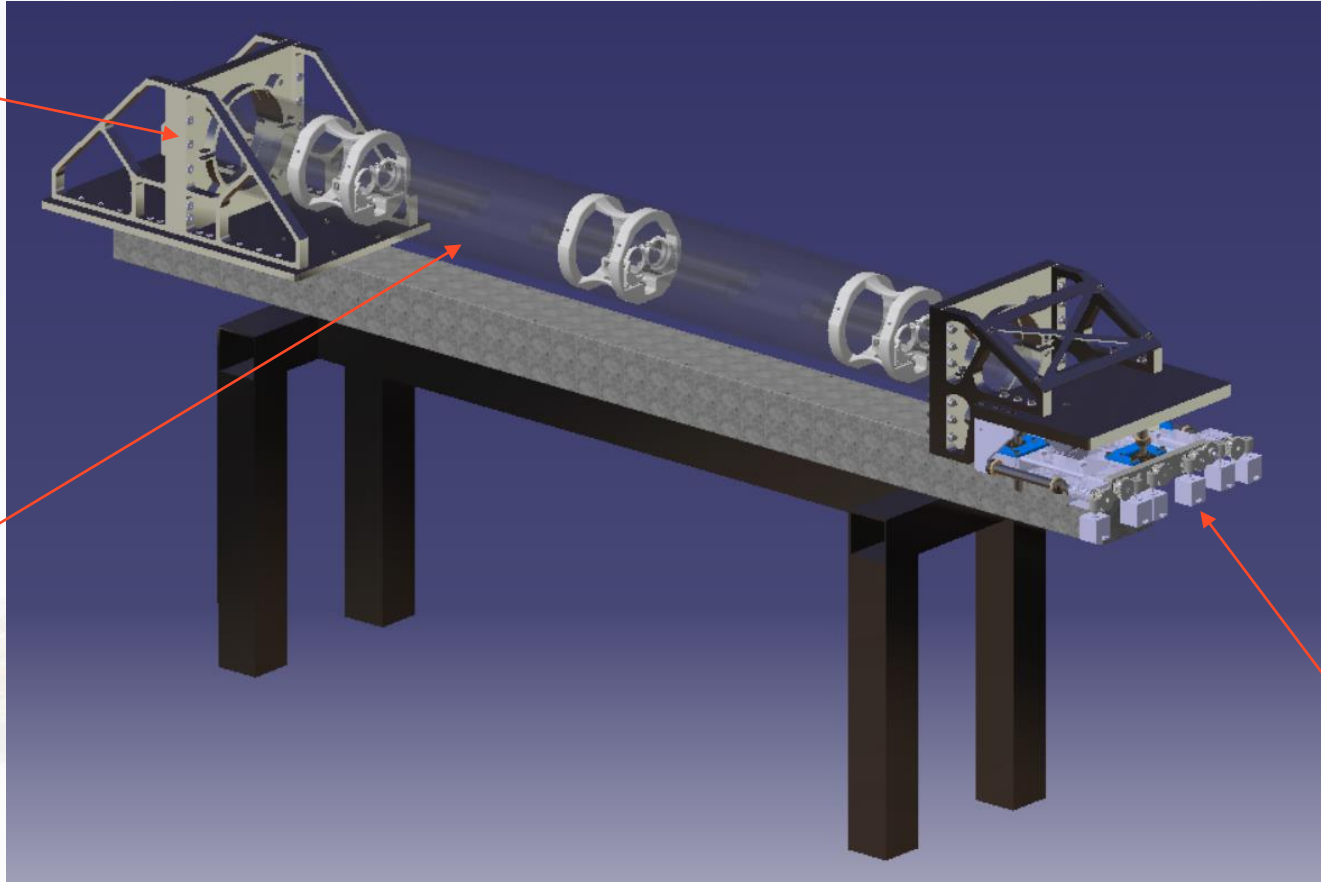

Very precise movable  
plate (Universal  
Adjustment Platform)  
to induce deformations

## MDI alignment monitoring mock-up: design and goal

Stable support,  
simulating the support  
outside the detector

2m long plastic tube,  
simulating the support  
of the screening  
solenoid on which the  
fibers will be installed

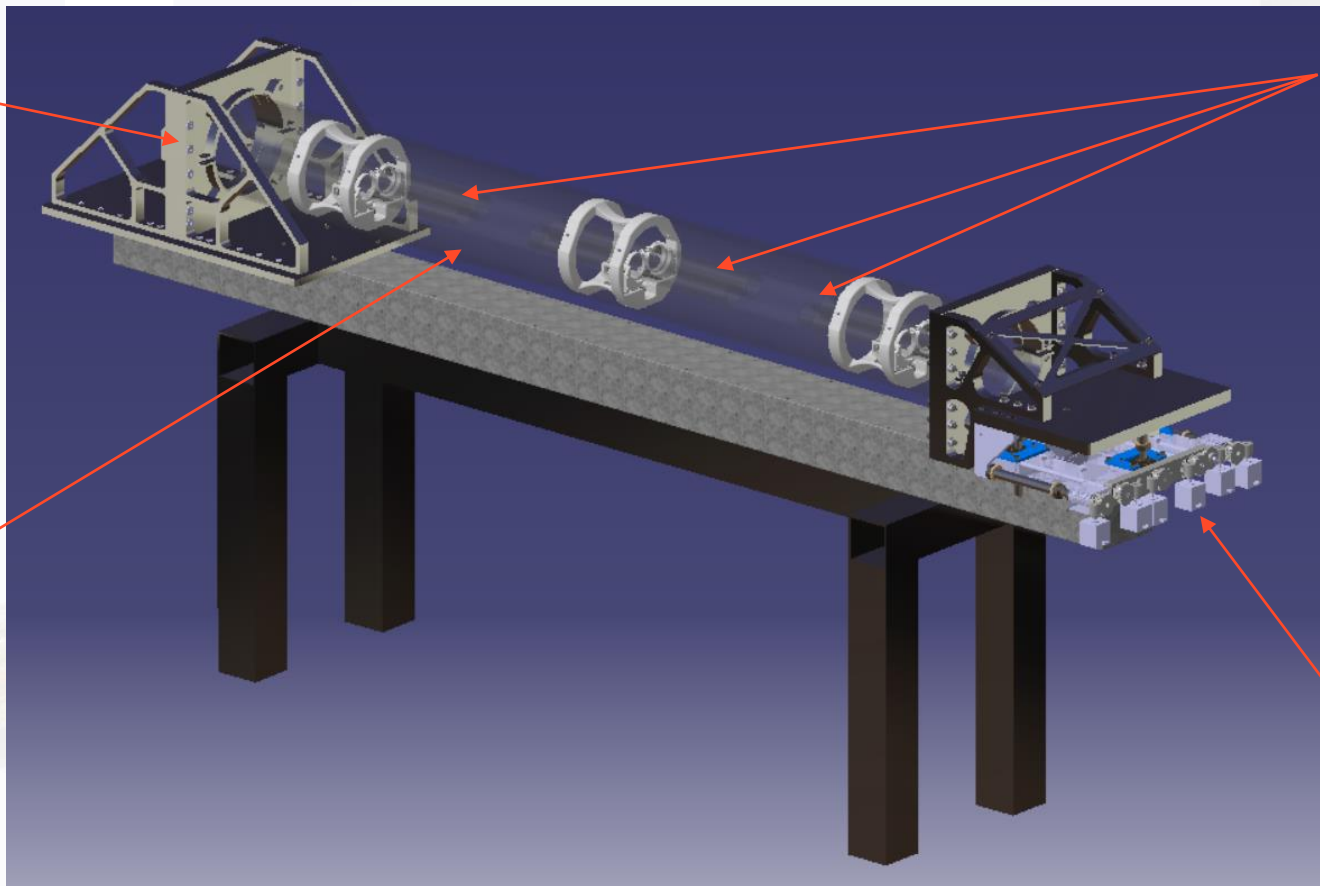

6x Smaller plastic tubes  
simulating the final  
focusing quadrupoles

Very precise movable  
plate (Universal  
Adjustment Platform)  
to induce deformations

## MDI alignment monitoring mock-up: design and goal

Stable support,  
simulating the support  
outside the detector

2m long plastic tube,  
simulating the support  
of the screening  
solenoid on which the  
fibers will be installed

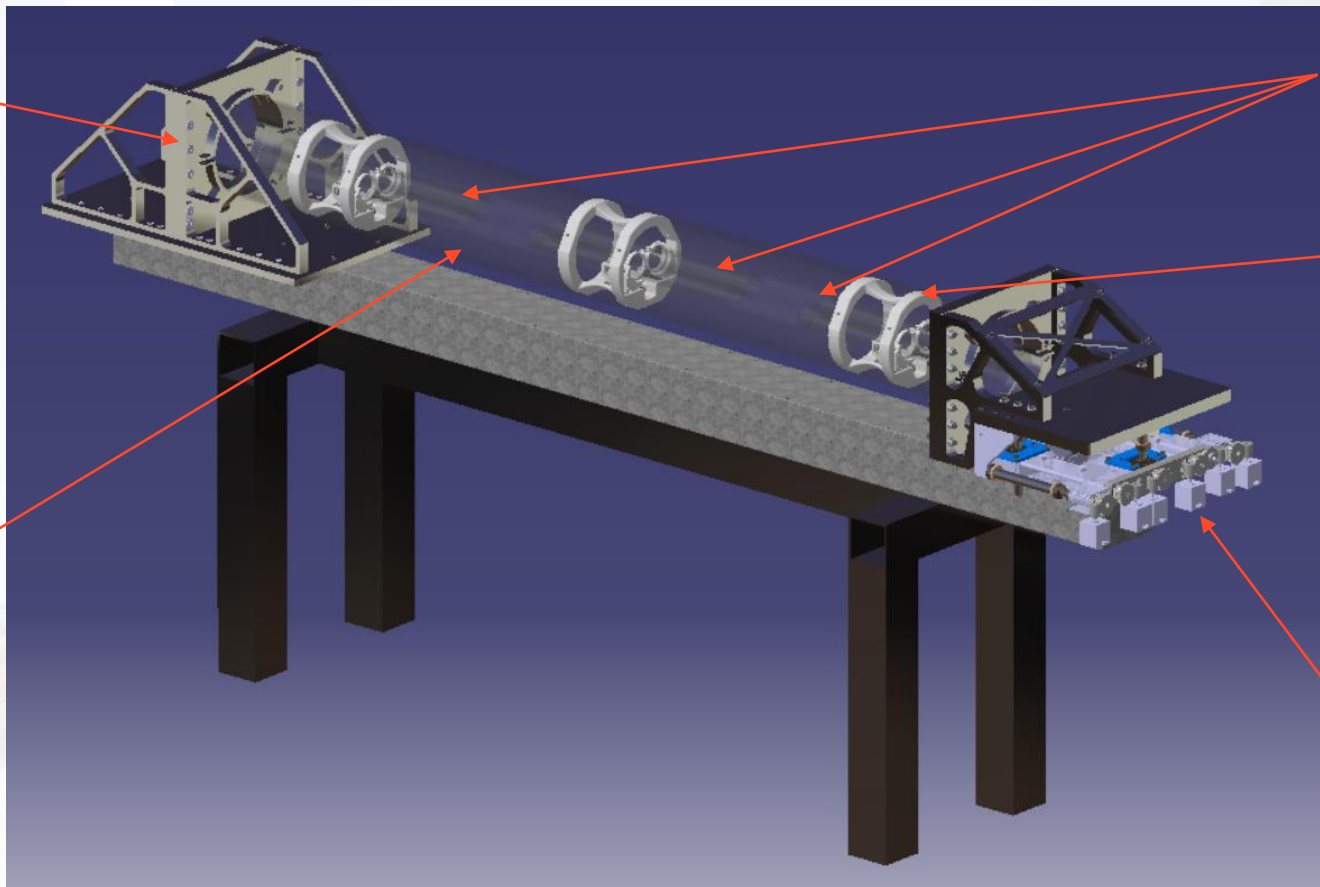

6x Smaller plastic tubes  
simulating the final  
focusing quadrupoles

3D printed supports and  
motorised kinematic  
mounts for the  
simulated final focusing  
quadrupoles

Very precise movable  
plate (Universal  
Adjustement Platform)  
to induce deformations

## MDI alignment monitoring mock-up: first assembly

First assembly of the alignment monitoring mock-up.  
UAP is being updated.  
Initial deformation tests to be done using a dummy cylinder.

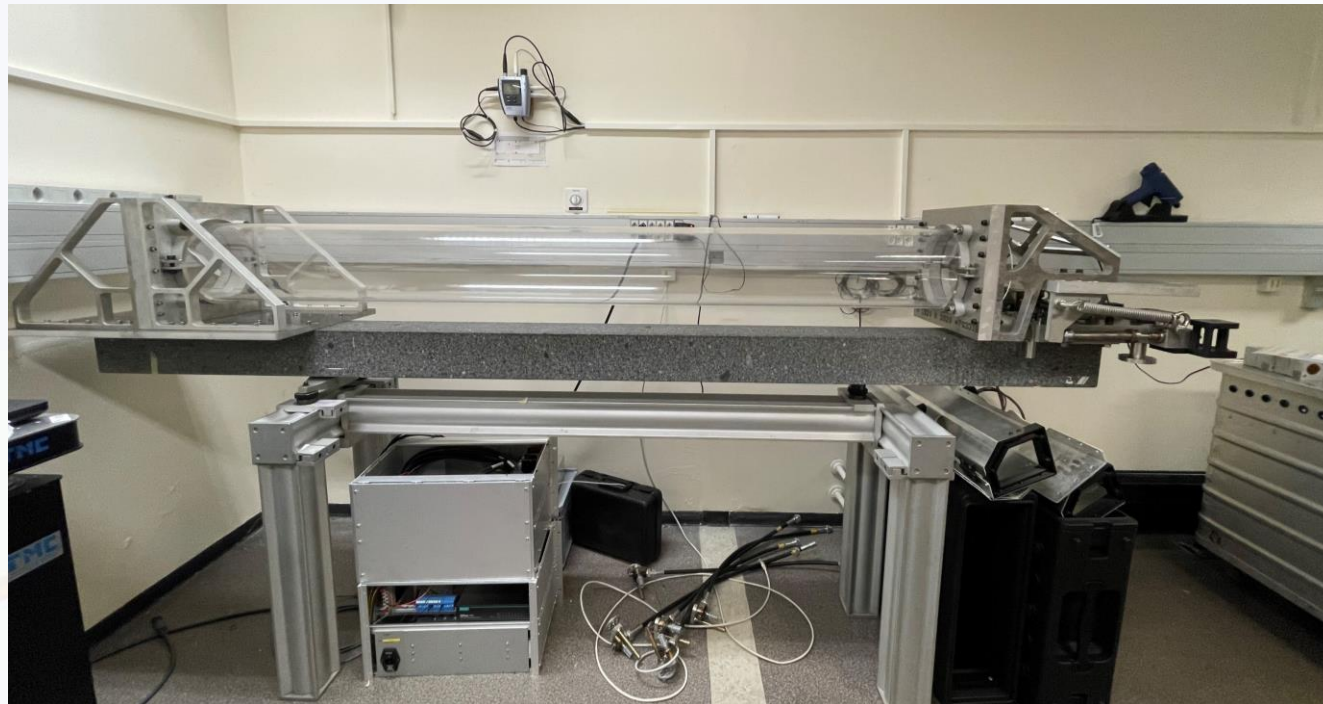

## MDI alignment monitoring mock-up: first assembly

First assembly of the alignment monitoring mock-up.  
UAP is being updated.  
Initial deformation tests to be done using a dummy cylinder.

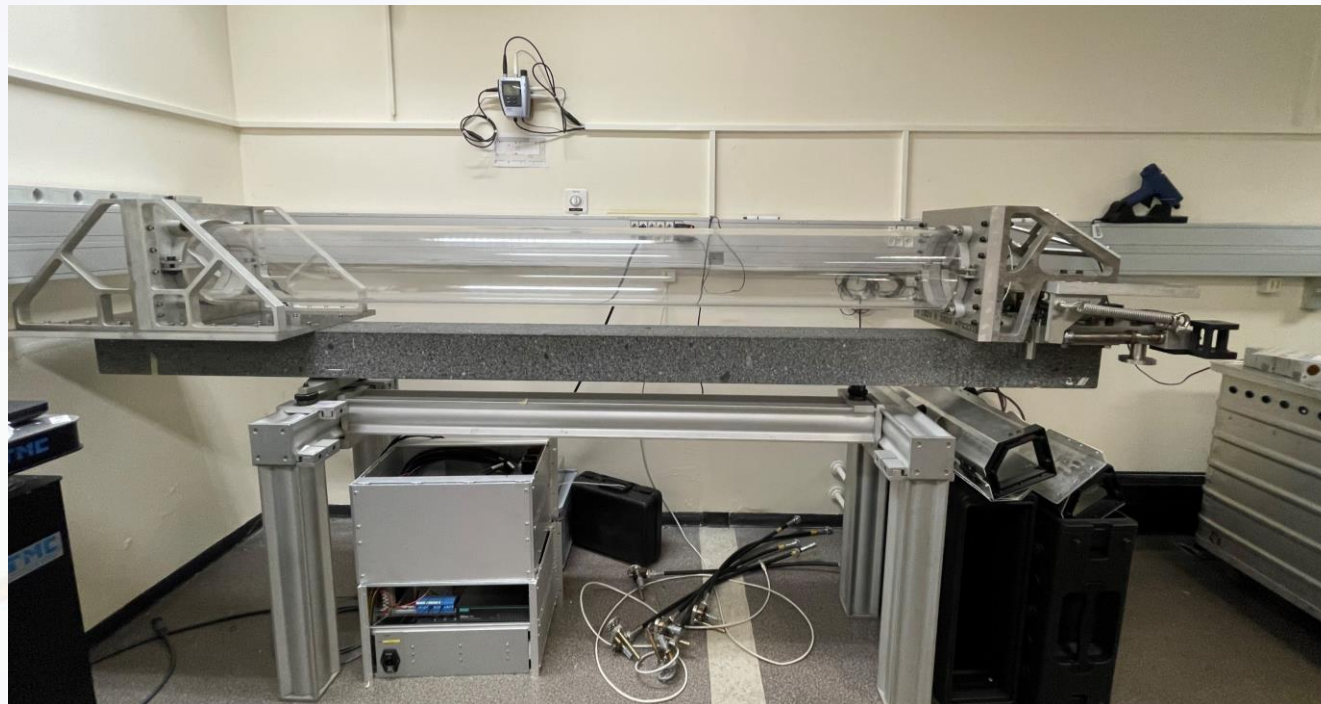

3D printed supports for the smaller cylinders



## MDI alignment monitoring mock-up: first assembly

First assembly of the alignment monitoring mock-up.  
UAP is being updated.  
Initial deformation tests to be done using a dummy cylinder.

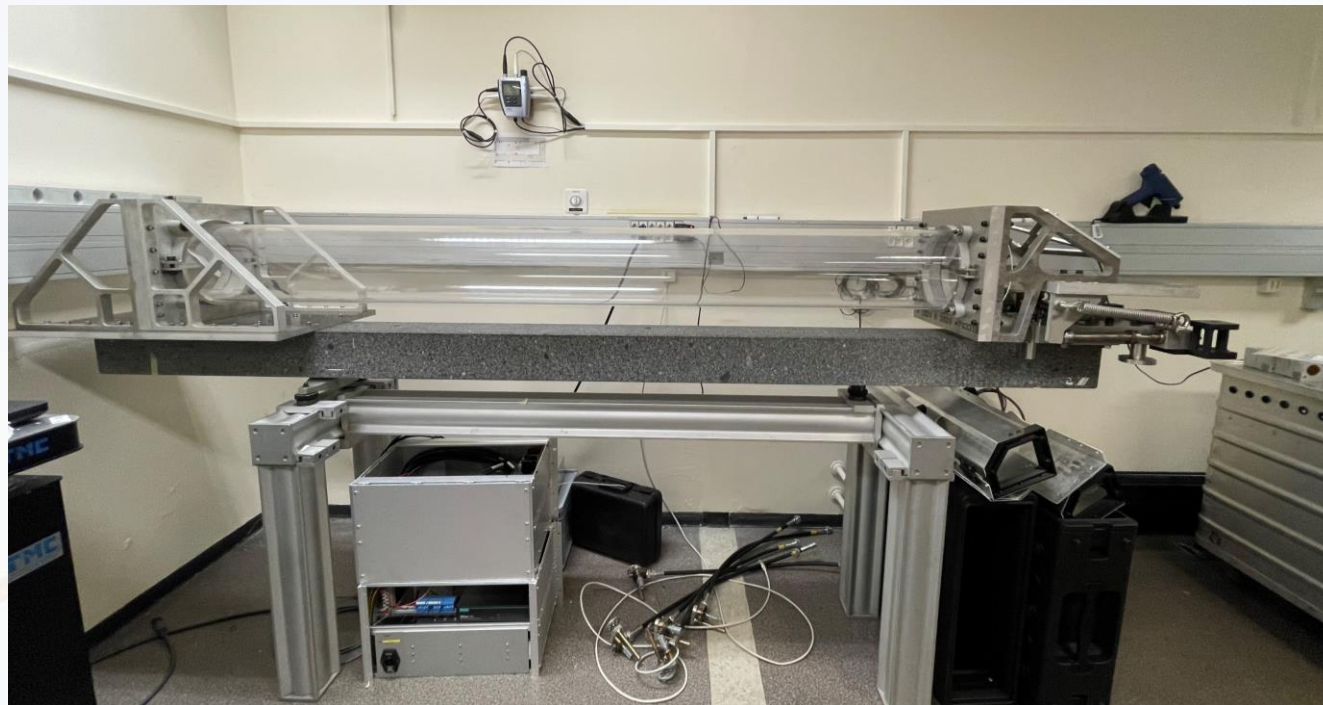

3D printed supports for the smaller cylinders



New controls and gears for the UAP



## MDI alignment monitoring mock-up: FSI heads preparation

Preparation of FSI heads that will perform the classic “in-air” measurement towards the final focusing quadrupoles.

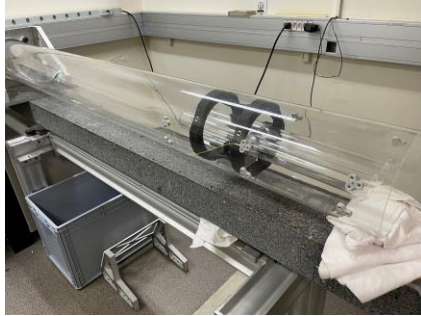

## MDI alignment monitoring mock-up: FSI heads preparation

Preparation of FSI heads that will perform the classic “in-air” measurement towards the final focusing quadrupoles.

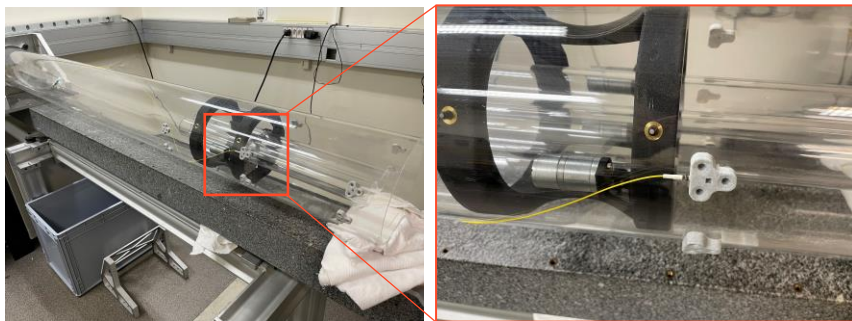

## MDI alignment monitoring mock-up: FSI heads preparation

Preparation of FSI heads that will perform the classic “in-air” measurement towards the final focusing quadrupoles.

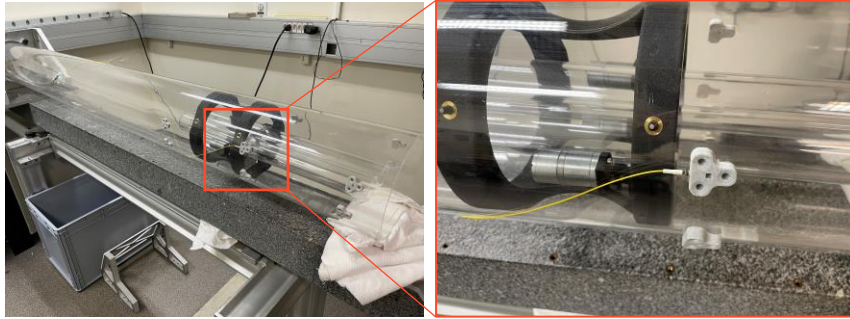

Gluing of the magnets



## MDI alignment monitoring mock-up: FSI heads preparation

Preparation of FSI heads that will perform the classic “in-air” measurement towards the final focusing quadrupoles.

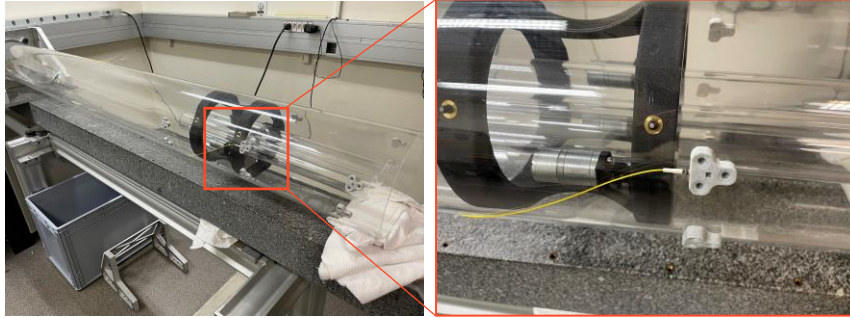

Gluing of the magnets



Installation of the prisms and checking the measuring cone

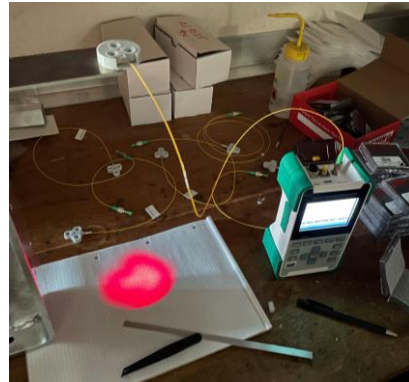

## MDI alignment monitoring mock-up: FSI heads preparation

Preparation of FSI heads that will perform the classic “in-air” measurement towards the final focusing quadrupoles.

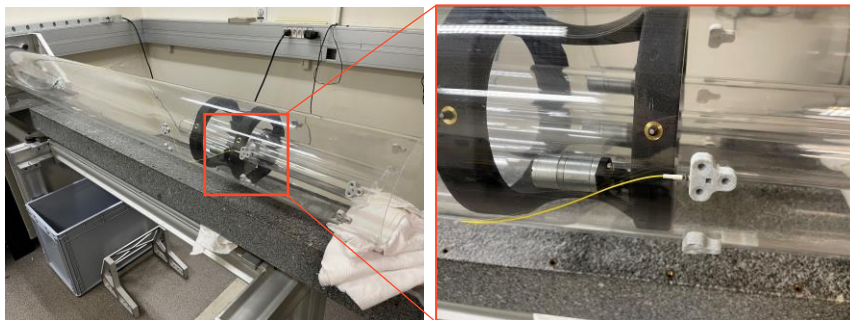

Gluing of the magnets



Installation of the prisms and checking the measuring cone

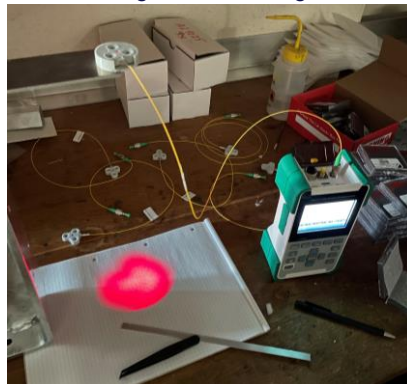

Gluing of the prisms, ready for the calibration

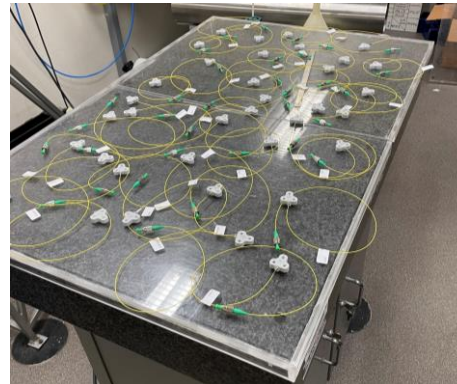

# MDI alignment monitoring mock-up: FSI heads preparation

Preparation of FSI heads that will perform the classic "in-air" measurement towards the final focusing quadrupoles.

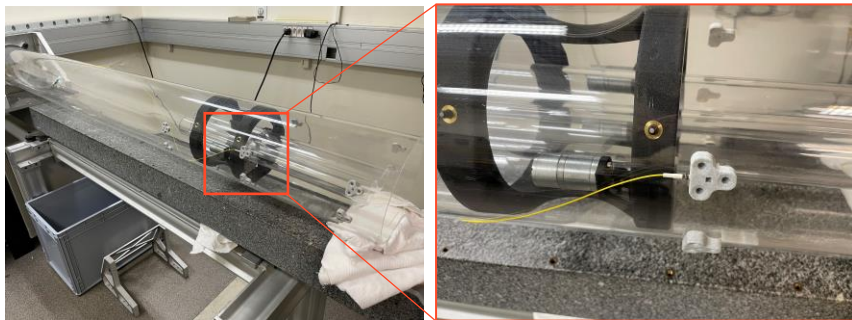

Calibration of all measuring heads thanks to a calibration bench



Gluing of the magnets



Installation of the prisms and checking the measuring cone

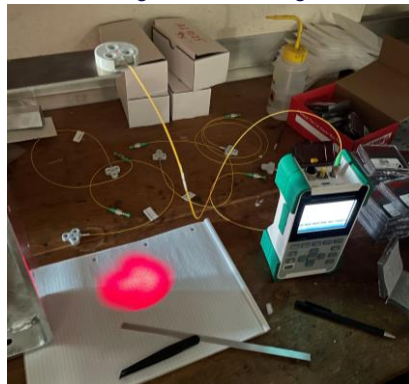

Gluing of the prisms, ready for the calibration

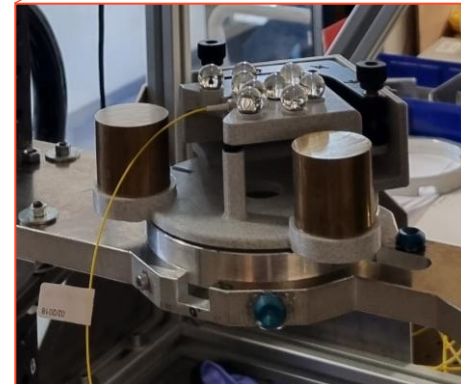
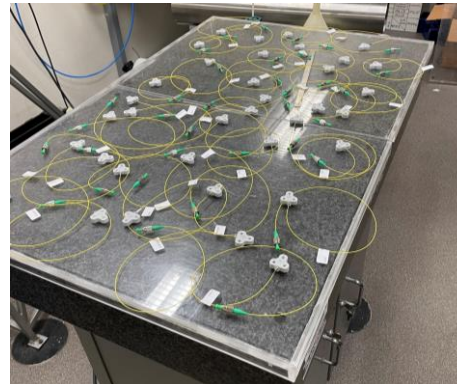

## Vertex detector geometry monitoring

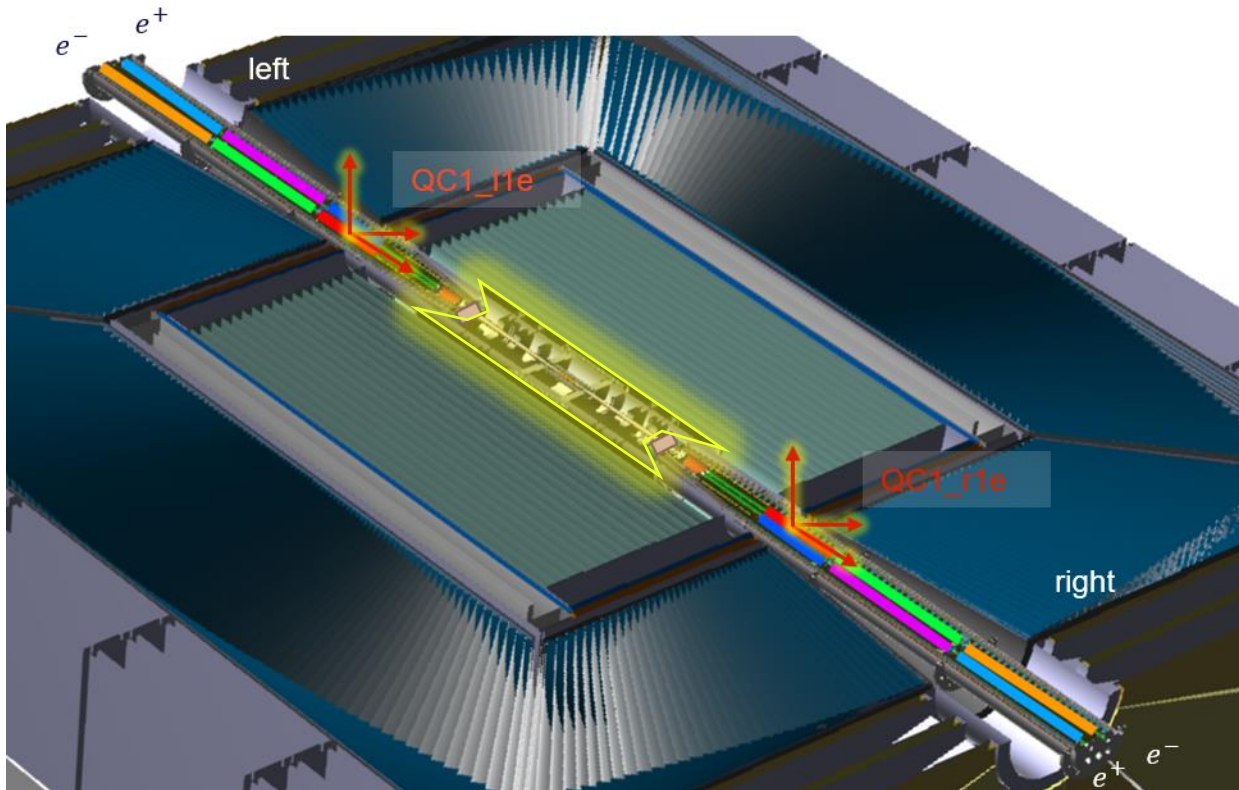

# To put to perspective : subdetector monitoring systems installed inside ATLAS

ATLAS SemiConductor Tracker

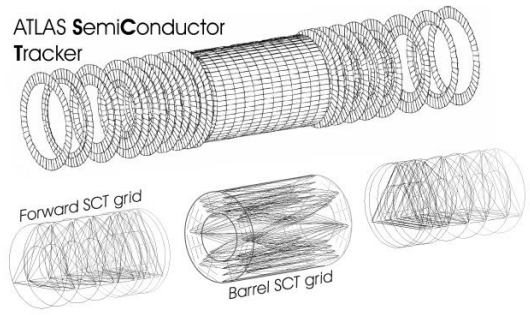
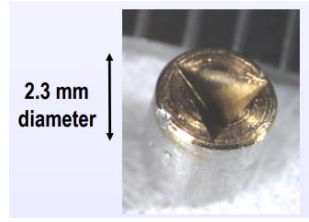
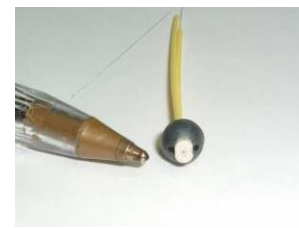
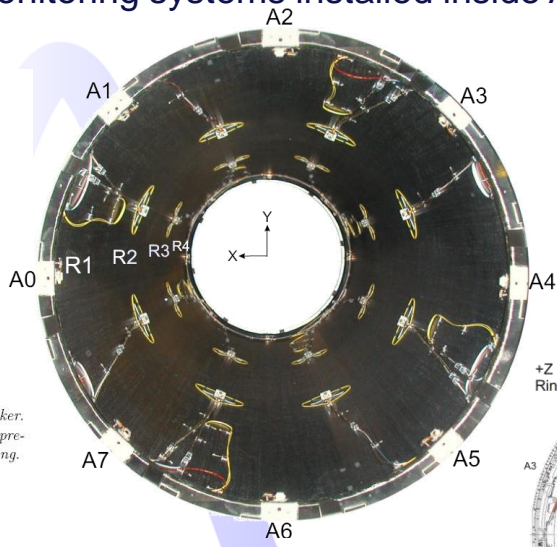

Figure 1: The layout of the silicon detector modules in the ATLAS SemiConductor Tracker. The three SCT sections are monitored using FSI geodetic grids. Each of the 842 lines represents an interferometric distance measurement between grid nodes. The SCT is 5.6m long.



Cf. presentation

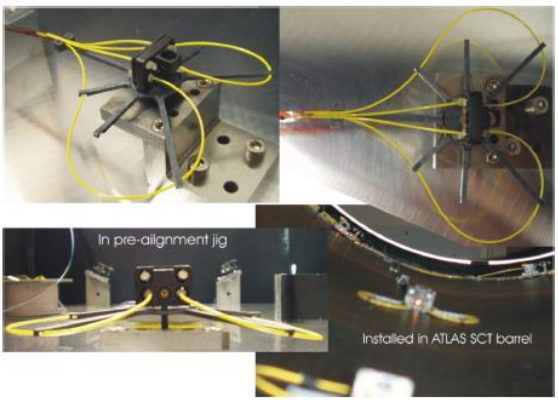

Figure 3: An ATLAS FSI jewel, called a 'scorpion', is pre-aligned in a jig that replicates the layout of the ATLAS SCT barrel.

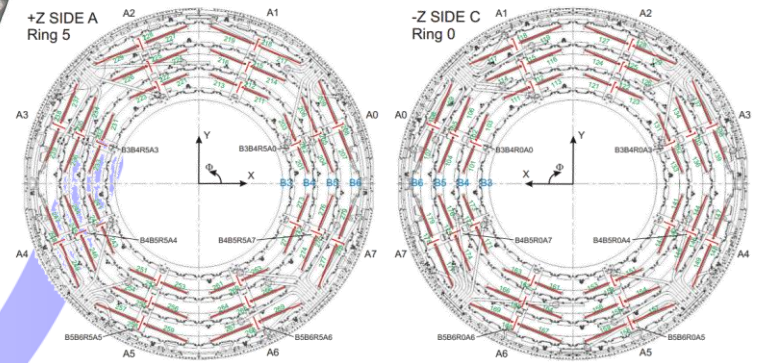
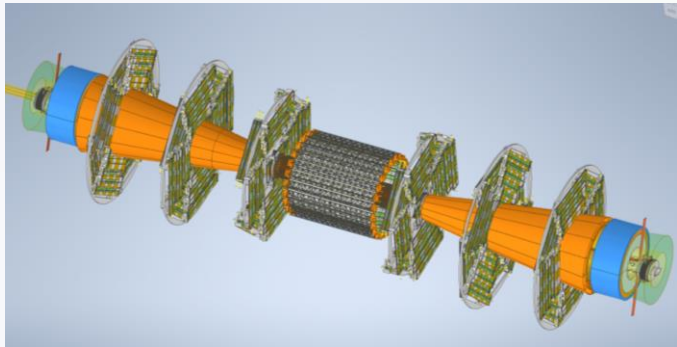

Figure 1: Grid line Interferometer layout on SCT Barrel flanges.

Gibson, S. M., et al. "Monitoring the heart of ATLAS using Frequency Scanning Interferometry." *Proceedings of the Eighth International Workshop on Accelerator Alignment, CERN, Geneva. 2004.*

# Deformation monitoring: simulations ongoing



First simulations ongoing (here, the network of points and points visible from a measuring position):

## Examples of optical systems available :

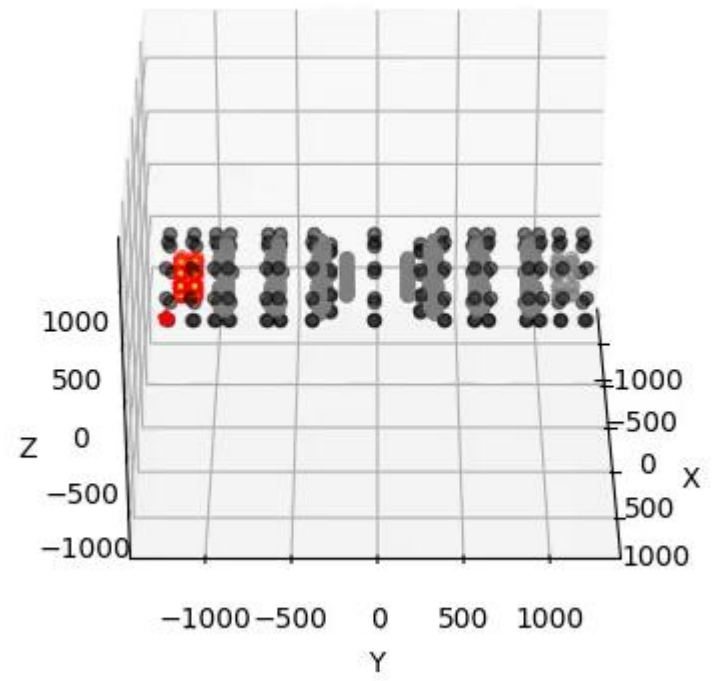
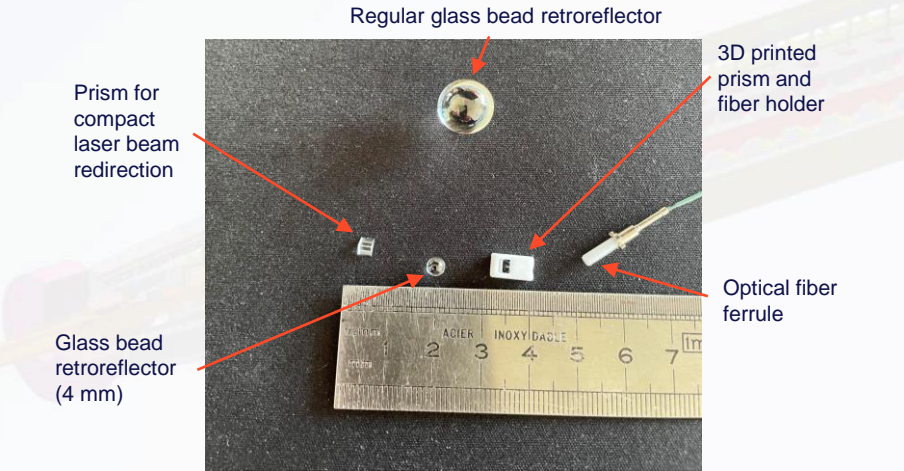

Inner tracker not studied yet



Thank you for your attention

# Recovering the data from the fibers

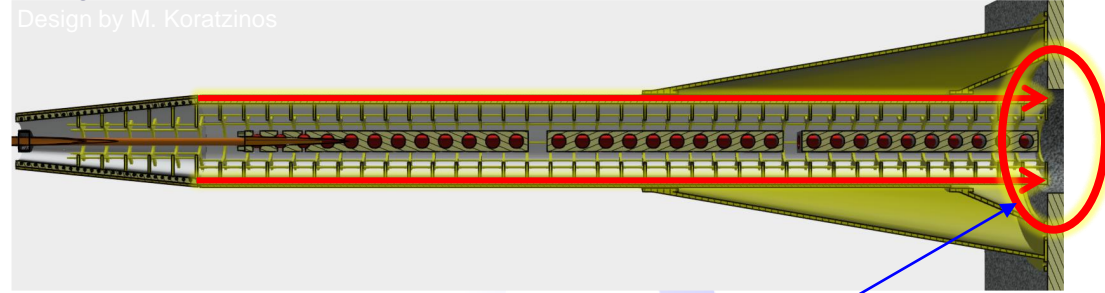

All the information from the fibers will go through there.  
 Challenges due to conditions (space, temperature gradient, radiations, vacuum ...) -> interface with fibers brazed or glued using epoxy.

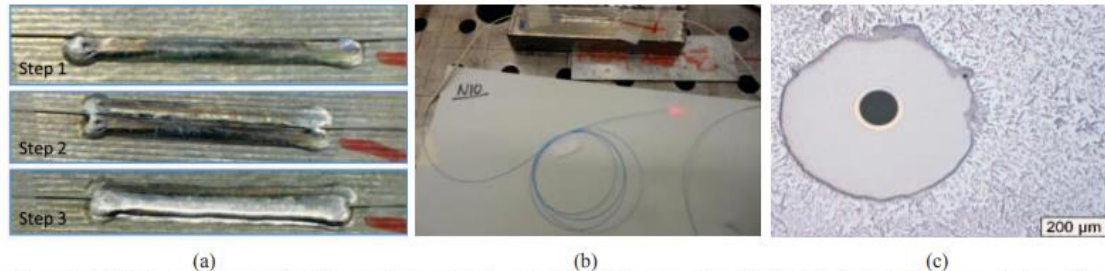
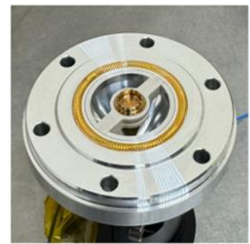

Figure 2. (a) Optimized 3-step embedding technique with laser brazing, (b) setup with red light fault detector for coarse tuning of the embedding technique and (c) cross section cut of the embedded optical fiber in metal using laser brazing.

Grandal, Tania, et al. "Laser brazing metallic embedding technique for fiber optic sensors." 2017 25th Optical Fiber Sensors Conference (OFS). IEEE, 2017.

To be studied

Epoxy glued optical fiber for installation on low-beta quadrupole cryostat for HL-LHC



(b) EO-BPM button assembly, mating view

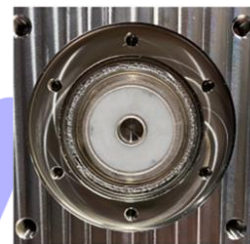

(a) Ceramic washer brazed into the EO-BPM body

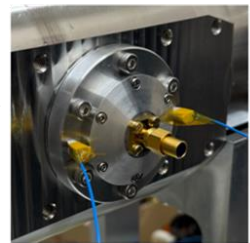

(c) EO-BPM button assembled onto the body

Figure 3: Photos showing detail of the ceramic washer brazed to the EO-BPM body, mating interface to the button assembly and button assembled onto the body.

Bosman, M. Z. C., et al. "DESIGN AND DEPLOYMENT OF AN IN-VACUUM ELECTRO-OPTIC BPM AT THE CERN SPS."

# To put to perspective : subdetector monitoring systems installed inside ATLAS

Lines of sight

device class	type	physical	logical	function
in-plane	RASNIK	1984	1984	MDT deformation
MDT temperature	TEMP	96	768	MDT expansion
in-bar	RASNIK	176	352	bar deformation
bar temperature	TEMP		608	bar expansion
radial	BCAM	96	256	bar deformation
polar	BCAM	208	1856	bar-bar link
azimuthal	BCAM	736	1472	bar-bar link
proximity	RASNIK	2384	1192	MDT-bar and MDT-MDT link
laser source	BCAM	584	2208	MDT-bar link
3D sensor	BCAM	192	384	CSC-bar and CSC-CSC link
CSC temperature	TEMP	16	96	CSC electronics monitoring
<b>total</b>		<b>6648</b>	<b>11176</b>	

**Table 3:** Classes of alignment devices in the endcap system (temperature sensors on MDT chambers other than the Small Wheel and EML1/EMS1 ones are not read out by the LW-DAQ system and have been omitted). The "physical devices" column lists the number of LWDAQ devices; the "logical devices" column lists the number of acquired sensor images or temperatures, respectively. The device classes and their functions are described in section 3.

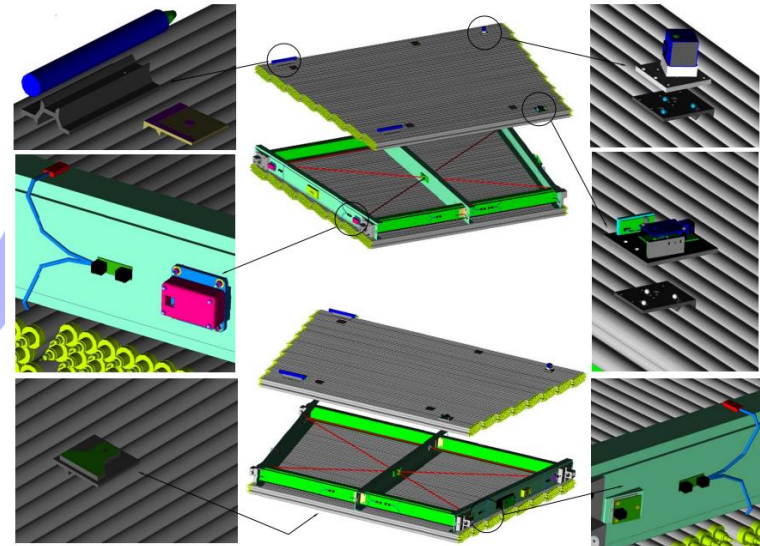
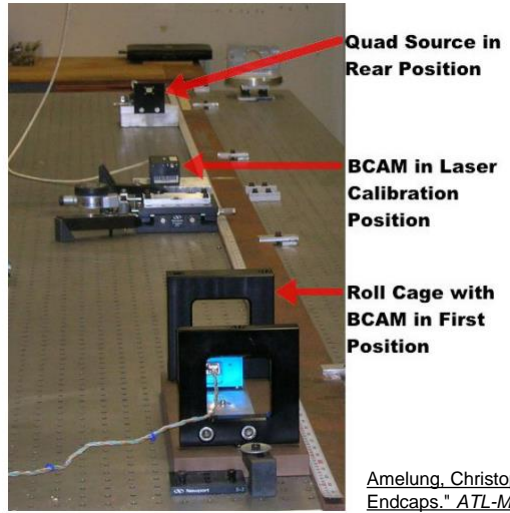
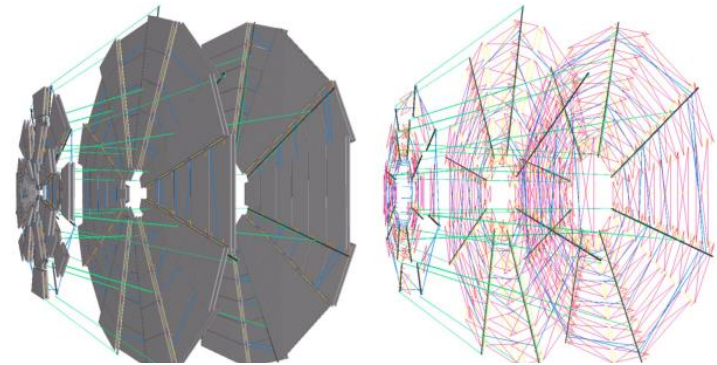

Amelung, Christoph, et al. "The Optical Alignment System of the ATLAS Muon Spectrometer Endcaps." *ATL-MUON-PUB-2008-003* (2008).

## Re-adjustment system

- Interest of having a system able to move one or multiple element without requiring to disassemble the entire QC1 ?
- Not necessary to be accurate at 10  $\mu\text{m}$ , a system able to correct major displacements  $\sim 0.2\text{ mm}$  to 1mm (due to transport, gravity deformation, movement during cool down, intense magnetic fields ...) would be already extremely convenient.
- Not necessary to work at cryogenic temperatures only at room temperature would be already extremely convenient.
- Not necessary to be able to work during the run of the machine, during shut downs would be already extremely convenient.

A lot of possibilities are open, from the system working only at warm temperature allowing a re-adjustment to the 0,1mm level of major components at the end of shut downs, to the system able to realign in real time and during the run of the machine the cold components to the micrometer level.

Systems to work in these conditions exist, the difficulty is to quantify their advantage compared to a loss of luminosity due to any misquantified misalignment value or to the need to dismount, disassemble, realign, reassemble and remount the assembly.

The EUCLID VIS Read-out Shutter Unit, which will operate in space

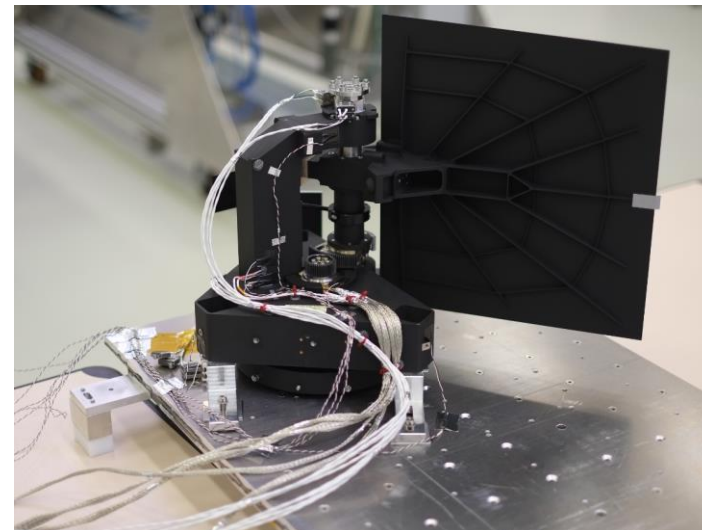

Larchevêque, C., et al. "The Euclid VIS read-out shutter unit: a low disturbance mechanism at cryogenic temperature." *arXiv preprint arXiv:1801.07496* (2018).



Universal Alignment Platform Tests, Kacper Widuch, Vivien Rude BE-GM-HPA 2021-03-11