

# FCC ELECTRICAL GRID AND INFRASTRUCTURE UPDATE

FCC Week – 20<sup>th</sup> May 2025  
Charline MARCEL (CERN-EN/EL)

# Outline

- **Overall concept of the electrical grid defined for the Feasibility Study**
- **Feasibility study of the HV lines**
- **Electrical infrastructure layout**
- **Secured network concept**
- **Next steps for the pre-TDR phase**

# Overall concept of the electrical grid defined for the Feasibility Study

## Energy consumption of the FCC-ee machine

Power demand by systems in MW:

	Z	W	H	t $\bar{t}$
Beam energy, GeV	45.6	80	120	182.5
Collider radiofrequency	146	146	146	146
Booster radiofrequency	2	2	2	2
Collider cryogenics	1.2	11.5	11.5	27.6
Booster cryogenics	0.35	0.8	1.5	7.4
Cooling and ventilation	25	26	28	33
Collider magnets	6	17	39	89
Booster magnets	1	3	5	11
4 experiments, PA, PD, PG, PJ	10	10	10	10
4 datacenters, PA, PD, PG, PJ	4	4	4	4
General services	26	26	26	26
<b>Total power during beam operation</b>	<b>222</b>	<b>247</b>	<b>273</b>	<b>357</b>

Load mapping of the machine:

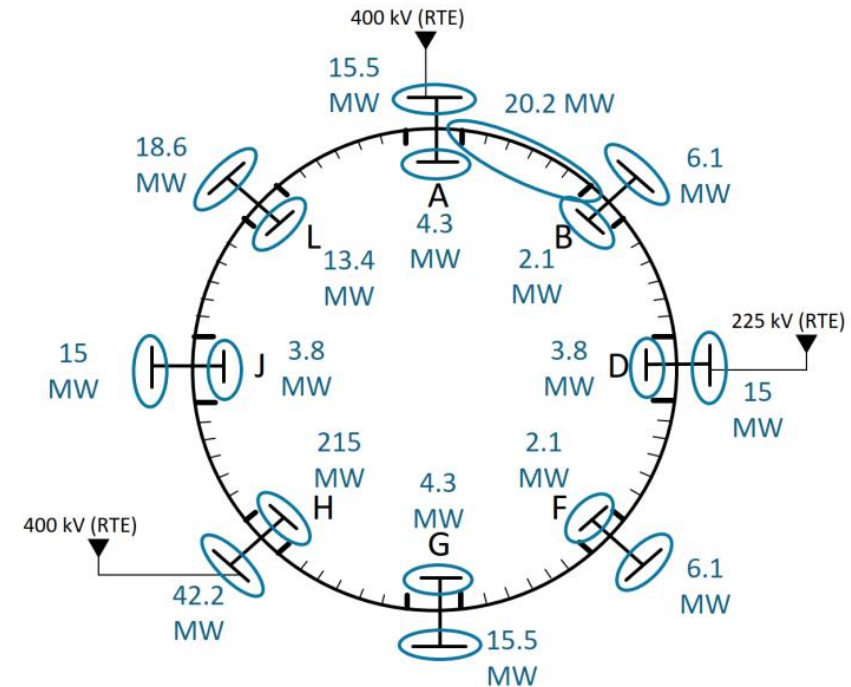

# Overall concept of the electrical grid defined for the Feasibility Study

## Energy consumption of the FCC-ee machine

Operation modes:

Period Type	Duration
Shutdown	120 days
Commissioning	30 days
Physics Operation	185 days
Beam colliding	139 days
Downtime	46 days
Machine development	20 days
Technical Stops	10 days

Power demand by operation modes in MW:

Beam energy mode	Z	W	H	$t\bar{t}$
Shutdown	30	33	34	41
Technical stop	67	78	81	108
Short downtime	74	98	125	209
Commissioning	144	163	177	233
Machine Development	96	121	147	231
Beam operation	222	247	273	357



Energy consumption between **1,07 TWh (Z mode)** and **1,77 TWh ( $t\bar{t}$  mode)**

# Overall concept of the electrical grid defined for the Feasibility Study

## Grid connections and transmission network

- 3 connections to RTE (French Electricity Transmission Network) at 400 or 225 kV
- All points connected to local grid at 20 or 18 kV for, first works phase, then back-up sources
- HV lines, passing through the tunnel, between all HV substations on surface, designed to allow reconfigurations
- HV internal network at 63 kV

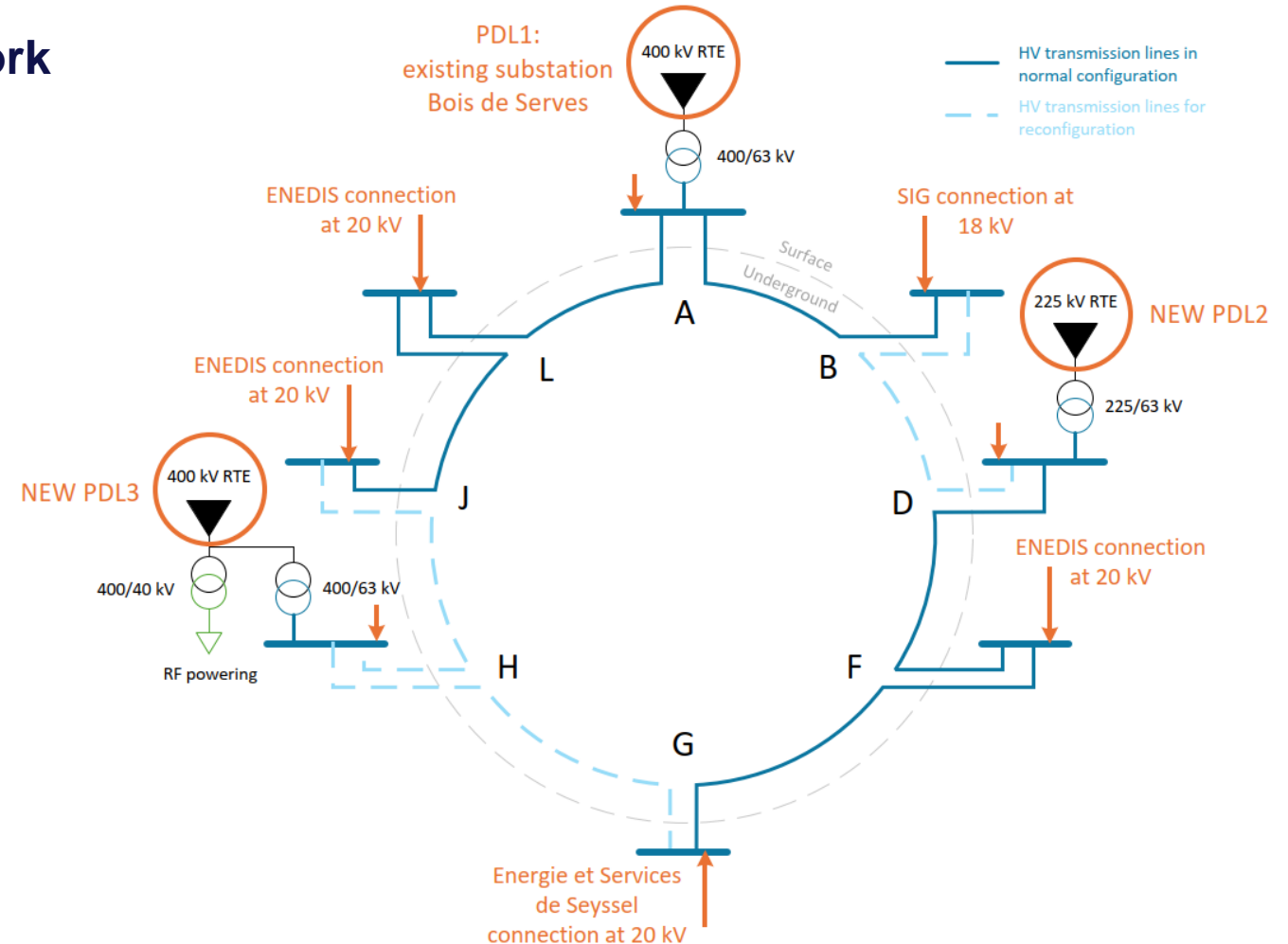

# Overall concept of the electrical grid defined for the Feasibility Study

## Grid connections and transmission network

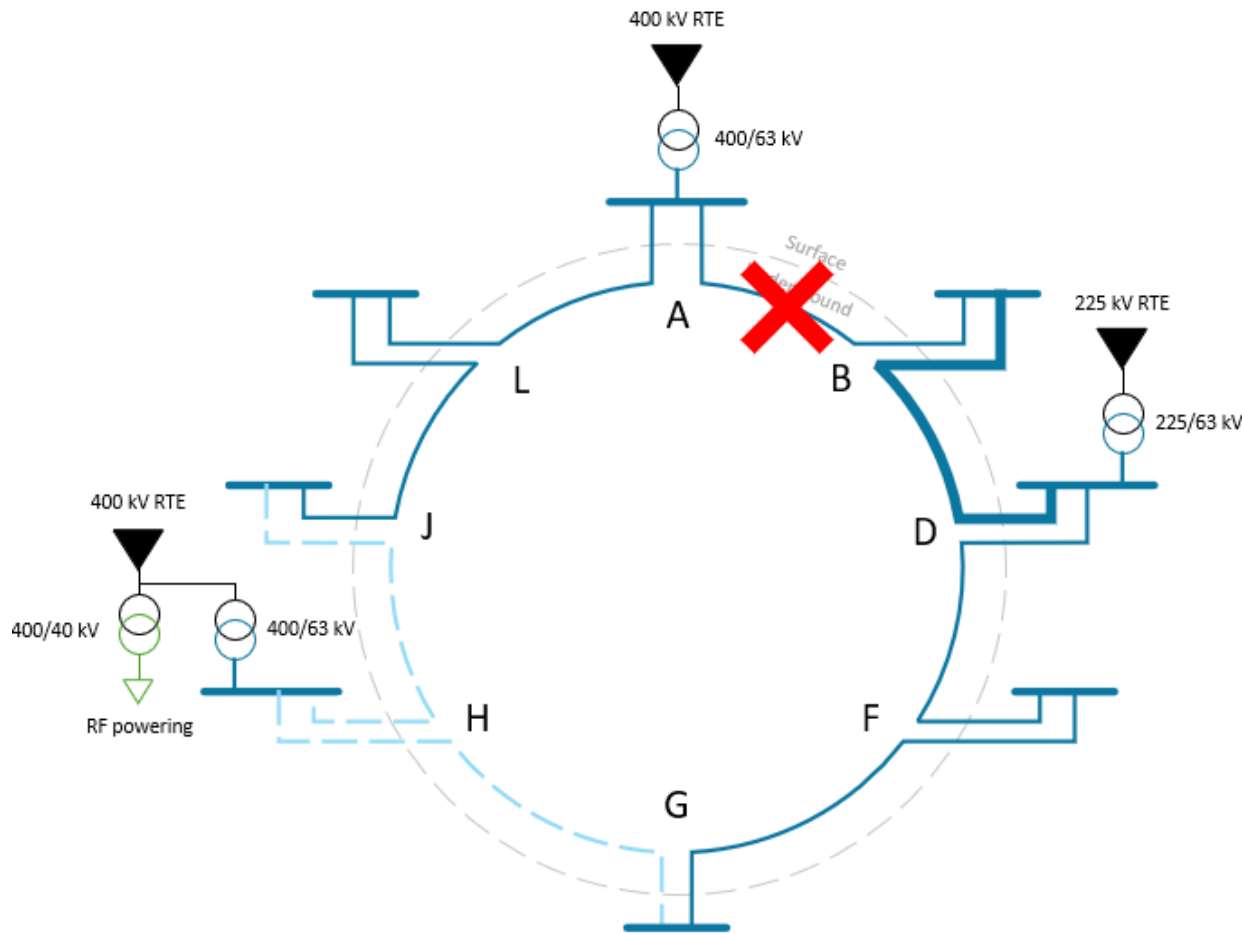

**Loss of the line PA – PB:**  
 Reconfiguration by activating  
 the line PD – PB  
 The machine can normally work

➔ The HV lines must be designed at 115 MVA to allow normal operation for the loss of any lines or source of PA & PD

# Overall concept of the electrical grid defined for the Feasibility Study

## Grid connections and transmission network

### Optimization study:

- Based on CAPEX/OPEX over the total lifetime of FCC
- Including HV lines and substations
- For different scenarios:
  - High voltage level: 63, 90 & 132 kV
  - Substations technology and location: AIS or GIS, on surface or underground

**Baseline: 63 kV with GIS on surface**

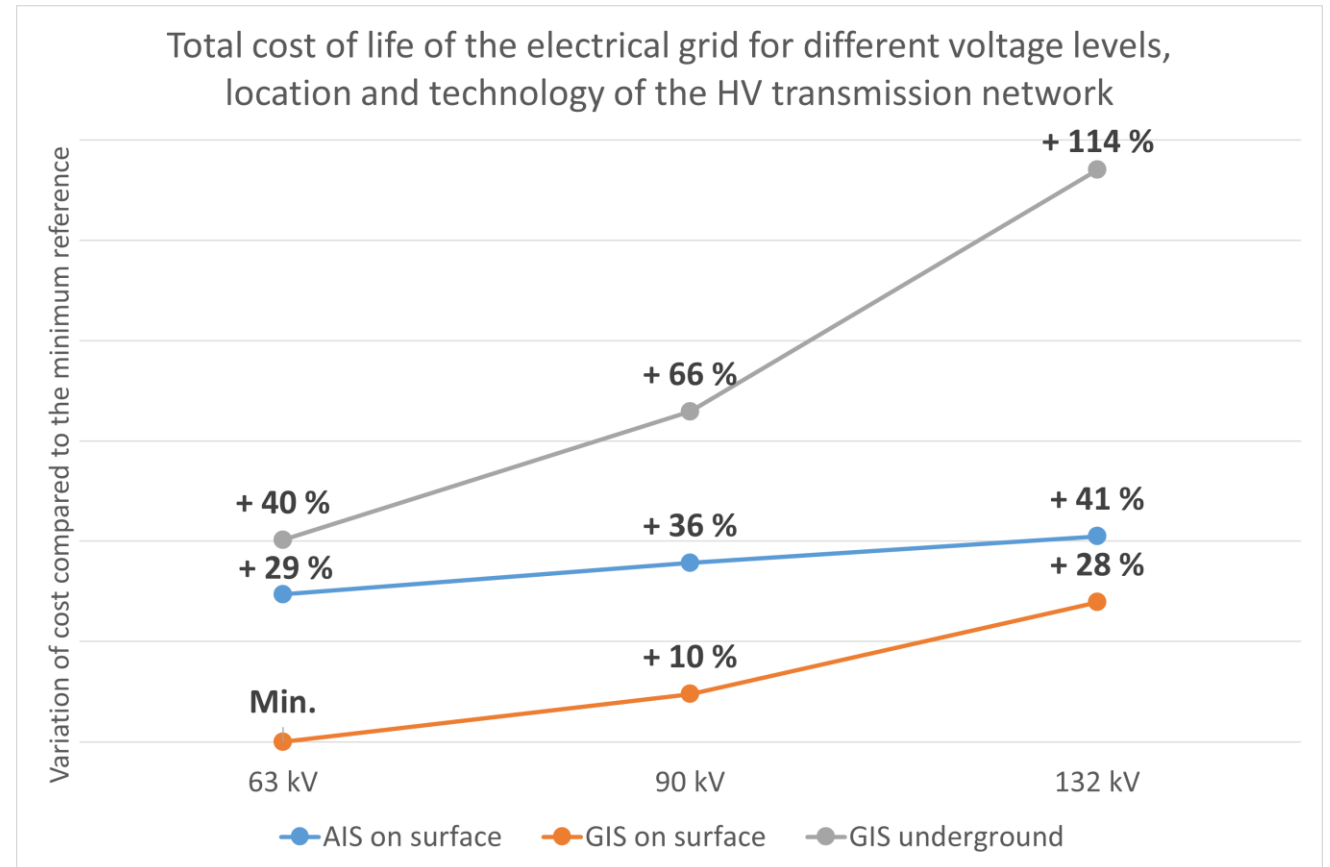

# Feasibility study on the HV lines

**Consulting study realized in 2024 to verify the feasibility of installing an HV line between surface substations of access points through the tunnel**

Definition of:

- Requirements of the installation of an HV line in the tunnel, shafts, service caverns, surface galleries and zones in between
- Design of the HV line: HV cables with a power flow defined, accessories, earthing, impact on the environment
- Design of the junction chambers: needs, quantities and layout
- Installation process and needs
- Cost and timelines of installation
- Maintenance and reparation requirements

**Feasibility  
confirmed**

Report foundable on EDMS: <https://edms.cern.ch/document/3170168/1>  
58 pages, in French



# Feasibility study on the HV lines

## Main outcomes of the study

### Space requirements:

- In the arc: HV cables in PEHD ducts buried in a 520 x 500 mm concrete block

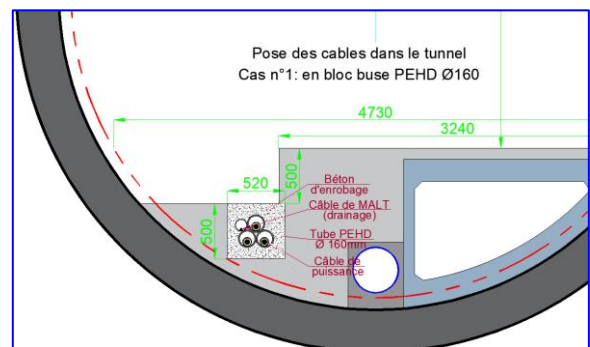

- In the alcove area: one 1,5 x 9,5 m junction chamber to be installed at each alcove

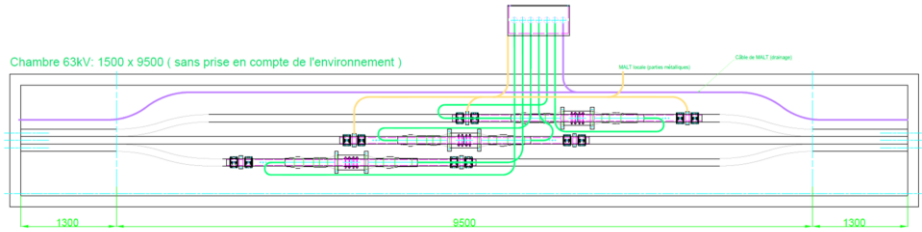
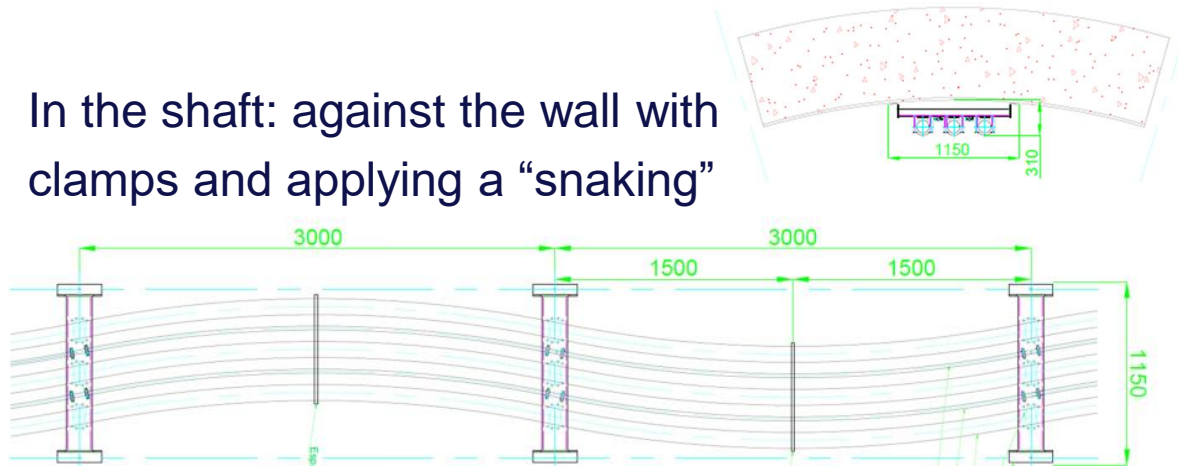

Figure 25 - Plan type d'une chambre 63kV avec jonctions étagées et mise à la terre des écrans (plan of a 63kV joint bay with stepped joints and earthing of screens)

- In the shaft: against the wall with clamps and applying a "snaking"



- Areas in between for cable routing: 2,34 m bending radius while pulling, 1,56 m bending radius when installed

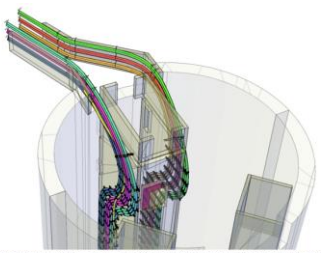

Figure 9 - Illustration d'un exemple de transition entre une pose en galerie et une descente en puits (Illustration of an example of the transition between a tunnel laying and a shaft descent)

## Cost and timelines:

- Total of 6,4 M€
  - 160 days of installation
- } per 12 km section

# Electrical infrastructure layout

Estimation of the electrical equipment requirements across various underground facilities

Example given: PH

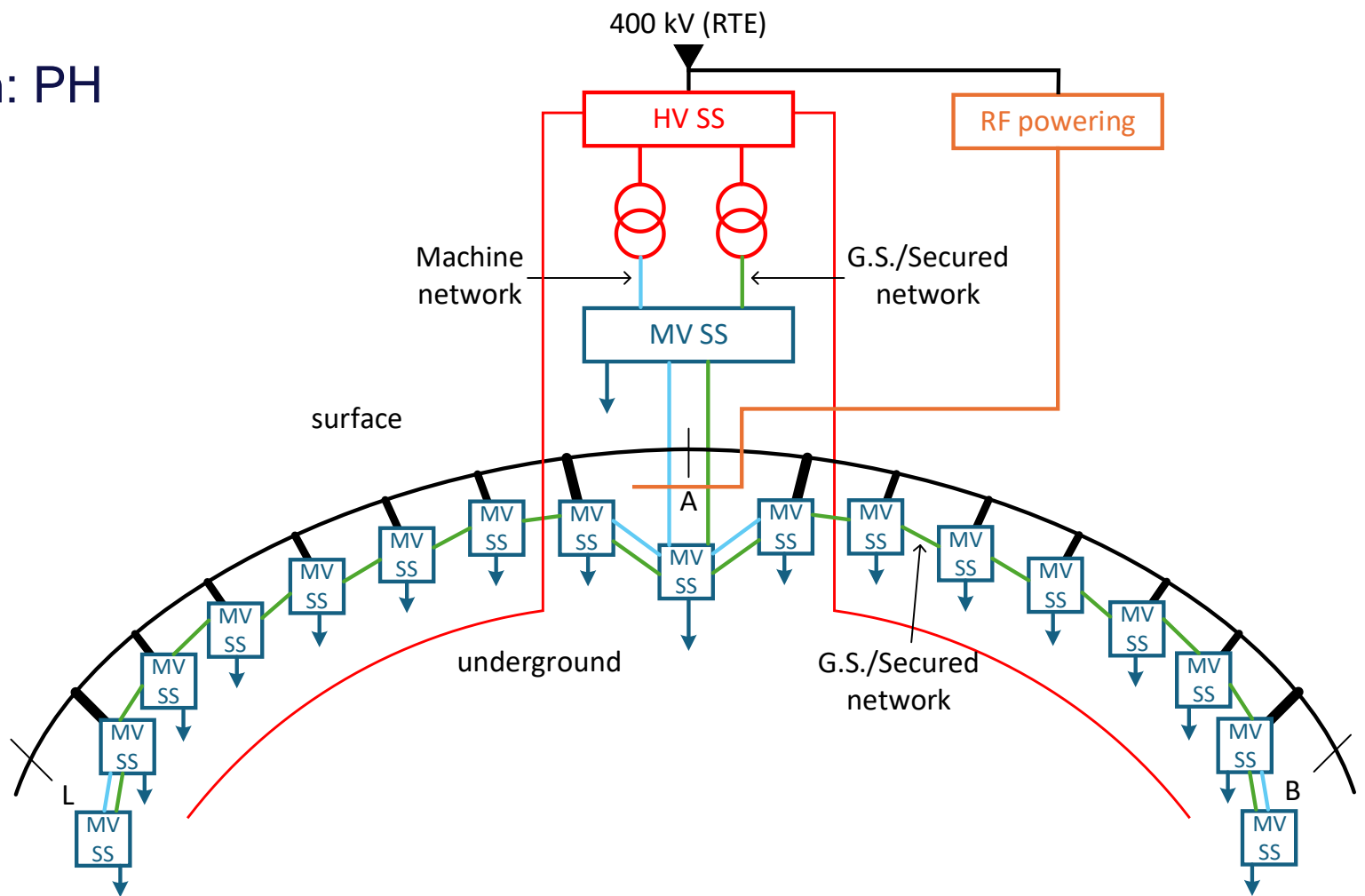

# Electrical infrastructure layout

Estimation of the electrical equipment requirements across various underground facilities

Example given: PH underground

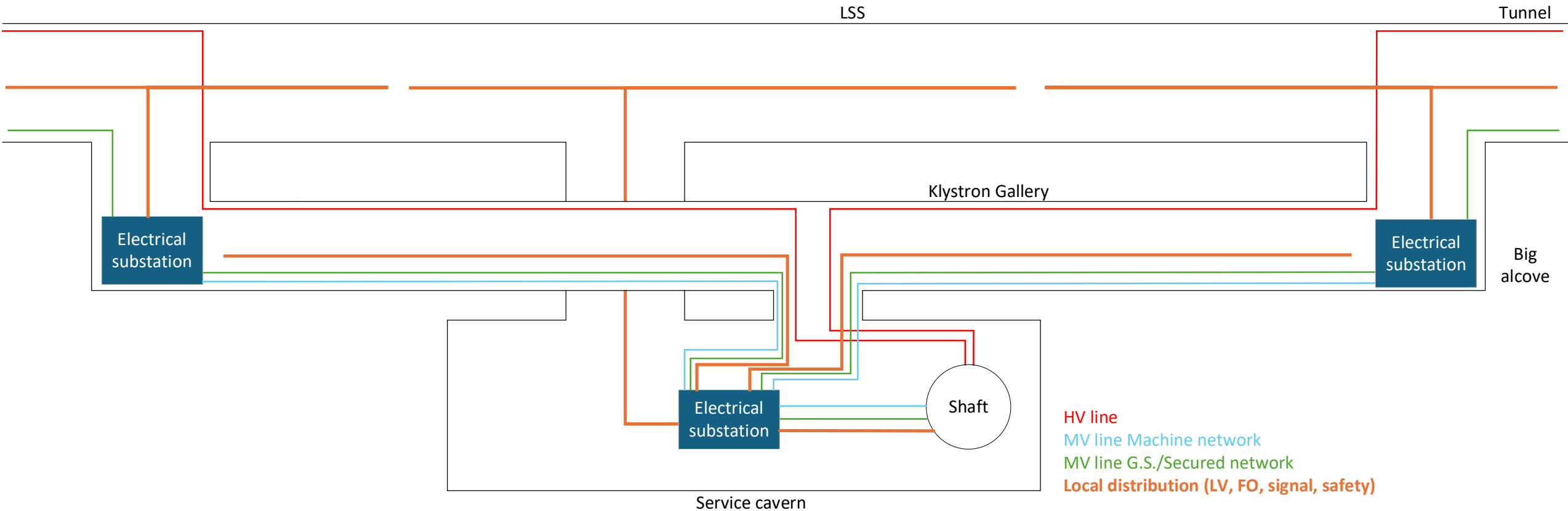

# Electrical infrastructure layout

Estimation of the electrical equipment requirements across various underground facilities

Example given: PH klystron gallery

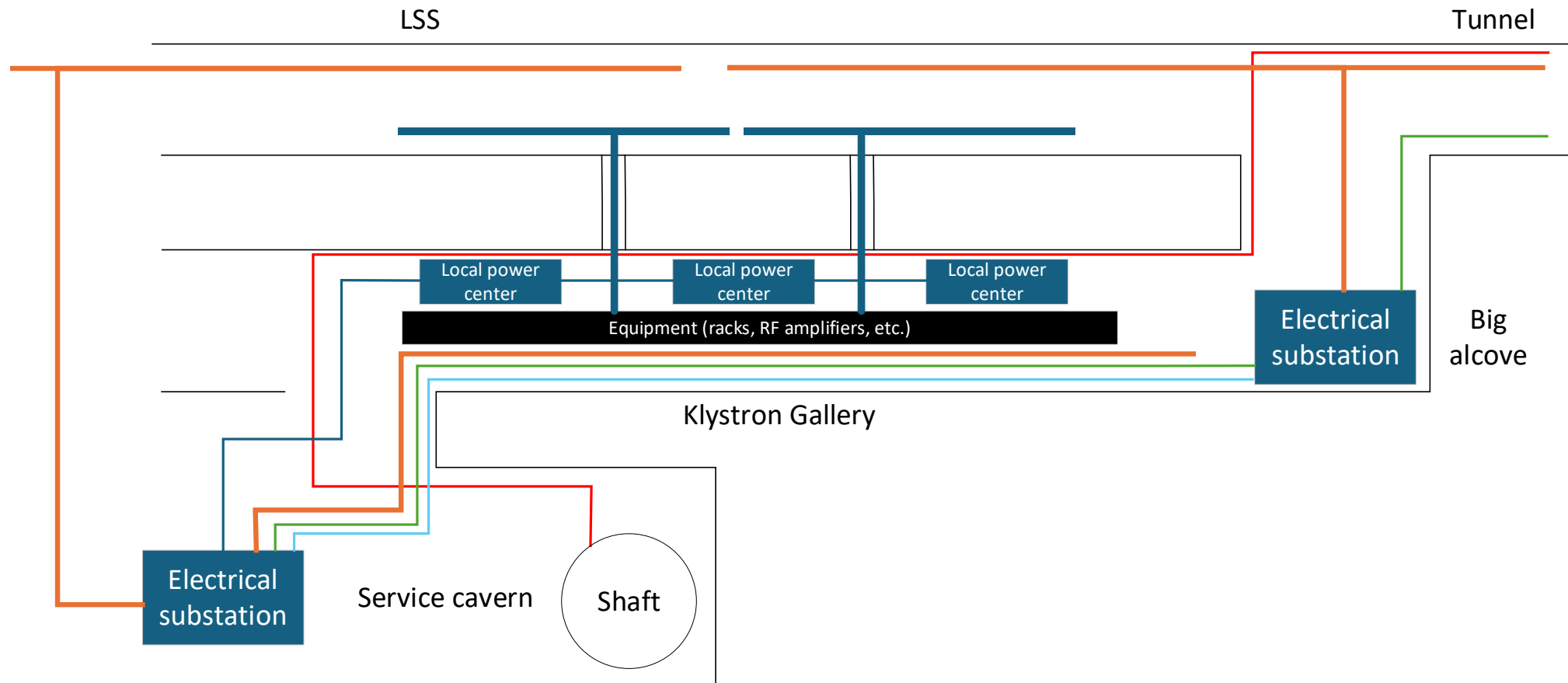

# Electrical infrastructure layout

## Estimation of the electrical equipment requirements across various underground facilities

Example given: PH underground

**Electrical substation in the service cavern:**      **In big alcoves:**

Equipment	Number	Total footprint (width x depth cm)	Require access at back and front?
MV cubicles G.S. network	6	360x100 (60x100 each)	Yes
MV cubicles Secured network	6	360x100 (60x100 each)	Yes
MV cubicles Machine network	8	480x100 (60x100 each)	Yes
2 MVA transformer G.S. network	1	270x160	Yes
2 MVA transformer Secured network	1	270x160	Yes
LV switchboard for G.S. network	1	500x100	Yes
LV switchboard for Secured network	1	500x100	Yes
Racks for G.S. & Machine networks (including 48 Vdc systems)	9	540x80 (60x80 each)	Yes
Racks for Secured network (including 48 Vdc systems)	7	420x80 (60x80 each)	Yes

Equipment	Quantities	Total footprint (width x depth cm)	Require access at back and front?
MV cubicles G.S. network	3	180x100 (60x100 each)	Yes
MV cubicles Secured network	3	180x100 (60x100 each)	Yes
MV cubicles Machine network	6	360x100 (60x100 each)	Yes
800 kVA transformer G.S.	1	230x150	Yes
630 kVA transformer Secured	1	200x140	Yes
2 MVA transformer Machine	1	270x159	Yes
LV switchboard for G.S.	1	240x60	Yes
LV switchboard for Secured	1	240x60	Yes
LV switchboard for Machine	1	400x100	Yes
UPS systems	2	320x80 (160x80 each)	Yes
CPS system	2	120x80 (60x80 each)	Yes
Control & fibre optic racks	3	180x80 (60x80 each)	Yes

**+ Cable tray needs in the different tunnels**

# Secured network concept

## From distribution network concept

- Nominal mode: two MV networks for each point (machine and general services). Each point supplies **half sector**.
- For each point: Possible **mutual re-supply in surface**.
- For each point: Possible **mutual re-supply in underground**.
- Possible re-supply of the **full sector from one point**.

**Per point:**  
 2x 40 MVA HV/MV transformers  
 Main MV links rated 20 MVA  
 Tunnel MV links rated 14 MVA

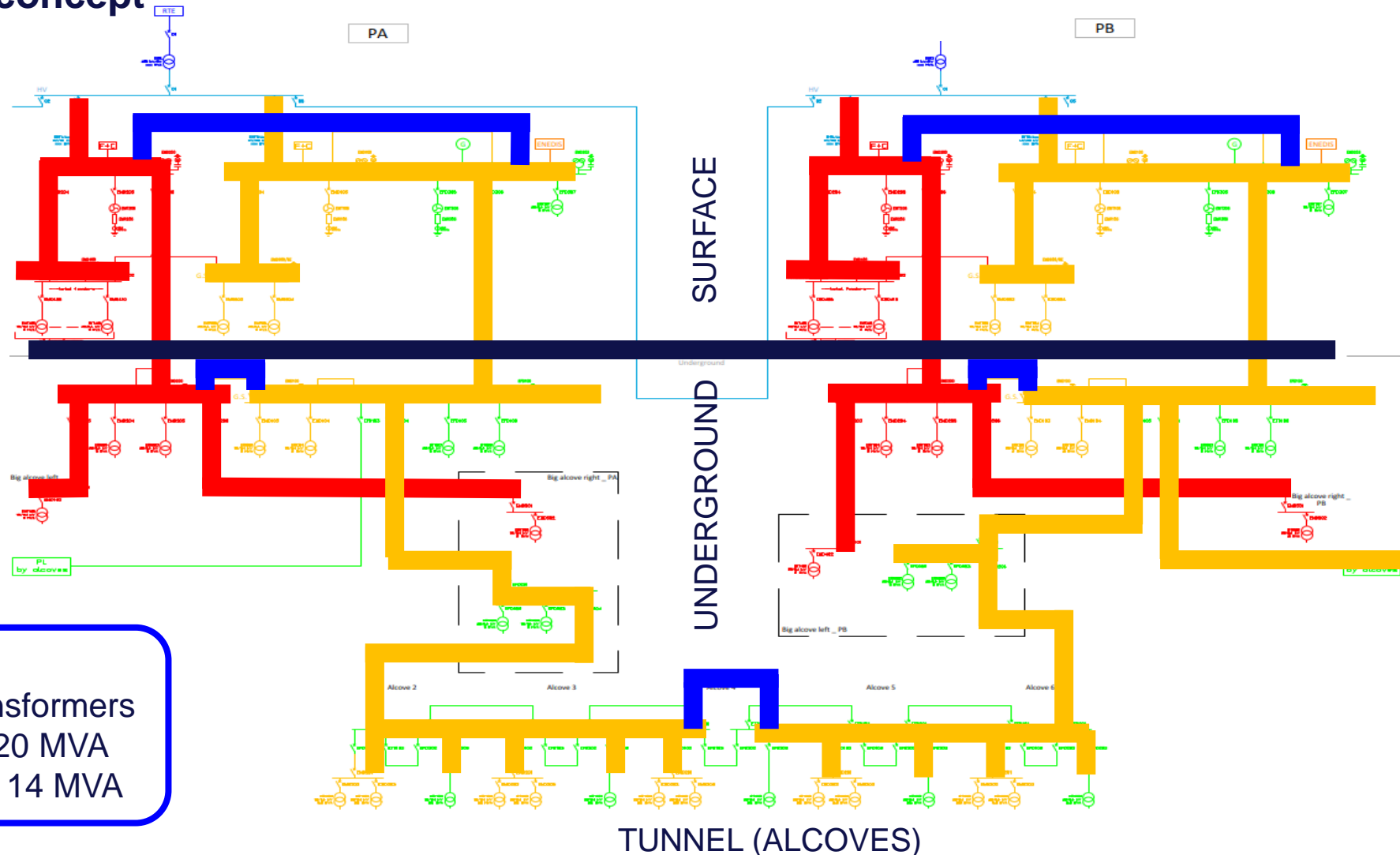

TUNNEL (ALCOVES)

# Secured network concept

## To an optimized secured network concept

- **Two backups** per point for MV (20 kV) power supply:
  - Gensets & local public utility
- **Same links for normal and secured networks**
  - Load-shedding
  - High maintainability
- **Two networks arriving in all the alcoves** (from the two points)
  - Possibility to **re-supply from the adjacent point** in case of maintenance or major fault on the sources
- **Challenges:**
  - Fire-resistance of MV infrastructure
  - Opportunity: protection through the civil works (ducts)

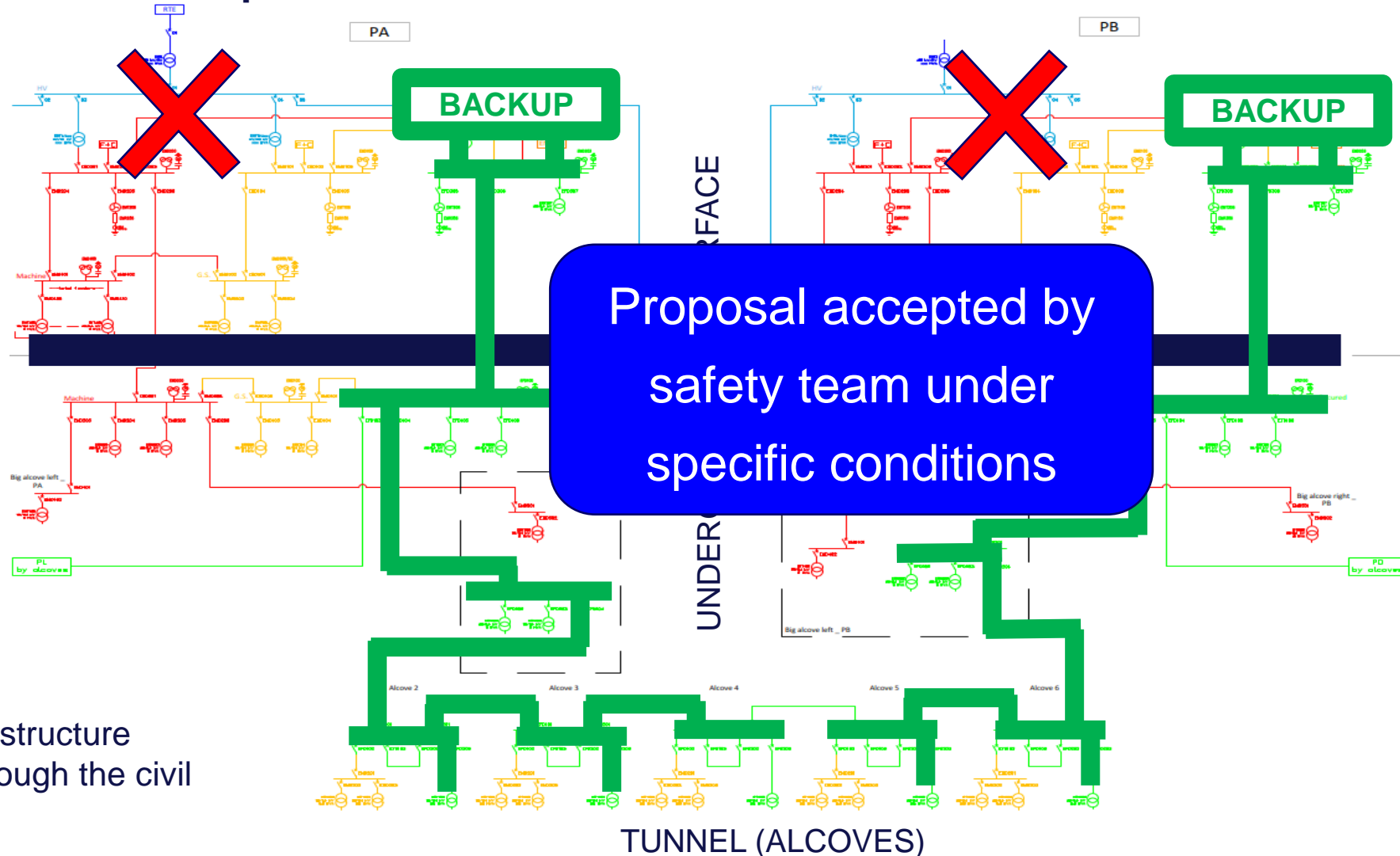

# Next steps for the pre-TDR phase

## Main goals

- Define the space reservations to prepare the civil engineering (underground areas):
  - Reserve space for electrical equipment in the integration
  - Reserve space for cable trays in the integration
- Detail the electrical grid
  - **Update and increase the accuracy of the load requirements and cable needs estimates**
  - **Detail the transmission network and grid connections**
  - **Detail the distribution networks, including the secured network requirements**
- Study systems and solutions to improve efficiency and sustainability of the network
- Study systems and solutions for the network and voltage stability and for power quality
- Study systems and technologies to optimize installation and maintenance
- Develop CAPEX/OPEX optimizations

Looking for a reliable solution to collect, store and follow up users' requirements







Thanks for your attention.  
Questions?