

# FCC-EE CRYOGENICS STATUS UPDATE FROM FSR

*Exploring the cryogenic system design and changes made in the Feasibility Study Report.*

Anita Petrovic, Laurent Delprat, Boyan-Kaloyanov Naydenov Popov, Benjamin Bradu

# Table of contents

## 1. What is FCC?

## 2. Baseline Changes

- RPO
- Heat Loads

## 3. Cryogenic System Changes

- Cooling Capacity
- Cryoplant Architecture
- Electrical Power
- Cryogenic Distribution Line
- Helium Inventory

## 4. Conclusion

# What is FCC?

LHC	FCC
27 km Tunnel	90.7 km Tunnel
~100 m depth	~200 m average depth

Purpose
Precise measurements of Standard-Model particles
Higher energy collisions with broad discovery potential

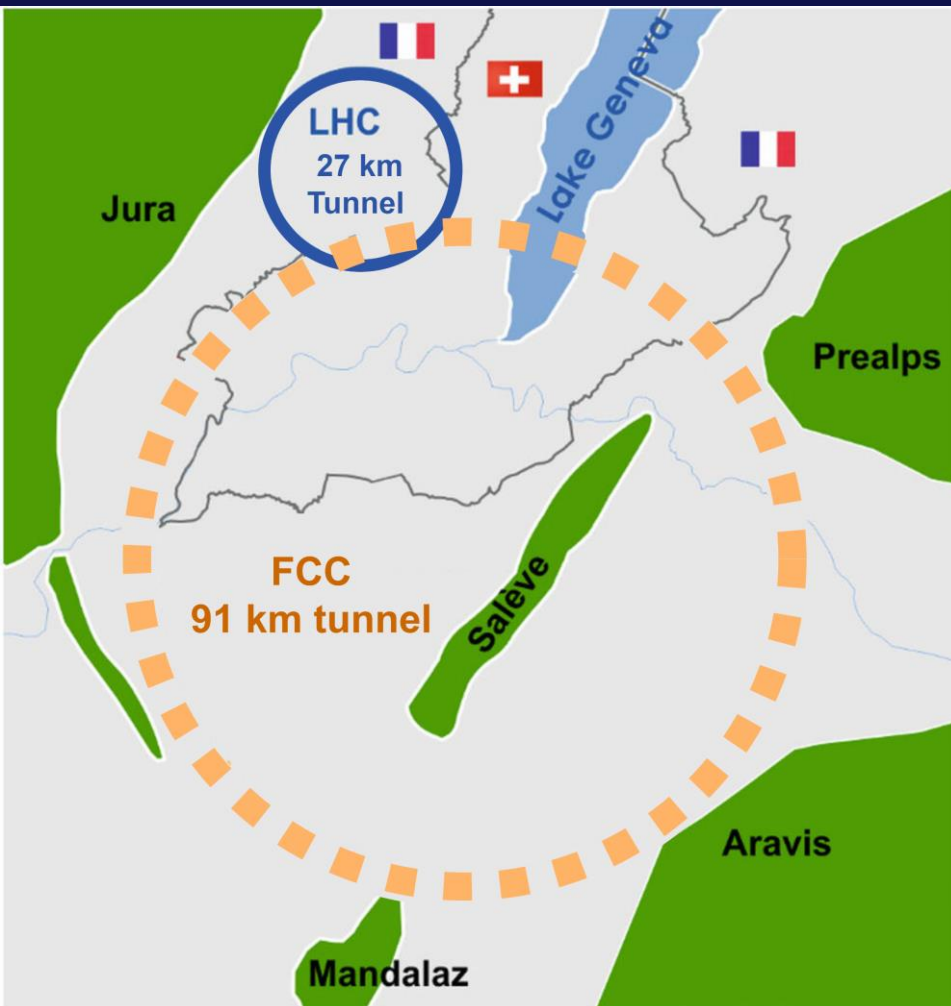

# What is FCC?

FCC-ee	FCC-hh
<b>Operation start: Mid 2040s</b>	<b>Operation start: 2070s</b>
Electron – Positron Collider	Hadron-Hadron Collider
Similar to LEP (Large Electron-Positron Collider)	Upgrade to the LHC
<b>Higher luminosity and precision for electroweak and Higgs physics</b>	<b>Very broad discovery potential</b>

**FCC**  
**91 km tunnel**

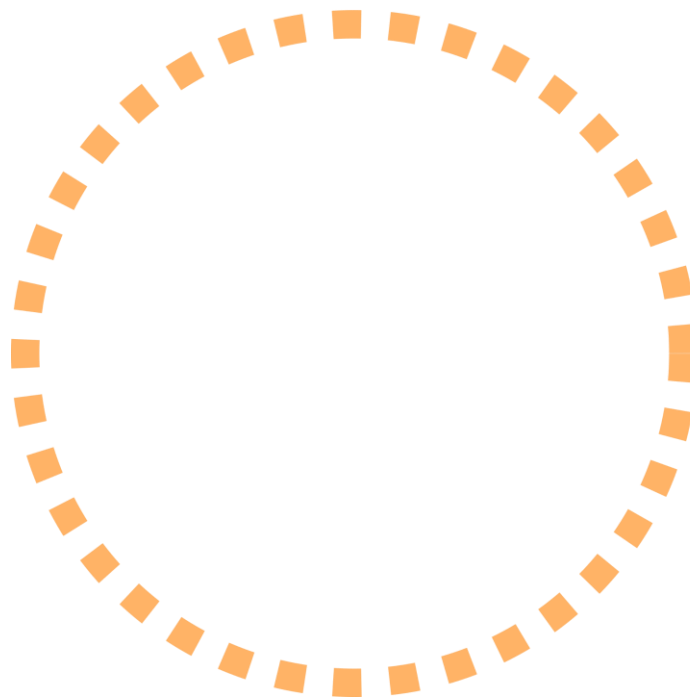

# Status Update

**2025:** FCC Feasibility Study completion and beginning of Pre-TDR phase

→ Refine the design foreseen in the Feasibility Study with industrial partners

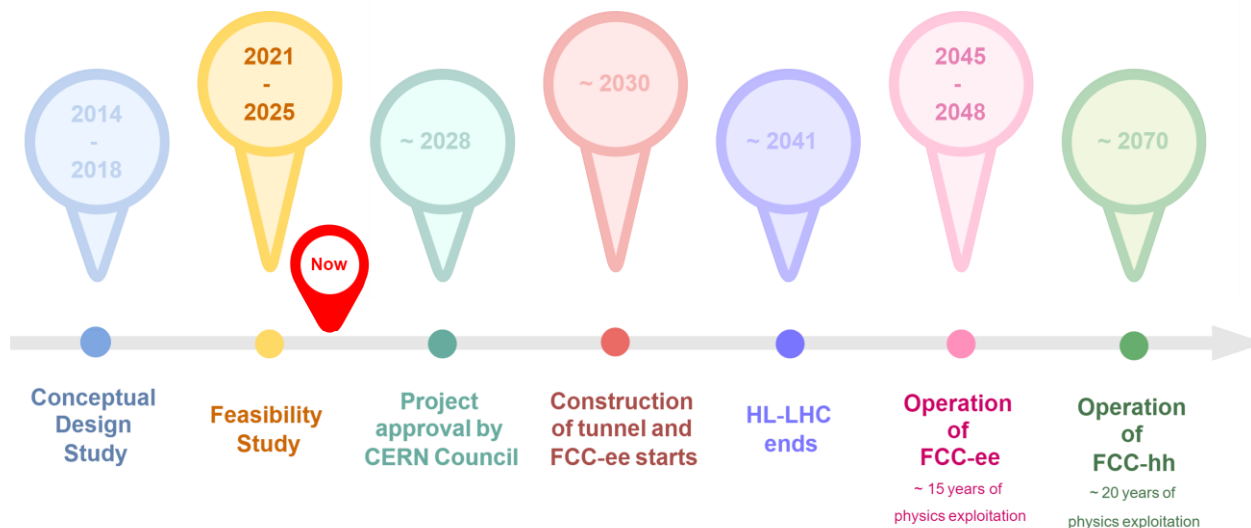

# Status Update

2028: Decision by the CERN member states

→ Launch the civil engineering procurement right after the approval in 2028

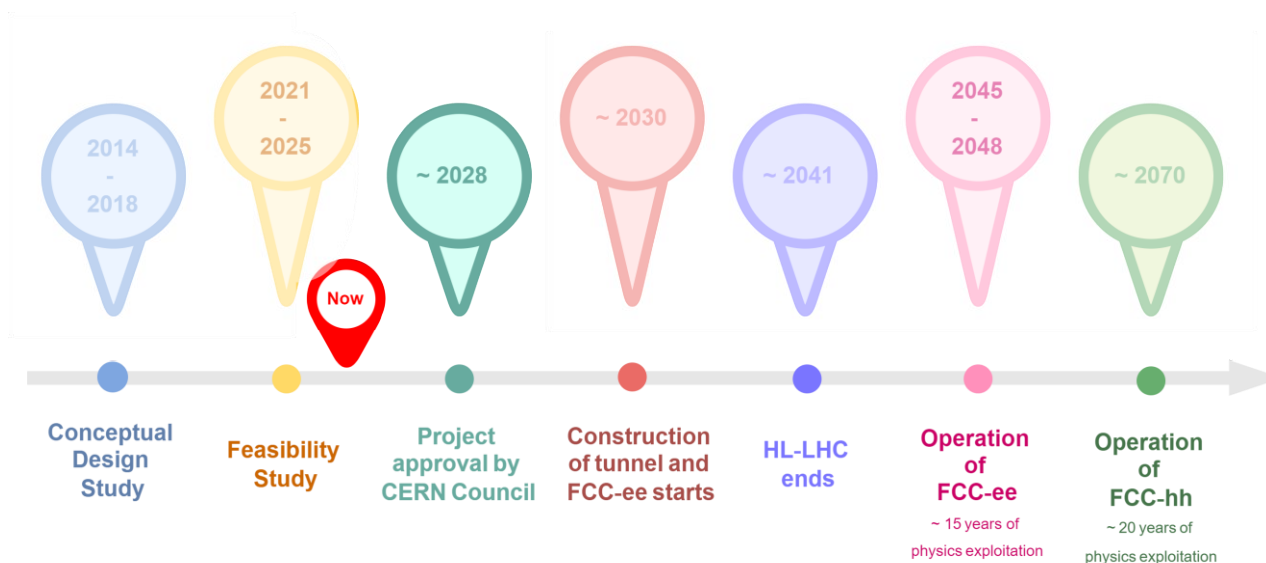

# FCC – ee Cryogenics

(Mid 2040s)



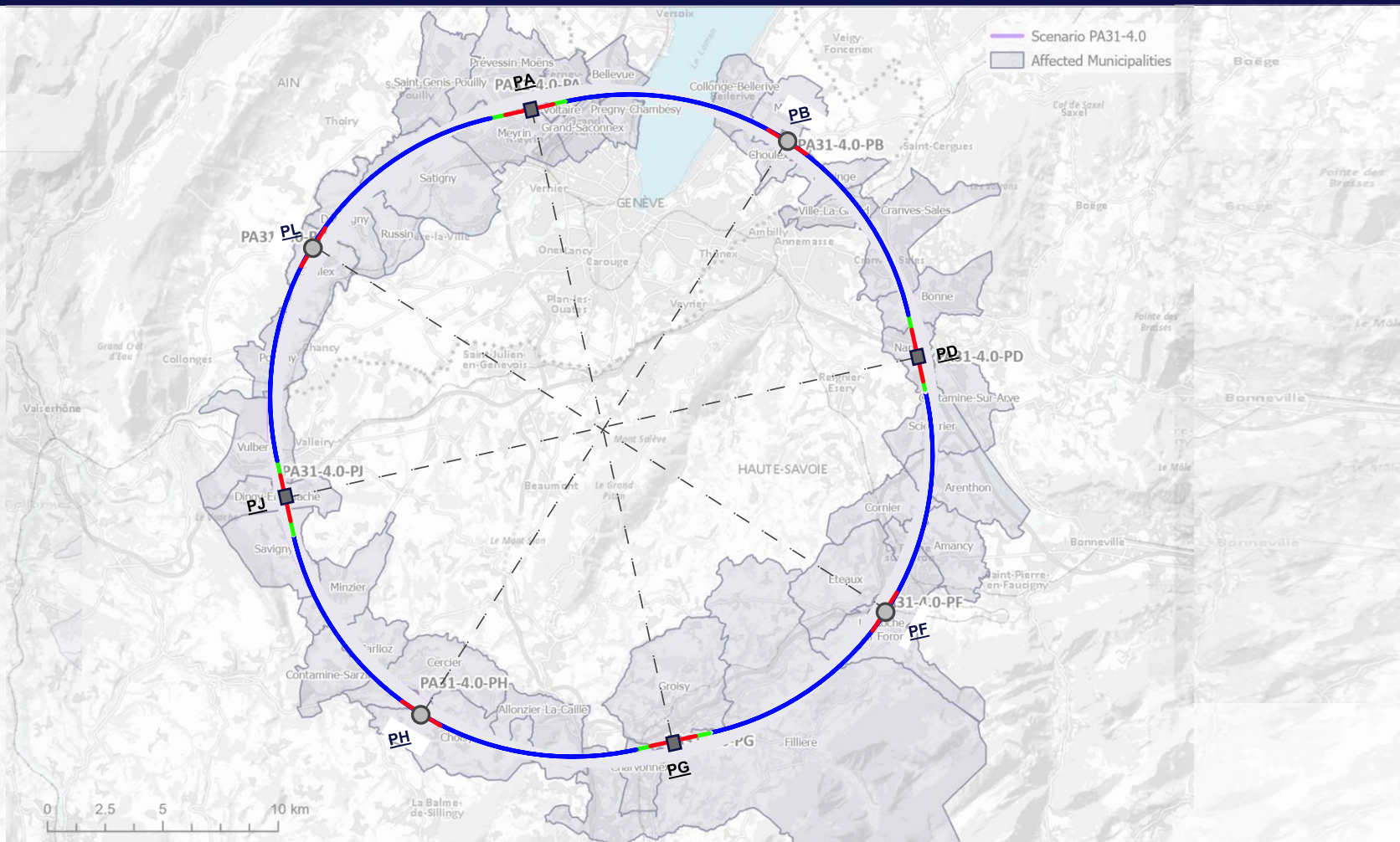

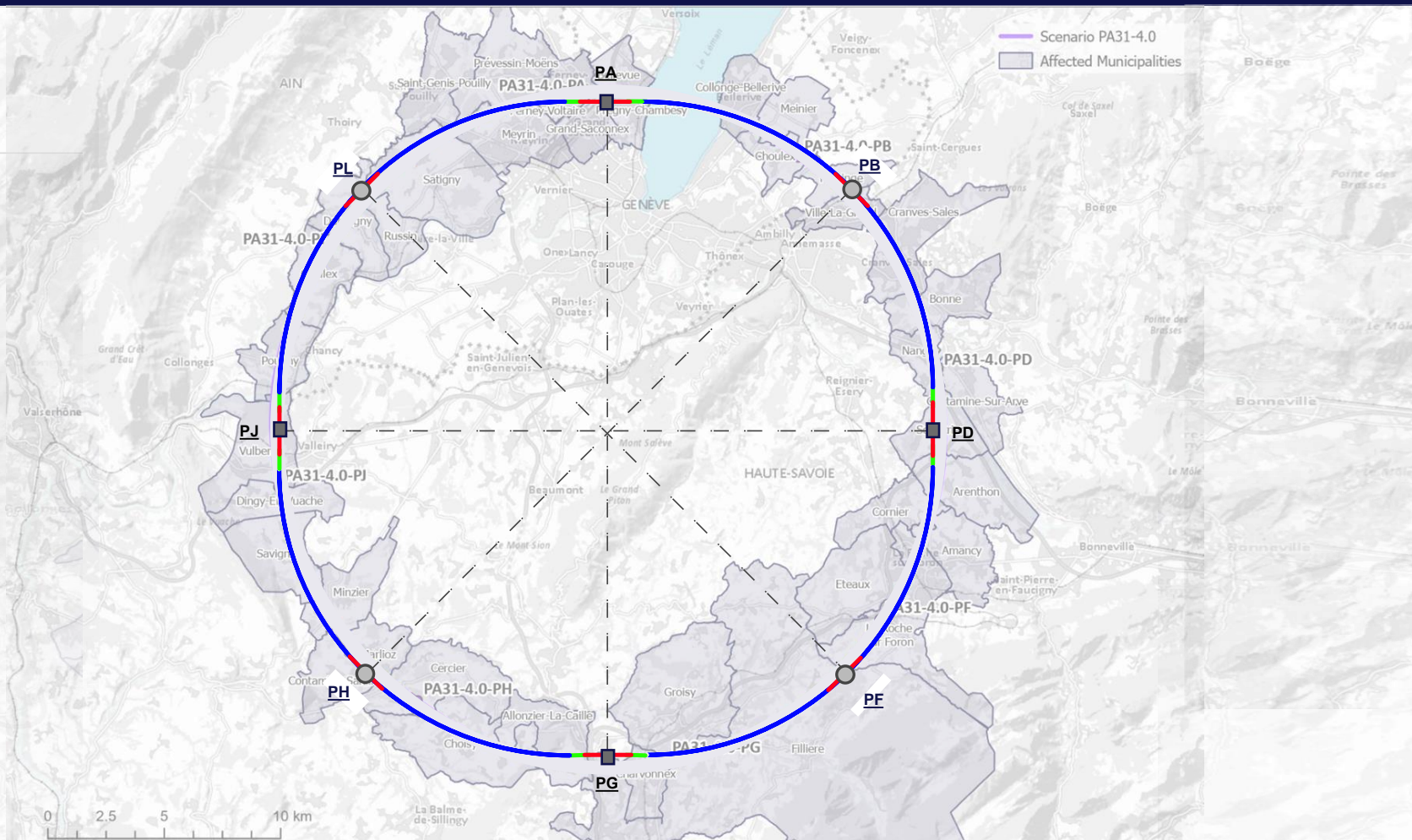

FCC-ee collider cryogenic system layout for  $\bar{t}t$  operation

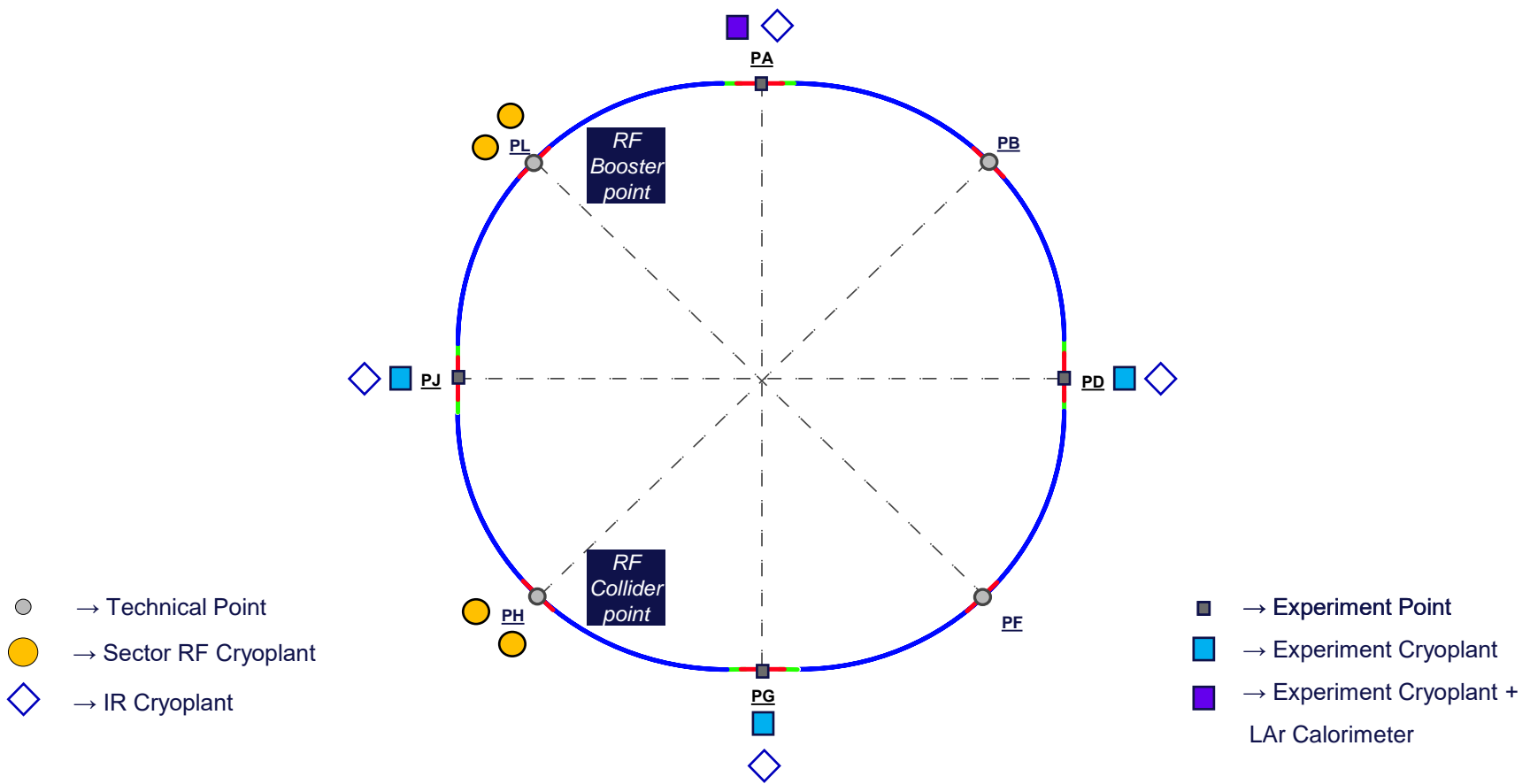

# Location of cryogenic cooling users

RF booster cavities



2 K

RF collider cavities

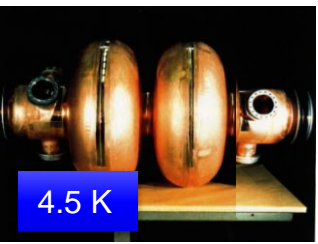

4.5 K



2 K

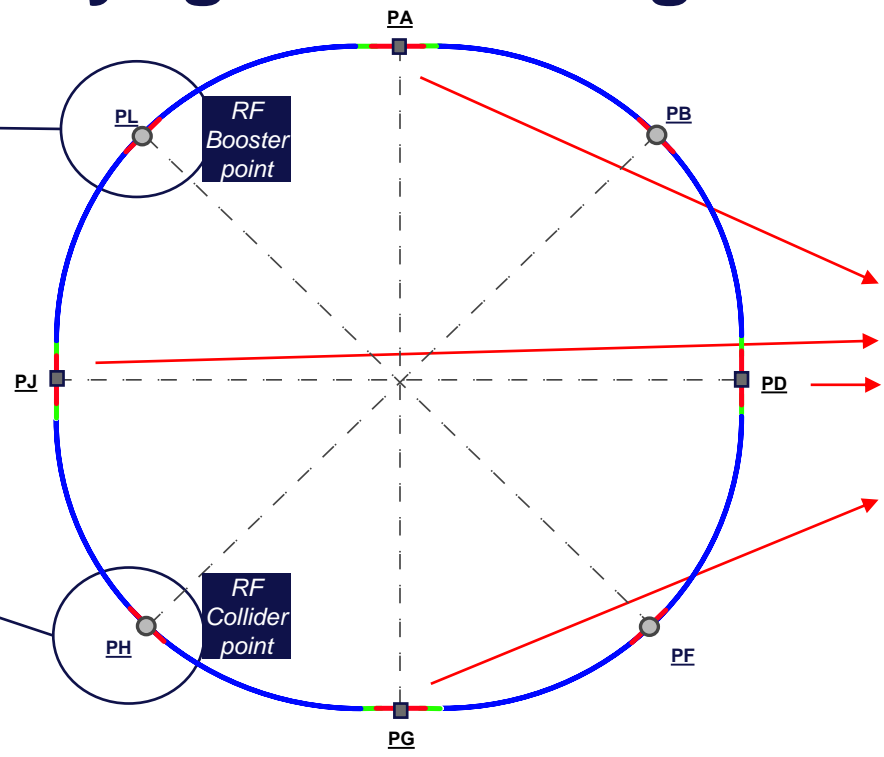

Detector solenoids and MDI magnets

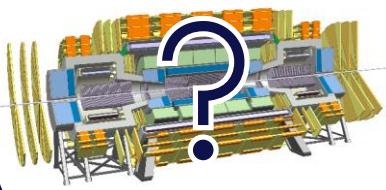

# FCC-ee Energy Stages

	Energy Stage	Description	Years of Operation*
FCC – ee (Mid 2040s)	Z	Z bosons are produced	10 Years
	W	W bosons are produced	
	H	Higgs Factory	
	ttbar	top quarks are produced	5 Years

*\*Referenced from ATDC meeting #21 (Evolution of FCC-ee 400 MHz cryomodule design)*

# FCC- ee Installation Staging Changes

2024

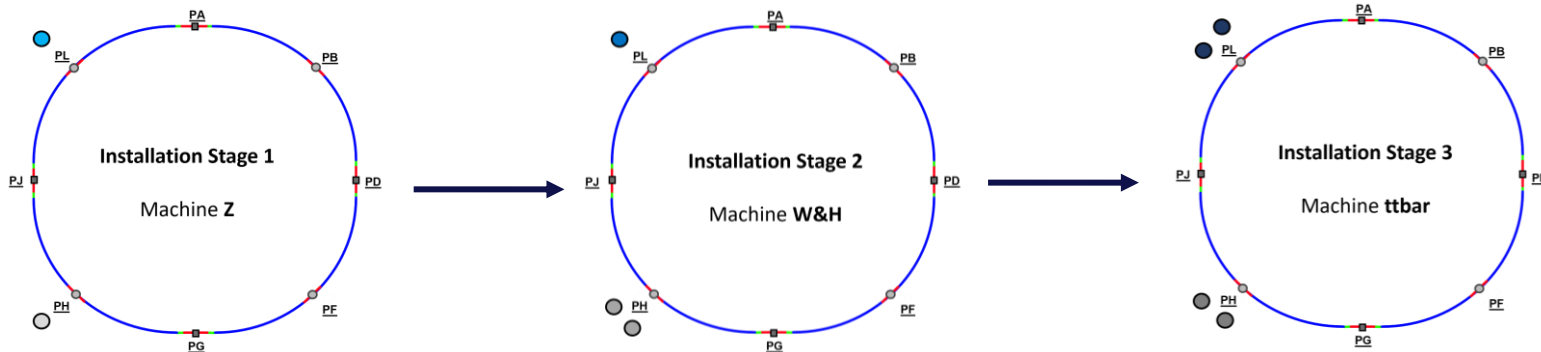

2025 RPO

(Reverse Phase Operation)

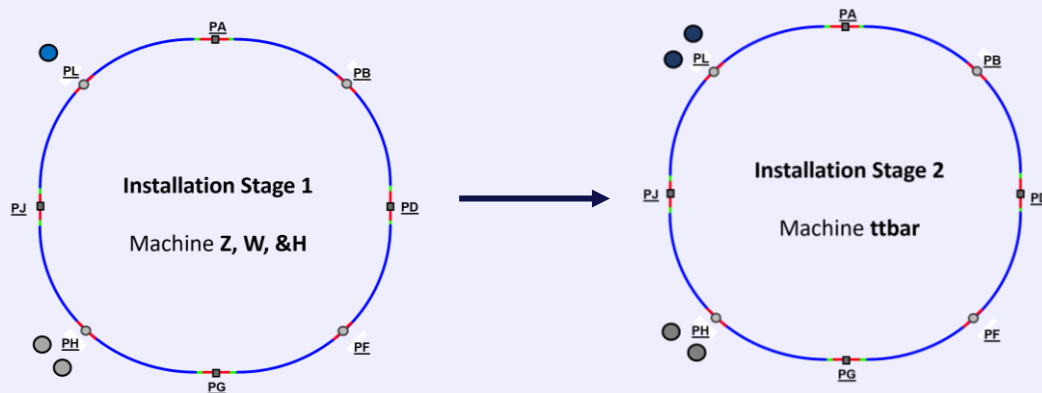

# FCC-ee Heat Loads

Heat load values coming from RF Team

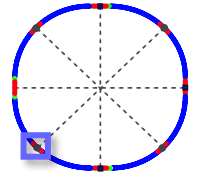

Point H

## PH (Collider): Jan 2025

FCC-PH (Collider)
Frequency [MHz]
Temperature [K]
No. of cryomodules
No. of cavities (x4)
<b>Static losses (to the thermal shield) / CM (no margins) [W]</b>
<b>Static losses (to the helium bath) / CM (no margin) [W]</b>
<b>Dynamic losses / CM (no margin) [W]</b>
<b>Dynamic losses / cav (no margin) [W]</b>
Total static to the thermal shield (with uncertainty factor) [kW]
Total static to the helium bath (with uncertainty factor) [kW]
Total dynamic (with overcapacity factor) [kW]

Z, W & H	ttbar	
400	400	800
4.5	4.5	2.0
66	66	102
264	264	408
218	218	120
131	131	37.3
512	516	108.5
128	129	27.1
21.6	21.6	18.4
13	13	5.7
50.7	51.1	16.6

The **Z & W** stage now have the **same** number of cryomodules and heat loads as the **H stage\***

**Decrease** in the number of 800 MHz cryomodules for ttbar\*

**Increase** in the static and dynamic heat loads for 800 MHz CMs\*

\*Changes since the Feasibility Study mid-term review

# FCC-ee Heat Loads

Heat load values coming from RF Team

FCC-PH (Collider)
Frequency [MHz]
Temperature [ K]
No. of cryomodules
No. of cavities (x4)
<b>Static losses (to the thermal shield) / CM (no margins) [W]</b>
<b>Static losses (to the helium bath) / CM (no margin) [W]</b>
<b>Dynamic losses / CM (no margin) [W]</b>
<b>Dynamic losses / cav (no margin) [W]</b>
Total static to the thermal shield (with uncertainty factor) [kW]
Total static to the helium bath (with uncertainty factor) [kW]
Total dynamic (with overcapacity factor) [kW]

The **Z & W** stage now have the **same** number of cryomodules and heat loads as the **H stage\***

**Decrease** in the number of 800 MHz cryomodules for ttbar\*

**Increase** in the static heat loads for 800 MHz CMs\*

Point L

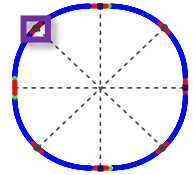

**PL (Booster): Jan 2025**

Z, W & H	ttbar
800	800
2.0	2.0
28	112
112	448
103	103
37	37
12	12
3	3
4.3	17.3
1.6	6.2
0.5	2.0

\*Changes since the Feasibility Study mid-term review

# Margins on FCC-ee Heat Loads

Type of Margin	Reason	Value
Uncertainty factor ( $F_{un}$ )	<ul style="list-style-type: none"> <li>For design uncertainty, engineering changes, and tolerances.</li> <li>Will evolve with the maturity of the design</li> </ul>	50% (applied to all static heat loads)
Overcapacity factor ( $F_{ov}$ ):	<ul style="list-style-type: none"> <li>To ensure nominal performance,</li> <li>Accounts for cryoplant ageing and operation flexibility</li> </ul>	50% (applied to all static + static uncertainty)
		50% applied to CM dynamic heat load

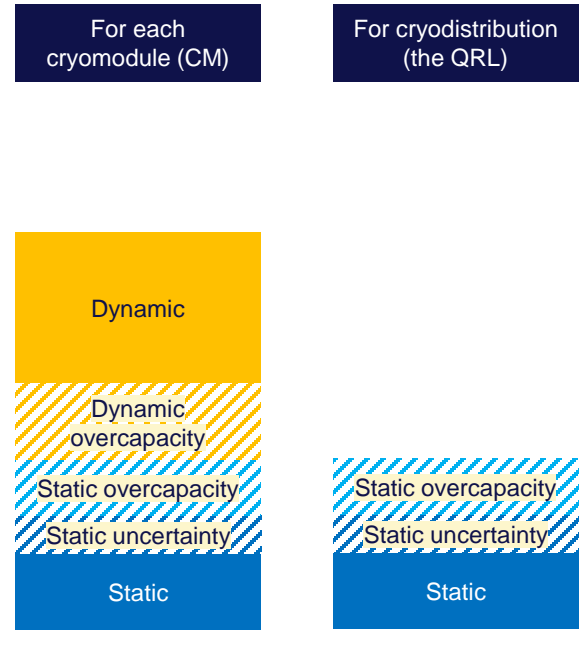

Heat load (W)

# FCC-ee Cooling Capacity

PH (Collider)

PL (Booster)

Operation	PH (Collider)		PL (Booster)	
	Z, W & H	ttbar	Z, W & H	ttbar
50-75 K (kW) per cryoplant	23.7	37.5	14.4	16.9
4.5 K (kW) per cryoplant	36.4	36.6	-	-
2 K (kW) per cryoplant	-	13.0	3.6	6.1
Nominal equivalent cooling capacity @ 4.5 K (kWeq) per cryoplant	<b>39.4</b>	<b>82</b>	<b>13.3</b>	<b>22.0</b>
Number of Cryoplants	<b>2</b>	<b>2</b>	<b>1</b>	<b>2</b>

Point L

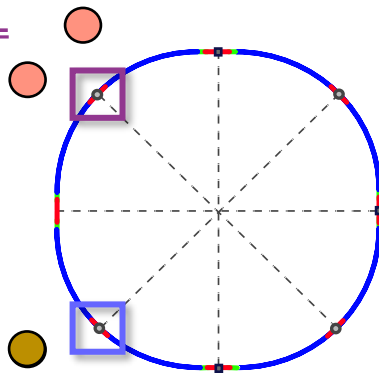

Point H

→ Sector RF Cryoplant

Basic timeline with the cryogenic cooling capacity required for each stage due to RPO for FCC-ee

Point L

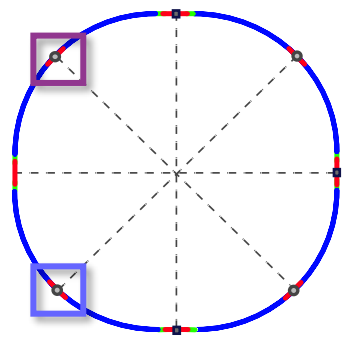

Point H

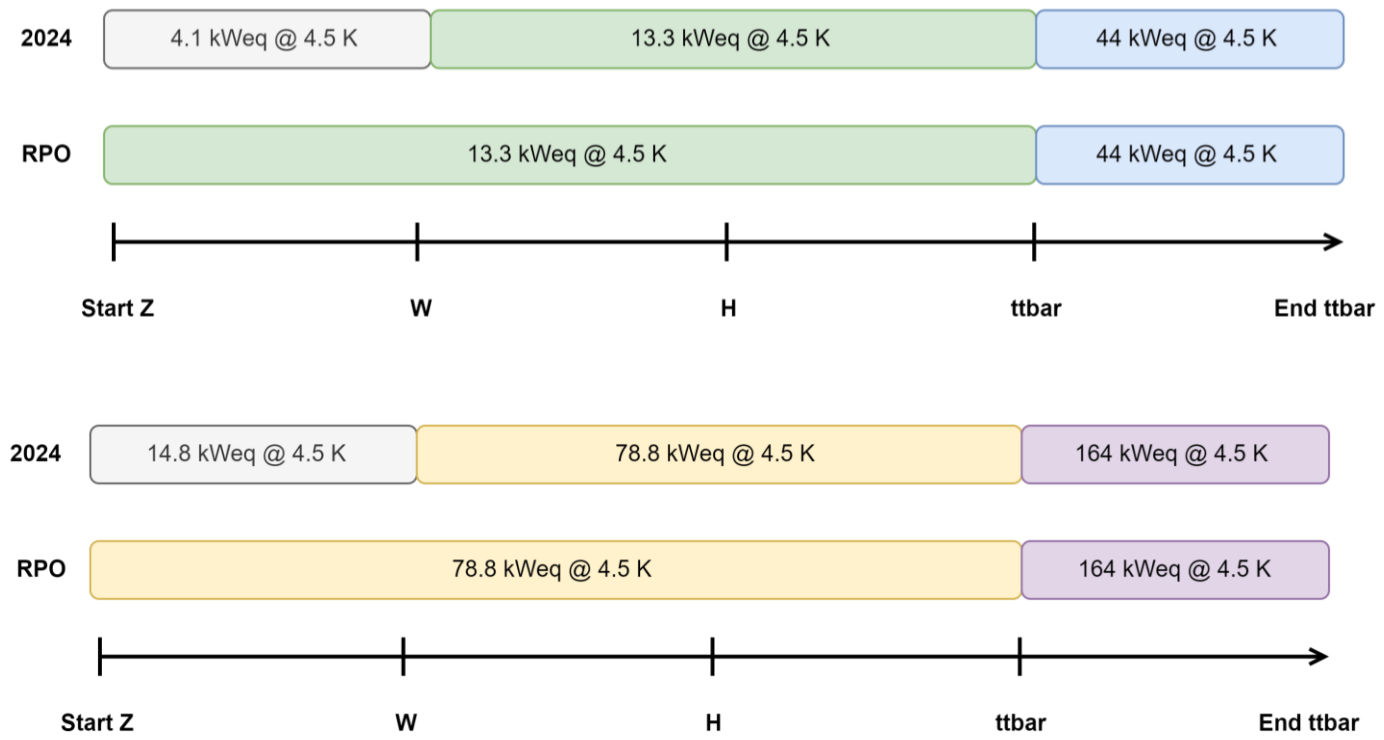

\*All values are the TOTAL Nominal equivalent cooling capacity at 4.5 K [kWeq] (not per cryoplant)

# Cryoplant Architecture

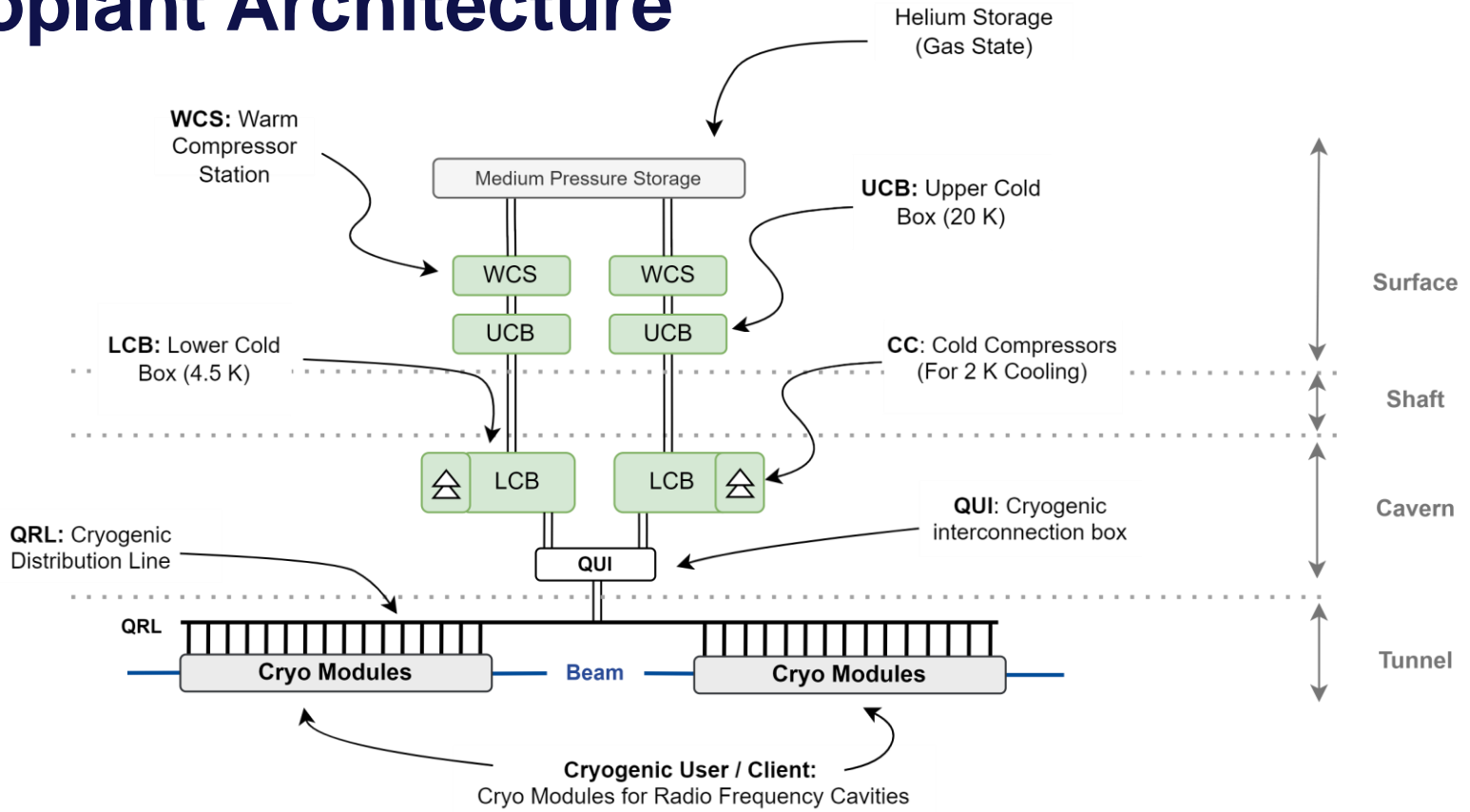

# Plant Architecture Staging

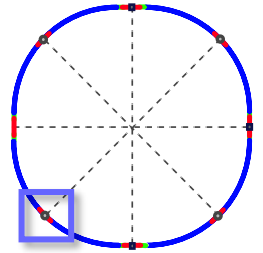

Point H

**WCS** = Warm Compressor Station

**UCB** = Upper Cold Box

**LCB** = Lower Cold Box

**QRL** = Cryogenic Distribution Line

**CM** = Cryomodule

**QUI** = Cryogenic interconnection box

Stage	Point	Energy	Time	Diagram
1	PH	Z	10 Yr	
		W		
		H		

2	PH	ttbar	5 Yr	
---	----	-------	------	--

# Plant Architecture Staging

Point L

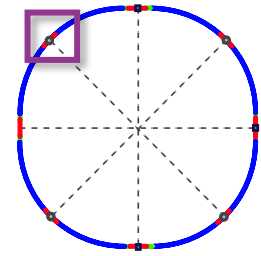

Stage	Point	Energy	Time	Diagram
-------	-------	--------	------	---------

1	PL	Z	10 Yr	<div style="border: 1px solid green; padding: 5px;"> <p>Cooling Capacity Required: 1 x 13.3 kWeq @ 4.5 K</p> </div>
		W		
		H		

2	PL	ttbar	5 Yr	<div style="border: 1px solid blue; padding: 5px;"> <p>Cooling Capacity Required: 2 x 22.0 kWeq @ 4.5 K</p> </div>
---	----	-------	------	------------------------------------------------------------------------------------------------------------------------

- WCS** = Warm Compressor Station
- UCB** = Upper Cold Box
- LCB** = Lower Cold Box
- QRL** = Cryogenic Distribution Line
- CM** = Cryomodule
- QUI** = Cryogenic interconnection box

# Cryogenics Electrical Power Consumption

YEARLY ELECTRICAL ENERGY CONSUM. FOR CRYO
Full Power [MW]
Eco Mode [MW]
Electrical Energy / year with ECO MODE [GWh]
Electrical Energy / year FULL MODE [GWh]

Mode	Type of Heat Loads	Period of Operation	Days of Operation	Temp of RF cavities
<b>Full Power</b>	Static + Dynamic	Commissioning + Machine Development (MD) + physics periods	235	4.5 K + 2 K
<b>Eco Mode*</b>	Static	YETS + Technical stop periods	130	4.5 K

\*Eco Mode is also known as standby mode in the LHC

Around **36%** of the year could be operated with a cryogenic economic mode

# Cryogenics Electrical Power Consumption

YEARLY ELECTRICAL ENERGY CONSUM. FOR CRYO	POINT H		POINT L	
	Z, W, & H	ttbar	Z, W, & H	ttbar
Full Power [MW]	17.34	36.08	2.92	9.69
Eco Mode [MW]	6.21	9.42	1.43	3.46
Electrical Energy / year with ECO MODE [GWh]	117.15	232.86	20.90	65.45
Electrical Energy / year FULL MODE [GWh]	151.86	316.05	25.56	84.91

YEARLY ELECTRICAL ENERGY CONSUM. FOR CRYO	TOTAL (PH + PL)		LHC 2024
	Z, W, & H	ttbar	
Full Power [MW]	20.25	45.77	-
Eco Mode [MW]	7.64	12.87	-
Electrical Energy / year with ECO MODE [GWh]	138.05	298.31	288
Electrical Energy / year FULL MODE [GWh]	177.41	400.96	295

# Cryogenic Distribution Line (Point H)

- No changes in QRL sizes since the 2024 midterm report
- Lengths have slightly increased due to change in cryomodule lengths

Line Name PH	Size PH
A (1.3 bar, 2.2 K)	80 mm
B (30 mbar, 2.0 K)	345 mm
C (3 bar, 4,6 K)	120 mm
D (1.3 bar, 4,5 K)	200 mm
E (20 bar, 50 K)	80 mm
F (18 bar, 75 K)	80 mm

Cross sectional view of QRL:

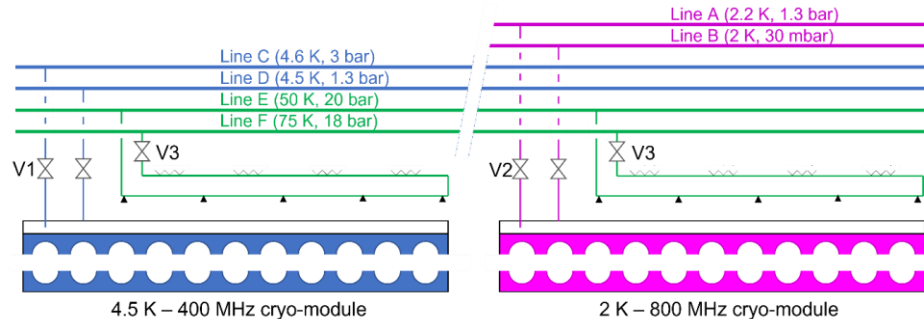
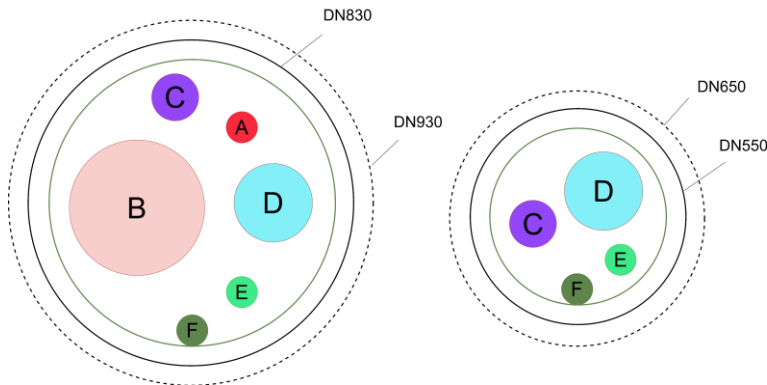

# Cryogenic Distribution Line (Point L)

- No changes in QRL sizes since the 2024 midterm report
- Lengths have slightly increased due to change in cryomodule lengths

Cross sectional view of QRL:

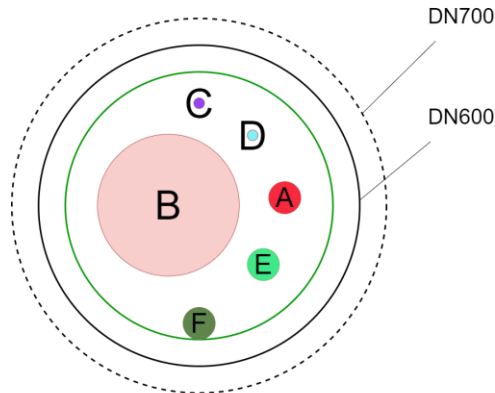

Line Name PL	Size PL
A (1.3 bar, 2.2 K)	60 mm
B (30 mbar, 2.0 K)	265 mm
C (3 bar, 4,6 K)	20 mm
D (1.3 bar, 4,5 K)	20 mm
E (20 bar, 50 K)	60 mm
F (18 bar, 75 K)	60 mm

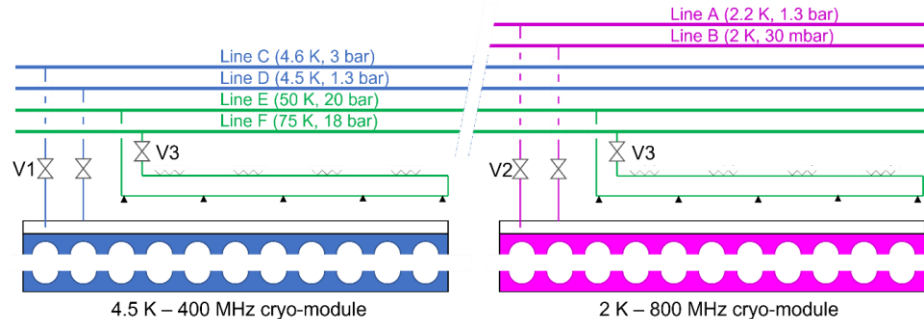

# Total Helium Inventory Changes (PH + PL)

Total He Mass: PH + PL	POINT H		POINT L	
	Z, W, & H	ttbar	Z, W, & H	ttbar
CM He Mass Total [t]	7.66	13.27	1.5	6.2
Distribution He Mass [t]	4.17	5.19	0.8	0.8
Cryoplant He Mass [t]	2.74	5.69	0.46	1.53
<b>Total He Mass [t]</b>	<b>14.56</b>	<b>24.16</b>	<b>2.8</b>	<b>8.54</b>

Total He Mass: PH + PL	Z, W, & H	ttbar
CM He Mass Total [t]	9.20	19.43
Distribution He Mass [t]	5.01	6.04
Cryoplant He Mass [t]	3.20	7.22
<b>Total He Mass [t]</b>	<b>17.40</b>	<b>32.69</b>
No. Medium Pressure Storage Tanks	26	47

**Small Increase** in total helium mass for the Z, W, & H stage

**Decrease** in helium mass for the ttbar stage since the Feasibility Study mid-term review. Caused by a **decrease in the number of CMs**

## Conclusion

New RPO baseline has installation impacts on the cryogenic system

Changing Heat Loads and cryogenic demands need to be accounted for

Further details on the cryogenic system can be found in the published Feasibility Study report

## Next Steps

Pre-TDR study is launched

Further investigation into the integration and feasibility of the C-HEX design

Launch engineering study with key industry partners and suppliers to validate cryogenic cooling systems

# Thank you

# Extra Slides

# FCC-ee Heat Loads

\* Heat load values coming from RF Team

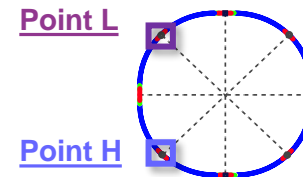

PH (Collider): Jan 2025

	Z, W & H	ttbar	
Frequency [MHz]	400	400	800
Temperature [K]	4.5	4.5	2.0
No. of cryomodules	66	66	102
No. of cavities (x4)	264	264	408
<b>Static losses (to the thermal shield) / CM (no margins) [W]</b>	218	218	120
<b>Static losses (to the helium bath) / CM (no margin) [W]</b>	131	131	37.3
<b>Dynamic losses / CM (no margin) [W]</b>	512	516	108.5
<b>Dynamic losses / cav (no margin) [W]</b>	128	129	27.1
Total static to the thermal shield (with uncertainty factor) [kW]	21.6	21.6	18.4
Total static to the helium bath (with uncertainty factor) [kW]	13	13	5.7
Total dynamic (with overcapacity factor) [kW]	50.7	51.1	16.6

PL (Booster): Jan 2025

	Z, W & H	ttbar
Frequency [MHz]	800	800
Temperature [K]	2.0	2.0
No. of cryomodules	28	112
No. of cavities (x4)	112	448
<b>Static losses (to the thermal shield) / CM (no margins) [W]</b>	103	103
<b>Static losses (to the helium bath) / CM (no margin) [W]</b>	37	37
<b>Dynamic losses / CM (no margin) [W]</b>	12	12
<b>Dynamic losses / cav (no margin) [W]</b>	3	3
Total static to the thermal shield (with uncertainty factor) [kW]	4.3	17.3
Total static to the helium bath (with uncertainty factor) [kW]	1.6	6.2
Total dynamic (with overcapacity factor) [kW]	0.5	2.0

= **INCREASED**  
From 2024 Values

= **DECREASED**  
From 2024 Values

# FCC-ee Electrical Power Consumption

## 2024

YEARLY ELECTRICAL ENERGY CONSUM. FOR CRYO (PH + PL)	Z	W	H	ttbar	LHC 2024
Full Power [MW]	3.5	17.4	18.8	46.4	-
Eco Mode [MW]	3.4	6.7	7.1	13.8	-
Electrical Energy / year with ECO MODE [GWh]	30.5	119.1	127.8	304.9	288
Electrical Energy / year FULL MODE [GWh]	31.0	152.6	164.3	406.5	295

## Jan 2025 (RPO)

YEARLY ELECTRICAL ENERGY CONSUM. FOR CRYO (PH + PL)	Z, W, & H	ttbar	LHC 2024
Full Power [MW]	20.25	45.77	-
Eco Mode [MW]	7.64	12.87	-
Electrical Energy / year with ECO MODE [GWh]	138.05	298.31	288
Electrical Energy / year FULL MODE [GWh]	177.41	400.96	295

 = **INCREASED**  
From 2024 Values

 = **DECREASED**  
From 2024 Values

# FCC-ee Electrical Power Consumption

*Reasons For Changed Electrical Consumption:*

## Point H (Collider):

- Slight increase in dynamic and static heat loads for 800 MHz (2 K) cryomodules
- Decrease of the number of 800 MHz cryomodules for tt bar

## Point L (Booster):

- Increase in static heat loads for 800 MHz (2 K) cryomodules
- Decrease of 800 MHz cryomodules for tt bar

 = **INCREASED**

From 2024 FCC week

 = **DECREASED**

From 2024 FCC week

YEARLY ELECTRICAL ENERGY CONSUM. FOR CRYO	TOTAL (PH + PL)		LHC 2024
	Z, W, & H	ttbar	
Full Power [MW]	20.25	45.77	-
Eco Mode [MW]	7.64	12.87	-
Electrical Energy / year with ECO MODE [GWh]	138.05	298.31	288
Electrical Energy / year FULL MODE [GWh]	177.41	400.96	295

# Total Helium Inventory Distribution

2025 (RPO)

Total He Mass: PH + PL	Z, W, & H	ttbar
<b>CM He Mass Total [t]</b>	9.20	19.43
<b>Distribution He Mass [t]</b>	5.01	6.04
<b>Cryoplant He Mass [t]</b>	3.20	7.22
<b>Total He Mass [t]</b>	17.40	32.69
<b>No. Medium Pressure Storage Tanks</b>	26	47

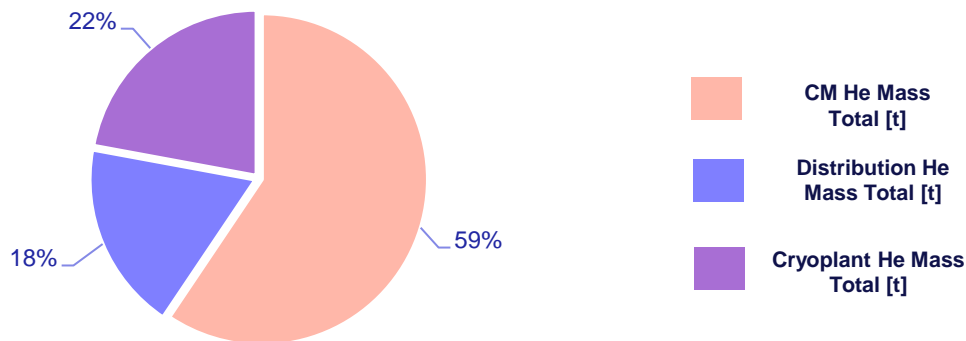

# Total Helium Inventory Changes (PH + PL)

Oct 2024

Total He Mass: PH + PL	Z	W	H	ttbar
CM He Mass Total [t]	3.58	8.43	9.14	22.62
Distribution He Mass [t]	4.96	4.96	4.96	5.92
Cryoplant He Mass [t]	0.67	2.96	3.17	7.67
Total He Mass [t]	9.21	16.34	17.26	36.21
No. Medium Pressure Storage Tanks	14	25	26	53

 = INCREASED

 = DECREASED

2025 (RPO)

Total He Mass: PH + PL	Z, W, & H	ttbar
CM He Mass Total [t]	9.20	19.43
Distribution He Mass [t]	5.01	6.04
Cryoplant He Mass [t]	3.20	7.22
Total He Mass [t]	17.40	32.69
No. Medium Pressure Storage Tanks	26	47

ttbar distribution inventory increase is due to the increased QRL length

# FCC-ee cooling scheme and cryodistribution

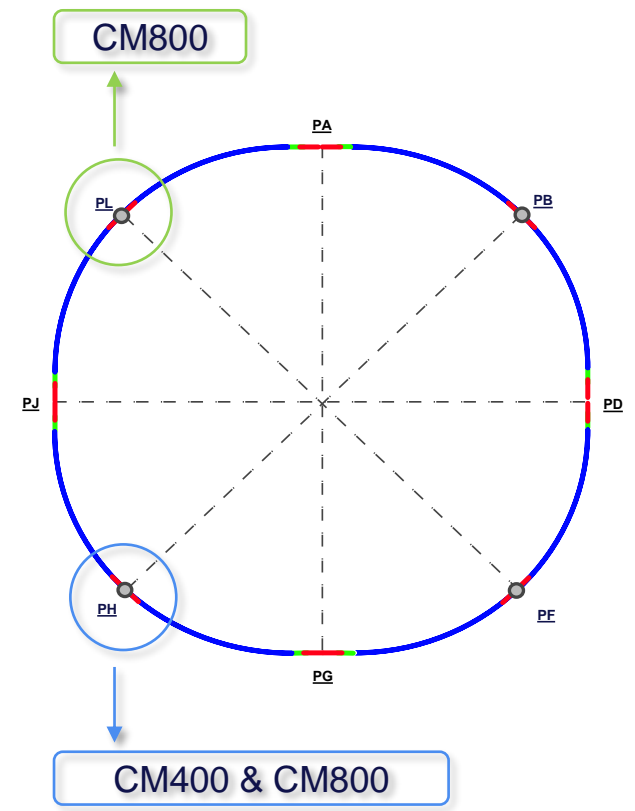
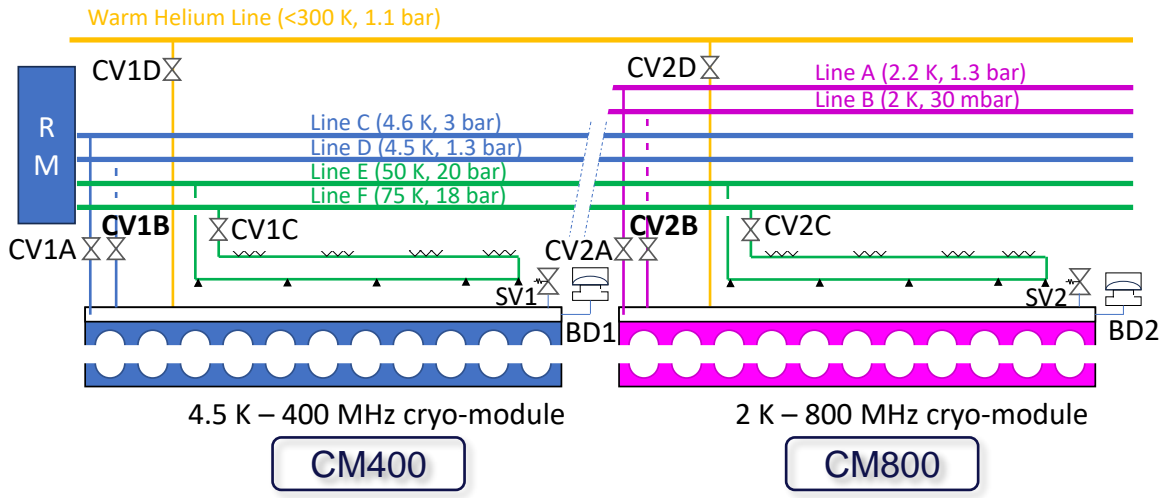
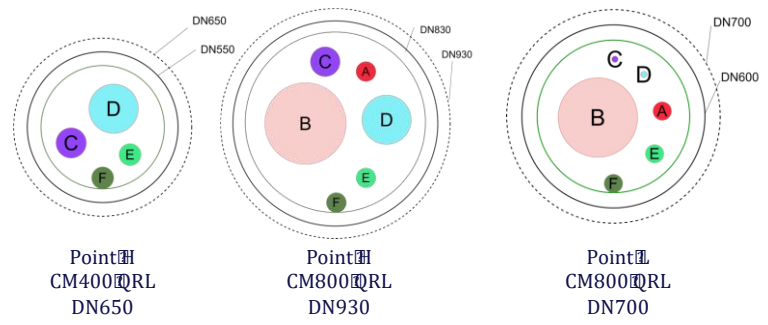

# FCC operation Modes – typical year

## → Phases in a typical year – 365 days

→ Shutdown phase – 120 days (33%) **Cryo in ECO mode**

→ The machine is stopped and open for upgrade works, maintenance and repairs.

→ Operation phase – 245 days (67%)

→ Hardware and beam commissioning – 30 days

→ All systems are restarted and tested before operation.

→ **Physics operation – 185 days**

→ Beam is stable and collides for experiments.

→ Technical stops – 10 days **Cryo in ECO mode**

→ Planned stops during operation to perform maintenance and repairs.

→ Machine development – 20 days

→ Planned activities with beam operation to improve beam performance.

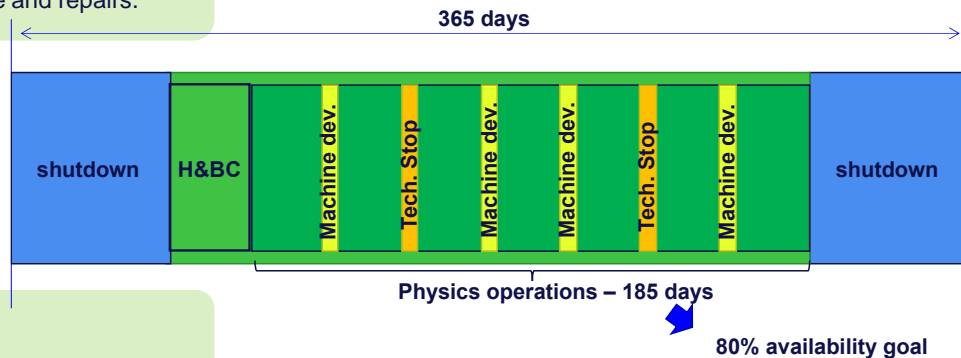

→ **Availability target – 80 % of physics operation**

→ **The modes will impact cryoplants' design and energy consumption**

→ (about 25% estimated savings with ECO mode)

# FCC-ee – EL power Assumptions

→ **Three scenarios are considered:**

- **Conservative:** 230 Wel/W or 28.8 % of Carnot efficiency (LHC-like – CDR values)  
the baseline!
- **Intermediate:** 220 Wel/W or 30% of Carnot efficiency (With an optimized process)  
Currently used in calculations
- **Optimistic:** 170 Wel/W or 39 % of Carnot efficiency (With centrifugal compressors)  
Strong R&D effort needed
- **Economic Mode:** 250 Wel/W or 26% of Carnot efficiency  
Worse COP due to cryoplant not running at optimal capacity

# FCC-ee Experimental Point cryoplants layout

Experiment points cryogenics

**Detector solenoid :**

Number of experiments and their heat loads have not been defined yet.

- Option 1 (baseline):
  - 4 “CMS-like” cryoplants, one of which has a LAr calorimeter.
- Option 2:
  - 2 “CMS-like” cryoplants, one of which has a LAr calorimeter.

**Insertion Region magnets:**

- Unknown heat loads.

Not covered!

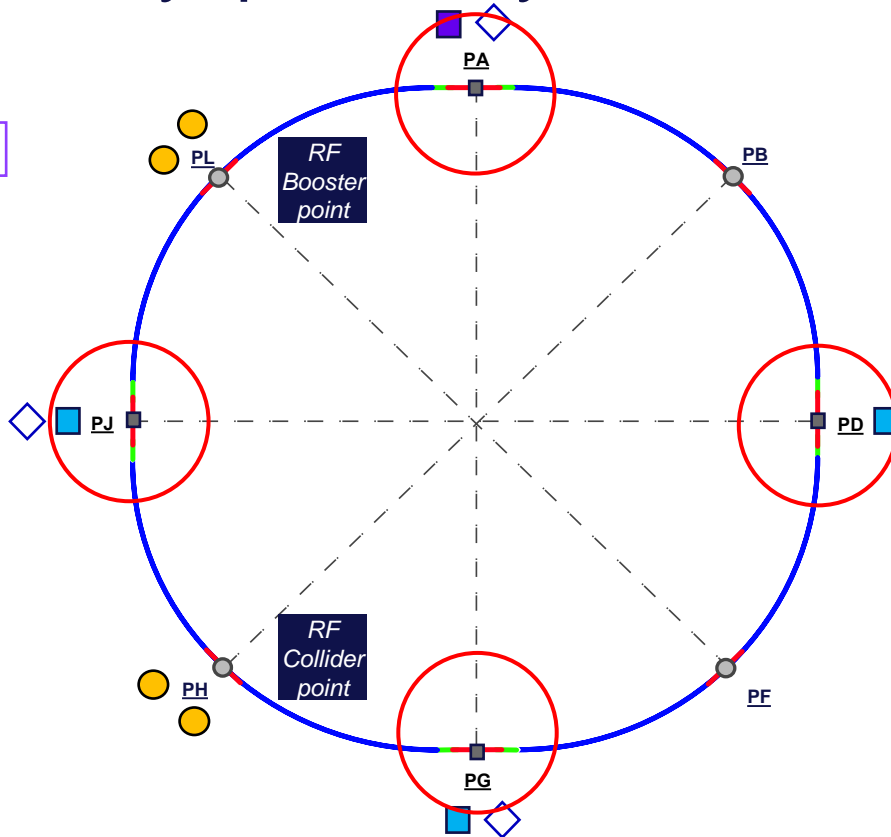

ttbar stage is the driver for surface needs, shaft and tunnel integration.