



# Pion rejection studies for ALLEGRO's high-granularity noble liquid ECAL



Martina Koppitz<sup>1,2</sup> on behalf of the ALLEGRO ECAL group  
1 TU Dresden, Germany  
2 CERN, Switzerland

## Noble Liquid Calorimetry

Well-proven, successful technology:

- Good energy resolution ✓
- Linearity ✓
- Stability ✓
- Uniformity of response ✓
- Easy to calibrate ✓
- Cost-efficient ✓

Absorber/passive material:

- shower initiation
- energy loss

Active material:

Electromagnetic shower particles ionize noble liquid

Readout:

Electrons and ions drift due to applied high voltage and induce signal

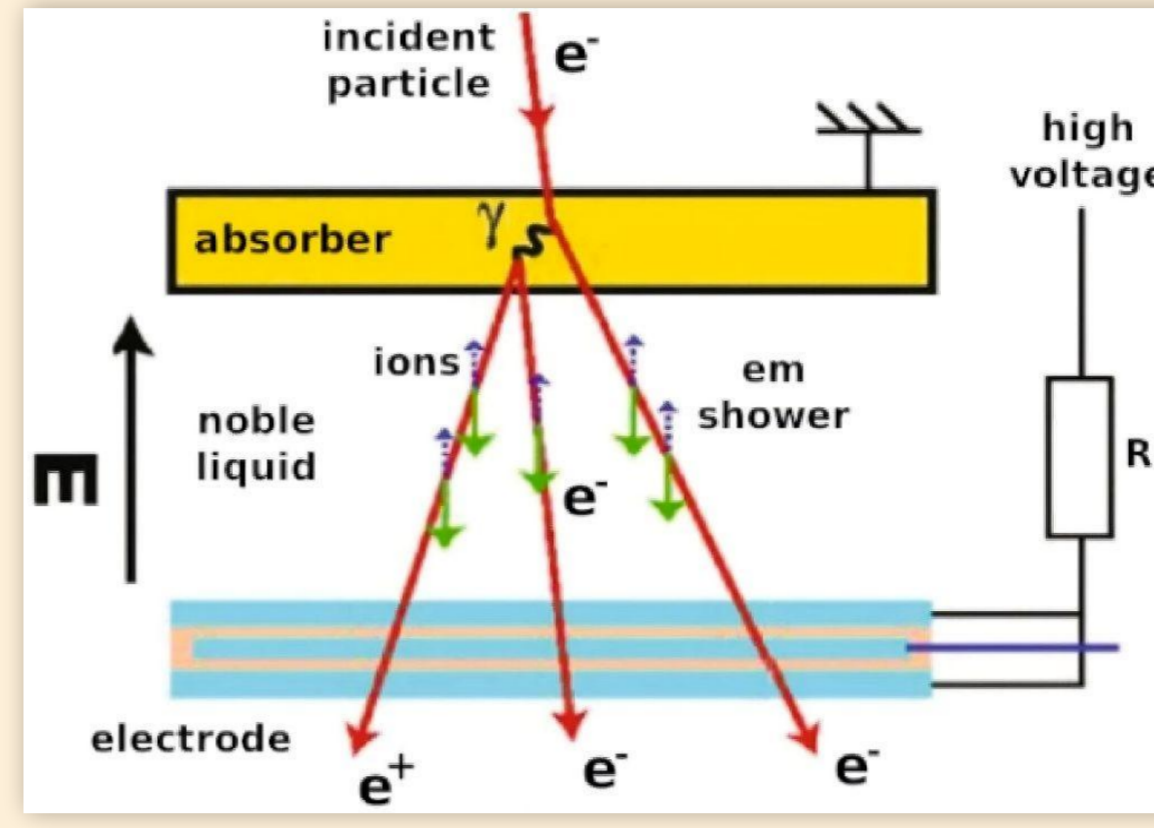

FCC-ee's ambitious and diverse physics programme sets stringent requirements for detectors like:

- Good jet energy resolution (4% at 50 GeV)
- High granularity
- Particle ID capabilities
- Small systematic uncertainties

Development of noble liquid calorimeter targeting these challenges!

## ALLEGRO

### Detector Concept

ALLEGRO (A Lepton Lepton Collider Experiment with Granular Read-Out)

General-purpose detector concept featuring high granular noble liquid sampling electromagnetic calorimeter (ECAL):

1536 straight inclined (50°) absorber plates

Baseline design: liquid argon as active material and lead absorbers

11 longitudinal layers, 22 X<sub>0</sub>

Lightweight carbon fibre cryostat

Typical cell size:  $\theta \times \phi \times r \sim 2 \times 1.8 \times 3 \text{ cm}^3$

Strip layer:  $\sim 0.5 \times 1.8 \times 3 \text{ cm}^3$

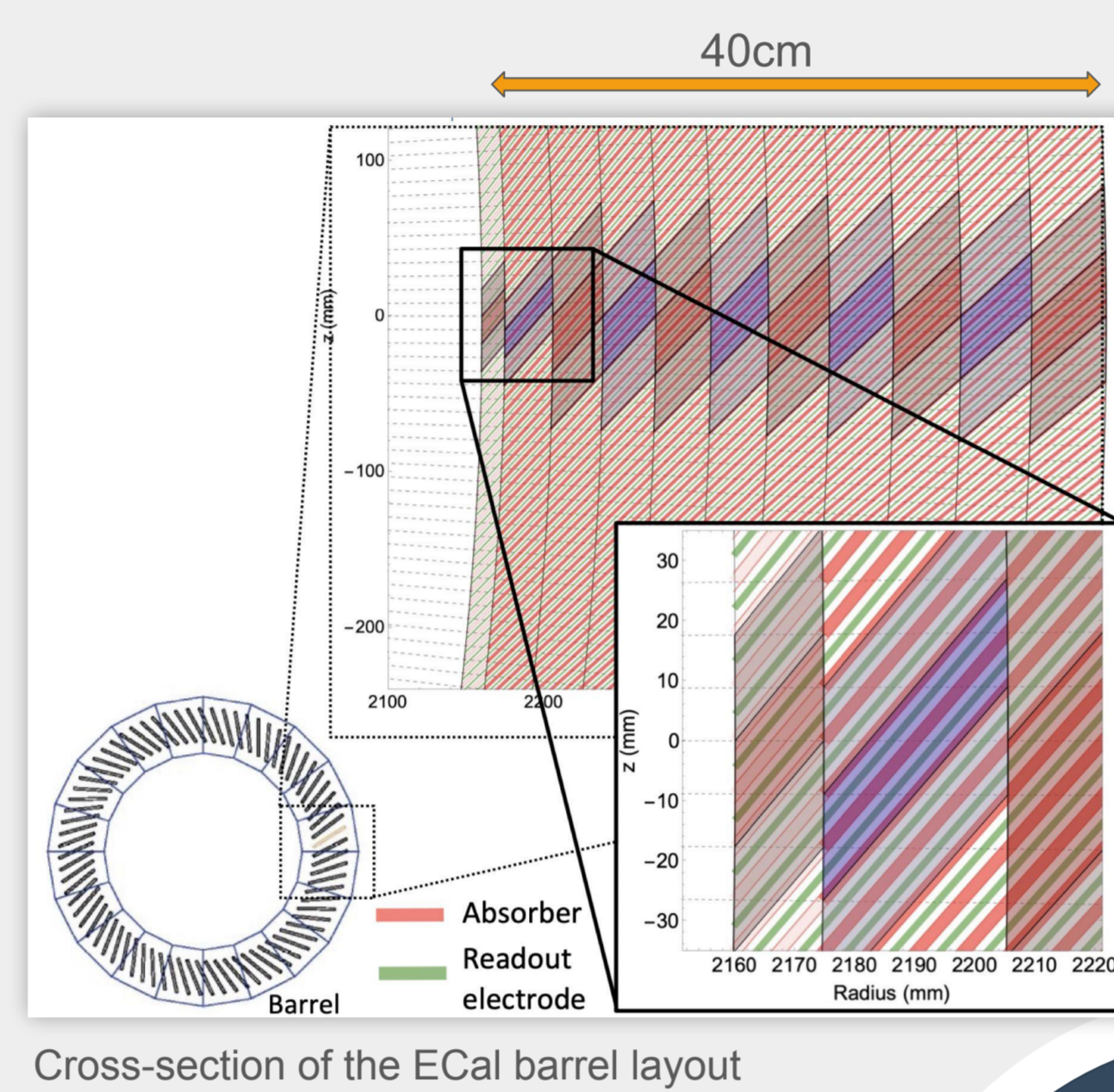

### Readout

High granularity achieved by segmentation of readout electrode

Crucial for advanced reconstruction methods like particle flow!

Electrodes for readout realized on Printed Circuit Boards (PCB)

Multilayer:

- High voltage layers
- Pads collect ionization signal
- Shields to minimize cross-talk

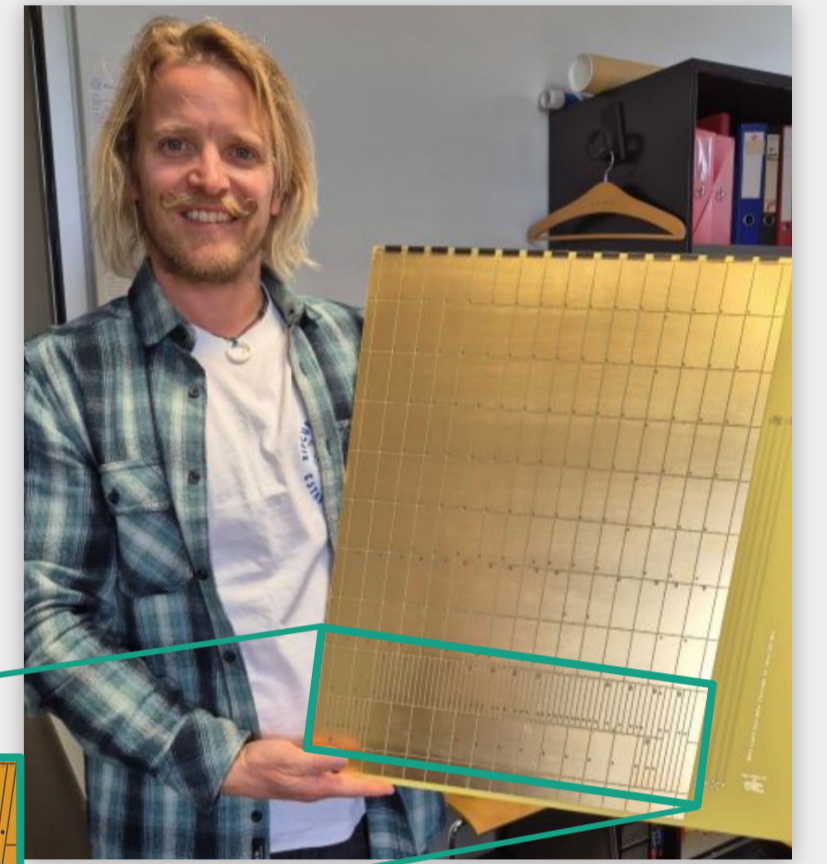
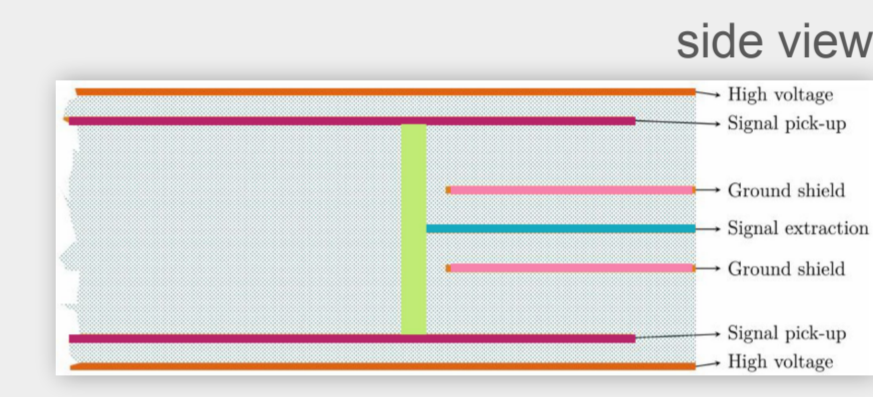

Studies showed that cross-talk signal below 1% easily achievable, down to 0.1% feasible with long shaping time

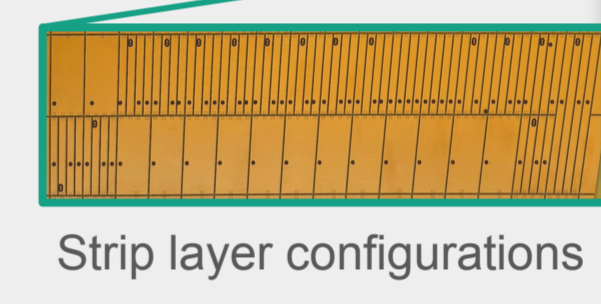

## $\pi^0/\gamma$ Separation

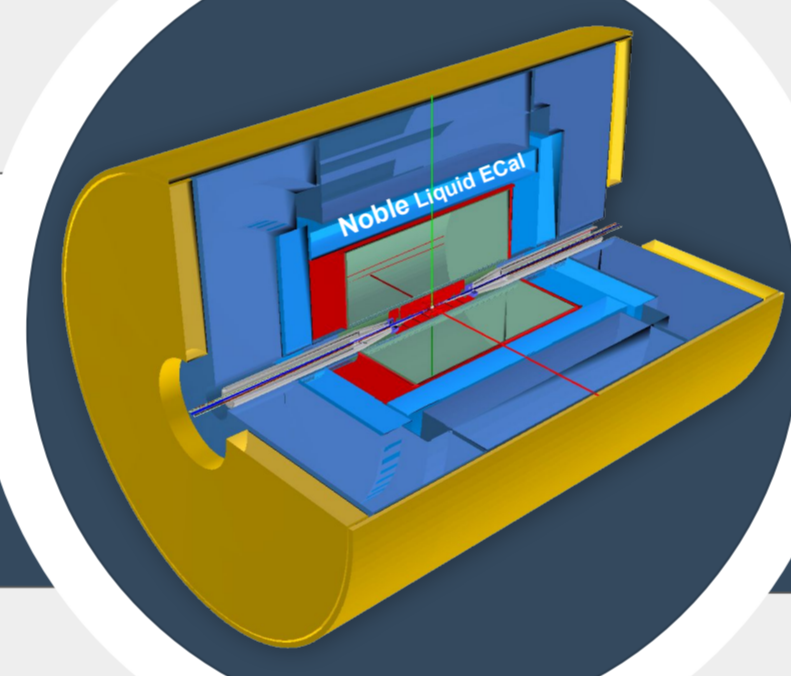

Full simulation integrated within FCC software & key4hep, geometry based on DD4hep & Geant4

Pion rejection

$\pi^0 - \gamma\gamma$  little angular separation towards high energies

How can we separate them?

"Strip layer" with 4x higher granularity

Shower shape variables such as lateral width and energy distribution profiles, are being studied to characterize these subtle differences and improve discrimination.

Evaluating the impact of various strip layer positions on  $\pi^0$  rejection performance

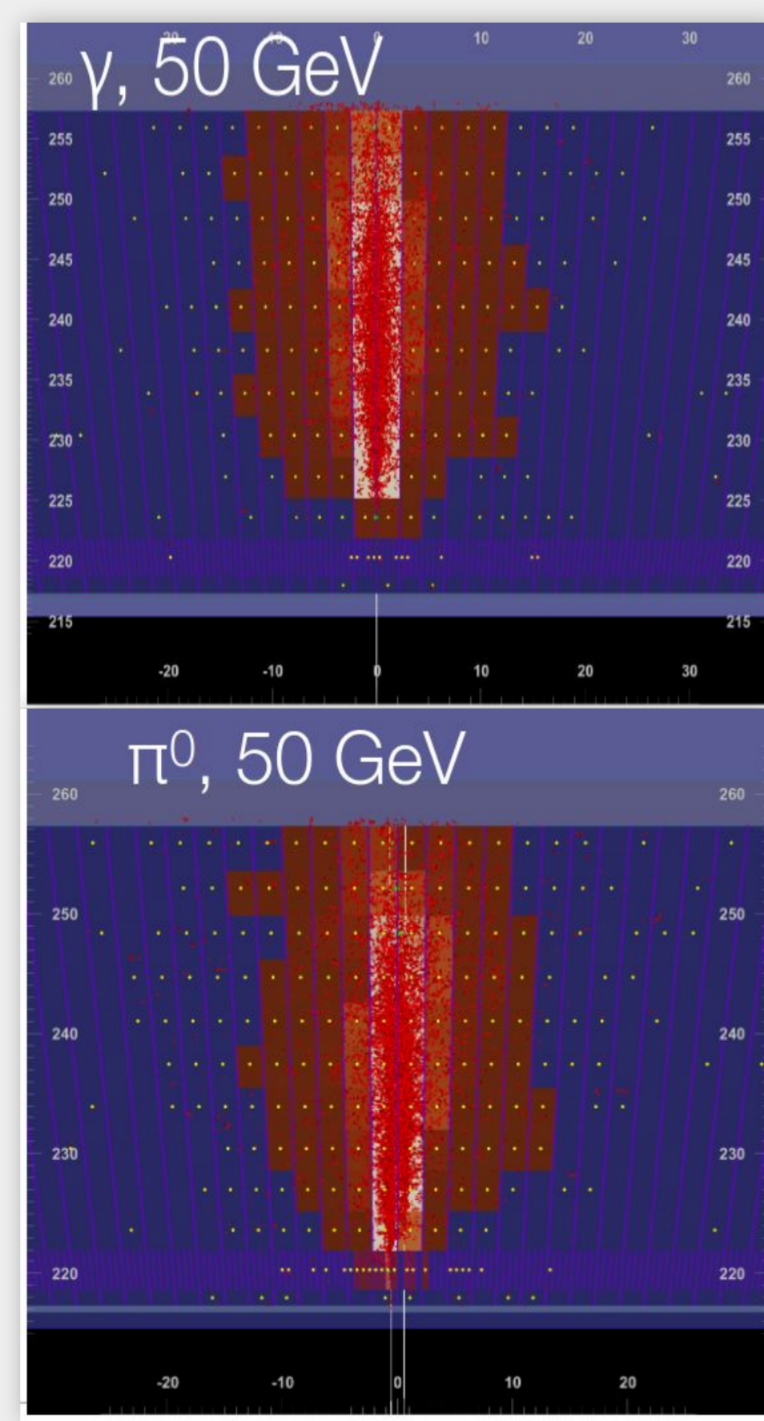

$$E_{ratio} = \frac{E_1 - E_2}{E_1 + E_2}$$

Asymmetry between 1st (E1) and 2nd (E2) maxima

$$\Delta E = E_{2nd\_max} - E_{min}$$

Difference between 2nd max and min strip between 1st and 2nd maximum

$$F_{side} = \frac{E_7 - E_3}{E_3}$$

Fraction of energy outside the core

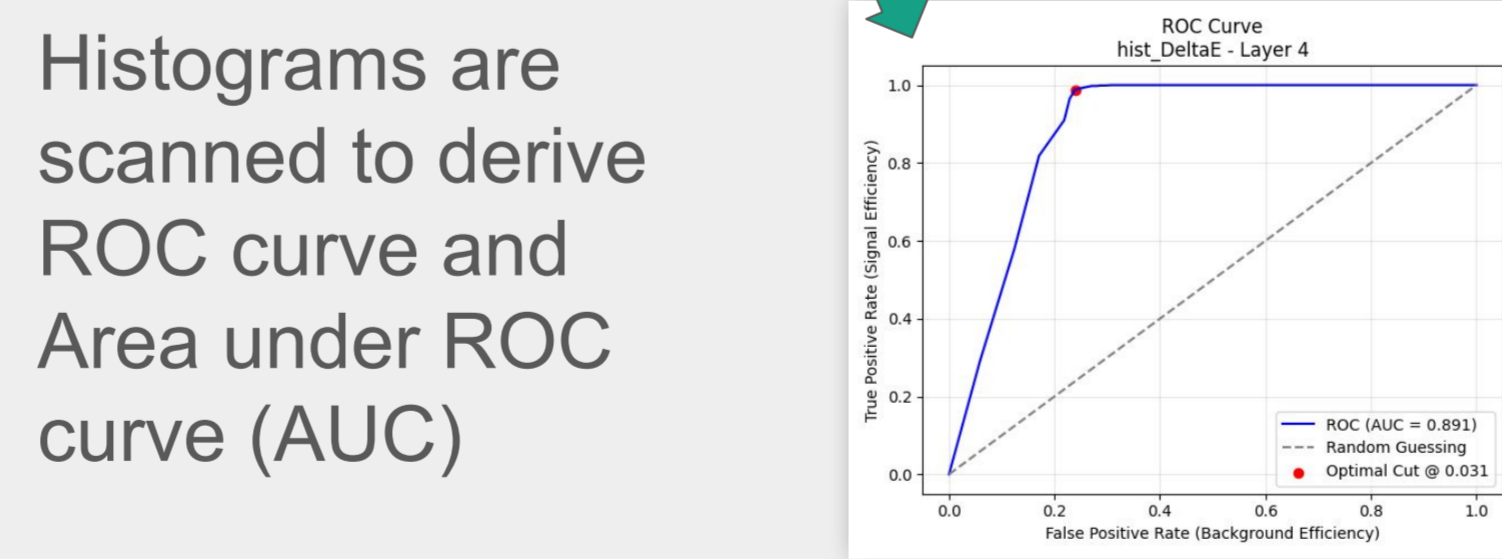
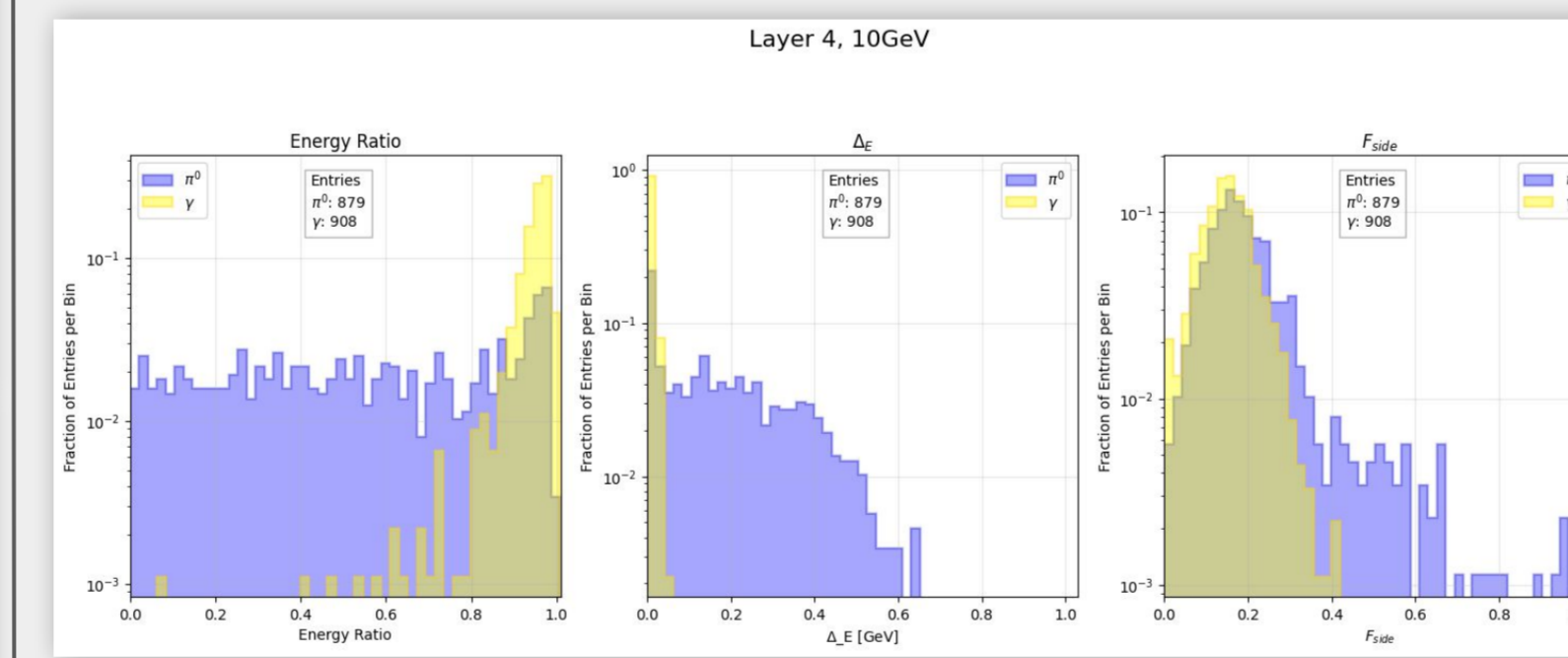

The AUC describes the probability that the classifier correctly identifies randomly chosen signal ( $\gamma$ ) over background ( $\pi^0$ ).

Preliminary results indicate that different shower shape variables are optimal at different energy ranges.

Showers develop relatively deep in the detector, pushing the strip layer further back than originally planned could enhance the pion rejection performance.

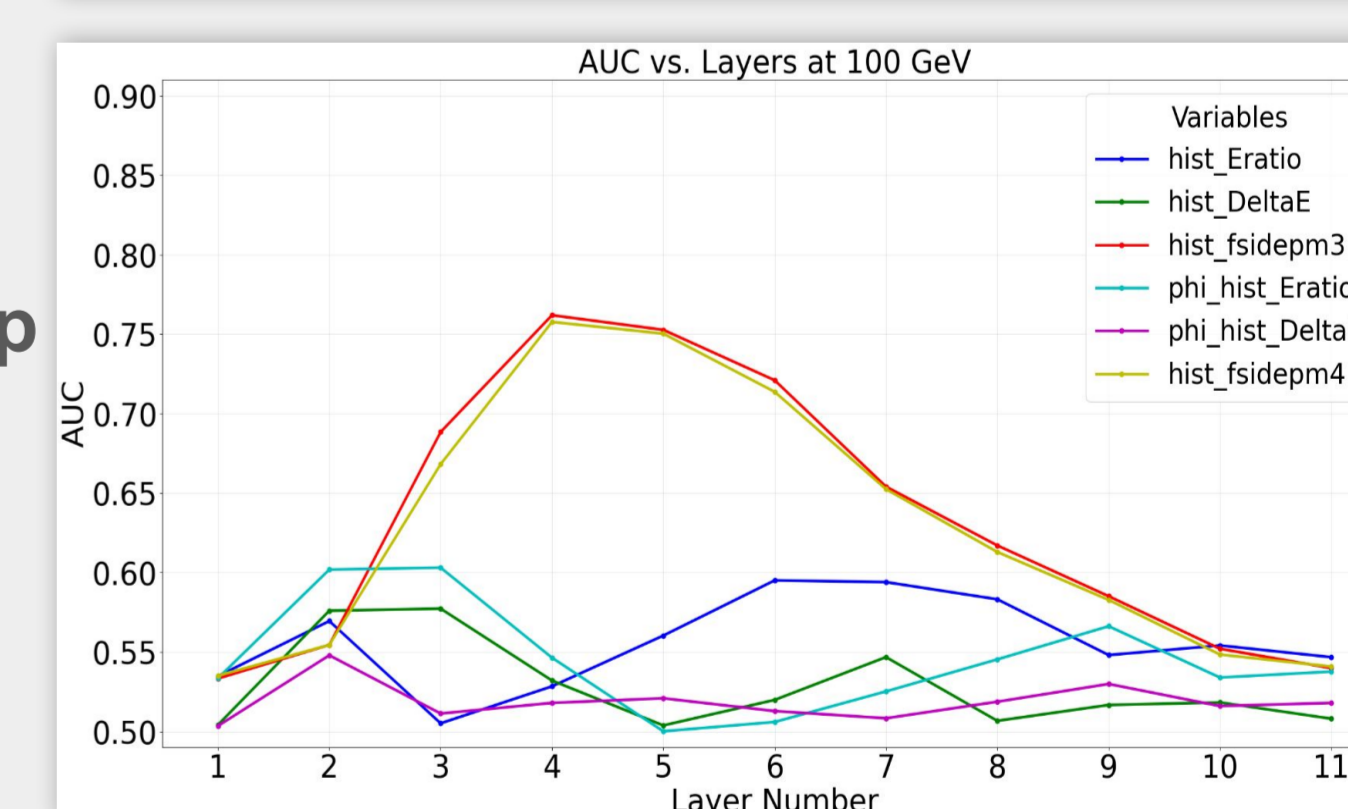
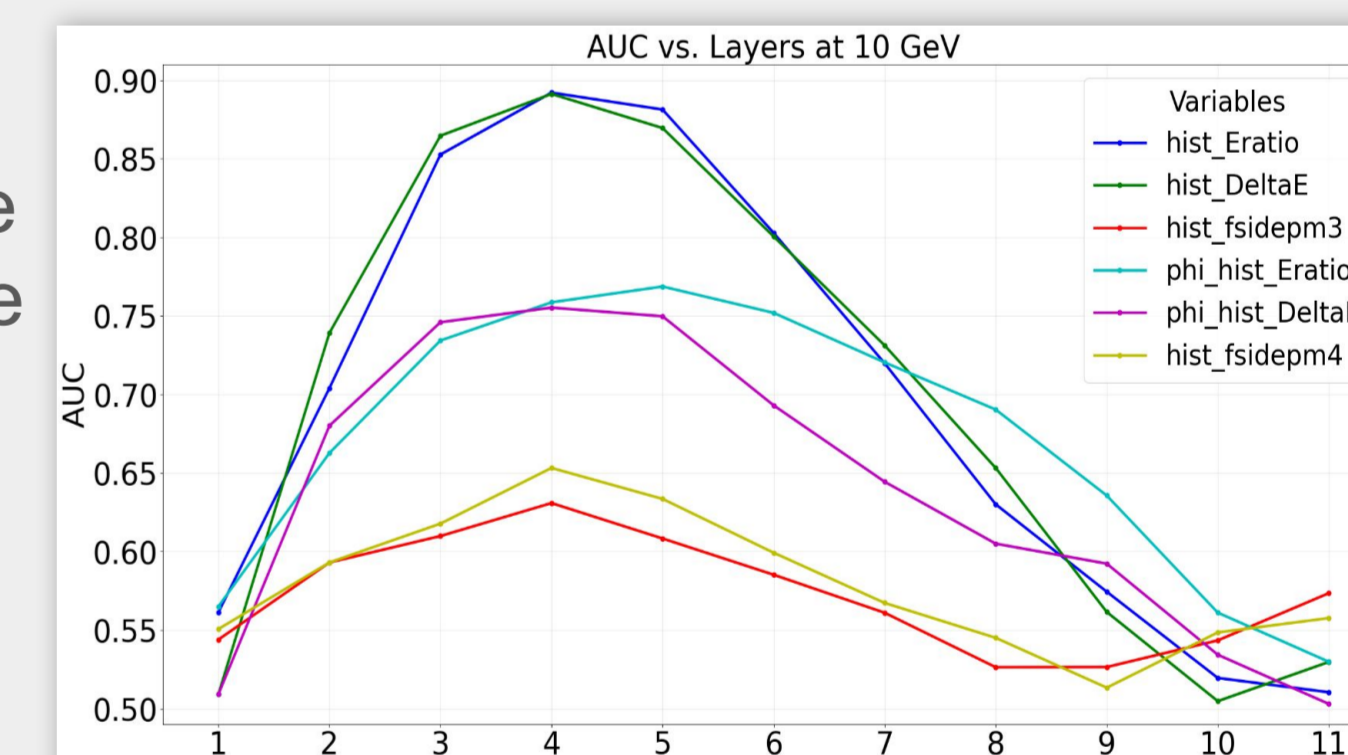

Area under ROC curve in all layers for different shower shape variables for 10 GeV and 100 GeV

## Outlook

New PCB prototype featuring different segmentation setups, signal tracing and shielding configurations undergoing first measurements at CERN, BNL and IJCLab!

Simulation studies ongoing to evaluate material choices as well as optimized granularity for  $\gamma/\pi^0$  separation

Particle Flow studies started to further study granularity requirements

Development of full readout chain design based on cold electronics at BNL

Testbeam prototype of full module in the upcoming years

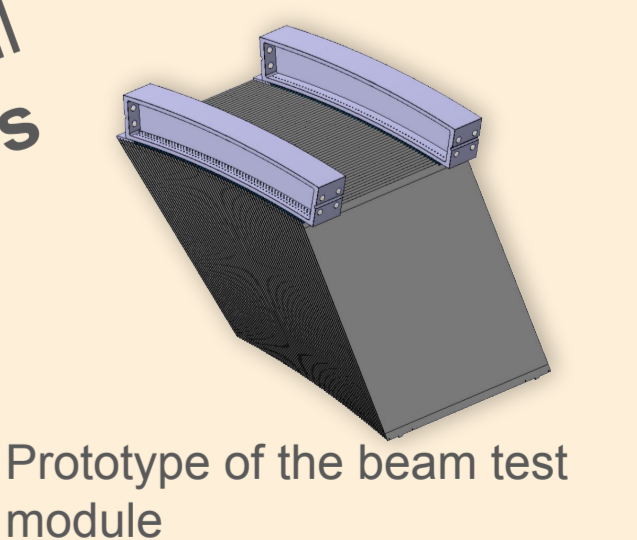

The future is exciting, come and join us!



FCC Week Vienna  
19-23 May 2025

Contact: [martina.koppitz@cern.ch](mailto:martina.koppitz@cern.ch)

R&D on Noble Liquid Calorimetry is part of the "Detector Research and Development Collaboration for Calorimeters" (DRD6), forming work package 2 (WP2)