

**Thursday**

**1:30 PM → 3:00 PM** **Technical Infrastructure: Cooling & Ventilation, Geodesy** Trabantenstube

Convener: Ingo Ruehl (CERN)

**1:30 PM** **Ventilation update for FCC** 🕒 23m

The ventilation system for the FCC is designed to supply, condition, and extract air throughout the entire accelerator complex. This includes the Technical Areas, Experimental Areas, RF Areas, the Tunnel, and surface buildings. The supplied air must comply with safety, humidity, and temperature standards. This presentation will provide an overview of this system, with a focus on the updated thermal loads to air, the integration of ventilation within the various facilities and the alternative longitudinal ventilation concept proposed of the Tunnel.

**Speaker:** Inigo Martin Melero (CERN)

**1:53 PM** **Cooling update for FCC** 🕒 22m

The water-cooling systems of the FCC are designed to remove the heat generated by critical components such as magnets, cryogenic systems, absorbers, and electronics. This presentation will provide an overview of the current design status of these systems, highlighting updates on the thermal loads managed by the cooling systems, comparisons of various cooling tower technologies, strategies for water supply from different sources and an examination of the available options for the disposal of effluent water from the filters and cooling towers.

**Speaker:** Inigo Martin Melero (CERN)

**2:15 PM** **Heat recovery perspectives with CO<sub>2</sub>** 🕒 22m

A novel CO<sub>2</sub>-based architecture to recover, transport, and utilise surplus thermal energy across eight distributed sites is proposed as The Waste Heat Supply System (WHSS) for the Future Circular Collider (FCC).

The WHSS applies CO<sub>2</sub> in pressurised pipelines to transfer heat to decentralised heat pump - chiller units, where heat is delivered to end users and the CO<sub>2</sub> is liquefied.

Key optimisation strategies include: a) shifting FCC operational schedules to align with seasonal heat demand, b) transfer of surplus heat between surface sites via the tunnel, c) providing direct expansion AC with CO<sub>2</sub> inside the entire tunnel, and d) buffering heat through Borehole Thermal Energy Storage (BTES) for weekly-to-seasonal load balancing.

Case studies show these strategies significantly reduce cooling tower demand and eliminate entirely cooling water transport and consumption. Compared to conventional water-based systems, the CO<sub>2</sub>-based approach enables more compact infrastructure, higher delivery temperatures, and efficient heat recovery at multiple decentralised locations.

**Speaker:** Prof. Armin HAFNER (NTNU)

1



19-23 MAY  
**FCC WEEK**  
2025



**NTNU**  
Norwegian University of  
Science and Technology





# Heat recovery perspectives with CO<sub>2</sub>

by Prof. Dr.-Ing. Armin Hafner



Department of Energy and Process Engineering, NTNU

2

# Outline of presentation

1. Motivation
2. Optimisation of Utilisation Rates
3. Waste Heat Supply System with CO<sub>2</sub> heat transfer medium
4. Waste Heat Supply System with H<sub>2</sub>O heat transfer medium
5. Pipeline pressure drop and diameter calculations
6. Composite material instead of steel?
7. Concept for delocalisation of heat
8. Concept for buffering: Borehole Thermal Energy Storage
9. Concept for heat rejection
10. Case Study for Site A & B
11. Summary

# Motivation – potential

- **Recover – utilize thermal energy**
- **Align heat availability** with demand
- **Enable surplus heat export to end users/society**
- **Energy efficiency gain for society:**
  - **avoid Fossil Fuel** and **reduce Electricity** demand at the customer end
- **Reduce – eliminate cooling tower water consumption**

Site PA – Ferney-Voltaire

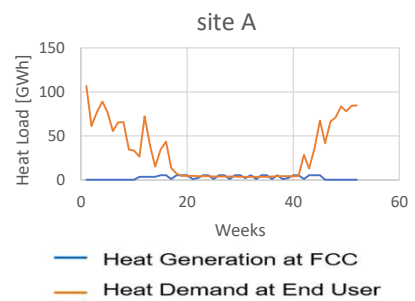
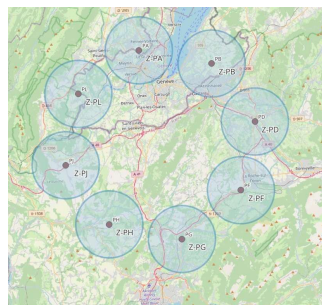
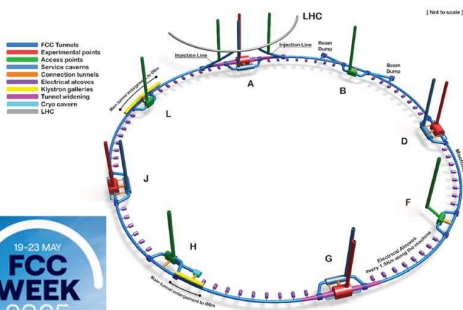
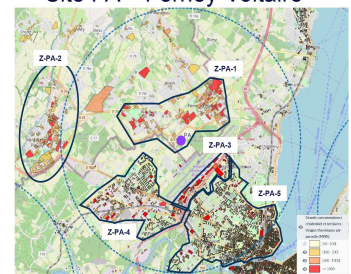

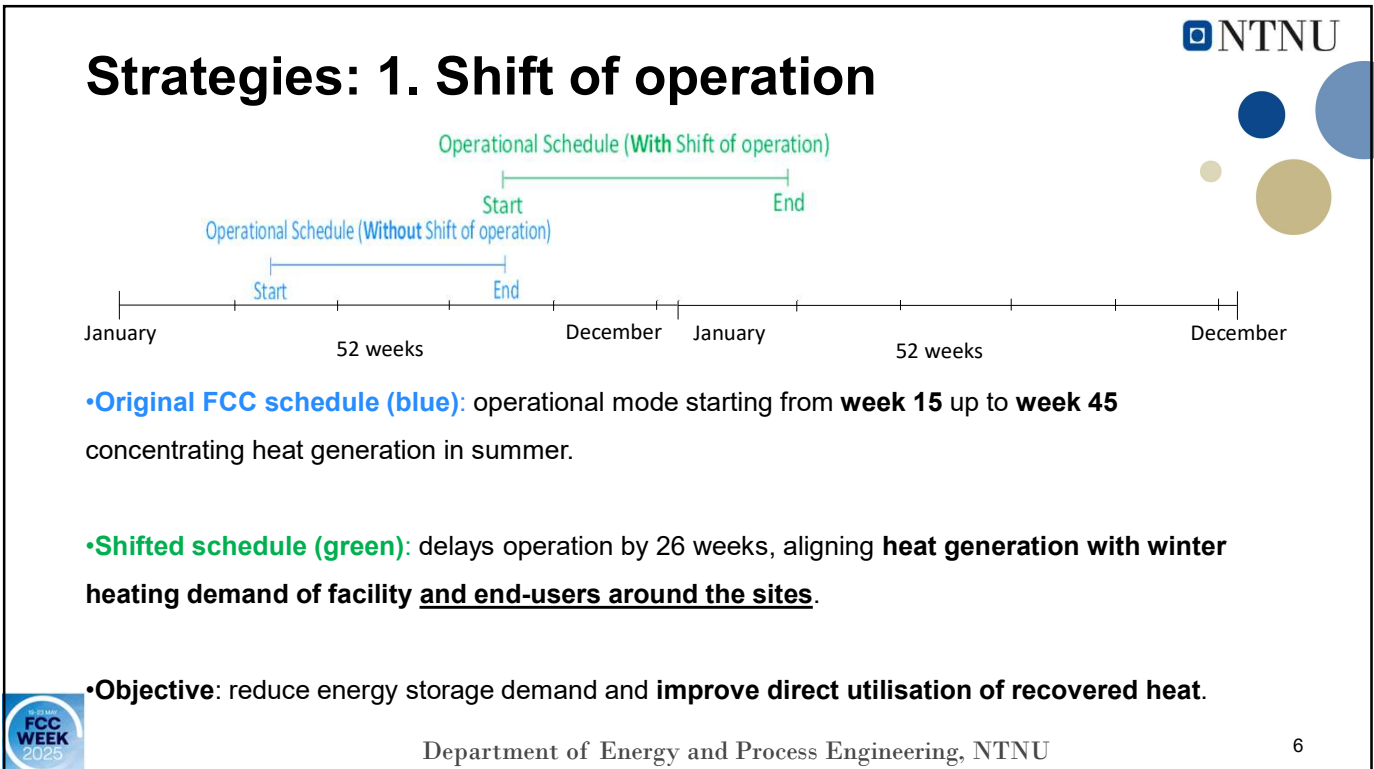
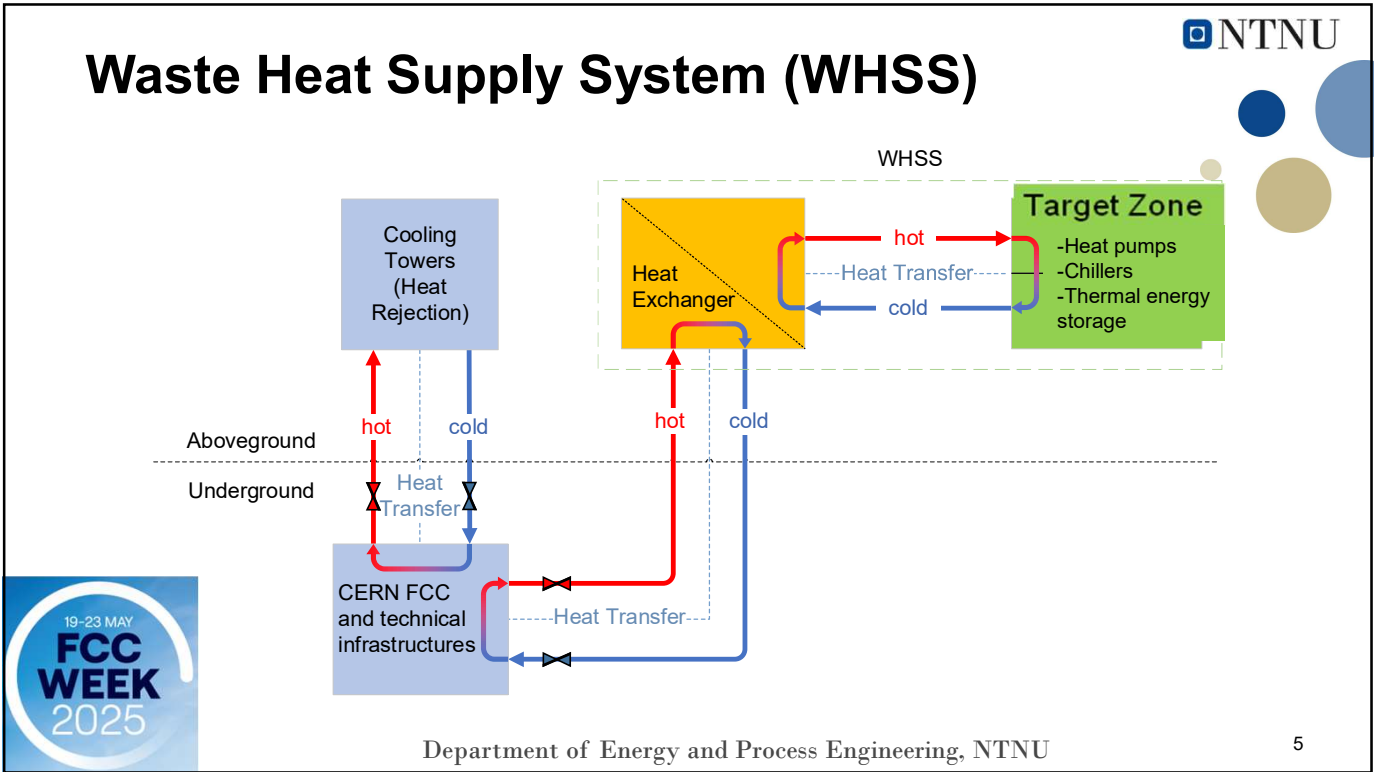

# Strategies: 1. Shift of operation

With and without *Shift of Operation* for site A, mode tt, year 1

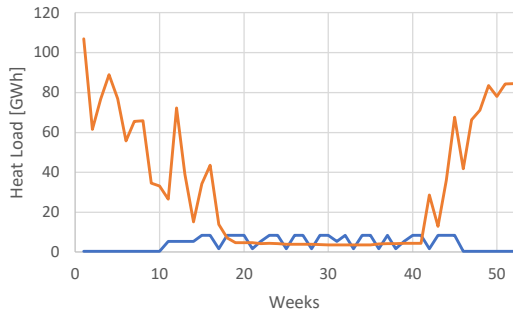

Without shift of operation

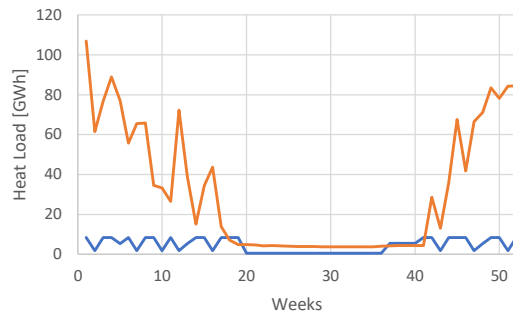

With shift of operation

- Heat Generation at FCC
- Heat Demand at End User



# Strategies: 1. Shift of operation

With and without *Shift of Operation* for site D, mode tt, year 1

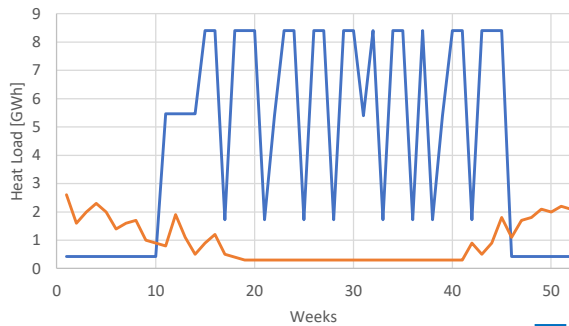

Without shift of operation

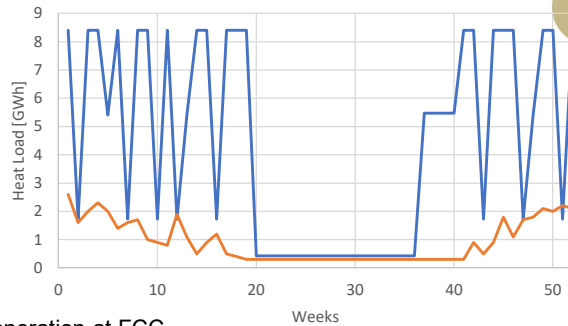

With shift of operation

- Heat Generation at FCC
- Heat Demand at End User



## Strategies: 2. Delocalisation (transfer)

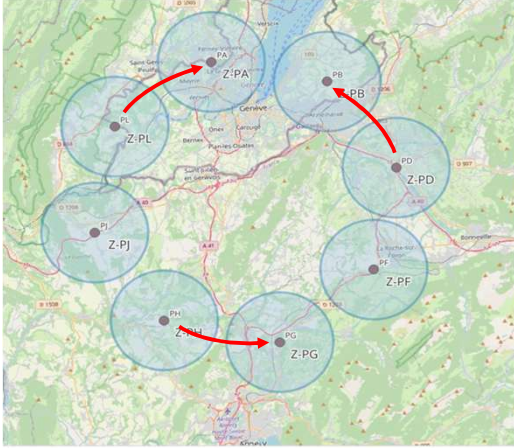

- Delocalisation of heat:

D → B

H → G

L → A

- further increasing the heat utilisation



## Strategies: 3. Buffering (thermal storage)

Site B – Base + Delocalisation + Shift of operation in mode tt

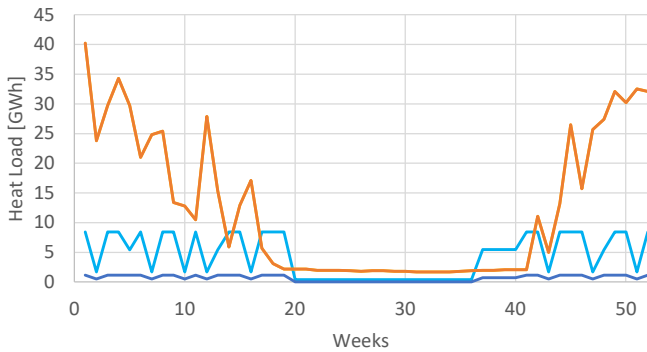

- Delocalisation and shift of operation reduce the mismatch between heat supply and demand

→ Residual mismatch still exists

- Buffering through Thermal Energy Storage is required to store surplus heat to be supplied to end-users during service days etc.**

- Heat Generation at site D transferred to site B
- Heat Generation at site B
- Heat Demand at End User



# Impact of Shift of Operation, Delocalisation and Buffering on Heat Utilisation

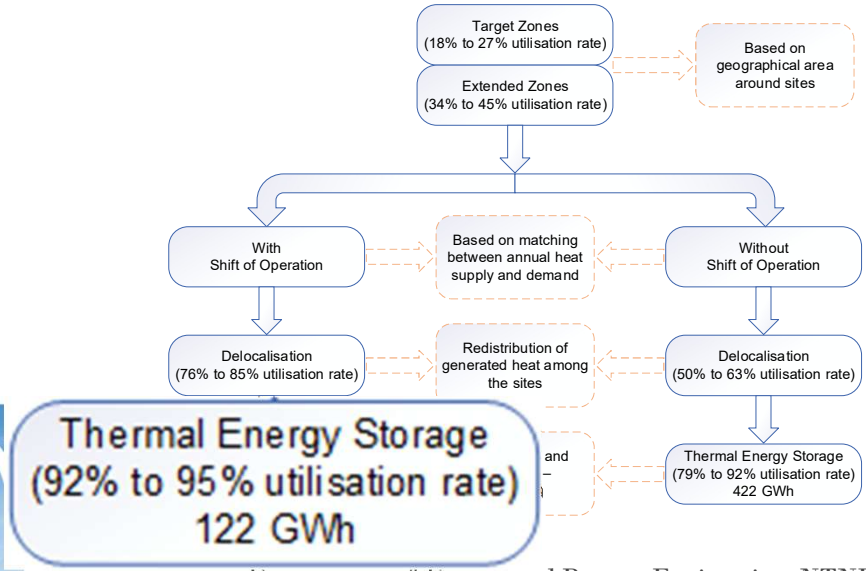

# From Strategy to System: WHSS Concept, Architecture, and Results



# Waste Heat Supply System (WHSS) with CO<sub>2</sub> as heat transfer medium

## Why CO<sub>2</sub>?

- Global Warming Potential (GWP) GWP of 1
- Zero Ozone Depletion Potential (ODP)
- Non-flammable and non-toxic
- **CO<sub>2</sub> is inexpensive and widely available**
- Meets regulations
  - EU F-Gas Regulation
  - Kigali Amendment to the Montreal Protocol
- Operate at higher pressures - compact system designs
- Highly effective in heat pumps, particularly for producing high-temperature water



# Concept: WHSS with CO<sub>2</sub> as heat transfer medium

WHSS = Waste Heat Supply System

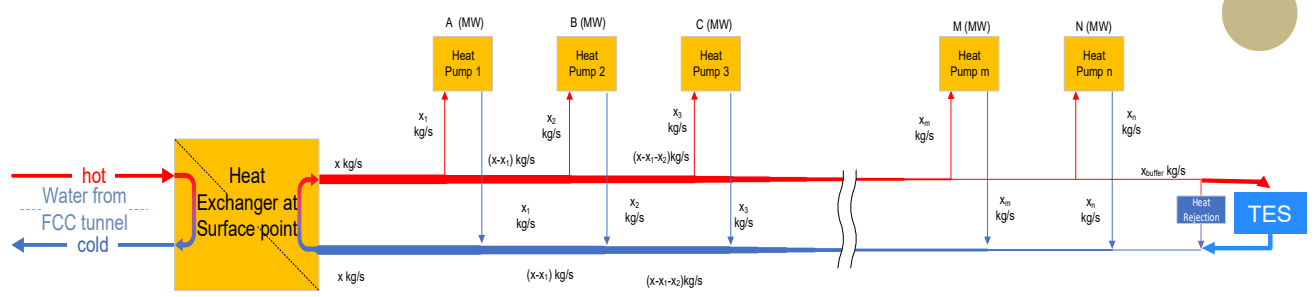

- At the surface point, the **heat is exchanged from water to CO<sub>2</sub>** through heat exchangers.
- CO<sub>2</sub> vaporized in Heat Exchanger, and gas flows through long pipelines to the target zones
- A portion of the gas is diverted to each heat pump/chiller
- The **heat pump transfers the heat from the CO<sub>2</sub> to the process stream of end user**, CO<sub>2</sub> is liquefied
- The heat pumps are designed to ensure that the mass flow entering and exiting the unit remains balanced.



# CO<sub>2</sub> heat transport pipelines

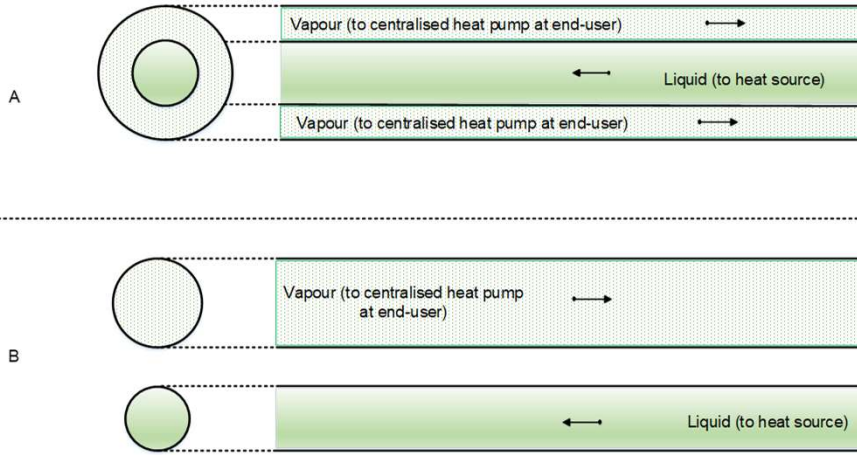

# CO<sub>2</sub> heat transport pipelines (equal size)

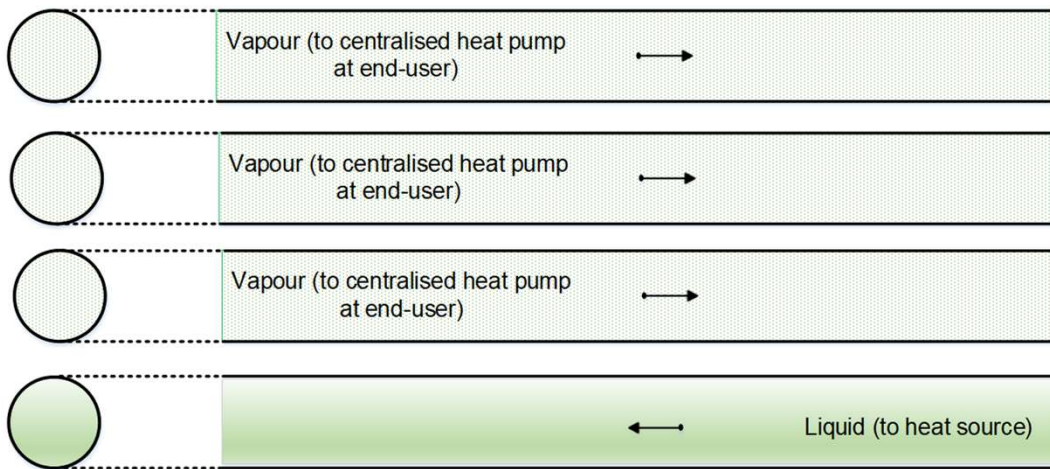

### Possible configurations of heat pumps at surplus end user zones

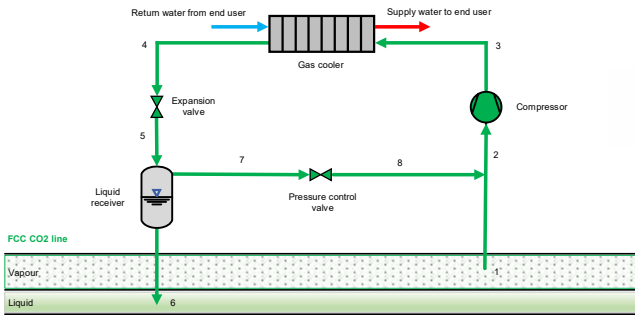

Transcritical CO<sub>2</sub> cycle

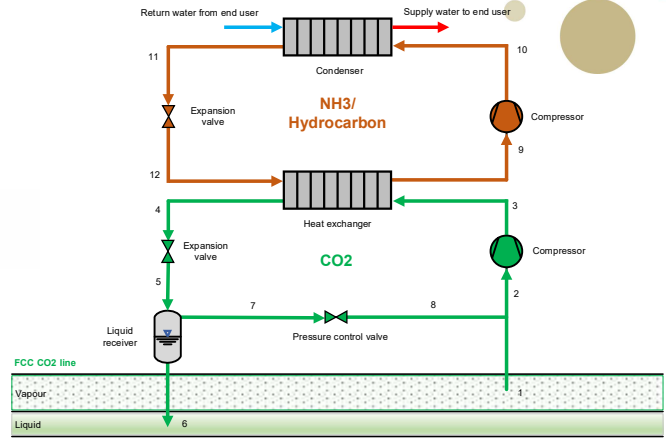

Cascade CO<sub>2</sub> and NH<sub>3</sub>/Hydrocarbon cycle



### Energy efficiency gain by using heat pumps of WHSS

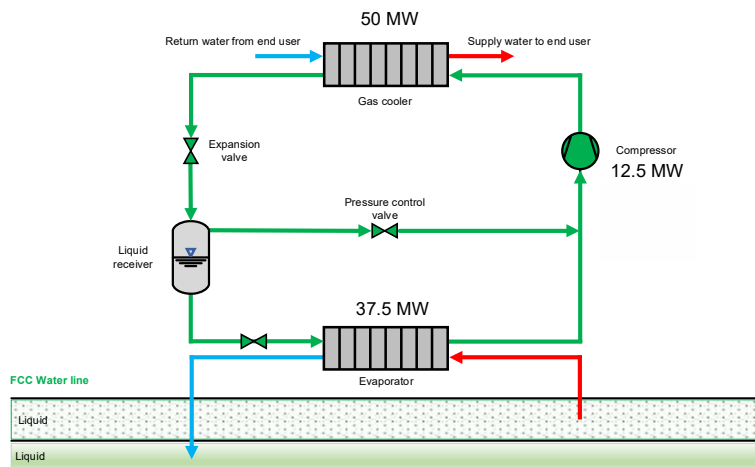

25 °C, in 65 °C, out  
 Q = 50 MW electricity

- Instead of 50 MW the end user only needs to come up for 12.5 MW (COP = 4 for heat pump)
- Electricity production at 5% from fossil fuels
- 28 t CO<sub>2</sub> per day for electric boiler
- 7 t CO<sub>2</sub> per day for CO<sub>2</sub> heat pump



# Real examples for market ready heat pump components



Alfa Laval, plate heat exchanger



SWEP, gas cooler



Danfoss, expansion valve



Bitzer, compressor

xx kW



MAN Energy Solutions, compressor

xx MW

Department of Energy and Process Engineering, NTNU



# WHSS with H<sub>2</sub>O heat transfer medium - Concept



WHSS = Waste Heat Supply System

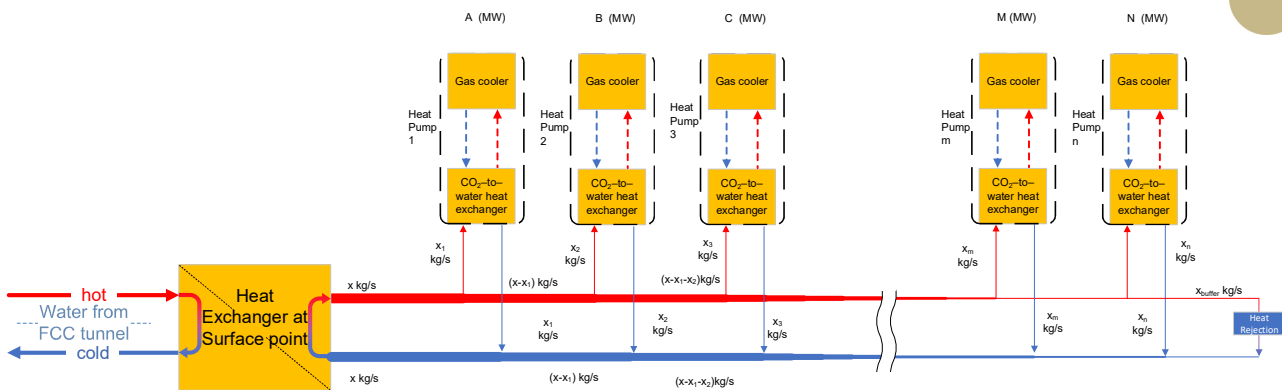

Department of Energy and Process Engineering, NTNU

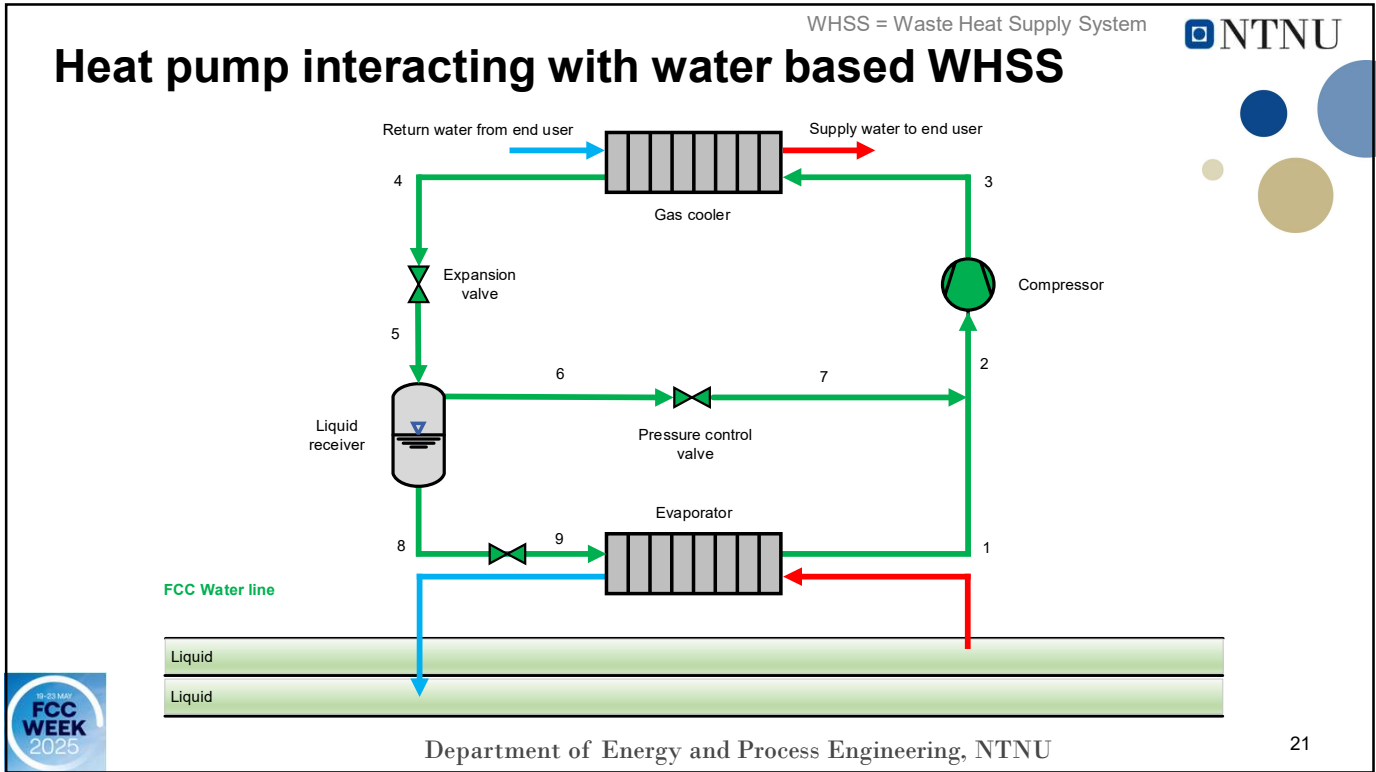

## Pipeline pressure drop and diameter calculations:

### Data and assumptions

Parameter	Data	Remarks
Entry temperature of water from FCC	45°C	Value confirmed by CERN
Return temperature of water to FCC	27°C	Value confirmed by CERN
Maximum heat rejected from site A	50 MW	Data provided CERN
No of heat pump in WHSS	2	Unknown. Assumed for simplicity.
Heat supply to end user through one heat pump	25 MW	Unknown. Assumed for simplicity.
Entry temperature of end user heat sink (water)	25°C	Unknown. Assumed for simplicity.
Final temperature required by end user	65°C	Unknown. Assumed for simplicity.
Pipeline length between heat pumps	5000 m	Unknown. Assumed for simplicity.
Effect of pipeline elevation, bends etc	Neglected	Assumed for simplicity.

Site A, D, G, J

Mode of Operation	Abbreviation	Power (Z) [MW]	Power (W) [MW]	Power (H) [MW]	Power (tt) [MW]	Number of weeks
Shutdown	SD	2.02	2.28	2.28	2.52	17
Commissioning	com	20.41	23.19	24.60	32.56	4
Operation	OP	31.41	34.07	38.93	50.00	20
Downtime	DT	5.34	6.15	6.96	10.28	6
Technical Stop	TS	5.34	6.15	6.96	10.28	2
Machine Development	MD	13.56	16.23	21.07	32.16	3

Site PA – Ferney-Voltaire

Department of Energy and Process Engineering, NTNU

# Pipeline pressure drop and diameter calculations: CO<sub>2</sub> based WHSS (Waste Heat Supply System)

for 5km pipe length:

- $\Delta p = 1\text{bar}$
- $\Delta p = 2\text{bar}$
- $\Delta p = 3\text{bar}$

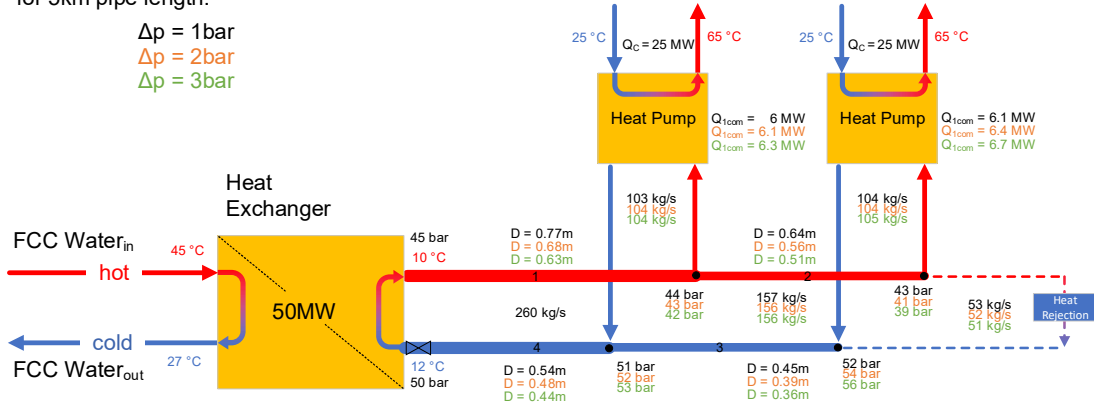

Alternative: multiple pipelines



# Pipeline pressure drop and diameter calculations: H<sub>2</sub>O based WHSS

for 5km pipe length:

- $\Delta p = 1\text{bar}$
- $\Delta p = 2\text{bar}$
- $\Delta p = 3\text{bar}$

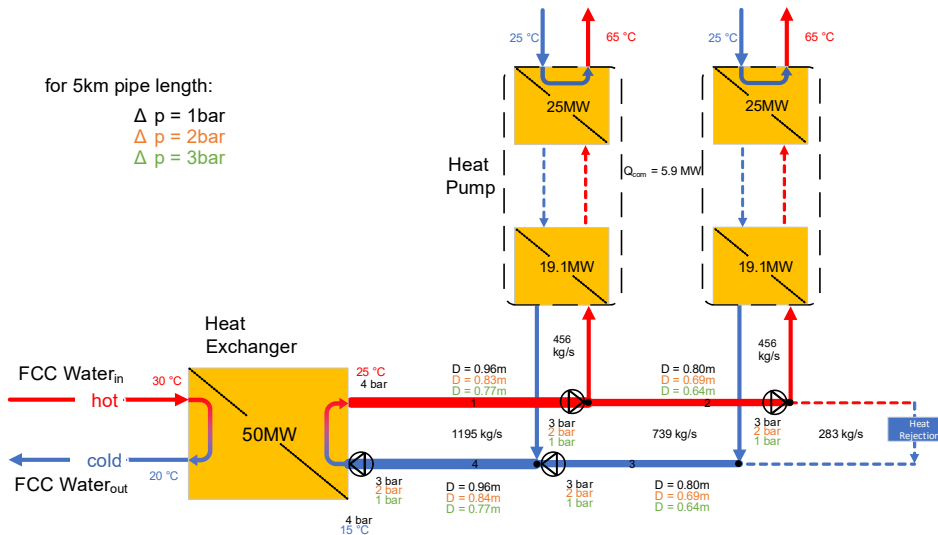

# Pipeline pressure drop and diameter calculations: Comparison between CO<sub>2</sub> and H<sub>2</sub>O based systems

Working fluid	Δp in 5 km [bar]	Pipe segment	Diameter [m]	Volume Flow [m <sup>3</sup> /s]	Total Pump Power [MW]	Heat pump compressor power [MW]	Total Power [MW]	Pipe thickness [mm]	Steel Mass per Meter [kg/m]	Total mass of steel [ton]
2	0.56	1.19	7.05	98.53						
3	0.39	0.18	5.47	53.32						
4	0.48	0.3	6.73	80.77						
Water	2	1	0.83	0.6	0.8	11.8	12.6	0.91	18.59	316.71
		2	0.69	0.37				0.75	12.85	
		3	0.69	0.37				0.75	12.85	
		4	0.84	0.6				0.92	19.05	



## Composite material instead of steel? No - costwise

### MILL & WELDING CAPABILITIES



2.375" to 18" OD



Wide range of steel grades with homogeneous fine-grained steel microstructure for superior mechanical properties



Tight pipe-end out-of-roundness tolerances (ID & OD)

Seamless →  
Ø 60 mm  
to  
Ø 457 mm



We offer the largest dimensional range of seamless line pipe



And we can weld even larger diameters



# CO<sub>2</sub> pipeline options – of the shelf



Not to be disclosed without Vallourec permission

## CCS – Dense CO<sub>2</sub> transport Track Record : Qatar Petroleum / Galfar

*Project Name : CO<sub>2</sub> Water Alternating Gas Pilot Project*  
*Dense phase is ideal for transporting CO<sub>2</sub> and injecting it into crude oil reservoirs for enhanced oil recovery*  
*Location: Dukhan (Qatar)*  
*FEED: SLB ; TechnipFMC*  
*Main Contractor: Galfar*

- VALLOUREC delivered :**
- Delivery of 136 km of Linepipe
  - 406,4 x 20,62 X65QS with good toughness low temperature
  - FBE+ External Coating

136 km

Ø 406 x 20 mm



2024 Group Presentation

12



# CO<sub>2</sub> pipeline options – of the shelf



## VALLOUREC EXPERTISES: SEAMLESS PIPES AND SERVICES FOR SAFE CO<sub>2</sub> TRANSPORT AND SEQUESTRATION

### SAFE CO<sub>2</sub> TRANSPORT PROJECT IN WYOMING



#### OFFER CO<sub>2</sub> PIPELINE

- Seamless Onshore and Offshore pipeline including bends
- OD: from 2" to 18"
- WT upto 50 mm
- Coating FBE & Thermal Insulation
- Welding Services: Serimax®



**FIT FOR PURPOSE AND QUALIFIED SOLUTION FOR CCUS INFRASTRUCTURE**

# Examples in CH

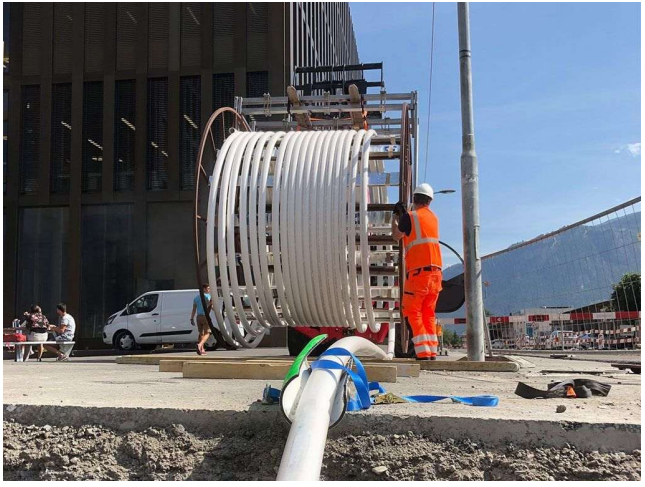

District Heating in Sion, Switzerland using CO<sub>2</sub>

Source: [Using CO<sub>2</sub> to heat and cool urban areas - Exergo](#)



# Concept for delocalisation of heat

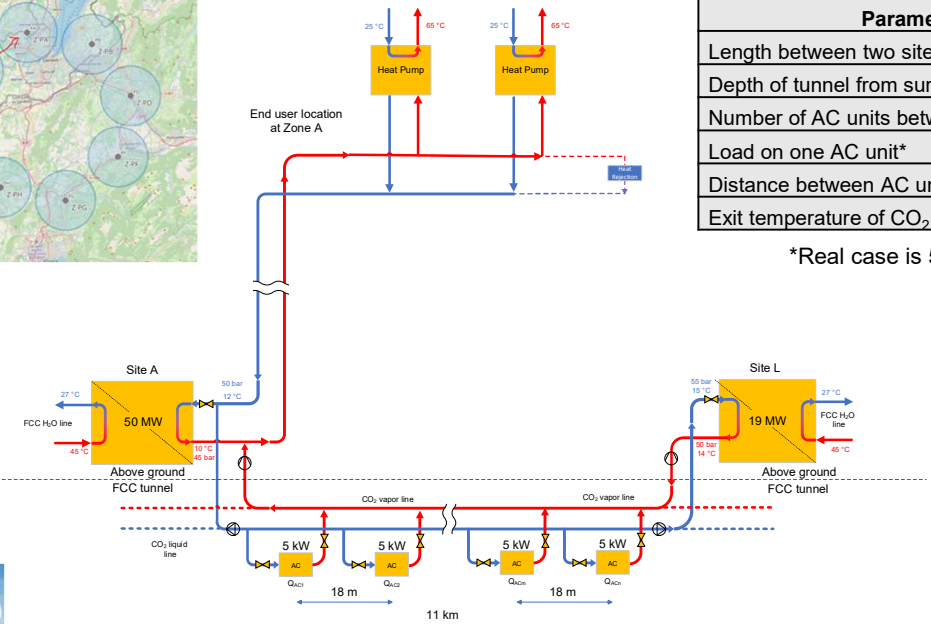
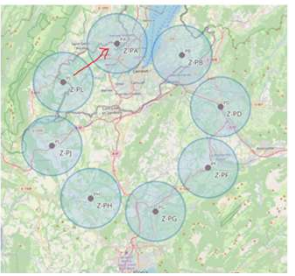

Parameter	Data
Length between two sites	11 km
Depth of tunnel from surface	200 m
Number of AC units between sites*	3
Load on one AC unit*	1 MW
Distance between AC units*	2.75 km
Exit temperature of CO <sub>2</sub> from evaporator	15°C

\*Real case is 5 kW evaporator every 18m.



# Concept for delocalisation of heat

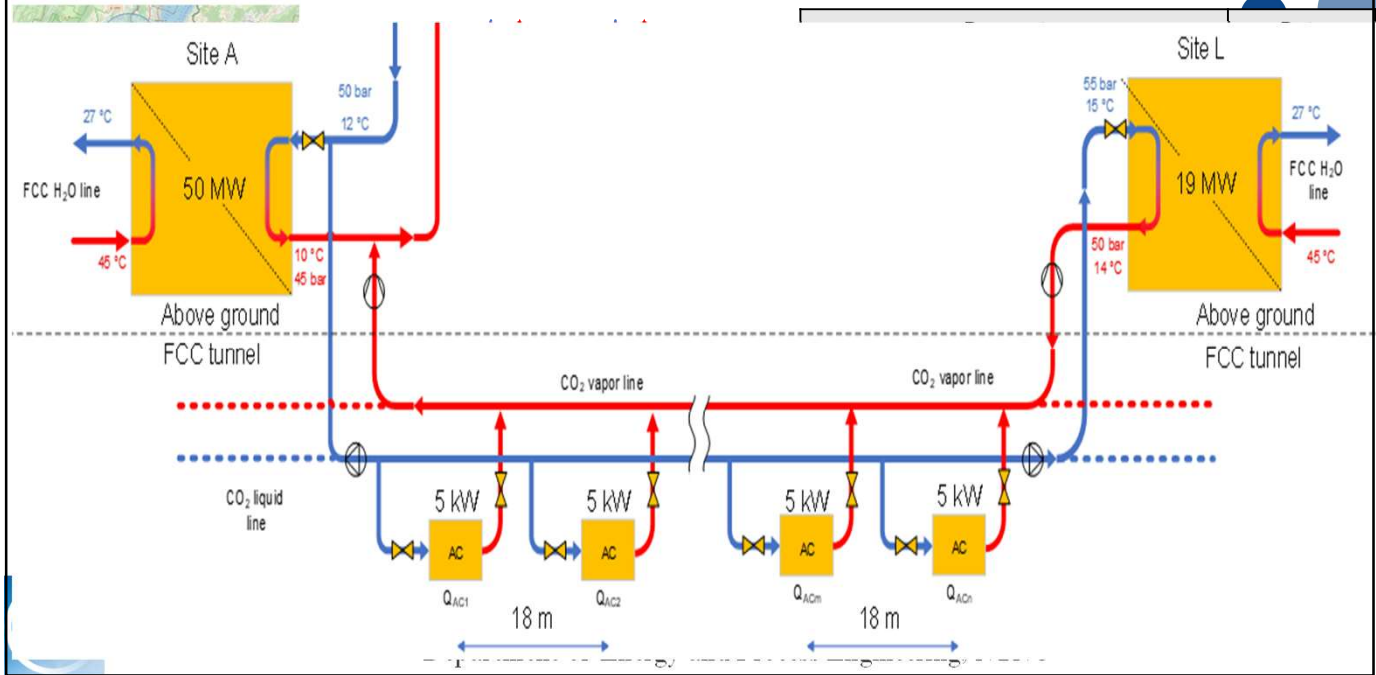

31

## Delocalisation / transfer of heat Pressure drop and diameter calculations

fixed diameter (maximum pressure drop 2 bar)

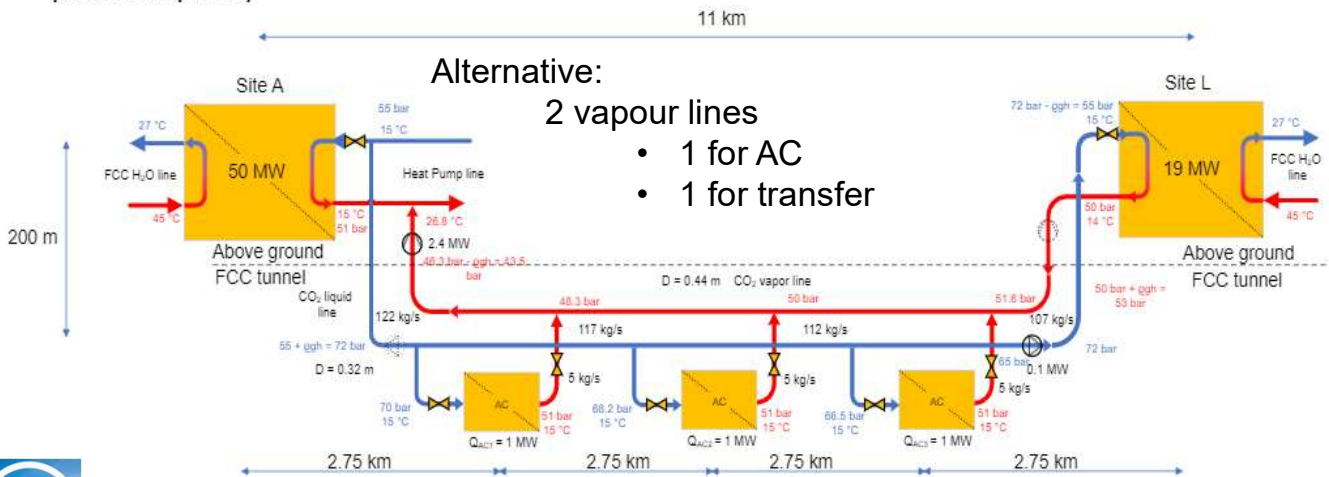

32

# Case study: Only air conditioning inside the tunnel

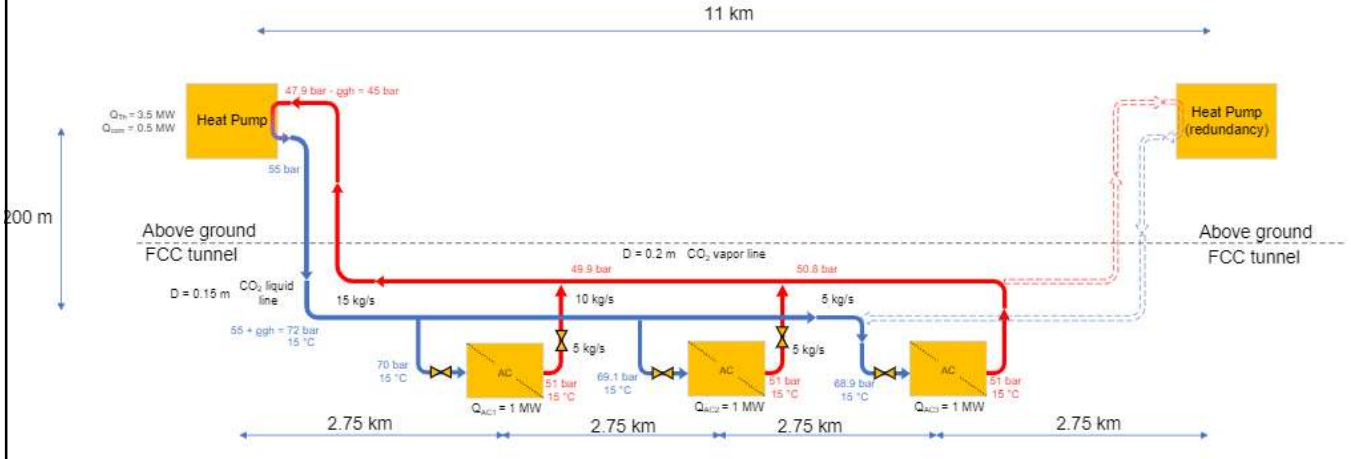

# Concept for heat buffering: Borehole Thermal Energy Storage (BTES)

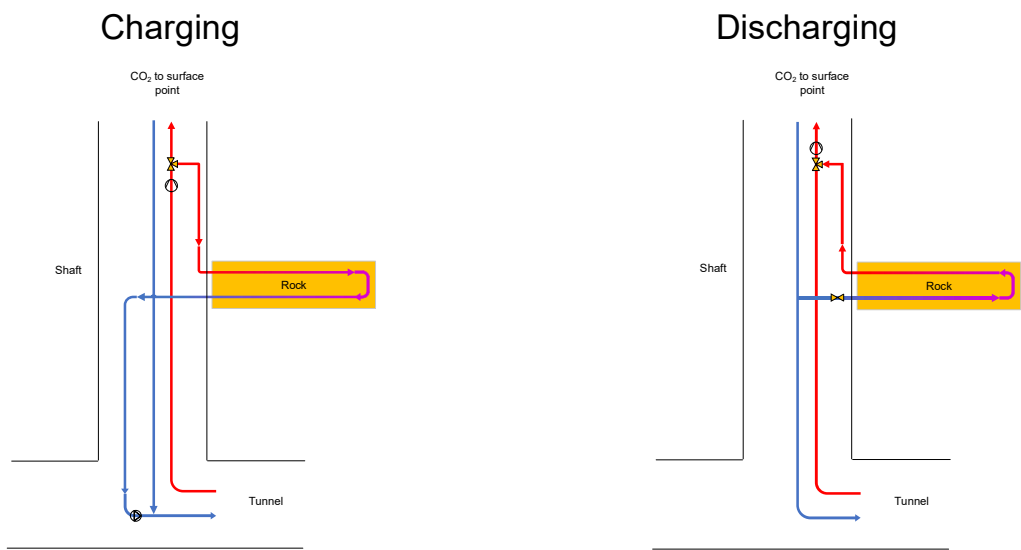

**Concept for buffering: Borehole heat exchanger concept**

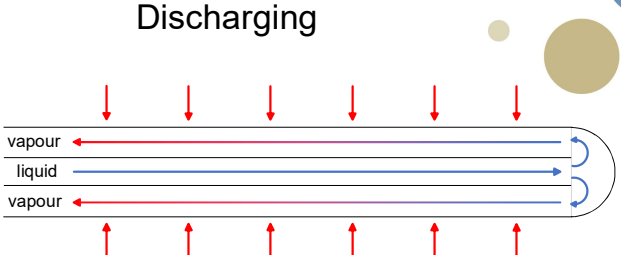
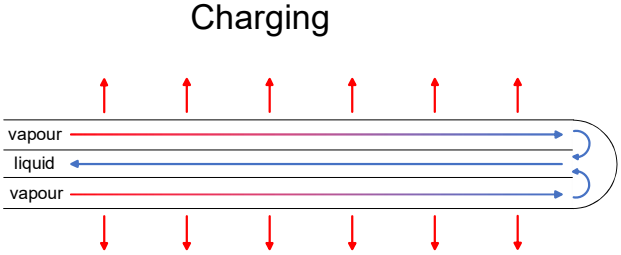

*Case study*

Length: 200 m per pipe  
 Diameter: 0.12 m  
 Heat Load per pipe: 6kW

Heat that needs to be rejected determines the number of pipes



**Inclined BTES with multiple underground ring elements**

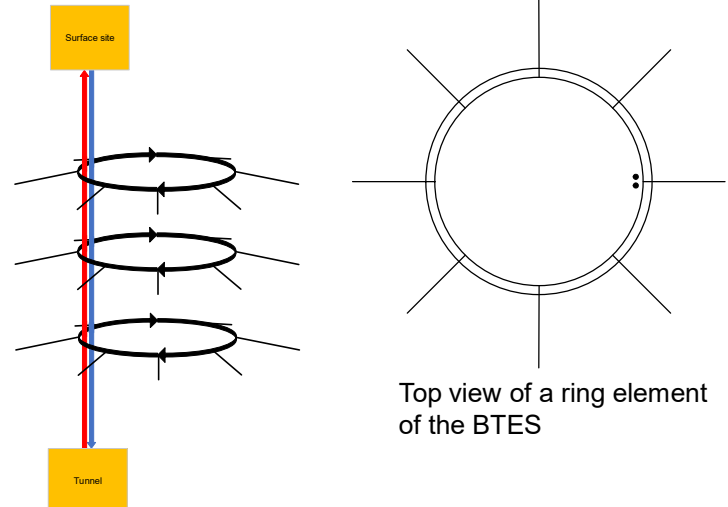

Schematic representation of a BTES system with multiple rings with bore hole heat exchangers.

- Inclined boreholes form concentric underground rings around the FCC tunnel to maximise contact with rock for heat storage
- A central vertical shaft connects the surface to each ring, circulating heat transfer fluid through separate liquid and vapour lines

(BTES) Borehole Thermal Energy Storage



# Borehole Temperature Evolution

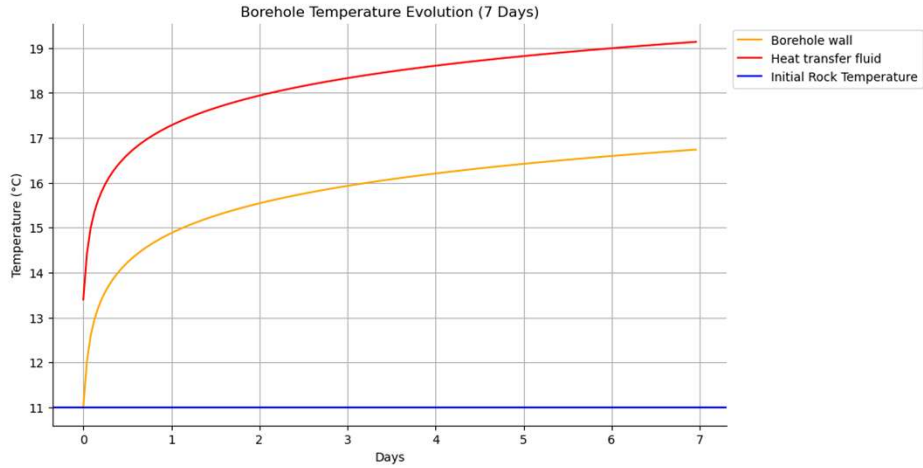

Department of Energy and Process Engineering, NTNU

37

37

# BTES CO<sub>2</sub> Charging Process (1 Day)

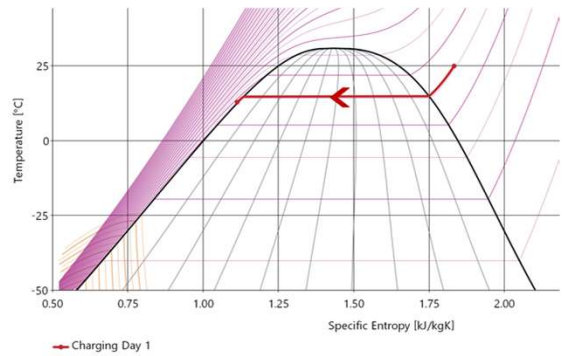
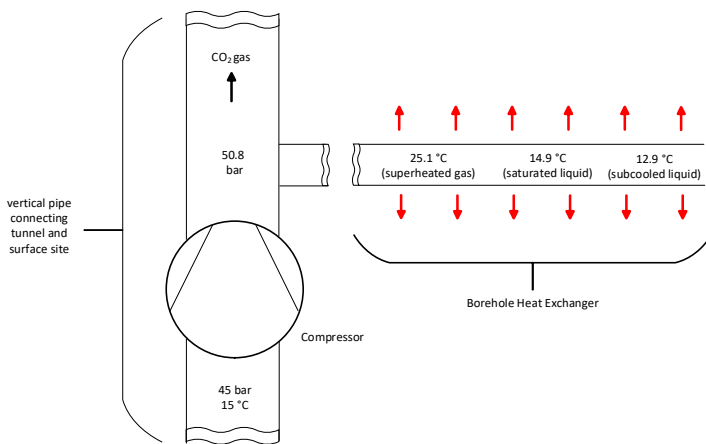

(BTES) Borehole Thermal Energy Storage

Department of Energy and Process Engineering, NTNU

38



38

# BTES CO<sub>2</sub> Discharging Process (1 Day)

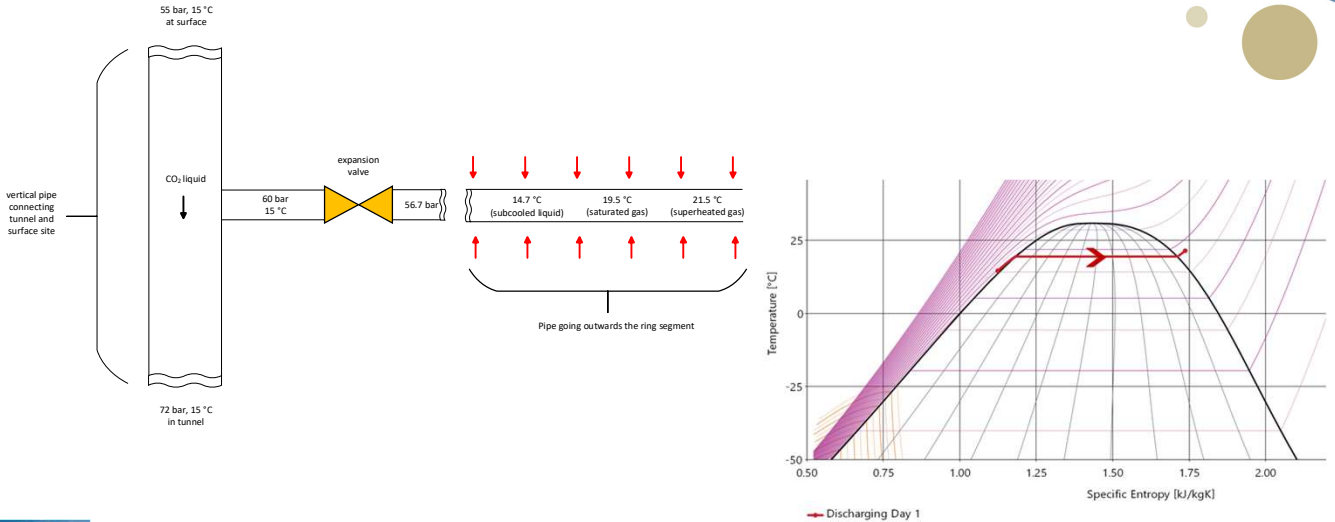

Department of Energy and Process Engineering, NTNU

# BTES CO<sub>2</sub> Charging Process (7 Days)

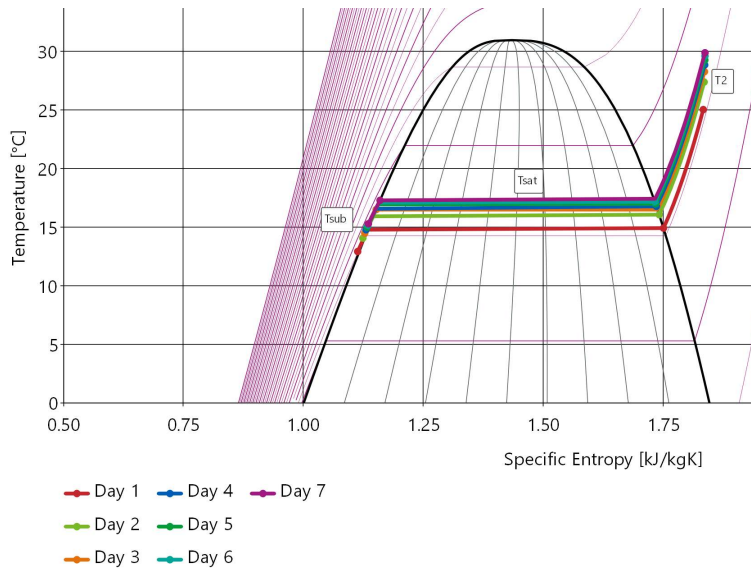

(BTES) Borehole Thermal Energy Storage

Department of Energy and Process Engineering, NTNU

# Concept for alternative heat rejection (heat source)

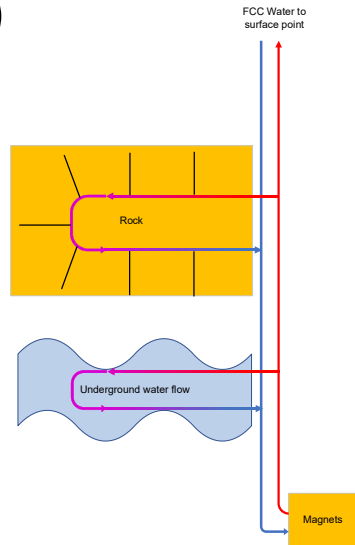

& heat storage for later export

location even outside the FCC area



# Heat generation and demand for Site A & B

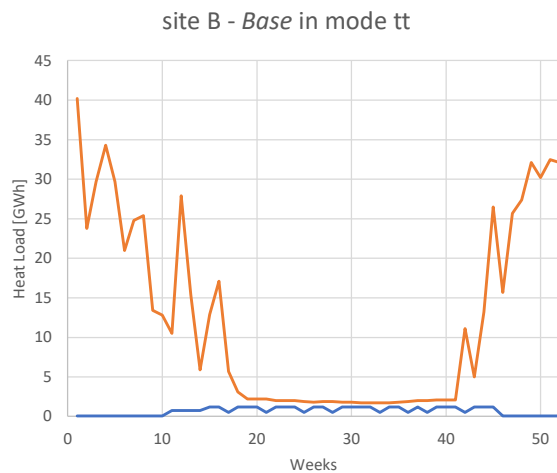
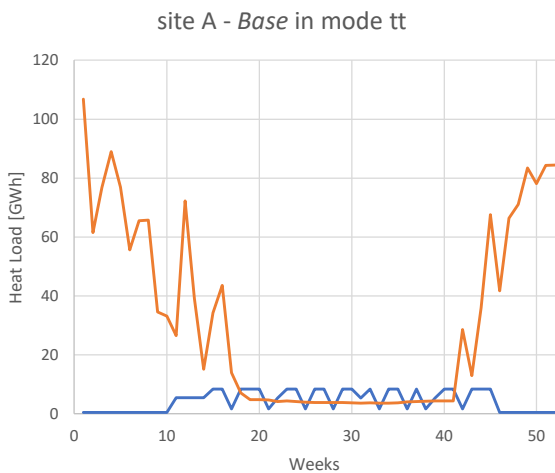

— Heat Generation at FCC  
 — Heat Demand at End User



# BTES for Site A & B

## BTES is not needed

- For site A in *Base + Delocalisation + Shift of operation case*

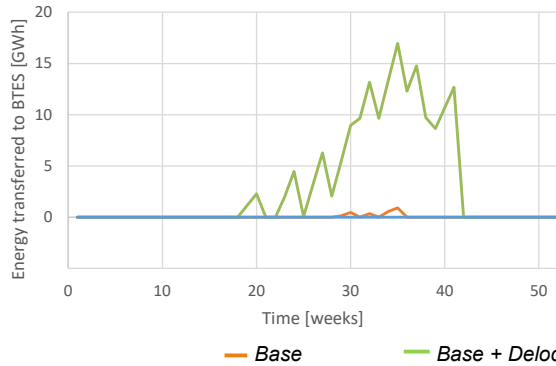

## BTES is needed for site B

- For Site B in *Base + Delocalisation + Shift of operation case*

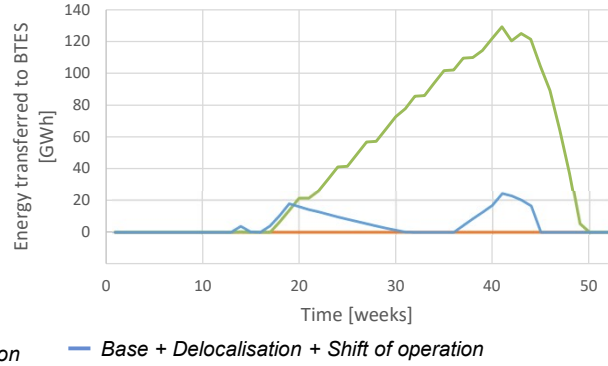

Department of Energy and Process Engineering, NTNU

43

43

# Comparison of BTES Capacity and Energy Storage for Base and Optimised WHSS Scenarios at Site A

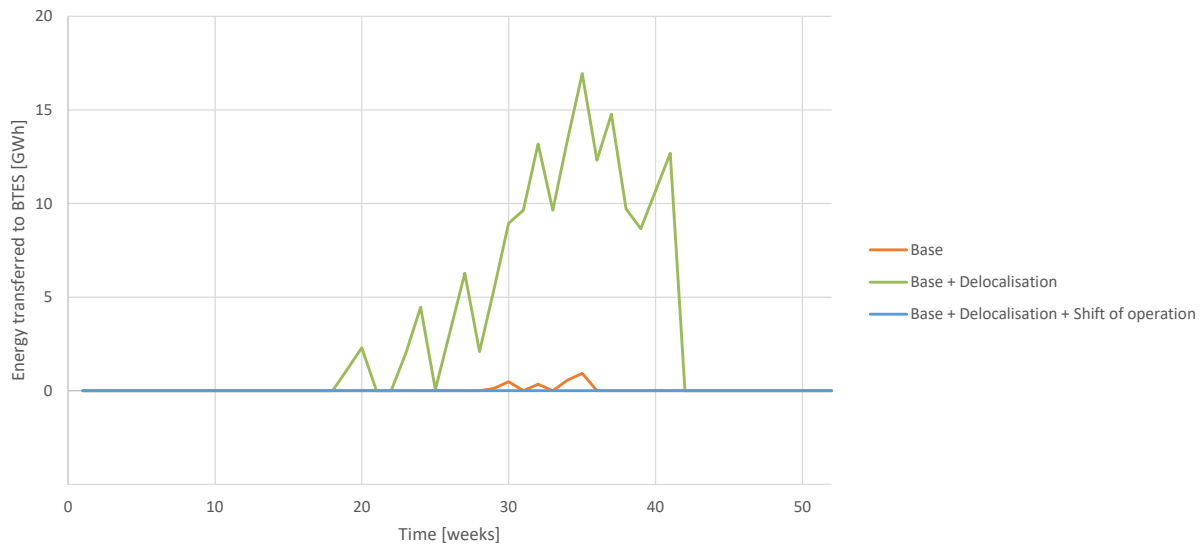

Department of Energy and Process Engineering, NTNU

44

44

### Heat Generation and Utilisation for Sites B and D for Base case in mode tt

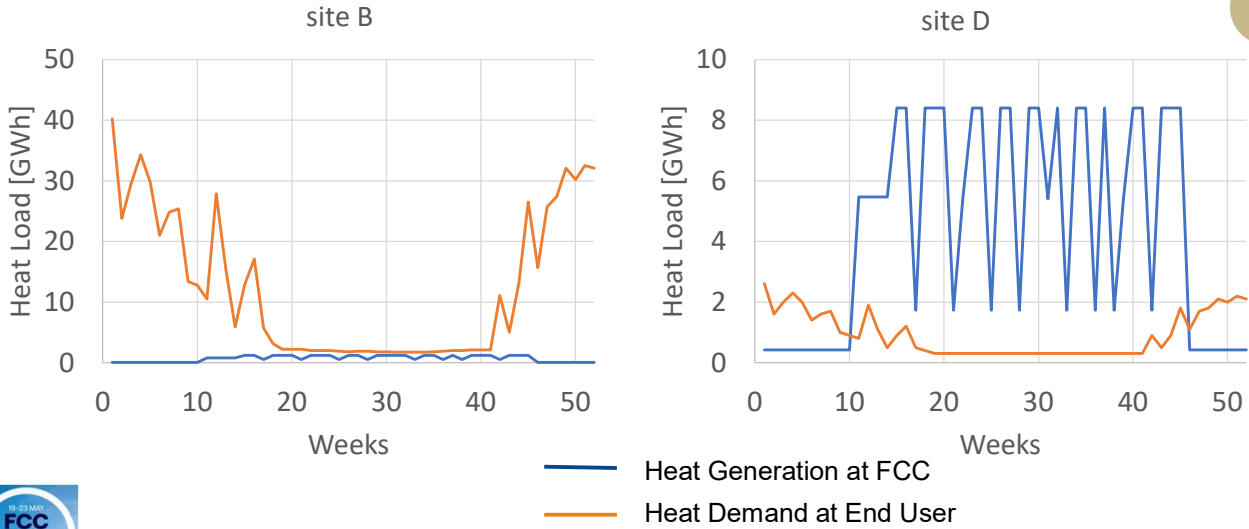

### Comparison of BTES Capacity and Energy Storage for Base and Optimised WHSS Scenarios at Site B for mode tt

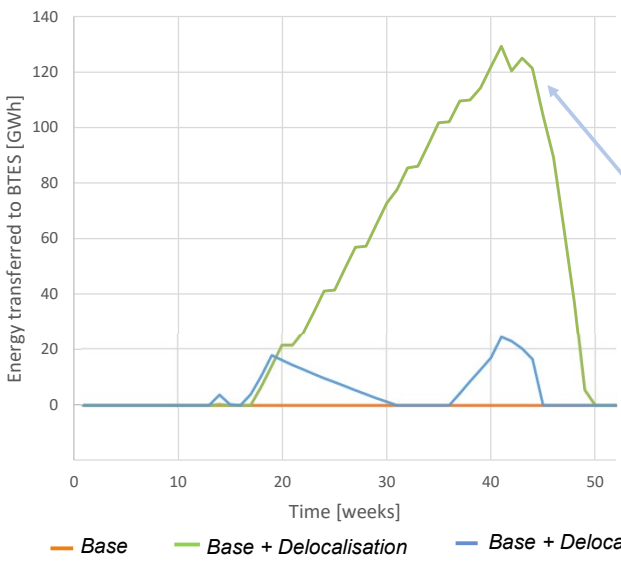

- **Base case** shows no storage demand — local demand is sufficient to absorb generated heat
- **Delocalisation** introduces a significant storage need delocalised from site D, peaking at ~130 GWh in week 41
- **Shift of operation** reduces and spreads the storage load, but ~20 GWh of BTES is still needed to manage seasonal imbalance.

WHSS = Waste Heat Supply System  
 BTES = Borehole Thermal Energy Storage



### Weekly BTES Energy Transfer and Impact on Cooling Tower Load at Site B for Base + Delocalisation + Shift of operation for mode tt

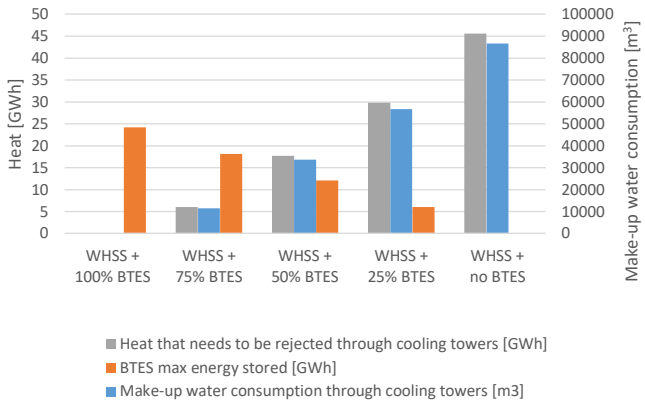
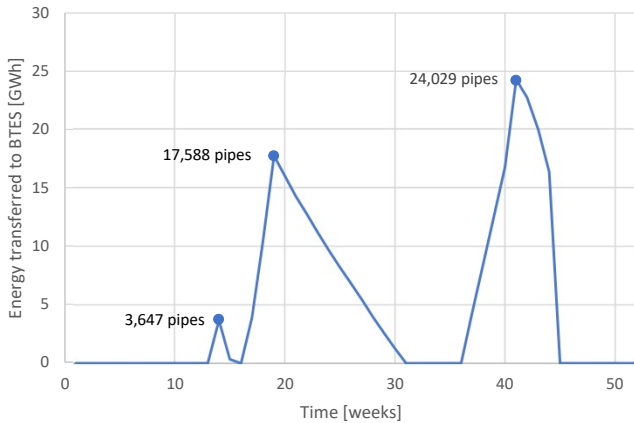

(BTES) Borehole Thermal Energy Storage



(BTES) Borehole Thermal Energy Storage

### Cooling Tower Water Demand under Varying BTES Coverage at Site B for mode tt

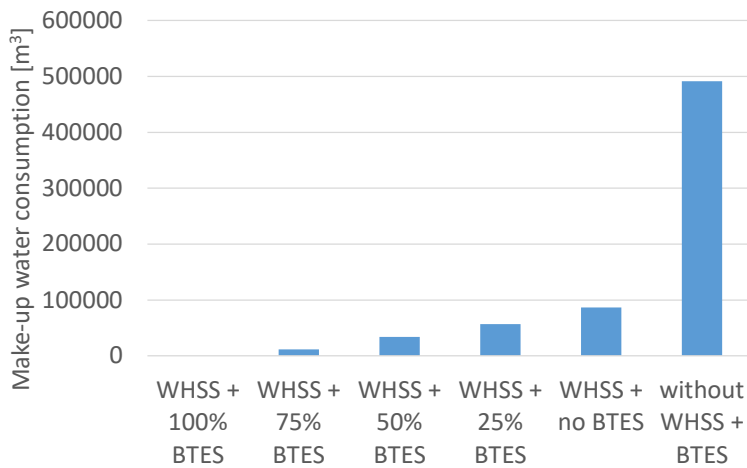

- Cooling tower demand decreases with increasing BTES capacity
- **Full BTES storage eliminates annual water use** (saves up to 491,000 m<sup>3</sup> (64,821 m<sup>3</sup> at site B, 426,952 m<sup>3</sup> at site D))
- Even without BTES, WHSS reduces water demand by over 400,000 m<sup>3</sup>/year for site B and D



# Summary



- Advantages
  - **Eliminate water use** and transport for cooling purpose (cooling towers)
  - Implement **energy efficient AC** (direct expansion) in the tunnel
  - High heat utilisation ratio and redundancy in the external heat distribution network
  - CO<sub>2</sub> / CCS infrastructure network
  - Provide cooling (**AC**) with the external CO<sub>2</sub> infrastructure during summer months (district cooling)
- Identified Challenges / Opportunities
  - Is FCC **ready to perform operation from Oct to Mar** → to become a valuable heat source in winter?
  - Heat rejection network – **cooling as a service for FCC** from the distribution network operators
- Technology gaps
  - alternative **pipeline concepts** – optimization / sizing of CO<sub>2</sub> transport lines (internal and external)
  - horizontally inclined **Borehole Thermal Energy Storage with CO<sub>2</sub>** as heat transfer fluid
  - Safety assessment of **efficient and compact DX-CO<sub>2</sub> AC inside the tunnel** – versus chilled water pumping

Department of Energy and Process Engineering, NTNU

49

49

Thank you for your attention!  
Questions are welcome.

Contact:

[armin.hafner@ntnu.no](mailto:armin.hafner@ntnu.no)  
[+47 92857730](tel:+4792857730)

Team at NTNU:

Dr. Sarun Kumar Kochunni  
[sarun.k.kochunni@ntnu.no](mailto:sarun.k.kochunni@ntnu.no)

Mr. Quentin Rene Liebsch  
[quentirl@stud.ntnu.no](mailto:quentirl@stud.ntnu.no)



Norwegian University of  
Science and Technology

Department of Energy and Process Engineering, NTNU

50

50

# Backup

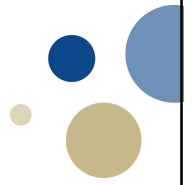

51

## Comparison of BTES Capacity and Energy Storage for Base and Optimised WHSS Scenarios at Site L

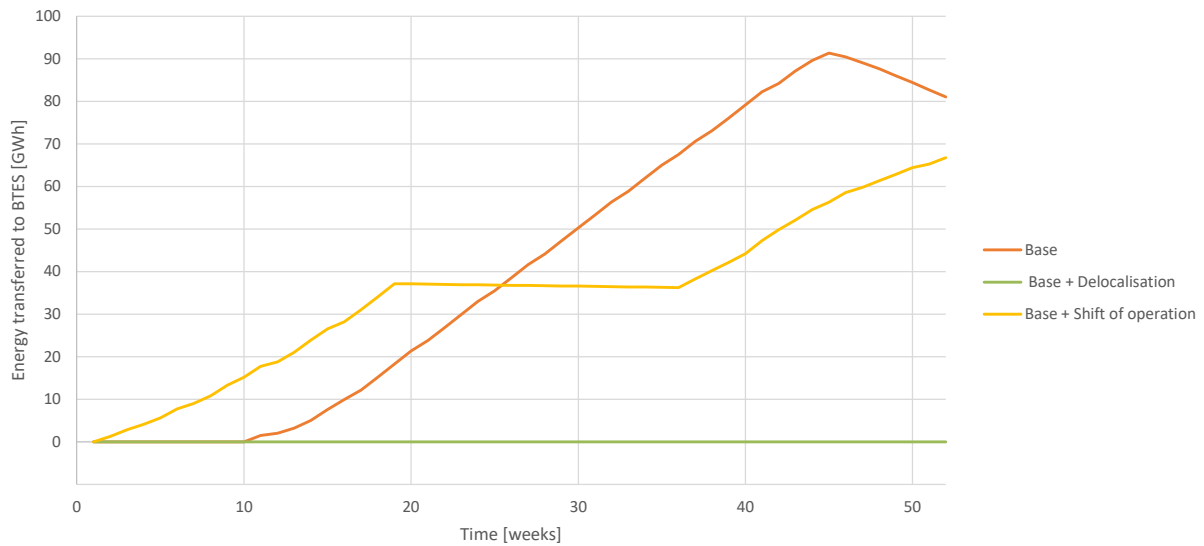
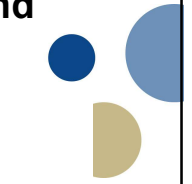

52

### Comparison of BTES Capacity and Energy Storage for Base and Optimised WHSS Scenarios at Site D

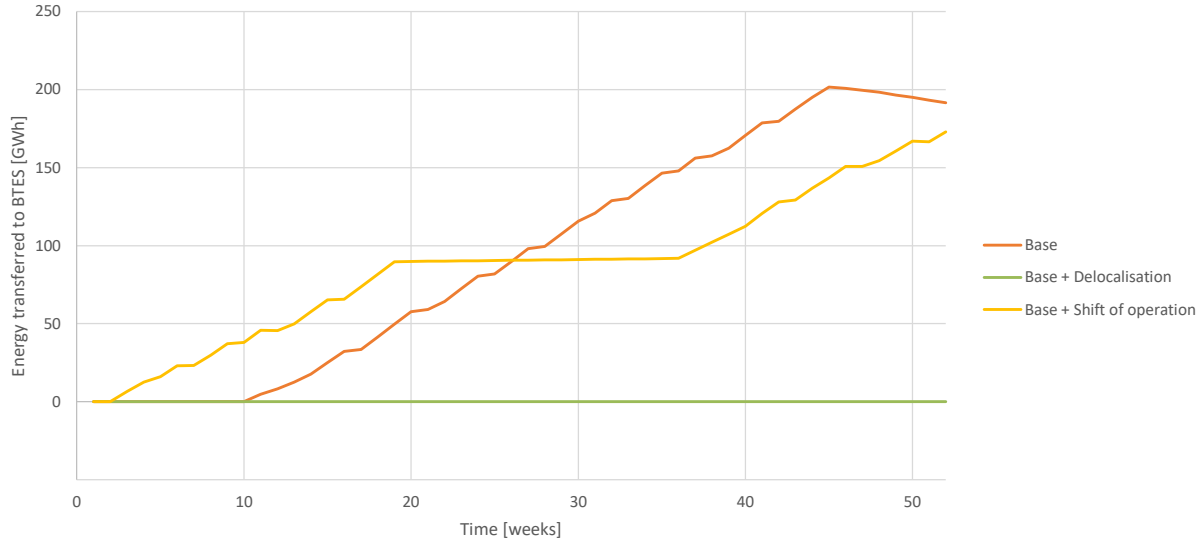

Department of Energy and Process Engineering, NTNU

### Comparison of BTES Capacity and Energy Storage for Base and Optimised WHSS Scenarios at Site F

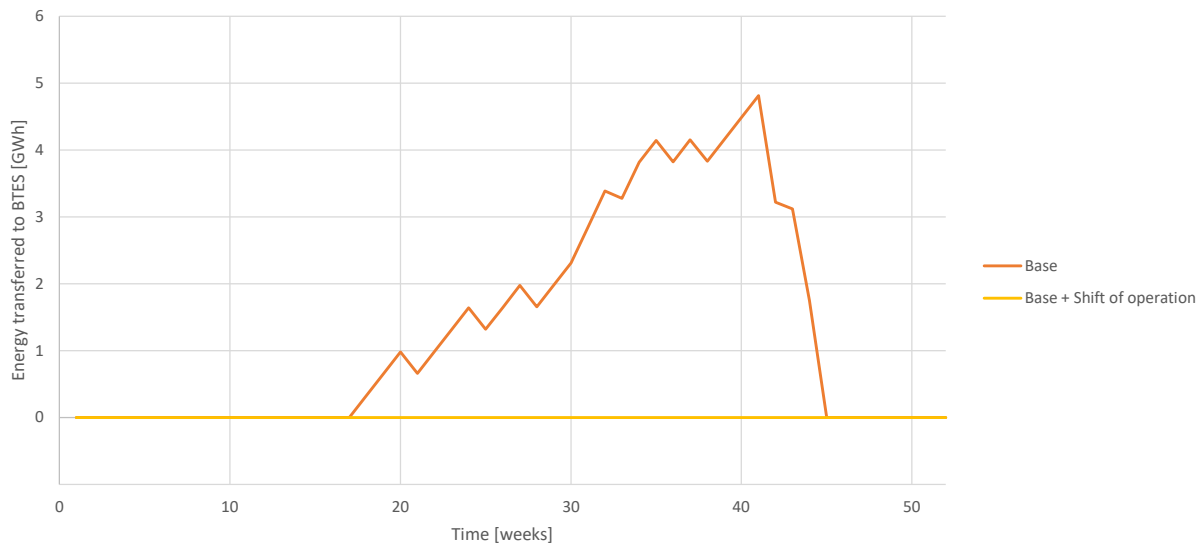

Department of Energy and Process Engineering, NTNU

### Comparison of BTES Capacity and Energy Storage for Base and Optimised WHSS Scenarios at Site G

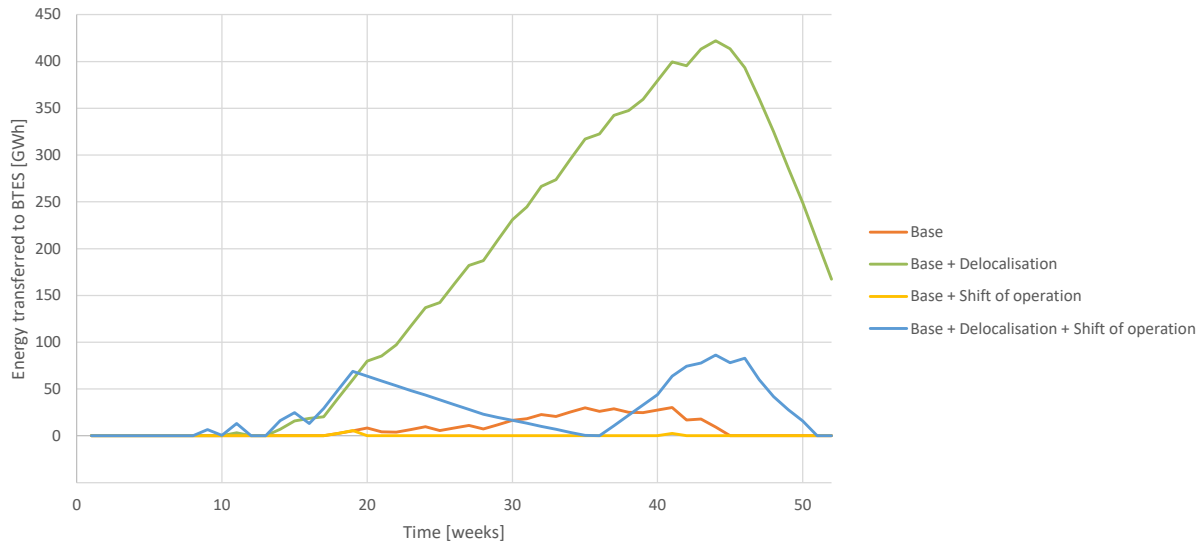

Department of Energy and Process Engineering, NTNU

55

55

### Weekly BTES Energy Transfer and Impact on Cooling Tower Load at Site G

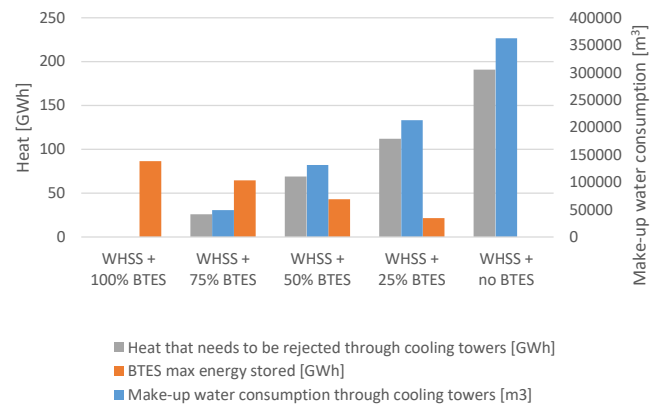
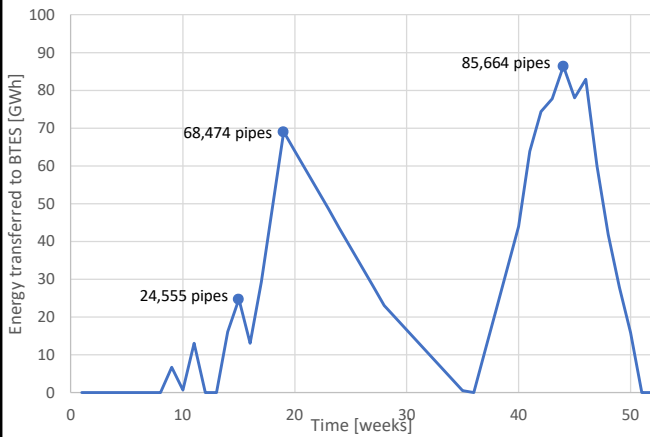

Department of Energy and Process Engineering, NTNU

56

56

### Cooling Tower Water Demand under Varying BTES Coverage at Site G

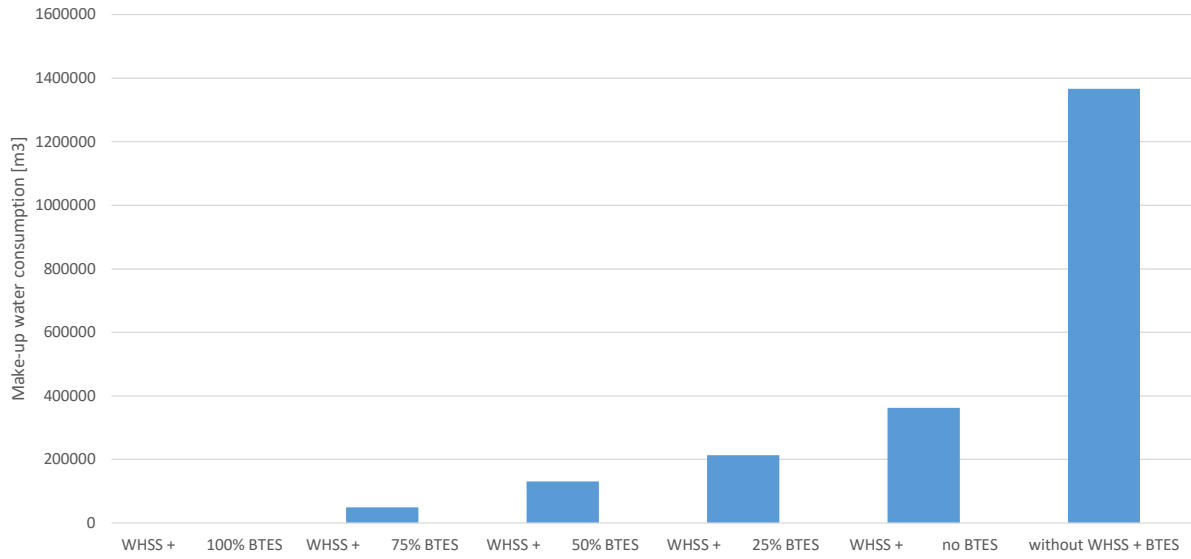

Department of Energy and Process Engineering, NTNU

57

57

### Comparison of BTES Capacity and Energy Storage for Base and Optimised WHSS Scenarios at Site H

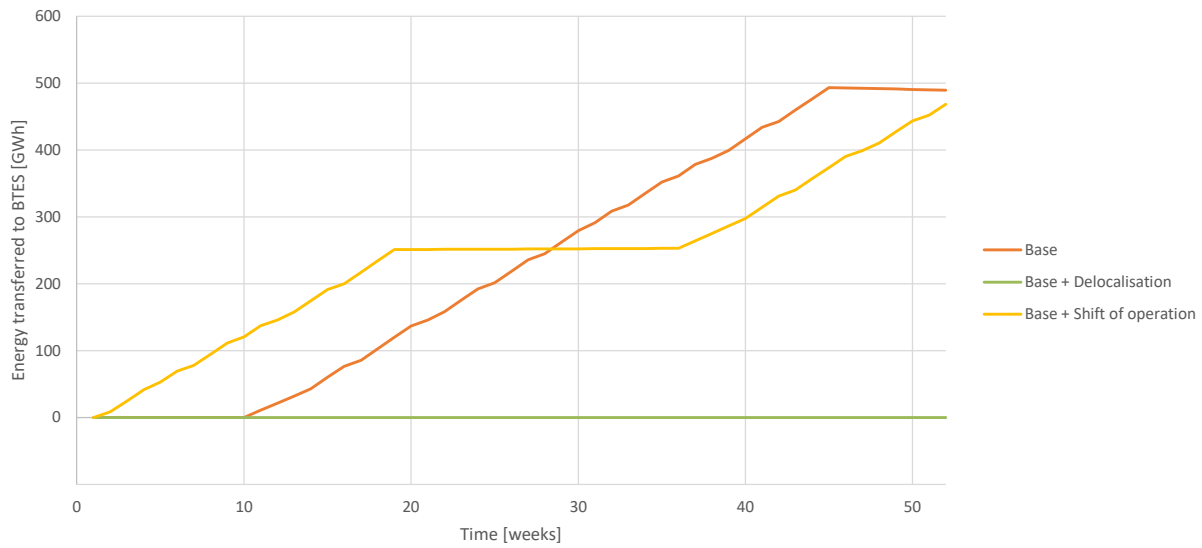

Department of Energy and Process Engineering, NTNU

58

58

### Comparison of BTES Capacity and Energy Storage for Base and Optimised WHSS Scenarios at Site J

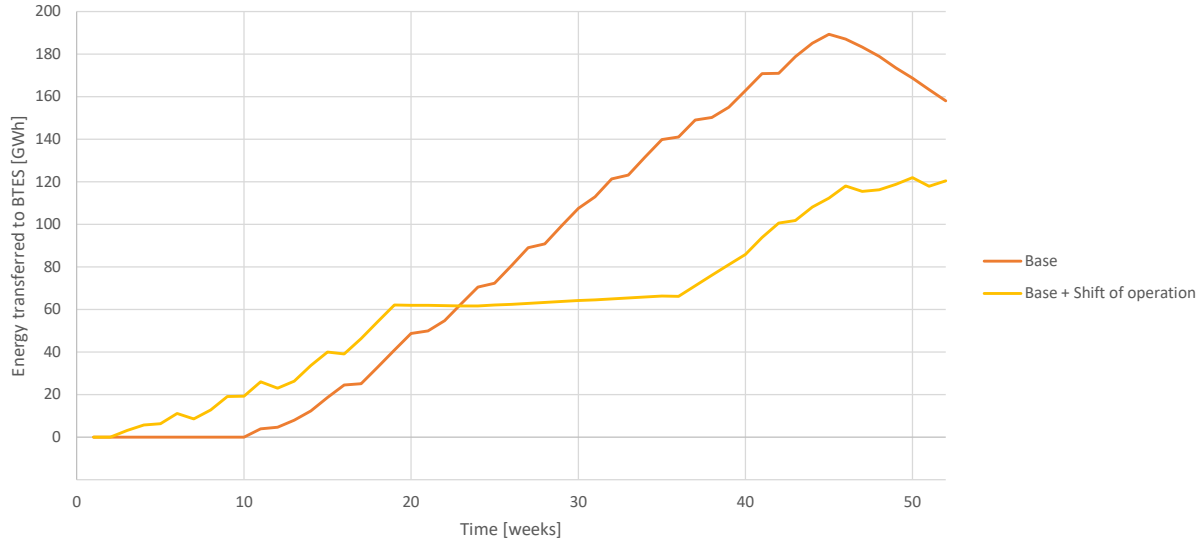

Department of Energy and Process Engineering, NTNU

### Weekly BTES Energy Transfer and Impact on Cooling Tower Load at Site J

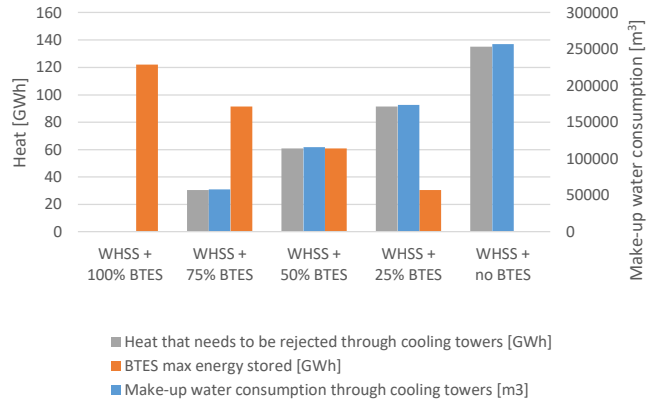
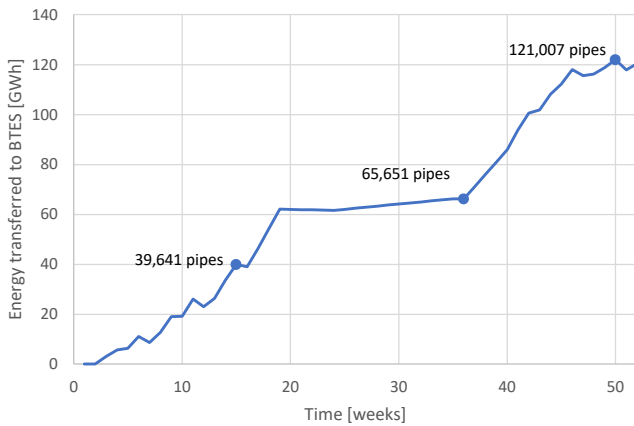

Department of Energy and Process Engineering, NTNU

