

MAGNET'S CIRCUITS AND SYSTEM OPTIMISATION UPDATE

B. Wicki, S. Pittet, D. Aguglia, M. Colmenero Moratalla

CERN

Accelerator Systems (SY Dept.), Electrical Power Converter (EPC Group)

Many thanks to:

J. Bauche, C. Jaermyr Erikson, L. Von Freeden and H. Deveci, TE-MS
M. Parodi and C. Marcel, EN-EL
J.-P. Burnet, ATS-DO
S. Valette and B. Bouvet, HSE-ENV

G. Peon and I. Martin Melero, EN-CV
T. Paul Watson and L. Bromiley, SCE-DOD
F. Valchkova-Georgieva, EN-ACE

21 May 2025

Table of Contents

- ❑ Global Model :
 - Submodels
 - Parameters Consideration
 - Price and Constraints Consideration
- ❑ Power Converters Submodel :
 - Top-Down Price Estimation
 - Circuits Optimisation
- ❑ What's new from 2024
- ❑ Global Optimisation Scenarios Results :
 - Minimising TOTEX
 - Minimising CO2 Equivalent Mass
 - Changing OPEX Weighting Factor
- ❑ Conclusion

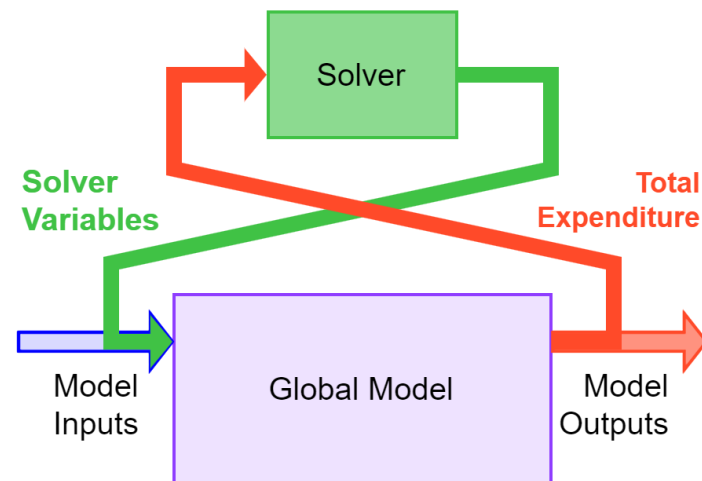

Submodels of Global Model

The global model is composed of multiple interconnected sub-models, each intricately linked. Every sub-model is tailored to represent a distinct segment of the broader system.

The **Total Expenditure** is the **Sum** of the **Capital** and **Operational Expenditure** of each submodels :

- ❑ **Magnets** **TE-MS-NCM** with script modelling MSC's magnets.
- ❑ **Power Converters** **SY-EPC** with existing converters + adjustment to FCC's need.
- ❑ **Cables + Cable-Trays** **EN-EL** with CERN Catalogue.
- ❑ **Alcoves** **SCE-DO** with Mid Term Review's data given by SCE.
- ❑ **Electrical Equipment** **EN-EL** with EN-EL Catalogue.
- ❑ **Cooling and Ventilation** **EN-CV** with Mid Term Review's data given by CV.

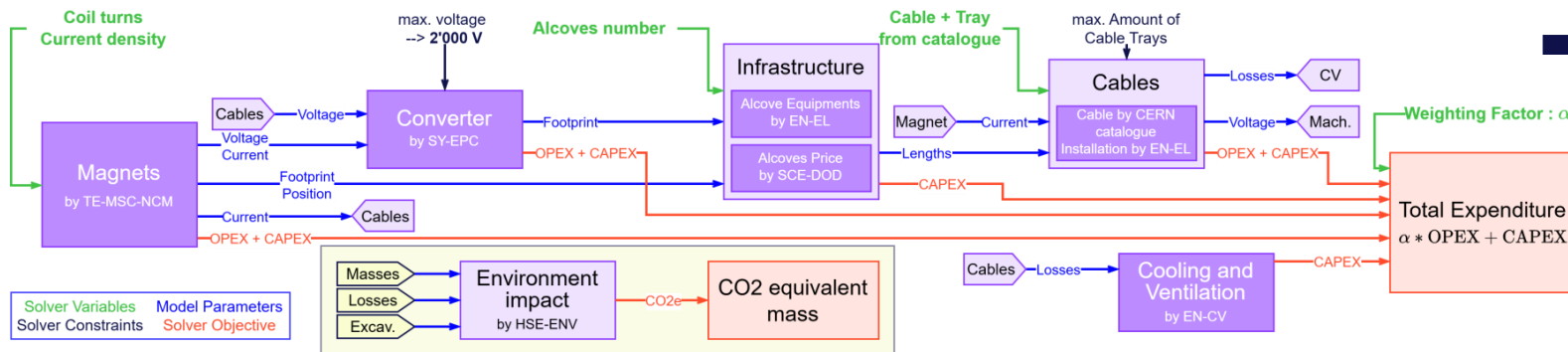

Parameter Consideration of Global Model

Parameters taken into account :

- ❑ **Magnets** : Material quantity, Power losses
- ❑ **Power Converters** : Material quantity, Power losses
- ❑ **Cables + Cable-Trays** : Material quantity, Power losses, Installation
- ❑ **Alcoves** : Volume, Schedule change
- ❑ **Electrical Equipment** : Equipment in alcoves
- ❑ **Cooling and Ventilation** : Equipment upgrade needed to accommodate Cable's power losses
- ❑ **Environment Impact** : Material quantity, Power losses, Alcove excavation (excavation, transport and disposal)



The current submodels were chosen as most representative of **current input parameters**.

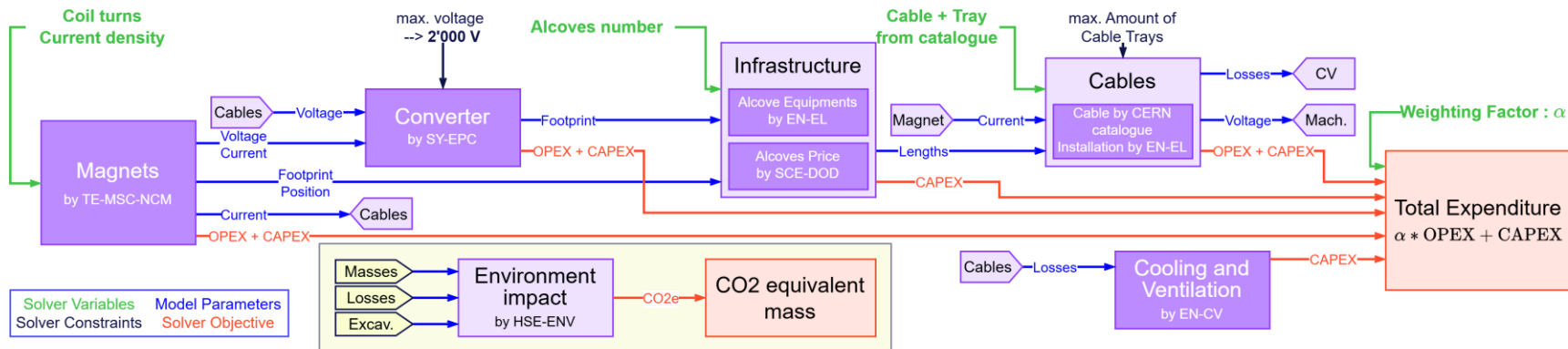

Price Consideration and Constraints of Global Model

Price consideration taken in the global model :

- ❑ **Electricity cost for 15 years of operation**, integrated energy levels considering machine OP cycles.
- ❑ **Booster mean power with top-up filling scheme** as OPEX.
- ❑ Length of cable for each circuit is considered as CAPEX and OPEX.
- ❑ **Alcove volume and schedule change** are considered as CAPEX.
 - **Schedule change has other impacts beyond cost.**

Other parameters accounted for :

- ❑ **Space taken in the cable trays**
- ❑ **Number of alcoves**
- ❑ **Power losses in the air** for cooling limits
- ❑ **Maximum voltage** for cable isolation
- ❑ **Water cooling performance** of magnet

Pricing Model **Not** Accounted for :

- ❑ Uninstallation of equipment
- ❑ OPEX of Cooling and Ventilation
- ❑ Radiation protection
- ❑ ...

Power Converters : Top-Down Price Estimation

We use a top-down approach to estimate the price of the converters for each circuits:

- ❑ We listed all power converters built by the group with their parameters and price.
- ❑ The closest converter to the needed circuits parameters is found.
- ❑ Correction factors are applied the reference price, to suit the circuits need in term of availability, reparability, voltage difference, etc... → The corrected price is calculated.

A more refined approach will be realised in the future.

Reference Converters # → extrapolated from existing converters	Total FCC Quantity	DC			Cycled			Rack Quantity	Mass	Reference Price	CorrectionFactor									Corrected Price
		Voltage	Current	Power	Peak Voltage	Peak Current	Peak Power				Inflation	Redundancy	Reparability	Spares	Power Margin	Unification	Quantity	Voltage	Current	
		[V]	[A]	[kW]	[V]	[A]	[kW]				[-]	[-]	[-]	[-]	[-]	[-]	[-]	[-]	[-]	
Boreal 2P	16	400	3 000	1 000	400	3 000	1 200	19	9 050	208	1.00	1.29	1.50	1.10	1.10	1.00	1.00	1.05	1.22	624
# Saturn 4S	80	1 600	850	1 360	1 600	850	1 360	23	15 000	292	1.15	1.15	1.50	1.10	1.10	1.00	Sextupoles cost a lot			
Polaris S	1 168	281	178	50	360	400	75	3	2 700	51	1.00	1.55	1.50	1.10	1.10	1.00	0.80	1.01	1.00	115
MACAO	1 419	150	13	1				1/10	31	7	1.30	1.00	1.00	1.10	1.00	1.00	0.80	1.00	0.90	7
CUTE2 48	8 472			0				1/21	11	5	1.15	1.00						0.99	1.10	5
Boreal 2S2P	16	Lots of Sextupoles and Correctors		2 000	800	3 000	2 400	35	16 750	349	1.00	1.23	1.00	Correctors converters aren't redundant			1.07	1.02	849	
Sirius 2S	16			32	900	450	405	4	1 500	72	1.02	1.41	1.00					1.23	0.90	208
# Mexico 6	692	400	6	2	400	6	3	1/6	42	10	1.15	1.00	1.00	1.10	1.00	1.00	1.00	1.01	1.60	21
CANCUN 20	6 112	75	20	1				1/6	42	7	1.34	1.00	1.00	1.10	1.00	1.00	0.70	0.95	1.00	7

Power Converters : Circuits Optimisation

Parameters in red -> Unknown or under study (Straight-Section: 15% of Arc)

Circuits GHC	Magnet Quantity	Circuit Quantity	Converter Price distribution	
	[-]	[-]	[%]	
Collider	Dipole	5 680	16	2
	Quadrupole	2 836	32	5
	Sextupole	4 672	1 168	27
	<i>Sub-total</i>	13 188	1 216	34
	Dipole Tapering	5 680	710	2
	Quadrupole Tapering	5 672	709	2
	Horizontal Corrector	2 824	2 824	5
	Vertical Corrector	2 824	2 824	5
	Skew Quadrupole	2 824	2 824	5
	<i>Sub-total</i>	19 824	9 891	19
Straight section (15% of Arc)	4 952	1 666	8	
Collider Total	37 964	12 773	61	
Booster	Dipole	5 536	16	3
	Quadrupole	2 768	32	5
	Sextupole-Focusing	576	16	1
	Sextupole-Defocusing	560	16	3
	<i>Sub-total</i>	9 440	80	11
	Dipole Tapering	2 768	346	3
	Quadrupole Tapering	2 768	346	3
	Horizontal Corrector	1 672	1 672	5
	Vertical Corrector	1 672	1 672	5
	QuadrupoleCorrector	1 384	1 384	4
Skew Quadrupole	1 384	1 384	4	
<i>Sub-total</i>	11 648	6 804	23	
Straight section (15% of Arc)	3 163	1 033	5	
Booster Total	24 251	7 917	39	
Grand Total	62 215	20 690	100	

The collider and booster rely on many sextupole and correctors circuits, each of which cost a substantial amount.

Corrector magnets take 42% of total cost

With redundant converters, the price will increase significantly.

Circuit count vs consumption

Can we reduce the number of circuit or their power consumption ?

Criticality assessment

How many circuit can fail before we lose the beam ?

Targeted redundancy

By applying redundancy at the system level where possible and having redundant converters when needed, we can reduce considerably the overall cost.

What's new from 2024

More space on cable trays

→ Space constraint has lower impact on the price

Fixed Top-up mode on the booster cycle.

Modelling of the CO₂ equivalent mass.

Collider and booster magnet parameters tweaked and fixed with the magnet team.

Started development of python-based models and solver.

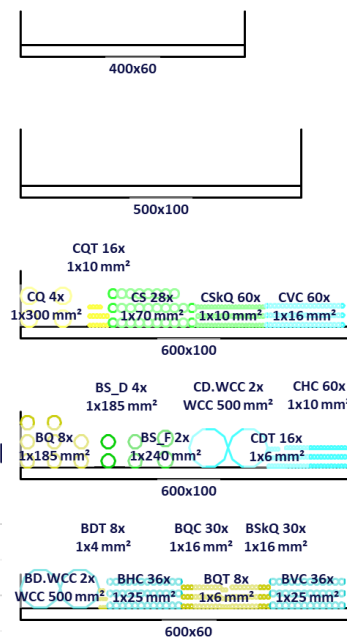
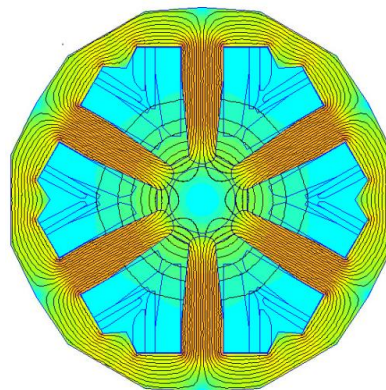
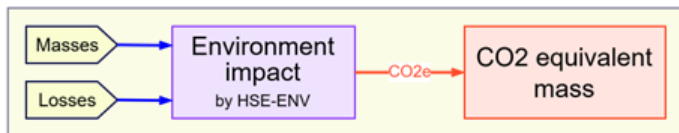

Normalised Energy Level for a Booster Cycle
ttbar Mode in Top-up

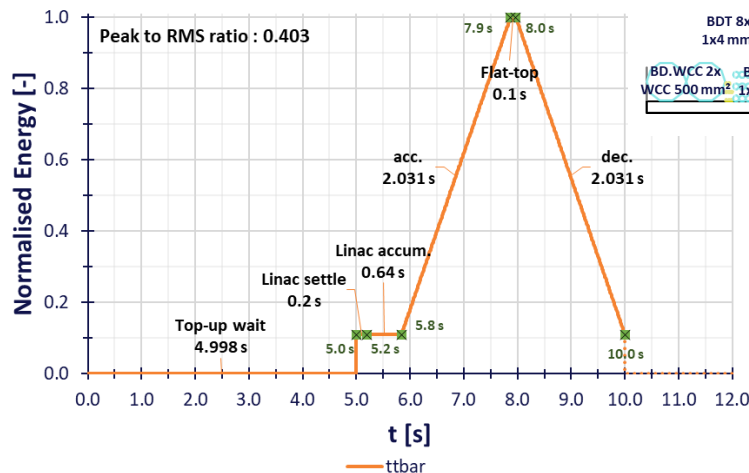

Global Optimisation Scenarios Results

Following slides present optimised solutions, with varying constraints.

The objective being: reaching an **Optimum Total Expenditure** while complying with constraints.

But what is an optimum expenditure ? lowest TOTEX ? lowest OPEX ? lowest CAPEX ?

By minimising the expenditures, minimising the CO2 equivalent mass or by adjusting the OPEX weighting factor, we can achieve different optimum suiting to the needs of the project.

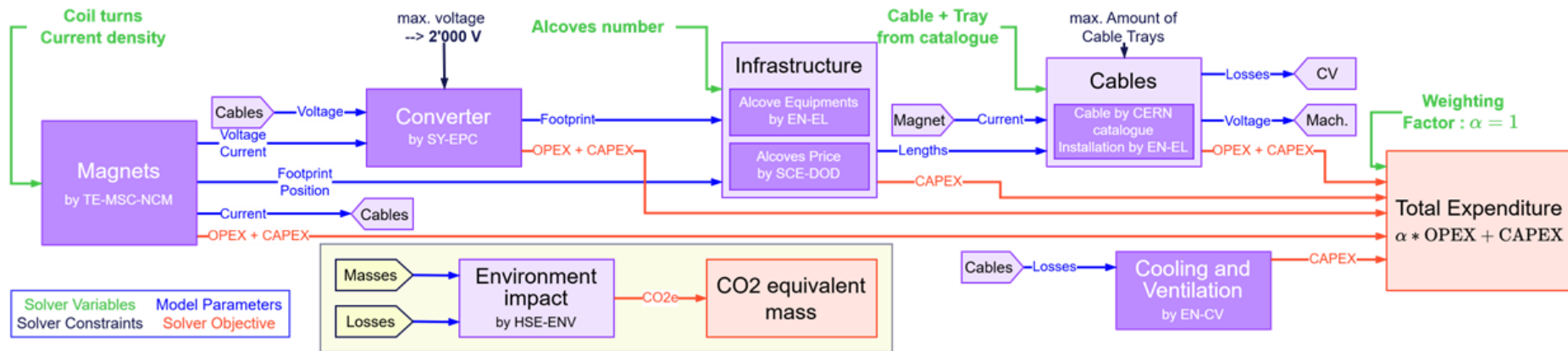

Varying Number of Alcoves by Minimising TOTEX

Expenditures with increased Number of Alcoves by minimising TOTEX

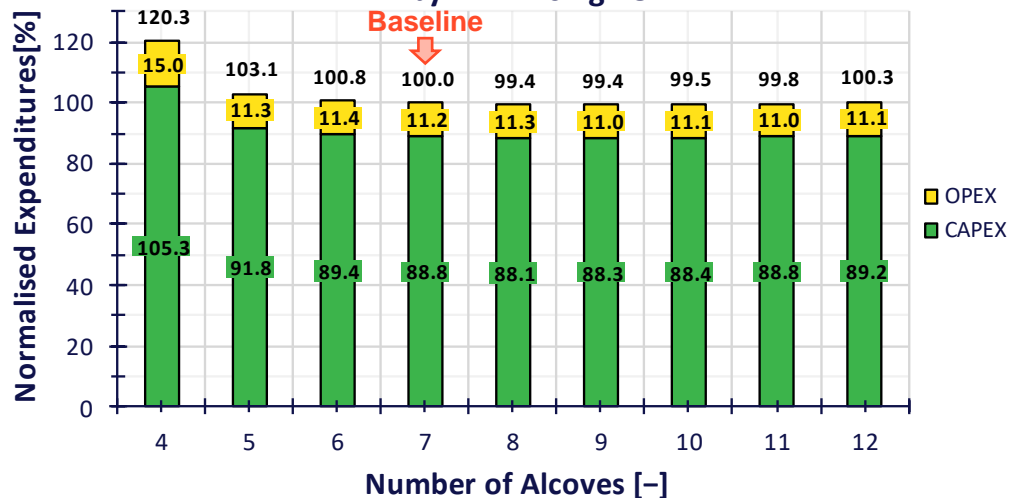

$$TOTEX = \alpha * OPEX + CAPEX, \alpha = 1$$

Other Parameters by minimising TOTEX

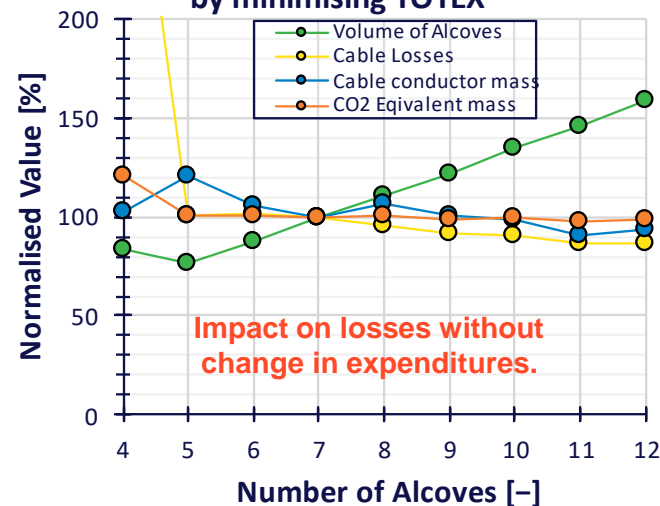

With more space in the cable trays, the space constraint is relaxed.

And as such the total expenditure doesn't move as much with the increase in number of alcoves.

But we can still see an impact on the cable losses in the arc, with more alcoves.

Beyond the capital expenditure, the number of alcoves has a non-negligible impact on the schedule.

Minimising CO2 Equivalent Mass With 7 Alcoves

Instead of minimising the total expenditure, we can optimise the CO2 Equivalent mass and still plot the total expenditure normalised to the baseline values at 7 alcoves when optimising TOTEX.

We can see that with **10%** increase in expenditure, we reduce by **10%** the CO2e mass and by **30%** the cable losses in the arc.

CO2e of alcoves excavation is included

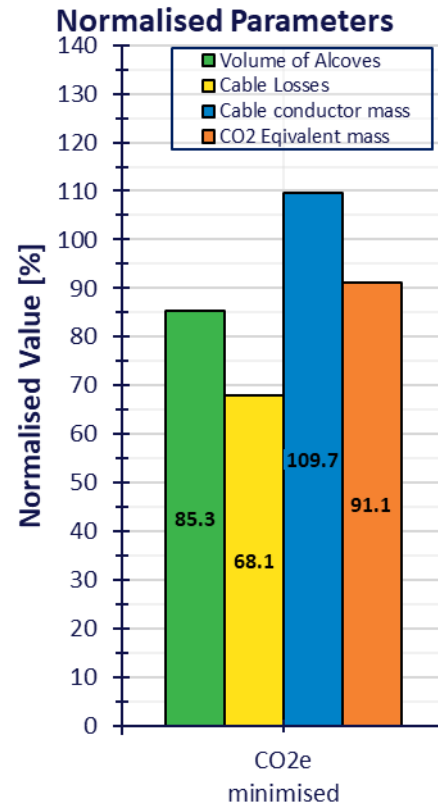
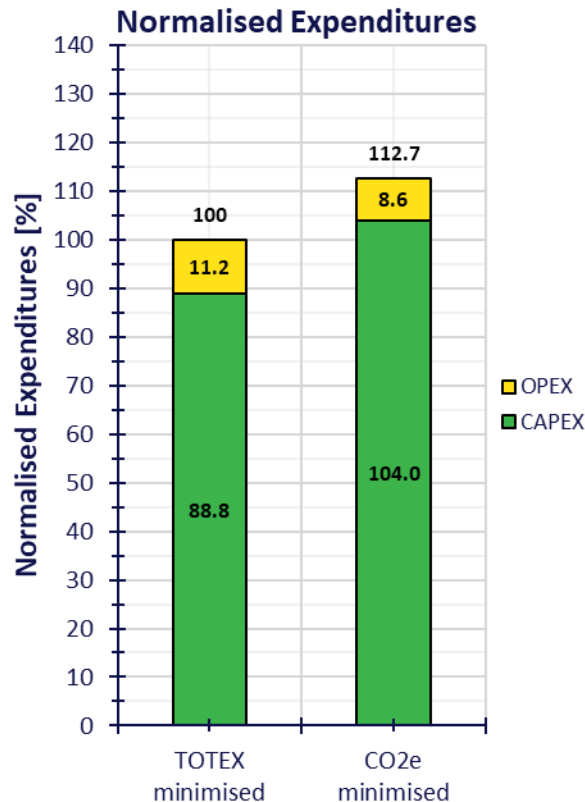

Minimising CO₂e - Varying Number of Alcoves

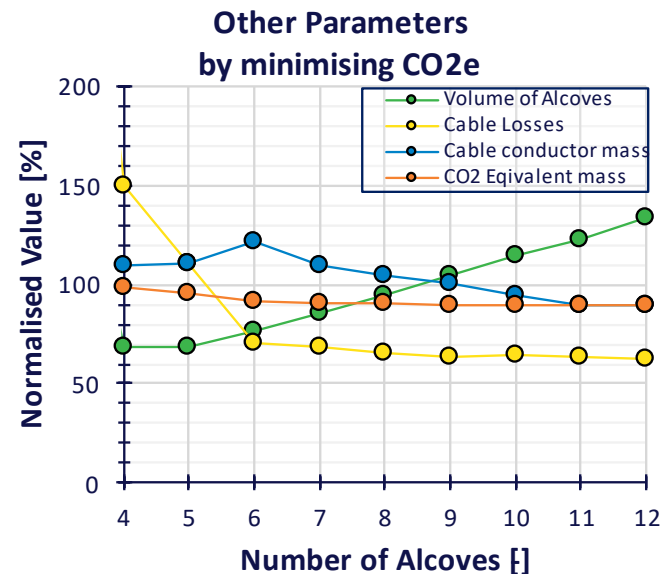
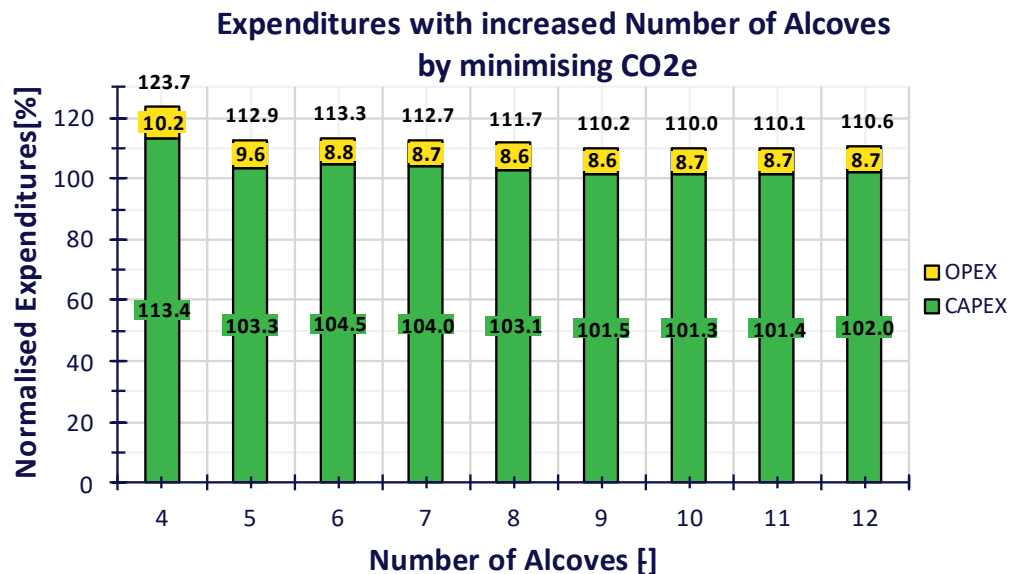

Results when varying the number of alcoves while minimising the CO₂ equivalent mass, normalised to the 7 alcoves baseline with TOTEX minimisation.

Overall, to reduce by 10% the CO₂e we need to pay 10% more.

Changing OPEX Weighting Factor with 7 Alcoves

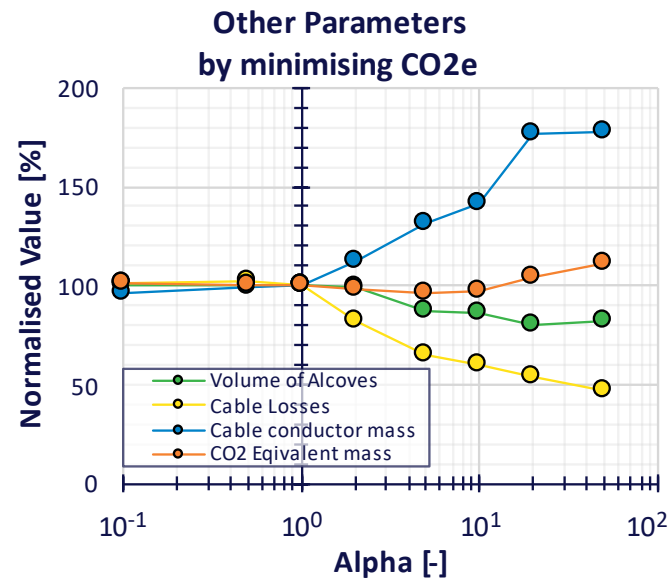
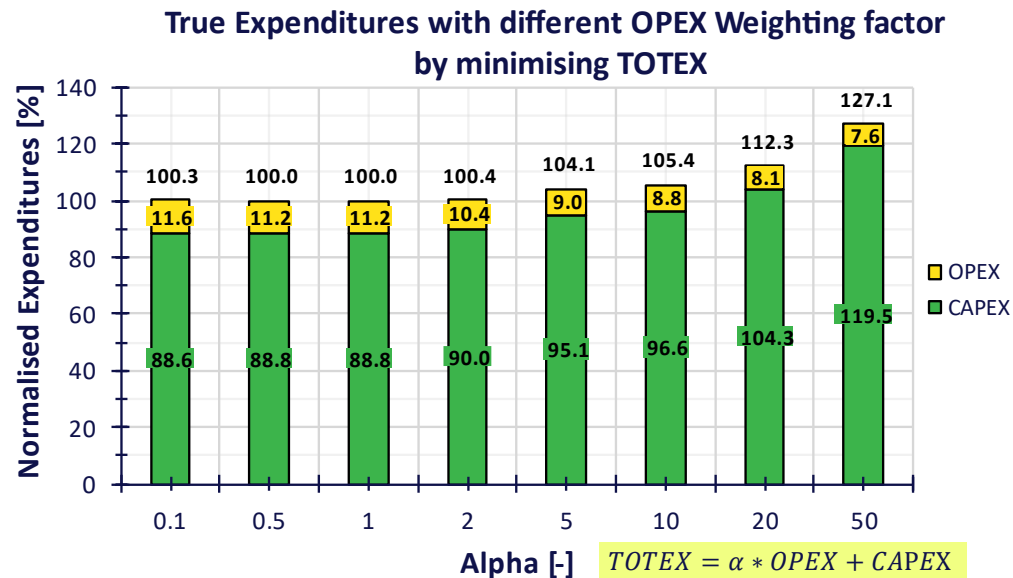

The OPEX weighting factor is also a tool to steer decision; by artificially inflating the OPEX, it increase its importance during the optimisation.

We plot the true expenditure (without the impact of the weighting factor)

With a factor of 2 the TOTEX doesn't change, but we see a lower power losses of **20%** in the cables.

Conclusion

The Global Optimisation tool let us experiment scenarios and qualify the impact on the Total Expenditure and as such the sensibility of choices.

The ratio of OPEX vs CAPEX is a choice that needs to be taken by management. Either having a lower investment cost and higher running cost or a higher investment at the start for lower power consumption in operation.

With this tool, an environmentally friendlier FCC can be achieved

- ❑ by prioritising the operation expenditure with the OPEX weighting factor
- ❑ or by minimising the CO2 equivalent mass instead of the total expenditure.

What we need :

- ❑ Booster and Collider circuit definition
 - Complete lattice including arcs + straight sections
 - Criticality of the circuit, redundancy level
 - Serial connection or single powering of magnet

What's the future :

- ❑ More refined cost estimate of the converters
- ❑ GHC vs LCC optics comparisons
- ❑ Continue exchange with other groups to integrate and refine their models.





ANNEXE

21 May 2025

Small and Big Alcoves in the Arcs

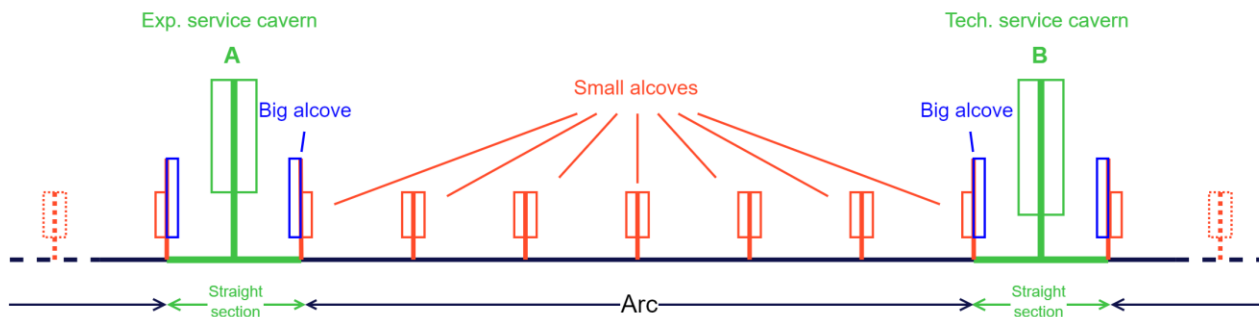

Magnet powering path from the alcoves :

+ Small Alcoves :

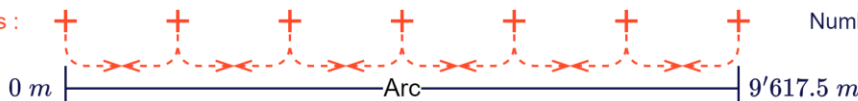

Number of alcoves : 2 + 5

Number of circuits : 12

X Big Alcoves :



Number of circuits : 2

Each alcoves power both side
Both ends of an arc houses a bigger alcove.
The big alcoves power the half of the arc.
The small alcoves power a section of the arc

Magnets powering emplacement		Big Alcoves	Small Alcoves
Collider	Dipoles	X	
	Quadrupoles	X	
	Sextupoles		+
	Dipole Tapering		+
	Quadrupole Tapering		+
	Horizontal Correctors		+
	Vertical Correctors		+
	Skew Quadrupoles		+
	Straight Section	X	
Booster	Dipoles	X	
	Quadrupoles	X	
	Sextupoles	X	
	Dipole Tapering		+
	Quadrupole Tapering		+
	Horizontal Correctors		+
	Vertical Correctors		+
	Quadrupole Correctors		+
	Skew Quadrupole		+
Straight Section	X		

Increasing Number of Alcoves by Minimising TOTEX

With more space in the cable trays, the space constraint is relaxed.

And as such the total expenditure doesn't move as much with the increase in number of alcoves.

But we can still see an impact on the cable losses in the arc, with more alcoves.

Beyond the capital expenditure, the number of alcoves has a non-negligible impact on the schedule.

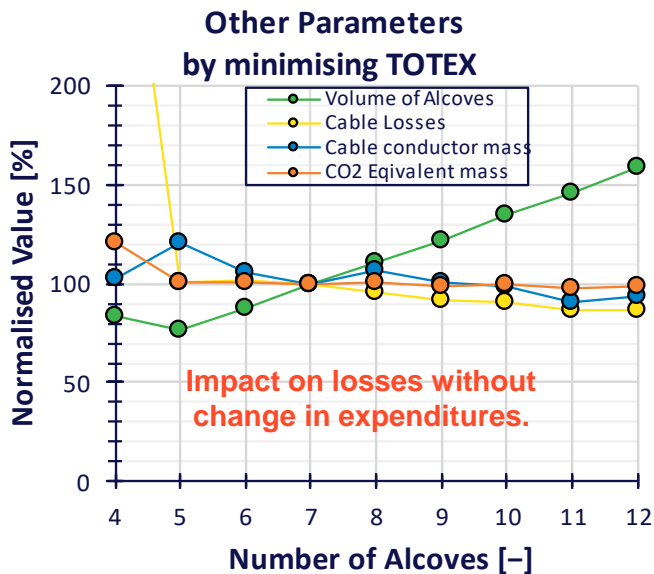
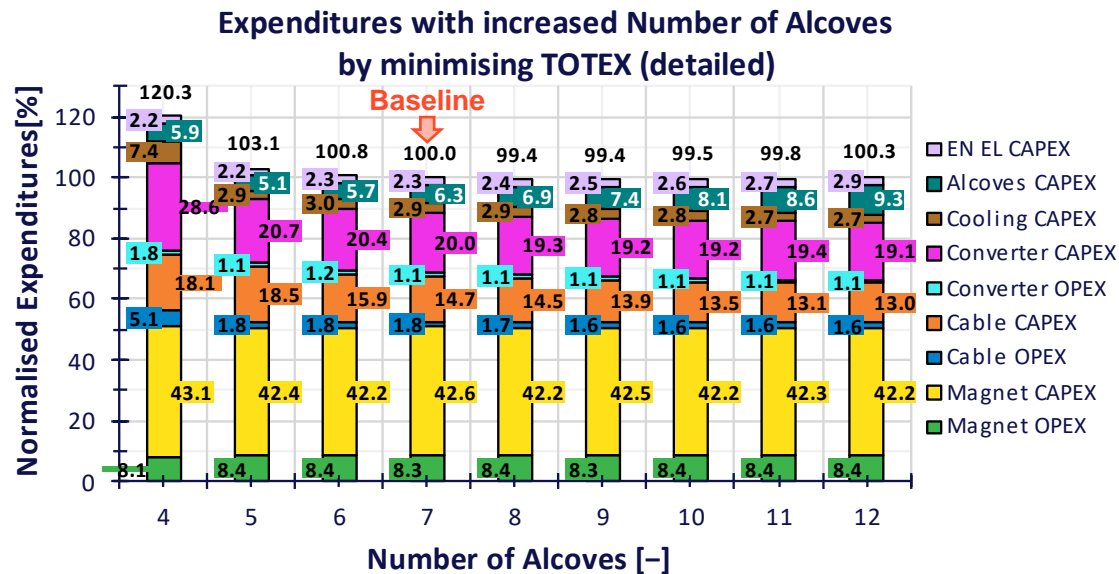

Minimising CO2 Equivalent Mass

Instead of minimising the total expenditure, we can optimise the CO2 Equivalent mass and still plot the total expenditure normalised to the baseline values at 7 alcoves when optimising TOTEX.

We can see that with **10%** increase in expenditure, we reduce by **10%** the CO2e mass and by **32%** the cable losses in the arc.

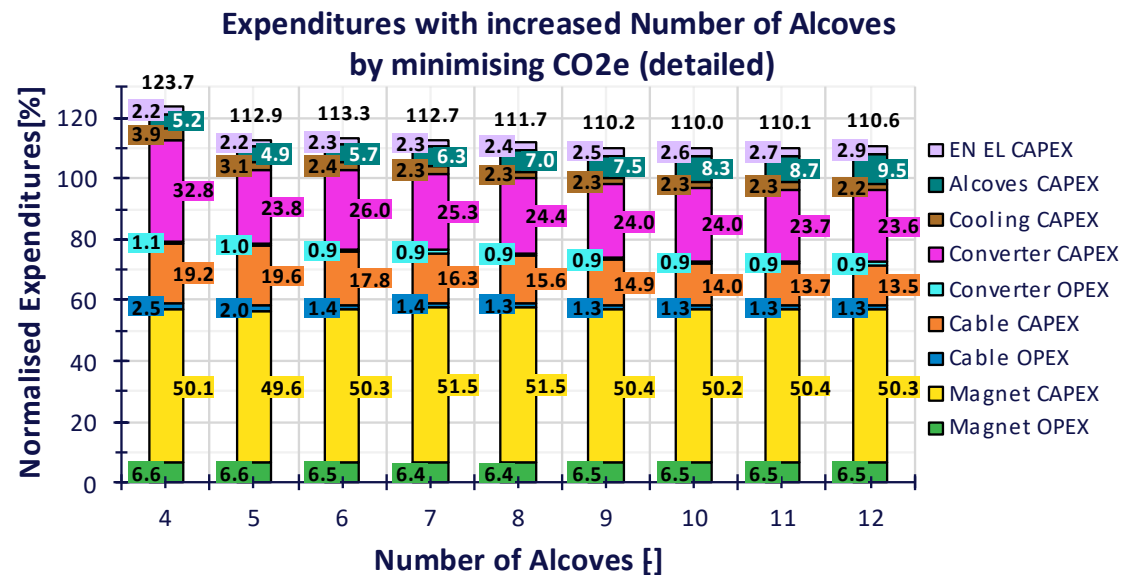

CO2e of alcoves excavation is included

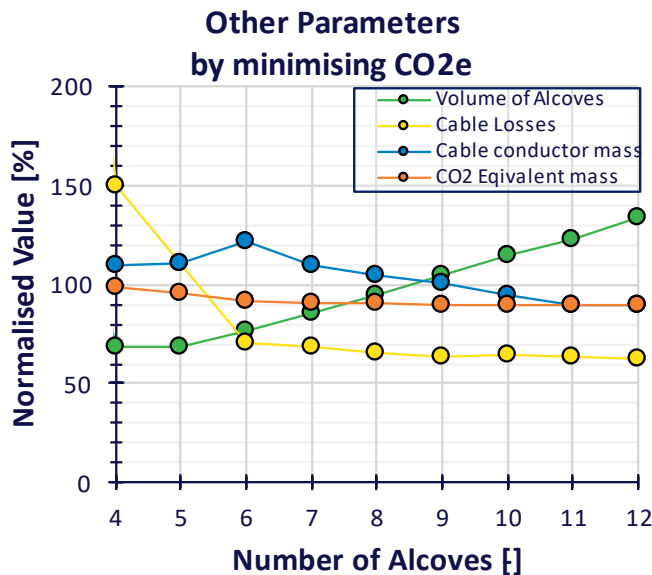

Changing OPEX Weighting Factor with 7 Alcoves

The OPEX weighting factor is also a tool to steer decision; by artificially inflating the OPEX, it increase its importance during the optimisation.

We plot the true expenditure (without the impact of the weighting factor)

With a factor of 2 the TOTEX doesn't change, but we see a lower power losses of **20%** in the cables.

