

EFFECTS AND CRITICALITY OF POWERING FAILURES IN THE FCC-EE MAIN DIPOLE CIRCUITS

Delphine Domange, TE-MPE, CERN

Outline:

- Introduction
- Magnet powering and power converter failure cases
- Simulations and results
- Critically, mitigations and interlocking
- Model improvements
- Conclusions

Failure and machine protection in FCC-ee

FCC-ee collider main parameters		FCC-ee				LHC	LEP II
		Z	W	Zh	$t\bar{t}$		
Circumference (km)		90.65				26.66	26.66
Revolution period (μs)		300				88.9	88.9
Energy (GeV)		45.6	80	120	182.5	7000	96
# bunches		11200	1780	380	56	2808	4
Bunch population (10^{11})		2.14	1.45	1.32	1.64	1.15	4.86
Stored energy (MJ)		17.5	3.4	0.96	0.27	362	0.003
Beam emittance	ϵ_x (nm)	0.70	2.16	0.66	1.51	0.503	34.5
	ϵ_y (pm)	1.05	1.20	0.57	0.82	503	170
Beam energy density ($\beta = 100m$) (MJ/mm²)		4600	470	380	60	$\sim 10^4$	
Energy loss / turn (GeV)		0.039	0.374	1.88	10.29	7×10^{-6}	2.45

Large stored beam energy



Very small beam emittances



Very high energy density and high damage potential in case of fast failure

FCC-ee lattice

V24.3 GHC lattice

- 8 arcs
- 4 experimental insertions
- 4 technical insertions

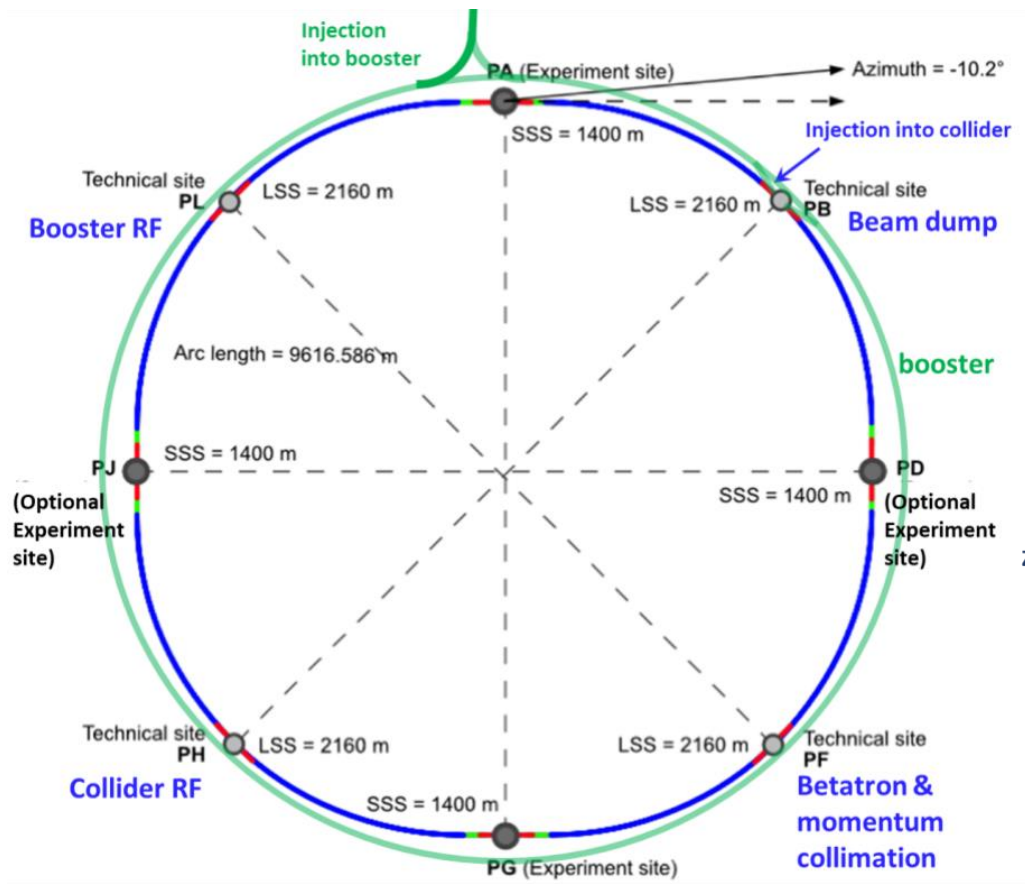

Arc half-cell

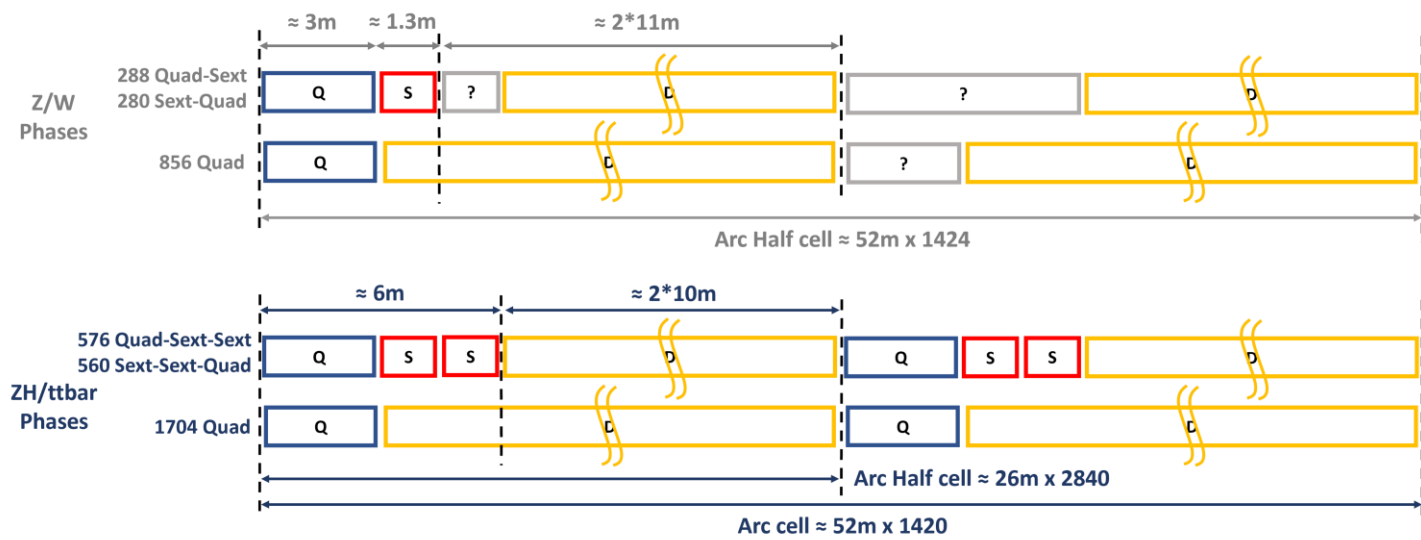

Powering circuits span over long distance and very larger number of main magnets

Layout and magnet powering

Arc dipoles

- Twin aperture
- 2840 magnets (2 half-units)
- Powering by half-arc
- **16 circuits** in total

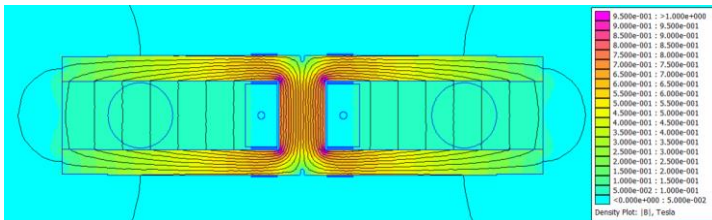

Arc quadrupoles

- Twin aperture
- 2836 magnets
- Powering by half-arc
- **32 circuits** (16 FQ + 16 DQ)

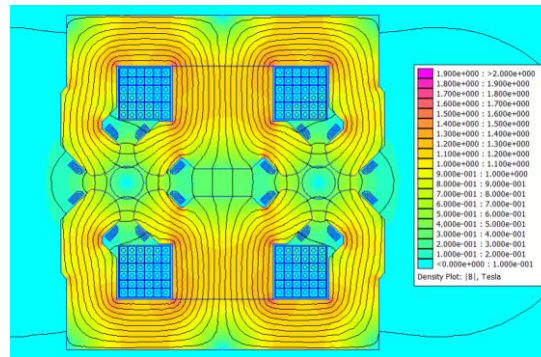

Arc sextupoles

- Single aperture
- 568 magnets at Z
- 2272 magnets at $\bar{t}\bar{t}$
- Powering by families
- **584 circuits** (292 FS + 292 DS)

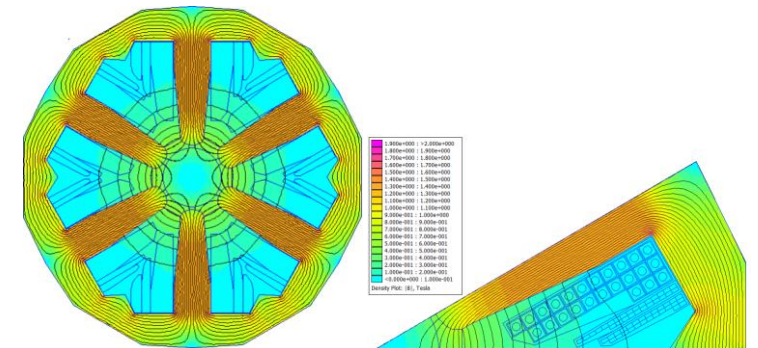

(Half)-Arc dipole circuit powering failures

⇒ Fast decay of the bending field in 1/16th of the machine

$$k_0 \rightarrow k_0 * e^{-t/\tau} \text{ with } \tau = \frac{L_{circuit}}{R_{circuit}} = 0.3 \text{ s}$$

$$L_{circuit} = L_{dip} = 0.184 \text{ mH}$$

$$R_{circuit} = R_{dip} = 0.62 \text{ m}\Omega$$

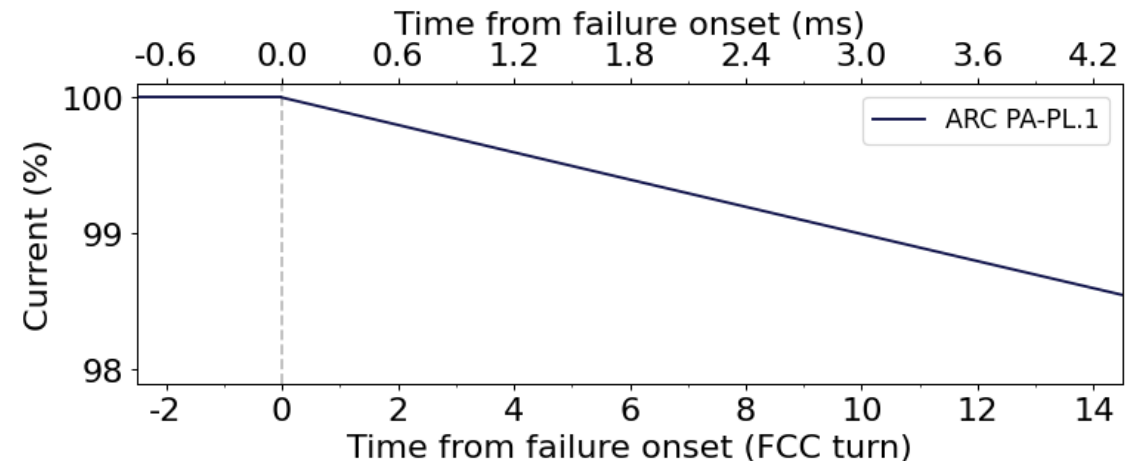
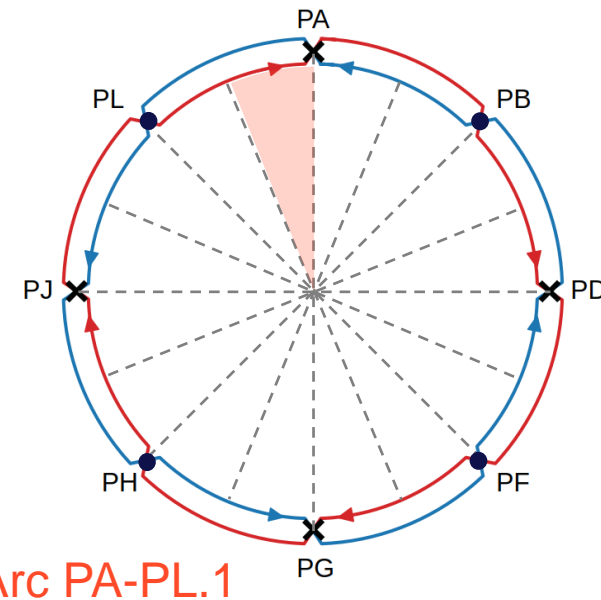

~ 10 turns to lose 1% of the bending magnetic field

Xsuite tracking simulations

Fast dipolar failure simulated using time-dependent fields for all the dipoles in series in the "failing half-arc"

- ✓ Z-pole energy: most critical in terms of energy density
- ✓ Physical aperture: conservative approach, the winglets are not considered
- Collimation is not yet included
- ✓ Synchrotron radiation effects are included

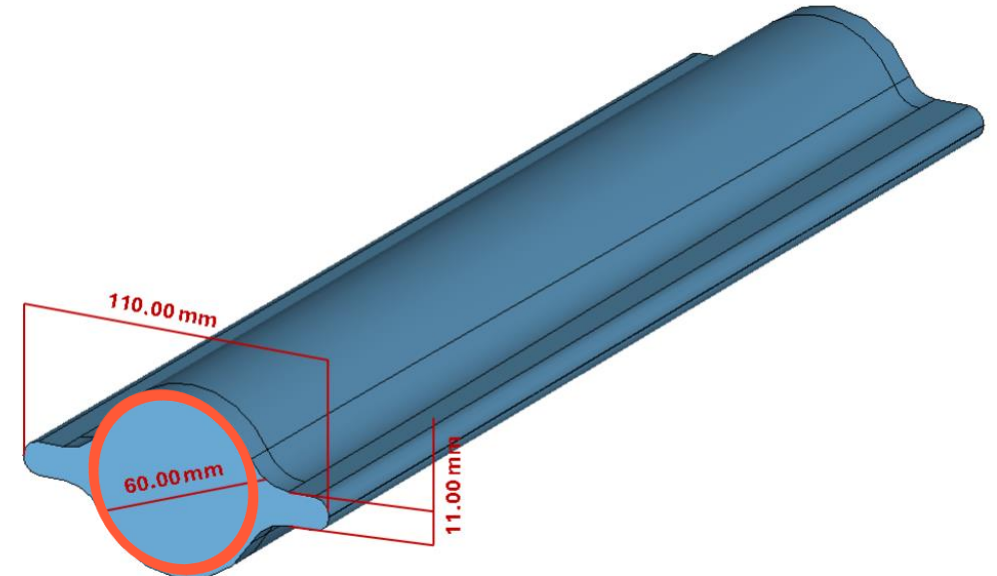
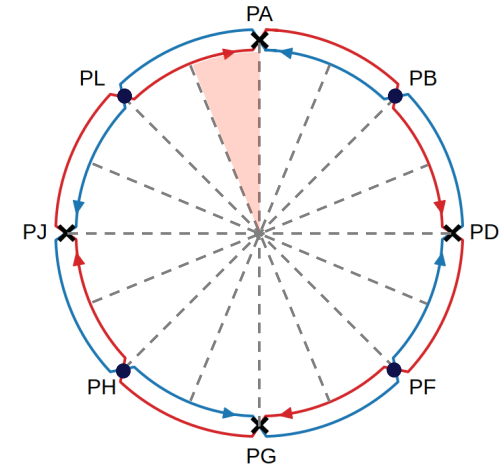

Synchrotron radiation effects

- SR damping \Rightarrow 6D Gaussian bunches matched on equilibrium emittances
 - The damping time constant turns out to be much longer than the failure time-scale
- Horizontal closed orbit has a sawtooth shape due to SR
 - The magnet tapering model does not impact the failure dynamic
 - \Rightarrow Ideal tapering is applied by adapting individual magnet strengths

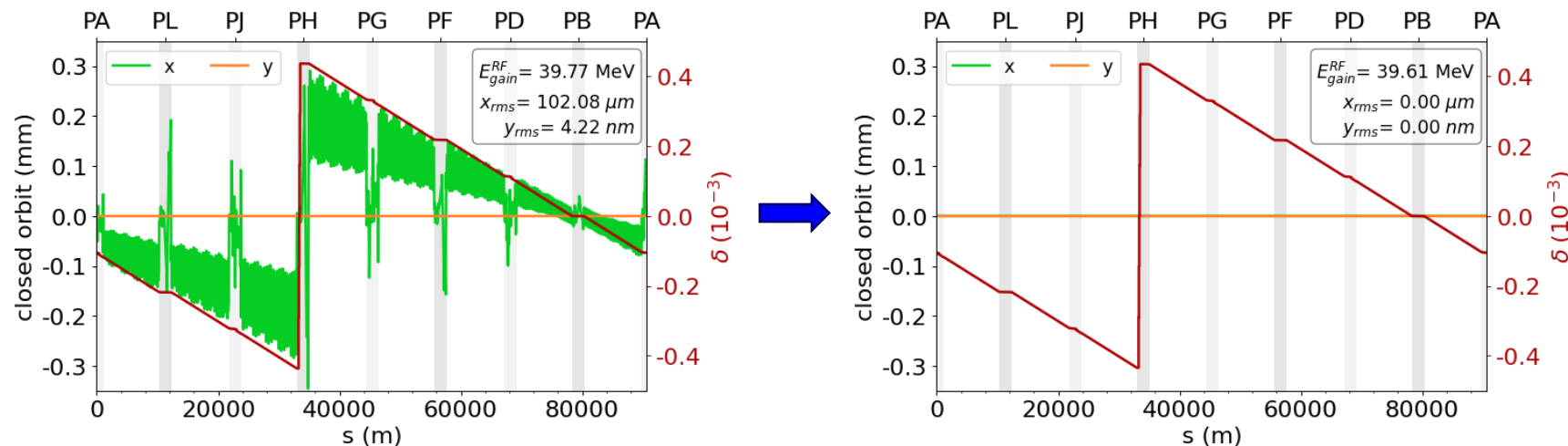

Half-arc PA-PL.1 failing

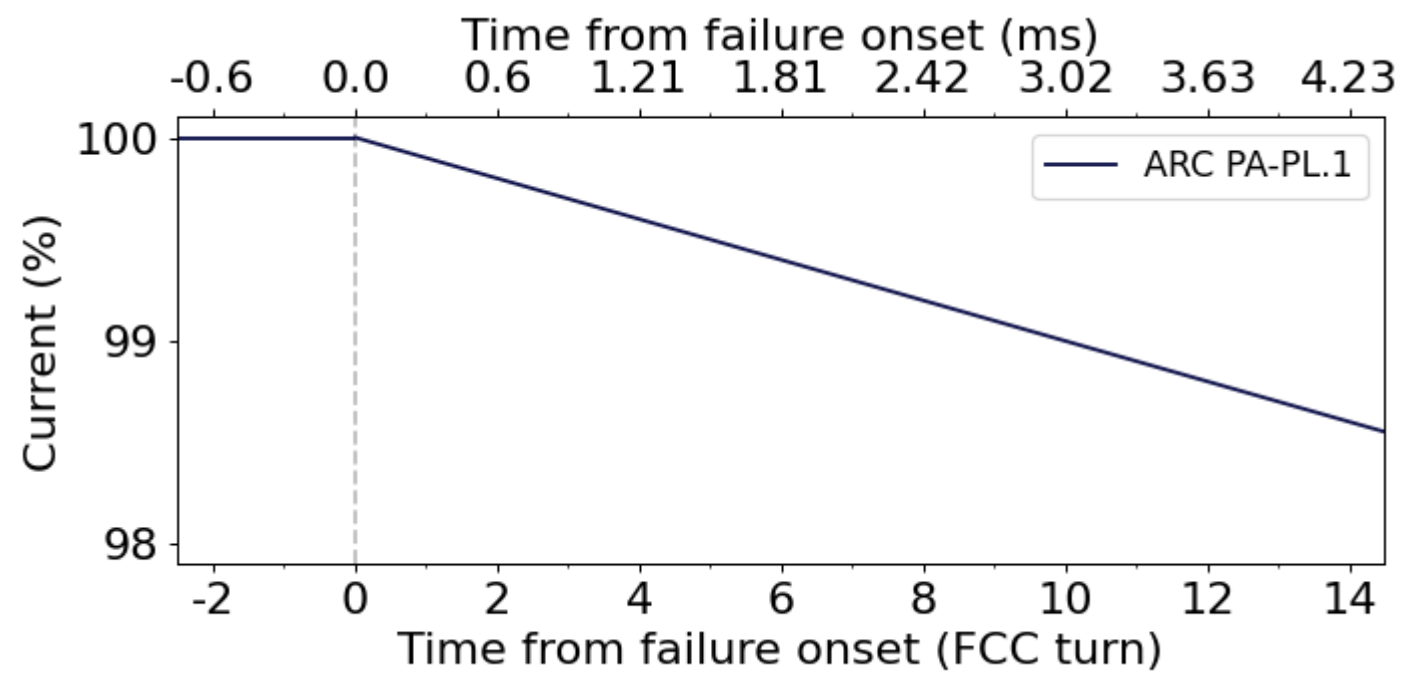
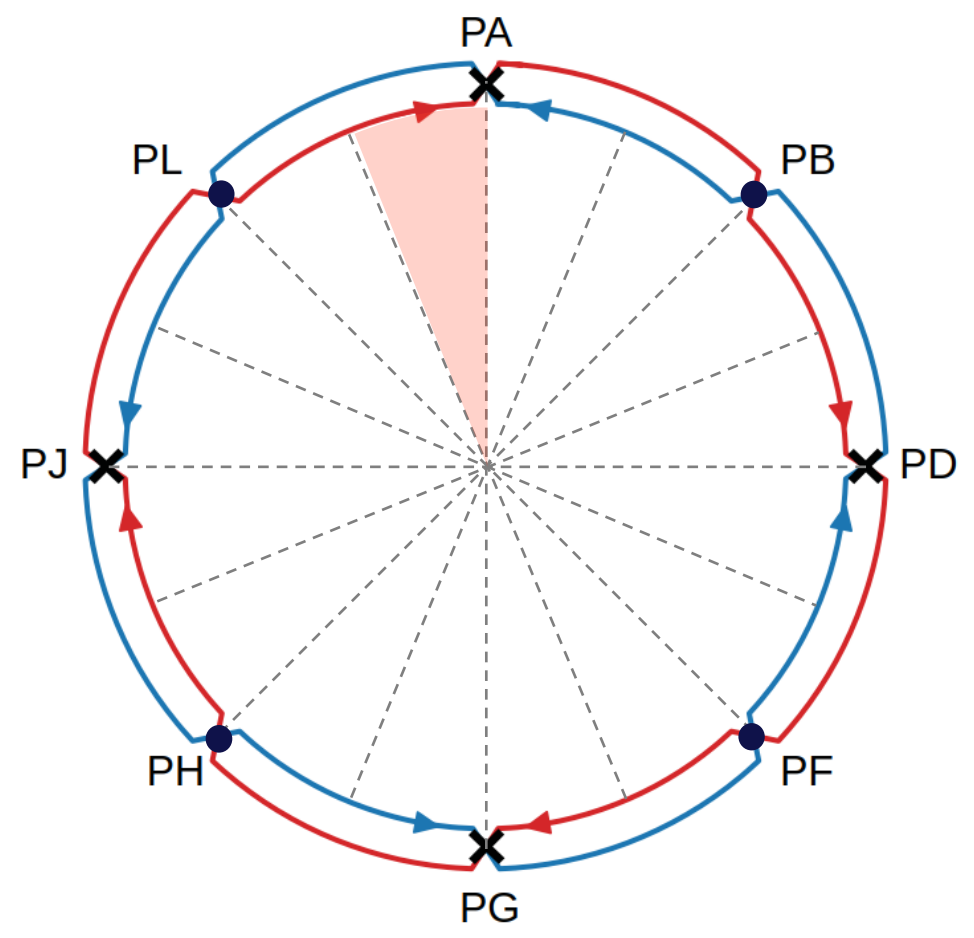

Bunch tracking across FCC-ee

Orbit excursion due to power converter failure

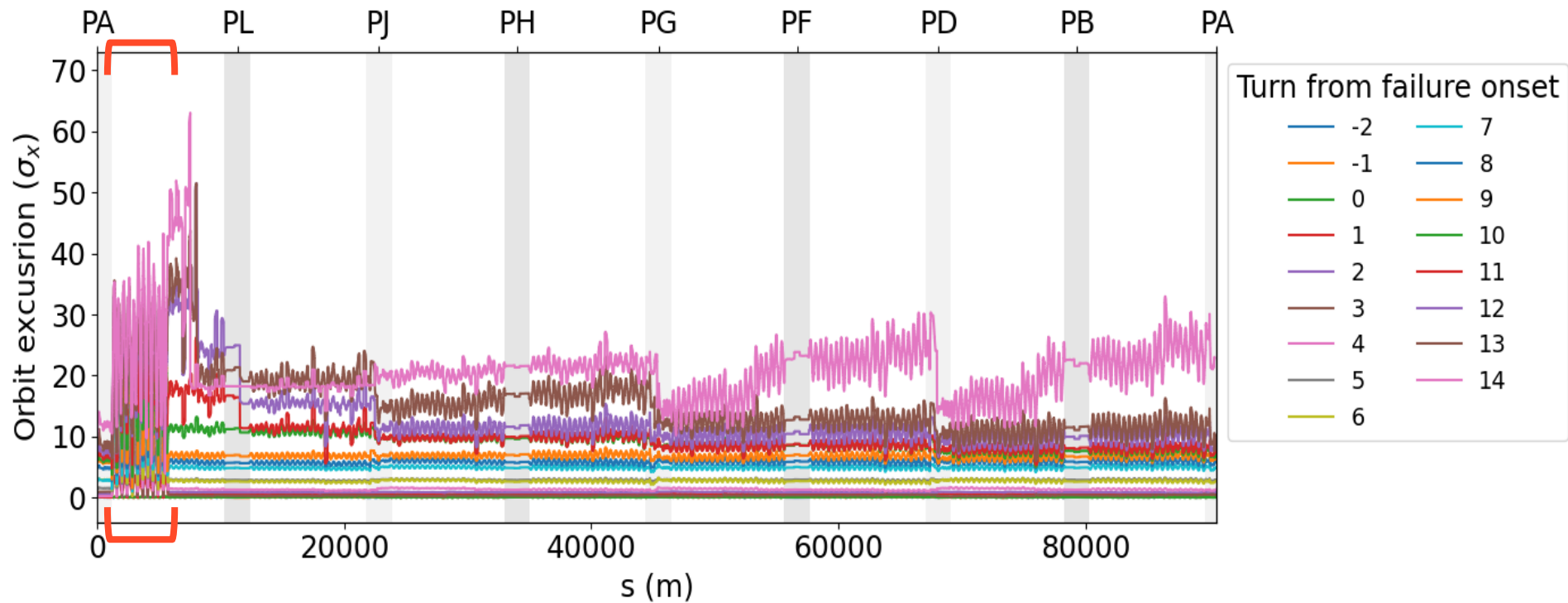
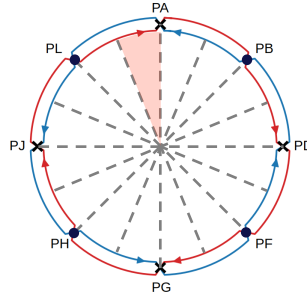

Bunch centroid horizontal amplitude: $\sigma_{orb} = \sqrt{\bar{x}^2 + \bar{p}_x^2}$

Large oscillation in the failing half-arc

Amplitude oscillation in failing half-arc

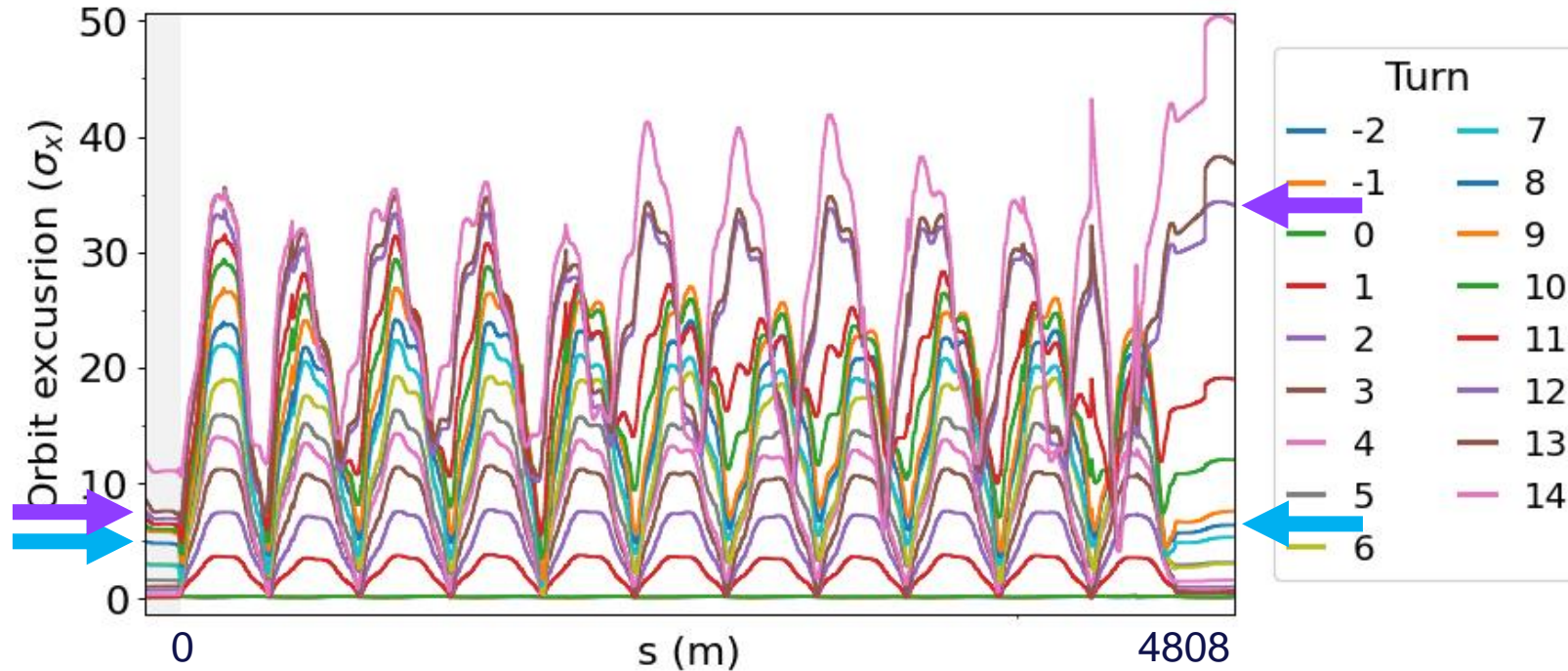
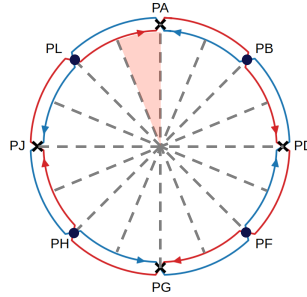

Phase advance modification due to offset in the strong sextupoles

- Favorable phase advance \Rightarrow closed bump and limited orbit excursion (turn 8)
- Unfavorable phase advance \Rightarrow opened bump, oscillation leakage and large orbit excursion (turn 12)

Orbit oscillation along the collider

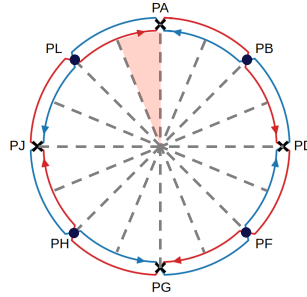
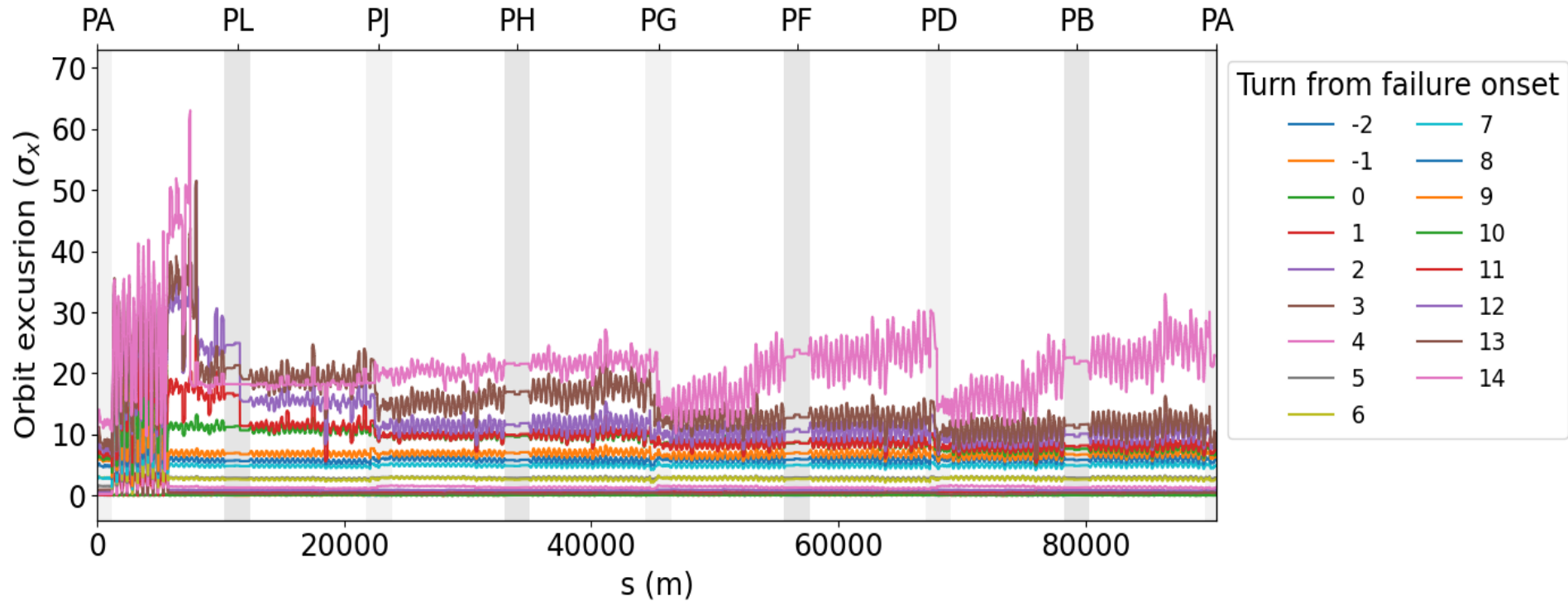

The large orbit excursion induced by the oscillations leakage leads to offset in the quadrupoles and sextupoles outside of the failing region introducing additional orbit distortions

Turn-by-turn orbit excursion

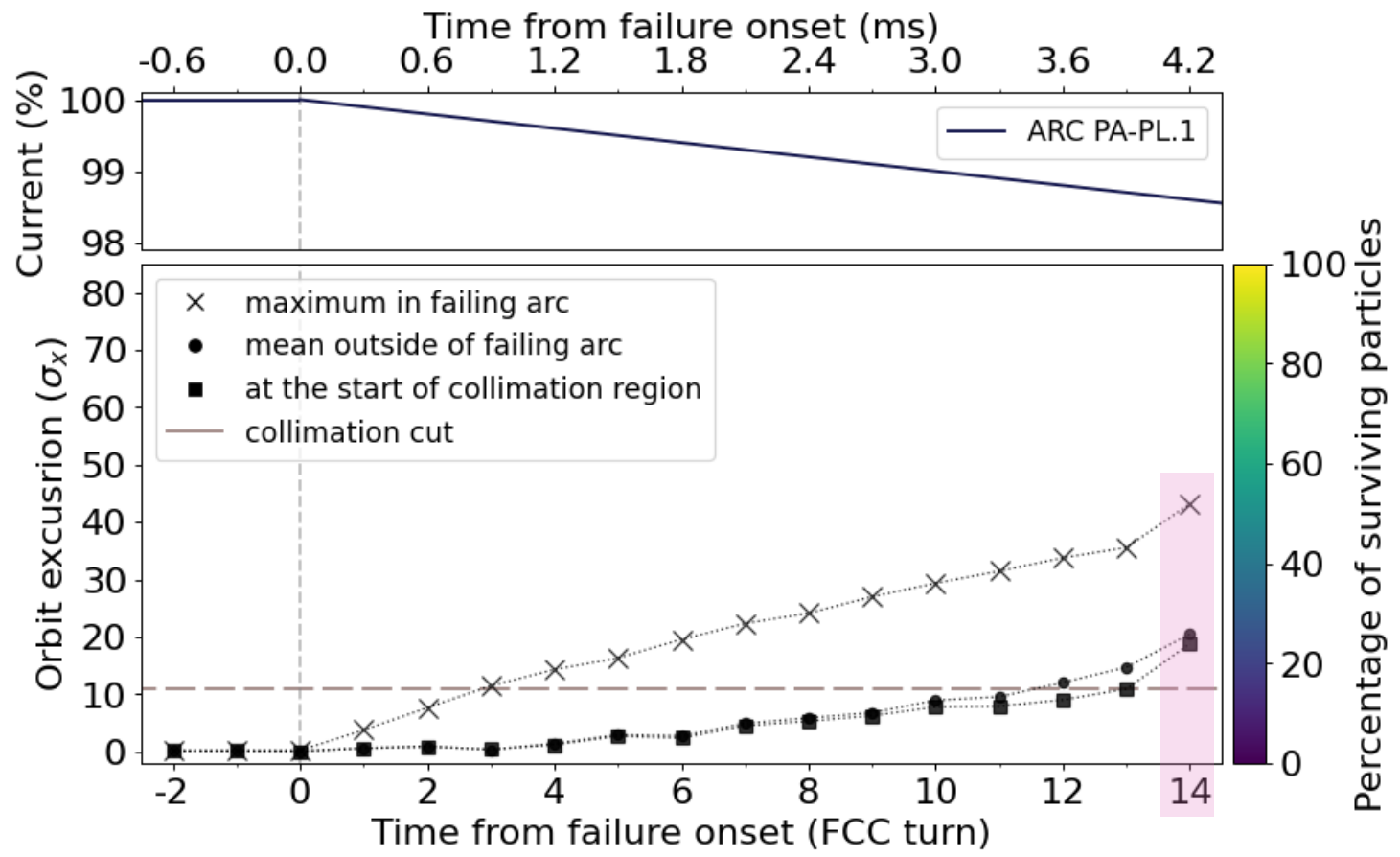
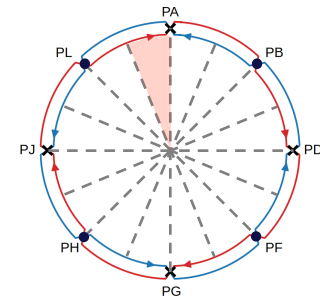

- Focus on the orbit excursion at two points of the machine

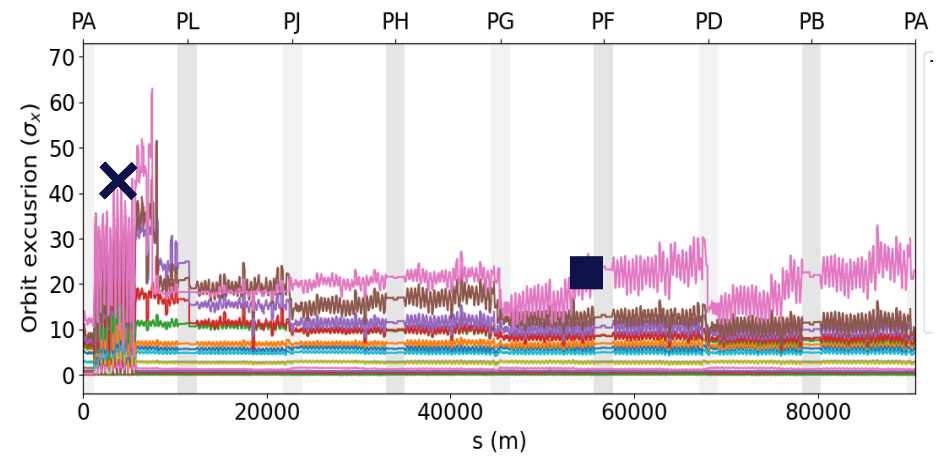

- Tracking until all particles are lost in the physical aperture
- The collimation insertion would provide horizontal cut at 11 σ

Particles distribution inside the bunch

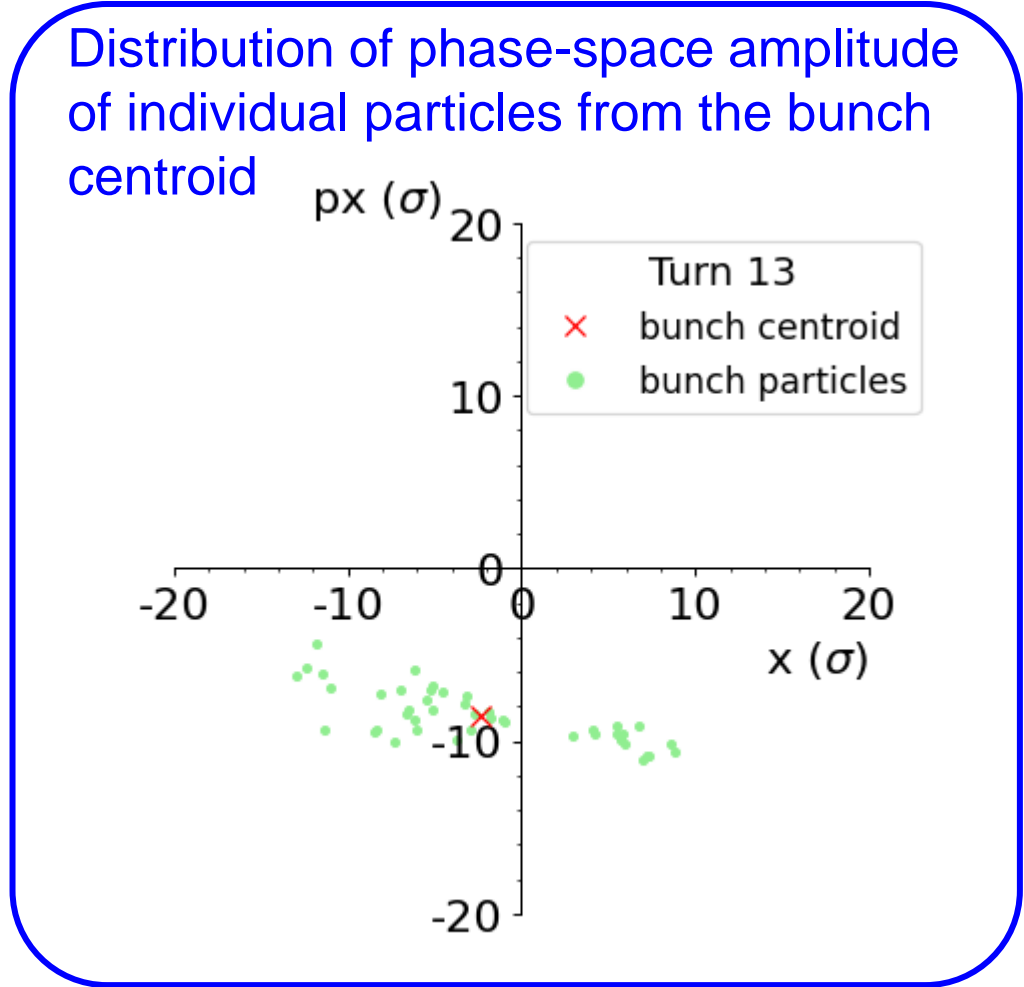
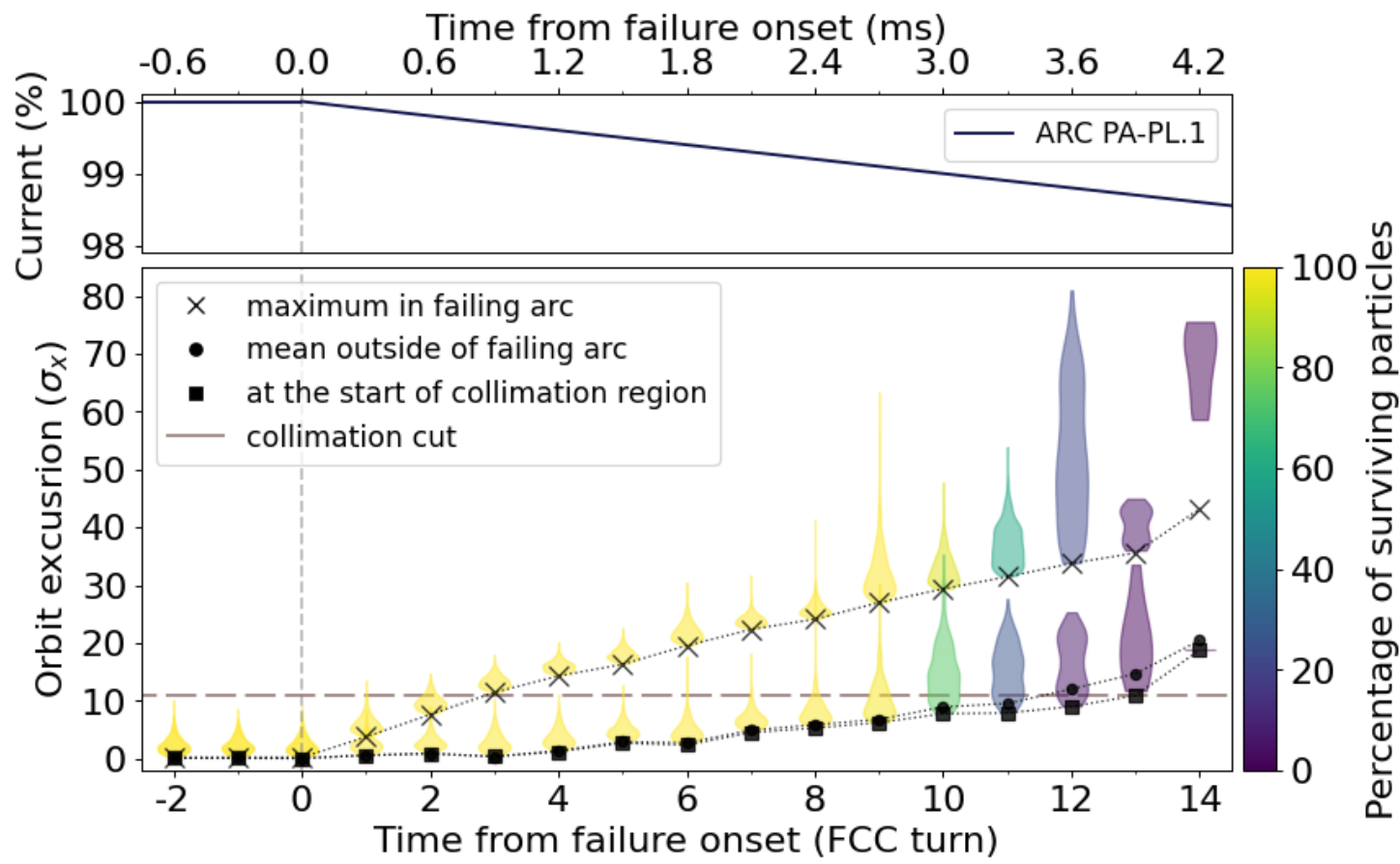
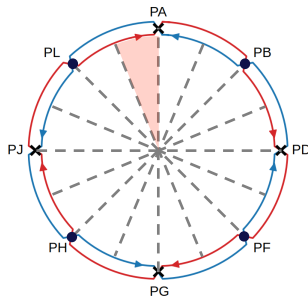

Particles losses

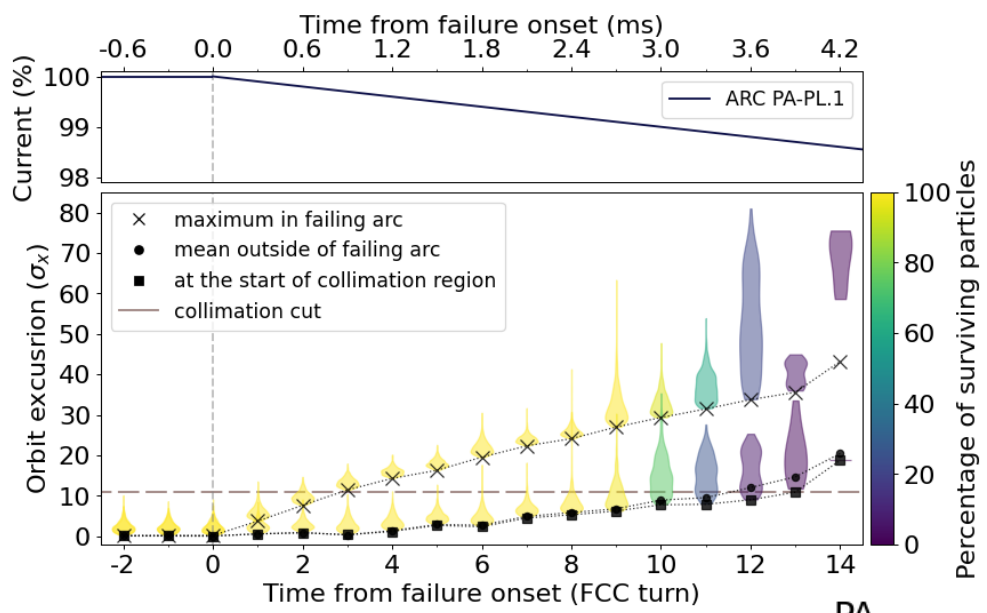
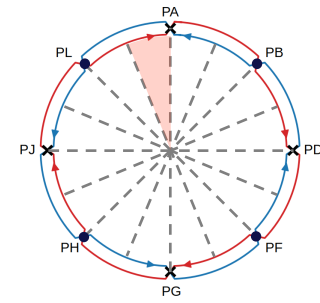

Loss map (no collimation cut)

- Lattice horizontal bottleneck ($12.8 \sigma_x$), final focusing magnet (QC4L)
- Losses in the arc

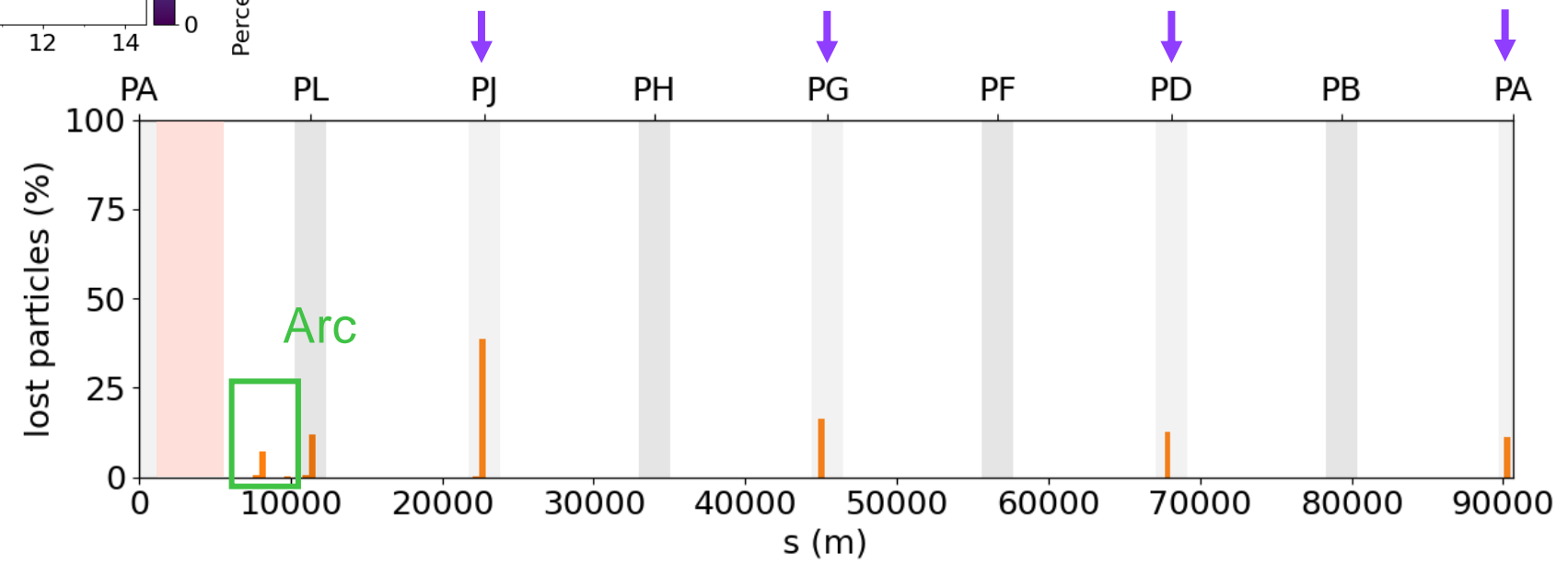

Failure analysis: half-arc PA-PL.1

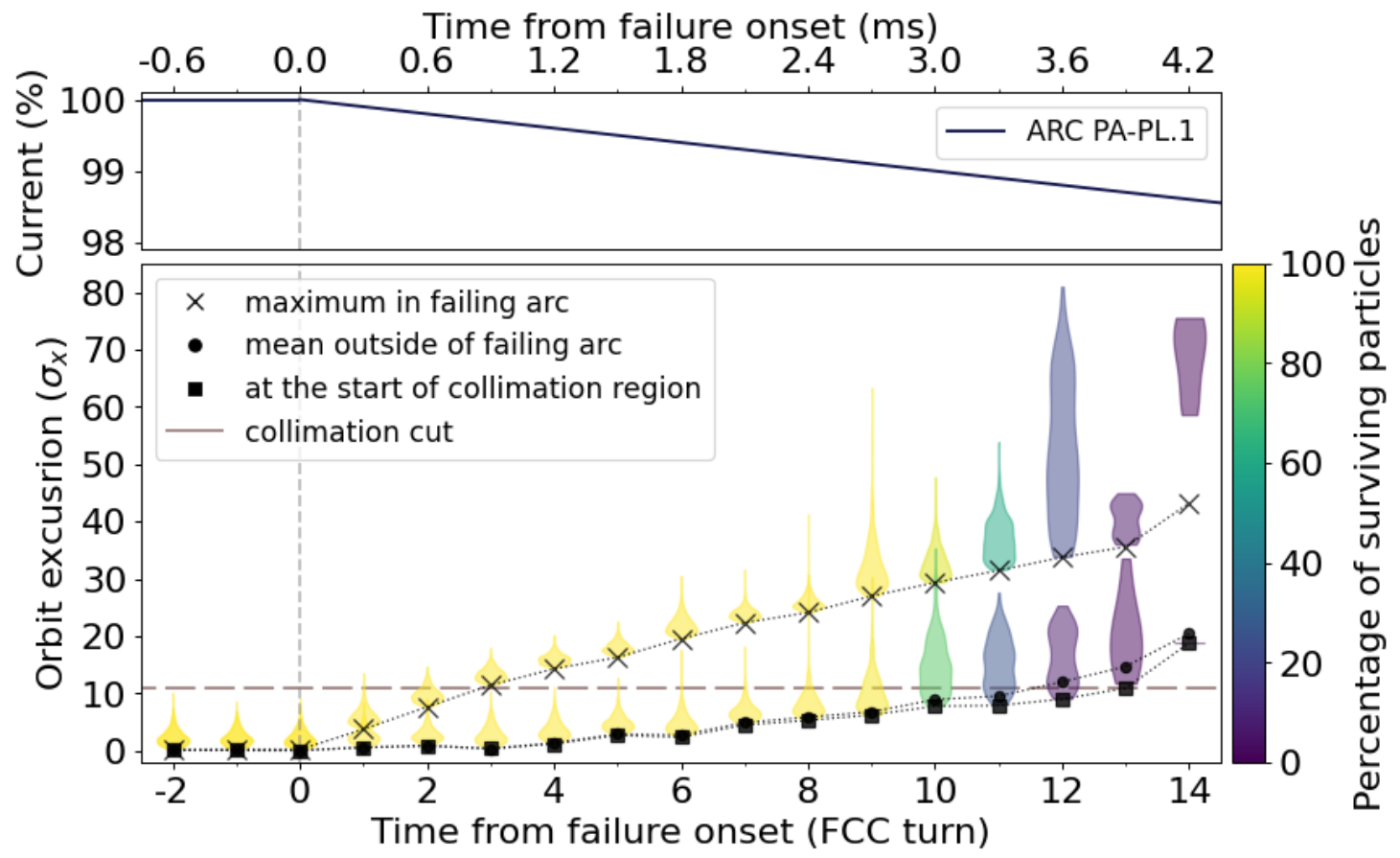
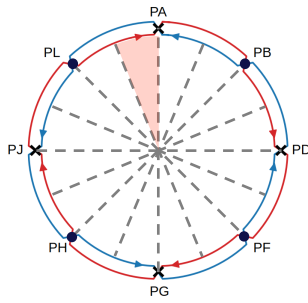

11 σ orbit excursion

Inside "failing half-arc"	3 turns
Outside "failing half-arc"	12 turns

Particles losses

Start of loss	Turn 8
Time to lose all particles	6 turns

Beam blow up

Bunch deformation with the failure development

Failure analysis: different half-arc (PL-PJ.1)

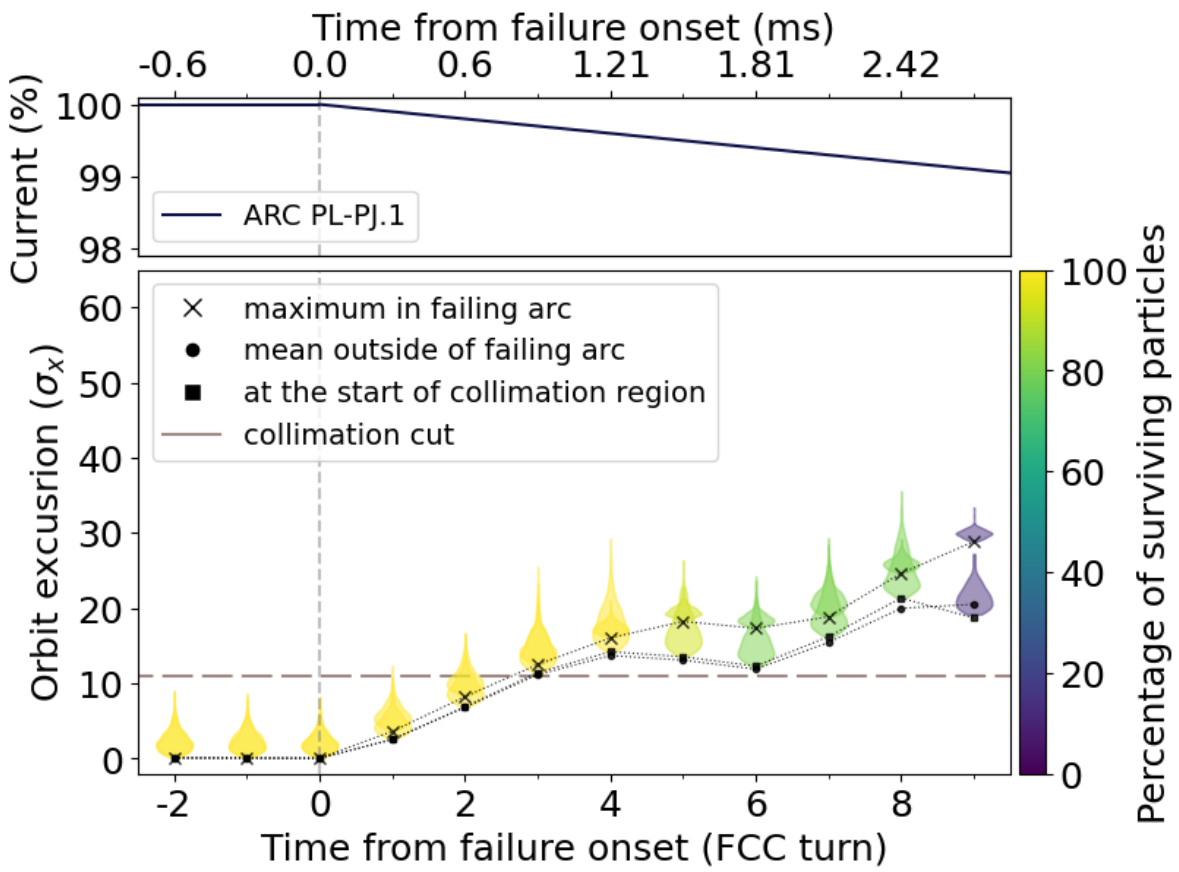
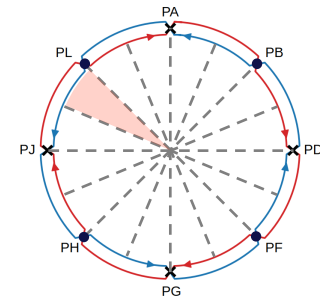

Most critical case – fastest beam loss

11σ orbit excursion	
Inside “failing half-arc”	3 turns
Outside “failing half-arc”	3 turns
Particles losses	
Start of loss	Turn 5
Time to lose all particles	5 turns
Beam blow up	
Limited blow up during the failure	

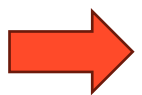

Very critical failure requiring mitigation and hardware interlocks

How to protect against fast failures ?

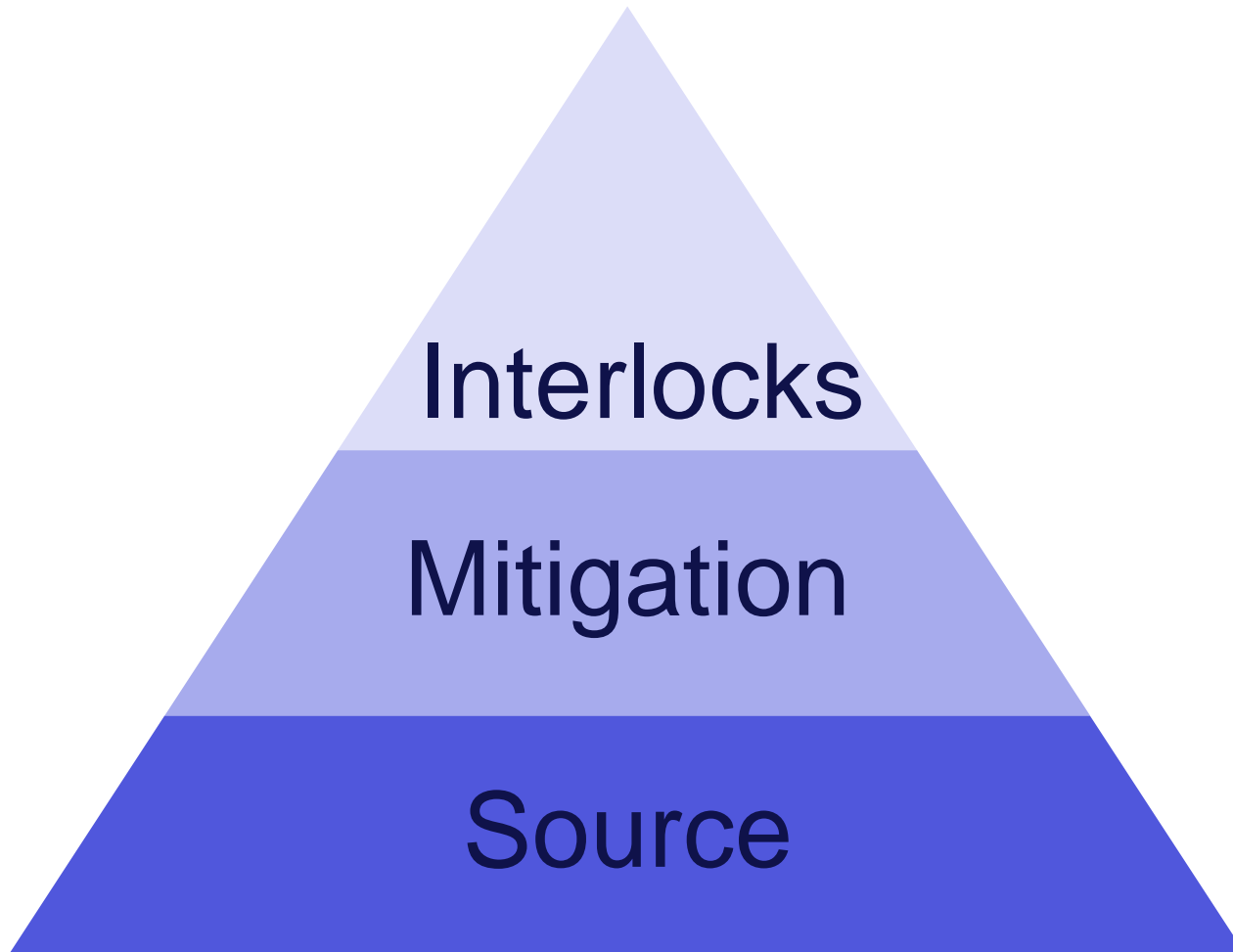

Interlocks required to protect the machine and trigger the beam bump before significant effects take place

- Full system developed for LHC
- Direct or indirect interlocks

Reduce the criticality at the source

- Slow down the dynamics
- Reduce the impacted part of the machine

Preventing the failure from happening

- Ensure the stability of the electric network
- Design reliable power converters

Failure mitigation

Increase of the circuit time constant: $\tau = 0.6 s$

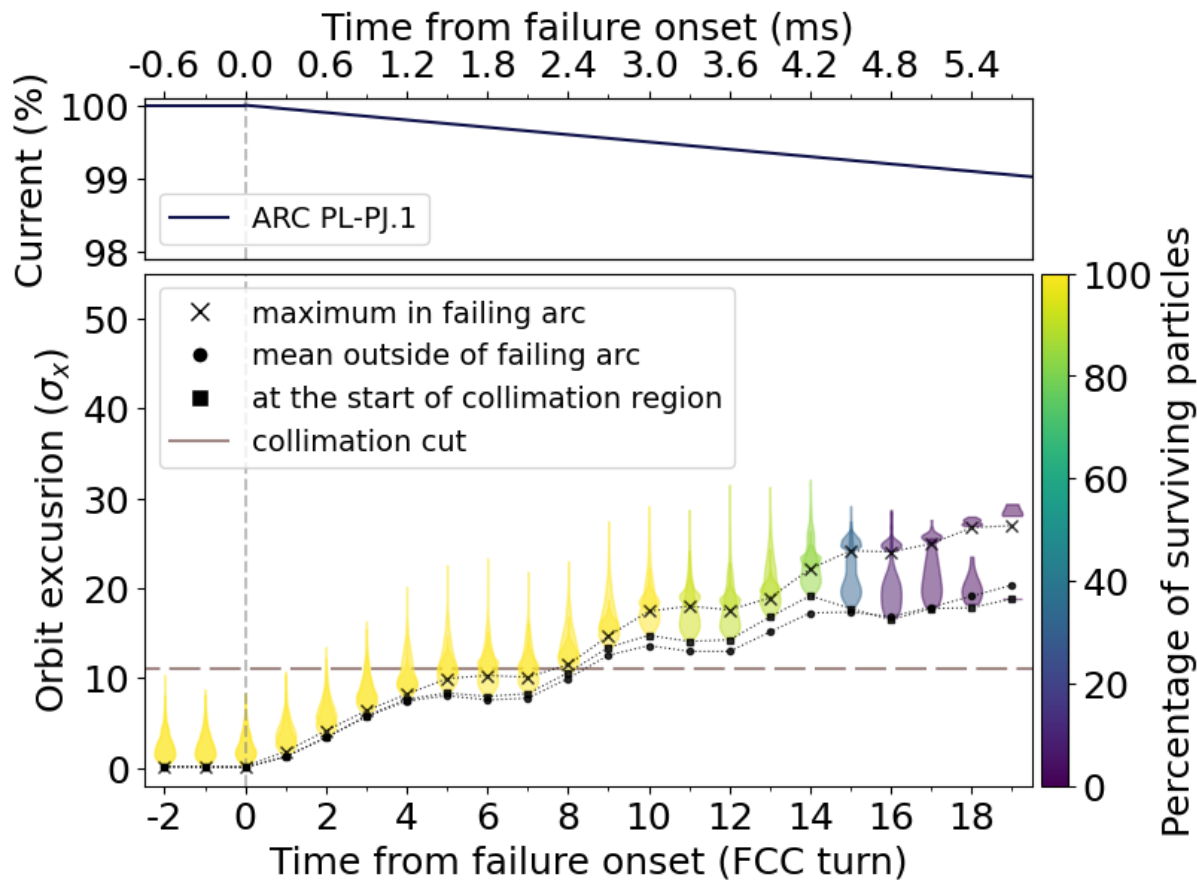
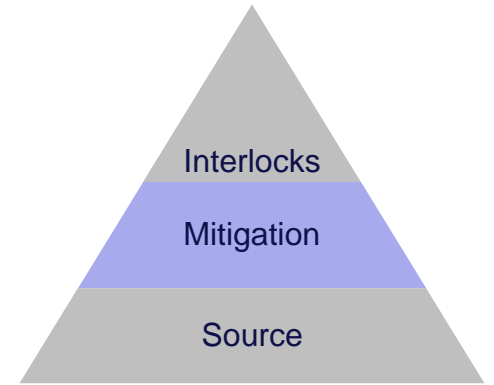

- Add element with larger inductance-to-resistance ratio in the circuit
 ⇒ feasibility to be discuss with the system experts
- Slows down the failure dynamics

Half-arc PL-PJ.1	$\tau = 0.3 s$	$\tau = 0.6 s$
Time to 11σ	3 turns	8 turns
Start of particle losses	Turn 5	Turn 11
Time to lose the beam	9 turns	19 turns

Direct interlocks

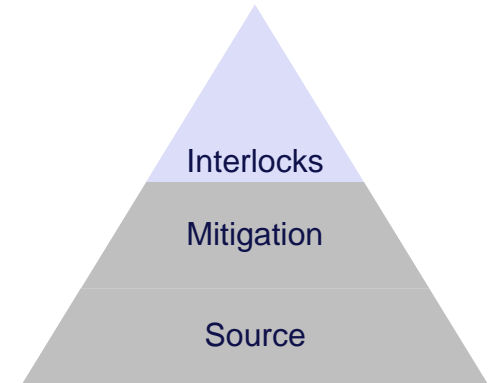

Interlock at the failure source

- Interlocking in the hardware fault status
 - Might be too slow
- Interlocking on the abrupt current change in the circuit
 - Fast Magnet Current change Monitors (FMCM) as at LHC and SPS
 - Reliable hardware system
 - Detection in a few microseconds

Indirect interlocks

Interlocking on beam-based measurements

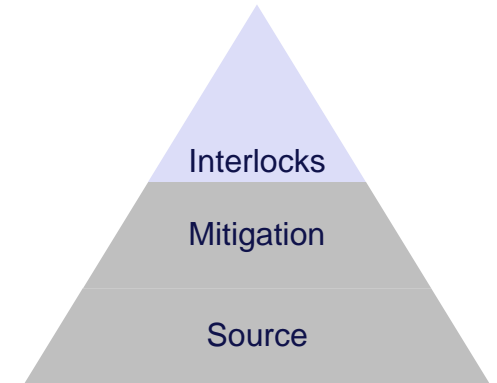

- Beam Loss Monitors (BLMs)
 - Safety net detecting particles losses in the collimation insertion and along the machine
 - Limited particle losses before significant orbit excursion might lead to a too slow reaction
- Beam Position Monitors (BPMs)
 - BPMs will be installed along the machine
 - Designed to have a precision of a fraction of sigma in the arcs
 - Hardware interlock
 - Required threshold tuning to interlock on failure and not on normal operation oscillations

On-going work on simulation model

- Detailed collimation insertion to be included
 - Realistic loss-maps and impact on the collimators (energy deposition studies)
 - Will provide refined estimate on required interlock reaction time
- Beam-beam and beamstrahlung effects
 - Failure development leads to loss of beam-beam interactions leading to further orbit changes and possible instabilities
- Alignment errors, coupling, experimental solenoids, transverse damper, etc.
 - Can influence the beam dynamics and change the failure development

FCC-ee halo collimation system

- Dedicated halo collimation system in PF (new version compared to FCC week 2023)
 - Dedicated collimation optics (M. Hofer)
 - Two-stage betatron and off-momentum collimation system in one insertion
 - Ensure protection of the aperture bottlenecks in different conditions
 - Aperture bottleneck at Z: 14.6σ (H plane), 85σ (V plane)
 - First collimator design for cleaning performance
 - Ongoing studies for optimizing the collimator design (G. Broggi – IPAC'24 paper)

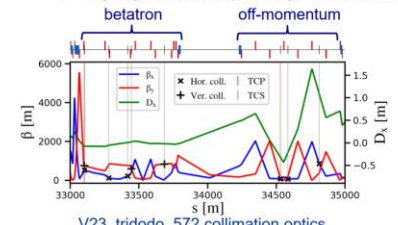
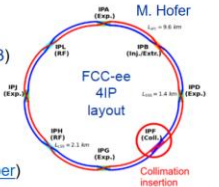

FCC-ee beam halo collimator parameters and settings

Name	Plane	Material	Length [cm]	Gap [σ]	Gap [mm]	δ _{cut} [%]
TCP H B1	H	MoGr	25	11	6.7	8.9
TCP V B1	V	MoGr	25	65	2.4	-
TCS H1 B1	H	Mo	30	13	3.8	0.7
TCS V1 B1	V	Mo	30	75	2.5	-
TCS H2 B1	H	Mo	30	13	5.1	90.6
TCS V2 B1	V	Mo	30	75	3.0	-
TCP HP B1	H	MoGr	25	18.5	4.2	1.3
TCS HP1 B1	H	Mo	30	21.5	4.6	2.1
TCS HP2 B1	H	Mo	30	21.5	10.8	1.6

Further materials will be studied in the future

G. Broggi, "FCC-ee collimation", FCC week 2024.

Introduction Simulation tools

Circulant Matrix Model (CMM)

Use linear algebra on a one turn matrix that represents a system, applied on discretized longitudinal phase space

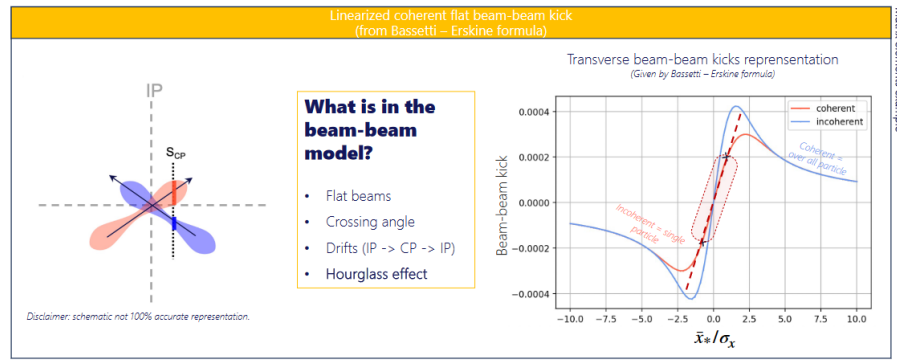

R. Soos, "Xsuite and Circulant Matrix Model simulations for FCC-ee beam-beam and wakefield effects." FCC week 2024.

Conclusions

- **Main dipole circuit powering failure is highly critical**
 - Very short circuit time constant: $\tau = 0.3 \text{ s}$
 - Very fast beam loss with significant orbit excursion: 11σ within 3 turns
- **Study mitigation at the source** to relax the constraints on the machine protection systems
 - Electrical network
 - Power converter reliability
 - Circuit time constant
- **Study interlocking**
 - At the source (FMCM)
 - On the beam effects (BPMs)

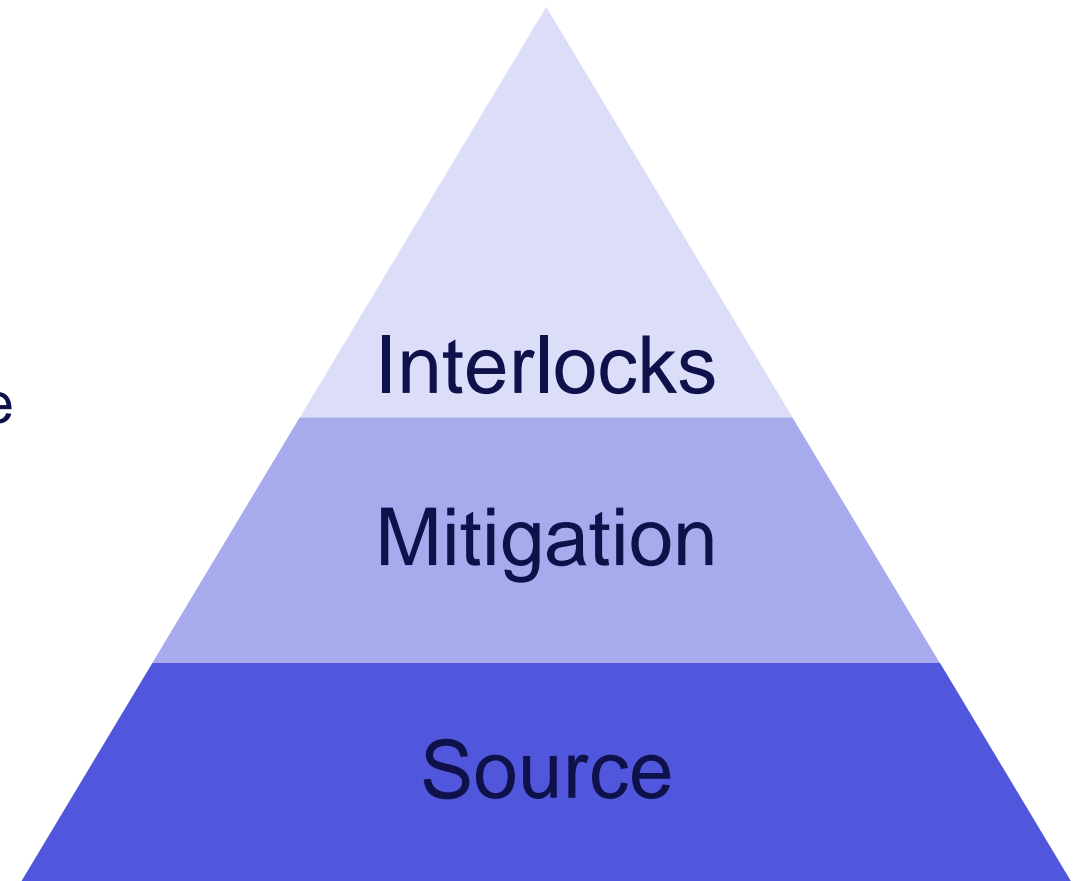



Backup slides

Circuit time constants

Comparison with LHC

FCC-ee arc magnets	τ (s)
Dipoles	0.3
Quadrupoles	2.14
Sextupoles	0.23
LHC warm bending magnets*	τ (s)
Separation dipole D1 (MBXW)	2.038
Horizontal orbit corrector (MCBWH)	0.420
Vertical orbit corrector (MCBWW)	0.423
Short module dipole (MBXWS)	0.651

* A. Alonso. *Most probable failures in LHC magnets and time constants of their effects on the beam*, 2006.
<https://cds.cern.ch/record/1003375/>

Comparison of different failing half-arcs

≠ phase advance across the half-arcs ⇒ ≠ behavior for the bump closure ⇒
≠ failure development

