



BLM system for FCCee

B.Salvachua, CERN SY-BI-BL

With inputs from the Machine Protection Task Force and contributions from:
E.Effinger, B.Humann, A.Lechner, T.Lefevre, S.Morales, F.Titz, C.Zamantzas

FCC Week 2025 22/05/2025 Machine Protection and Availability Session



Outline

- **Main purpose and functionality of a beam loss system**
- **Proposal of BLM system layout for FCC-ee**
- **Considerations on BLM electronics**
- **BLM specifications for the ARC**
- **Status of detector simulations**
- **Conclusions**

Beam Loss Monitoring on Particle Accelerators

The main functionality of the beam loss system is:

- Detect beam losses fast enough to protect accelerator components and trigger a beam extraction **for machine protection**.
- Provide regular measurements of the amount and location of beam losses for **machine optimization and performance**.

The requirements of the beam loss system will depend on:

- Physical coverage: do we need monitoring in all the arc?
- Required time and signal resolution: how fast or slow the beam can be lost? What is the smallest difference that needs to be detected?
- Required sensitivity: what is the smallest loss that needs to be detected?
- Required dynamic range: what is the largest loss that needs to be detected?

This depends on the type of losses we need to detect: at warm magnets, at super-conducting magnets, at collimators, etc...

LHC BLM system

Nearly 4000 ionisation chambers cover the 27km of the LHC. Primary losses are concentrated at the collimators and around the colliding points. Providing measurements with **12 integration times between 40 μ s – 86 s**. Can trigger a **beam extraction within 3 LHC turns (3 x 89 μ s)**

In addition, diamond BLMs at selected locations providing bunch-by-bunch measurements and Secondary Emission Monitors to increase the dynamic range of the system.

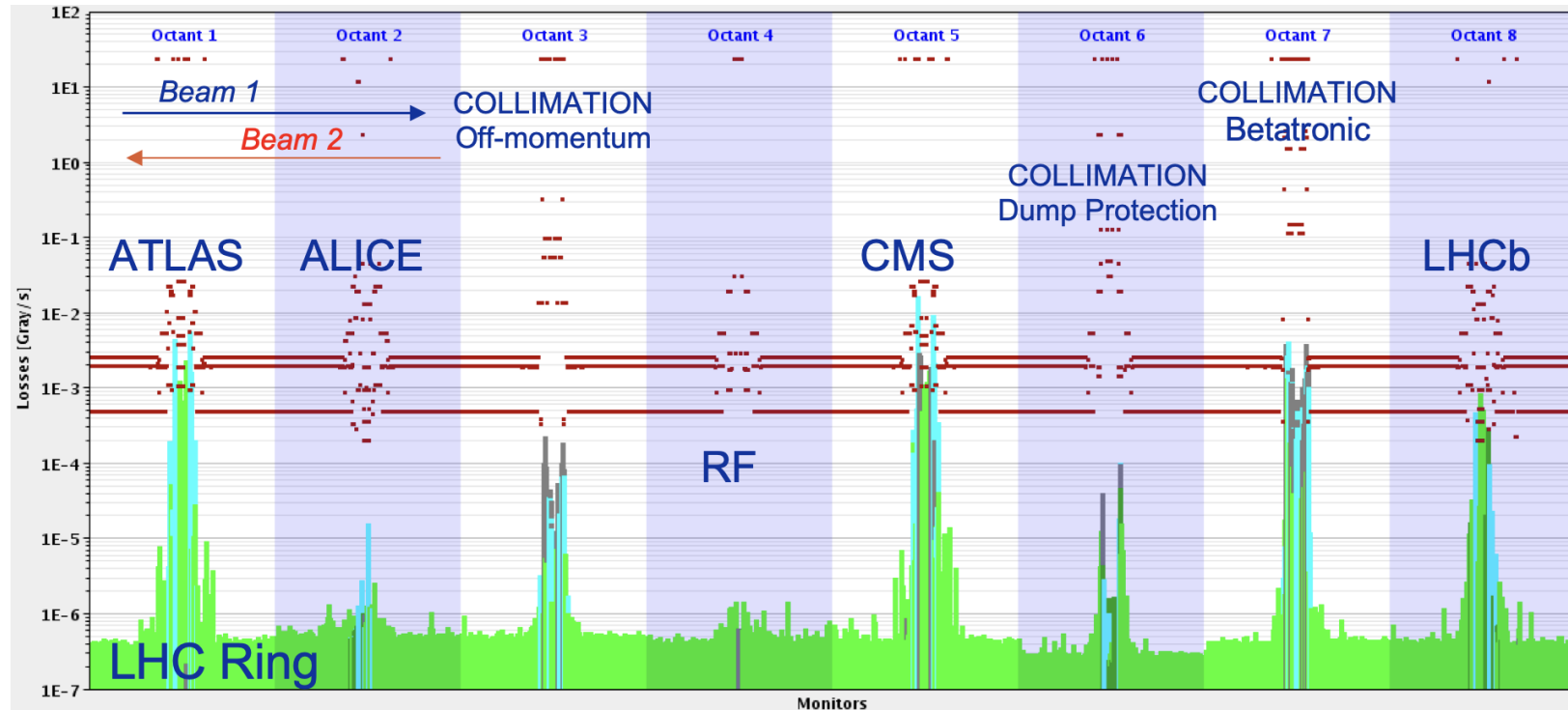

Beam Loss Measurements at LHC I

Many examples on how the Beam Loss System is used at the LHC, in addition to its Machine Protection functionality.

Online measurement of Beam Lifetime

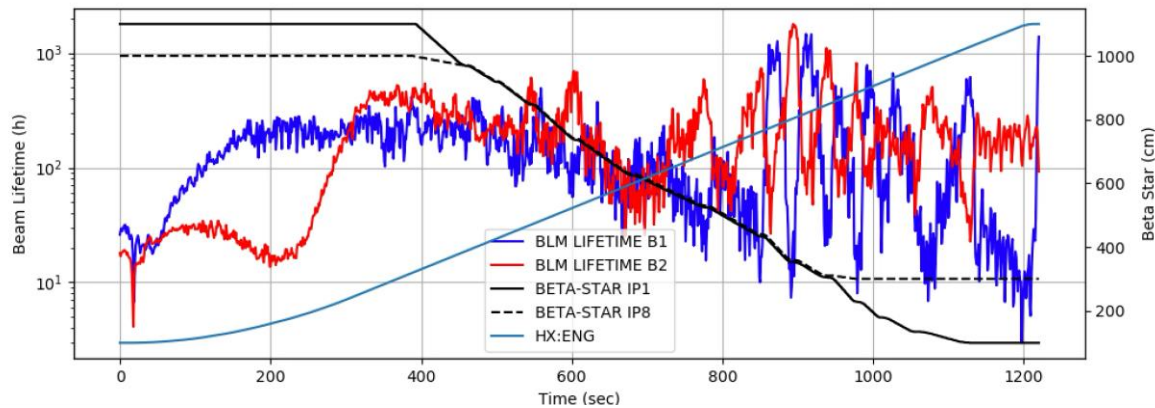

2023 protons at top energy - Beam 1

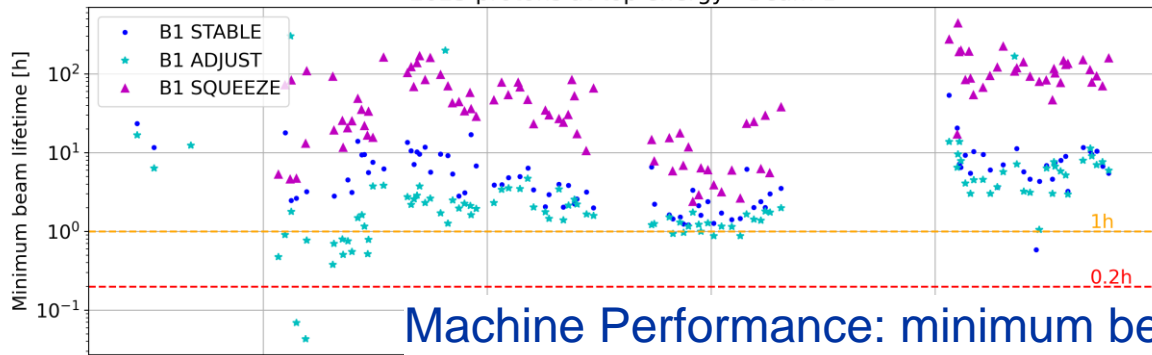

Machine Performance: minimum beam lifetime through the LHC cycle

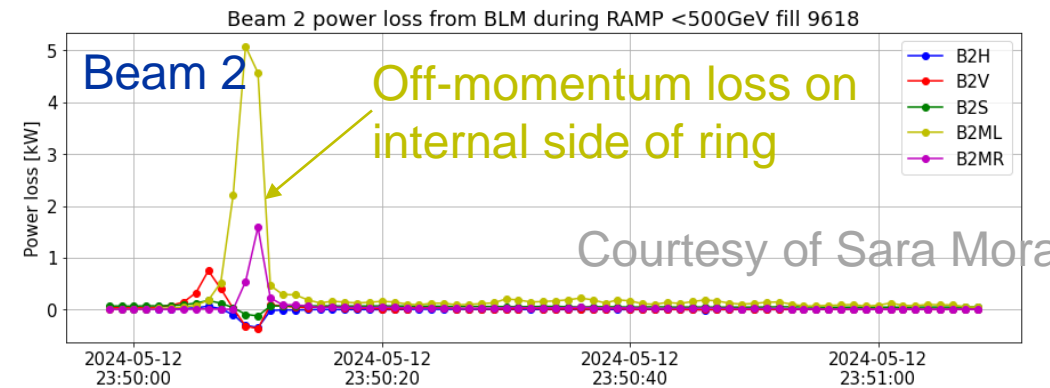
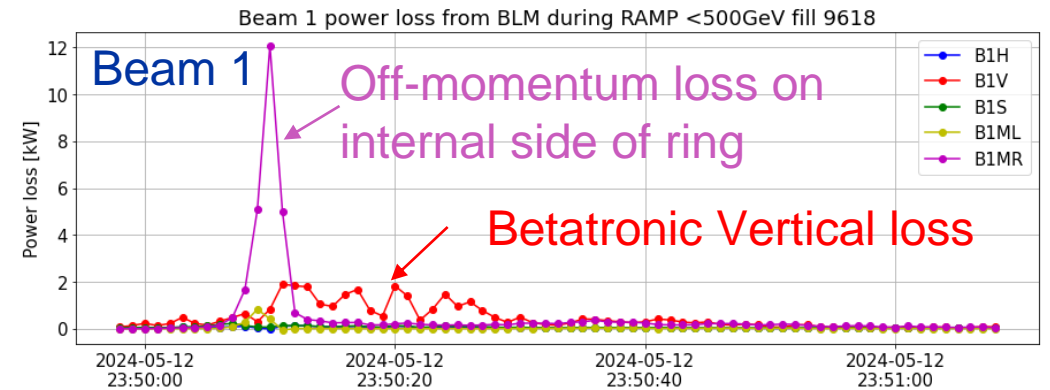

Courtesy of Sara Morales

Beam Loss Measurements at LHC II

Automatic Collimation Alignment – improving alignment time from days to minutes



Bunch-by-bunch diagnostics

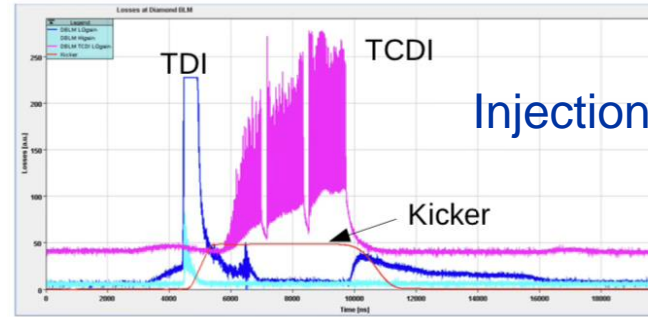

Detection and study of beam losses created by dust particles (UFO, ULO, etc.)

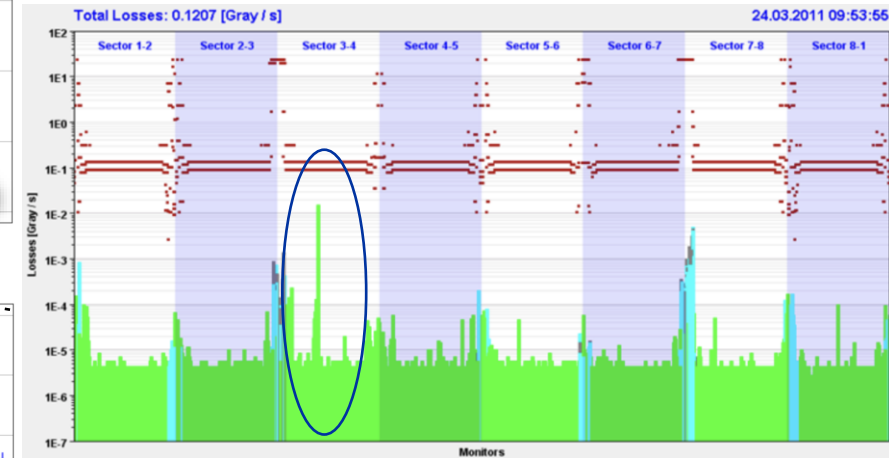
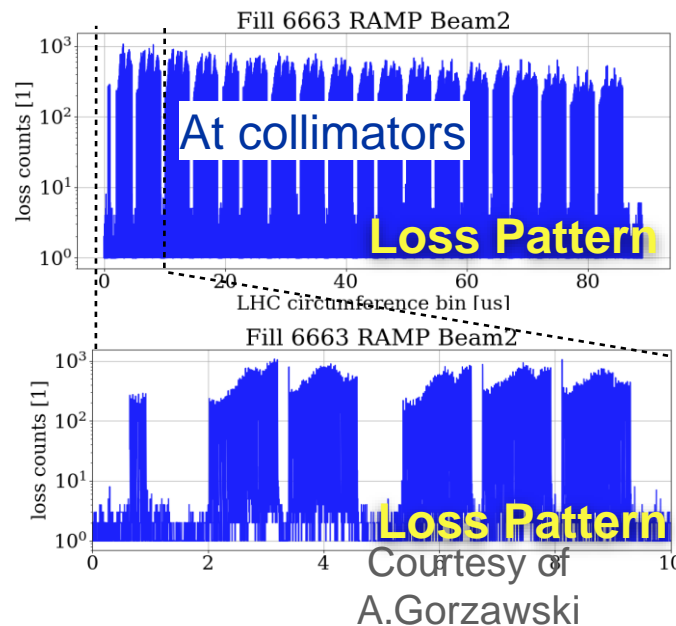

Courtesy of A.Gorzawski

FCCee beam parameters

FCC_turn (325.8us)

	HL-LHC	Z	V	W	W
Beam Energy [GeV]	7000	45.6	8		
Particle	<i>p</i>				
Nb. bunches	2748	11200	17		
Beam current [mA]	1090	1270	1		
Bunch Intensity [10^{11}]	2.2	2.14	1.		
Stored beam energy [MJ]	678	17.5	3		
Geom. emittance hor. ϵ_x [nm]	0.34	0.71	2.		
Geom. emittance ver. ϵ_y [pm]	340	1.9	2		
Hor. beam size $\beta_x = 50$ m [μm]	130	188	329	188	282
Ver. beam size $\beta_y = 50$ m [μm]	130	9.7	10.5	8.4	8.9
Energy density [MJ/mm^2]	40 118	11 082	682	645	87.2

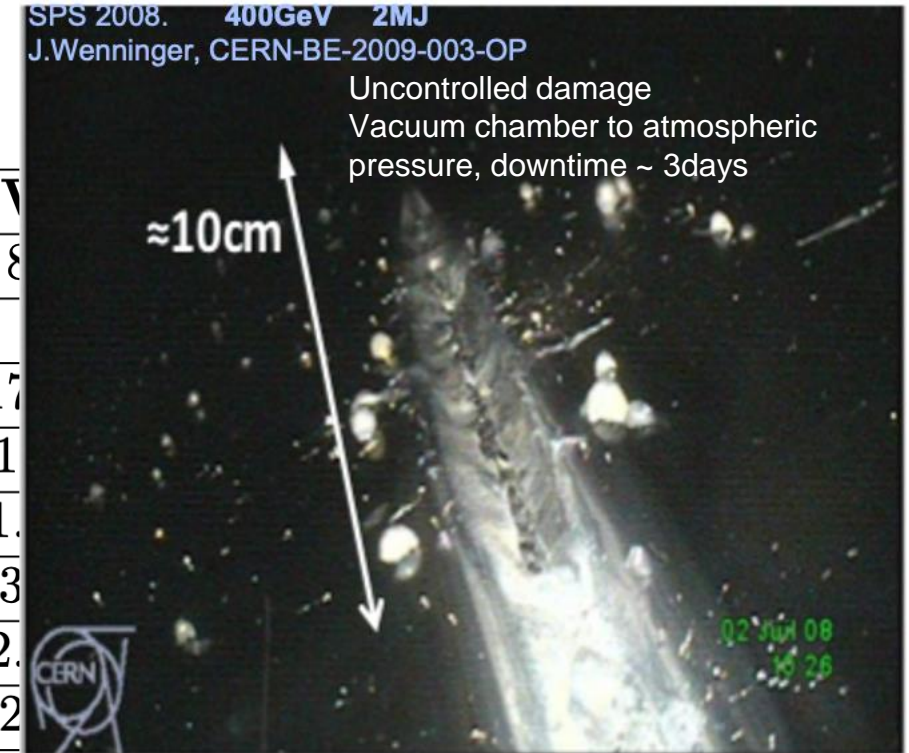

Energy densities at the Z-pole configuration of the same order of the HL-LHC.

Active Protection is needed to minimize failure occurrence

Very challenging to detect on time vertical losses with such small beam size

Where do we need to measure Beam Losses?

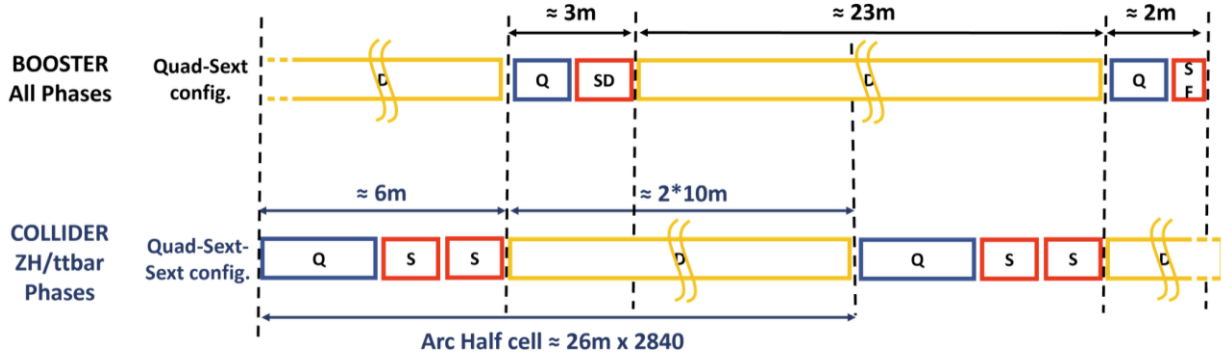
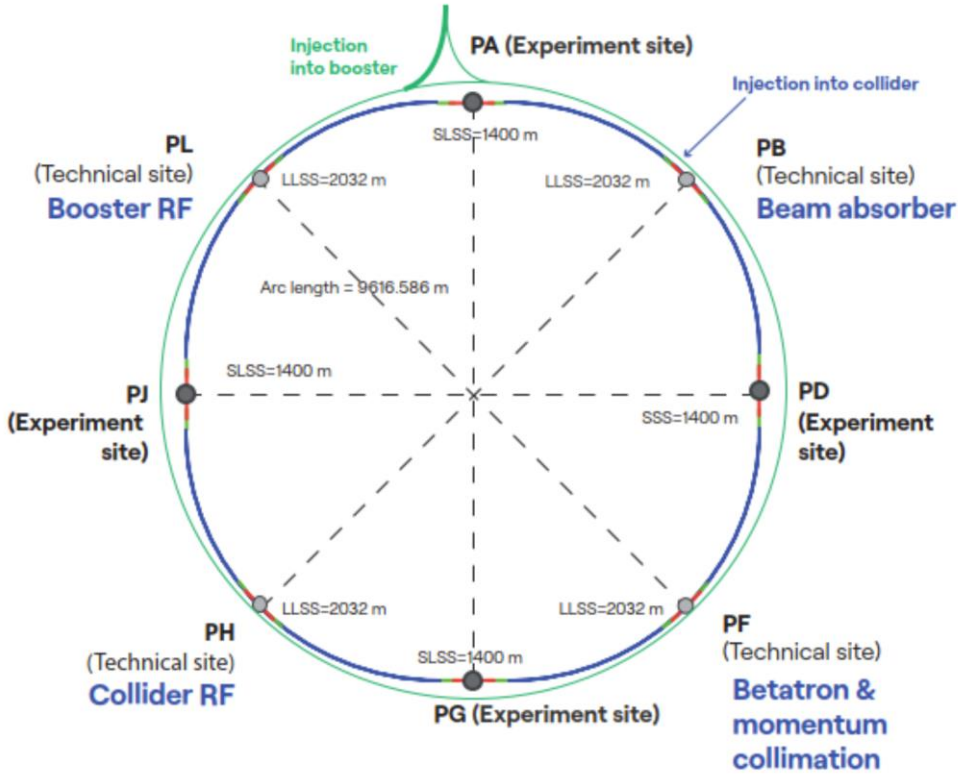

Fig. 3.69: Azimuthal shift between booster and collider - collider optics V24.3_GHC and booster optics V24_FODO.

Important for diagnostics, commissioning and beam tests more than for protection

	Elements Protected or Monitored	Element	Desired time	
8 ARCs	~1500	Arc cell of collider ring	Slow (μ s)	Per turn measurement
8 ARCs	~1500	Arc cell of booster ring	Slow (μ s)	Per turn measurement
PA/PD/PG/PJ + PF	~100	Collimators and absorbers	Fast (ns)	Per bunch measurement
PA/PB	~200	Injection and Extraction system	Fast (ns)	Per bunch measurement

FCC-ee proposal of a BLM system in the ARC

Generic Beam Loss System covering an ARC cell. The final detector technology will depend on the beam loss measurement requirements (time and signal resolution, etc.)

BLM system = 3 BLM read-out channels (black boxes)
 Proposal of 2 BLM systems / arc cell / beam

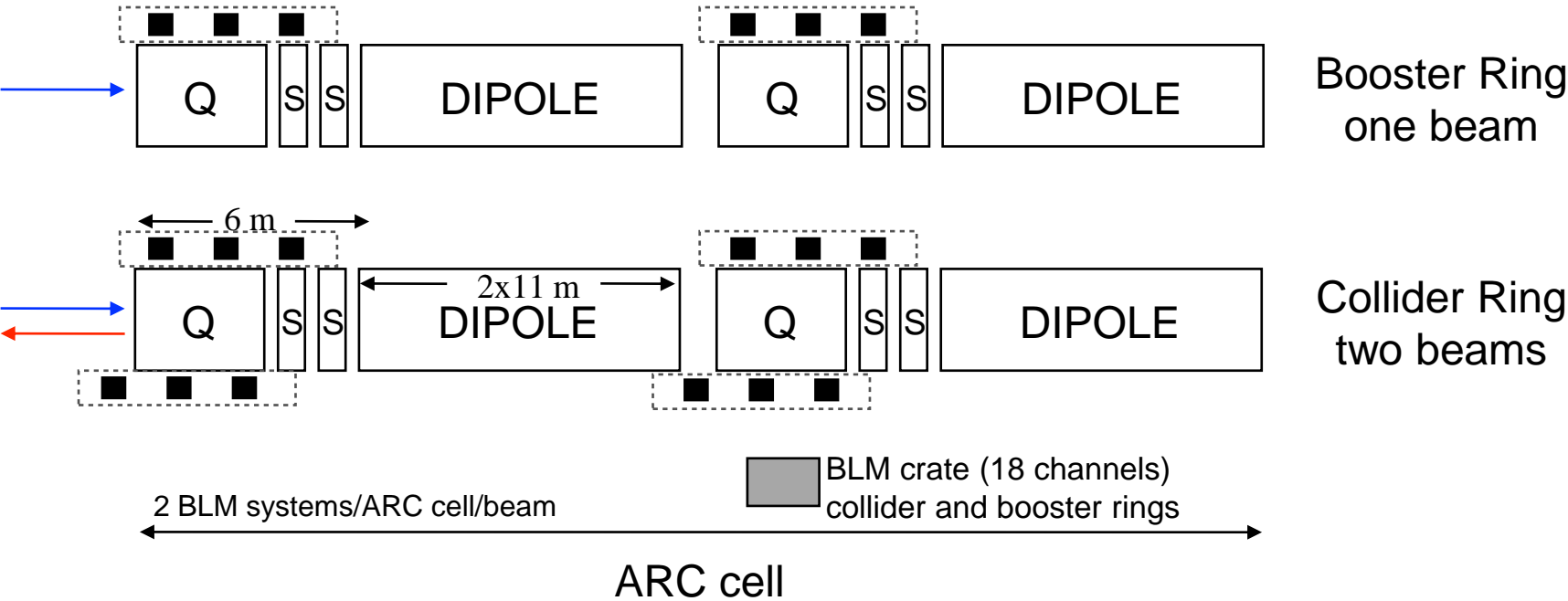

- 3 read-out channels/beam (minimum to localise losses)
- Final location being studied (see next slides)
- Slow read-out: per turn (μs)
- SR background needs to be considered

BLM read-out electronics for the ARC

Long copper cables need to be avoided:

- Signal deterioration: very low signals [pA-mA] range
- Cable trays capacity overload

Electronics in the tunnel will need to withstand high levels for radiation and high temperatures.

- Radiation tolerant electronics
- Active cooling

Proposal is to place the acquisition electronics close to the detectors and transport the measurements & diagnostics over digital optical links.

Radiation tolerant electronics

R&D on BLM radiation tolerant electronics ([CERN-THESIS-2022-333 F.Martina](#))

- HL-LHC and SPS upgrade during LS3 (2026-2029)
- 20 years lifetime with TID 6 x 6kGy
- Commercial products cannot fulfil this requirement
- Design of a new front-end board with an application-specific integrated circuit (BLMASIC)
- BLMASIC tested for TID up to 1MGy
- Complete front-end board tested for TID up to 3.3kGy

Expected Yearly dose levels:

At the tunnel walls: from <10kGy to 20kGy (B.Humann @ 13th FCC-ee Radiation and Shielding Meeting)

Inside the electronics bunker: around 10 Gy (A.Lechner: FCC-ee Radiation Environment and Shielding - IPAC 2025)

Top view of BLM front-end

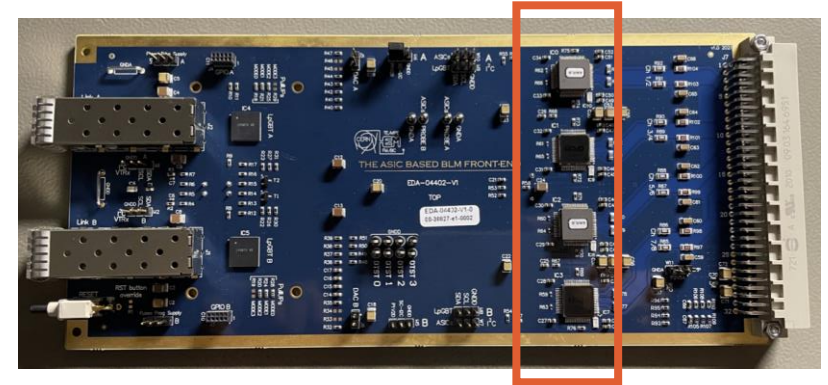

Optical transceivers

BLMASIC (v2 and v3)

A solution for electronics in the tunnel is possible: including radiation tolerant electronics + shielding

FCC BI Tunnel crate proposal

Proposal to install radiation tolerant electronics in racks below the magnets. Shielding against Synchrotron Radiation. Integration studies are on-going, evaluating the building of an electronics bunker to host the racks. **Key points** should be to **incorporate in the design a robotic solution** for replacement of cards, opening the bunker, etc.

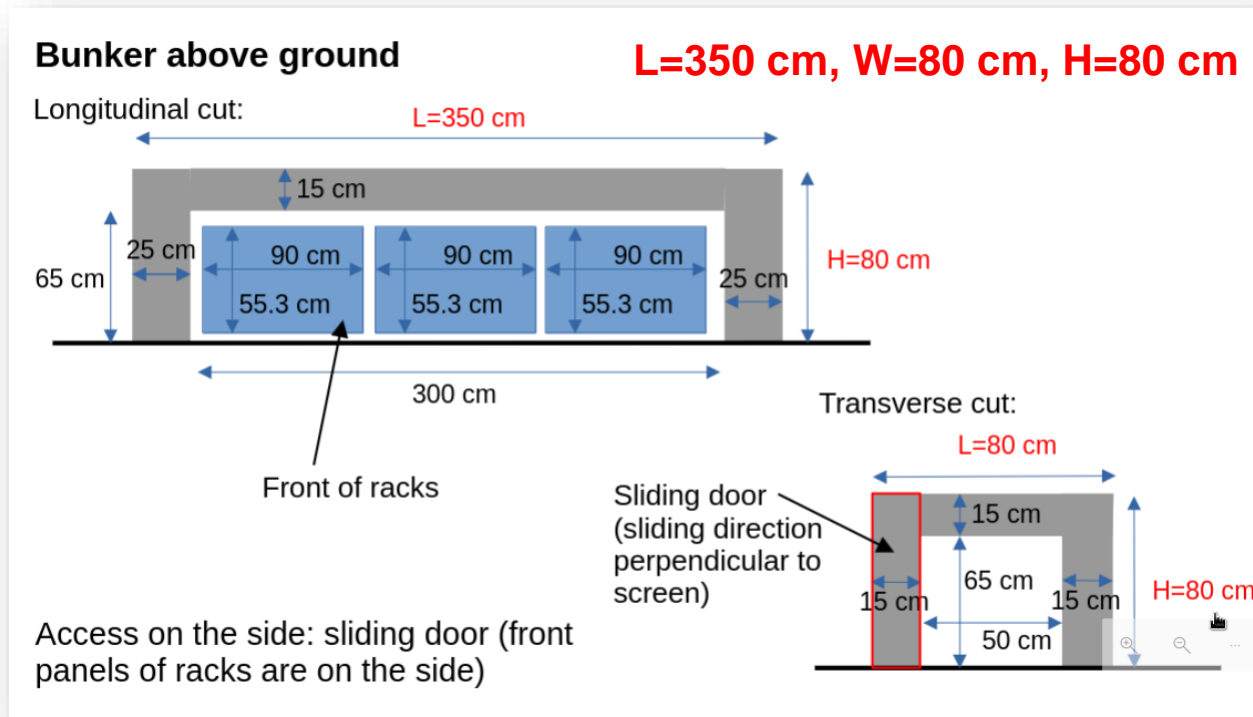

Backplane: providing all cabling and fiber connections.

Cooling: circulator and fans at the side (horizontal airflow). Accessible for exchange.

Shielding: movable on a rail. Robotic solution.

Electronic Modules: robotic solution to replace modules. Insert from front-panel and connections (copper and fibre).

See:

FCC-ee Radiation and Shielding WG:

<https://indico.cern.ch/category/17958/>

FCC BI rack dimensions

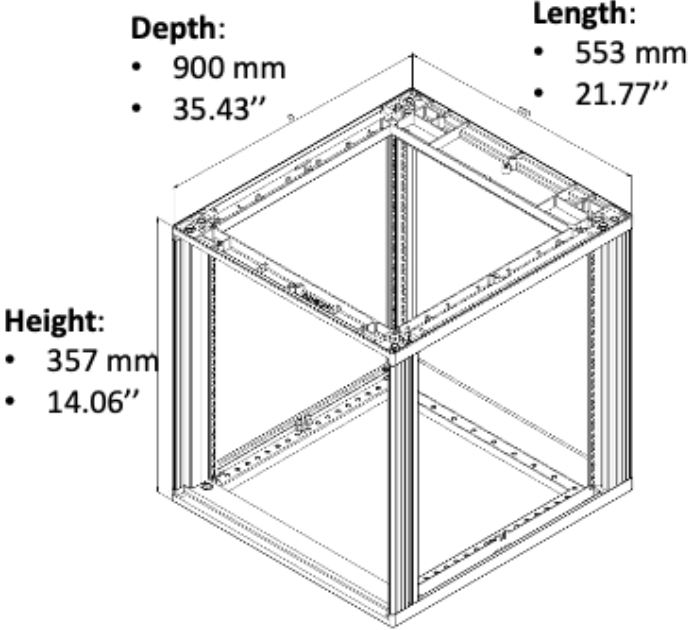

Front-panel on top
Connections and cooling on the bottom

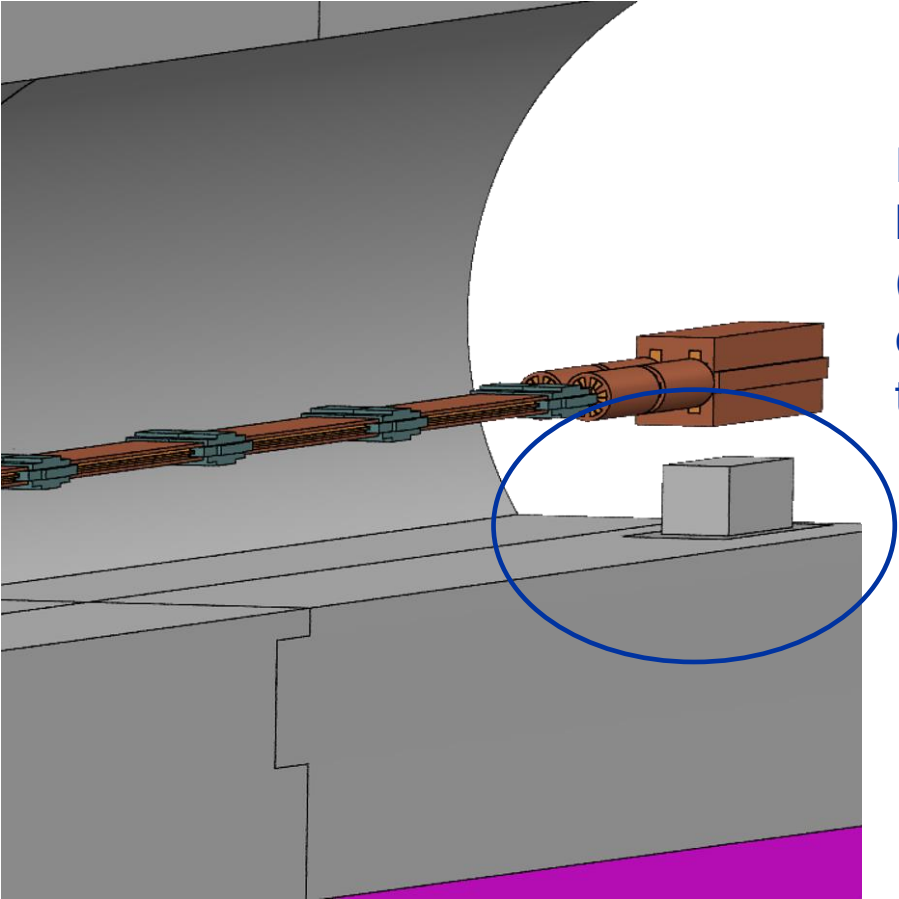

Electronics bunker hosting the BLM crates (and other equipment's crates) placed below the quadrupole

FCC BLM detector inventory

BLM system = 3 BLM read-out channels (black boxes)
 Proposal of 2 BLM systems / arc cell / beam

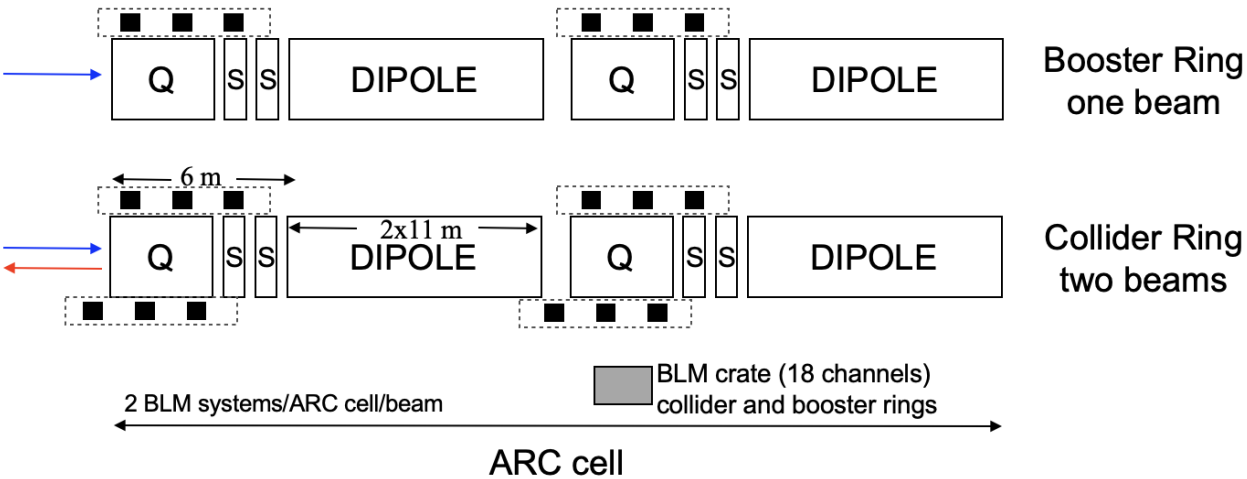

For BLM equipment 1 racks is needed per quadrupole to read-out Beam Loss Monitors and 2 racks per cell for the Beam Position Monitors

FCCee BLM system in the ARC:

	Collider	Booster	Total
BLM channels per quadrupole	6	3	9
BLM channels in the ring	17616	8808	26428
BLM crates per arc cell	1	0	1
BLM crates in the ring	1468	0	1468

Compared to the LHC BLM system:

LHC Run 3	arc cells	straight section	TOTAL
BLM channels per half-cell	6	-	6
BLM channels	2160	1545	3705
BLM tunnel crates	360	38	398
BLM surface crates	-	-	27
BLMED (CFC-cards)	-	-	669

And additional:

120 Little Ionisation Chamber (LIC)

167 Secondary Emission Monitors (SEM)

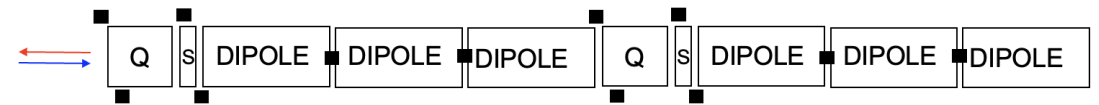

Fast Beam Loss monitors

A bunch-by-bunch system is proposed to monitor the losses at the injection/extraction and the circulating beam collimation system.

Collimator system:

- Beam halo cleaning, designed to protect the machine against beam losses
- SR cleaning, design to protect the experiment detectors against SR photons

Injection and Extraction:

- Monitoring is needed at the location of collimators, beam masks, absorbers and kickers and septum magnets.

Table 3: Fast beam loss monitors for Colliding and Booster ring, excluding injectors.

Purpose	Colliding ring	Booster ring	Total
Collimation Halo (IPF)	27/beam		54
Collimation SR (IPA/IPD/IPG/IPJ)	32/beam		64
Booster injection region		10/beam	20
Booster to Collider extraction		15/beam	30
Booster to Dump extraction		15/beam	30
Booster to Dump transfer line		(12+5)/beam	34
Booster to Collider transfer line		6/beam	12
Collider injection region	2/beam		4
Collider to dump extraction	15/beam		30
Collider dump line	(12+5)/beam		34
Total Injectors			200
Total Ring	93/beam	63/beam	312

Beam Loss Measurements specifications

What are the beam loss scenarios?

Where is the beam lost? And How?

Currently, all this is not yet defined

What is the Machine Protection strategy?

But we still need to certain specifications in order to start the needed R&D on a Beam Loss System for the FCCee.

Machine Protection Strategy

- ❑ For **hardware failures** the 1st interlock should come directly from the hardware.
 - **BLM is the second-net of protection**

- ❑ For **non-hardware failures** (i.e. beam instability) today we rely on **Beam Instrumentation Measurements**: Beam Loss System, Bunch Current Measurements, Beam Position Monitors, etc. This is **the first-net of protection**.

Beam loss scenarios

	Reason	Source of losses	Location of losses
Steady losses	Nominal machine - unavoidable	Beam halo at collimators	Collimators in PF Collimators in PA/D/G/J
		Beam gas interaction	Everywhere
		Synchrotron radiation	Everywhere
		Collisions products	Around colliding points PA/D/G/J
	Degraded machine	Vacuum degradation ,i.e. when installing new equipment	Local - several meters
Slow transient losses	Beam manipulations and measurements	Local orbit bumps, collapsing beam separation, squeeze, etc.	Local - several meters Collimators in PF
		Injection	Injection points
		Global corrections (tunes, coupling, etc.)	Collimators in PF
		Beam scans with wires, gas jets, etc.	Local - several meters
Fast losses	Kickers failure	Injection error	Injection points and Collimators in PF
		Dump error	Dump point and Collimators in PF
	Power converter trip	Magnets	Collimators in PF
	Degraded machine	Beam dust particle interactions	Local - several meters and Collimators in PF
	Beam Instabilities	Drifting beam or transverse blow-up	Collimators in PF

Not an exhaustive list but just a starting point

Several of these beam loss scenarios are already under study, see Presentation from G.Broggi

Beam effect on material damage

Used to determine Beam Loss Limits

Design of the LHC protection system is based on the assumption of damage limits

Simulations studies and beam tests have been done for more than 20 years:

- Multi-turn tracking simulations (in particular for Collimators)
- Energy deposition simulations (Monte Carlo)
- Thermo-mechanical simulations (finite element, heat and stress)

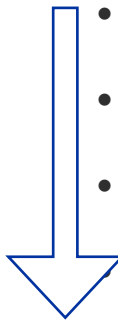

Verification with beam tests

Example: Material damage test with 450 GeV protons on copper ([link](#))

Remarkable agreement with simulations!

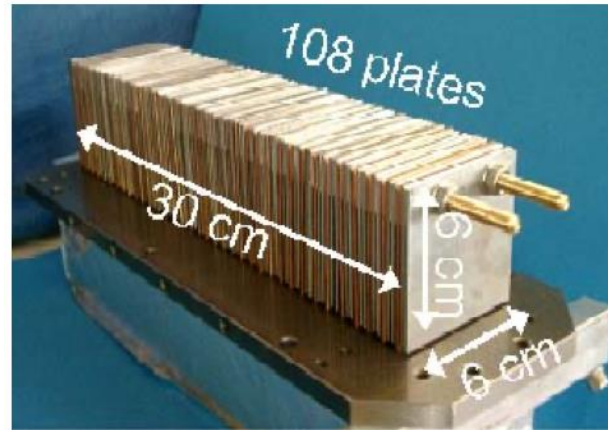

Sandwiched target irradiated with different intensities

7.9×10^{12} protons @ 450 GeV

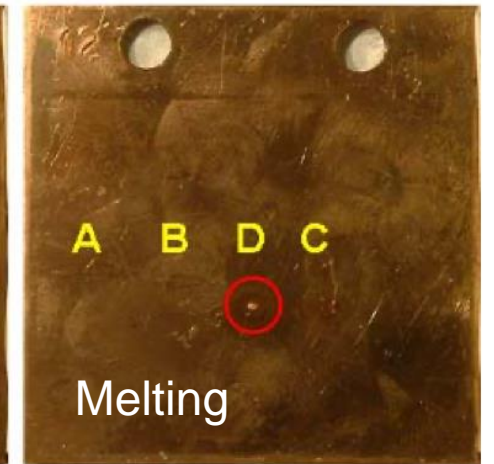
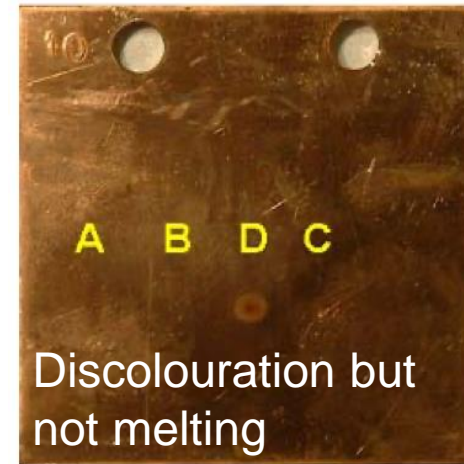

BLM in the ARC

Nearly 18000 BLMs are planned to cover the Colliding Ring Arc.

Being warm magnets the Beam Loss Monitoring strategy should be to avoid creating a hole in the vacuum chamber.

Direct beam impact into the magnet, which could be:

- In the synchrotron radiation absorbers: copper
- In the vacuum chamber: copper

When this happens we expect sudden energy deposition and increase of temperature.

While detailed studies need to be considered for the fine tuning of the amount of losses that can be withstood (thermal expansion, thermal shock, etc.). We can still make some approximations to estimate the maximum and minimum detection ranges based on previous studies.

Beam impacts needed to melt copper

As a 1st approximation, one can calculate the melting point and the equivalent energy deposition needed to reach the melting temperature.

Peak energy density for 1 bunch impacting in copper at the different FCCee beam energies.

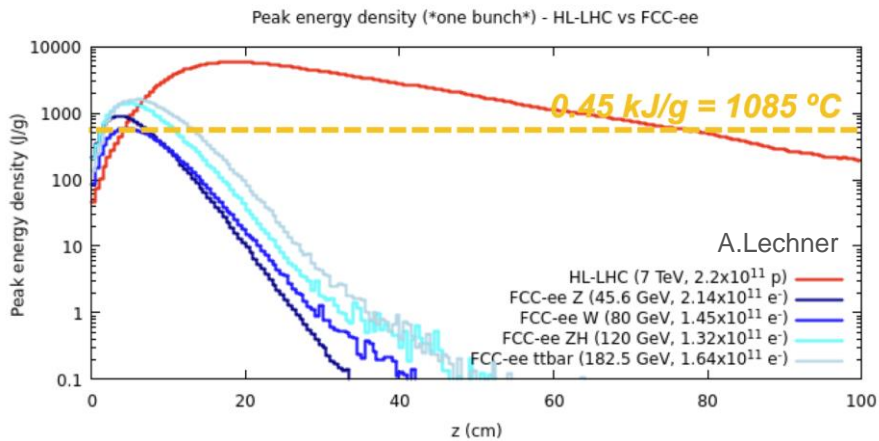

1st approximation

$$\Delta T = \frac{\Delta E}{\Delta V} \frac{1}{C_P \rho}$$

	Copper	Tungsten
Melting temperature of materials	1084.62 C	3422 C
Melting temperature of materials	1357.79 K	3695.15
Densities, ρ	8.96 g/cm ³	19.3 g/cm ³
Heat Capacity, C_P	0.385 J/g/K	0.134 J/g/K
Energy Deposition for Melting	4.5 kJ/cm³	9.4 kJ/cm³
BLM Detection (0.01%)	0.45 J/cm³	0.94 J/cm³

<https://www.americanelements.com/meltingpoint.html>

https://www.engineersedge.com/materials/densities_of_metals_and_elements_table_13976.htm

	Energy	Bunch Intensity	Bunch fraction needed to melt copper
HL-LHC	7 TeV	2.2x10 ¹¹ p	7%
FCC-ee (Z)	45.6 GeV	2.14x10 ¹¹ e ⁻	50%
FCC-ee (W)	80 GeV	1.45x10 ¹¹ e ⁻	75%
FCC-ee (ZH)	120 GeV	1.32x10 ¹¹ e ⁻	30%
FCC-ee (ttbar)	182.5 GeV	1.64x10 ¹¹ e ⁻	28%

First specifications for the ARC BLM is that it should be able to detect:

- at least 0.01% of this type of losses
 - Up to 10 times this damage limit
- Assuming 5 orders of magnitude

LHC Beam Loss Monitors

Ionisation chamber (3600 detectors):

50 cm cylindrical tube with parallel aluminium electrodes plates (each 0.5 cm)

Filled with N₂ gas at 100mbar overpressure (1.1 bar) and HV 1.5 kV

1.5 L of sensitive volume

Read-out:

Charge-to-Frequency conversion using radiation tolerant electronics with dynamic range > 10⁸ (from 10 pA to 1 mA)

Measurements in Gy/s in 12 moving windows ranging from 40 μs to 83.9 s

Allows the setting of unique beam extraction thresholds depending on the duration of the beam loss and the beam energy

Dynamic range defined by quench curves +
2 additional orders of magnitude

LHC turn is 89 μs

**Beam extracted
in ~ 3 LHC turns**

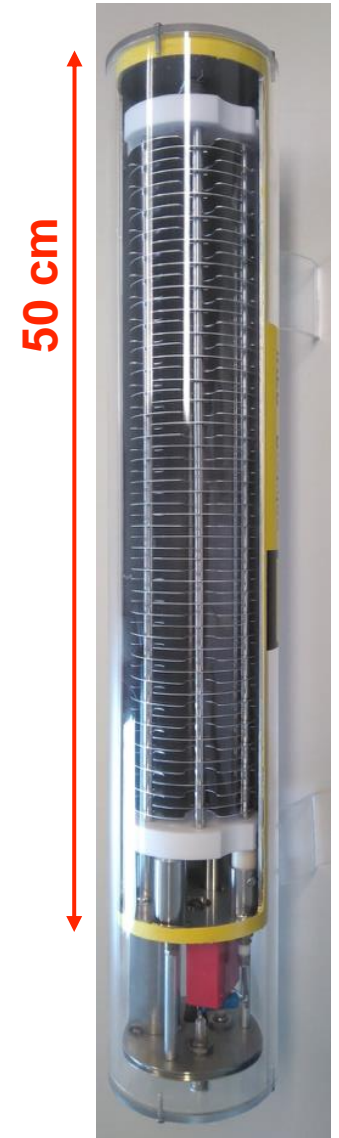

Simulation of beam losses and detector signal

Study basic parameters and ideas:

- Quantify if the assumption of 3 monitors / beam / half-cell is acceptable.
- Quantify the response of ionisation chambers to impacts on different locations of half-cell.
- Quantify the signal range of ionisation chambers by comparing them to existing systems.

How:

- Start with the Fluka simulation of LHC-type ionisation chambers along the FCC-ee dipole and quadrupole.
- Simulate different impact locations (i.e. SR absorbers, beam pipe, top, side, etc.) and compare the expected signal with BLMs located around and along the magnet.
- Compare the expected signal for different beam energies (i.e. Z-pole, W-pole, ZH, ttbar)

Beam
impact

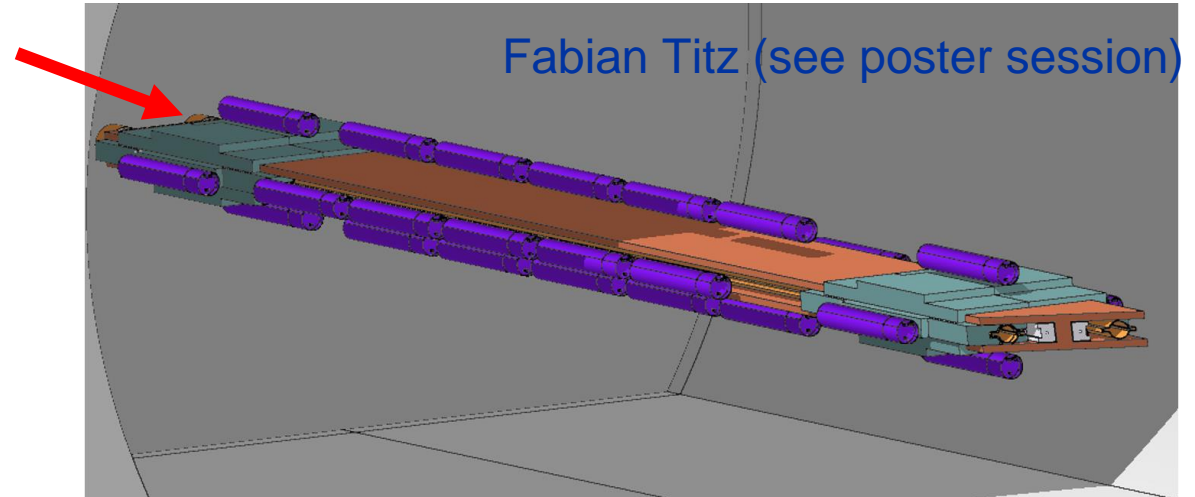

Beam
impact

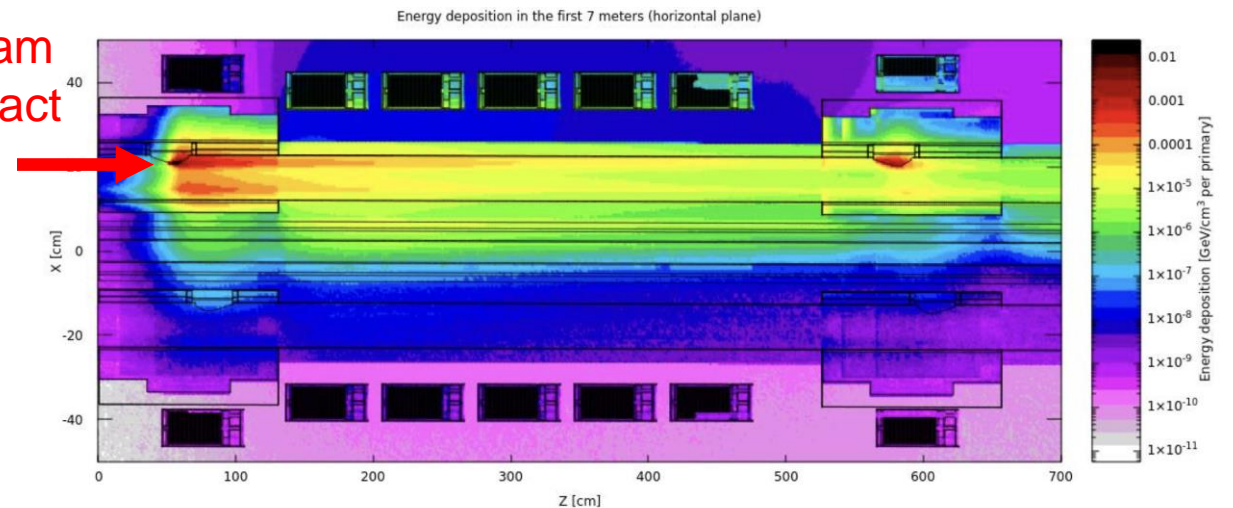

Simulations results

Expected energy deposition in each of the ionisation chambers per primary electron impacting on the SR absorber.

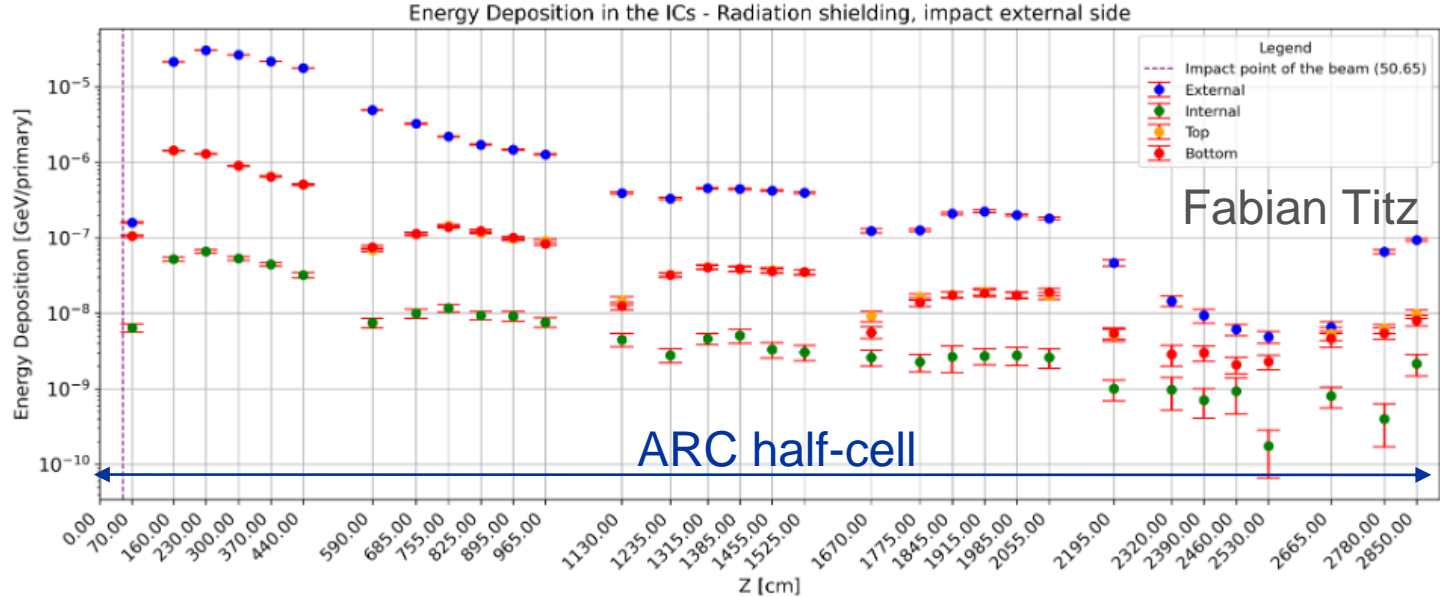

Expected BLM signal could be derived from this quantity.

Expected BLM signal comparable to LHC values.

Next steps include to convert the signal to expected current, assess the impact of the SR and beam gas interactions, study other detector responses and the combination of losses from different beams and rings.

	Energy	Bunch Intensity	Bunch fraction needed to melt copper	0.01 % detection	Number of particles 0.01% detection	10 x damage
HL-LHC	7 TeV	2.2x10 ¹¹ p	7%	0.0007%	1.54E+06	1.54E+11
FCC-ee (Z)	45.6 GeV	2.14x10¹¹ e⁻	50%	0.0050%	1.08E+07	1.08E+12
FCC-ee (W)	80 GeV	1.45x10 ¹¹ e ⁻	75%	0.0075%	1.08E+07	1.08E+12
FCC-ee (ZH)	120 GeV	1.32x10 ¹¹ e ⁻	30%	0.0030%	4.0E+06	4.0E+11
FCC-ee (ttbar)	182.5 GeV	1.64x10 ¹¹ e ⁻	28%	0.0028%	4.6E+07	4.6E+12

Summary

The FCC-ee beams have enough energy to damage machine components.

A Beam Loss System is proposed as part of the Machine Protection strategy at:

- Collider and Booster Ring
- Collimators and absorbers
- Injection and Extraction equipment

With this information estimated number of monitors has been proposed, together with cabling and electronics.

Specifications for the Beam Loss Systems are still to be defined but first studies and discussions on the Collider Ring expected beam losses have started.

Some challenges of the system:

- Synchrotron radiation:
 - to electronics
 - to detectors: signal to background levels
- Huge number of monitors: availability and reliability of the system, production, etc.
- Very small vertical beam size: hardware interlock BLM to trigger a beam dump on vertical losses.