



The FCCee-HTS4 project

M. Koratzinos

FCC week, Vienna

22/05/2025

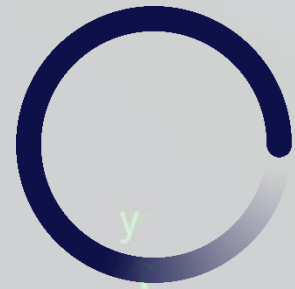

FUTURE
CIRCULAR
COLLIDER

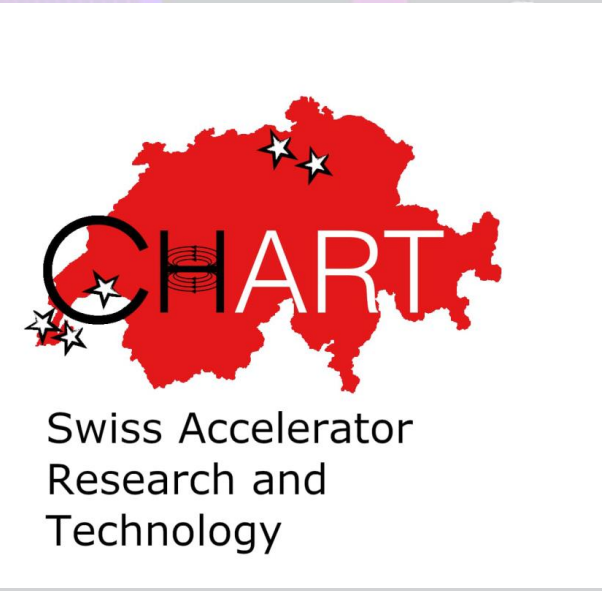

Swiss Accelerator
Research and
Technology

This work is performed under the auspices and with support from the Swiss Accelerator Research and Technology (CHART) program (www.chart.ch).

Aim of this presentation and contents

- HTS4 is a new project within FCC that aims at rather drastic changes to the baseline collider arc design.
- It has a number of important advantages, (and also a few challenges).
- It was not part of the feasibility study
- I will give you an update on all aspects of the project

Previously on HTS4

- Please see the HTS4 presentation during FCC week 2024:

[https://indico.cern.ch/event/1298458/contributions/5997286/attachments/2875198/5034971/HTS4 San Fransisco.pdf](https://indico.cern.ch/event/1298458/contributions/5997286/attachments/2875198/5034971/HTS4_San_Fransisco.pdf)

Why?

- FCC is the best accelerator on the market today by a large margin
- All innovation in FCC-ee is in pushing optics and, in general, machine parameters to their 21st-century limit and, therefore, delivers unprecedented luminosity for physics.
- However, it uses old (and trusted) technology from the 20th century without advancing it considerably.
- Wouldn't it be nice to also push technology to its 21st century limits in certain areas (as long as we do not pay more?)

Why? – sustainability

- FCC-ee is the most energy-efficient accelerator proposed (and the one with the smallest CO₂ footprint (see <https://link.springer.com/article/10.1140/epjp/s13360-022-03319-w>)
- This is an attempt to make FCC-ee even more *sustainable* and at the same time increase *performance* by looking at the **main magnet systems** of FCC-ee
- We re also looking into increasing the *relevance of FCC to society* by adopting state-of-the-art technologies and trying to play a leading role in our respective fields

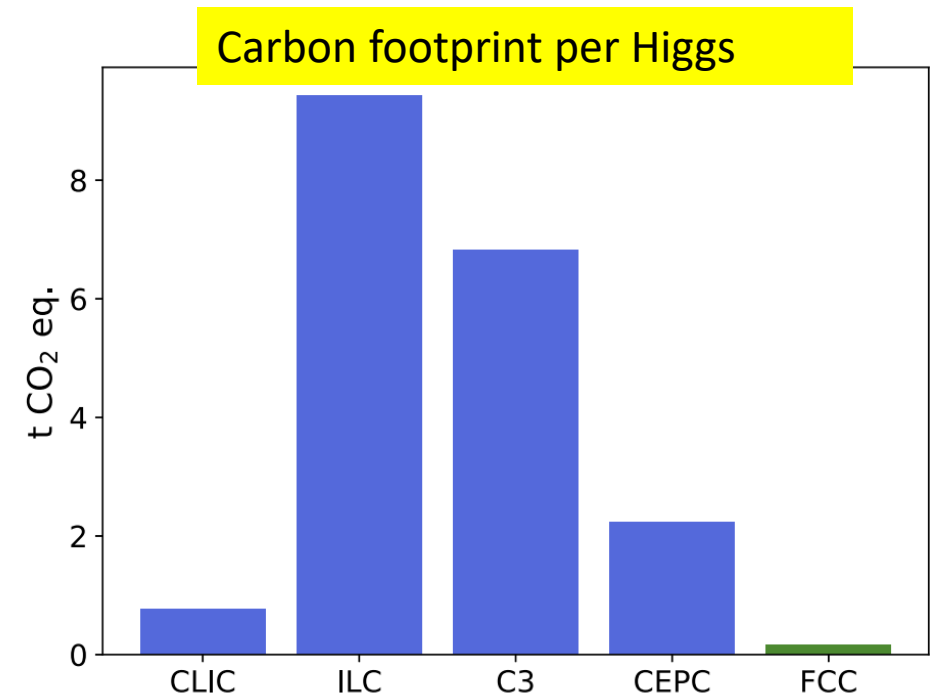
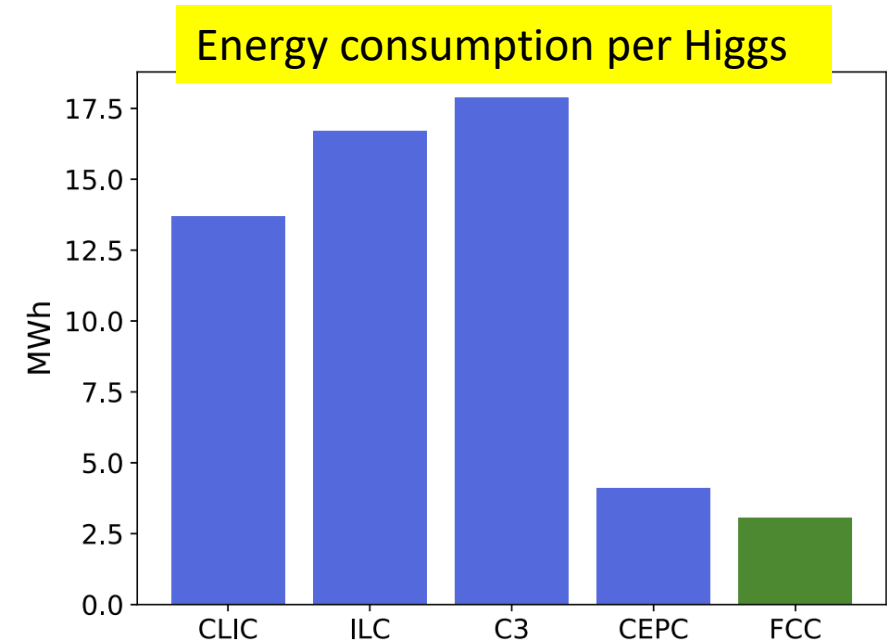

Power consumption – collider main magnet systems

We pay twice for normal conducting magnets: one through ohmic losses, and again for removing the heat with our cooling and ventilation (CV) system.

- At top energy, ohmic losses are 89MW (2023) for the main arc magnet systems.
- The power share of CV is another ~14MW
- Total is **~100MW**
- Contribution of quads and sextupoles dominate this power (~80%)
- **A high temperature superconducting magnet system is projected to have a consumption of only ~10% of that**

J.-P. Burnet, J. Bauche, for GHC

| Storage Ring | Z | W | H | TT |
|-------------------------|------|------|------|-------|
| Beam Energy (GeV) | 45.6 | 80 | 120 | 182.5 |
| Magnet current | 25% | 44% | 66% | 100% |
| Power ratio | 6% | 19% | 43% | 100% |
| Dipoles (MW) | 0.8 | 2.6 | 5.8 | 13.3 |
| Quadrupoles (MW) | 1.4 | 4.3 | 9.8 | 22.6 |
| Sextupoles (MW) | 1.3 | 3.9 | 8.9 | 20.5 |
| Power cables (MW) | 1.2 | 3.8 | 8.6 | 20 |
| Total magnet losses | 4.8 | 14.7 | 33.0 | 76.4 |
| Power demand (MW) | 5.6 | 17.2 | 38.6 | 89 |
| Cooling and ventilation | Z | W | H | TT |
| Beam energy (GeV) | 45.6 | 80 | 120 | 182.5 |
| Pcv (MW) | all | 33 | 34 | 40.2 |

A possibility emerges...

- Replace all arc quadrupoles and sextupoles, which in the baseline design are warm, with superconducting ones using HTS technology.
- Immediate advantages:
 - Quads and sextupoles can be **nested**, resulting in an **increased packing factor**
 - **Ohmic losses are zero** and replaced by cryo system power consumption
 - Correctors will also be nested
 - A much lighter system (smaller girder, etc.)
 - Higher luminosity
 - Less RF gradient at top energy
 - No need for a series of other compromises
- All the above is investigated by the HTS4 project

The HTS4 project

- Financed under the auspices of CHART
- Started September 2022 for three years
- Collaboration between PSI and CERN
- HTS4 are:
 - K. Puthran
 - B. Auchmann
 - J. Kosse
 - J. Schmidt
 - A. Habsburg
 - F. Bardi
 - I. Dimoulios
 - M.K.
 - Old members: A. Thabuis, V. Batsari, O. Kuhlmann, N. Nikolopoulos, C. Ormond



Swiss Accelerator
Research and
Technology

SSS main parameters

The latest optics design layout has the following specifications:

- Length of quads is **2.9m**. Quads **should not be shorter**, due to SR issues
- Strength of quads is **12T/m** at tt
- Length of sextupoles is 1.5m. Sextupoles can be made stronger and shorter at will.
- Strength of sextupoles is **812 T/m²** at tt.
- Together with necessary gaps and with all services, the length of the SSS will be **3.5m**

Improvement in packing factor

CDR and FS

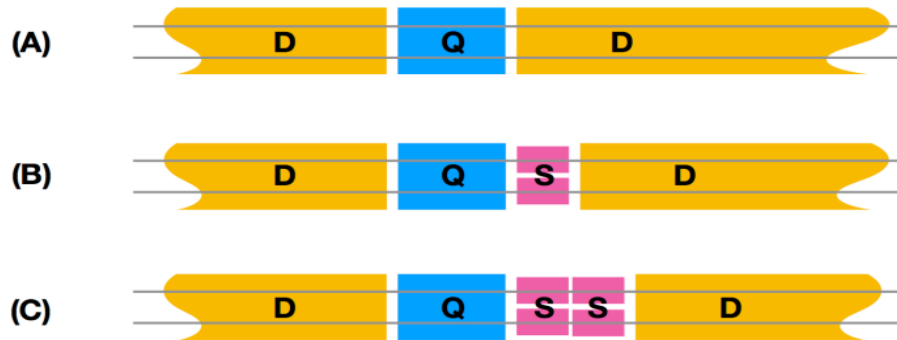

This proposal

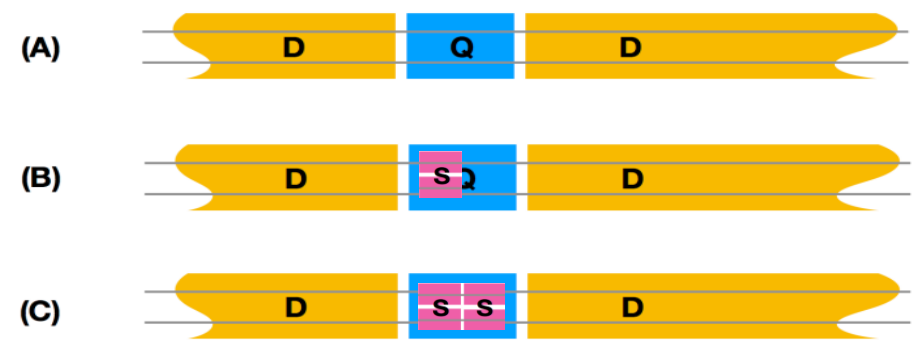

Half cell length: 27.9 m

- Three families of dipoles
- By nesting sextupoles and quads, only a single dipole size will be needed

**Increase in packing factor:
7%**

| Lengths (m) | | | No. units | Lengths (m) | | |
|-------------------------------|------|------|-----------|--------------------------------|------|------|
| CDR | | | | This proposal | | |
| Dipole | quad | sext | units | dipole | quad | sext |
| 21.2 | 3.2 | 3.2 | 1152 | 24.4 | 3.2 | - |
| 22.7 | 3.2 | 1.5 | 492 | 24.4 | 3.2 | - |
| 24.4 | 3.2 | 0 | 1256 | 24.4 | 3.2 | - |
| Tot. dipole length: 66237m | | | | Total dipole length: 70760m | | |

What does increasing the packing factor mean

Increasing the packing factor by 7% means:

- 7% increase in luminosity → a 14-year physics programme can be done in 13 years. Economies: 1 year of operation (\$\$\$\$)

AND

- 7% less RF cavities at the top energy. Economies: \$\$\$\$\$

QF/QF vs QF/QD

- Both optics designs (LCC and GHC) prefer to have QF/QF quads
- The warm magnets have a smaller power consumption if operated in QF/QD geometry
- LCC optics: the QF and QD magnets have different lengths:
 - QF: 2.39m
 - QD: 1.86m

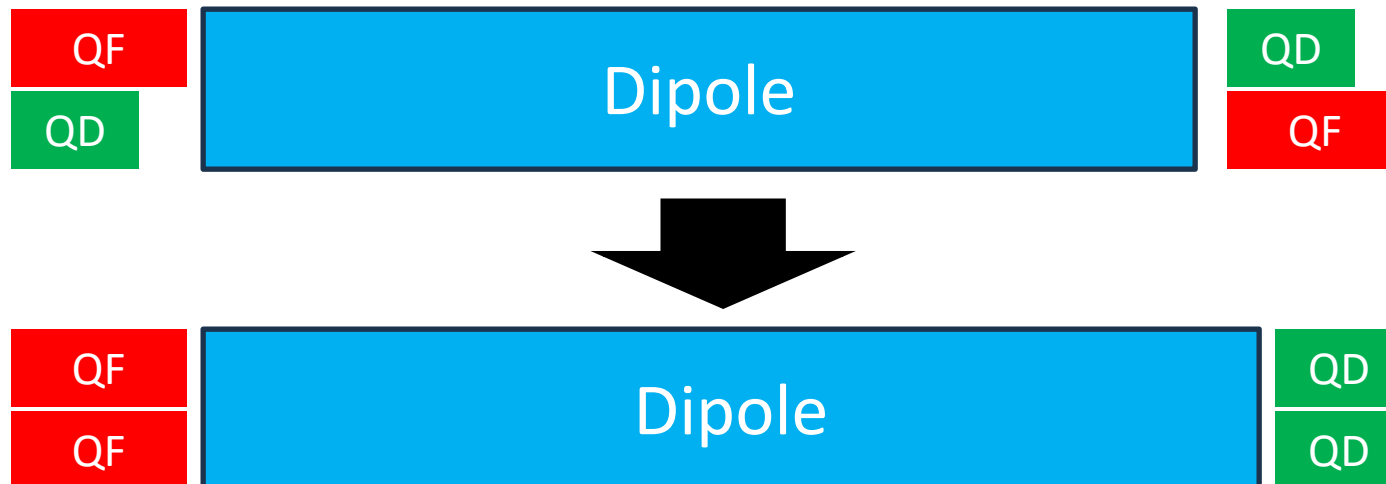

Tripple nesting

- There has been a lot of work recently (at EPFL) trying to include a dipole component in the SSS. See for instance https://indico.cern.ch/event/1408515/contributions/6515072/attachments/3071073/5433047/FCCWEEK2025_final.pdf in this conference.
- Potential increase in luminosity: 16%
- Potential decrease in RF cavities at the top: 16%
- Work is ongoing.
- We can accommodate a third layer of nesting at HTS4 with little effort.

Other advantages

- No magnetic axis shift in the quads (magnets are independent units)
- Alignment is easier – a quad-sextupole unit is aligned at the factory
- Weight of the system is much reduced – no heavy girder (our estimate: 10,000kg to 1,600kg)

Cooling scheme: central v distributed

We are investigating two schemes:

- Distributed system, with cryocoolers on every SSS cryostat (2 or 3 cryocoolers per cryostat for redundancy and large MTBF)
- A centralized system with a helium distribution line and individual (passive) cooling lines for each SSS, based either on Hydrogen or Neon
- Both schemes have been investigated, the centralized scheme conceptual design study by external consultant

Distributed Cooling

- Individual conduction cooling, using commercially available cryocoolers
 - Need to have adequate mean-time-between-failures
 - Need to consume as little as possible
 - Need to ensure operation in the harsh radiation environment of the tunnel
 - Are there any vibration issues?

Cryocooler example: a popular choice: SHI RD-125

RD-125D 77K Cryocooler Series

Performance Specifications

| Power Supply | 50Hz | 60 Hz |
|------------------------------------|---|-------|
| 1 st Stage Capacity | 30 W @ 77 K | |
| Minimum Temperature ¹ | <30 K | |
| Cooldown Time to 77 K ¹ | <25 Minutes | |
| Weight | 15.0 kg (33.1 lbs.) | |
| Dimensions (HxWxD) | 345 x 140 x 301 mm (13.6 x 5.5 x 11.9 in.) | |
| Maintenance | 10,000 Hours | |
| Regulatory Compliance | CE, UL, RoHS | |

Standard Scope of Supply

- RD-125D Cold Head
- CNA-11 Compressor
- Helium Gas Lines – 7 m (23 ft.)
- Cold Head Cable – 3-6 m (10-20 ft.)
- Power Cable – 5 m (16.5 ft.)
- Tool Kit

¹Lowest temperature and cooldown time are for reference only.



RD-125 Cooling capacity:

- 33W@77K,
- 12W@40K

Power consumption: 1.3kW,

Price today: 15.5k euros ready to cool

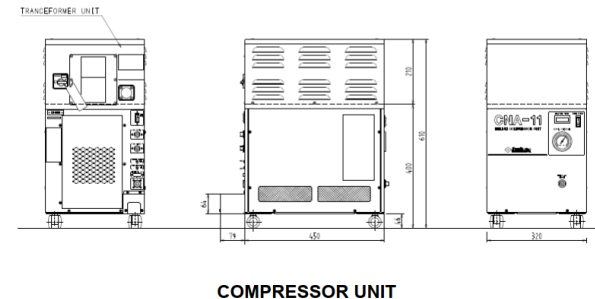

Size of unit is 320 X 450 X 610 mm

Power consumption of 2900 units:
4.1MW power or 20GWh per year

Distributed cryogenic cooling line + Centralized system

1) Main cooling loop with ~20 K GHe

+

2) Individual thermal siphon between main line and each magnet. Passive

Top view of tunnel

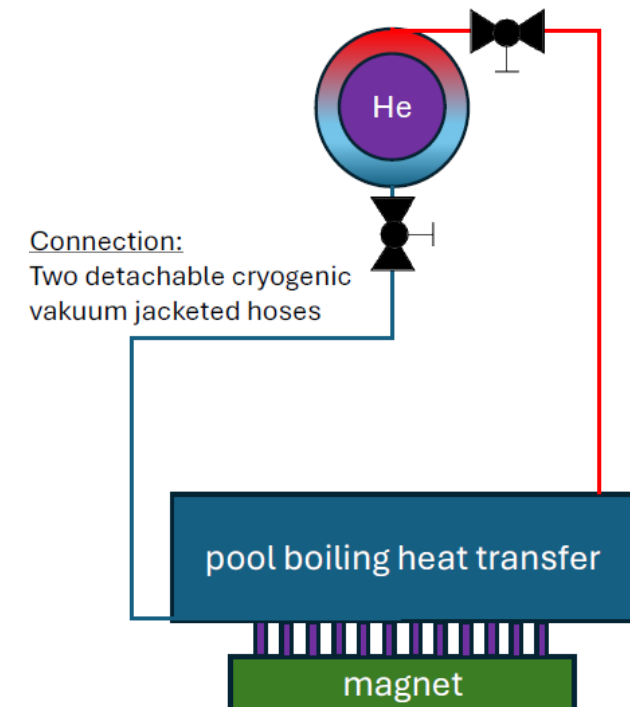
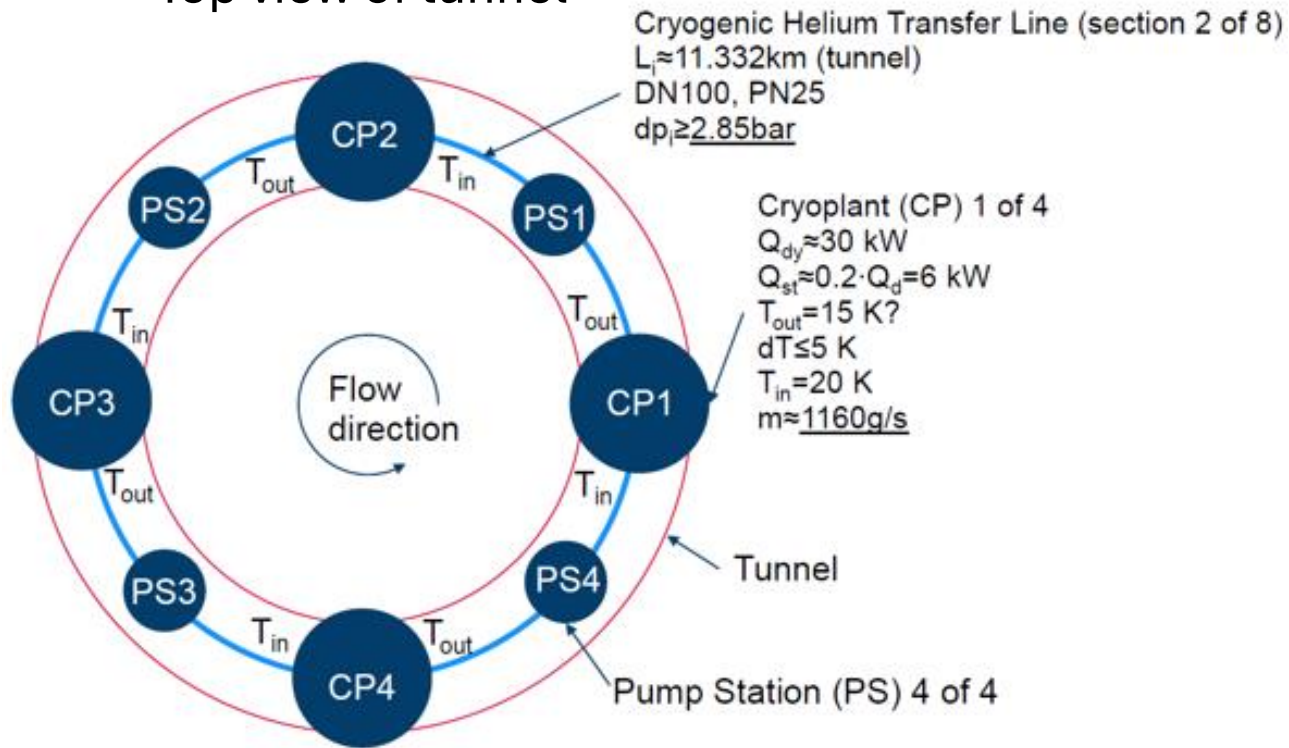

Conceptual design study by FZ Jülich (J. Bessler, E. Rosenthal) including in-depth dependability and cost study.

Distributed cryogenic cooling line

1) Main cooling loop with ~20 K GHe +

2) Individual thermal siphon between main line and each magnet. Passive

Initial calculations give confidence in this approach

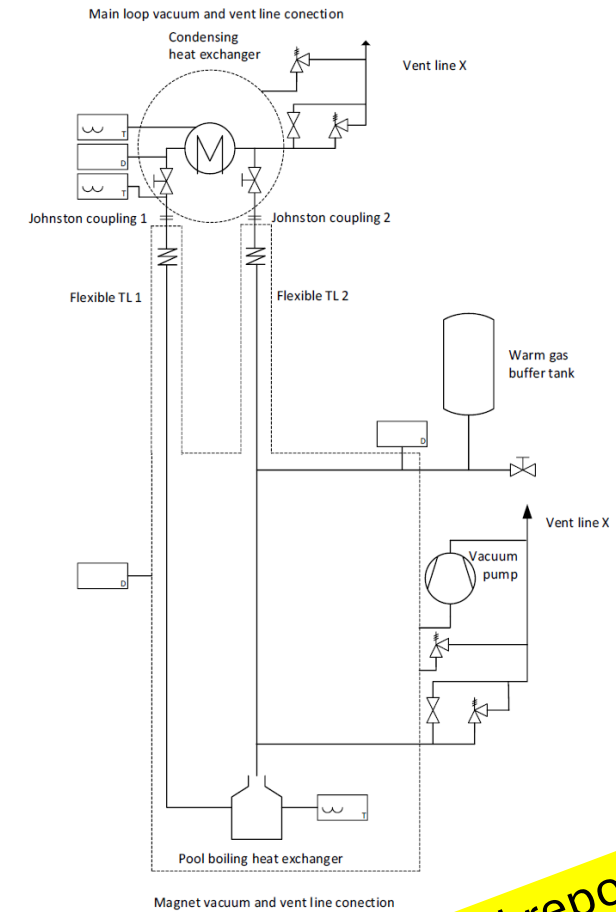
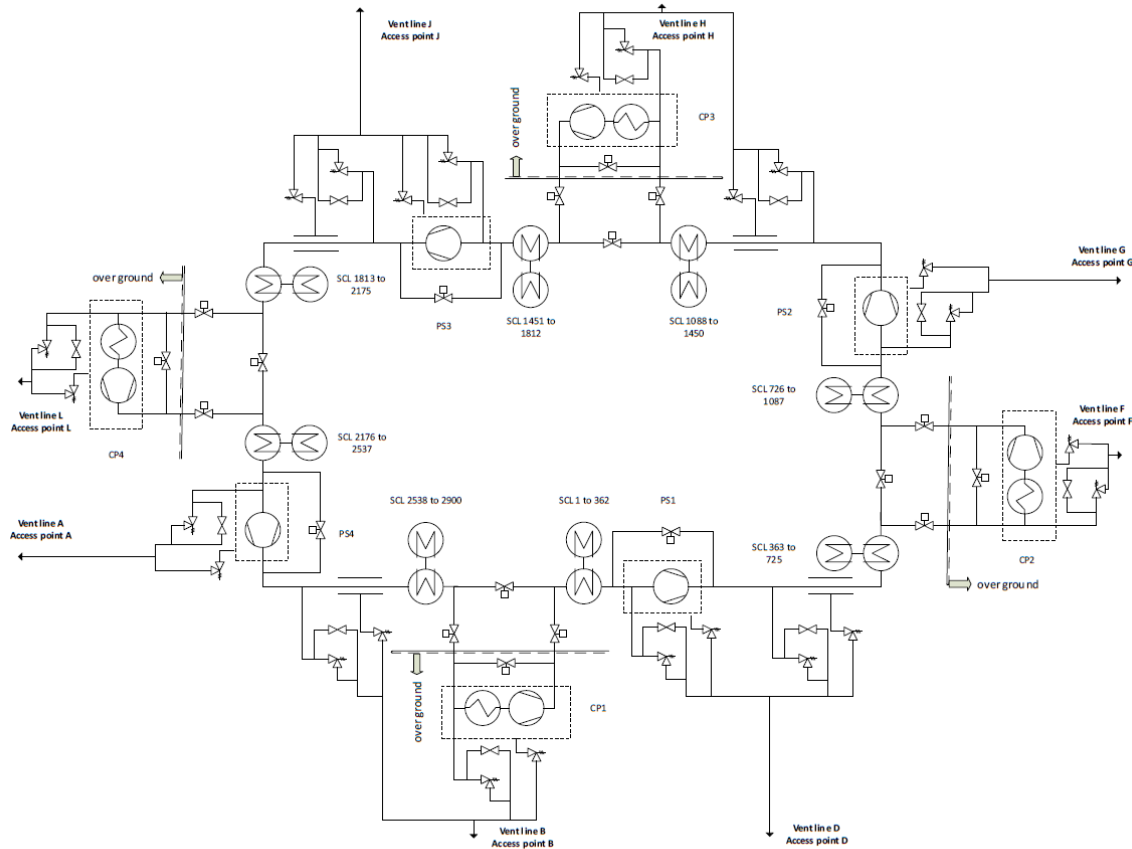

Conceptual design study by FZ Jülich (J. Bessler, E. Rosenthal)

Full report available

Demonstrators

- Since we are dealing with a new technology (quads and sextupoles using HTS conductor) one (or more) short-length demonstrators are needed to prove that our technology choices are correct.
- We are building **two sextupole demonstrators**:
 - CCT with insulated tapes
 - CT with partially insulated tapes

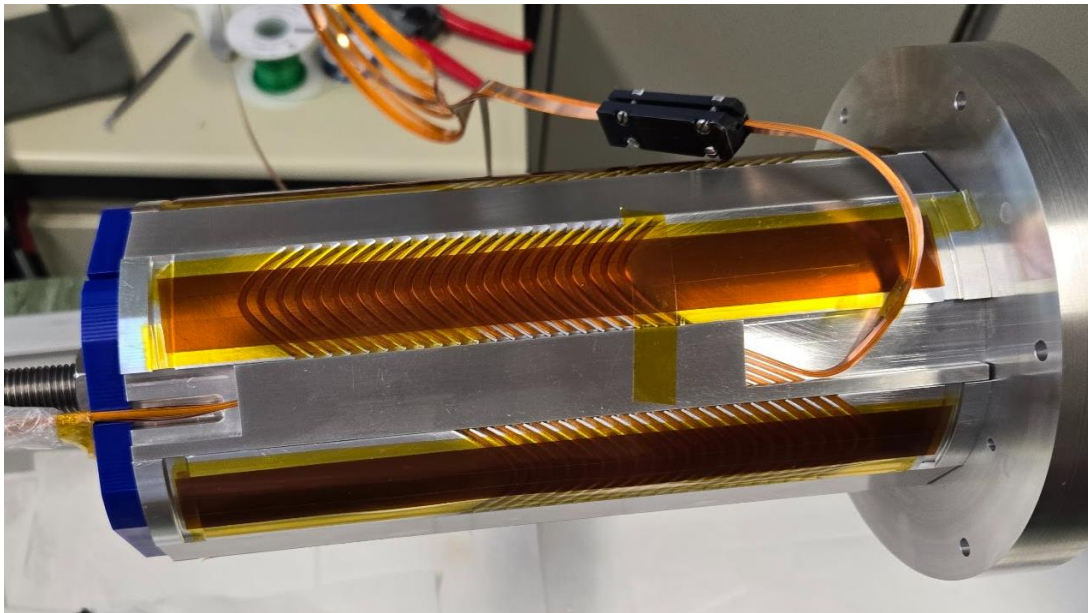

Cosine-theta option, demonstrator sextupole

Coil technology:

- HTS tape coated by **in-house** coating line
 - Tuned resistivity, minimal thickness (15 μm)
 - Coil curing at 170°C for handling and reproducibility

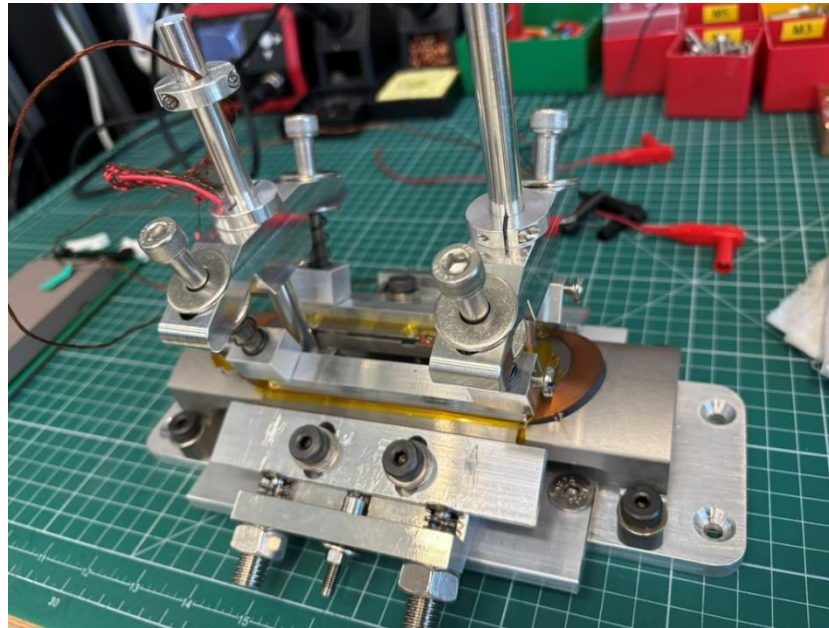
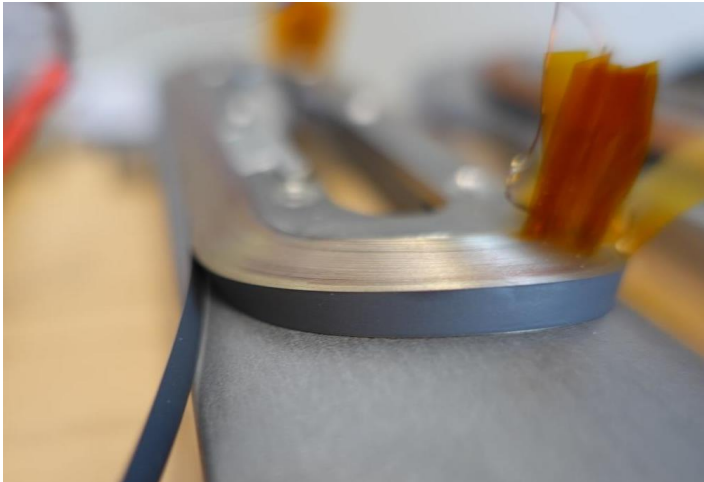

Cosine-theta option, demonstrator sextupole

Coil technology:

- HTS tape coated by **in-house** coating line
- **Automated coil winding**
 - First fully-automatic 4-axis cos-theta winding.
 - Requirement for cost reduction and reproducibility.



Cosine-theta option, demonstrator sextupole

Coil technology:

- HTS tape coated by **in-house** coating line
- **Automated coil winding**
- All coils have **reached I_c in LN2** without quenches.
- Assembly and impregnation of subscale sextupole next week.



Next steps

- Both demonstrators will be tested, but their short length does not permit accurate field measurements
- We will build a bigger nested (quad-sextupole) prototype – ready Q4 2025
- This prototype will be tested thoroughly
- We are especially interested in persistent current measurements
- This will be our proof of principle for the HTS nested system

Power converters

- Individual power supplies for every magnet is the most performant solution.
- No need for a quadrupole trim, for instance.
- Allows for all polarities
- (in any case, baseline optics has a large number of sextupole families)

Our sister project: FCCee-CPES

- The heat loss of a traditional system through the copper power supply leads follows the simple rule **$\sim 90\text{W/kA}$** for two leads.
- Four current leads @250A: **45W** (cryostat radiation and conduction losses: **$\sim 12\text{W}$**)
- **Can we move the power supply inside the cryostat?**

Traditional system:

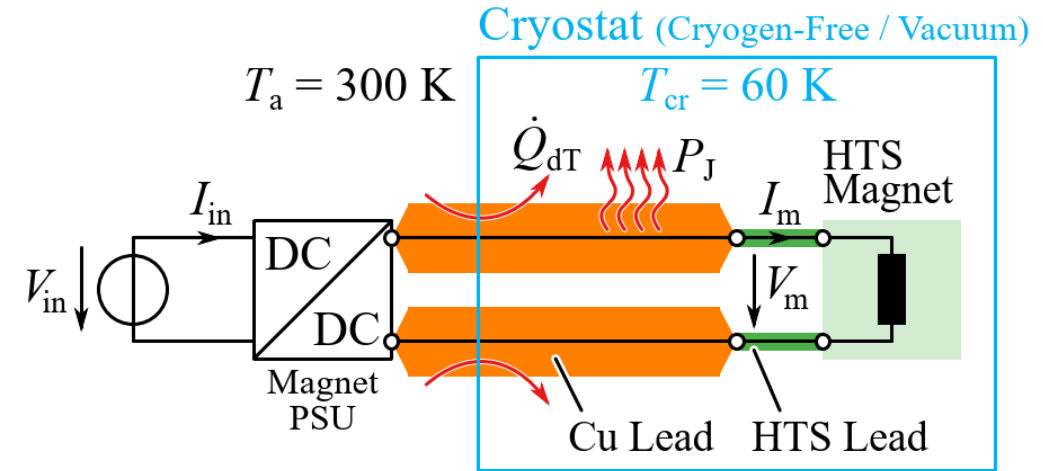

This proposal:

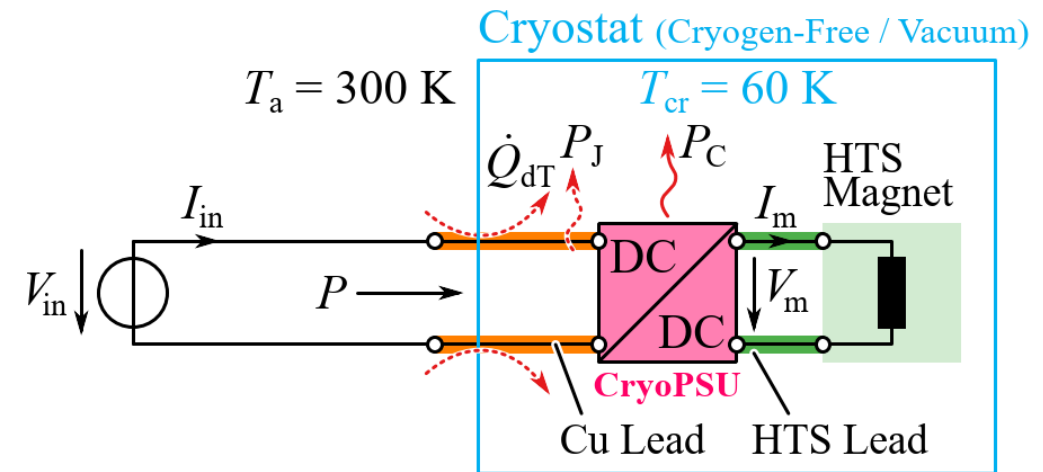

→ FCCee-CPES (PES, ETHZ) Jonas Huber, Danqing Cao, Daifei Zhang, Elias Bürgisser, Mücahid Akbas, Johann W. Kolar

CPES demonstrator

Full-bridge phase module losses measured in LN₂ @ 77 K

Modular system, can build redundancy for good availability

5-phase 100A demonstrator

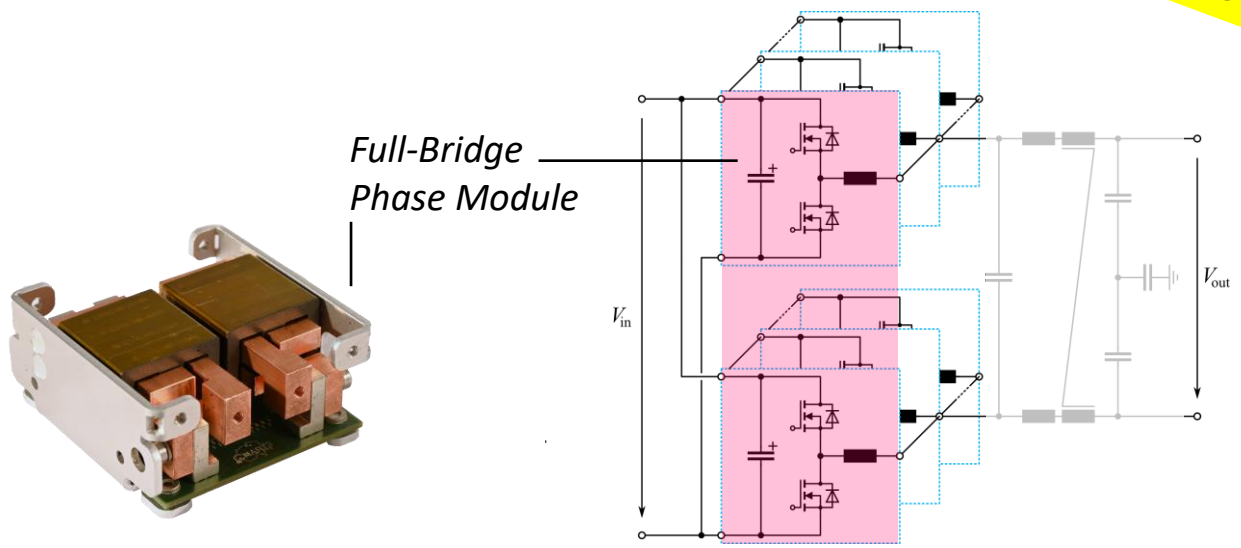

System uses Three-Switch T-Type (3S-TT) Phase Modules

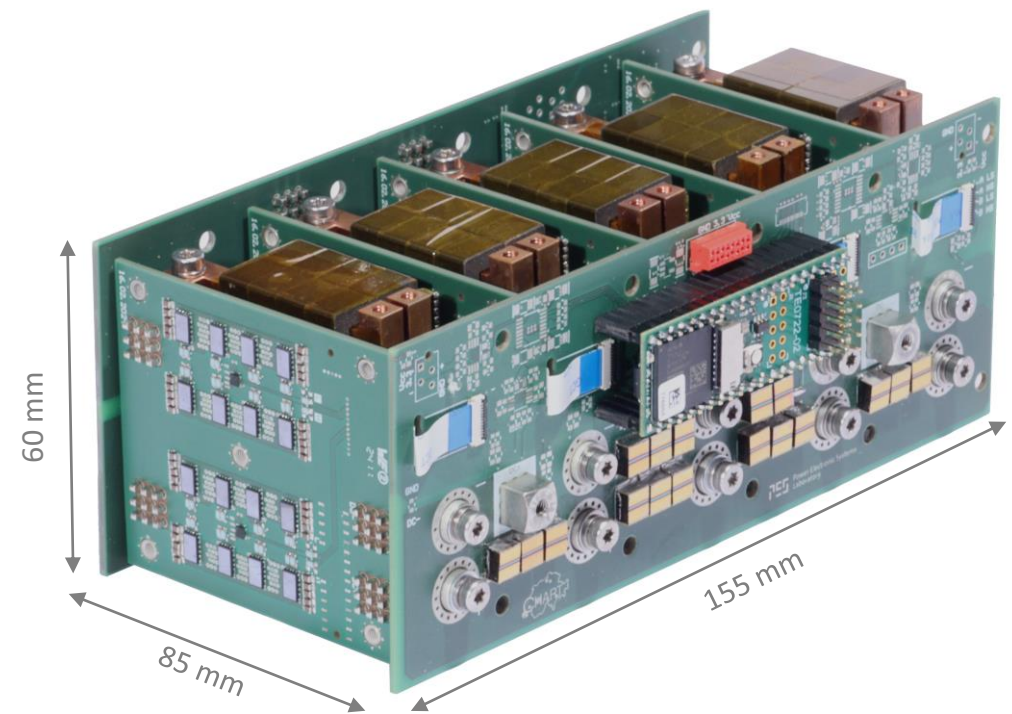

CPES – what was achieved

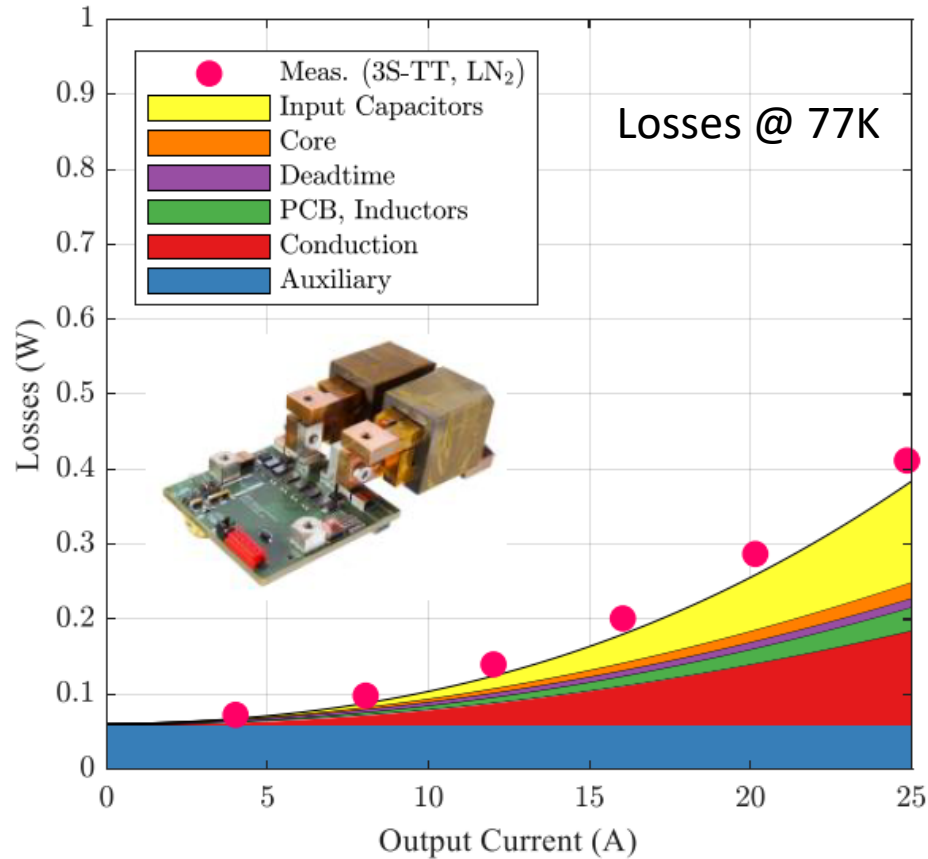

(a)

Measured power consumption of the prototype

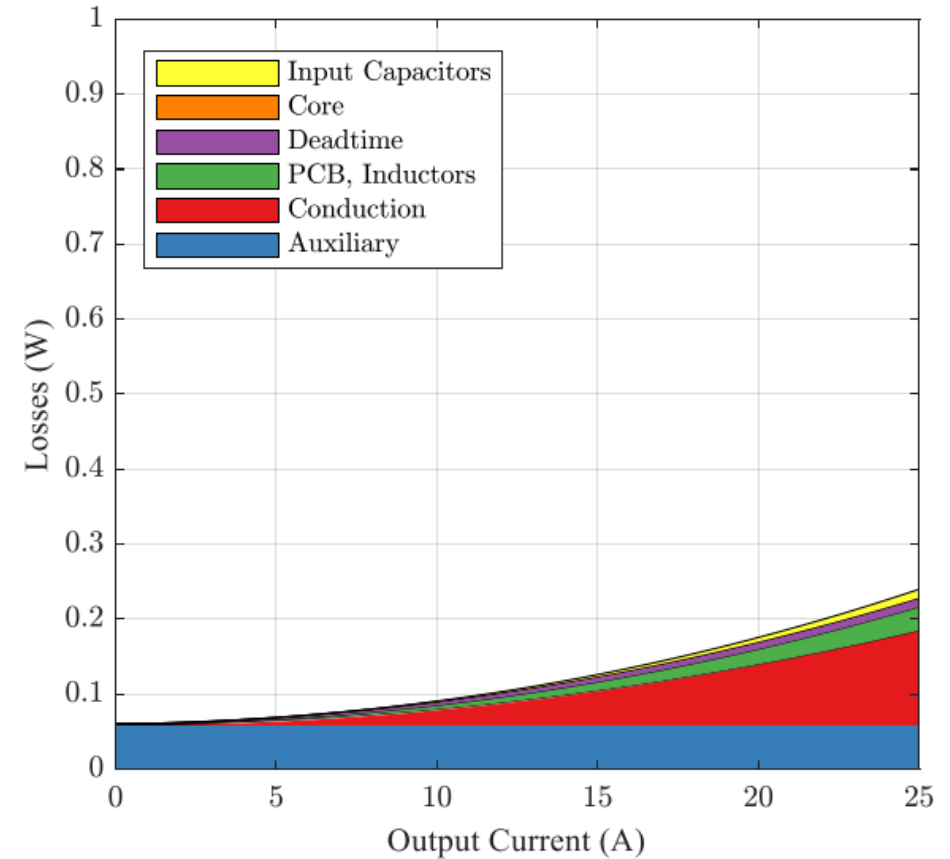

(b)

Extrapolated power consumption in FCC-ee conditions (load resistance 0.8mOhm)

Extrapolated power consumption: 3.0W for 250A and 20% redundancy (Conventional system: 22W)

FCCee-CPES summary

- For a traditional system with an external power supply, the losses for a 250A system would be 22W
- They have achieved 3W!
- We now need to try this idea in a realistic environment and gather experience regarding reliability, radiation tolerance, etc.

Conclusions

- The idea of cold Short Straight Sections has operational cost benefits, while increasing the performance and flexibility of the accelerator.
- The FCCee-HTS4 project aims at demonstrating that this idea is feasible.
- Our sister project FCCee-CPES goes a step further and reduces cooling costs by developing a power supply that will operate at cryogenic temperatures.
- These projects will increase the sustainability credentials of FCC-ee as well as increase performance.

THANK YOU

Extra slides

Collateral bonus

- We have a (parametric) design for an arc sextupole.
- This can easily be converted to a crab sextupole
- (Stack of 10 4mm tapes, current 770A, max. strength at the conductor of 4.3T.)

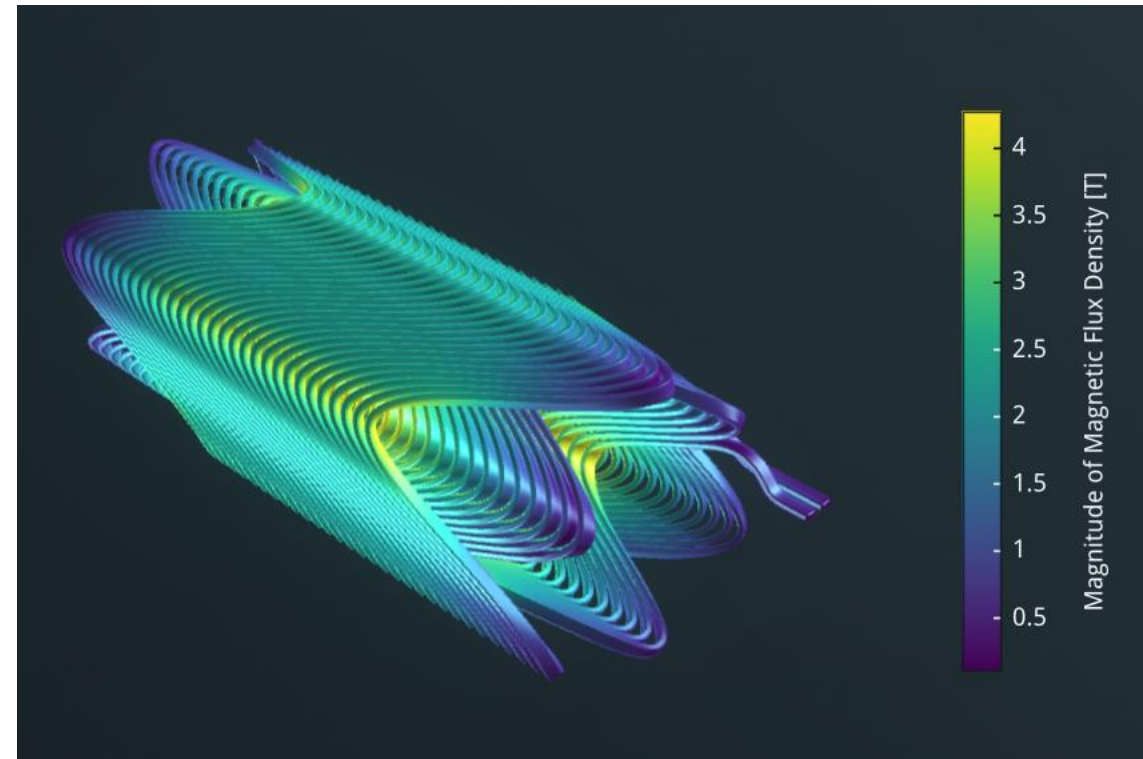

Crab sextupole specifications

| Sext | K2(m ⁻²) | Strength (T/m ²) | Length (mm) |
|------|----------------------|------------------------------|-------------|
| SY2L | 1.38335 | 3730 | 450 |
| SY1L | 1.75125 | 4730 | 450 |
| SY1R | -1.93369 | 5220 | 450 |
| SY2R | -1.56579 | 4240 | 450 |

- Design the sextupole for nominal strength of 5300T/m²
- Full (magnetic) length: 450mm
- Critical current fraction: 57% @20K

We have the ability to bring this demonstrator to completion within months

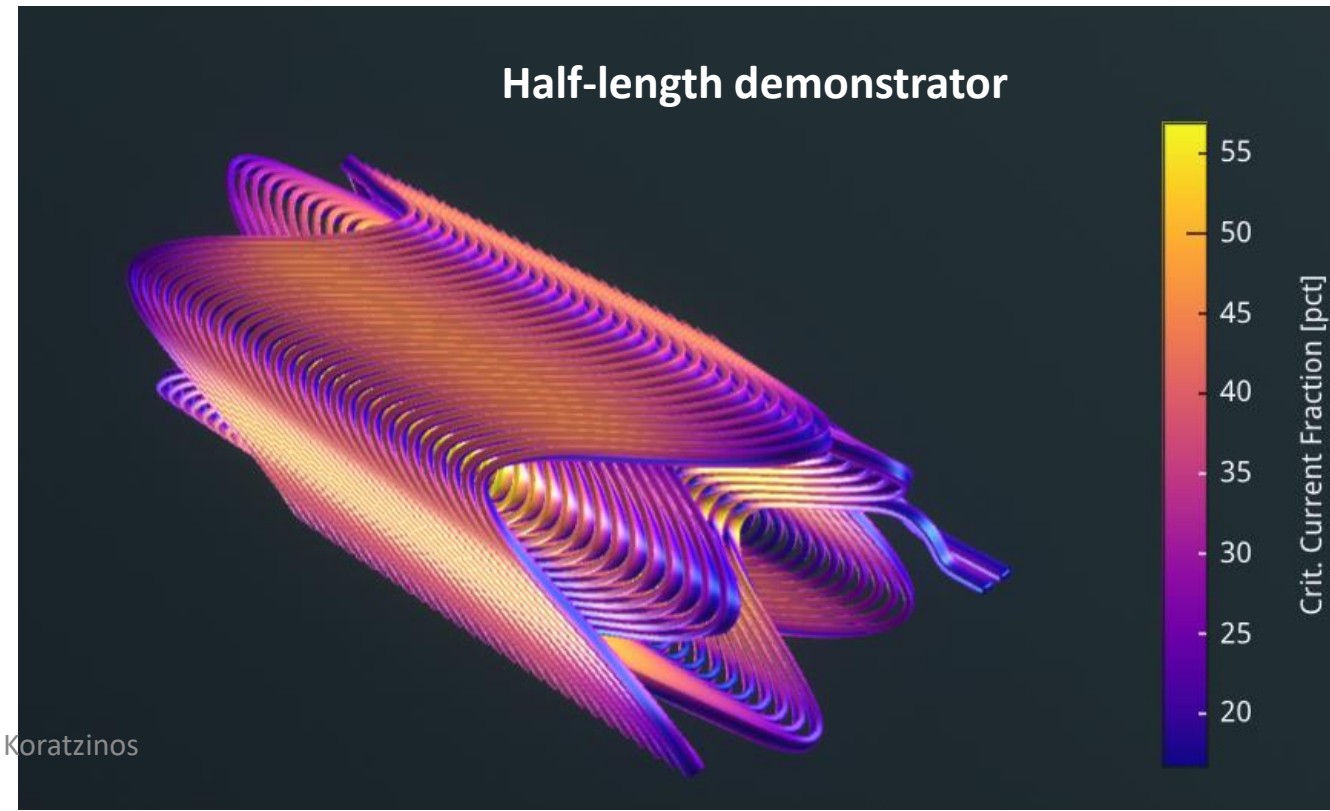

Choice of aperture

- Radius of beam pipe of the SSS should be such that photons from the last stopper do not touch it
- For a beam pipe diameter of 60mm, for a 4m length of SSS we need a minimum inner radius beampipe of 39mm
- This allows an aperture diameter of **84mm** for the SSS magnets
- Current design is **90mm**

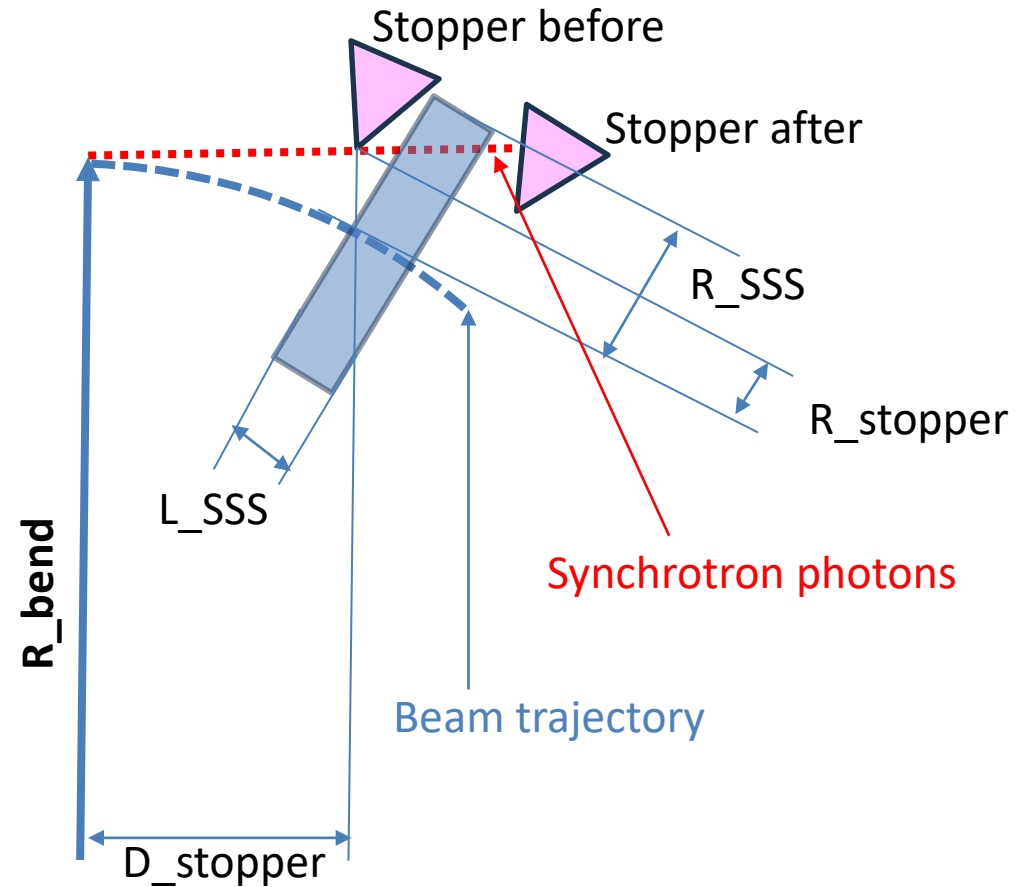

| R_{bend} (m) | beam pipe diam (m) | $R_{stopper}$ (m) | $D_{stopper}$ (m) | L_{SSS} (m) | R_{SSS} (m) |
|----------------|--------------------|-------------------|-------------------|---------------|---------------|
| 10021 | 0.070 | 0.034 | 26.485 | 4.0 | 0.045 |
| 10021 | 0.060 | 0.029 | 24.521 | 4.0 | 0.039 |

Cryostat assembly

Beampipe, photon stopper and absorber

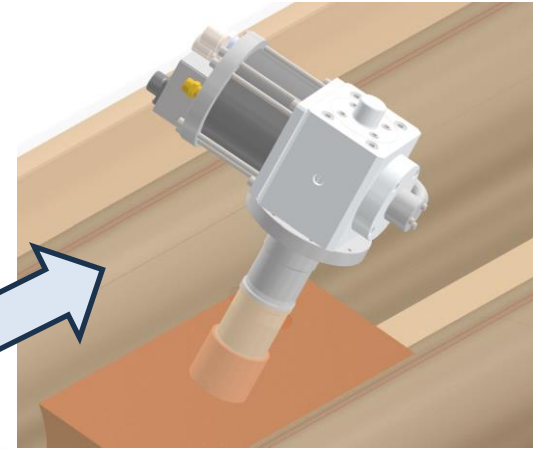
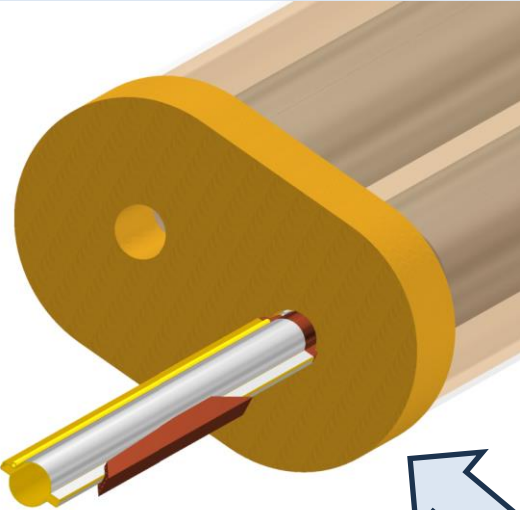

Cryocooler head

Total weight:
1560Kg

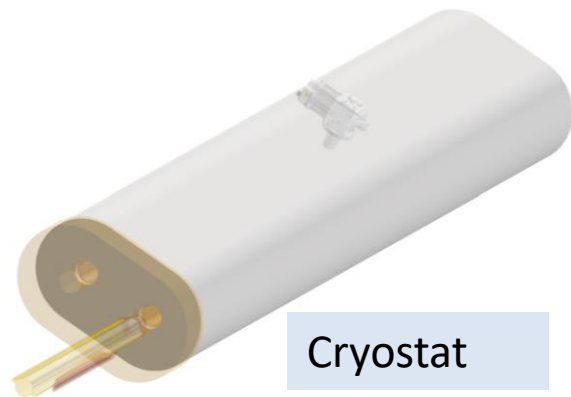

Cryostat

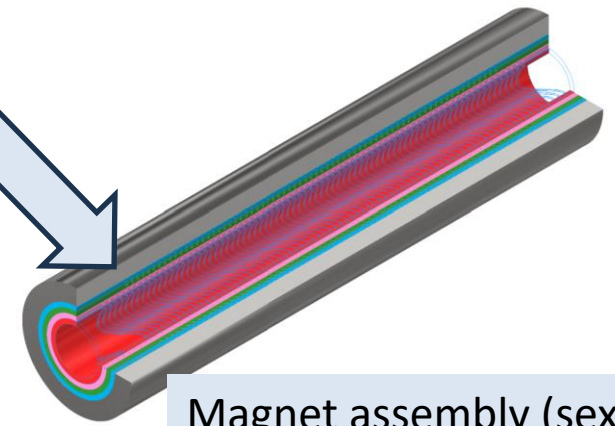
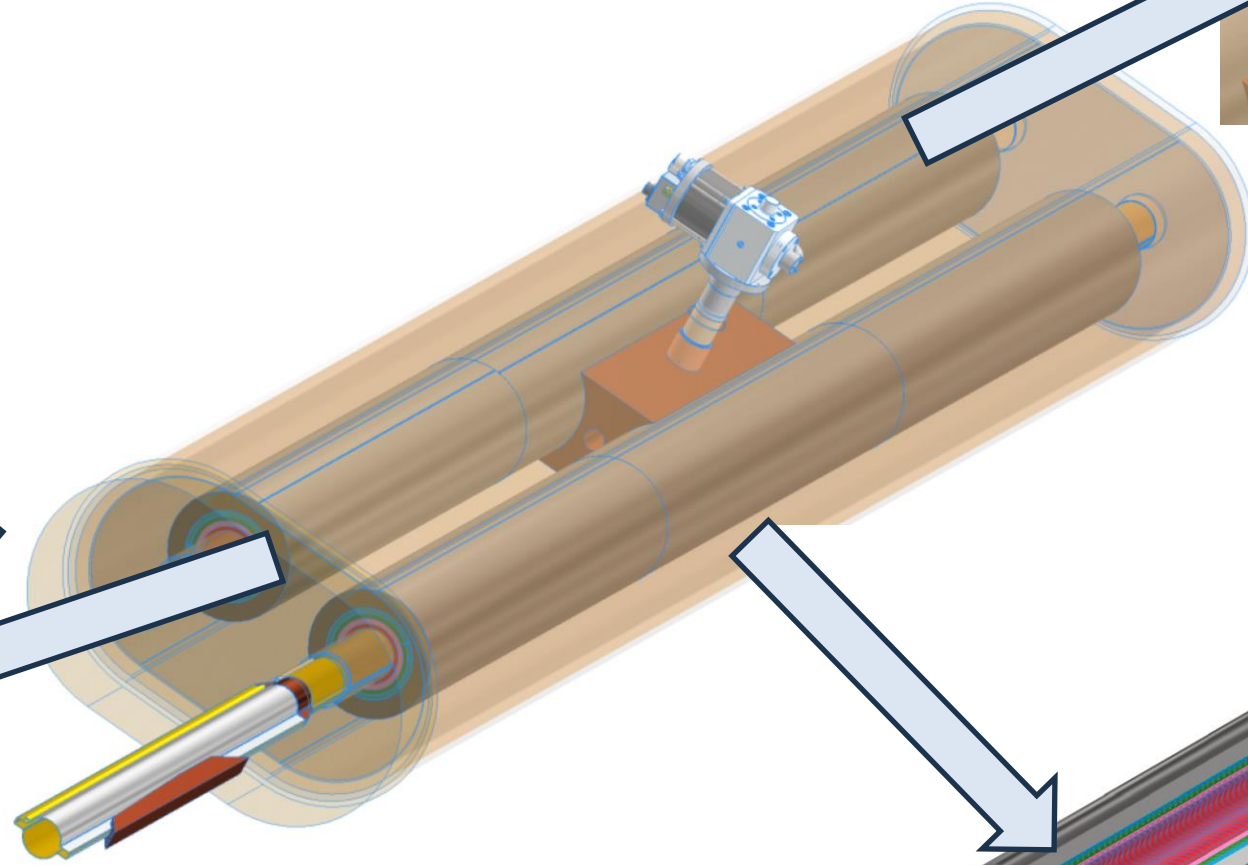

Magnet assembly (sext, quad, iron, 3 correctors) X3

The cryostat - losses

- Operating temperature of HTS: $\sim 40\text{K}$ (to be optimized)
- Operating temperature of power converters: $\sim 70\text{K}$ (to be determined)
- Estimation of losses (extrapolating from the LHC main dipoles): $\sim 11\text{W}$ (4W conduction, 7W radiation). To be verified
- Losses due to current leads or internal power supplies) – $\sim 12\text{W}$, see slides below

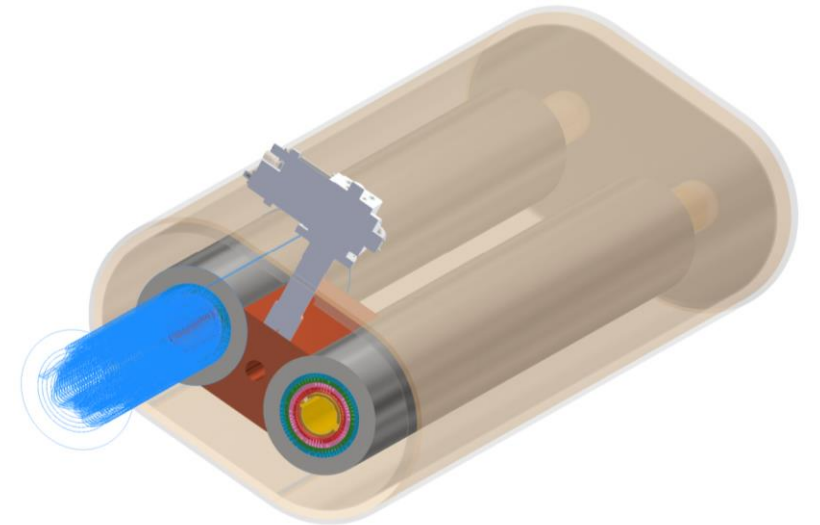
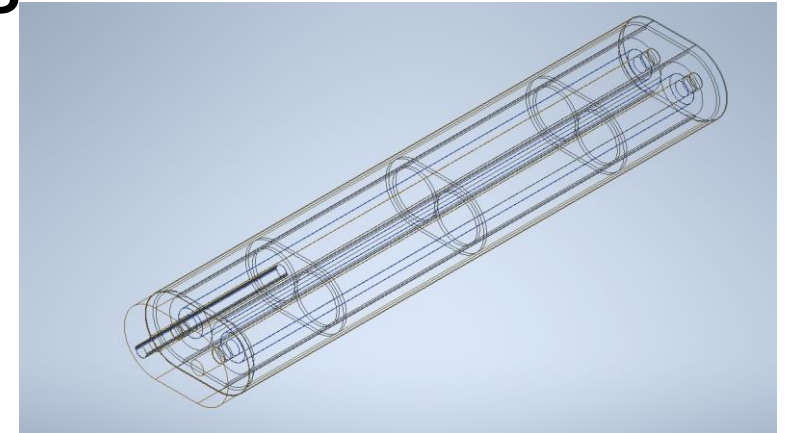

Inter-beam distance: 300mm (the old CDR value. New value: 350mm)

The girder and alignment

- For the CDR, the quad and sextupole magnets will be mounted on a girder (in yellow, below), alignment presumably done before transportation to the tunnel.
- Then the girder, as a whole, will be aligned in situ.
- In the case of HTS4, the weight of the SSS is substantially reduced
- Having a much lighter and nested (therefore shorter) system would **greatly reduce the cost of the girder and alignment uncertainties.**
- The girder will be a very simple object – an SSS cryostat mechanical support

Weight of baseline solution:

Quadrupole (2.9m): 4400+820Kg

Sextupole (1.4m): 880+150Kg

Total weight from **5220kg to 7280kg**

Weight of this solution:

Magnets+iron+cryostat: **~1600kg**

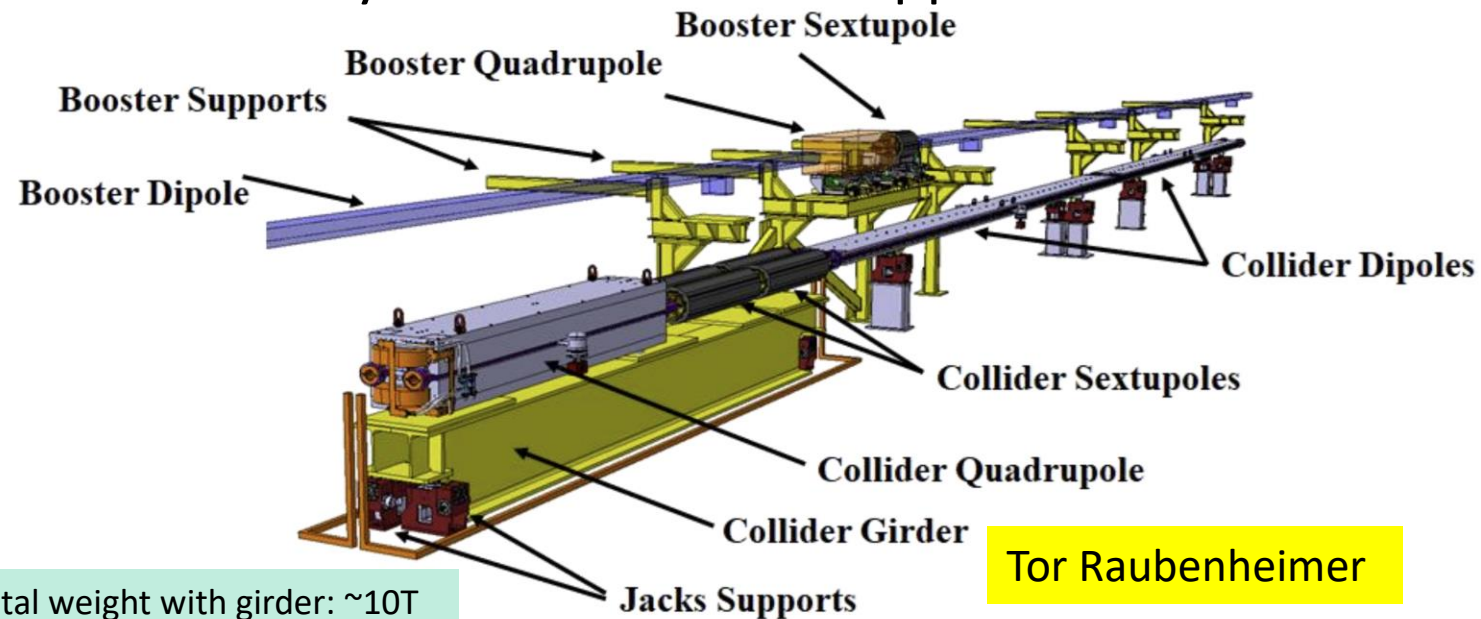



Manufacturing of
aluminium formers

Winding of HTS
tapes 7/6/2024



Winding pictures

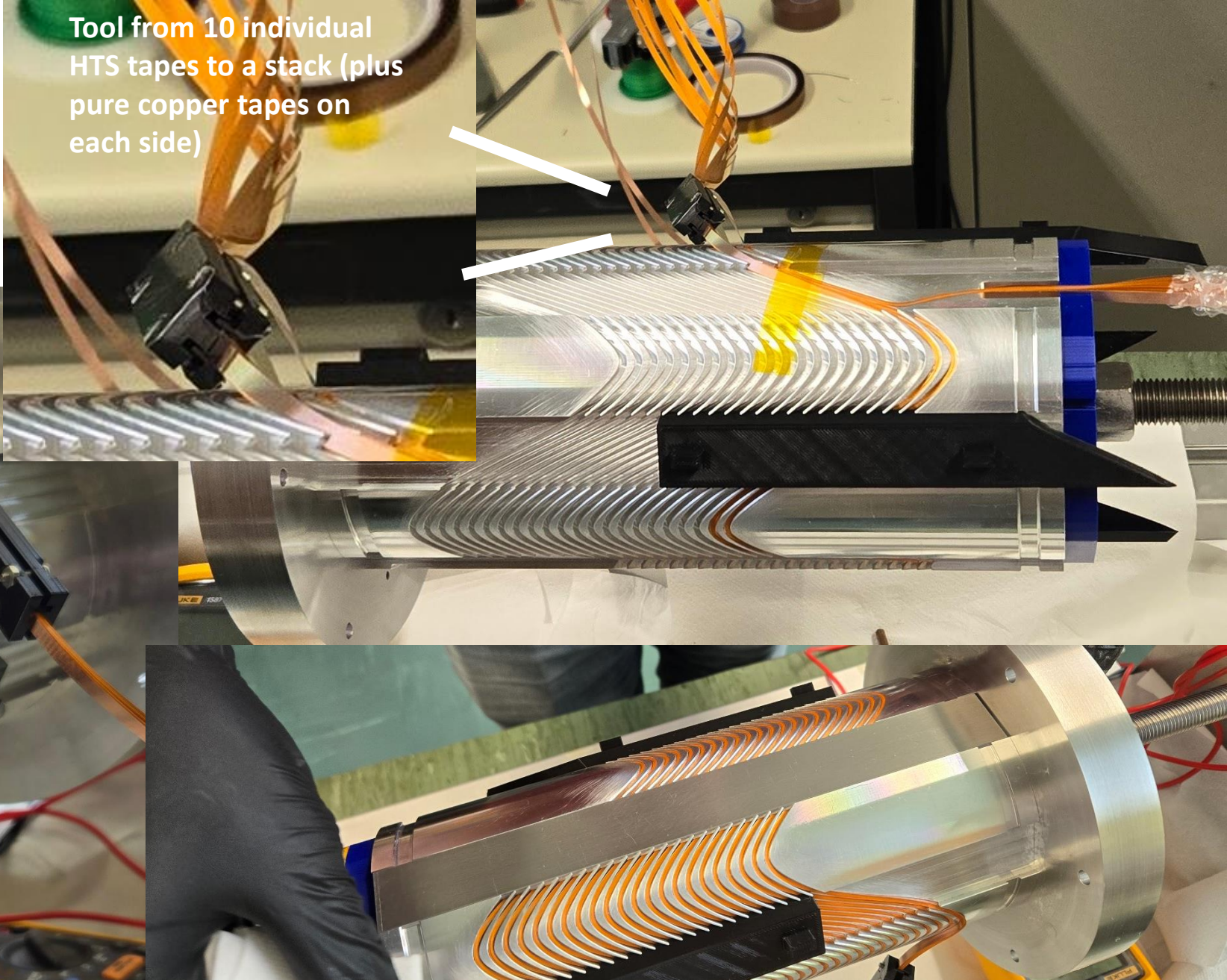

Finished first layer

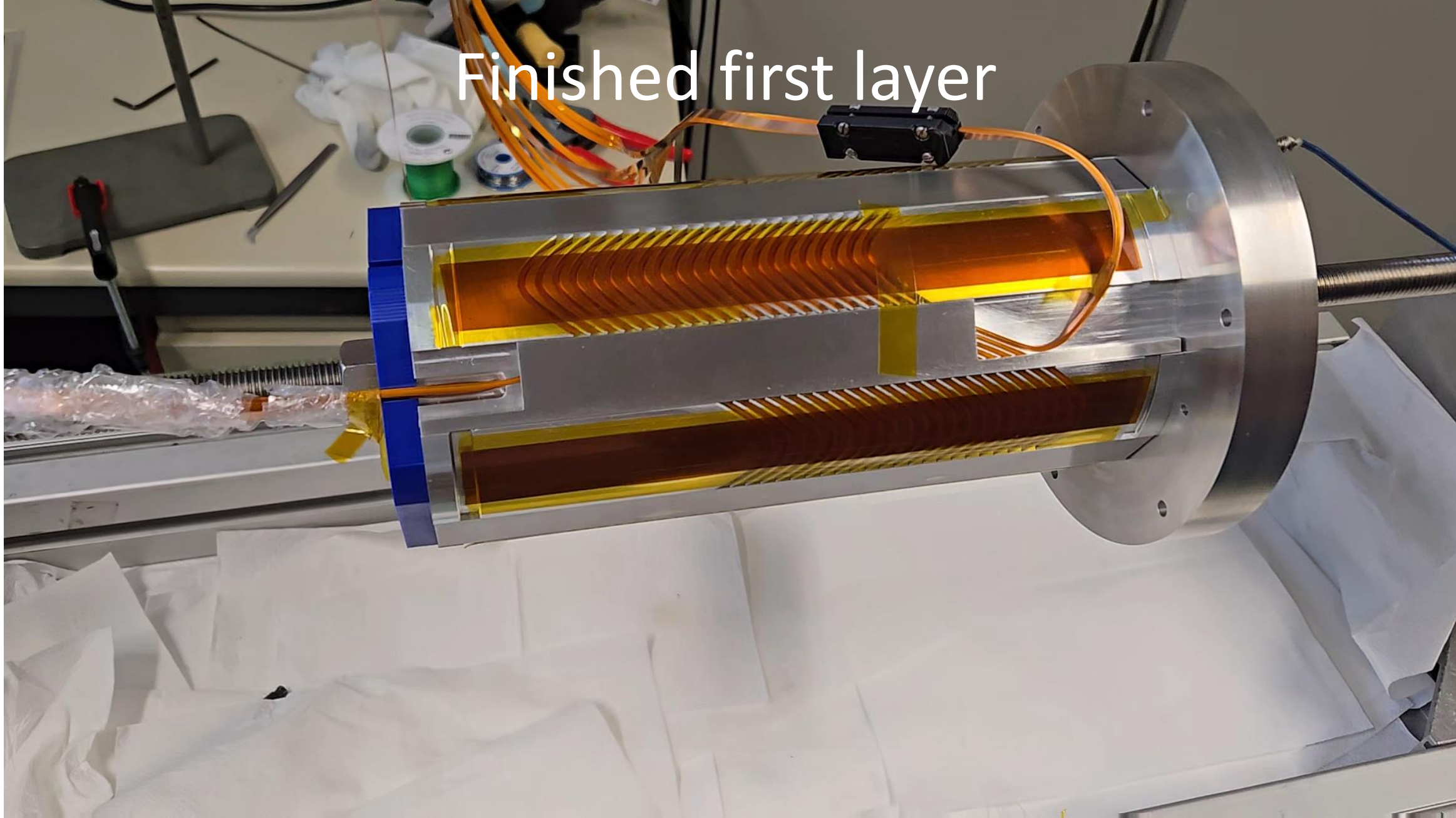

Reliability

Reliability engineering of cryocooler-based HTS magnets for FCC-ee

J. Kosse*, M. Koratzinos*[†], B. Auchmann*[†]

*Paul Scherrer Institute (PSI) Villigen, Villigen, 5232, Switzerland

[†]European Center for Nuclear Research, 01631 Geneva, Switzerland

- We are proposing a large, distributed, cryogenic system.
- Availability of such a system is paramount.
- (a centralized cryogenic system will also be considered)

TABLE III

HTS4 TOTAL SYSTEM AVAILABILITY FOR 1-YEAR OPERATING PERIOD, WITH n COOLERS PER SSS OF WHICH AT LEAST k NEED TO BE OPERATIONAL. COLORS INDICATE CONFIGURATIONS WITH HIGH (GREEN), QUESTIONABLE (ORANGE) AND LOW (RED) RELIABILITY. MTTF OF EACH COOLER IS 10^7 HOURS, AND MTTR IS 1 MONTH.

| | | Working coolers k | | | | | |
|-----------------------|---|---------------------|--------|--------|--------|--------|--------|
| | | 1 | 2 | 3 | 4 | 5 | 6 |
| Installed coolers n | 1 | 0.8335 | | | | | |
| | 2 | 0.9998 | 0.7145 | | | | |
| | 3 | 1.0000 | 0.9995 | 0.6253 | | | |
| | 4 | 1.0000 | 1.0000 | 0.9990 | 0.5558 | | |
| | 5 | 1.0000 | 1.0000 | 1.0000 | 0.9983 | 0.5003 | |
| | 6 | 1.0000 | 1.0000 | 1.0000 | 1.0000 | 0.9975 | 0.4548 |