



FCC-ee Power Coupler Design Overview

Shahnam Gorgi Zadeh

With inputs from: E. Montesinos, F. Peauger, R. Calaga, S. Jerome Calvo, C. Sharp, M. Timmins,
V. Parma. K. Canderan

Some cryomodule RF components

400 MHz cryomodule

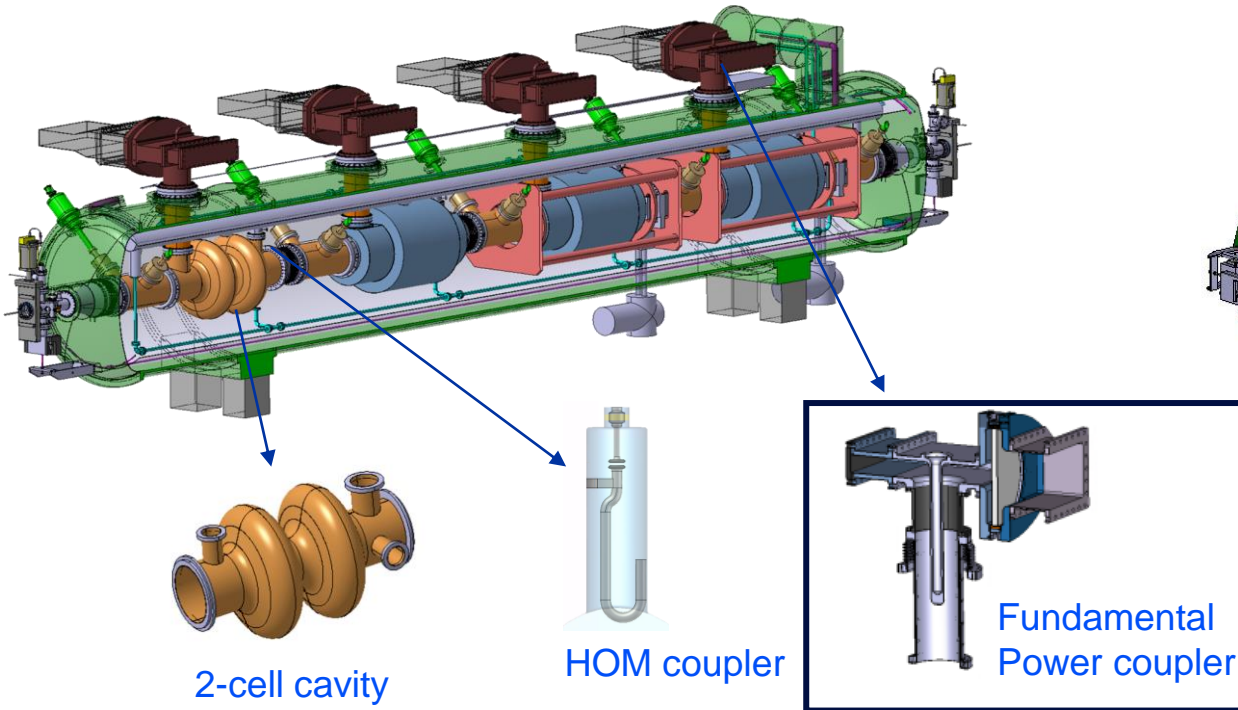

800 MHz cryomodule

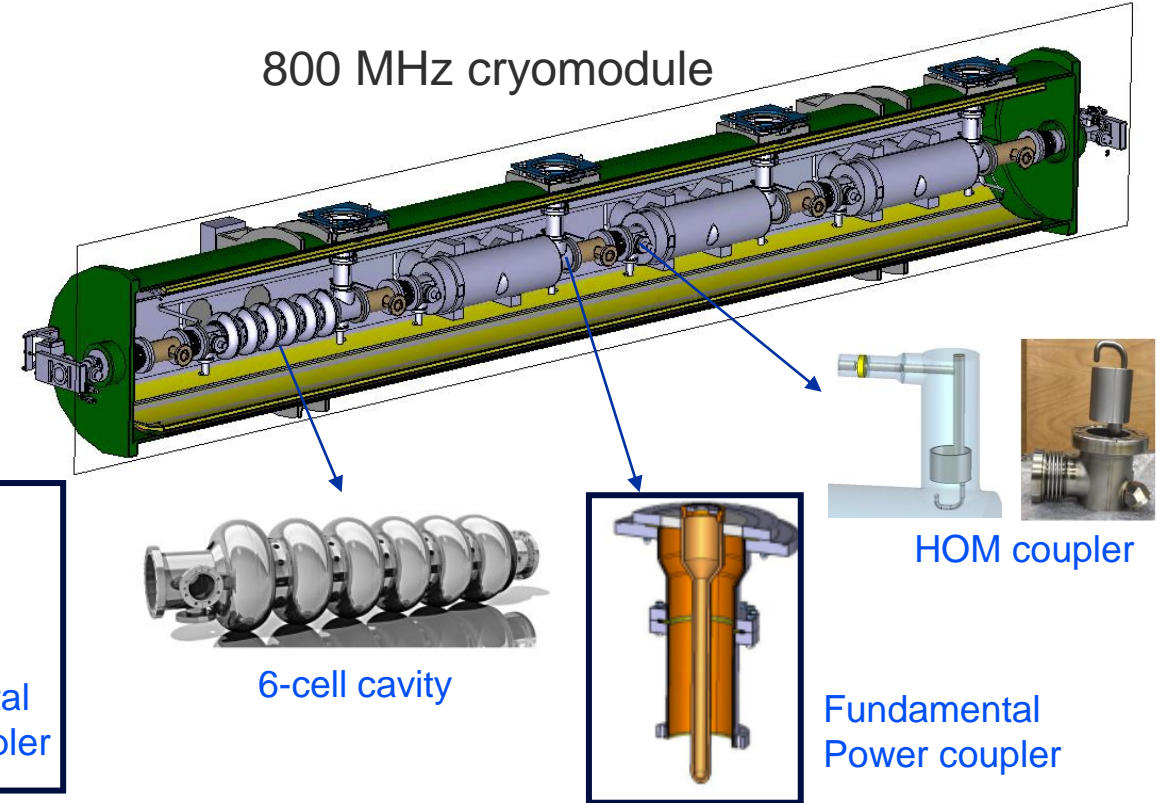

- Fundamental power coupler is a critical component that transfers high levels of RF power from the generator to the cavity and ultimately to the beam.
- Mainly RF aspects covered in this presentation.

FCC-ee power requirement

Input power necessary to establish V_{cav} in the cavity with a beam current I_0

$$P_{\text{in}} = \frac{V_{\text{cav}}^2}{4(R/Q_{\parallel,0})Q_{L,0}} \left(\left[1 + \frac{(R/Q_{\parallel,0})Q_{L,0}I_0}{V_{\text{cav}}} \cos \phi_s \right]^2 + \left[\frac{\Delta f}{f_{1/2}} + \frac{(R/Q_{\parallel,0})Q_{L,0}I_0}{V_{\text{cav}}} \sin \phi_s \right]^2 \right)$$

Make this term minimum by choosing optimum Q_L

Make this term zero by right detuning

$f = 400 \text{ MHz}$

$f = 800 \text{ MHz}$

$P_{\text{in}} = 380 \text{ kW to } 78 \text{ kW}$

$P_{\text{in}} = 195 \text{ kW to } 8 \text{ kW (or } 12 \text{ kW)}$

$Q_L = 9e5 \text{ to } 4.5e6$

$Q_L = 4e6 \text{ to } 1e8 \text{ (or } 2.7e7)$

$\Delta f \text{ from } -5.8 \text{ kHz to } -9 \text{ Hz}$

$\Delta f \text{ from } -734 \text{ Hz to } -2 \text{ Hz}$

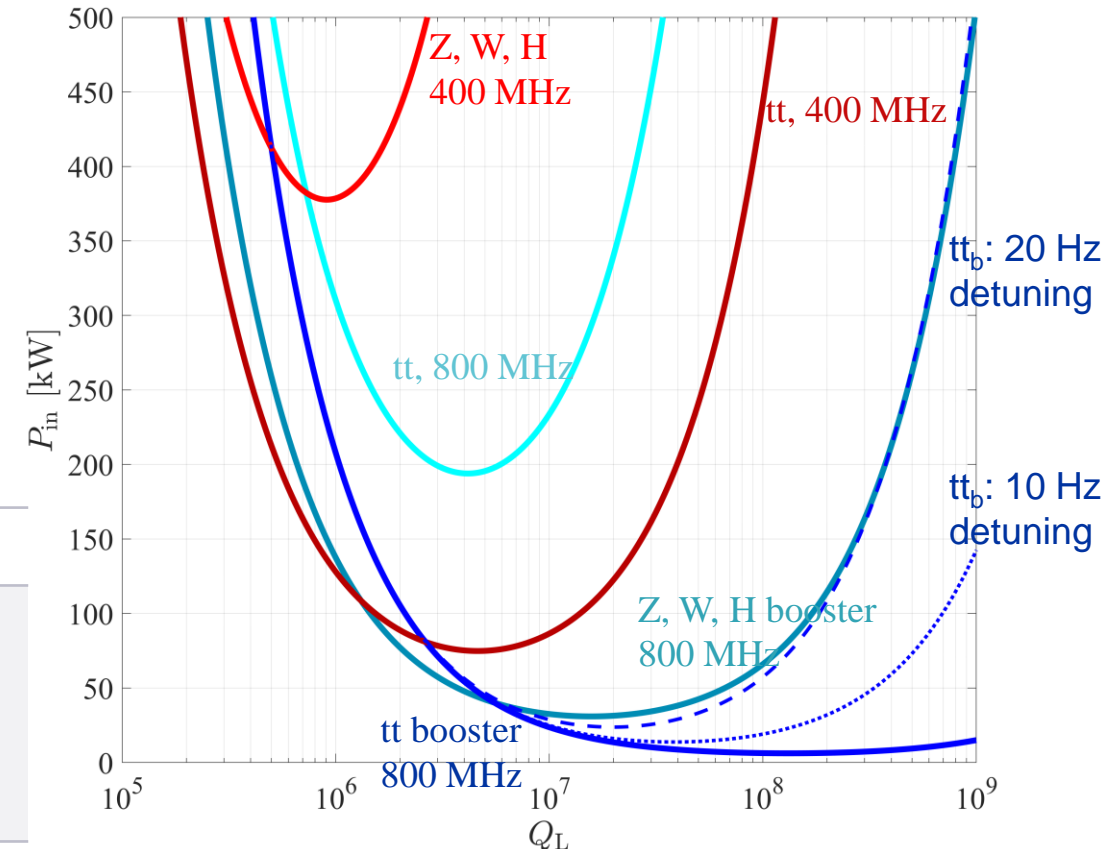

Peak field in coaxial lines

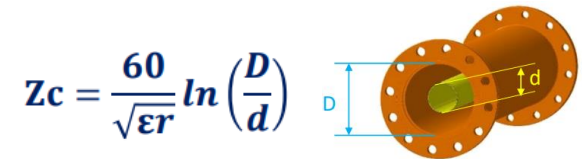
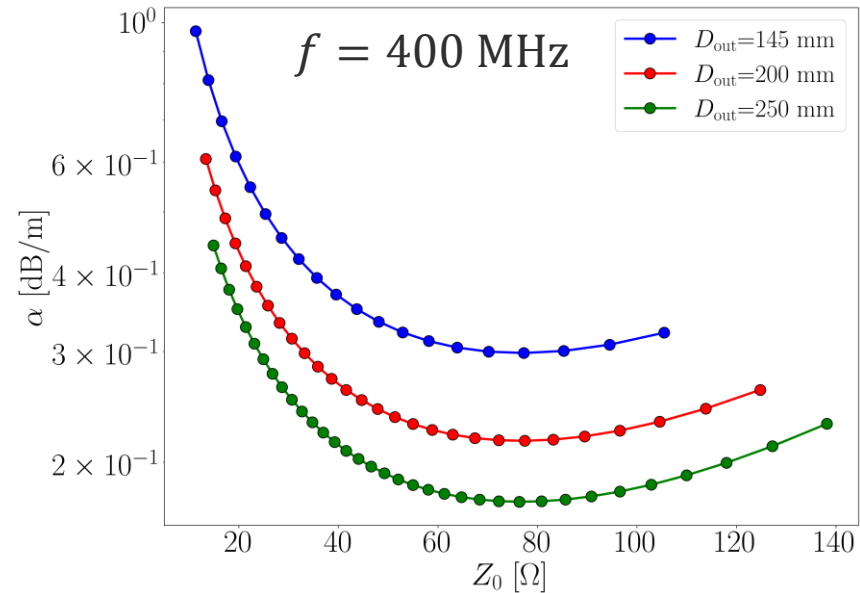
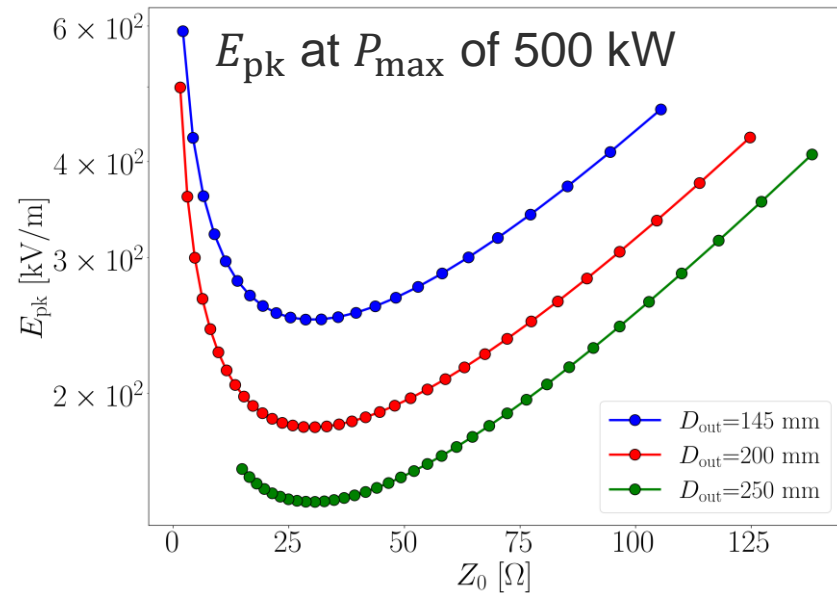

$$Z_c = \frac{60}{\sqrt{\epsilon_r}} \ln\left(\frac{D}{d}\right)$$

$$\alpha = \left(\frac{36.1}{Z_c}\right) \left(\frac{1}{D} + \frac{1}{d}\right) \sqrt{f} + 9.1 \sqrt{\epsilon_r} \tan\delta f$$

$$V_{peakmax} = E \frac{d}{2} \ln\left(\frac{D}{d}\right)$$

$$P_{peakmax} = \frac{E^2 d^2 \sqrt{\epsilon_r}}{480} \ln\left(\frac{D}{d}\right)$$

α = attenuation constant, dB/m

Z_c = characteristic impedance in Ω

f = frequency in MHz

D = inside electrical diameter of outer conductor in mm

d = outside electrical diameter of inner conductor in mm

ϵ_r = relative permittivity of dielectric

$\tan \delta$ = loss factor of dielectric

E. Montesinos, RF power transport, CAS course on RF for Accelerators, Berlin July 2023

- Minimum peak electric field occurs near 30 Ω impedance, while conductor losses are minimized around 77 Ω
- Multipacting onset power is higher at larger impedances, due to the increased gap between inner and outer conductors

Coaxial coupler update at 800 MHz

- Coaxial disk window is used in the coupler design
- The cone shape helps lower peak fields on the window by reducing impedance to $\sim 27 \Omega$ on the upper part; the lower part maintains 75Ω to reduce coaxial line losses on the vacuum side and avoid direct line-of-sight between the window and the cold cavity surface & beam
- Coupler shape, waveguide height, step, and window location are optimized as part of the matching section to ensure low transmission at 801.58 MHz
- The bandwidth is wide enough to damp lower-order modes of the cavity in the 785 MHz to 800 MHz range

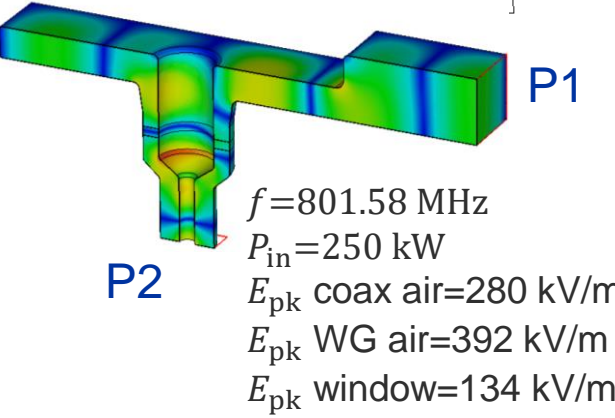
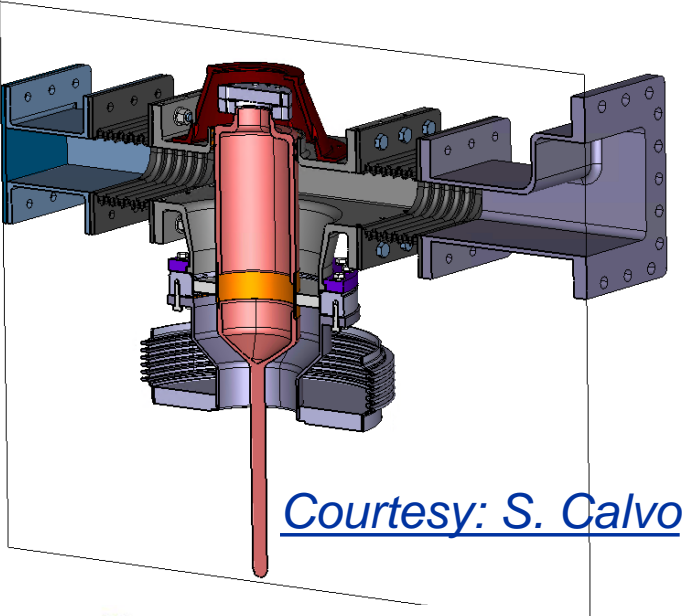
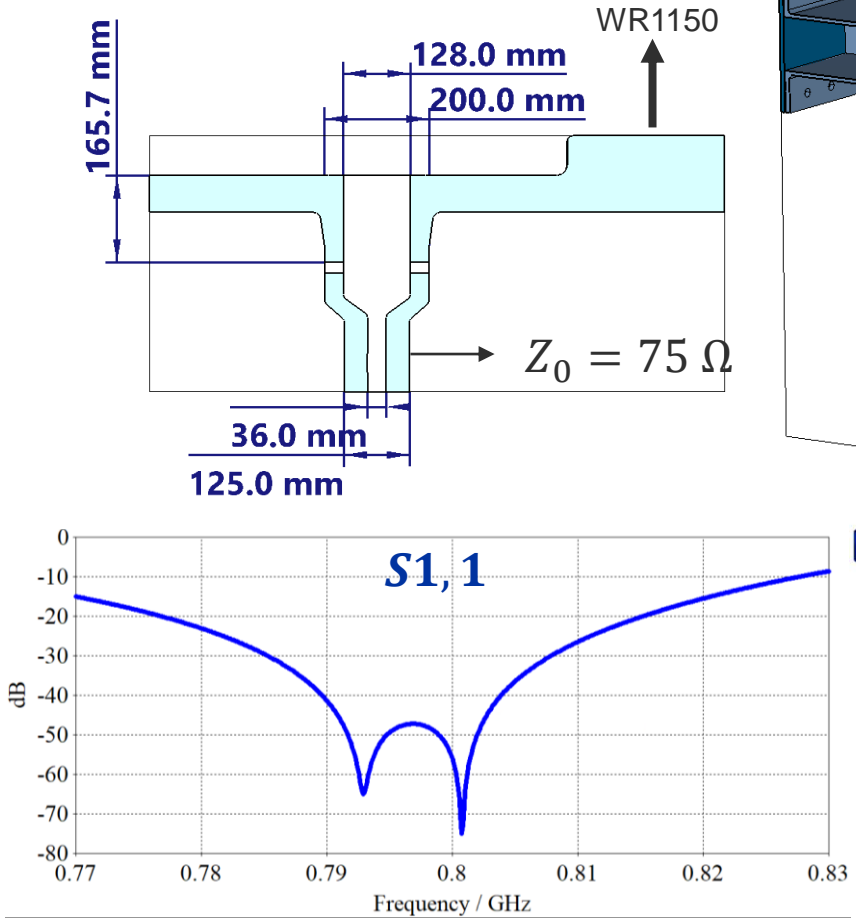

Q_{ext} tuning of 800 MHz FPC

- Q_{ext} tuning is performed by changing the length of the waveguide behind the FPC on the air side
- Larger d_{tip} preferred for booster cavities to avoid steep tuning curve \rightarrow requires different antenna length

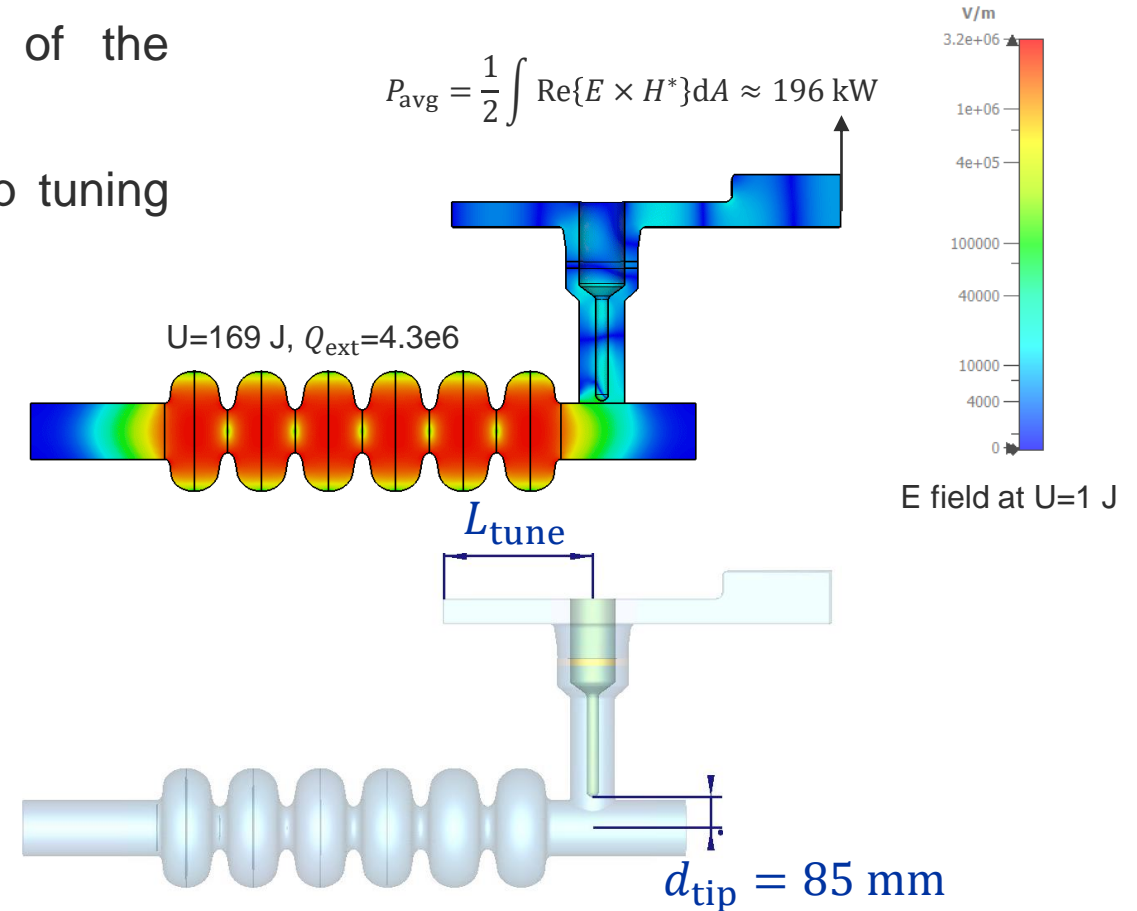
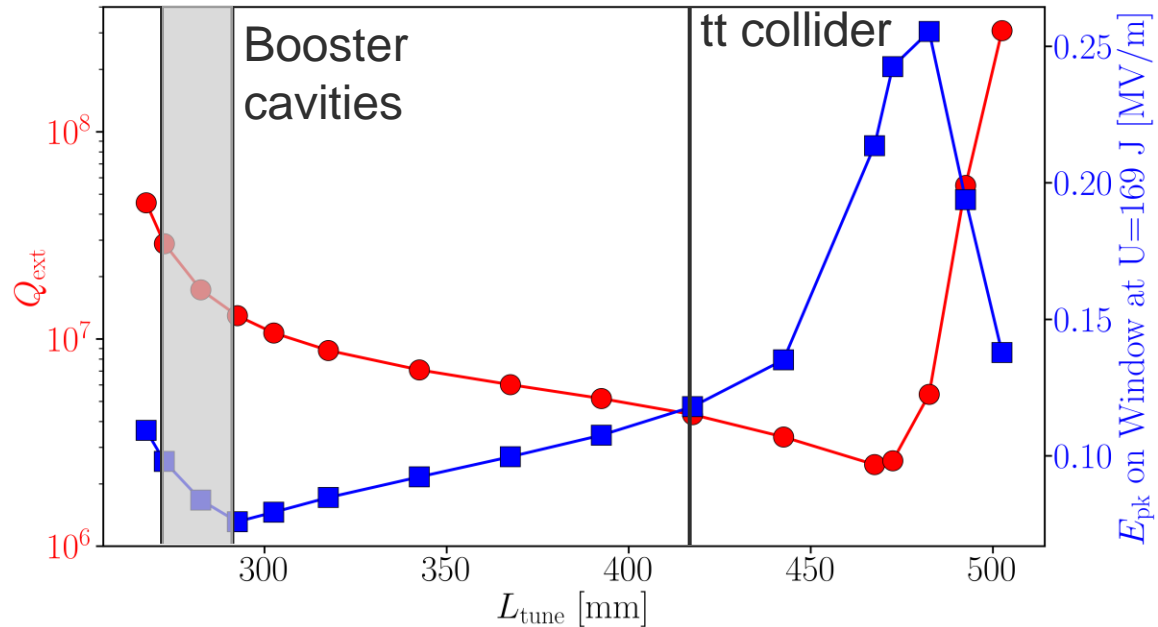

400 MHz power coupler

- Disk window based on the LINAC4 window design
- The matching is done by adjusting the waveguide height and length, window location and the step size in front of the window
- Robust design with large bandwidth. Peak fields centered, away from brazing joints. High thermal losses at window demand air-side cooling
- Challenging to integrate into cryostat → see Karin's presentation

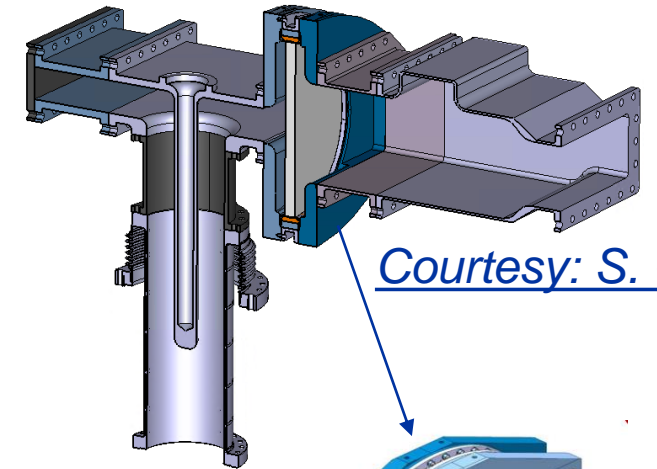

Courtesy: S. Calvo

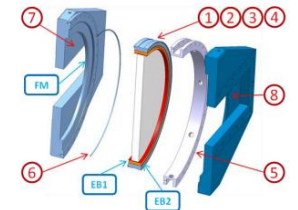
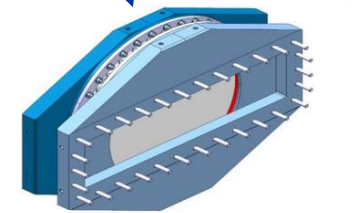
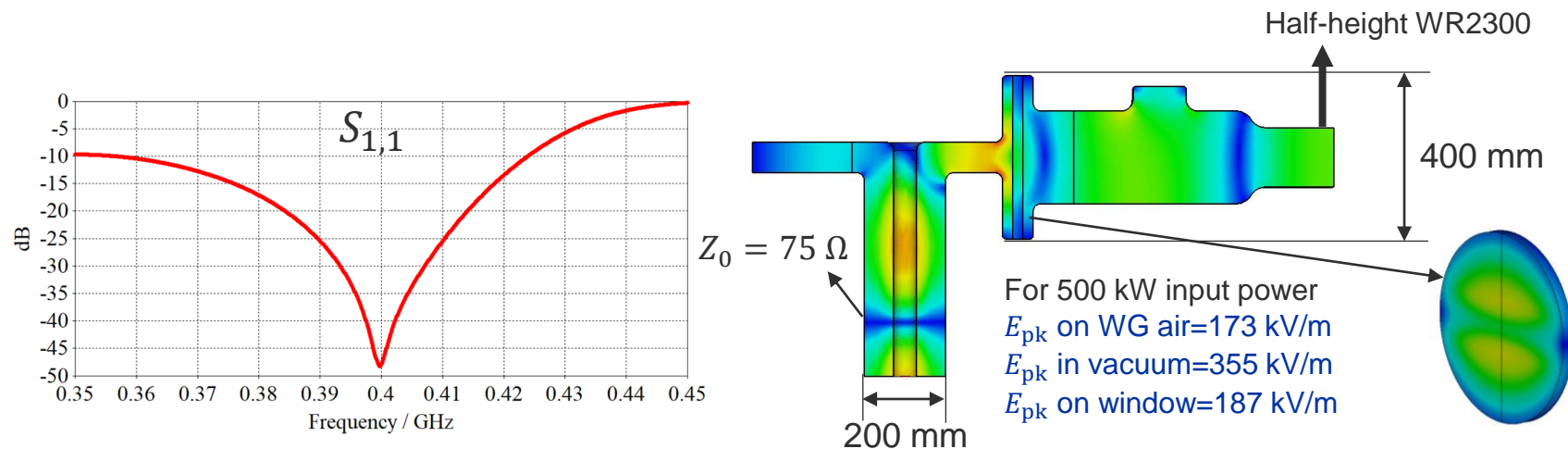

F. Gerigk, et al. The LINAC4 power coupler

Q_{ext} tuning of 400 MHz FPC

- Q_{ext} is tuned by changing the stub tuner length on the air side
- The Q_{ext} of the 0-mode in the FM passband is similar to that of the fundamental mode

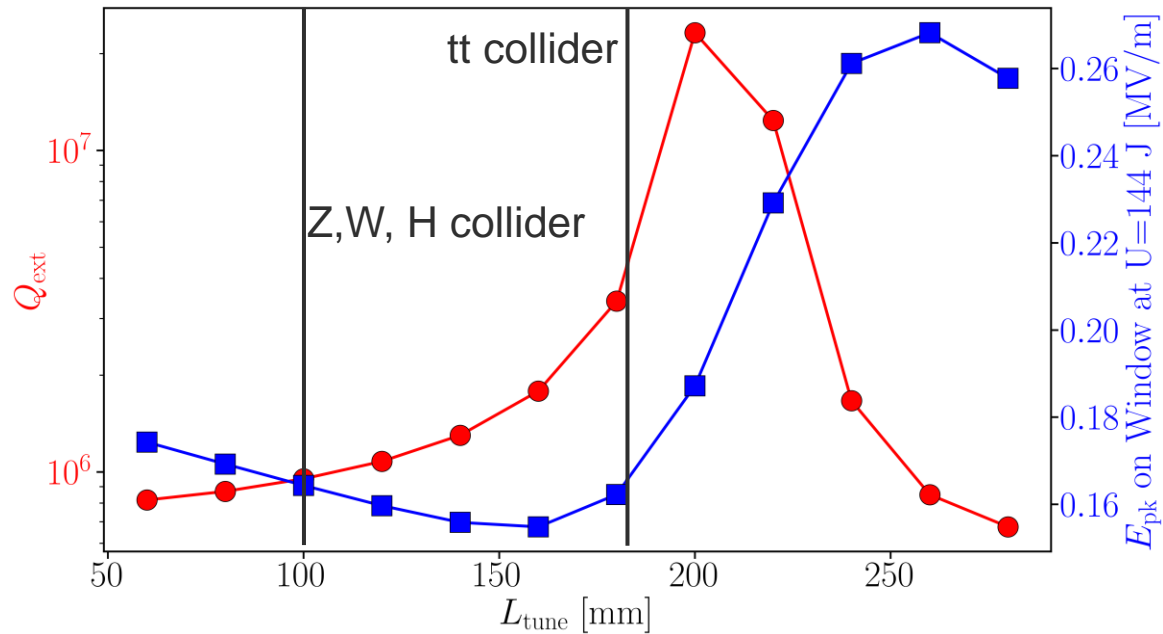
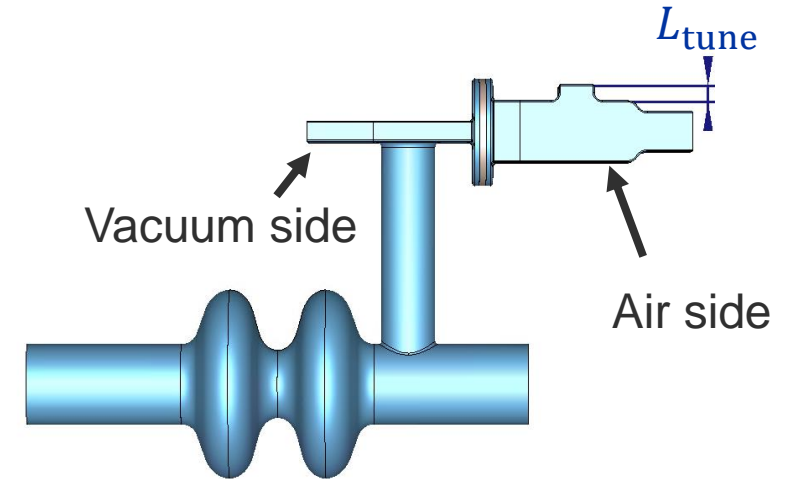

$$P_{\text{avg}} = \frac{1}{2} \int \text{Re}\{E \times H^*\} dA \approx 382 \text{ kW}$$

$U=144 \text{ J}$
 $Q_{\text{ext}}=9.49\text{e}5$

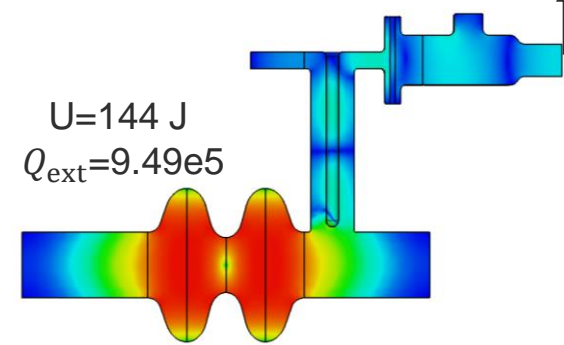

FM: π - mode

$f = 397.6 \text{ MHz}$
 $Q_{\text{ext}} = 9.45\text{e}5$

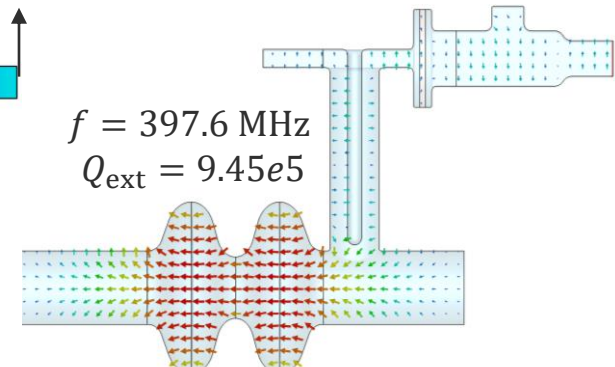

0 - mode

Summary and outlook

Summary

- 800 MHz: coaxial disk window with conical shape to reduce peak electric fields on the window and “hide” window from the cold cavity surface
- 400 MHz: Linac4-style disk window on the waveguide for high power handling at 400 MHz
- Both designs use $75\ \Omega$ impedance in the lower coaxial section to reduce losses and intensity of multipacting
- Q_{ext} tuning achieved via air-side waveguide geometry modifications and bandwidths are sufficient to cover lower-order modes within the FM passband

Outlook

- Detailed mechanical design and thermal (cool-down) requirements are ongoing
- The difficulties with space constraints and cryomodule integration have created a strong drive for more compact design solutions. The relatively lower power and Q_{ext} tuning range in RPO facilitate this design shift. A more compact coupler design is being explored

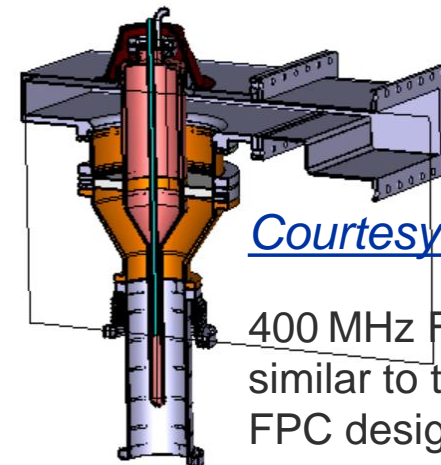

Courtesy: S. Calvo

400 MHz FPC concept similar to the 800 MHz FPC design

Appendix

Window families at CERN

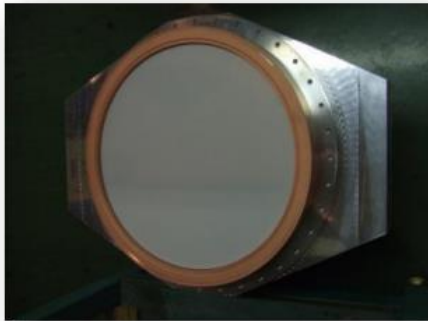

Disk windows

SPS, 800 MHz
150 kW CW

Linac4, 352 MHz
1 MW 10 % duty

LHC 2, 400 MHz
1 MW (expected) CW



Cylindrical windows

LHC, 400 MHz
500 kW CW

ESRF/SOLEIL/APS, 352 MHz
250 kW CW

SPL, 704 MHz
1 MW 5 % duty

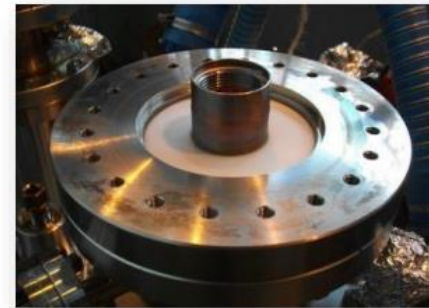

Coaxial disk windows

HL-LHC Crab, 400 MHz
100 kW CW

SPL 2.0, 704 MHz
1 MW 5 % duty

SPL 3.0, 704 MHz
2 MW (expected) 5 % duty

CERN power couplers since 2000's

LHC	400 MHz, 500 kW CW SW
SPS 2.0	200 MHz, 750 kW CW TW
SPL 2.0	704 MHz, 900 kWp 10 % SW
SPL 3.0	704 MHz, 1000 kWp 10 % SW
Linac4	352 MHz, 1000 kWp 10 % SW
Crab DQW	400 MHz, 100 kW CW SW
Crab RFD	400 MHz, 100 kW CW SW
ESRF	352 MHz, 200 kW CW SW
SOLEIL	352 MHz, 200 kW CW SW
APS 1.0	352 MHz, 200 kW CW SW
SPS LIU	200 MHz, 800 kW CW TW
HG (SPL 3.0)	704 MHz, 1500 kWp 10 % SW
LHC 2.0	400 MHz, 500 kW CW SW
APS 2.0	352 MHz, 250 kW CW SW

[E Montesinos, FCC couplers, SRF workshop CERN, 2024](#)

[E. Montesinos, RF power transport, CAS course on RF for Accelerators, Berlin July 2023](#)

800 MHz FM passband

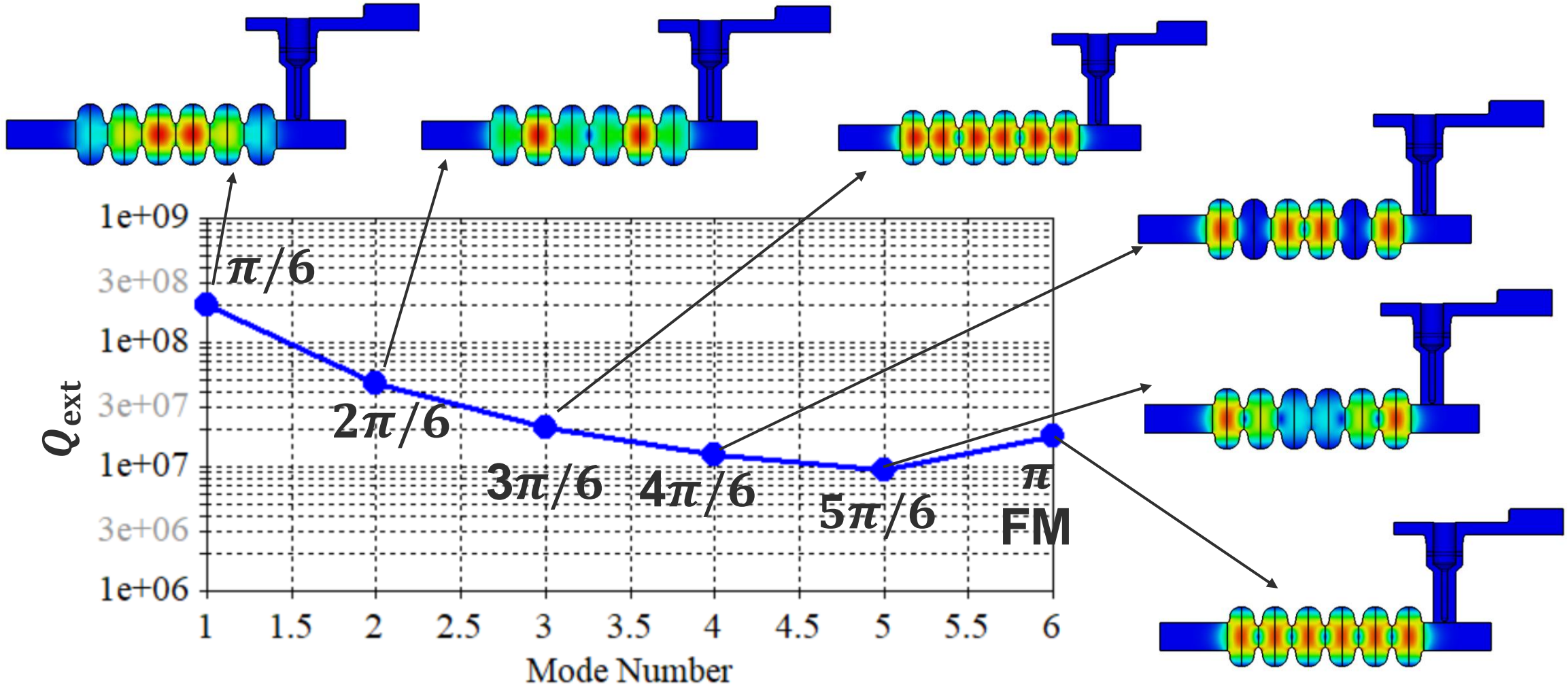

Lower order modes (I)

Mode 1

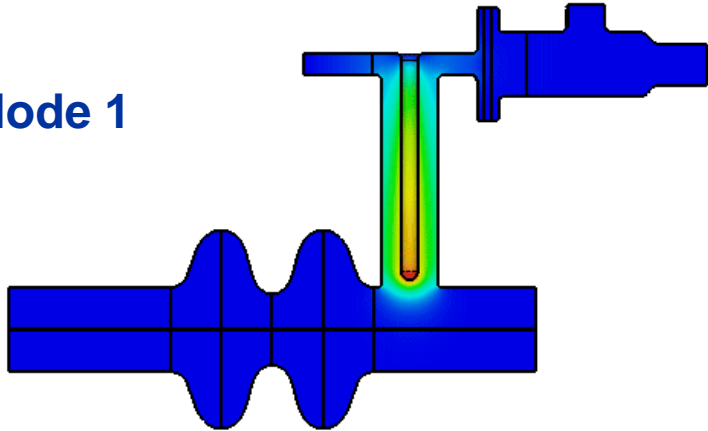

$d_{\text{tip}} = 175 \text{ mm}, f = 83.55 \text{ MHz}, Q_0 = 7.5e3, R/Q = 0.013 \Omega$

Mode 2

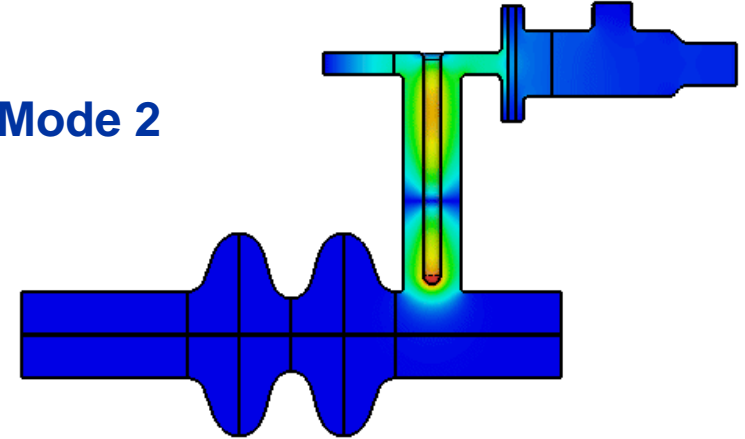

$d_{\text{tip}} = 175 \text{ mm}, f = 243.45 \text{ MHz}, Q_0 = 12.5e3, R/Q = 0.032 \Omega$

If one of the two modes trapped in the FPC gets excited by the beam, additional power could be induced and dissipated on the FPC outer wall and inner coax.

d_{tip} [mm]	Mode	P_{HOM} [W] (at $I = 1.28 \text{ A}$)	P_{loss} [W] Inner coax (Cu)	P_{loss} [W] Outer coax (Cu)	P_{loss} [W] Upper WG (Al)
175	1	160	94	22	44
175	2	655	344	90	221

$$P_{\text{HOM}} = R/Q \cdot Q_0 \cdot I^2$$

LOM frequency shift

To address LOM excitation and potential coupler overheating in worst-case scenarios:

- **If beam spectral lines are known:** Slightly adjust the inner antenna length in the initial design to shift the LOM frequency away from the beam spectral lines.
- **If beam spectral lines are unknown:** Introduce flexibility in the geometry e.g., changing the volume above the FPC by 1 mm (as shown in the figure below by moving a short plane or membrane above inner coax) can shift mode frequencies by more than one bandwidth.

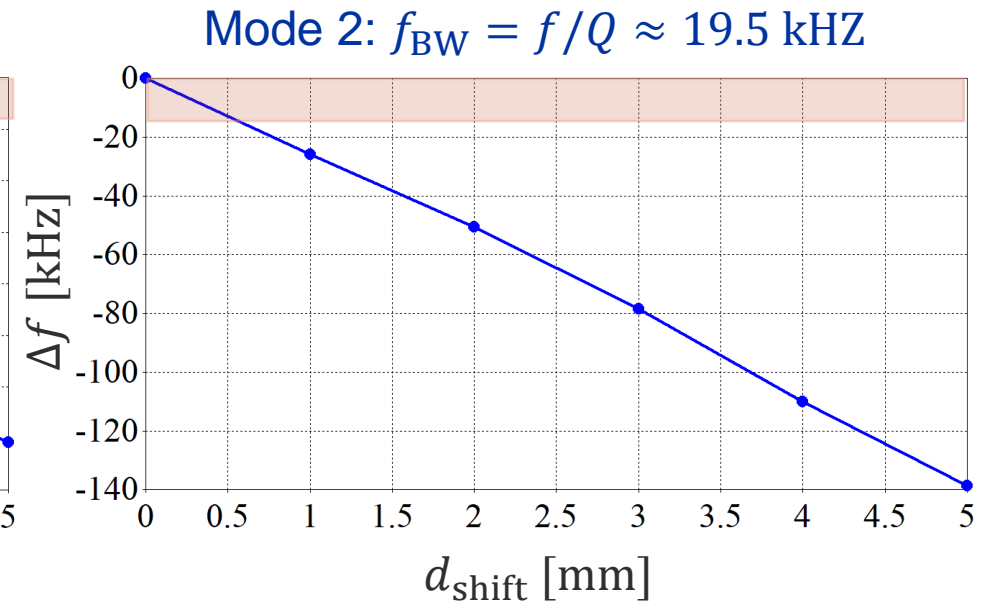
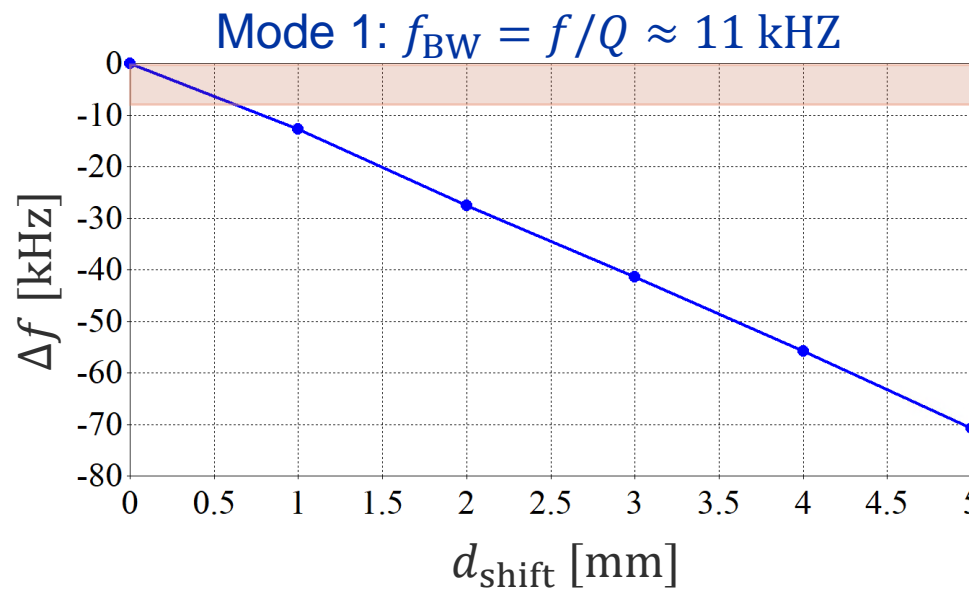
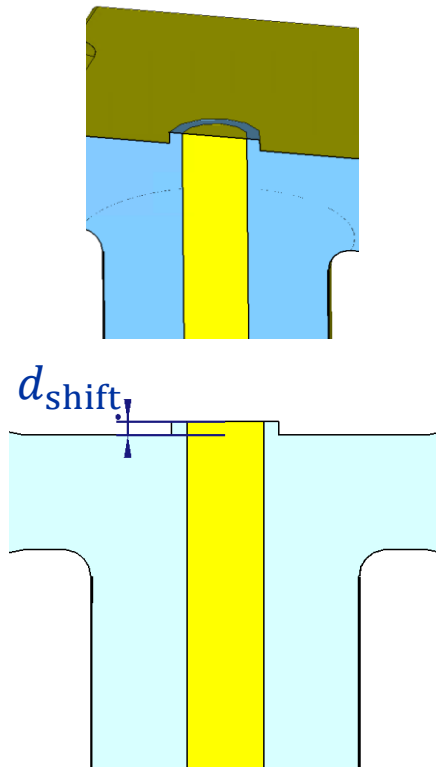

MP in conical coax

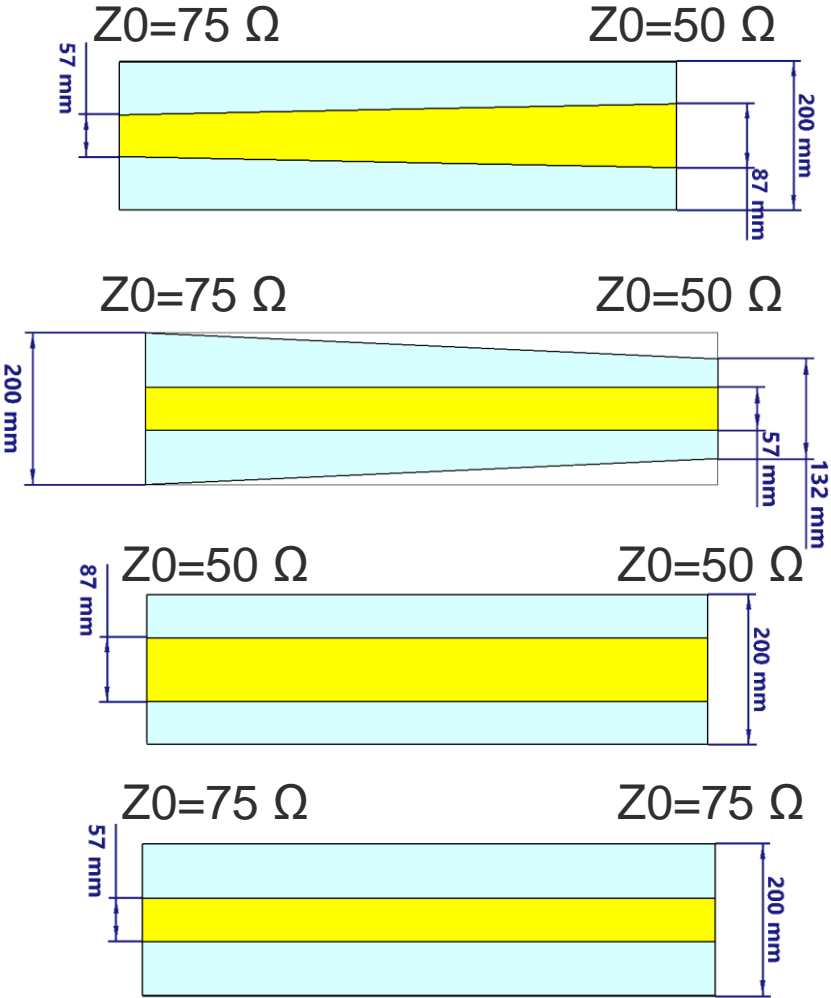

VIDEO CONFIGURATION
 Registry: Circuit
 Signal: SW 1
 Centers: 1
 Frequency: 0.40079 GHz
 Power: 200000 W/center
 Start Time: 0 s
 End Time: 2e-07 s
 Frames / period (approx): 15

Elementary Charge Component
 1.000e+00 127 2.520e+02

$P=200 \text{ kW}$, $f=400.79 \text{ MHz}$, growth factor=5

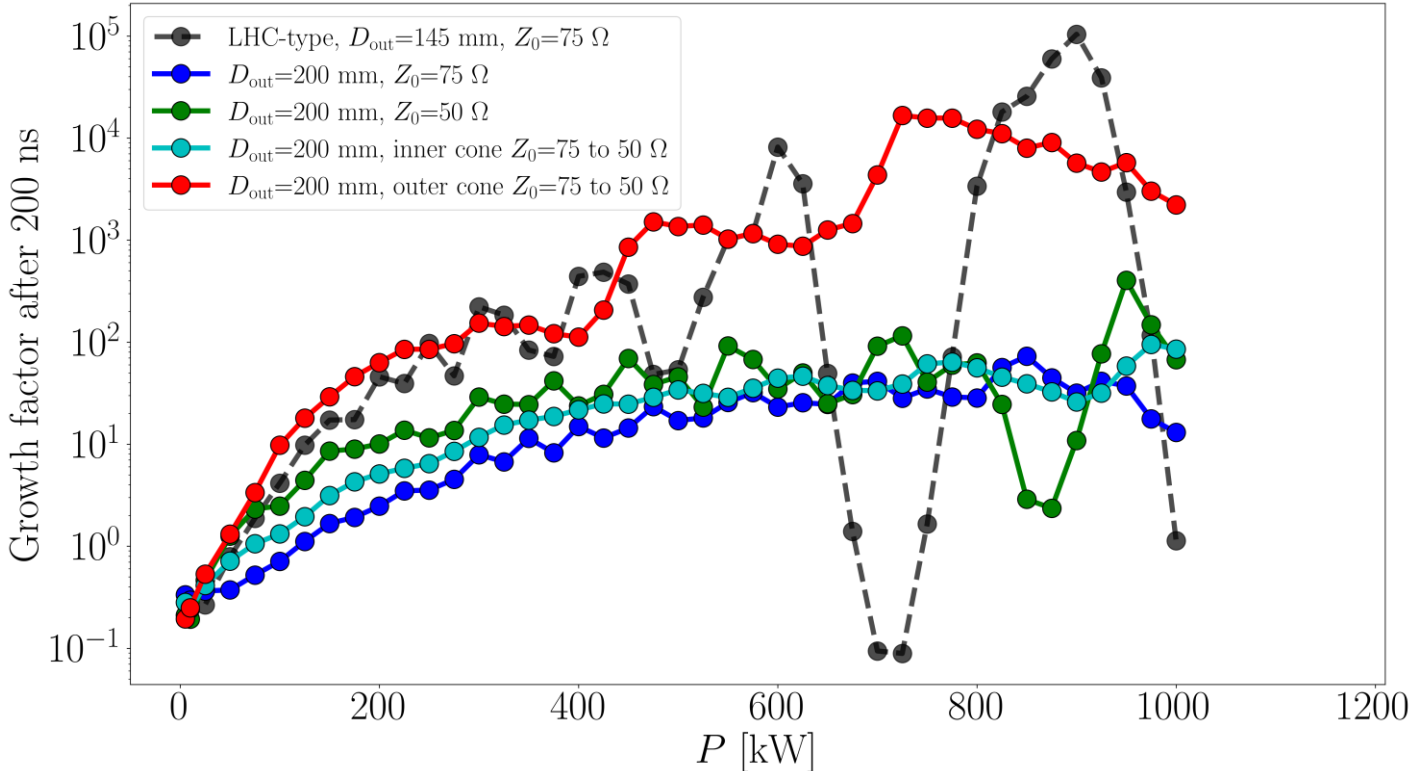
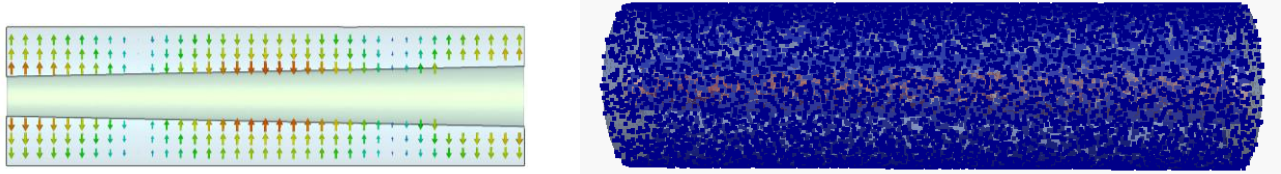

Multipacting analysis of the disk window

$$N(t) = N_0 e^{\alpha t}$$

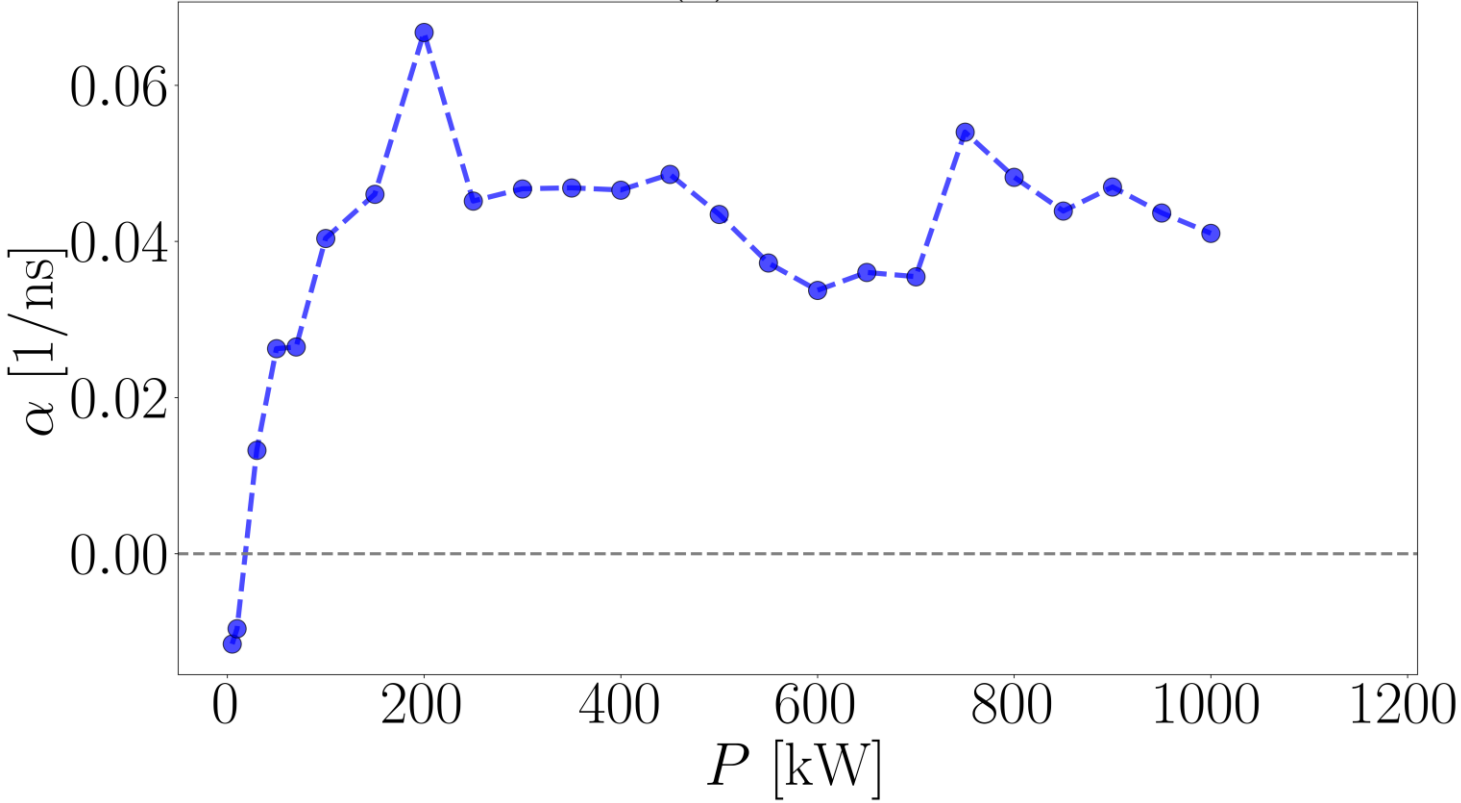

$P = 400$ kW
Average Multipacting order = 9.1

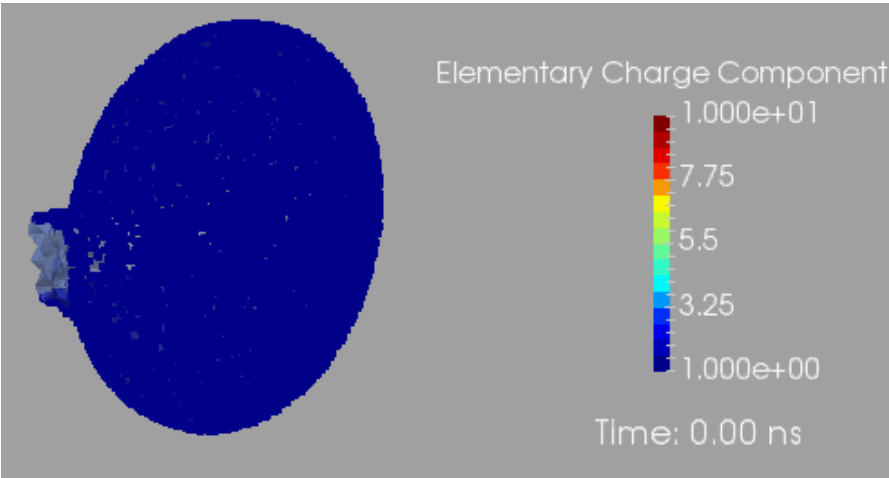

There are hot zones of high order multipacting on the margins of the window

MP in different LHC coupler zones

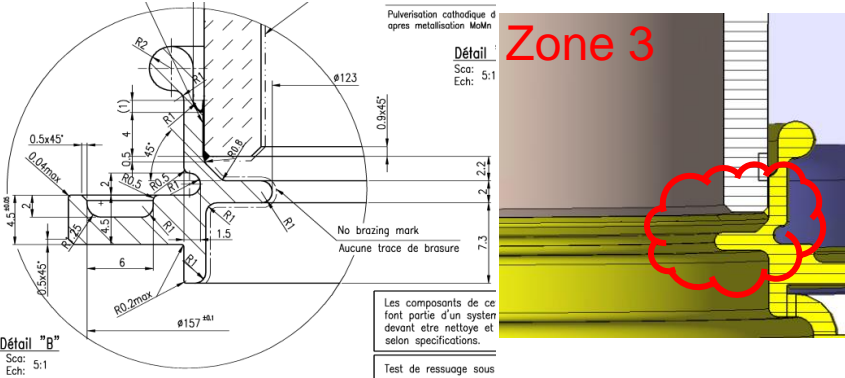

<https://edms.cern.ch/ui/file/194664/AE/lhcacsmc0069-vAE.pdf>

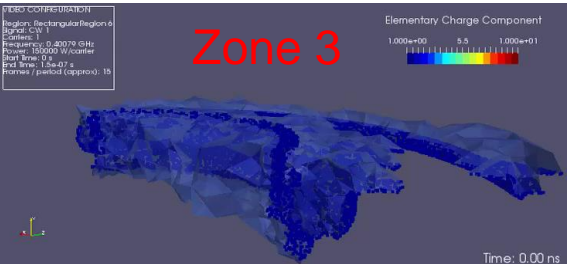
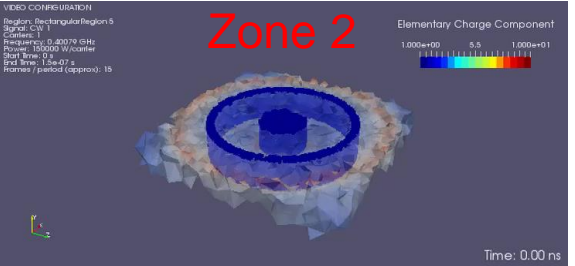
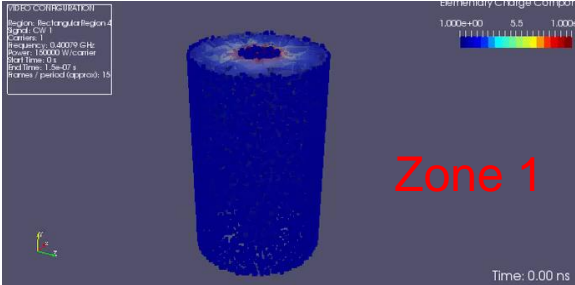

150 kW input power

