

WOW and SWELL cavities (preliminary) test results

**F. Peauger, S. Gorgi Zadeh, M. Therasse, A. Sublet, G. Rosaz, W. Venturini Delsolaro,
A. Durdevic, C. Barbagallo, N. Stapley, M. Battista, G. Pechaud, M. Chiodini, J. Bastard, C.
Duval, F. Jeanroy, Z. Jankovic, M. Gourragne, Y. Cuvet, F. Pelloux.**

22 May 2025

WOW cavity

WOW, Wide Open Waveguide cavity

Crab cavity for FCC-hh with niobium on copper technology

Design by Alexej Grudiev, Kei Papke

| Parameter | FCC-WOW | LHC-DQW |
|--|---------|---------|
| Frequency (MHz) | 400 | 400 |
| Geometry factor G (Ω) | 108.9 | 87 |
| Deflecting voltage V_t (MV) | 3.0 | 3.4 |
| R_f/Q (linac Ω) | 343.5 | 430 |
| E_{pk} at V_t (MV/m) | 45.3 | 37.6 |
| B_{pk} at V_t (mT) | 78.3 | 72.8 |
| $\text{Kappa} = 1/(R_f/Q \cdot \omega)$ (J/(MV) ²) | 1.1560 | 0.9235 |

[Design studies of a compact superconducting rf crab cavity for future colliders using Nb/Cu technology](#)

[Multiphysics Simulations of the Wide Opened Waveguide Crab-cavity \(cern.ch\)](#)

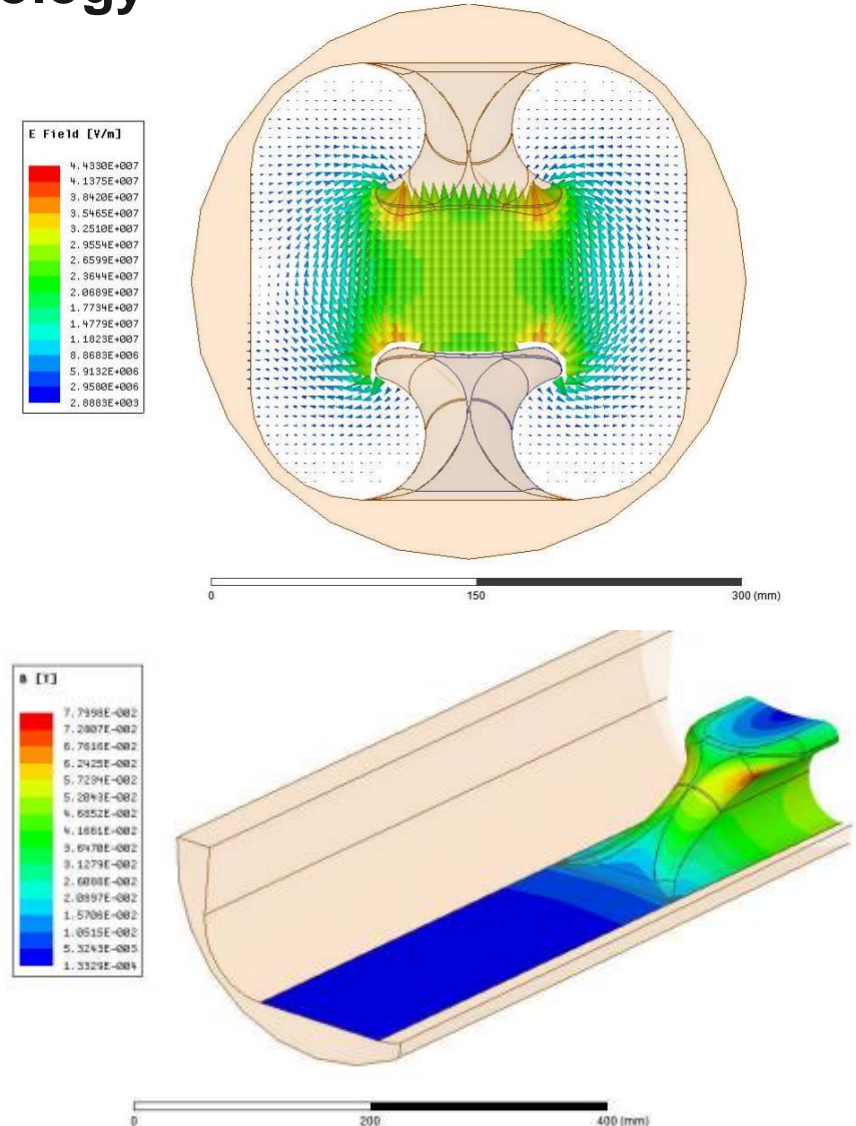

WOW Cavity niobium coating

Courtesy Alban Sublet et al.

- A unique R&D object for Nb on Cu technology
- Coating of a complex and large substrate
- 6 cathodes used in parallel
- HiPIMS process used to have dense film

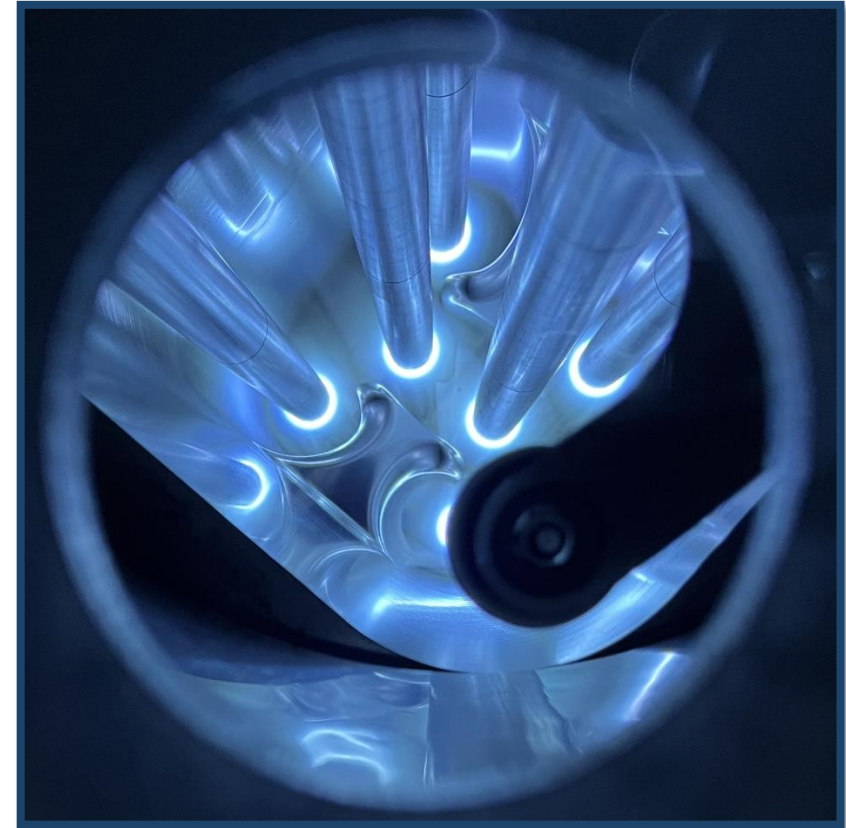

[CERN_SRF_WOW-SWELL_AS-GR.pdf](#)

WOW cavity clean room preparation

Low Pressure Water Rinsing (1 hour) followed by alcohol rinsing / drying and closing with flanges and antennas.

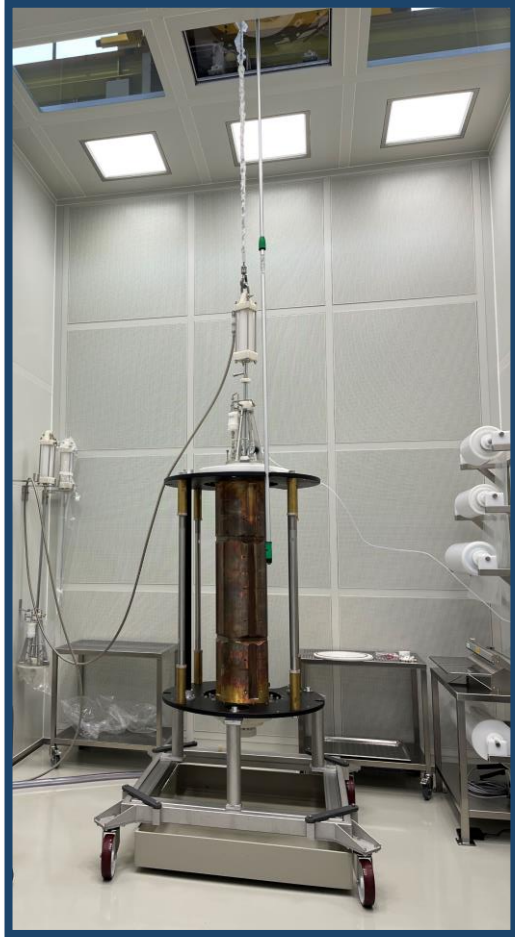

Installation in the vertical cryostat

- The cryogenic instrumentation includes level sensors (LT), Temperature sensors (TT), a heater and an evaporator.
- A new 3-axis magnetic sensor was installed in the middle of the cavity before cryostating
- After initial cooldown to 4.5 K, a thermal cycle up to 14 K with a compensation of the ambient magnetic field below $<0.15 \mu\text{T}$



RF coupling of antennas

During the first test in October 2024, the coupling was far from the optimal condition leading to inaccurate results.

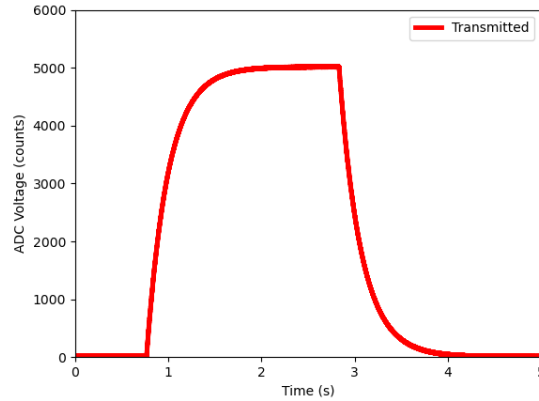
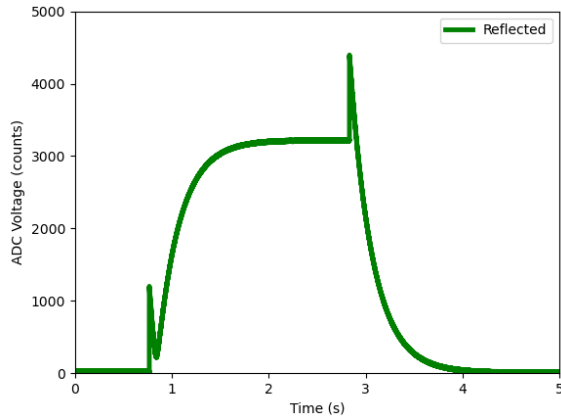

$$Q_i = 3.3 \times 10^8$$

$$\beta_i = 12.5$$

$$Q_t = 2 \times 10^{10}$$

$$\beta_t = 0.2$$

at 4.5 K

$$Q_0 = 4 \times 10^9$$

“strongly”
overcoupled

$$Q_i = 1.5 \times 10^9$$

$$\beta_i = 1.7$$

$$Q_t = 1.5 \times 10^{10}$$

$$\beta_t = 0.17$$

at 4.5 K

Surface
resistance

$$Q_0 = 2.5 \times 10^9$$

overcoupled

$$R_s = 44 \text{ n}\Omega$$

at 2 K

$$Q_0 = 1 \times 10^{10}$$

overcoupled

$$R_s = 11 \text{ n}\Omega$$

The coupling was changed with cavity kept on the insert by turning the input antenna loop by 70 degrees. The cavity was re-tested immediately after (November 2024).

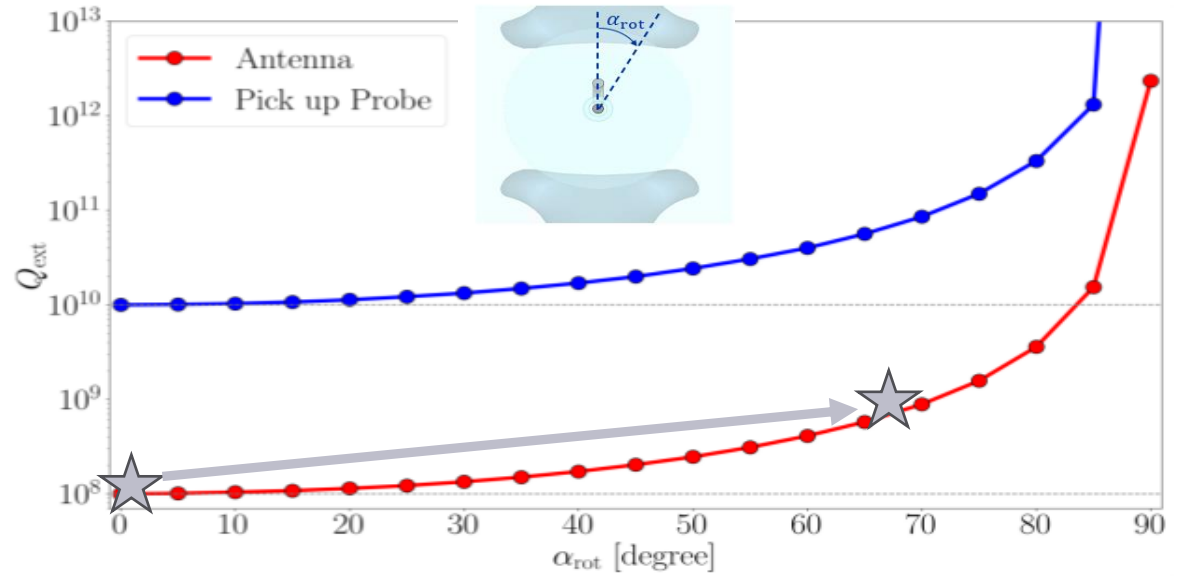

WOW cavity – Quench signature

Due to RF calibration inconsistencies (discovered after the test), we are not able to publish any Q0 vs Vt curves today.

When increasing the RF power, a quench behaviour was observed on the RF signals shape.

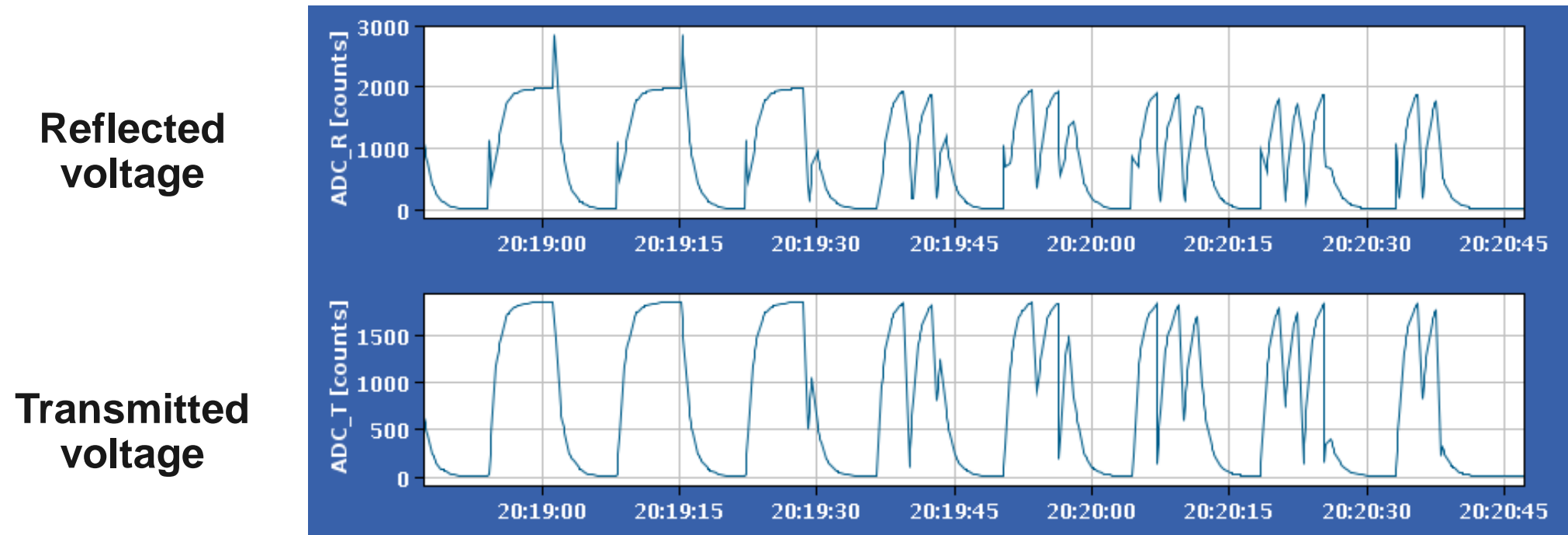

WOW cavity visual inspection after cold test

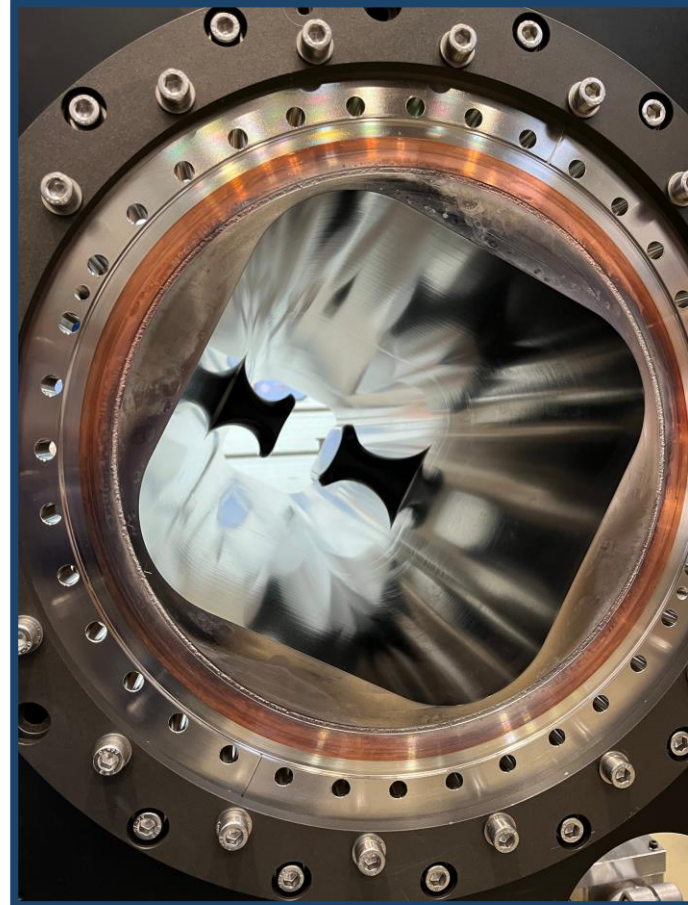

No damage on the surface was noticed.

New surface preparation and vertical test currently under discussion.

SWELL cavity

SWELL, Slotted Waveguide ELliptical cavity

Powerful approach for high current machine where strong damping of higher order transverse modes is achieved.

2-cell 400 MHz RF design

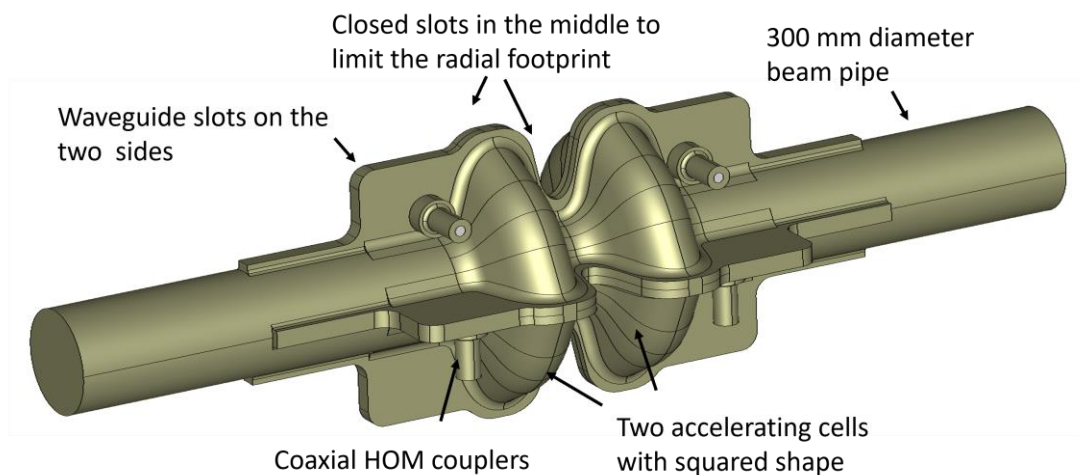

Transverse impedance

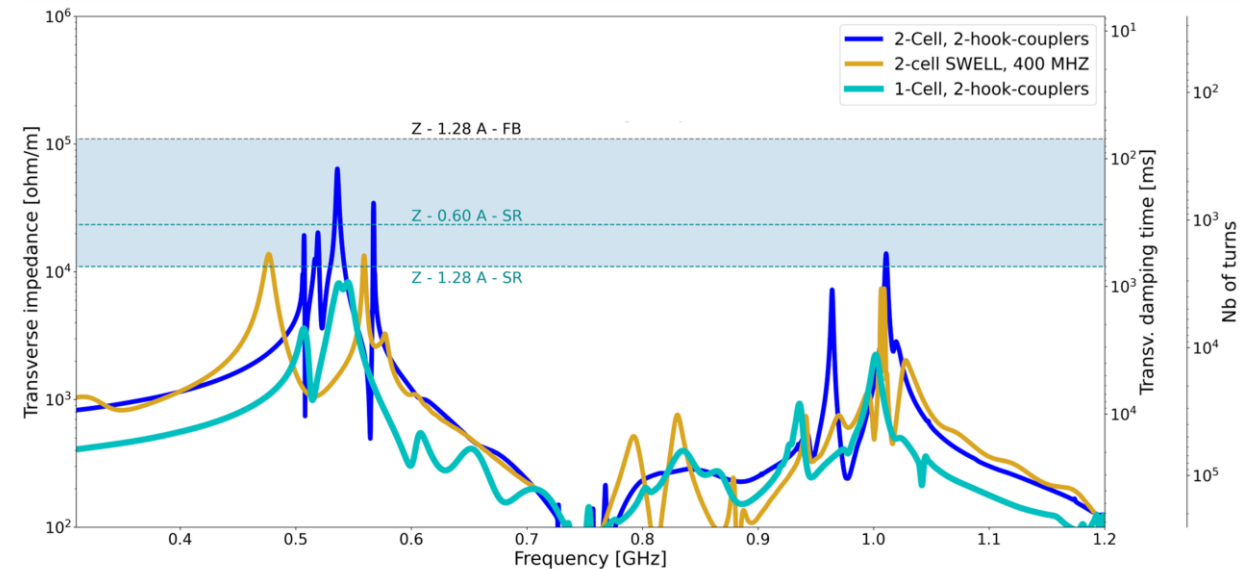

SWELL, a new SRF cavity concept

Easy access to the SRF surface for better quality control and processing.

Niobium coating is facilitated thanks to a planar configuration.

Cryogenic cooldown with reduced volume of liquid helium.

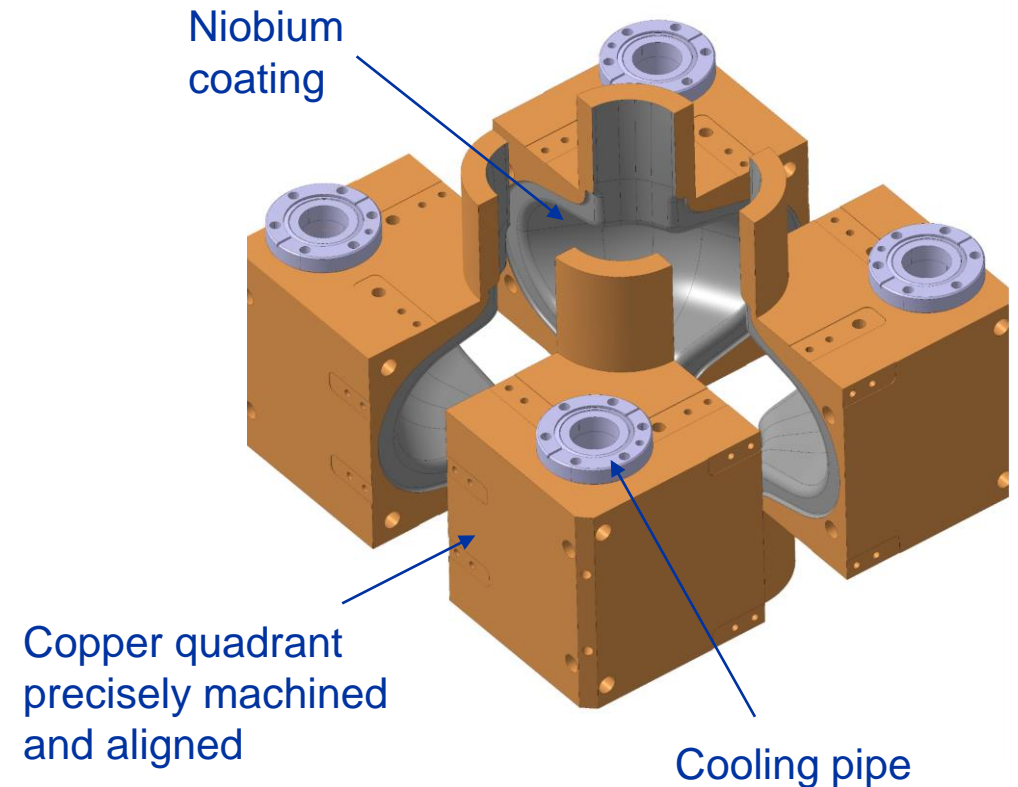

1.3 GHz SWELL RF parameters

| | SWELL |
|---------------------------------------|---------------------------------------|
| F (GHz) | 1.301 |
| R/Q linac (Ω) | 122.9 |
| Lacc (mm) | 115.3 |
| Epk/Eacc | 2 (same as TESLA cavity) |
| Bpk/Eacc (mT/(MV/m) ²) | 4.61 (+7.7% / TESLA cavity) |
| G (Ω) | 265.56 |

$$\text{Kappa} = L_{acc}^2 / (R/Q \cdot \omega) = 0.01323 \text{ J}/(\text{MV}/\text{m})^2$$

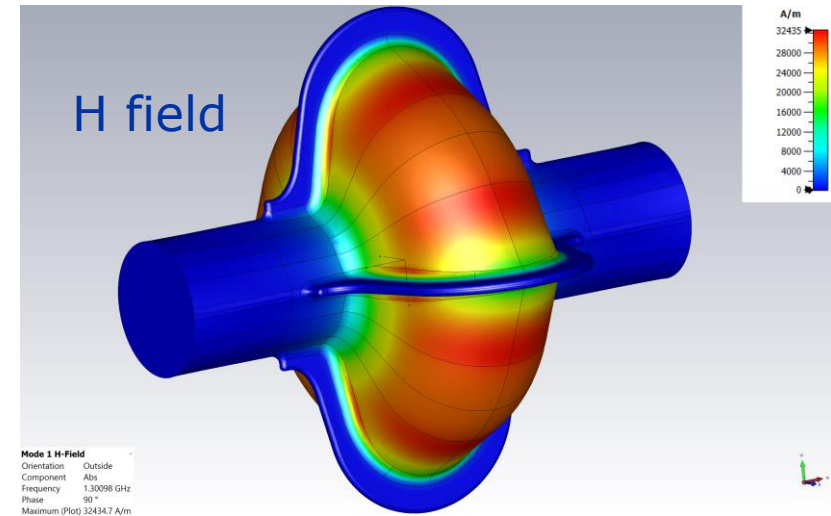
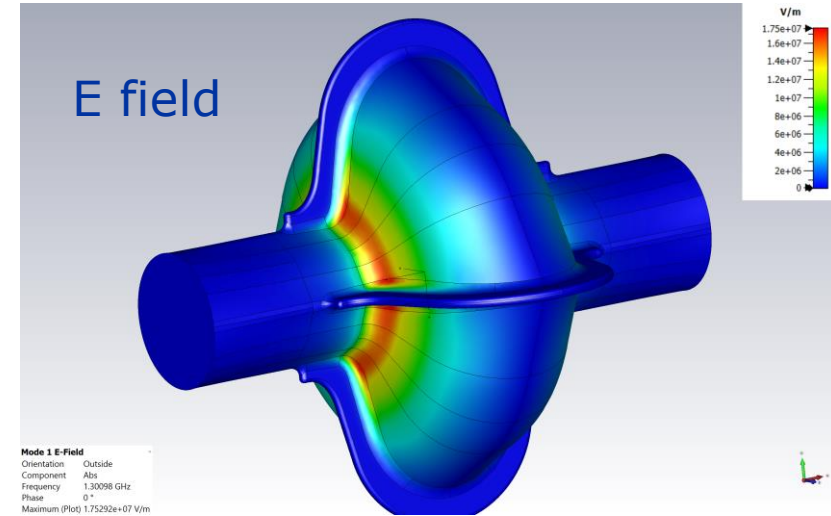

SWELL Niobium coating process

Courtesy Guillaume Rosaz et al.

- HiPIMS process used to have dense film
- Re-use of an existing coating chamber
- Planar cathod and linear motion rod + roller to move the quadrant
- Some issues at first attempts: peel-off after LPWR - > film thickness was increased



Clean room preparation

Low pressure water rinsing and drying of quadrants individually

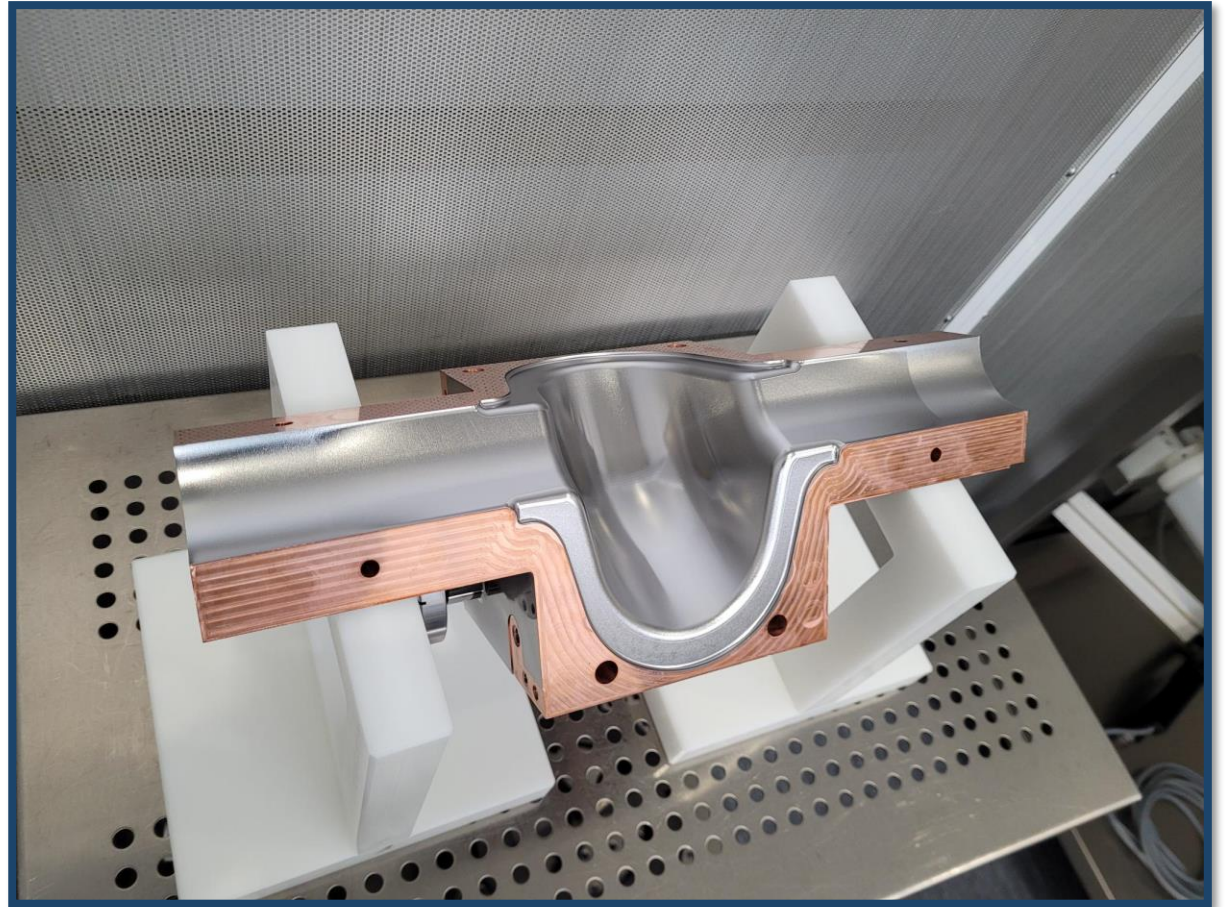

Test cryostat and insert for SWELL

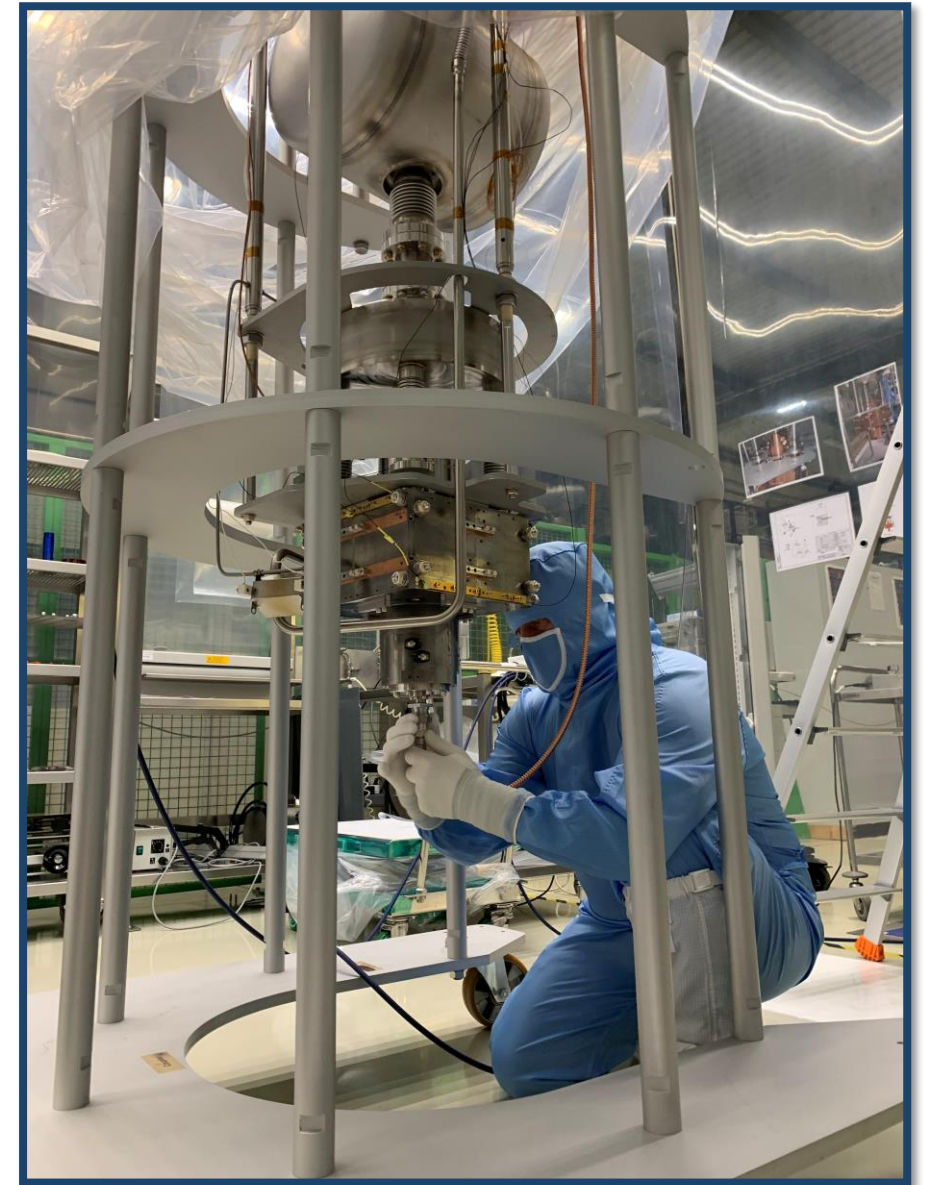
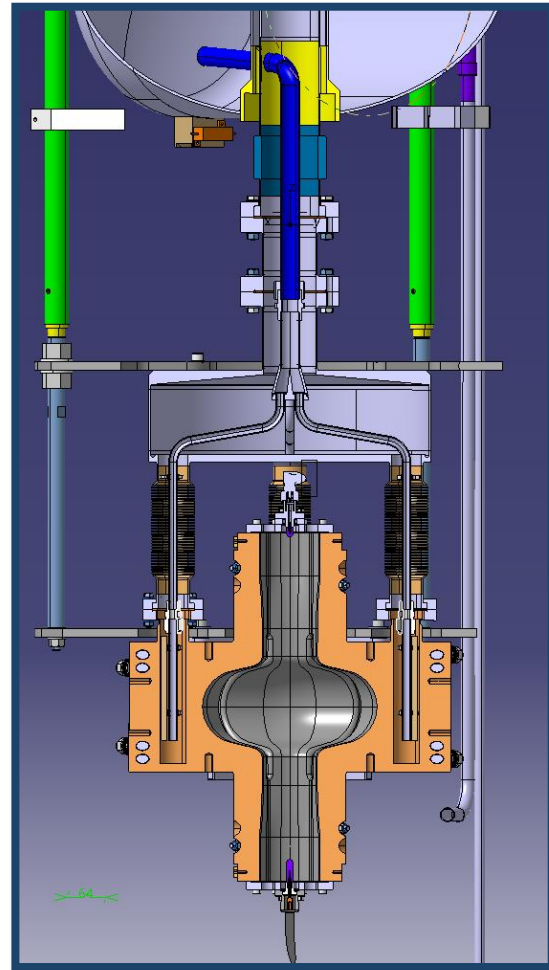
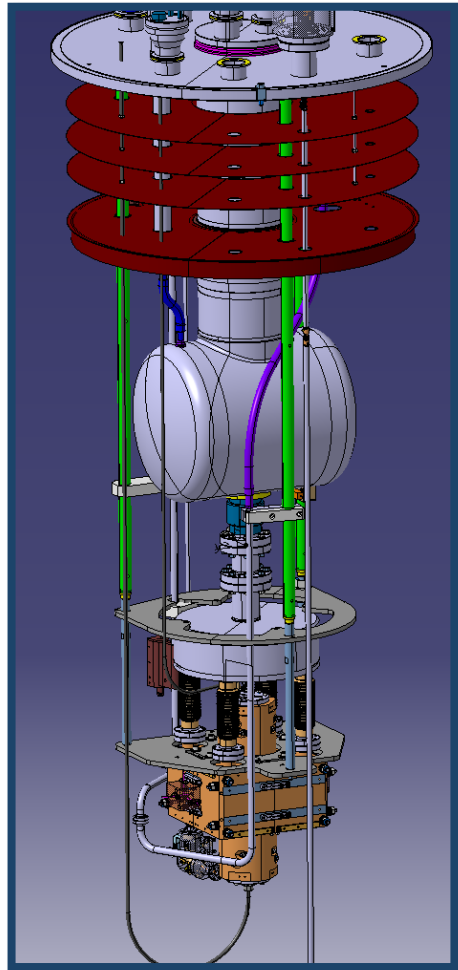

SWELL cavity – first Q_0 vs E_{acc} scan

September 2024

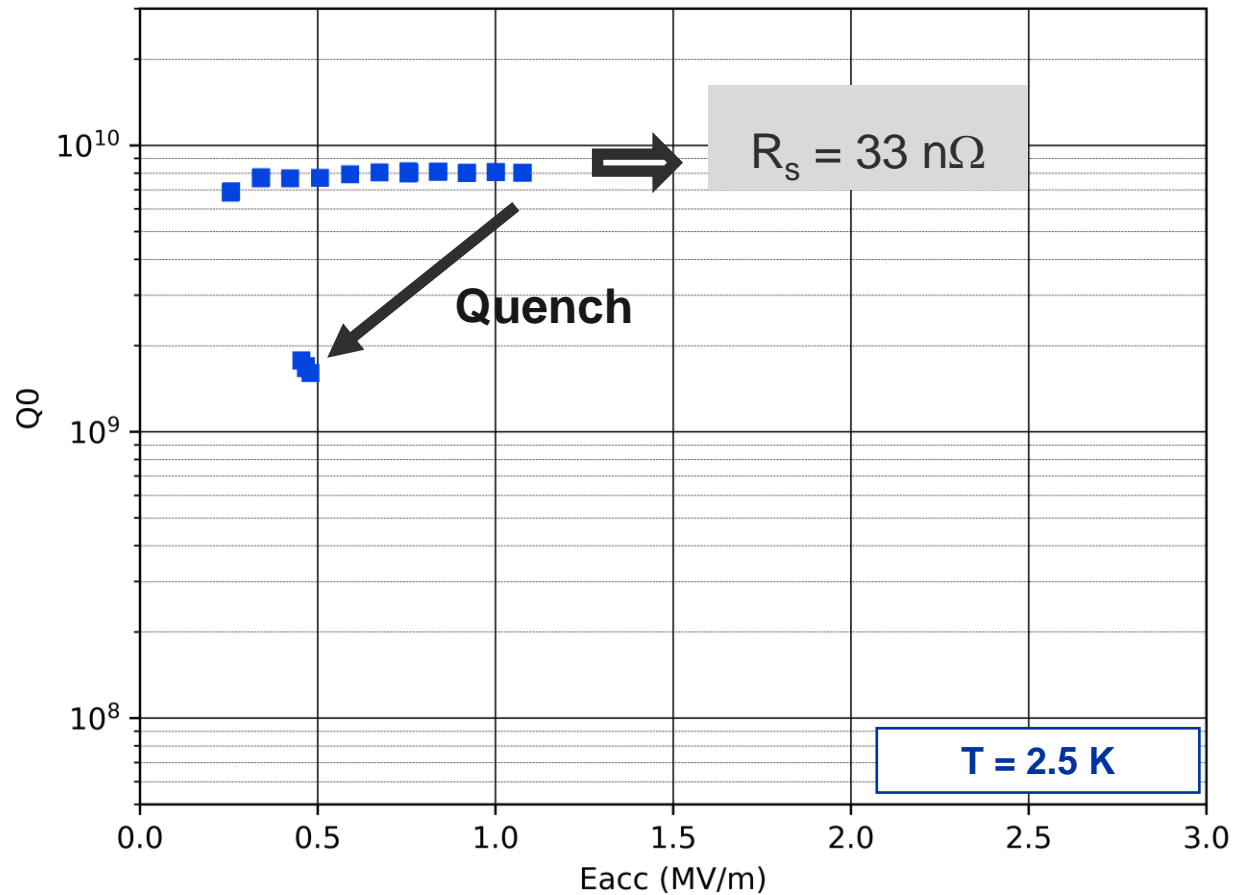

SWELL performances at 2.5 K

Q0 vs Eacc with various ambient B field

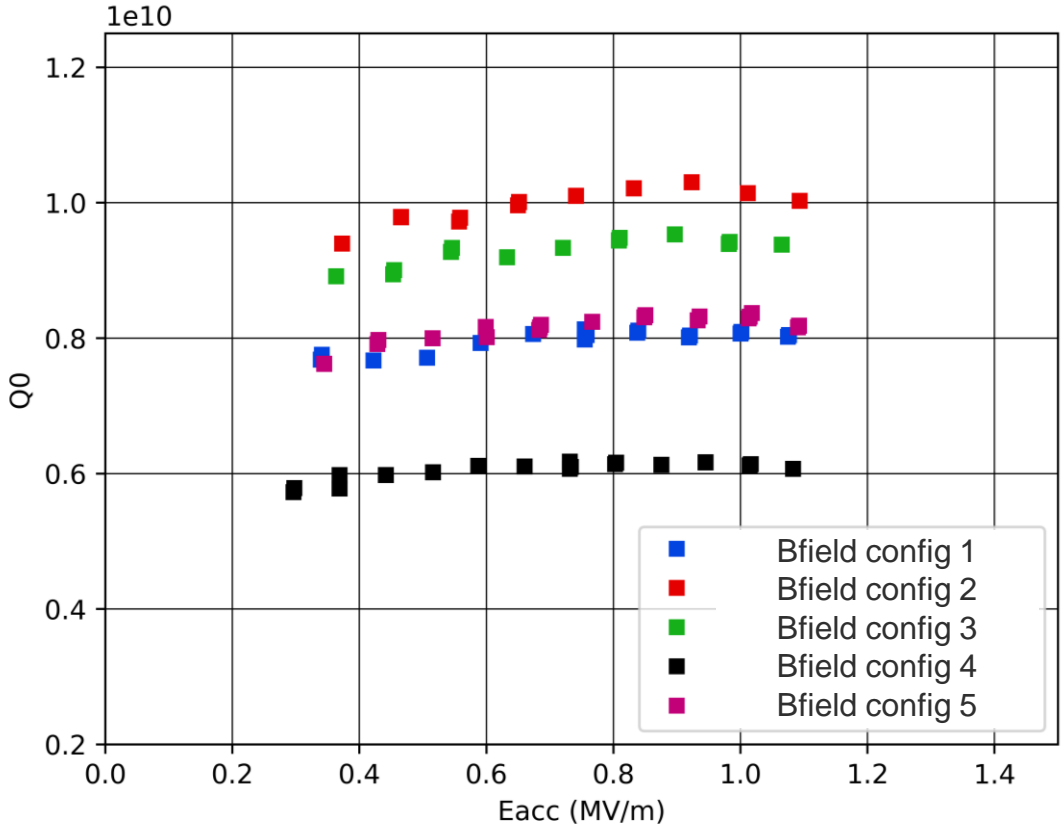

Surface resistance sensitivity to trapped magnetic field ~ 10 - 20 nΩ / gauss

Rs as a function of temperature

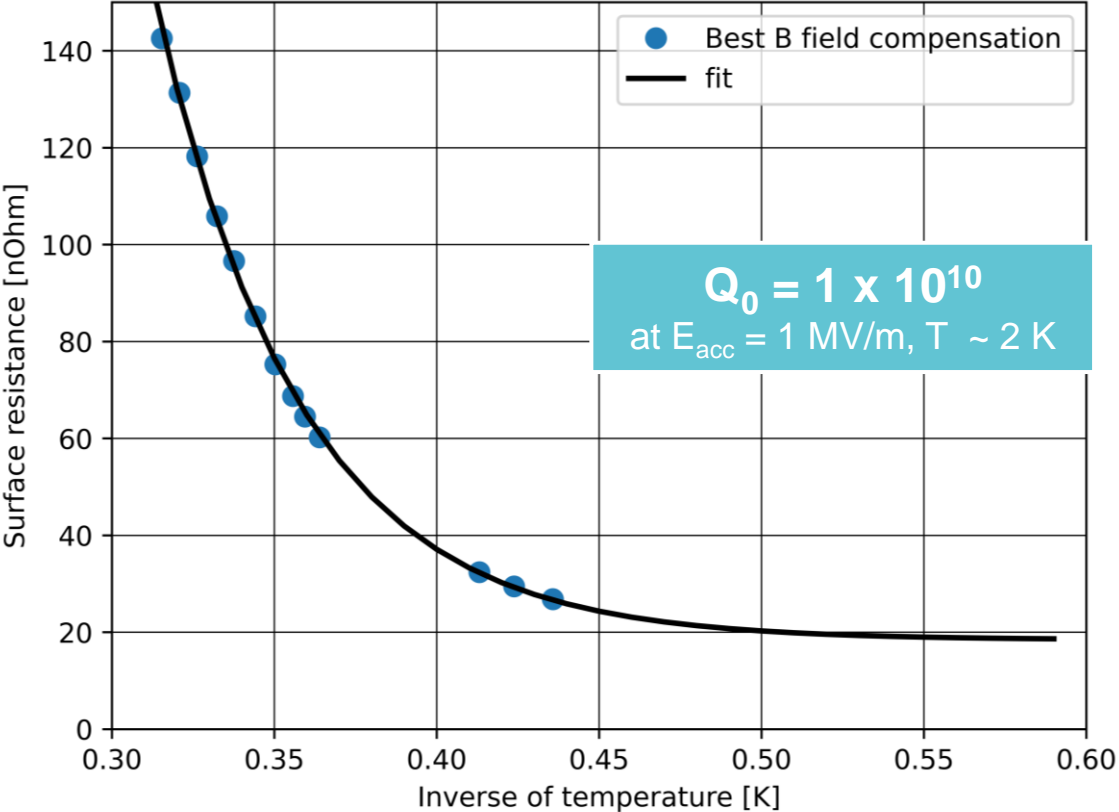

Residual resistance = 18.4 nΩ

Re-test after re-coating of one quadrant

- The quality factor at low field reached again $Q_0 = 1 \times 10^{10}$, the same level as before.
- At $E_{\text{acc}} = 2 \text{ MV/m}$, the Q_0 drops quickly without any sign of field emission.
- Two successive helium processing and a thermal cycle followed by some RF processing improved the maximum accelerating field up to $E_{\text{acc}} = 4 \text{ MV/m}$.

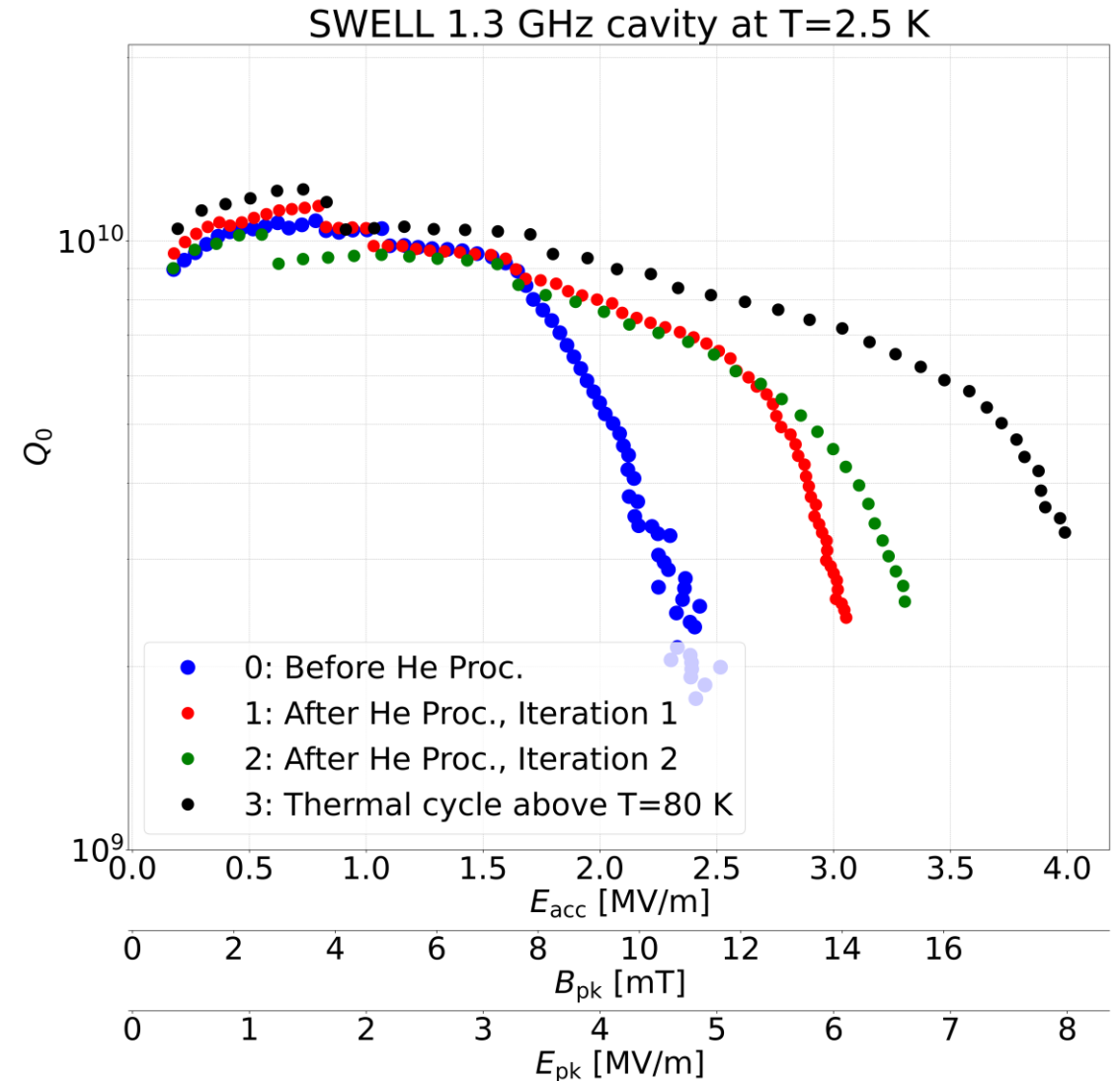

Comparison with PXI-based SEL

- New system developed with highly performant (direct sampling) and industrialized technology (National Instrument).
- SWELL cavity test result confirmed with very good accuracy.

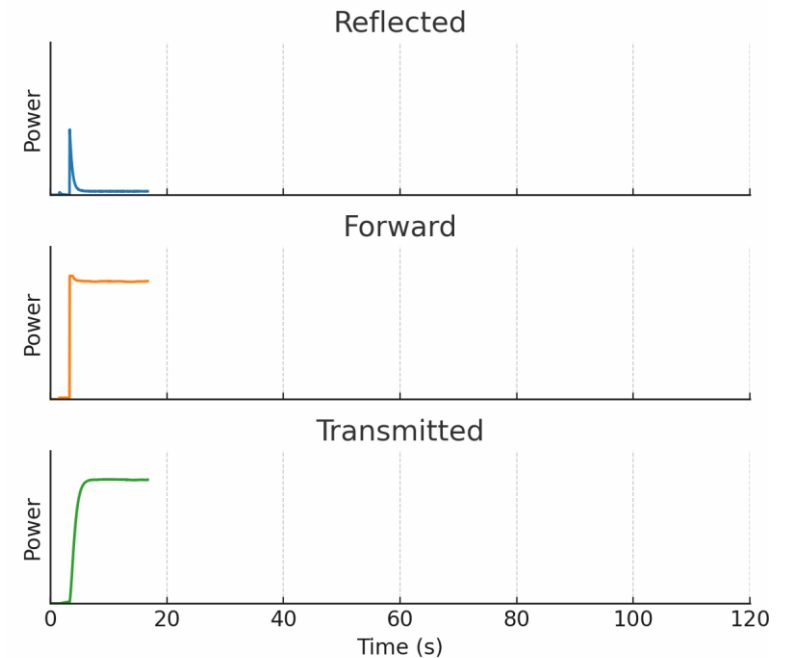
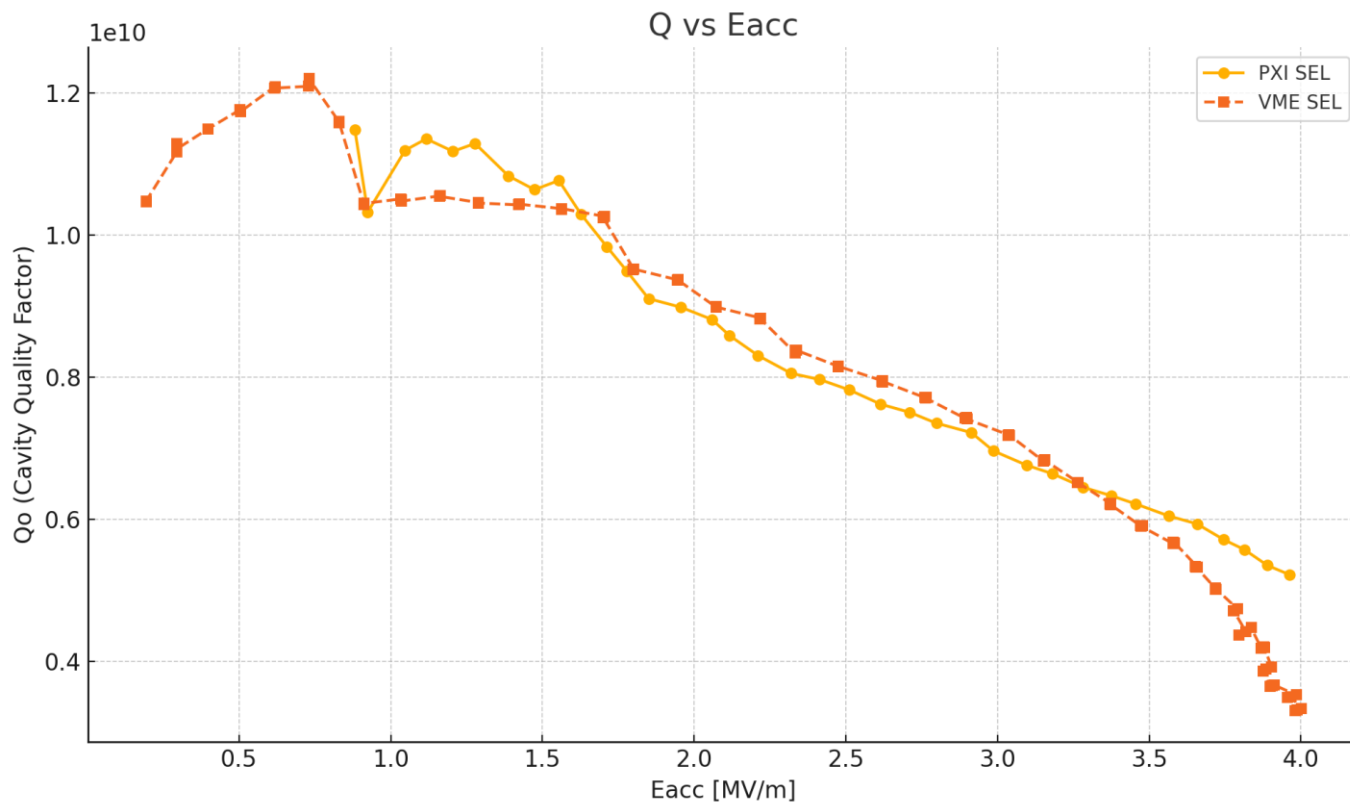

Next steps for SWELL 1.3 GHz cavity

- The improvement obtained by helium processing is a sign that the cavity might be **polluted by particles**. As a reminder the quadrant have been rinsed at low pressure before assembly only.
- Now the proposal is to **perform HPR with the cavity already assembled**. A new cavity support has been designed and fabricated.
- Proposed recipe:
 - 30 bar rinsing,
 - drying by natural evaporation in the clean room,
 - heating of the cavity with UV lamps at ~ 40 deg C, 8 hours once installed in the cryostat.

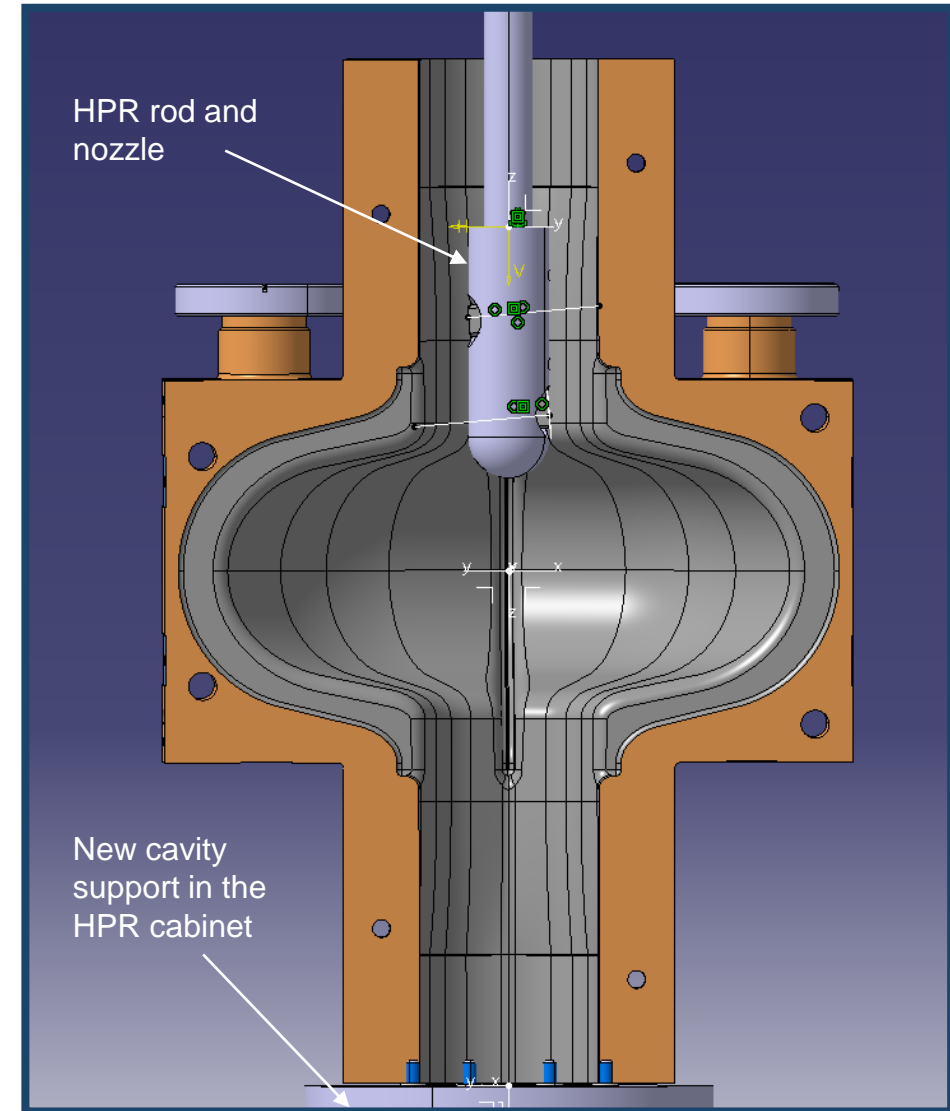

HPR of SWELL cavity

16 May 2025

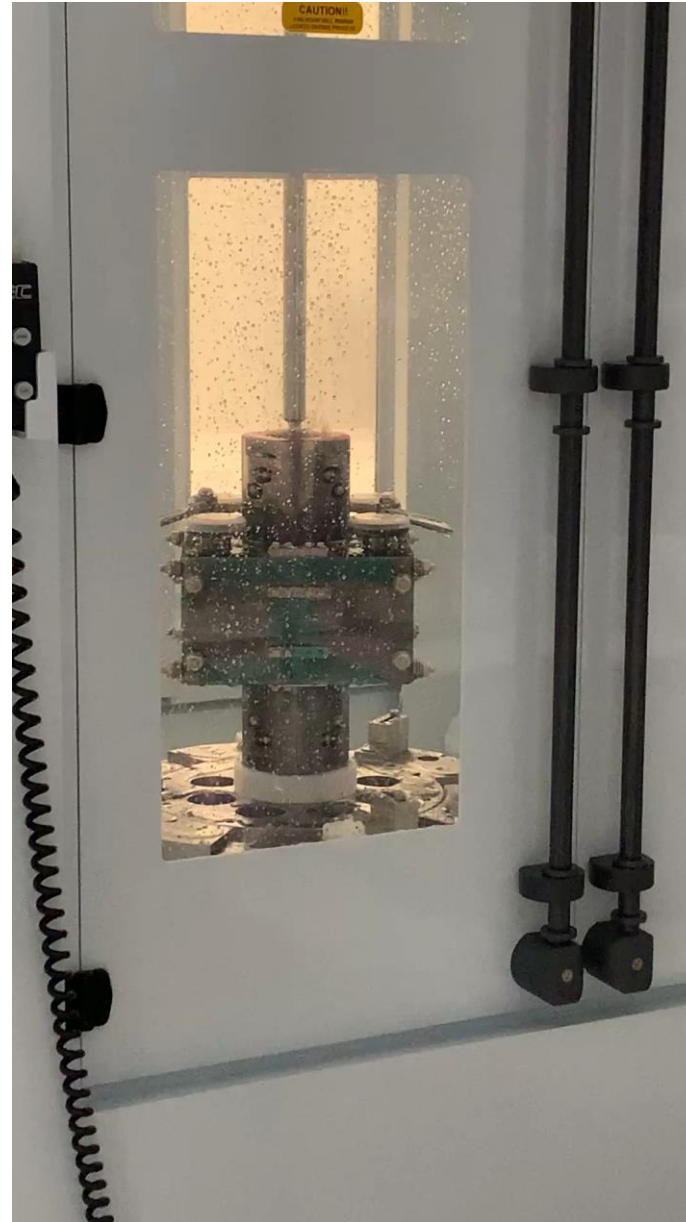
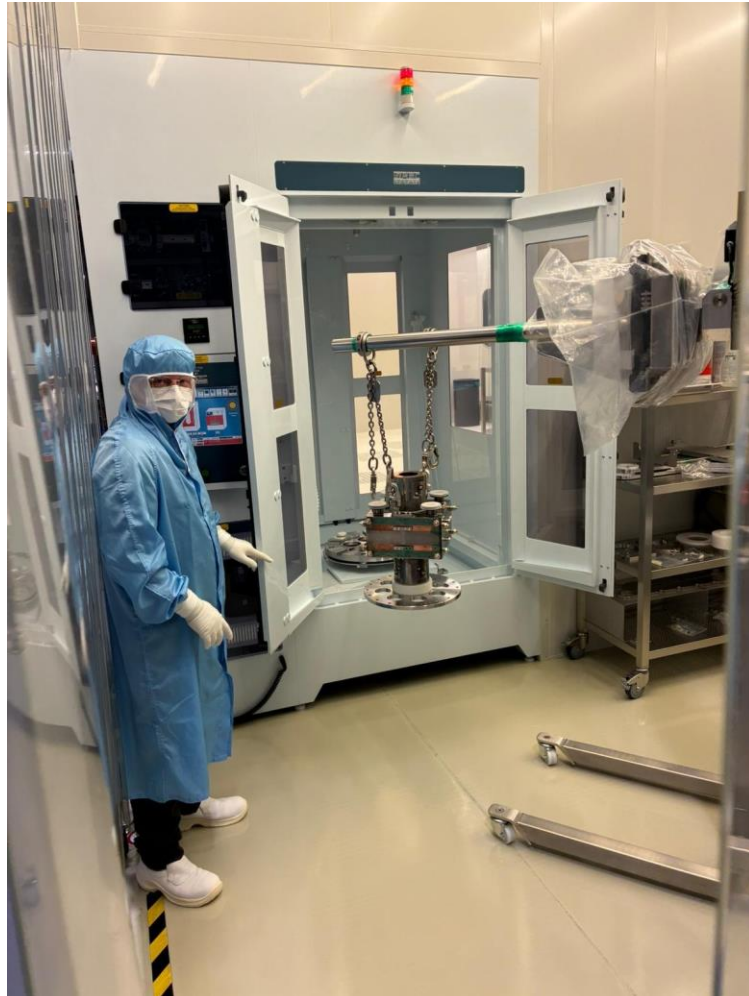

Next steps:

**Installation on the
insert (this week)
and re-test at cold
temperature (June
2025)**

Summary and next steps

- We successfully completed the preliminary clean room preparation and cold testing of two unique Nb/Cu cavities WOW and SWELL developed for the FCC study.
- These prototypes are part of the R&D studies of niobium-on-copper technology for next-generation SRF systems.
- This campaign required niobium thin film re-coating process (SWELL), iteration to optimize the RF coupling for accurate measurements (WOW) and improvement of surface treatment protocols (SWELL).
- These efforts did not allow to reach (yet) the expected the Q_0 and RF voltage specification but encouraging results have already been obtained (surface resistance at low field, sensitivity to ambient magnetic field).
- Additional clean room preparation and cold testing campaigns are being discussed and planned to continue supporting this R&D work.

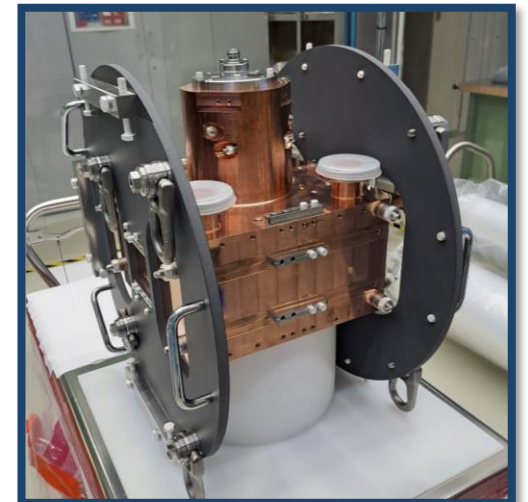
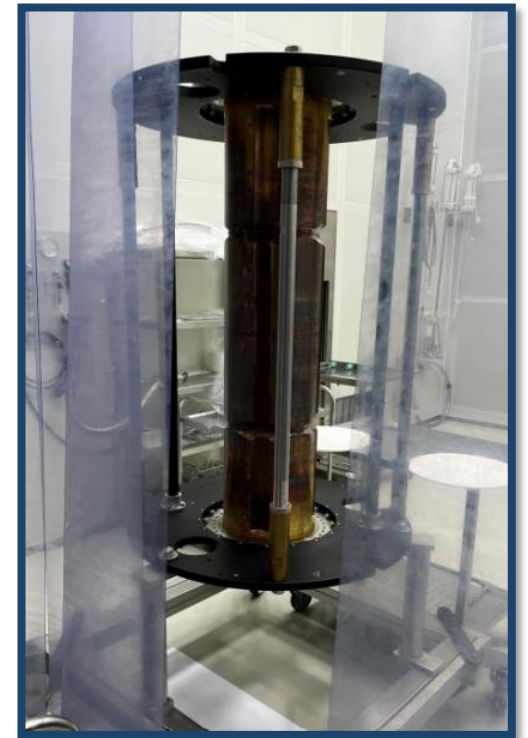



home.cern

WOW cavity - RF conditioning (multipacting, ...)

Visible during phase scan

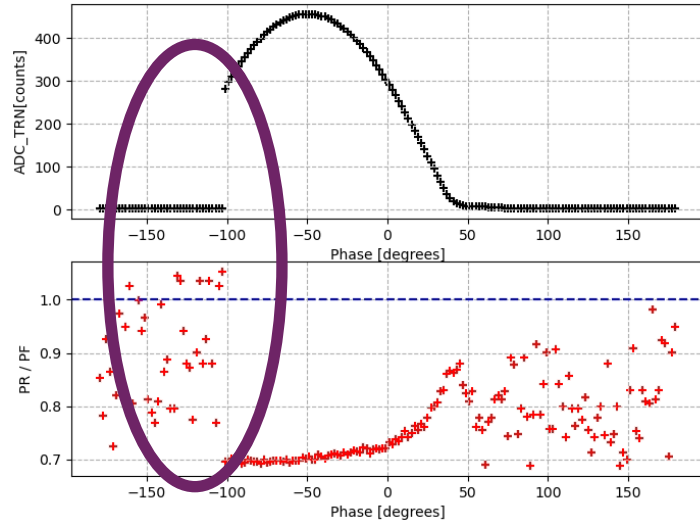

before

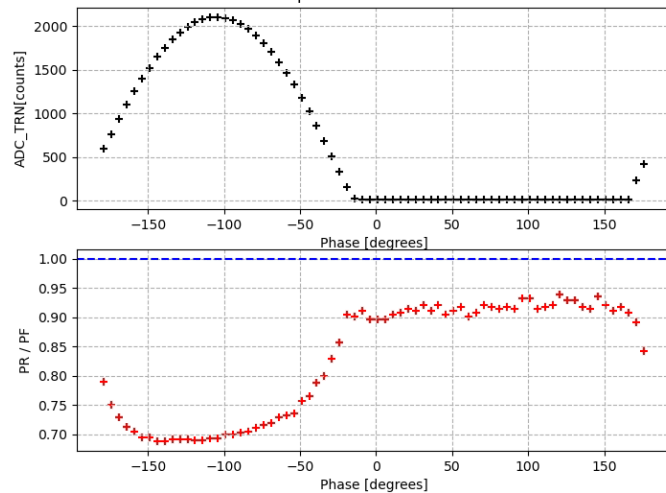

after

Missing pulses

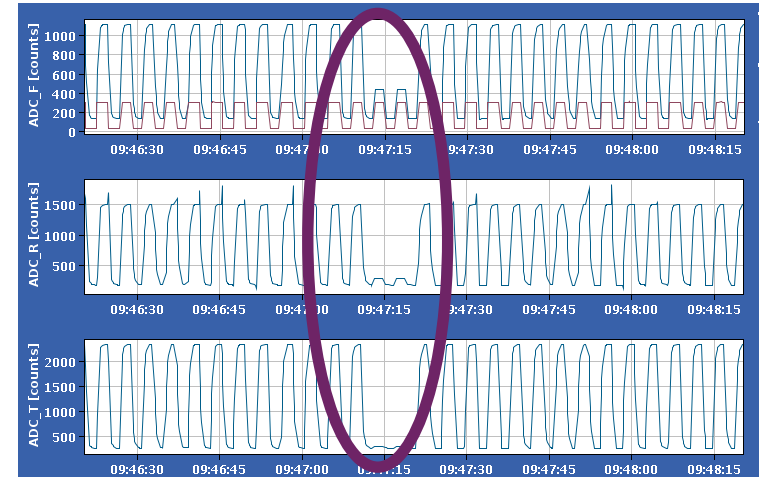

WOW measurement principle with digital Self Excited Loop (SEL)

RF cables calibration (attenuation factors A) and Analog Digital Converters (ADC) calibration factor C

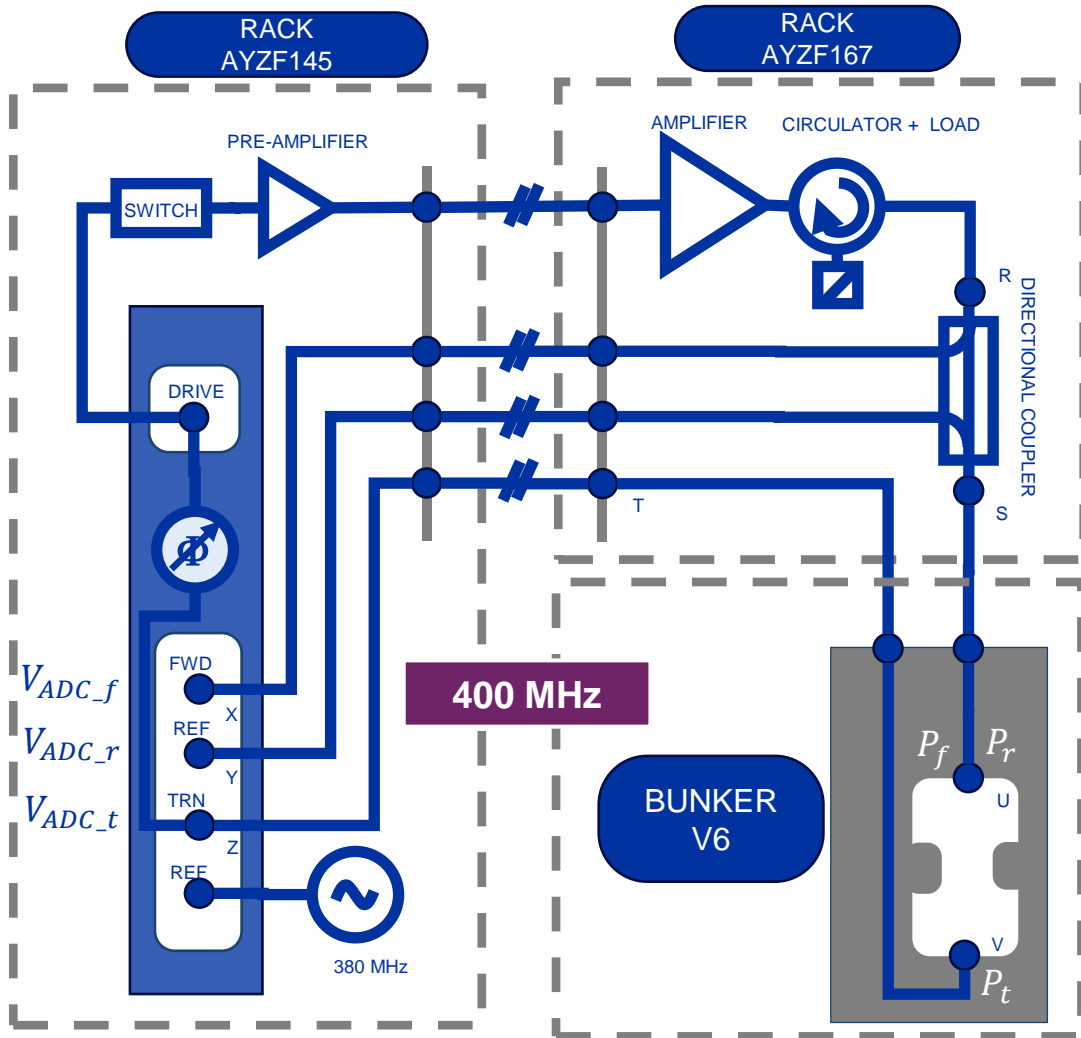

$$A_f = RX - RS - SU$$

$$A_r = SU + SY$$

$$A_t = TV + TZ$$

$$C_f = \frac{V_{ADC_f}^2}{P_f} \quad C_r = \frac{V_{ADC_r}^2}{P_r} \quad C_t = \frac{V_{ADC_t}^2}{P_t}$$

Measurement of cavity frequency, decay time and RF forward, reflected and transmitted power at cavity location

$$P_f = \frac{V_{ADC_f}^2}{C_f} \cdot 10^{A_f/10}$$

$$P_r = \frac{V_{ADC_r}^2}{C_r} \cdot 10^{A_r/10}$$

$$P_t = \frac{V_{ADC_t}^2}{C_t} \cdot 10^{A_t/10}$$

$$P_c = P_f - P_r - P_t$$

$$\beta_t = \frac{P_t}{P_c}$$

$$\beta_i = \frac{1 \mp \sqrt{P_r/P_f}}{1 \pm \sqrt{P_r/P_f}}$$

$$\omega = 2\pi \cdot F$$

$$Q_L = \omega \cdot \tau$$

$$Q_0 = Q_L(1 + \beta_i + \beta_t)$$

$$Q_i = \frac{Q_0}{\beta_i} \quad Q_t = Q_0 \frac{P_c}{P_t}$$

$$Q_o = Q_t \frac{P_t}{P_c} \quad U = \frac{Q_t \cdot P_t}{\omega} = K \cdot P_t$$

$$V_t = \sqrt{R/Q \cdot \omega \cdot U} = \sqrt{U/\kappaappa}$$

Rs(Bpk) sensitivity to ambient B field

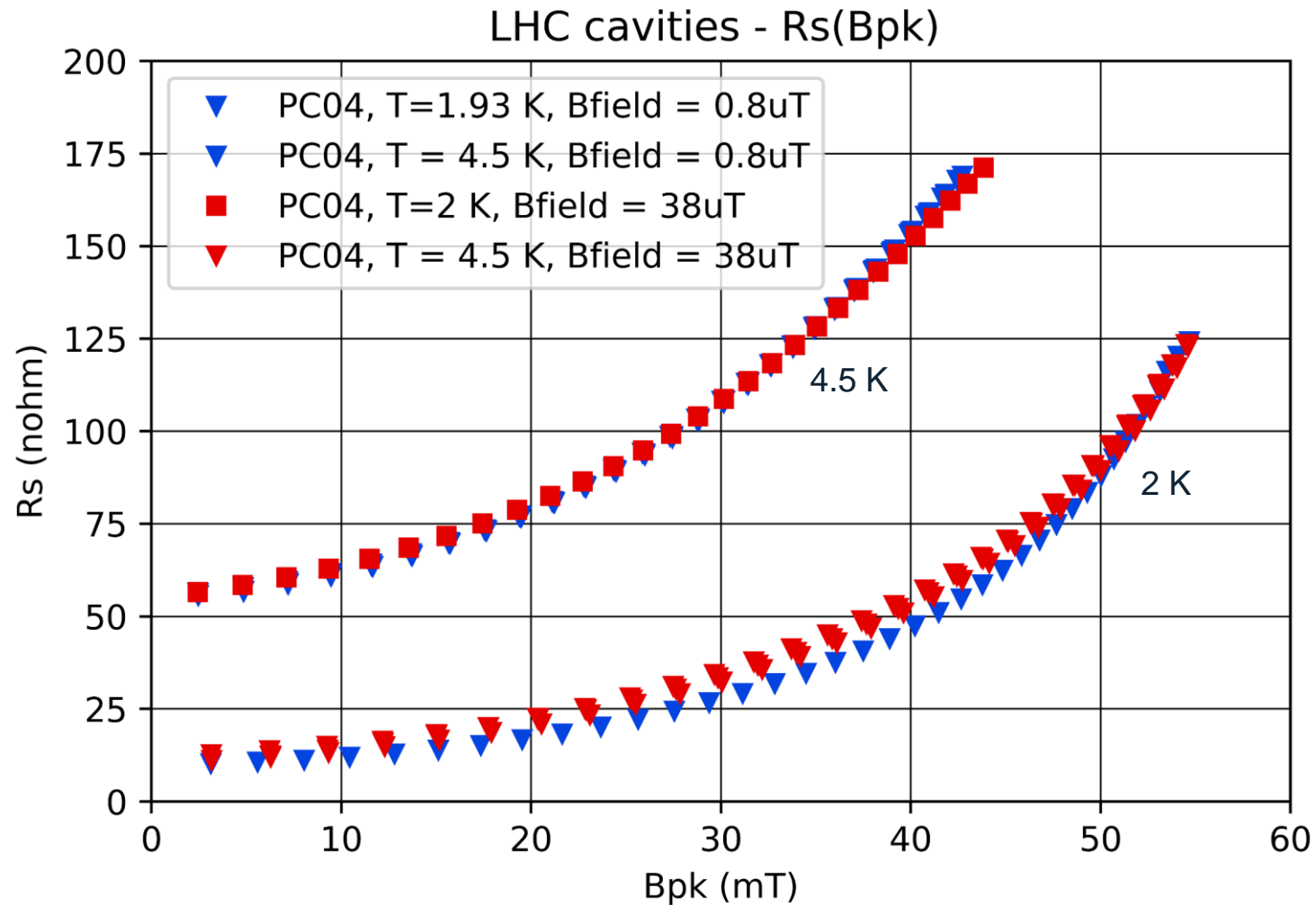

400 MHz SWELL RF parameters

| Parameters | FCC 2-cell with two hook couplers | FCC 2-cell SWELL |
|------------------------|---|---------------------|
| F (MHz) | 400.79 | 400.79 |
| R/Q linac (Ω) | 182.7 | 181 |
| Lacc (mm) | 749 | 749 |
| Epk/Eacc | 2.0 | 2.5 |
| Bpk/Eacc (mT/(MV/m)) | 5.33 | 6.0 |
| Epk @ 13 MV/m (MV/m) | 26 | 32.5 |
| Bpk @ 13 MV/m (mT) | 69.3 | 78 |
| G (Ω) | 232.7 | 227.85 |

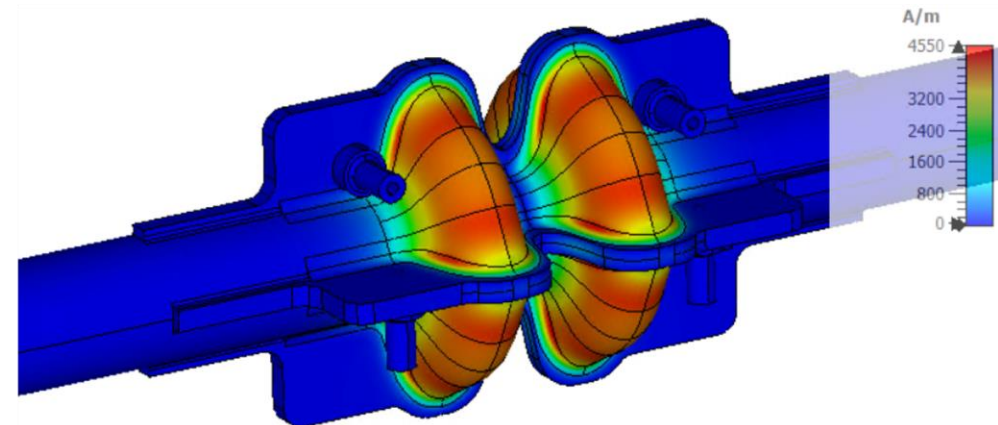
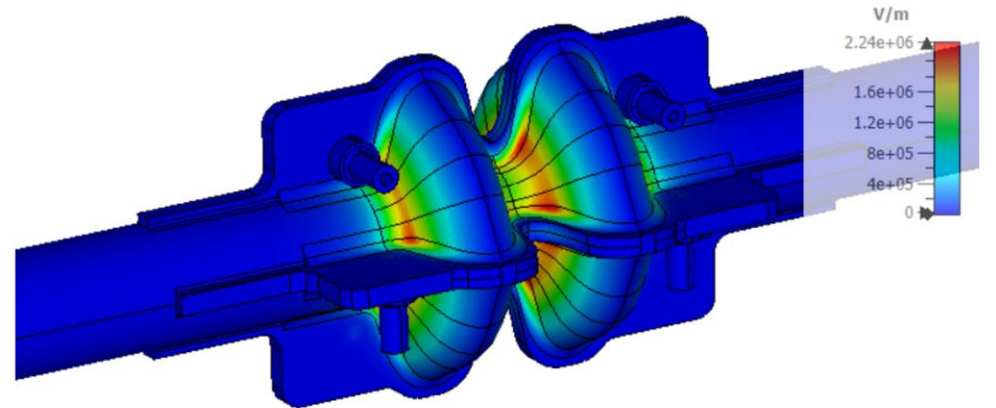

SWELL measurement principle with digital Self Excited Loop (SEL)

RF cables calibration (attenuation factors A) and Analog Digital Converters (ADC) calibration factor C

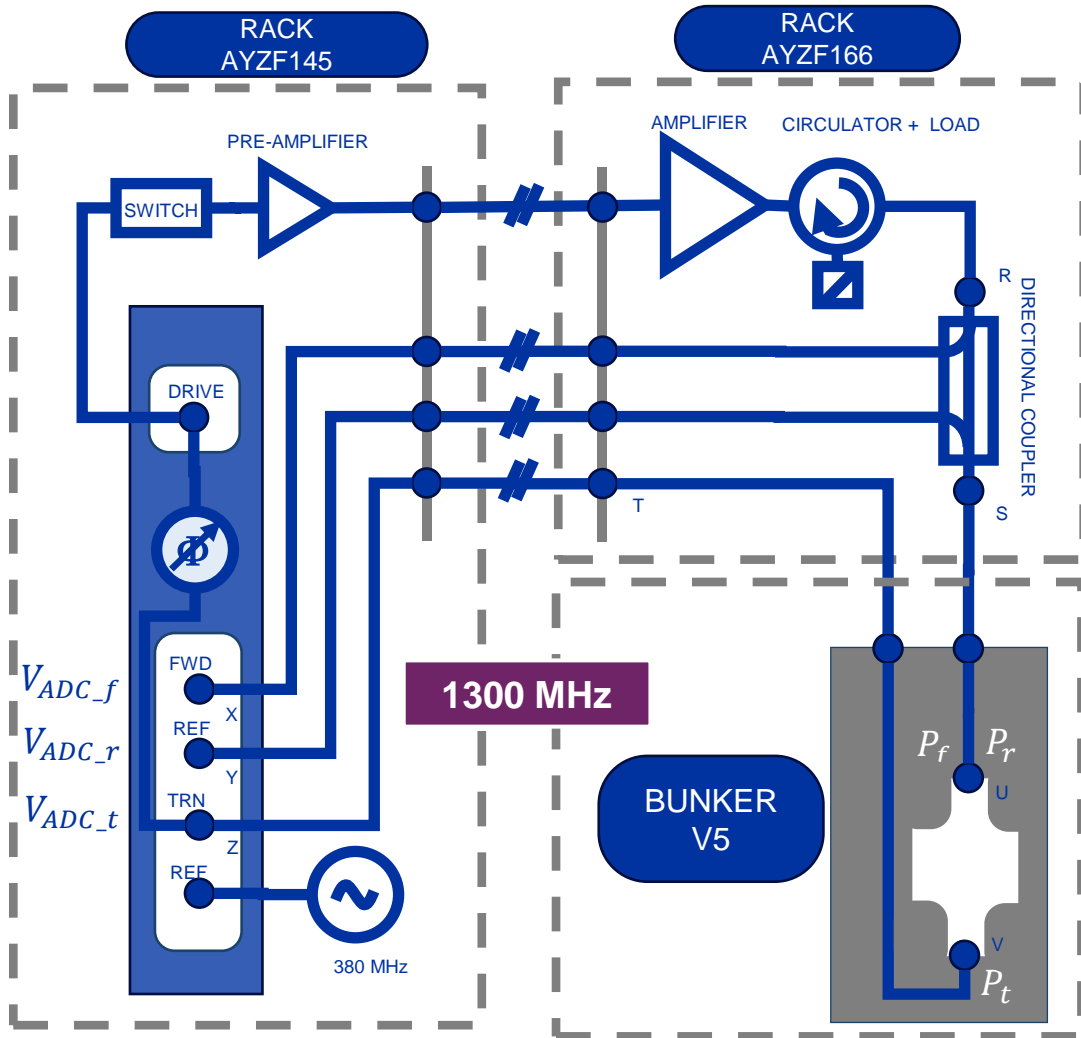

$$A_f = RX - RS - SU$$

$$A_r = SU + SY$$

$$A_t = TV + TZ$$

$$C_f = \frac{V_{ADC_f}^2}{P_f} \quad C_r = \frac{V_{ADC_r}^2}{P_r} \quad C_t = \frac{V_{ADC_t}^2}{P_t}$$

Measurement of cavity frequency, decay time and RF forward, reflected and transmitted power at cavity location

$$P_f = \frac{V_{ADC_f}^2}{C_f} \cdot 10^{A_f/10}$$

$$P_r = \frac{V_{ADC_r}^2}{C_r} \cdot 10^{A_r/10}$$

$$P_t = \frac{V_{ADC_t}^2}{C_t} \cdot 10^{A_t/10}$$

$$P_c = P_f - P_r - P_t$$

$$\beta_t = \frac{P_t}{P_c}$$

$$\beta_i = \frac{1 \mp \sqrt{P_r/P_f}}{1 \pm \sqrt{P_r/P_f}}$$

$$\omega = 2\pi \cdot F$$

$$Q_L = \omega \cdot \tau$$

$$Q_0 = Q_L(1 + \beta_i + \beta_t)$$

$$Q_i = \frac{Q_0}{\beta_i} \quad Q_t = Q_0 \frac{P_c}{P_t}$$

$$Q_0 = Q_t \frac{P_t}{P_c} \quad U = \frac{Q_t \cdot P_t}{\omega} = K \cdot P_t$$

$$E_{acc} = \frac{1}{L_{acc}} \sqrt{R/Q \cdot \omega \cdot U} = \sqrt{U/\kappaappa}$$

RF coupling of antennas

DESIGN

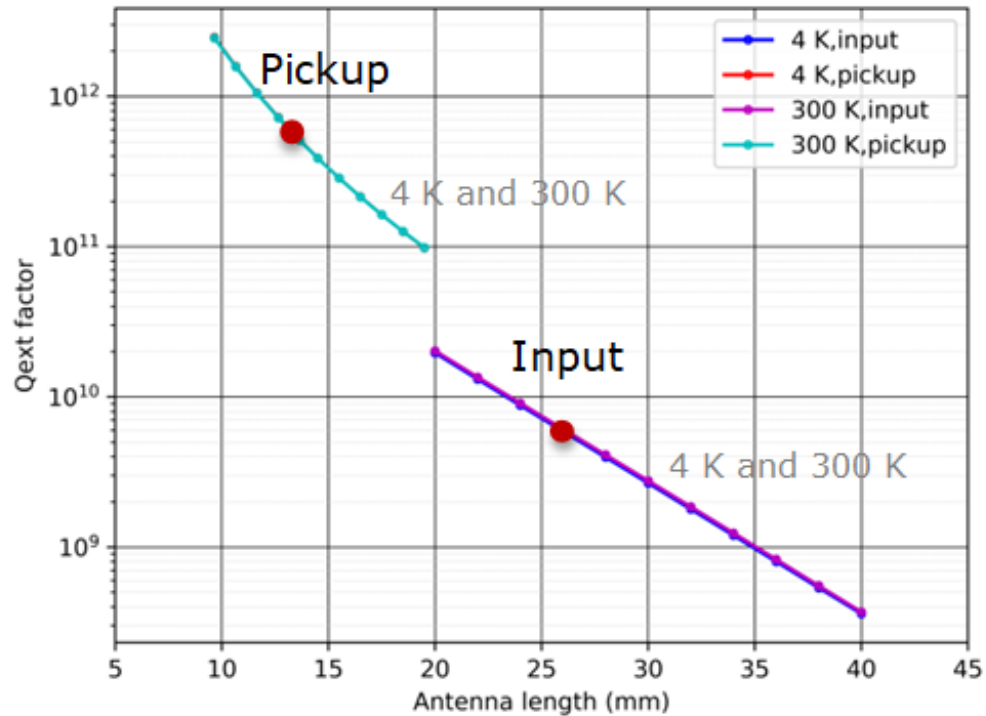

| | External Q value | Antenna length (mm) |
|-------|--------------------|---------------------|
| Q_i | 6×10^9 | 26 |
| Q_t | 6×10^{11} | 13 |

MEASUREMENTS

$$Q_i = 7.65 \times 10^9$$

$$Q_t = 6.14 \times 10^{11}$$

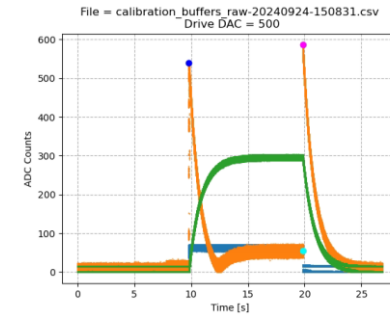

$$Q_0 = 9 \times 10^9$$

overcoupled

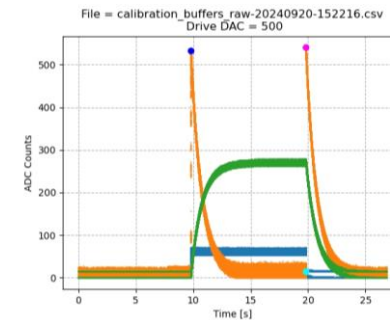

$$Q_0 = 7.7 \times 10^9$$

critically coupled

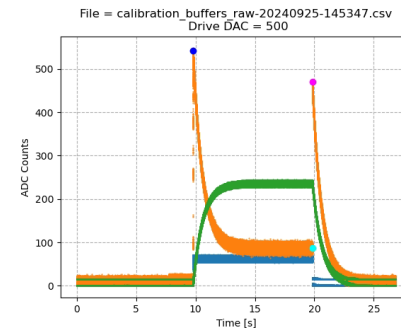

$$Q_0 = 6 \times 10^9$$

undercoupled

orange : reflected signal

Magnetic field measurement in V5

| I coil1 (mA) dipole | I coil2 (mA) solenoid | Bx (uT) | By (uT) | Bz (uT) |
|---------------------|-----------------------|------------|-----------|-------------|
| 0 | 0 | | | 46.1 |
| 0 | -630 | | | 0 |
| 0 | -630 | | | 0 * |
| 1900 | -630 | | | -0.6 |
| 0 | 0 | 10 | 47.8 | |
| 0 | -630 | 8.3 | 47 | |
| 1900 | 0 | -24.1 | 0 | |
| 1900 | -630 | -26 | -8 | |

* with +/- 10 cm lateral offset

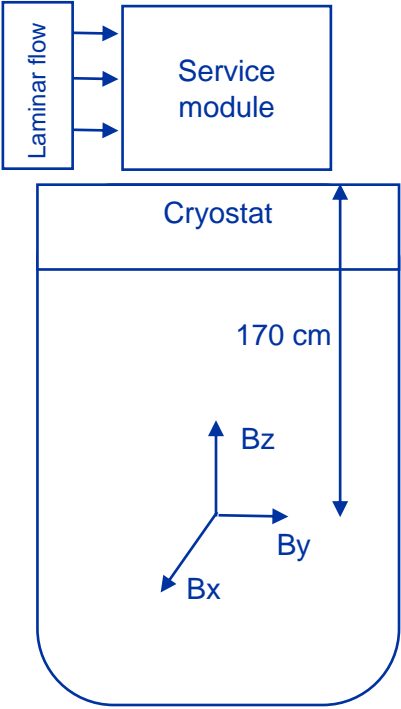

Magnetic field probe

Development plan for SWELL cavity

