

Hybrid REBCO-Cu coating for the FCC beam screen to achieve low surface impedance and high magnetic field homogeneity



Joffre Gutierrez Royo



The Beam Screen

- Shields Magnets from **SR**
- Has **low beam impedance**
- Allows **high field quality**
- Is **thermomechanically robust**
- **Other** (vacuum, SEY...)

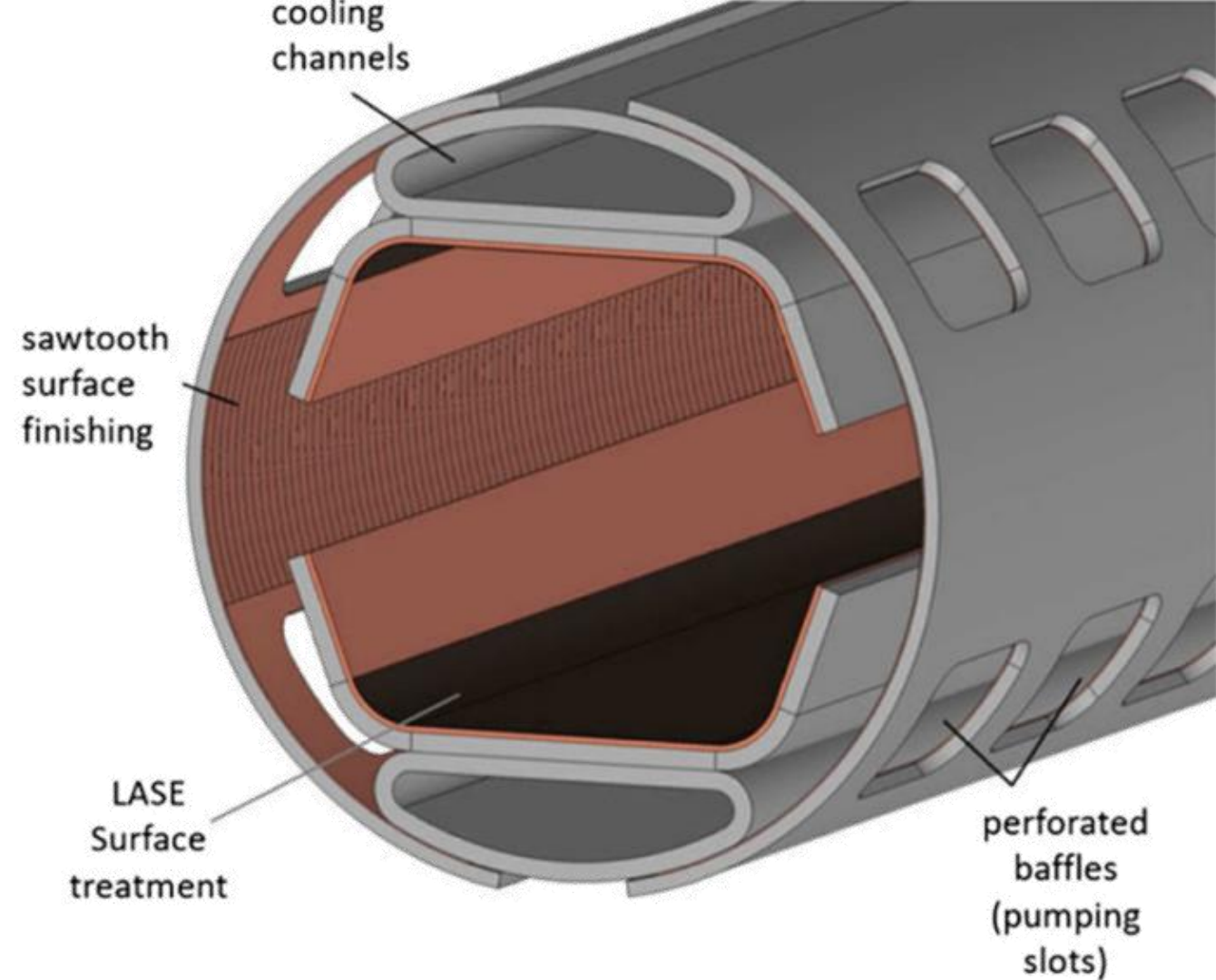

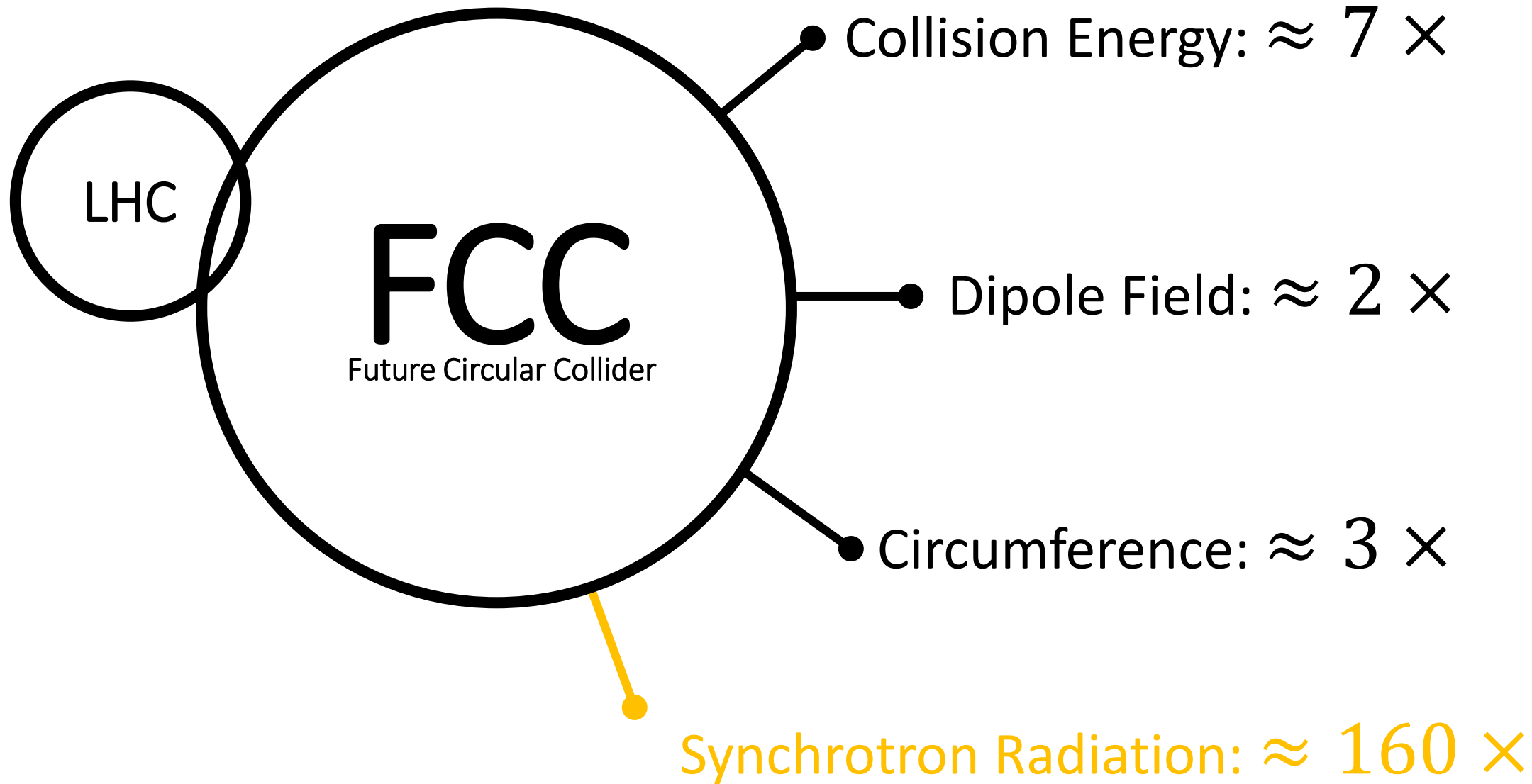

Cooling Power

- No Beam Screen

> 2 GW

- Beam Screen at 5 – 20 K

≈ 500 MW

- Beam Screen at 40 – 60 K

≈ 100 MW

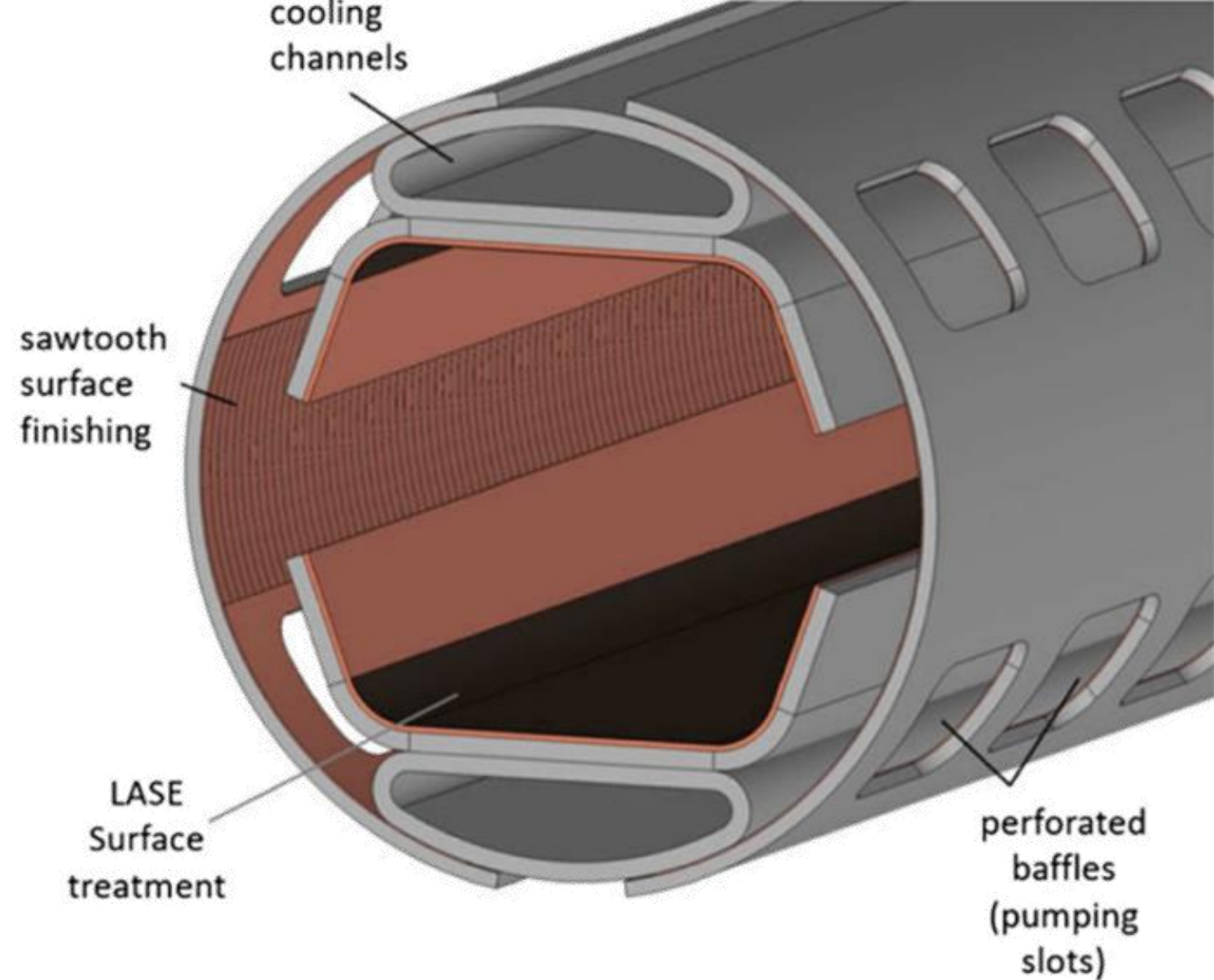

Is there a better coating than copper at ≈ 50 K?

The Hybrid REBCO – Cu coating

- Shields Magnets from **SR**
- Has **low beam impedance**
- Allows **high field quality**
- Is **thermomechanically robust**
- **Other** (vacuum, SEY...)

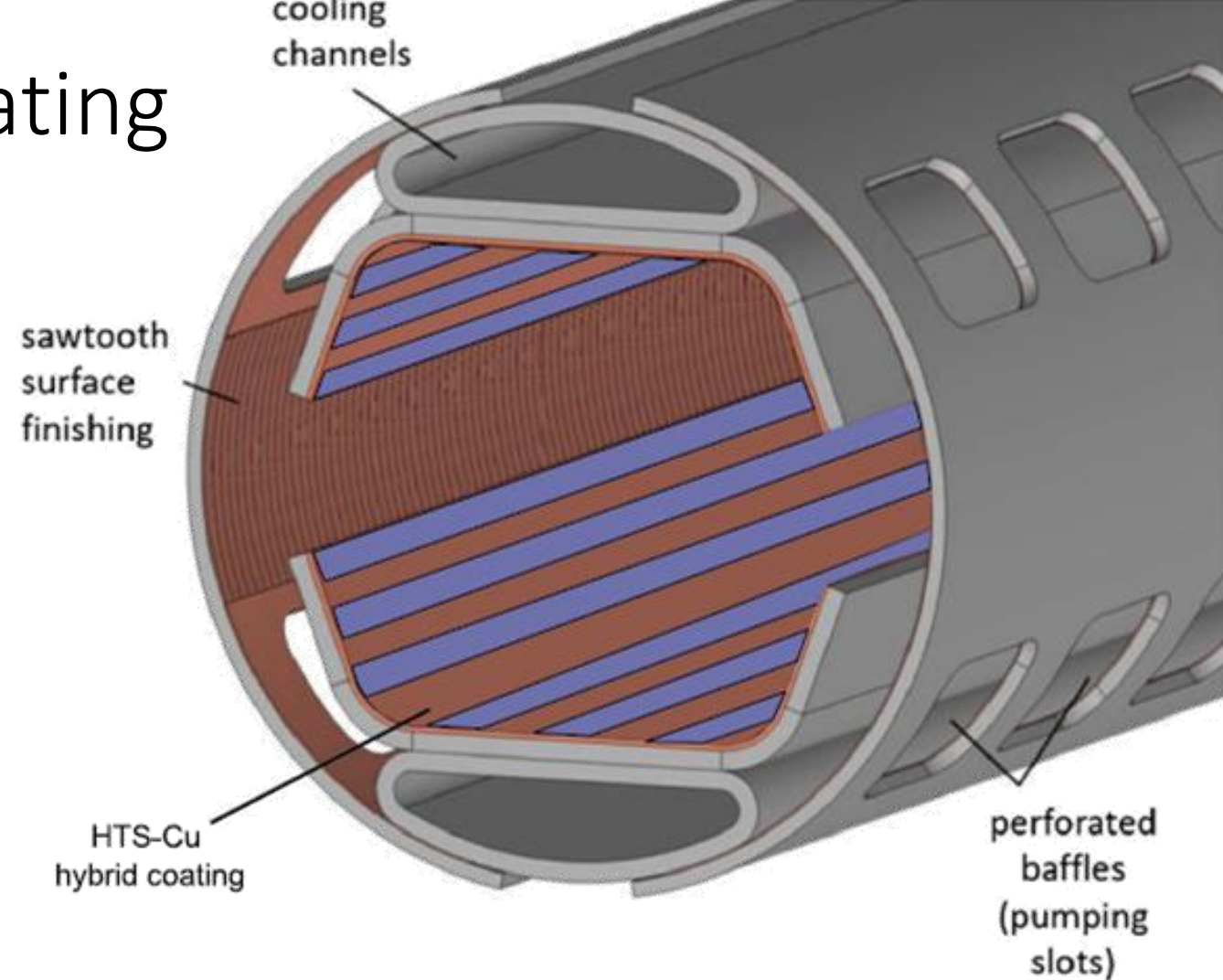

Outline

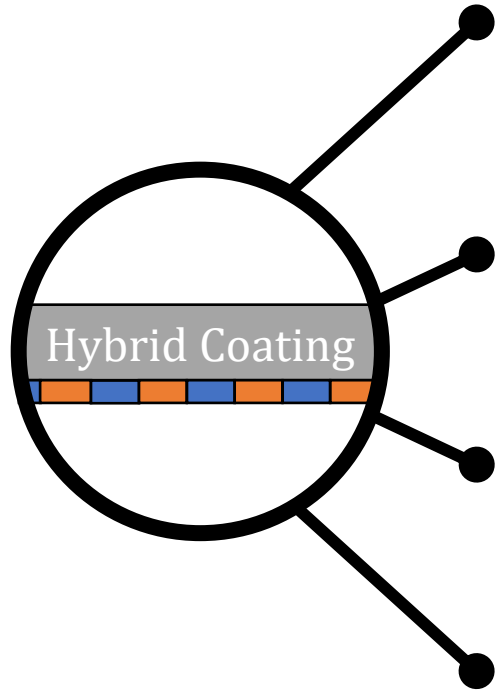

REBCO surface impedance under high magnetic fields

Simulations of the magnetic field homogeneity in the hybrid coated BS

Simulations of the thermomechanical robustness of the hybrid coated BS

Other considerations

Outline

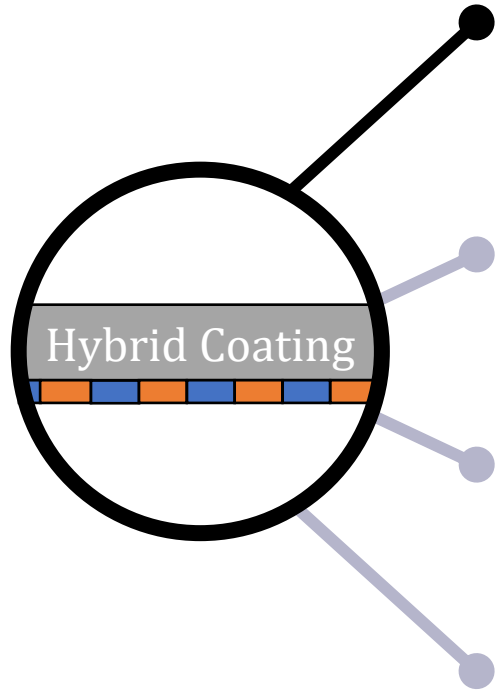

REBCO surface impedance under high magnetic fields

Simulations of the magnetic field homogeneity in the hybrid coated BS

Simulations of the thermomechanical robustness of the hybrid coated BS

Other considerations

REBCO CCs have lower R_s than Cu at similar FCC-hh operating conditions

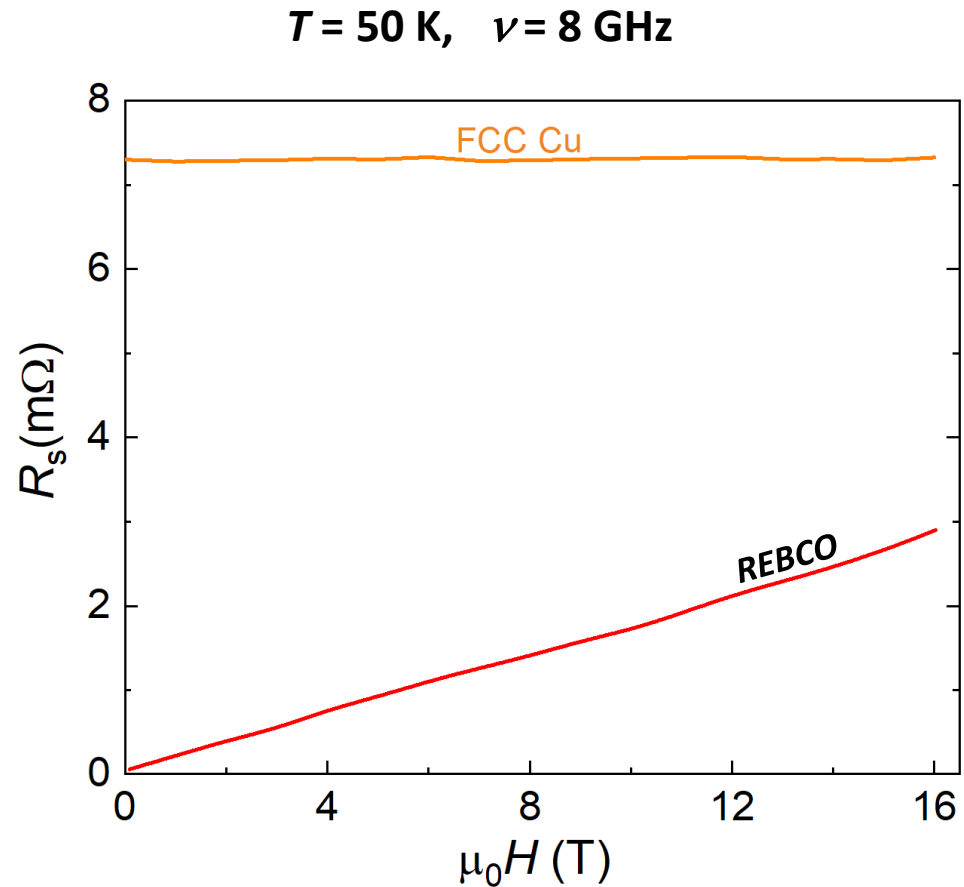

T. Puig et al, Supercond. Sci. Technol. 32 (2019)

REBCO CCs have lower R_s than Cu at similar FCC-hh operating conditions

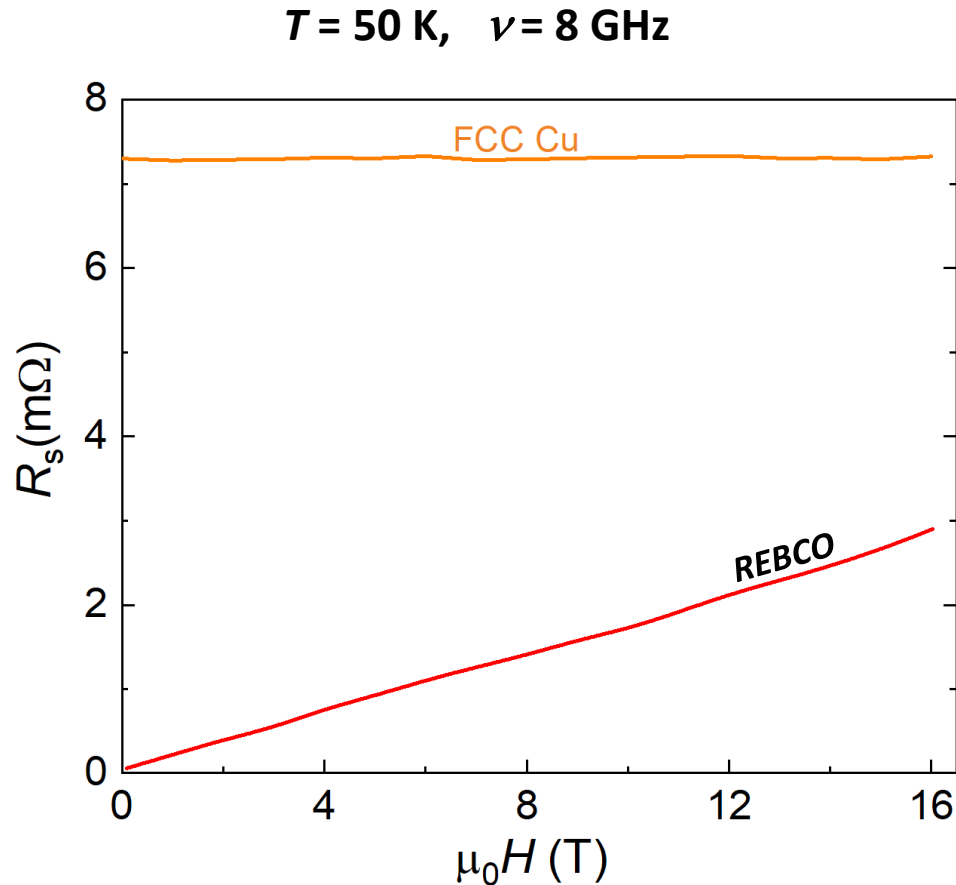

T. Puig et al, *Supercond. Sci. Technol.* **32** (2019)

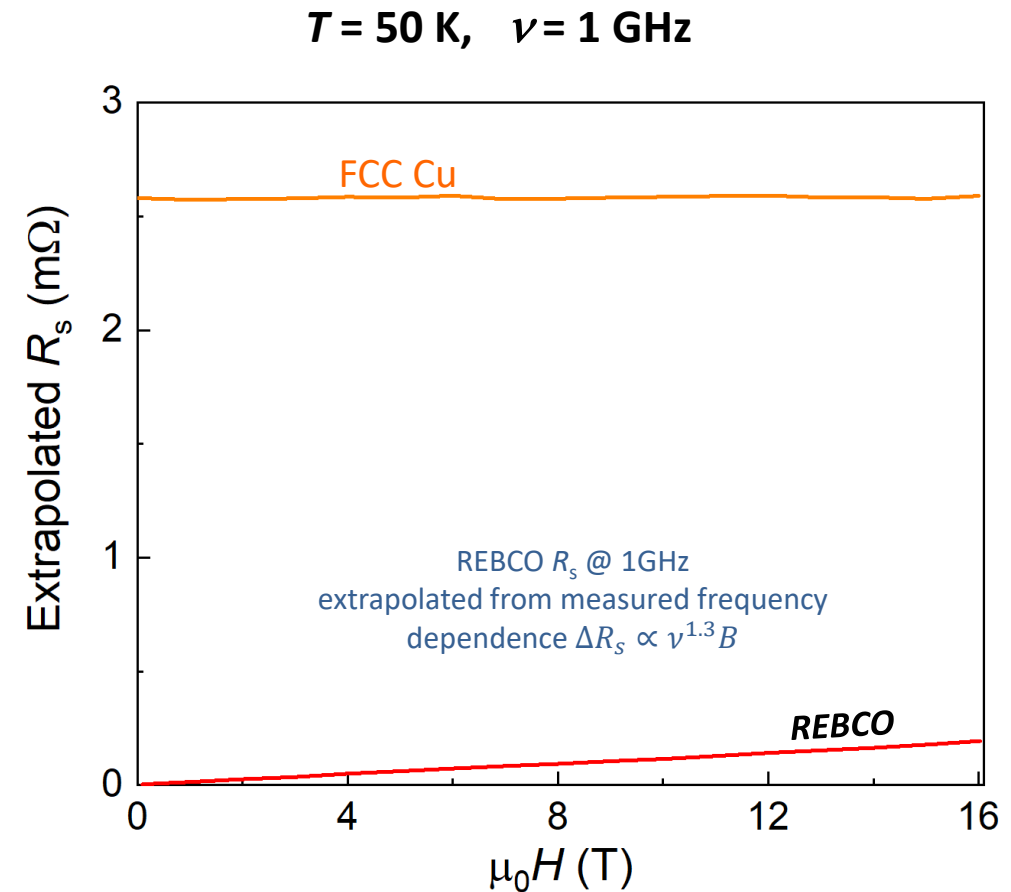

A. Romanov, et al. *Scientific reports* **10** (2020)

N. Tagdulang, Ph.D. Thesis, UPC (2024)

The lower the operating frequency, the larger the benefit from using REBCO

Outline

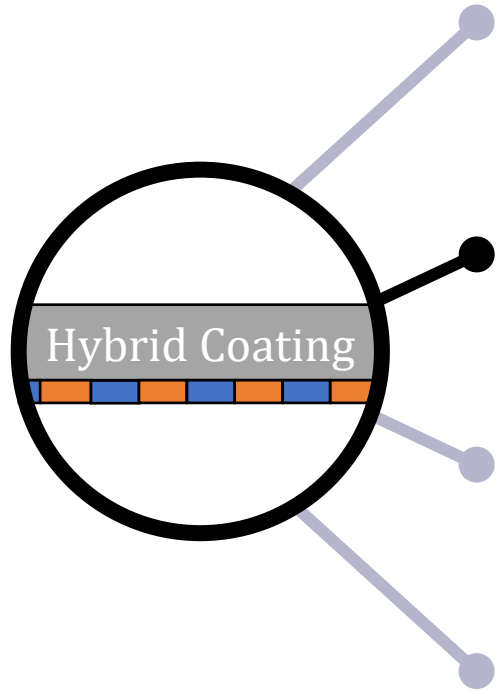

REBCO surface impedance under high magnetic fields

Simulations of the magnetic field homogeneity in the hybrid coated BS

Simulations of the thermomechanical robustness of the hybrid coated BS

Other considerations

Hybrid coating covering with REBCO 73% of the BS surface retains dipole field homogeneity

Proposed geometry considering dipole corrections and commercially available widths

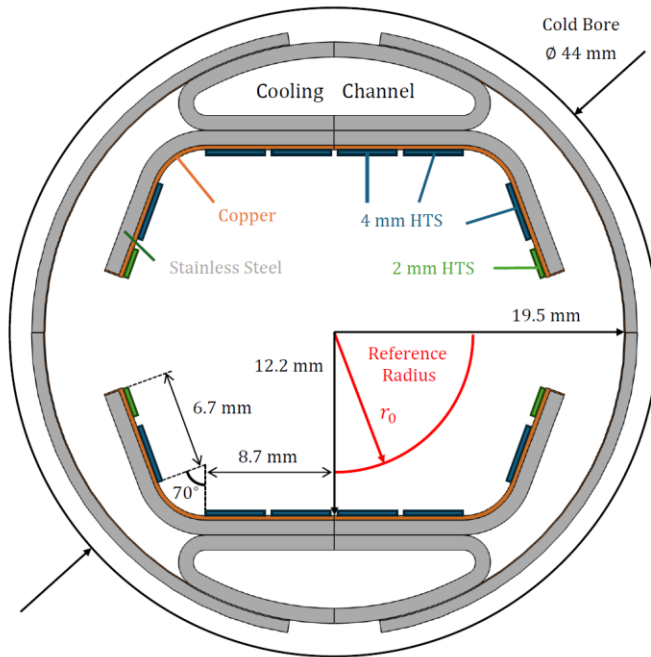

$$\eta(t) = \max_{r=r_0} \frac{|H(r, \phi, t) - H_{ex}(t)|}{|H_{ex}(t)|} = \max_{r=r_0} \frac{\Delta H(r, \phi, t)}{H_{ex}(t)}$$

Harmonics relative magnetic field disturbance

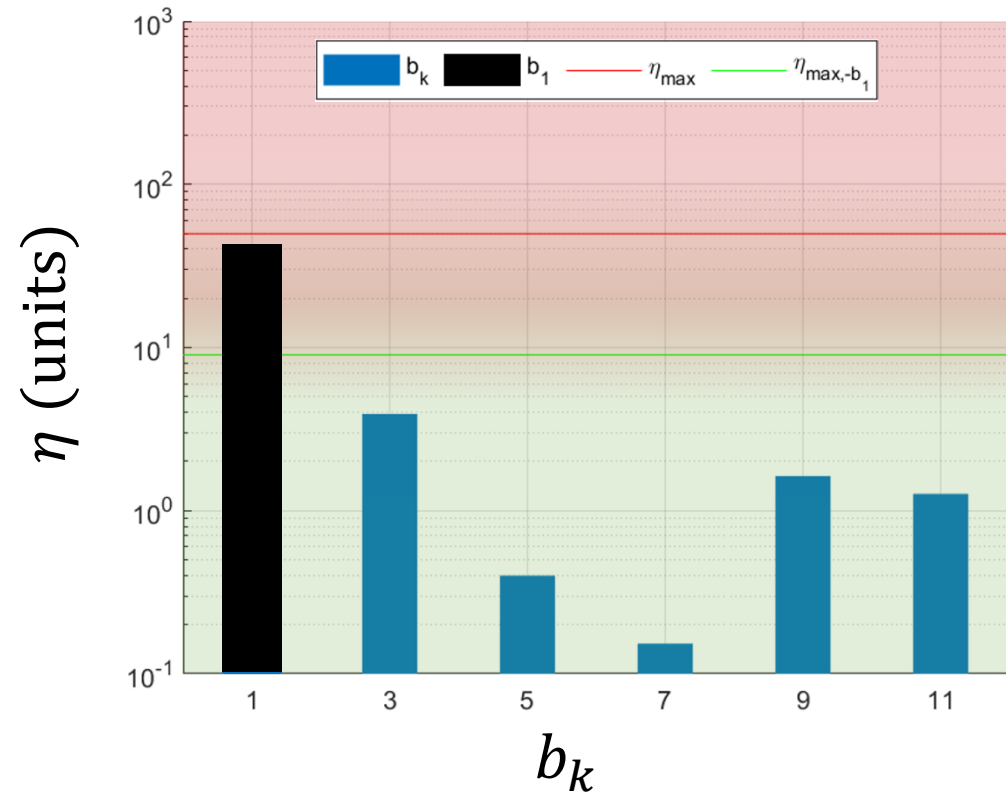

FCC limit a few units are desired

*The hybrid coating for the BS dipole segments
is not suitable for the quadrupole segments*

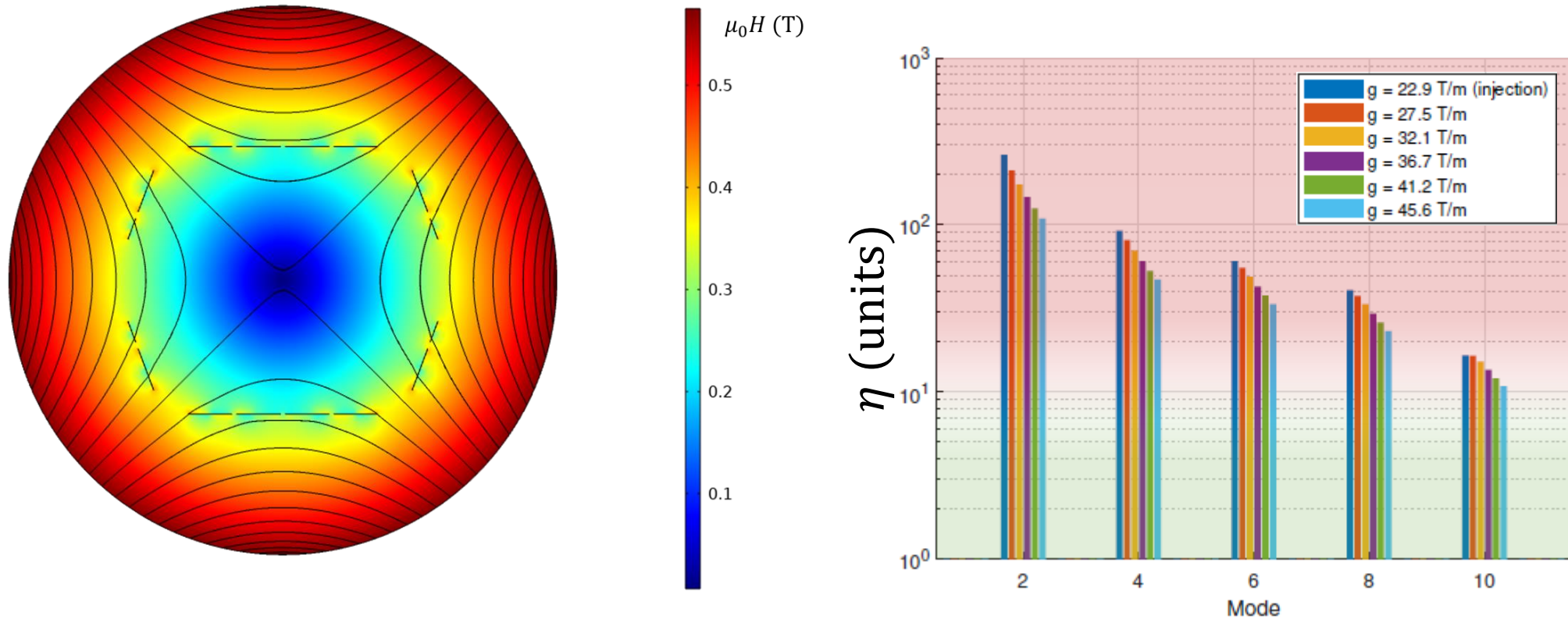

Harmonics in the range of 100s in a quadrupole field

A more segmented geometry is needed for the quadrupole segments

$n = 08$

$n = 04$

$\mu_0 H$ (T)

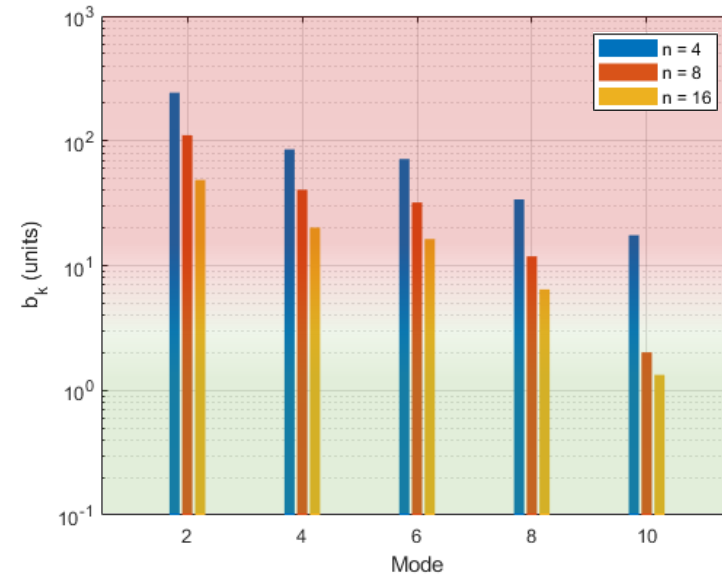
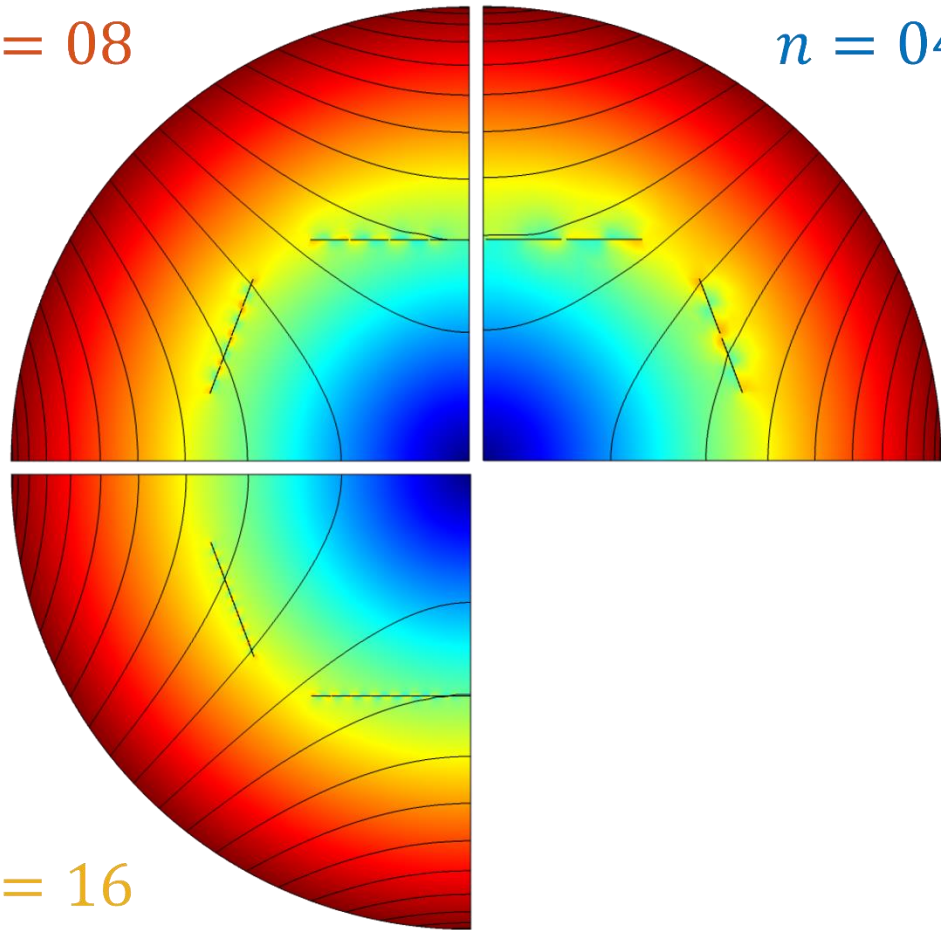

$n = 16$

A more segmented geometry is needed for the quadrupole segments

$n = 08$

$n = 04$

$\mu_0 H$ (T)

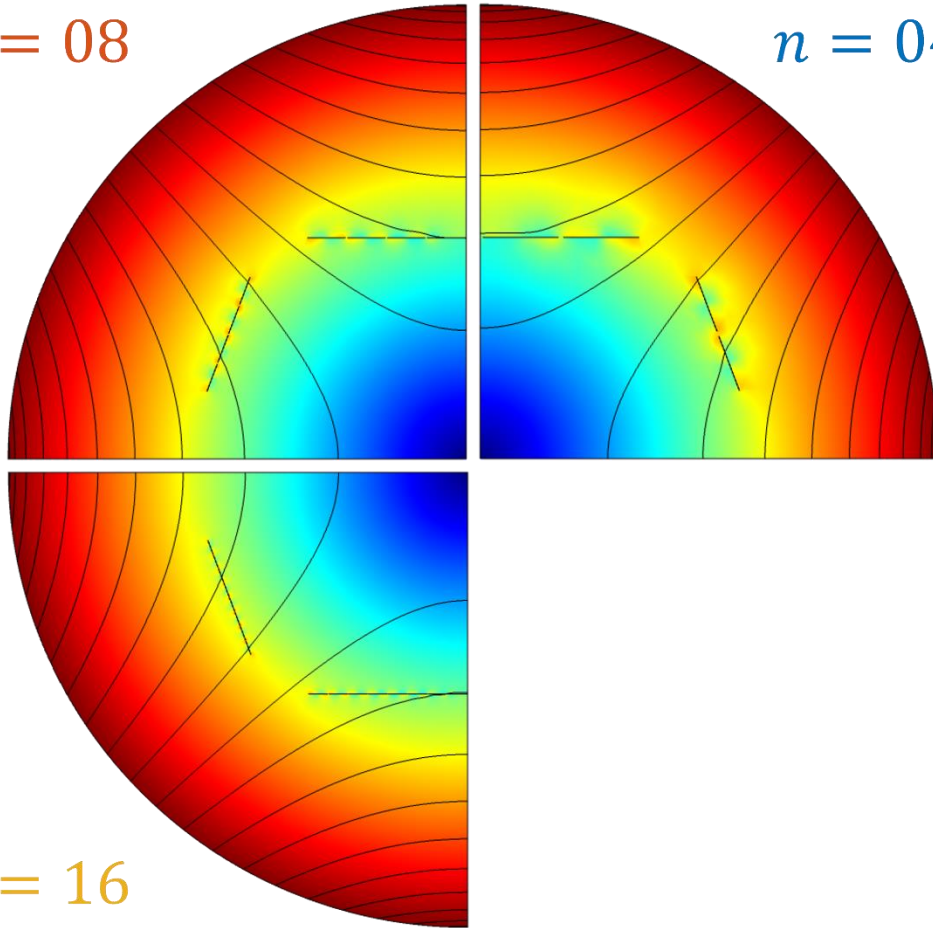

$n = 16$

G T Telles et al (submitted)

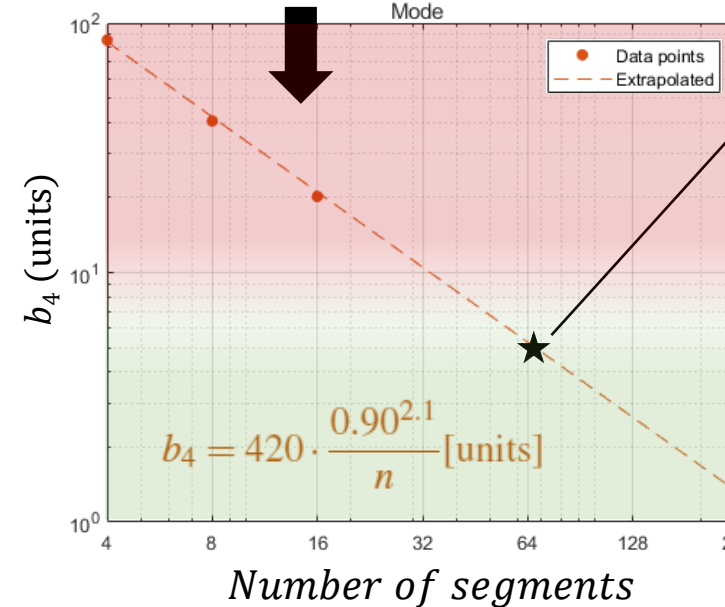
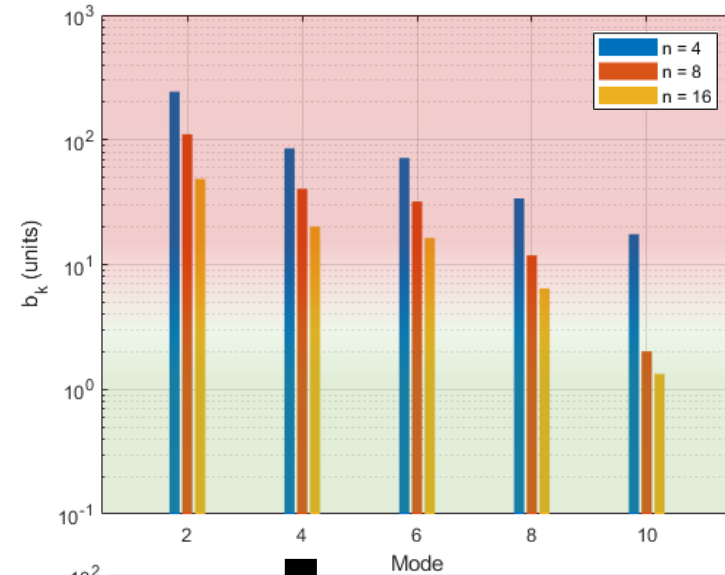

Number of segments

Outline

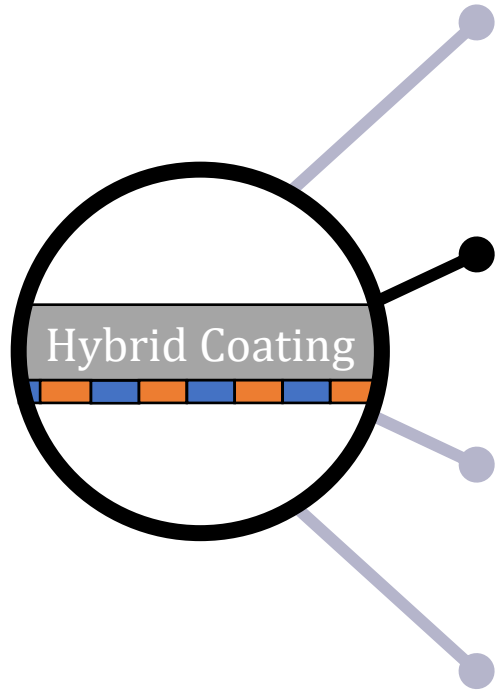

REBCO surface impedance under high magnetic fields

Simulations of the magnetic field homogeneity in the hybrid coated BS

Simulations of the thermomechanical robustness of the hybrid coated BS

Other considerations

Thermal analysis shows no significant shifts in temperature

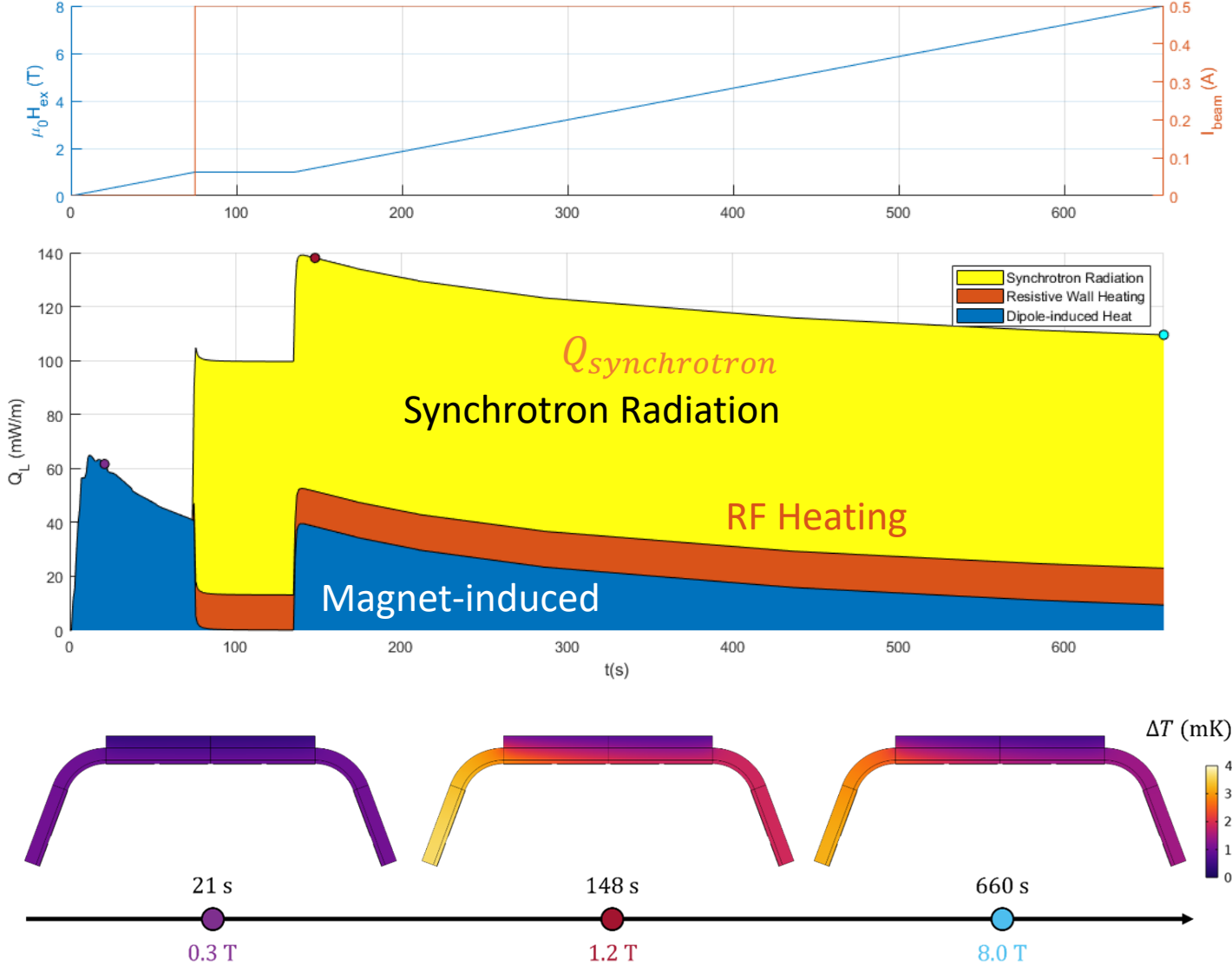

Mechanical analysis shows small induced stresses and deformation

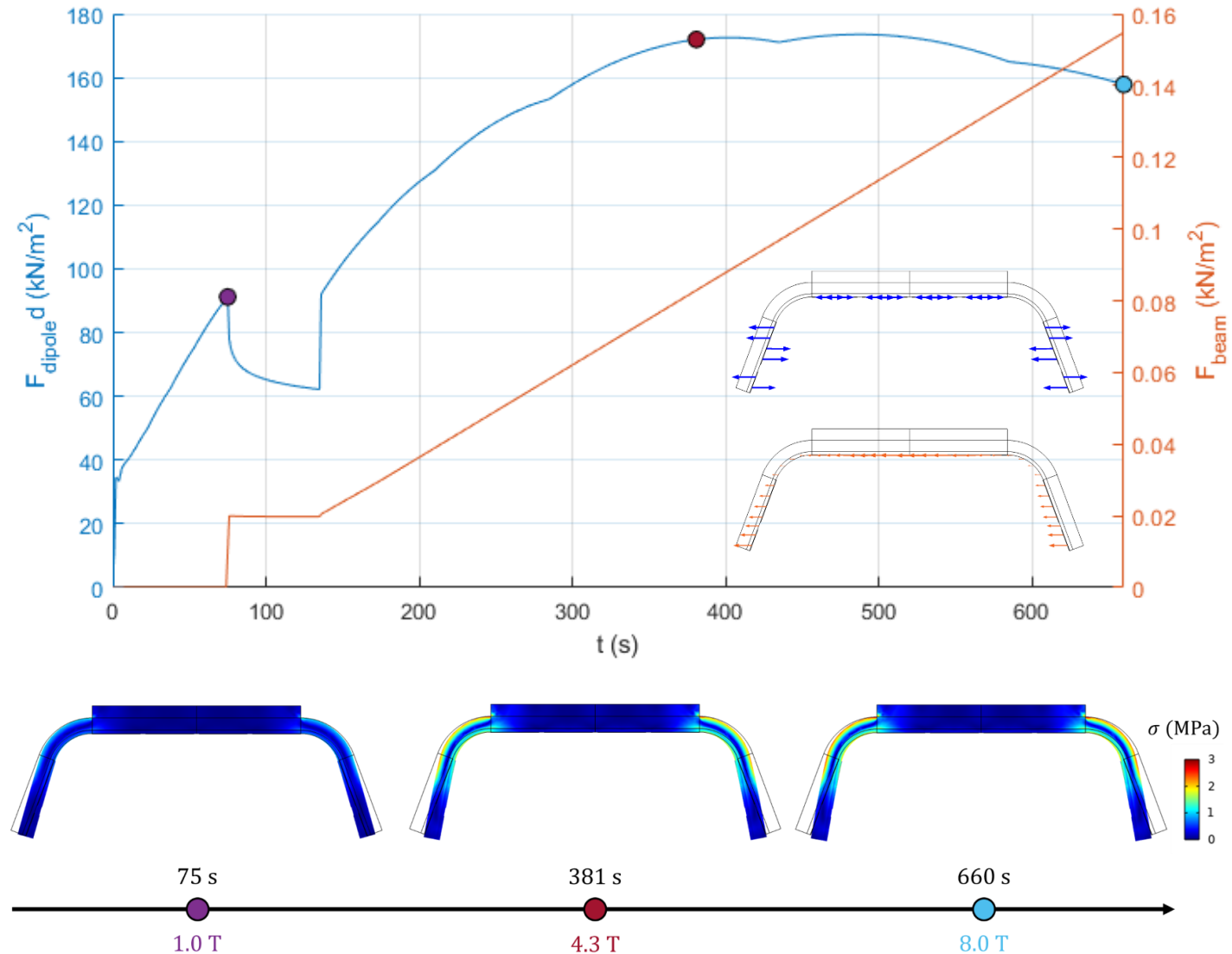

Mechanical analysis shows small induced stresses and deformation even in the event of a dipole quench

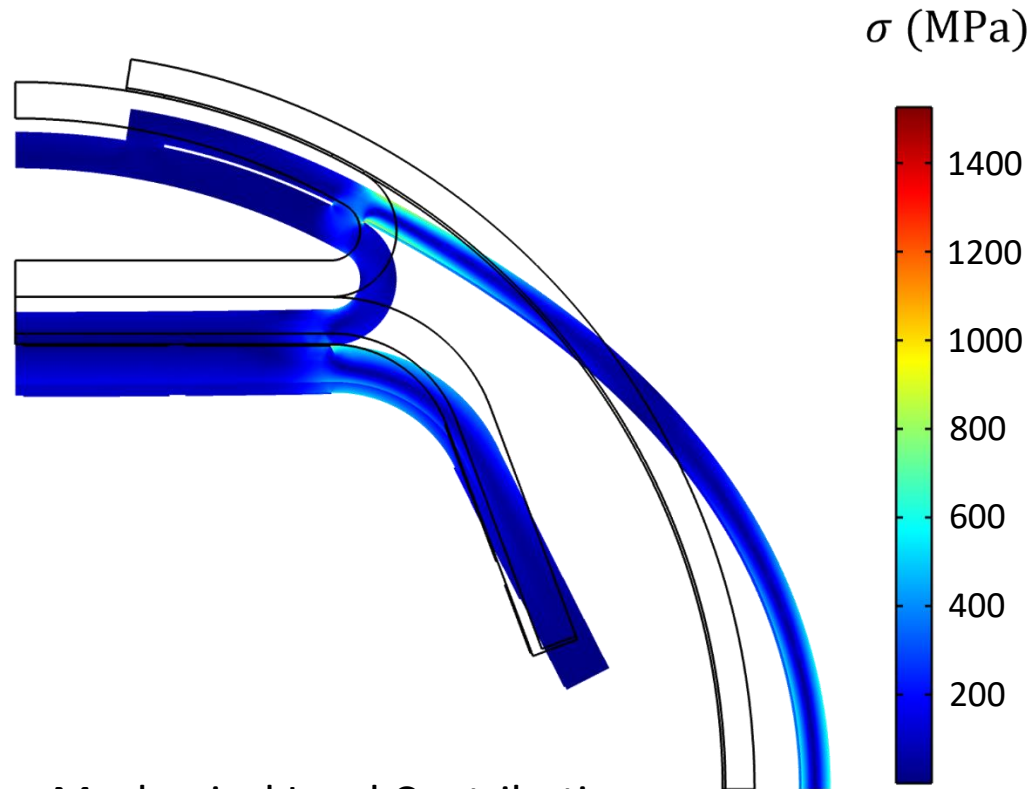

Mechanical Load Contributions:

- HTS: 8%
- Copper: 91%

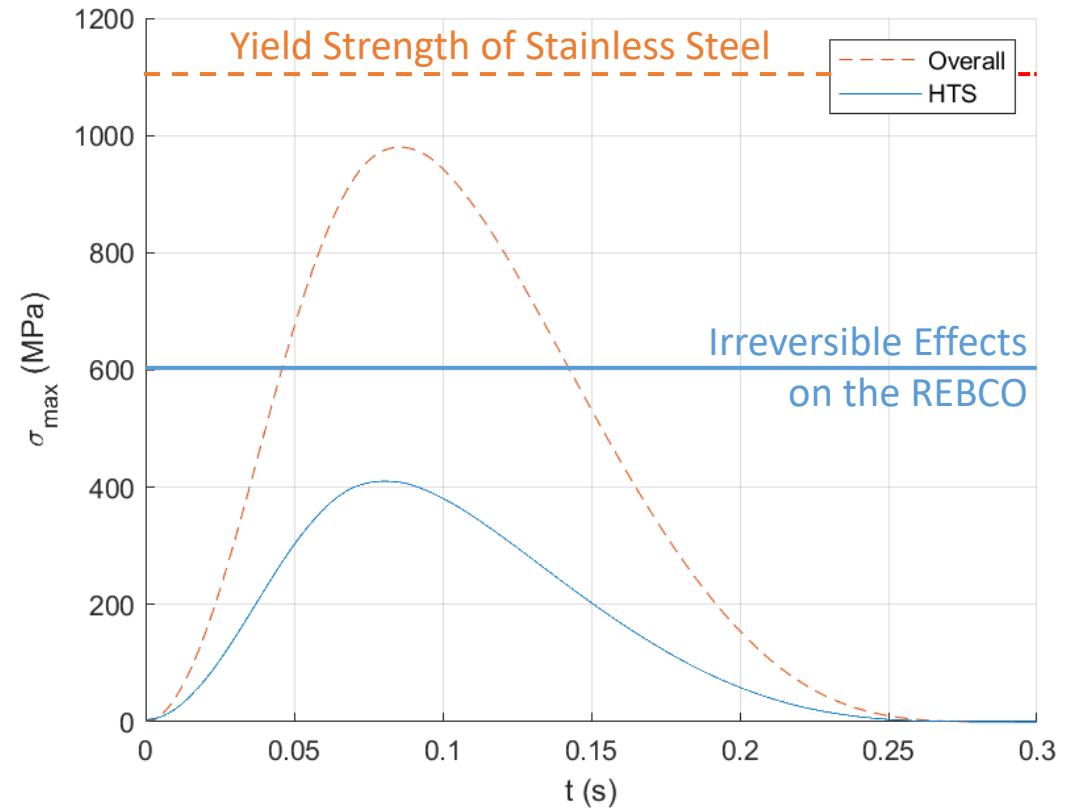

Deformed beam screen does not reach the cold bore

The coating can withstand the pulling pressures during a dipole quench

Pull-off Adhesion Tests:

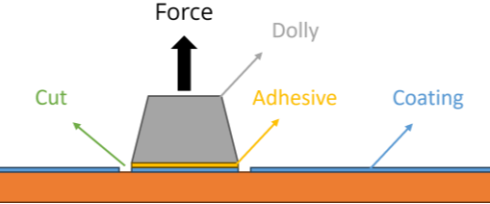

Calculated pulling forces in a quench:

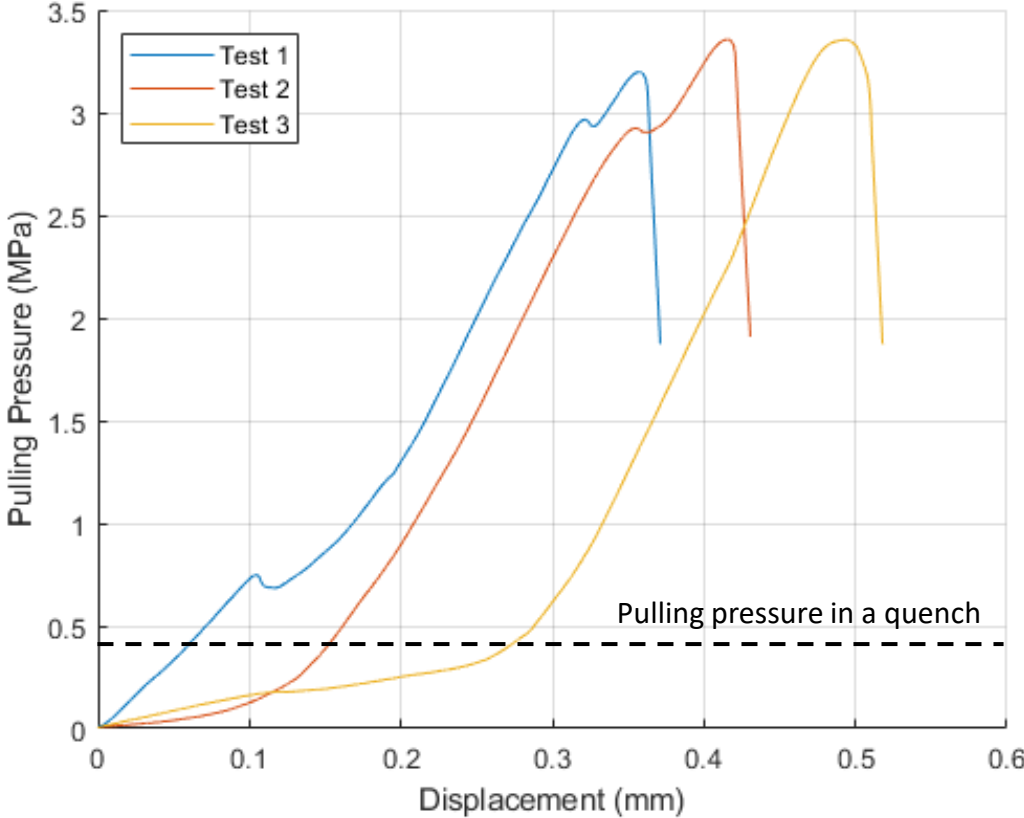
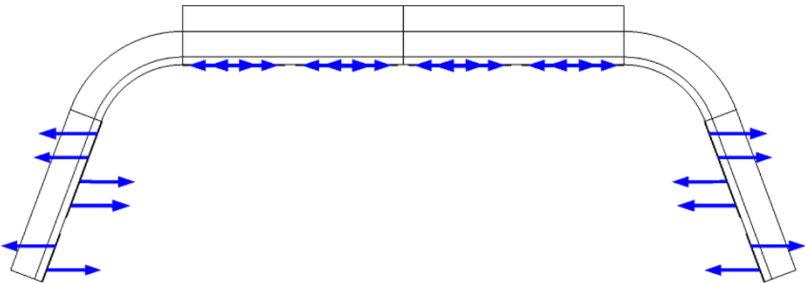

Outline

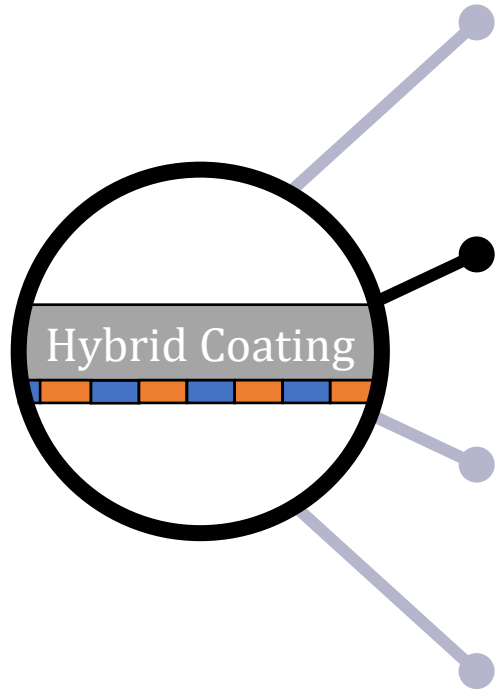

REBCO surface impedance under high magnetic fields

Simulations of the magnetic field homogeneity in the hybrid coated BS

Simulations of the thermomechanical robustness of the hybrid coated BS

Other considerations

Amorphous carbon is compatible with REBCO and lowers the SEY ~ 1

Secondary electron yield must be low to avoid formation of electron clouds

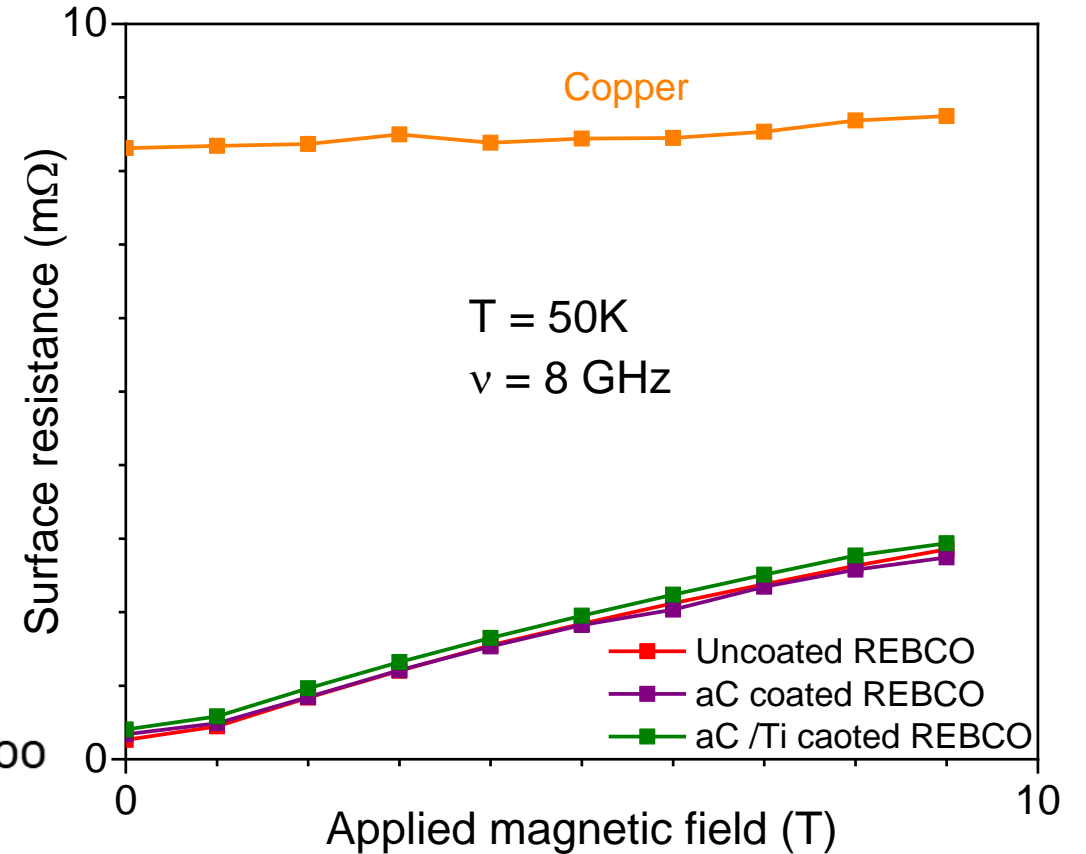
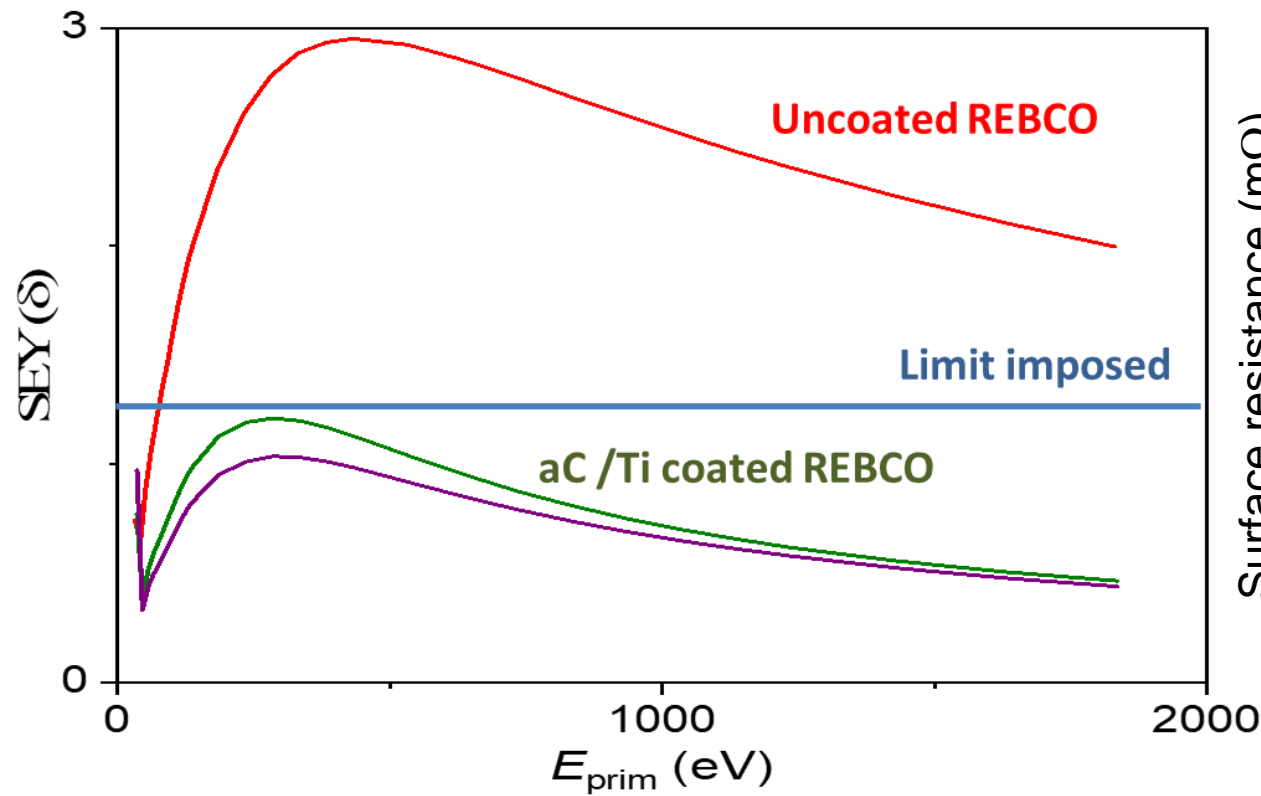

$Q_0 (R_s)$ remain stable at all temperatures and SR energies

Deposited power density in the FCC-hh BS

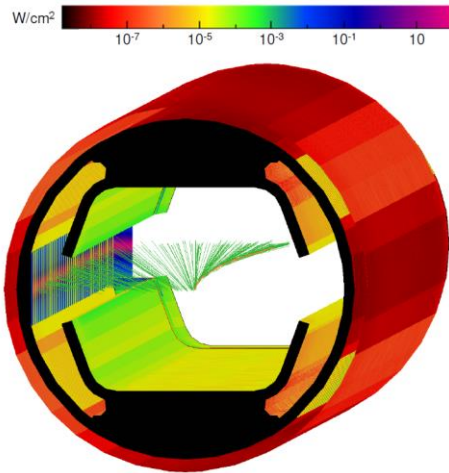

I. Bellafont, Ph.D. Thesis, UPC (2020)

ALBA spectral power density analysis

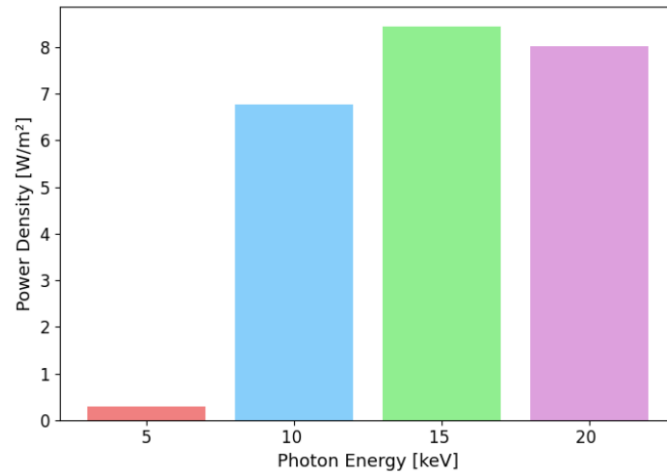

before SR 5 keV 10 keV 15 keV 20 keV after SR

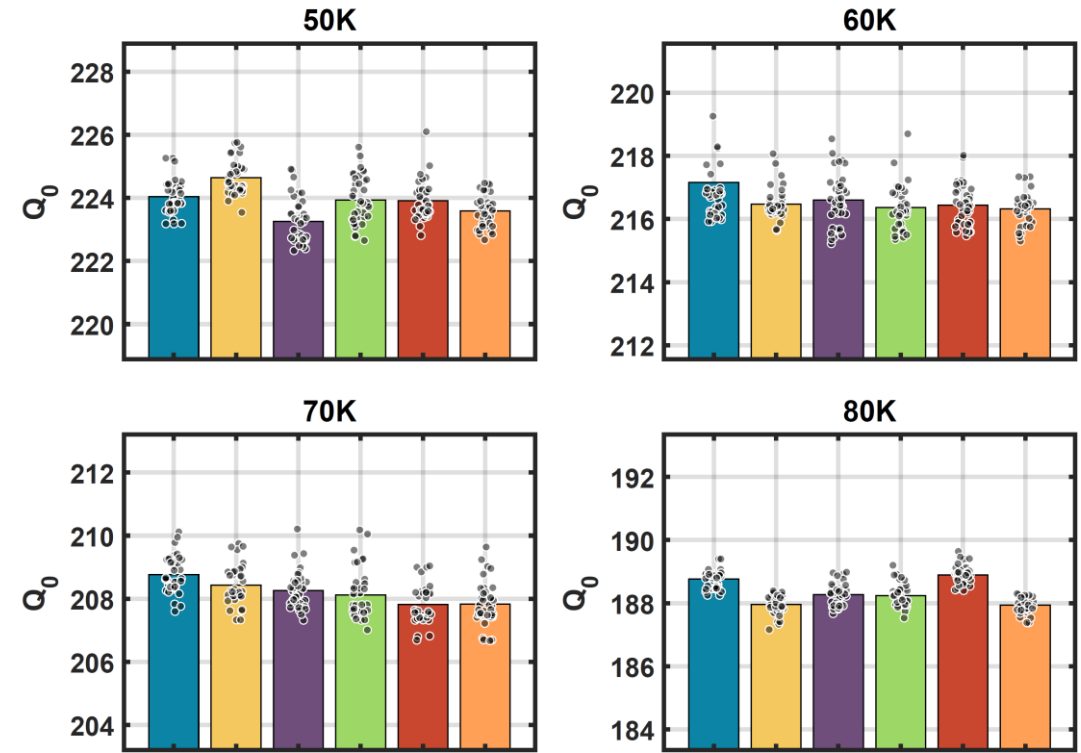

Q_0 measured during SR irradiation

P. Krkotic et al. In preparation

Initial PSD analysis suggests that the hybrid BS is vacuum compatible

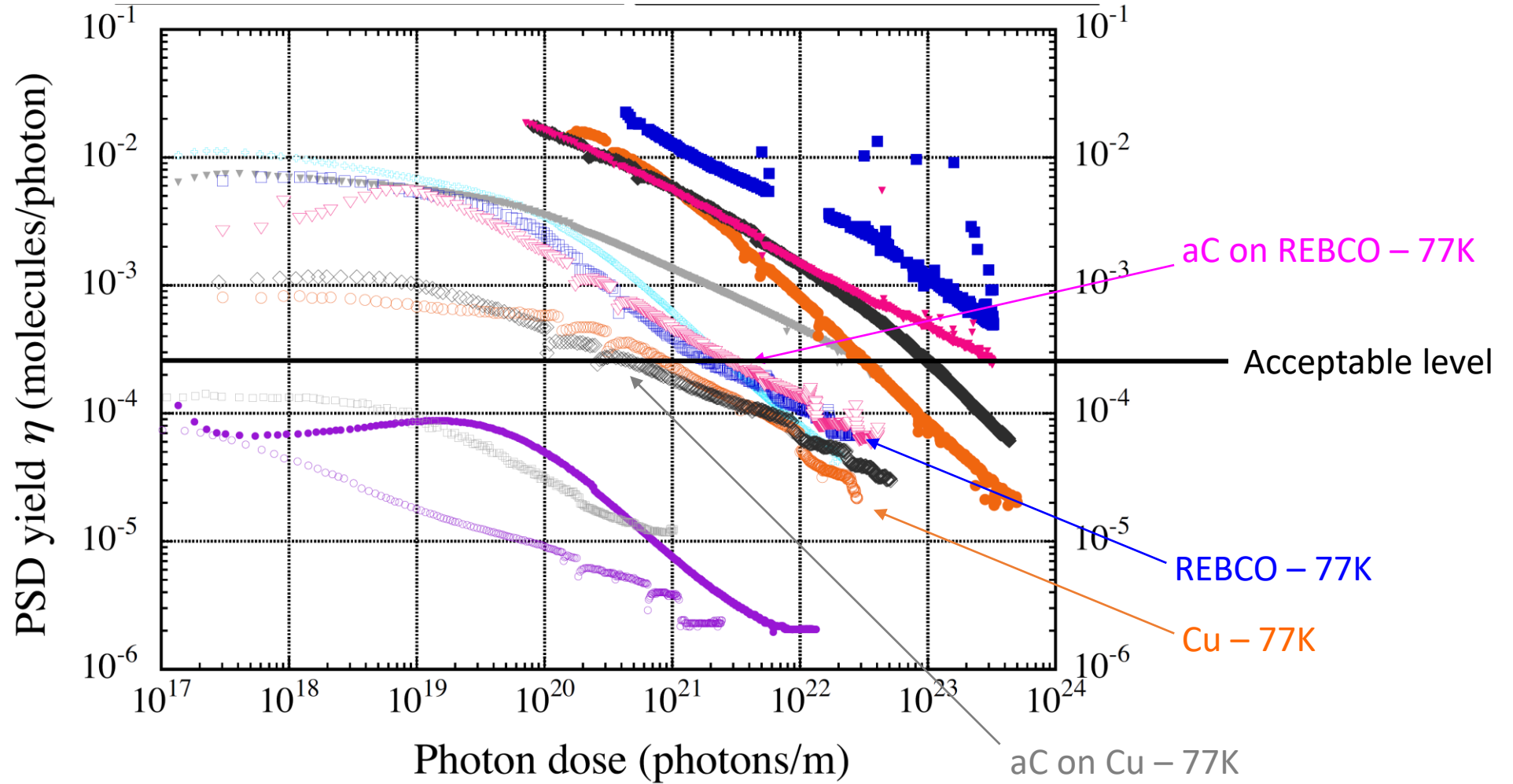

Due to the high SR flux and power,
PSD is expected to be highest gas load in the vacuum chamber

The hybrid BS resistive wall beam impedance outperforms that of Cu BS

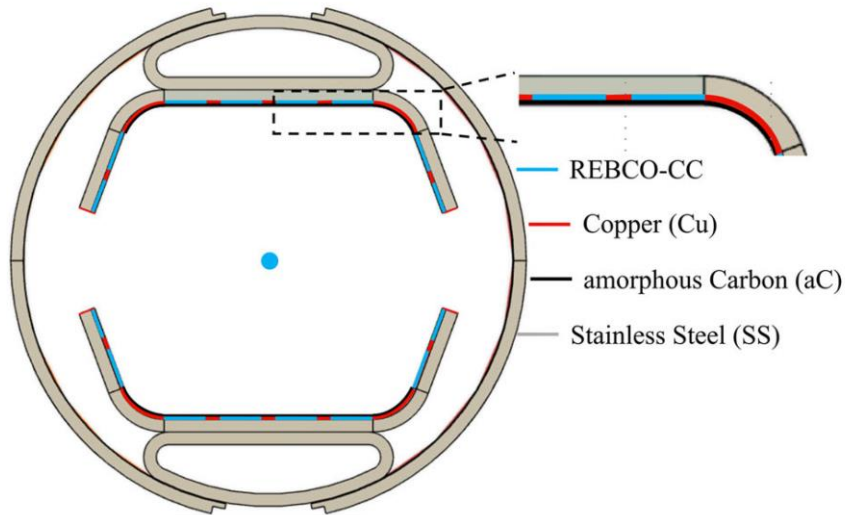

N. Tagdulang et al. *Eur. Phys. J. Plus* **139** (2024)

Calculated resistive wall impedance

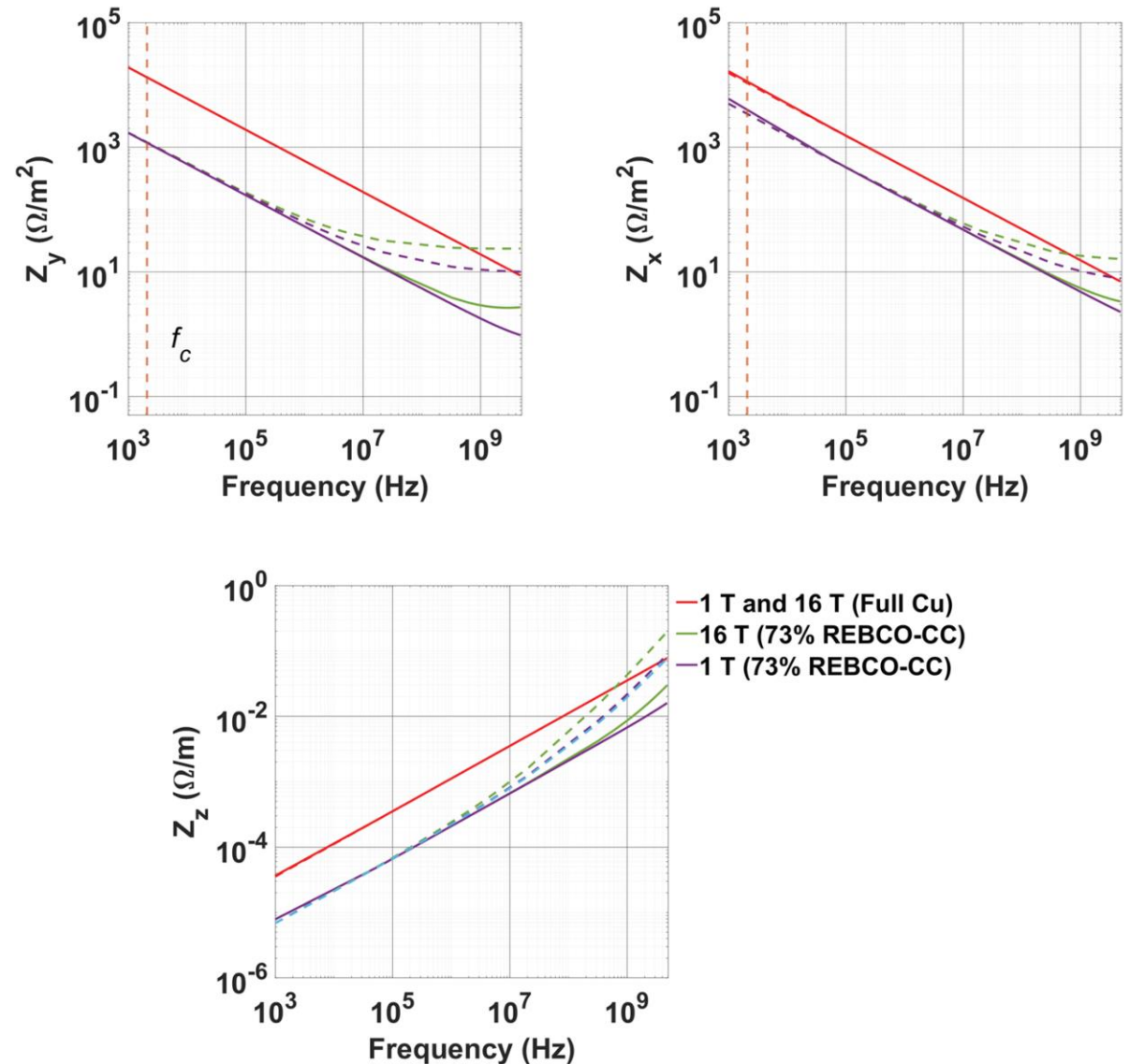

Conclusions

Hybrid REBCO – Cu coatings provide a solution to reduce the surface impedance of the FCC-hh beam-screen chamber working at 40K – 60K and 16T, hence it allows to operate the system with the consequent decrease in running cost.

Outlook

Current transfer between the REBCO and the Cu layers has to be studied in detail

Initial R_s characterization of REBCO at high cryogenic temperatures 60K – 80K shows that it could outperform Cu at higher temperatures than 50K up to fields of 14T. This opens the door to an even cheaper to run FCC-hh.

Combined function magnets technology could ease the quadrupole segmentation “issue”.

An (controlled) inhomogeneous thickness REBCO coating could further improve the magnetic field homogeneity by compensating the magnets own harmonics

REBCO Coated Conductors are commercially available

*with different widths in **Km length***

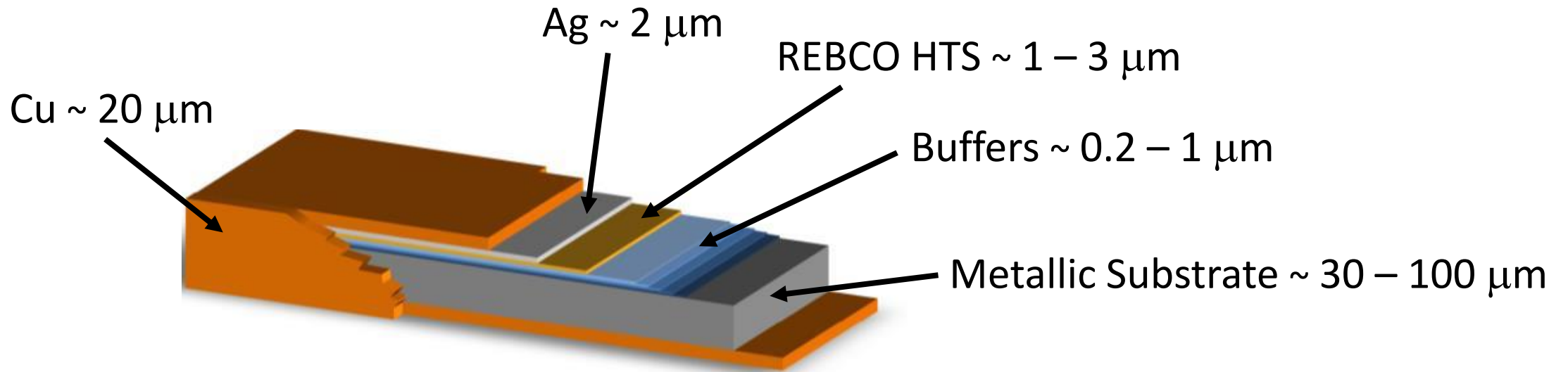

Coated Conductor

SUNAM

BRUKER
Bruker HTS GmbH

SuperOx

Fujikura

THEVA

SuperPower Inc.
A Furukawa Company

$$T_c \approx 91 \text{ K}$$

$$H_{c2} (4.2\text{K}) > 100 \text{ T}$$

$$H_{irr} (4.2\text{K}) > 60 \text{ T}$$

REBCO CCs' $R_s(H)$ shows a stronger ν dependence than Cu

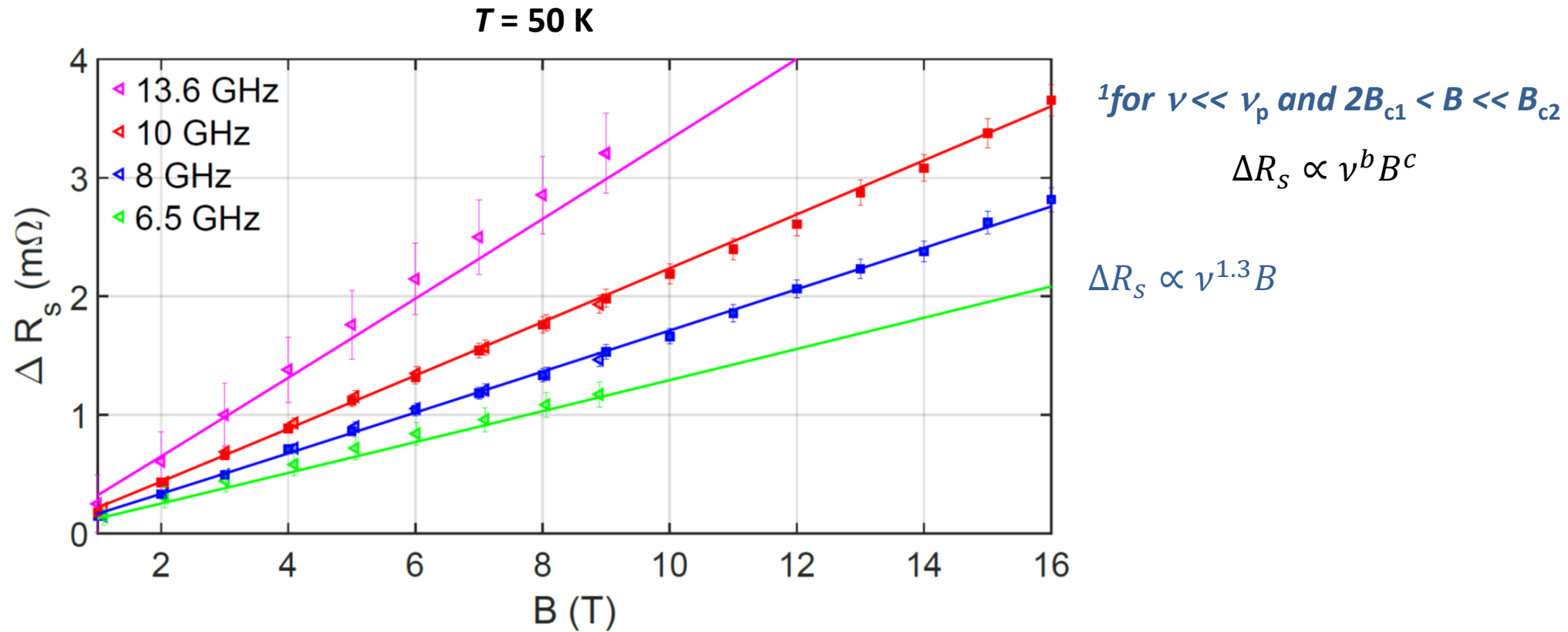

Measured $R_s(\nu^{1.3})$ dependence is weaker than the standard $R_s \propto \nu^2$ in HTS and in agreement with previous low-field measurements on thin films²