



## FCCee injector: linacs design for single- and multi-bunch effects

S. Bettoni<sup>1</sup>, A. Latina<sup>2</sup>, A. Grudiev<sup>2</sup>, P. Craievich<sup>1</sup>, S. Doebert<sup>2</sup>, A. Kurtulus<sup>2</sup>, J.-Y. Raguin<sup>1</sup>, R. Zennaro<sup>1</sup>

<sup>1</sup> Paul Scherrer Institut, Villigen (Switzerland)

<sup>2</sup> CERN, Meyrin (Switzerland)

# Outlook

## ■ Evolution of the FCCee injector complex design

### ■ Static effects:

- Transverse dynamics: emittance preservation in presence of elements misalignments and mitigation strategies
- Longitudinal phase space manipulation: match to the target energy spread and bunch length

### ■ Dynamic effects:

- Single-bunch jitter amplification
- Multi-bunch jitter amplification
- Interpretation of the obtained results

## ■ Conclusions

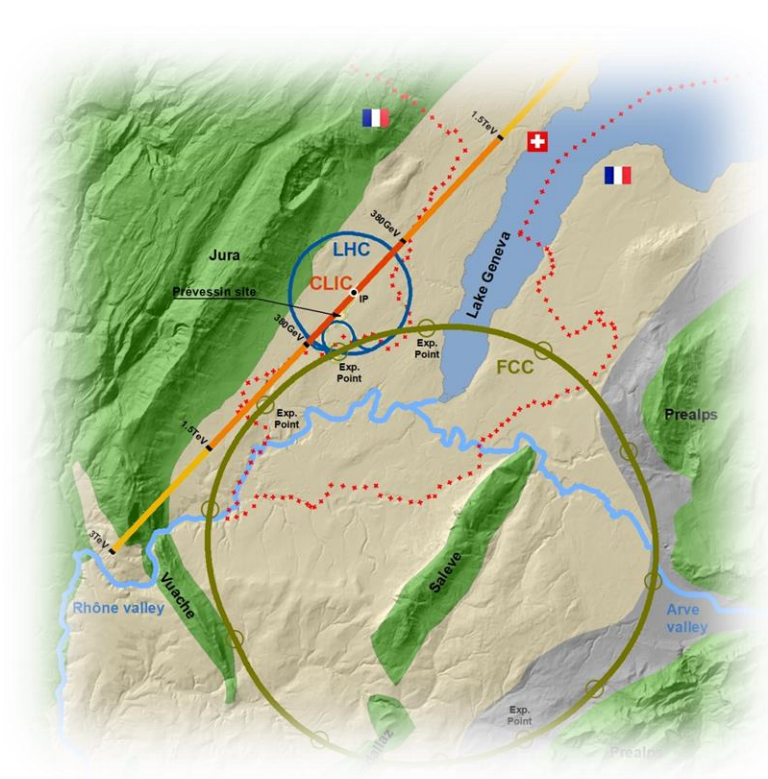

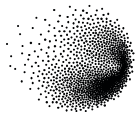

### Option 1 (with SPS/PBR)

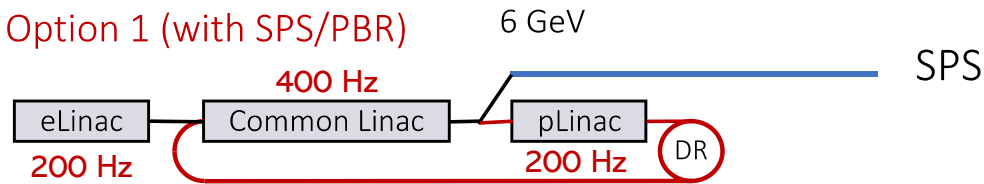

Use the SPS as pre-booster to bring the beam energy from 6 GeV up to 20 GeV (linac up to 6 GeV)

### Option 2 (HE Linac)

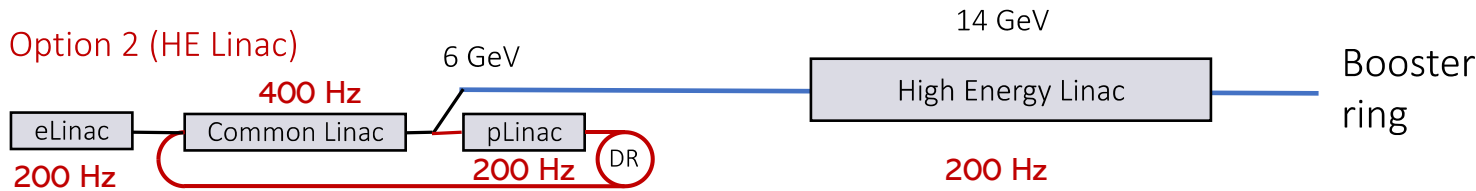

Inject directly the 20 GeV beam to the booster ring (linac up to 20 GeV)

Layout A

### Option 3 (present)

Layout B

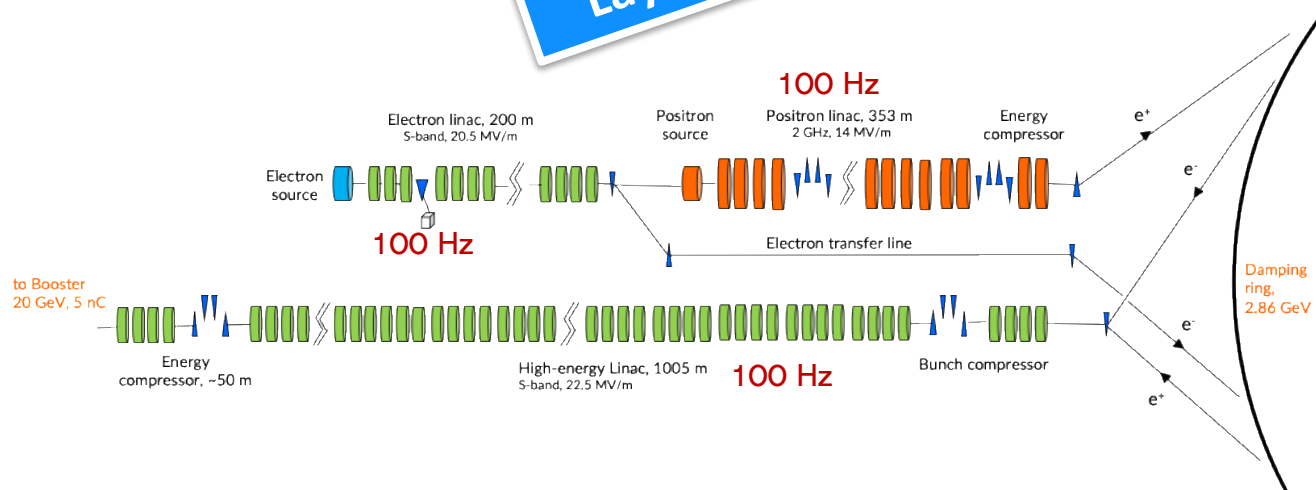

- No common linac with 2x repetition rate, no long return line and large arc
- Positrons generated at a lower electron beam energy (possible because of the large yield)
- Higher energy DR (2.86 GeV) for positrons and DR for electron beam
- Possibility to generate flat beams from DR
- Better stability and improved transverse quality electron bunches at the injection to the HE linac

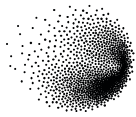

# PSI Target parameters

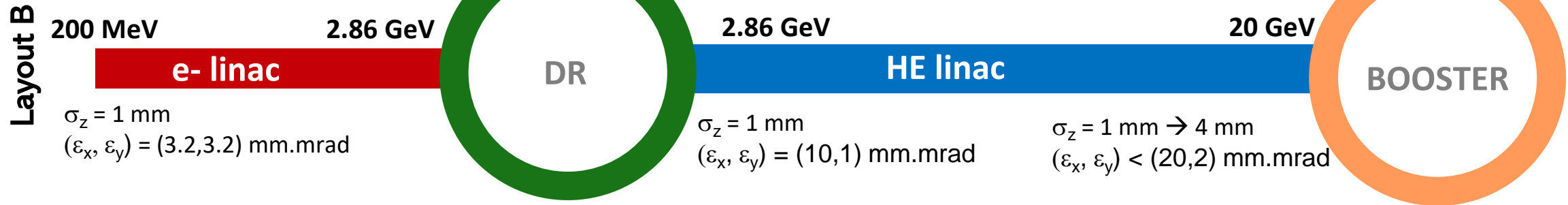
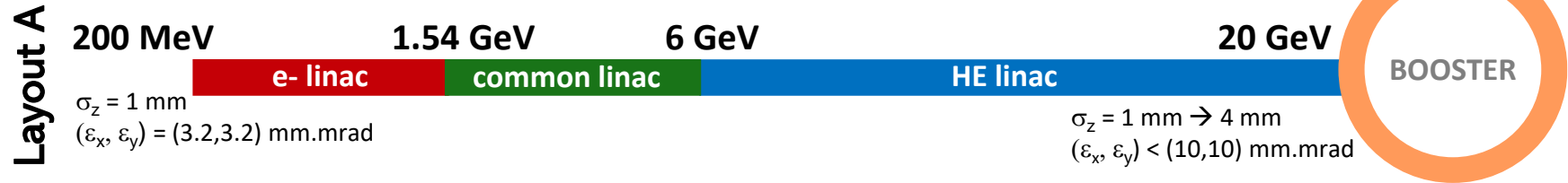

| Parameter                    | Value     | Unit    |
|------------------------------|-----------|---------|
| Norm. emittance (x, y) (rms) | <(20,2)   | mm.mrad |
| Bunch length (rms)           | 4         | mm      |
| Energy spread (rms)          | 0.10-0.15 | %       |
| Transverse jitter            | 1         | sigma   |
| Number of bunches            | 4         |         |
| Bunch spacing                | 25        | ns      |
| Charge variation             | "0"-5     | nC      |

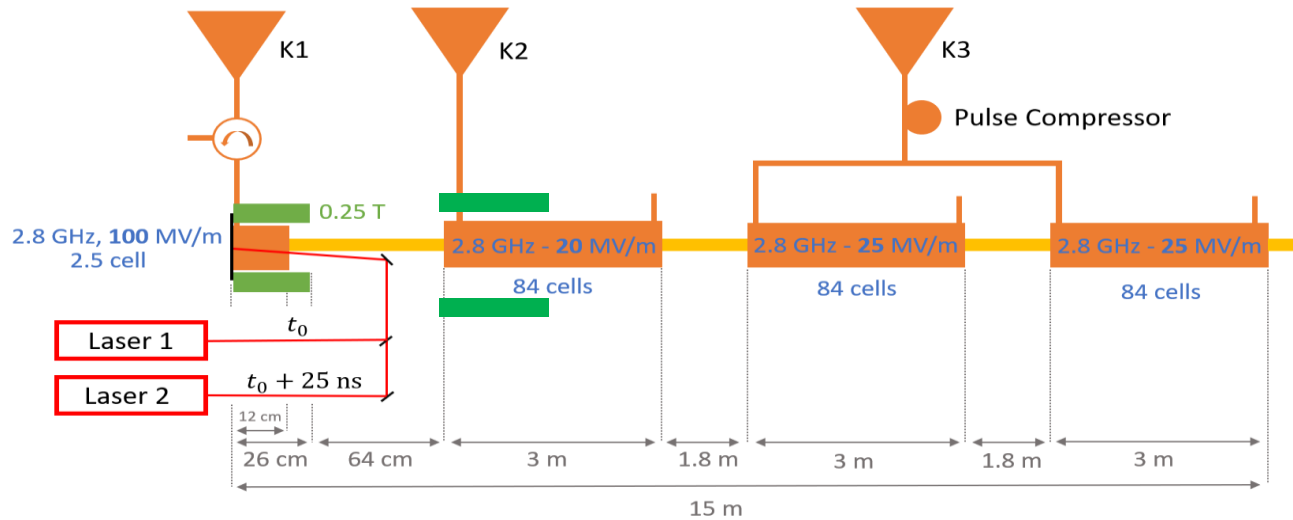
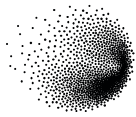

- Generation of **4 x 200 MeV** electron bunches varying the charge from “**0**” to **several** nC
- **Top-up** mode studied: solution to preserve the shot-by-shot emittance for different bunch charges (Digital Micromirror Device)
- Design published in <https://doi.org/10.1016/j.nima.2024.169261>
- **Next steps:** prototyping of hardware and testing of top up mode charge variation

| Bunch parameter      | Simulation                                      | Target      |
|----------------------|---|-------------|
| Transverse emittance | 3.14 mm.mrad (rms)<br>Assumed 3.2 mm.mrad (rms) | < 4 mm.mrad |
| Bunch length         | 0.96 mm (rms)                                   | 1 mm        |
| Final energy         | 190 MeV   | 200 MeV     |
| Energy spread        | 0.2% (390 keV )                                 | < 0.5 %     |
| Bunch charge         | 5 nC  | 5 nC        |

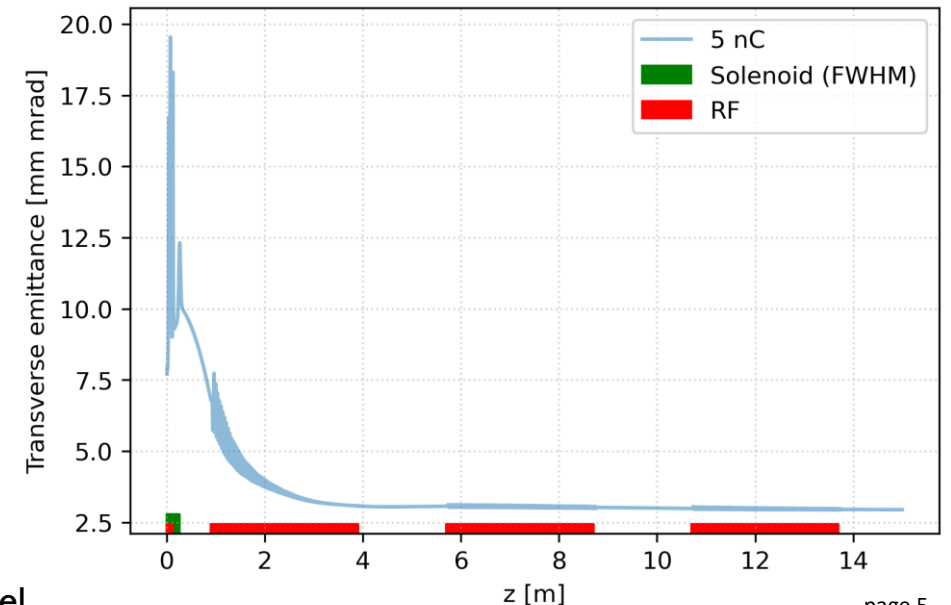

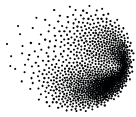

## Lattice modeling:

- FODO lattice with **90 degs** phase advance/cell
- One quadrupole/RF structure: distance among the quadrupoles = **3.75 m**
- RF structures' wakefield: Bane model (a in the following is the iris radius)
- 90 degrees of the RF cavity corresponds to on-crest operation
- $a/\lambda$  corresponds to the mean  $a/\lambda$  (a is the average structure radius)



Important for the bunch jitter amplification

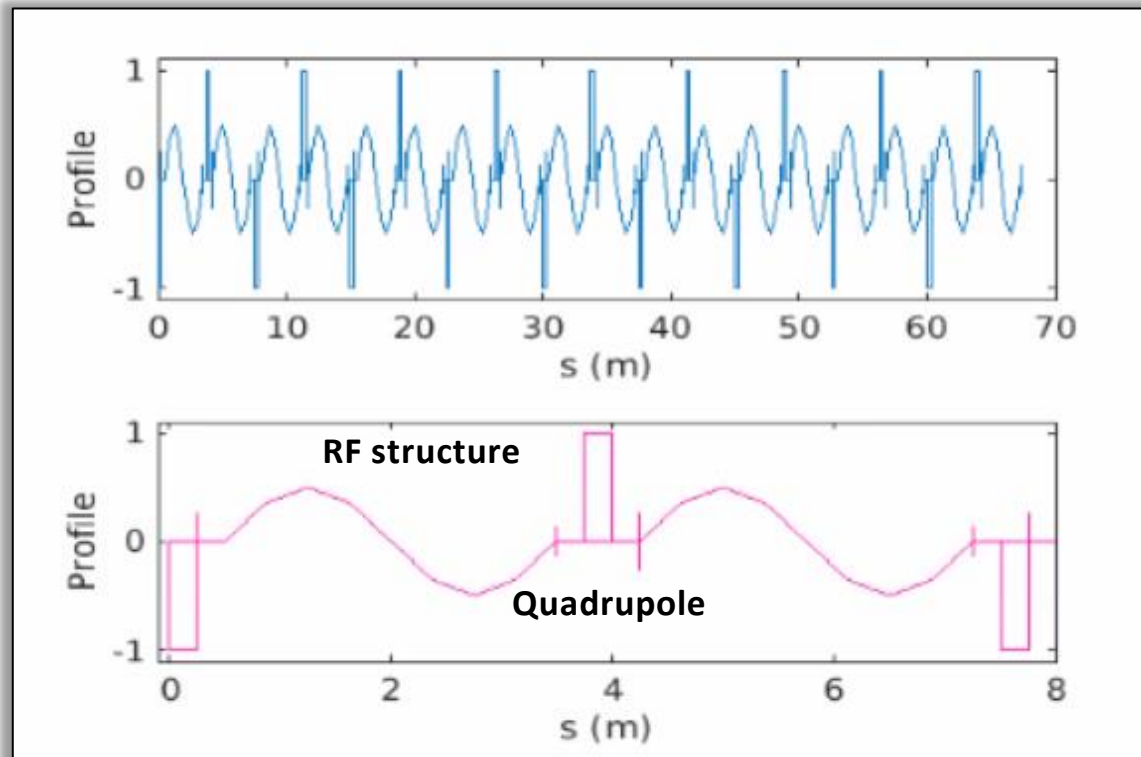

## Simulation codes:

- MAD-X: optics matching
- Elegant: single bunch tracking simulations longitudinal plane
- **RF-Track - see talk by A. Latina at this FCC week:** single and multi-bunch tracking simulations transverse plane

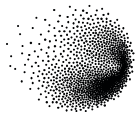

# SINGLE BUNCH

## Static misalignments

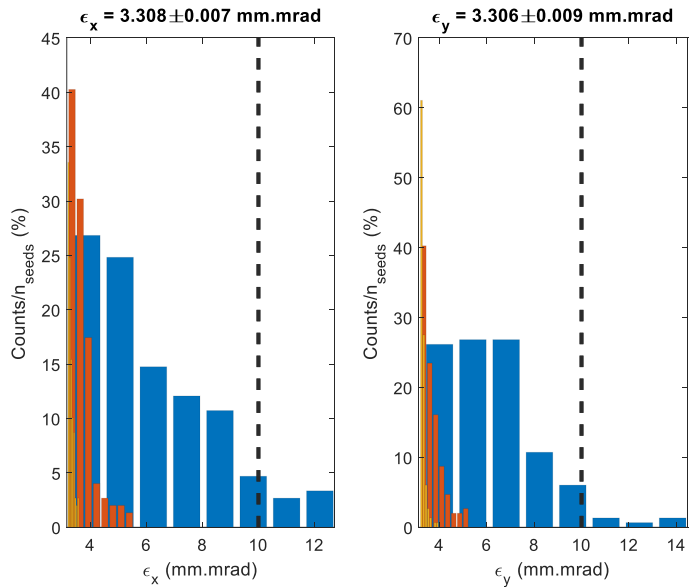

**Source:** misalignments of the lattice elements  
**Effect:** emittance growth  
**Cures:** trajectory correction schemes and RF aperture

## Bunch jitter amplification

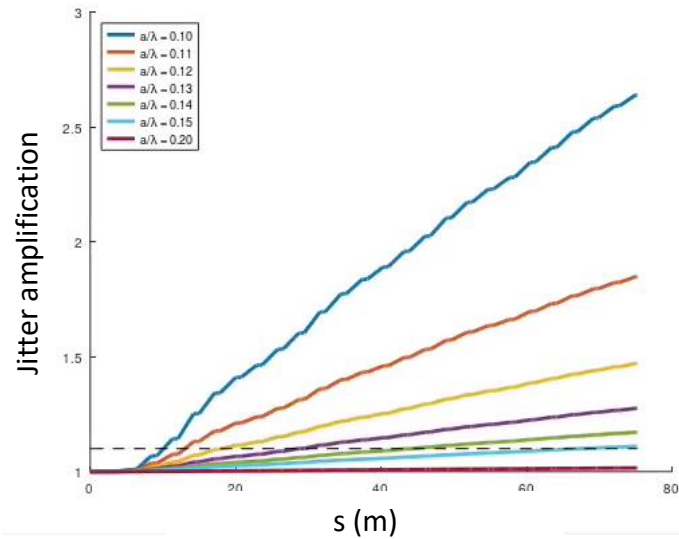

**Source:** off-axis/off-angle incoming beam and short-range wakefield  
**Effect:** position/angle jitter amplification  
**Cures:** lattice and RF aperture

# MULTI-BUNCH

## Bunch-to-bunch jitter amplification

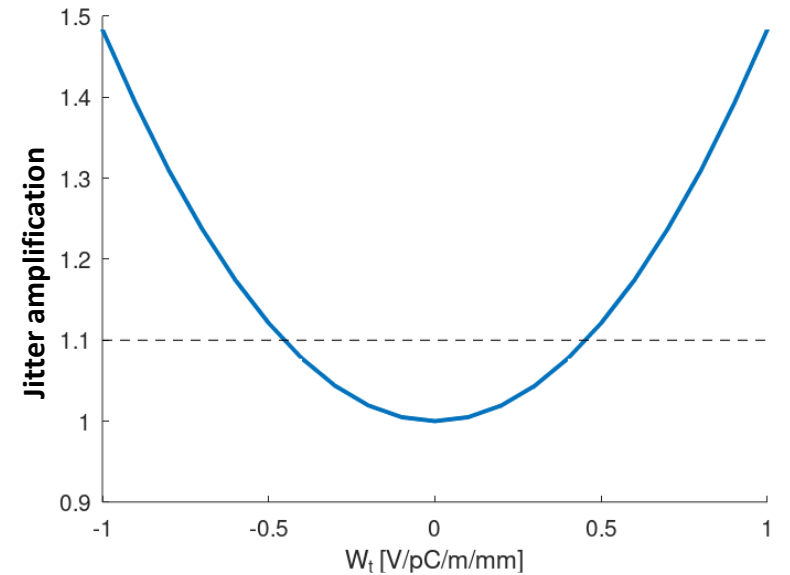

**Source:** preceding bunch and long-range wakefield  
**Effect:** bunch-to-bunch jitter amplification  
**Cures:** lattice and RF high order mode mitigation



Transverse Dynamics: single bunch: static

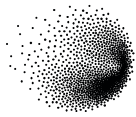

## Elements misalignments

**Quadrupoles**  
 Offset x, y = 50 μm rms  
 Gaussian distribution

**RF cavities**  
 Offset x, y = 100 μm rms  
 Gaussian distribution

**BPM**  
 Offset x, y = 30 μm rms  
 Resolution x, y = 10 μm  
 Gaussian distributions

Very **“generous”** misalignments assumed and more than **98%** of the “good seeds” considered (also 90% in other designs)

## Steering algorithms

### One-to-one orbit correction

1. Orbit  $x_i$  with errors computed
2. Response matrix computed
3. Correctors strengths calculated (SVD) to steer the beam

### Dispersion Free Steering (DFS)

1. Orbit  $x_i$  with errors computed
2. Response matrix computed
3. Off-energy beam (different RF phase) orbit  $x_{\Delta E,i}$  computed
4. Response matrix computed
5. Correctors strengths calculated, minimizing  $\chi^2$  defined as:

$$\chi^2 = \sum_{\text{bpms}} x_i^2 + \omega^2 \sum_{\text{bpms}} (x_{\Delta E,i} - x_i)^2 + \beta^2 \sum_{\text{corr}} \theta_j^2$$

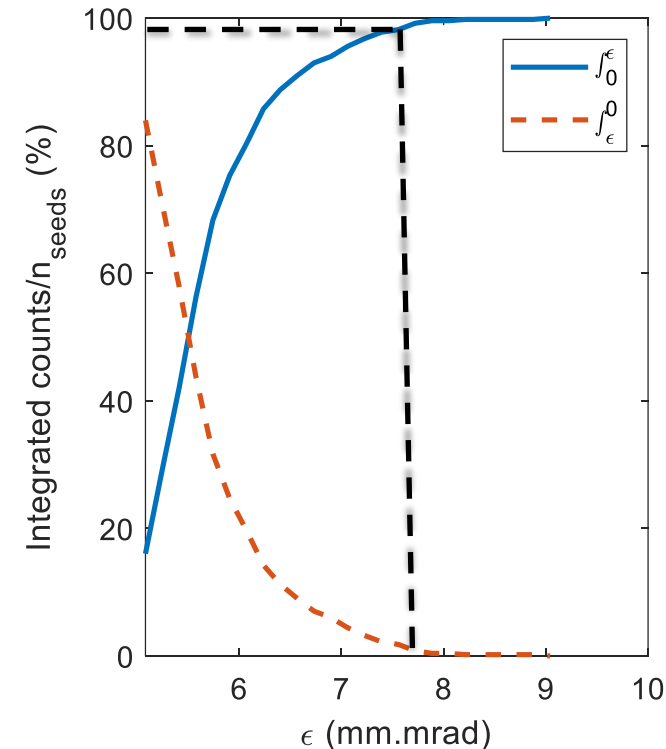
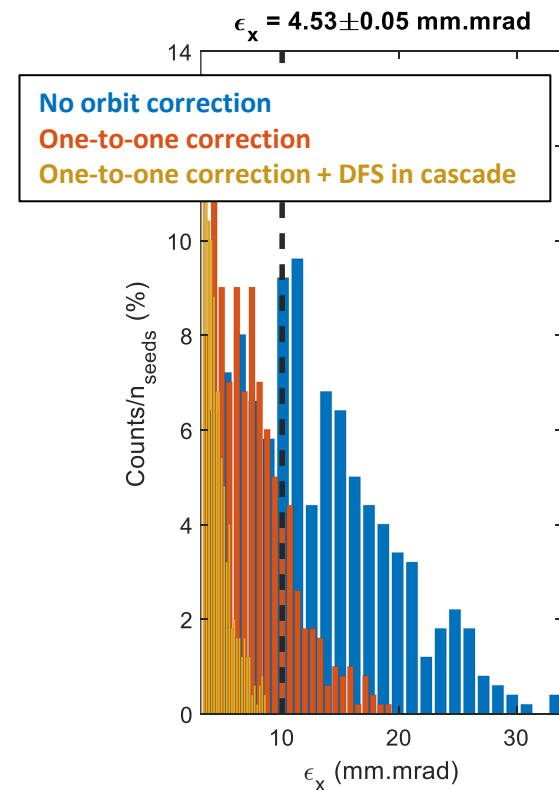

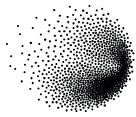

PSI

# Static single bunch layout A: results

Layout A

LOW ENERGY  
(0.2-1.56-6 GEV)

| $a/\lambda$ | a (mm)      | e- Linac   | Common Linac (82 deg) | Common Linac (90 deg) |
|-------------|-------------|------------|-----------------------|-----------------------|
| 0.10        | 10.7        | 5.0        | /                     | 5.1                   |
| 0.12        | 12.9        | 0.8        | 1.6                   | 0.6                   |
| 0.13        | 13.9        | /          | /                     | /                     |
| 0.14        | 15.0        | 0.3        | 0.8                   | 0.2                   |
| <b>0.15</b> | <b>16.1</b> | <b>0.2</b> | <b>0.5</b>            | <b>0.1</b>            |

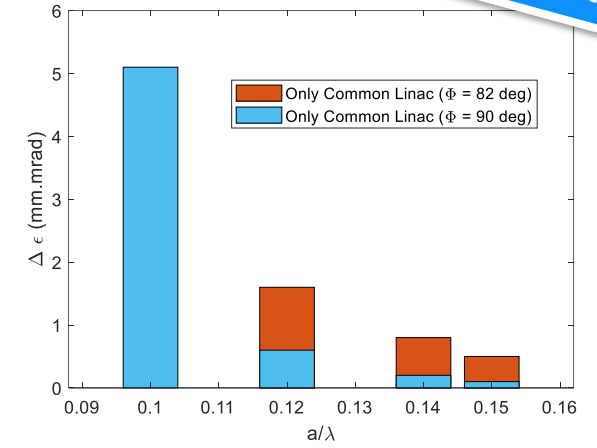
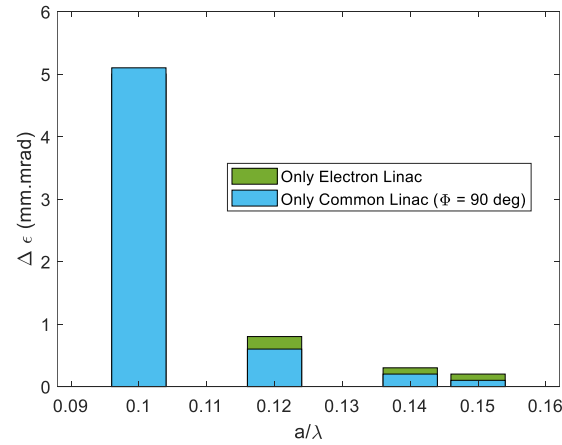

### Outcomes:

- Largest emittance growth/length at the low energy section → important reduction in case of the **e-damping ring** option (forgetting what upstream of DR)
- Emittance growth strongly depends on the **RF operating phase**

HE LINAC  
(6-20 GEV)

| $a/\lambda$ | a (mm)      | e- linac   | Common linac (90 deg) | HE linac, Nbins = 10 |
|-------------|-------------|------------|-----------------------|----------------------|
| 0.10        | 10.7        | 5.0        | 5.1                   | 0.3                  |
| 0.11        | 11.8        | 2.4        | 1.7                   | 0.3                  |
| <b>0.12</b> | <b>12.9</b> | <b>0.8</b> | <b>0.6</b>            | <b>0.3</b>           |
| 0.13        | 13.9        | 0.7        | 0.3                   | 0.2                  |
| 0.14        | 15.0        | 0.3        | 0.2                   | 0.1                  |
| 0.15        | 16.1        | 0.2        | 0.1                   | 0.1                  |

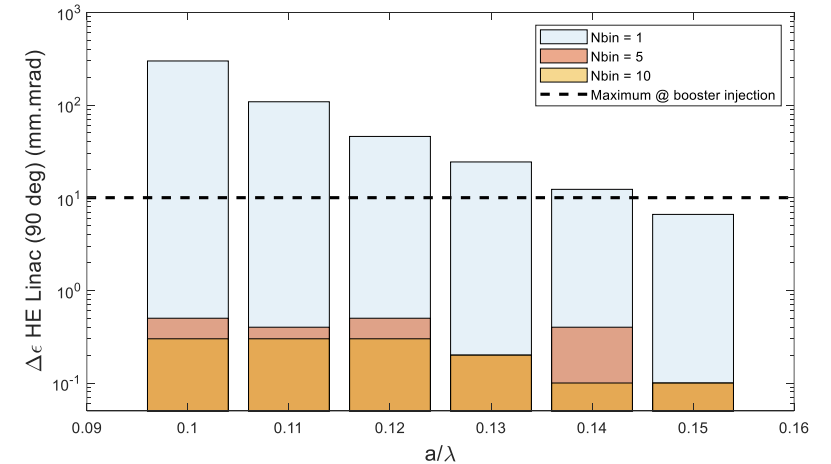

### Outcomes:

- Relatively **small emittance growth** even for smaller RF apertures
- Essential to separate the orbit steering/DFS in **several sections** (what we call bins/sub-sections)

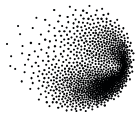

**e- linac (0.2-2.86 GeV)**

$a/\lambda = 0.15$

| Sub-sections | $\Delta\varepsilon$ (mm.mrad) | $\varepsilon$ (mm.mrad) |
|--------------|-------------------------------|-------------------------|
| 3            | 0.5                           | 3.7                     |
| 4            | 0.4                           | 3.6                     |
| <b>5</b>     | <b>0.3</b>                    | <b>3.5</b>              |
| 7            | 0.3                           | 3.5                     |
| 10           | 0.3                           | 3.5                     |

$a/\lambda = 0.12$

| Sub-sections | $\Delta\varepsilon$ (mm.mrad) | $\varepsilon$ (mm.mrad) |
|--------------|-------------------------------|-------------------------|
| 3            | 1.8                           | 5.0                     |
| 4            | 1.5                           | 4.7                     |
| <b>5</b>     | <b>1.2</b>                    | <b>4.4</b>              |
| 7            | 1.2                           | 4.4                     |
| 10           | 1.2                           | 4.4                     |

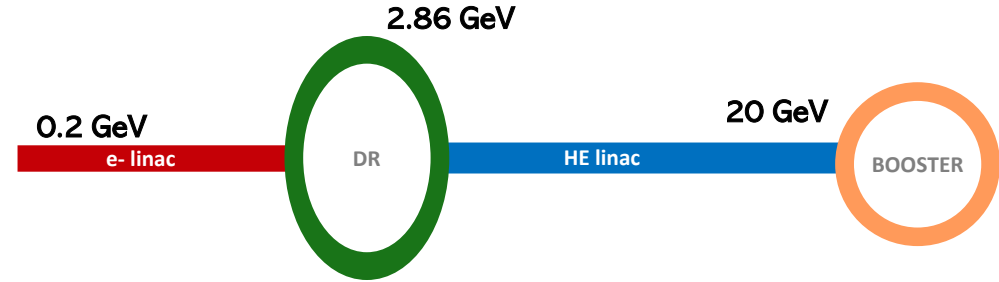

**HE linac (2.86-20 GeV)**

$a/\lambda = 0.12$

| Sub-sections | $\Delta\varepsilon$ (mm.mrad) | $\varepsilon$ (mm.mrad) |
|--------------|-------------------------------|-------------------------|
| <b>8</b>     | <b>0.6</b>                    | <b>1.6</b>              |
| 9            | 0.6                           | 1.6                     |
| 10           | 0.6                           | 1.6                     |
| 12           | 0.6                           | 1.6                     |

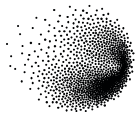

- Assumed very “generous” rms Gaussian distributed misalignments: 50  $\mu\text{m}$  for quadrupoles, 100  $\mu\text{m}$  per RF structures, and 30  $\mu\text{m}$  per BPM
- Applied one-to-one correction (main correction) and dispersion free steering (BPM resolution = 10  $\mu\text{m}$ ) in cascade
- More than the 98% of the good seeds considered in the calculation of the emittance growth

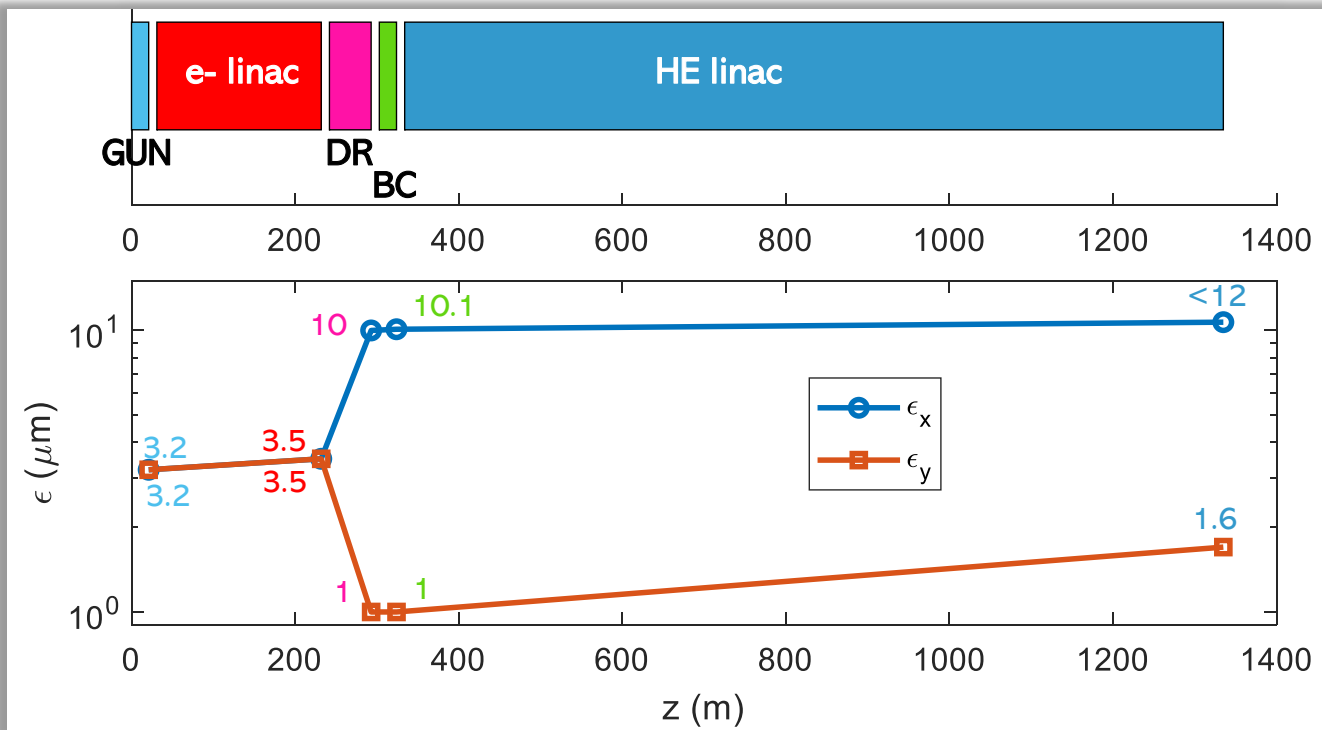

| $\epsilon_x$ (mm.mrad) |        | $\epsilon_y$ (mm.mrad) |        |
|------------------------|--------|------------------------|--------|
| Target                 | Design | Target                 | Design |
| <20                    | <12    | <2                     | 1.7    |

- e- linac ( $a/\lambda = 0.15$ ):**
  - Emittance good enough for the positron production
  - Emittance expected to be good enough for the injection to DR (tbc by the DR group)
- HE linac ( $a/\lambda = 0.12$ ):**
  - Emittance growth fulfilling the booster requirements with about 40% margin in both planes



Longitudinal Dynamics: single bunch: static effects

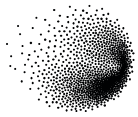

**Goals:** projected energy spread ~~~0.1-0.15%~~ and bunch length up to 4 mm at the booster injection

**Procedure:** scan of the RF frequency, gradient, and geometry ( $a/\lambda$ -being  $a$  the iris radius).

For each configuration, the maximum bunch length and the corresponding phase giving the target energy spread are selected

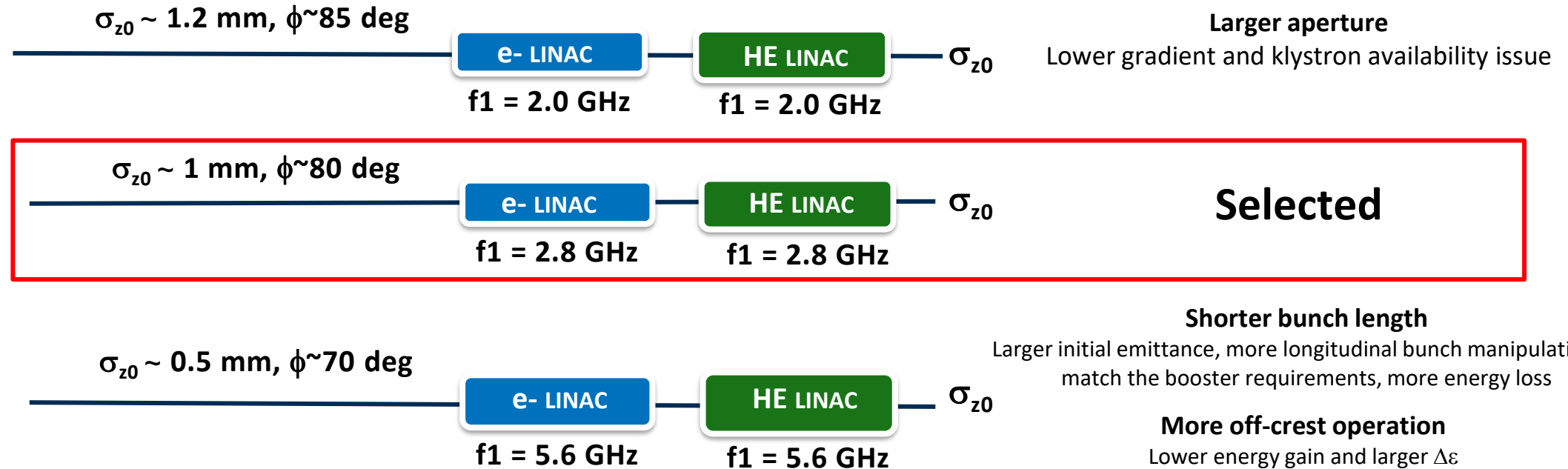

- All these configurations produce energy spread  $\sim 0.1-0.15\%$ , BUT the linacs must operate the linac *off-crest* (worse for the emittance and energy efficiency), and *manipulate* more the beam to match the booster requirement on the bunch length in case of the higher frequency
- Preferred solution: operate *on-crest*, and match the final parameters in the high energy section using the **energy compressor**

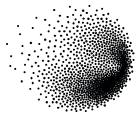

# The energy compressor (EC): single-bunch scenario

**Goal:** manipulate the bunch longitudinal phase space

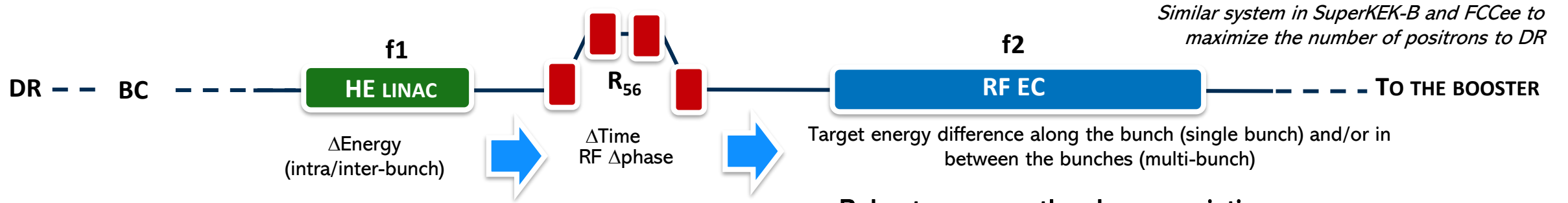

Included the 0.7% residual chirp coming from BC downstream of DR

|                           | V = 450 MV | V = 500 MV | V = 600 MV |
|---------------------------|------------|------------|------------|
| Initial bunch DE/E (%)    |            | 0.6        |            |
| Initial bunch length (mm) |            | 0.8*       |            |
| Final bunch DE/E (%)      | 0.09       | 0.04       | 0.11       |
| Final bunch length (mm)   | 4.05       | 4.05       | 4.05       |

\*Slightly modification of the bunch length compatible with the other aspects

## Robustness over the charge variation

|  | Q = 5 nC | Q = 5 pC |
|--|----------|----------|
| Initial bunch ΔE/E (%)                   | 0.6      | 0.14     |
| Initial bunch length (mm)                | 0.8      | 0.8      |
| Final bunch ΔE/E (%)                     | 0.11     | 0.13     |
| Final bunch length (mm)                  | 4.06     | 1.04     |
| Final Δt from B <sub>1</sub> @ 5 nC (ps) | 0        | -29.0    |

### Outcomes:

- The bunch length and the energy spread can be **independently** adjusted (also smaller energy spread achievable)
- Minimized the **emittance growth** and maximized the **energy efficiency** operating HE linac on-crest
- **Tunability** of the beam to the booster without modifying the linac's settings

### Questions:

- Is the shorter bunch length for 5 pC tolerable? It seems the case (booster). Confirmed?
- Is the time delay 5 pC vs 5 nC bunch acceptable? It seems the case (booster/injection). Confirmed?
- Is the different bunch length 5 pC vs 5 nC acceptable? It seems the case (booster). Confirmed?

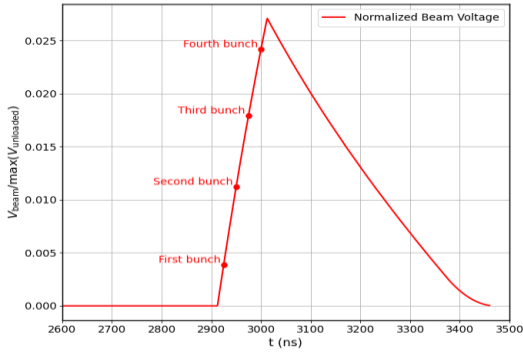

LLRF must adjust the RF profile pulse for each charge. Can the EC be used for the charge variation setups?

**Request:** Scan of the single-bunch charge "0"-5 nC

**Possible solution:** LLRF must be adjusted for each charge value

**Alternative solution:** is it possible to use EC to compensate for the multi-bunch effects?

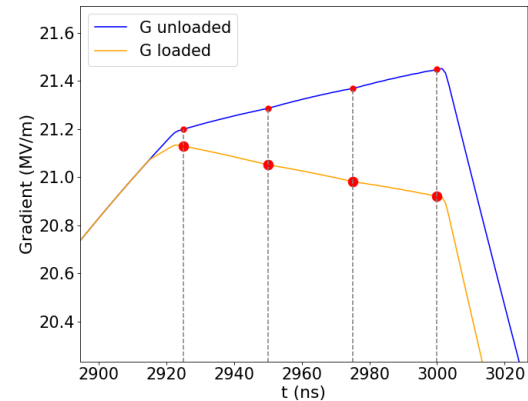

**HE**

Different energy of each bunch → energy offset

**HE**

Different gradient in the HE linac for each bunch → energy chirp

**EC**

Different gradient in the EC RF cavities → compensation  $\Delta E/E$

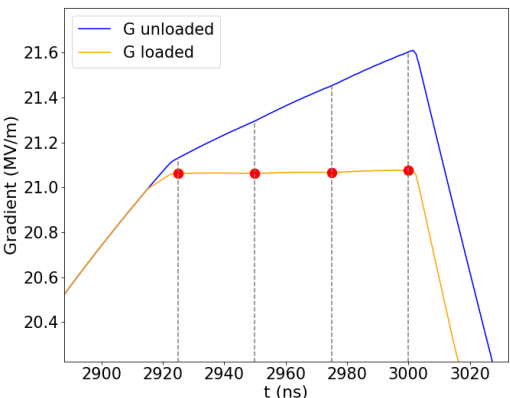

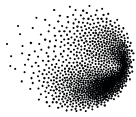

LLRF must adjust the RF profile pulse for each charge. Can the EC be used for the charge variation setups?

Q = 5 nC



$R_{56} = 0.55 \text{ m}$   
 $V = 620 \text{ MV}$   
(450 MV for single-bunch)



Q = 5 pC

Included the 0.7% residual chirp coming from BC downstream of DR

|  | B <sub>1</sub> | B <sub>2</sub> | B <sub>3</sub> | B <sub>4</sub> |
|--|----------------|----------------|----------------|----------------|
| Initial rms bunch length (ps)                                | 0.80           | 0.80           | 0.80           | 0.80           |
| Initial single bunch $\Delta E/E$ (%)                        | 0.61           | 0.61           | 0.61           | 0.61           |
| Initial offset centroid $\Delta E/E$ from B <sub>1</sub> (%) | 0              | -0.31          | -0.59          | -0.93          |
| Final rms bunch length (mm)                                  | 4.06           | 4.07           | 4.09           | 4.10           |
| Final single bunch $\Delta E/E$ (%)                          | 0.11           | 0.11           | 0.10           | 0.09           |
| Final offset centroid $\Delta E/E$ from B <sub>1</sub> (%)   | 0              | -0.01          | -0.03          | -0.05          |
| Final centroid $\Delta t$ from B <sub>1</sub> (ps)           | 0              | 5.7            | 11.0           | 17.3           |

Included the 0.7% residual chirp coming from BC downstream of DR

|   | B <sub>1</sub> | B <sub>2</sub> | B <sub>3</sub> | B <sub>4</sub> |
|---|----------------|----------------|----------------|----------------|
| Initial rms bunch length (ps)   | 0.80           | 0.80           | 0.80           | 0.80           |
| Initial single bunch $\Delta E/E$ (%)                                   | 0.14           | 0.14           | 0.14           | 0.14           |
| Initial offset centroid $\Delta E/E$ from B <sub>1</sub> at 5 nC (%)    | 1.62           | 1.97           | 2.30           | 2.54           |
| Final rms bunch length (mm)   | 1.04           | 1.04           | 1.03           | 1.03           |
| Final single bunch $\Delta E/E$ (%)                                     | 0.13           | 0.13           | 0.12           | 0.12           |
| Final offset centroid $\Delta E/E$ reference B <sub>1</sub> at 5 nC (%) | 0.14           | 0.21           | 0.29           | 0.36           |
| Final centroid $\Delta t$ from B <sub>1</sub> at 5 nC (ps)              | -29.0          | -35.2          | -41.0          | -44.9          |

\*Slightly modification of the bunch length compatible with the other aspects

**Outcomes:**

- Fixed and unique “golden pulse” for all the charges
- Not necessary a LLRF system adapting for each charge combination

**Price to pay:**

- We need higher voltage compared to the use in single-bunch mode (combination of over- and under-compression)
- We lose in flexibility: single-bunch and multi-bunch are not disentangled

**Questions:**

- Is the time delay 5 pC vs 5 nC bunch acceptable? It seems the case (booster/injection). Confirmed?
- Is the different bunch length 5 pC vs 5 nC acceptable? It seems the case (booster). Confirmed?



## Transverse Dynamics: dynamic effects

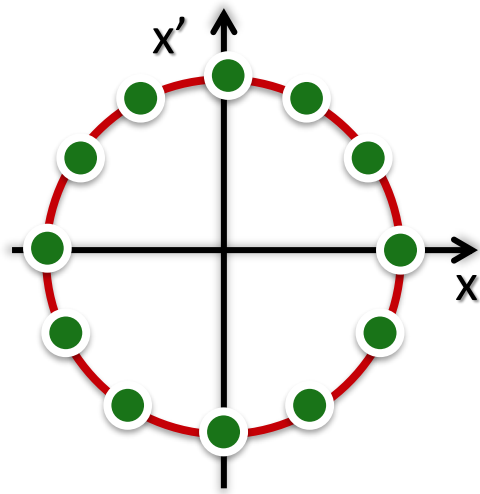
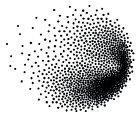

● Bunch

*Approach already applied to the CLIC design*

### Jitter amplification computation:

- Single bunches distributed on a circle injected to the line with different  $(x, x')$  or  $(y, y')$
- Computed the area in the initial beam transverse phase space  $\rightarrow A_0$
- Computed the area in the final beam transverse phase space  $\rightarrow A_F$
- Jitter amplification, JA, is defined as the square root of the ratio of the areas  $\rightarrow \sqrt{A_F/A_0}$

### Advantages of this approach:

- JA is **independent** on the initial jitter (from the gun section presently  $0.12 \cdot \sigma_x$  assumed 200 MeV from AWAKE at CERN)
- JA considers the effect on the **full transverse phase space**, and not only in  $x$  OR  $x'$  ( $y$  or  $y'$ )  $\rightarrow$  it does not depend on the location where it is determined (beam waist or any other Twiss alpha)
- Given JA of a generic  $k^{\text{th}}$  section,  $JA_k$ , the **total jitter amplification**  $JA_{tot}$  is given by the product of all of them

$$JA_{tot} = \prod_{k=1}^N JA_k$$

- Given the initial jitter  $Jitter_0$ , the **jitter at a given location  $s$**   $Jitter(s)$  is computed as:

$$Jitter(s) = Jitter_0 \cdot JA_{tot}$$

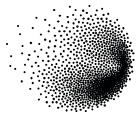

## ■ Simulations' strategy: provide specifications for the RF design

- Imposed a kick to the second bunch to simulate the long-range wakefield generated by the first bunch to the following one → independent on the bunch **time** separation
- Determined the **tolerable kick** to maintain the JA below the defined threshold
- RF design target to produce transverse wakefield below this value

→ This method is independent on the minimum bunch separation → applicable from the early design phase

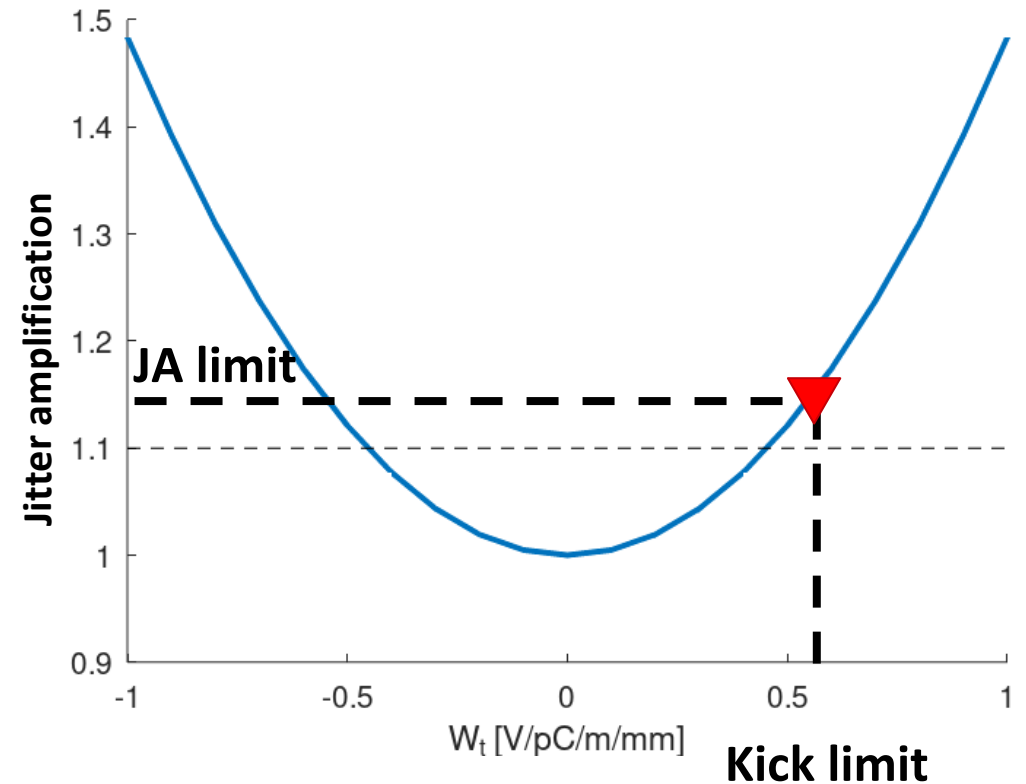
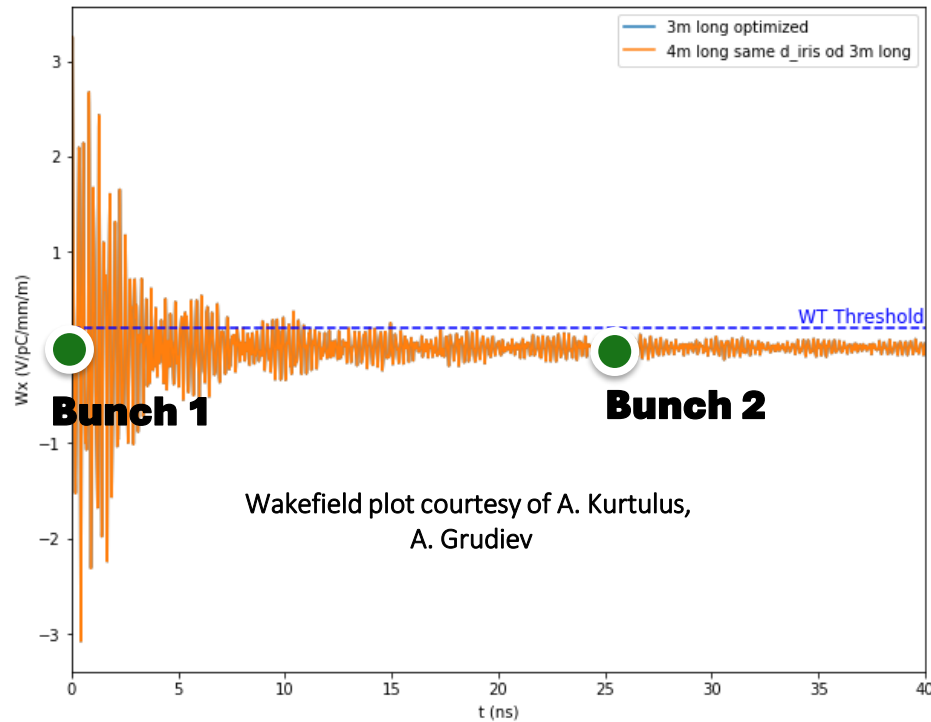

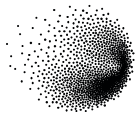

PSI

# Multi-bunch, jitter amplification: results

Layout B

$$Jitter(s) = Jitter_0 \cdot JA_{tot}(s)$$

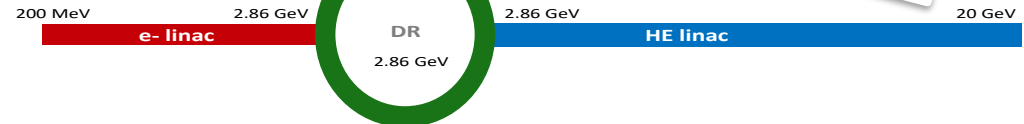

$$JA_{tot} = \prod_{k=1}^{N \text{ sections}} JA_k = \prod_{k=1}^N JA_{Multi}^k(s) \cdot JA_{Single}^k(s)$$

$$JA_{Multi} = JA_{eLin} \cdot JA_{Kicker \ inj} \cdot JA_{DR} \cdot JA_{Kicker \ extr} \cdot JA_{HELin}$$

DR group

Injection/extraction group

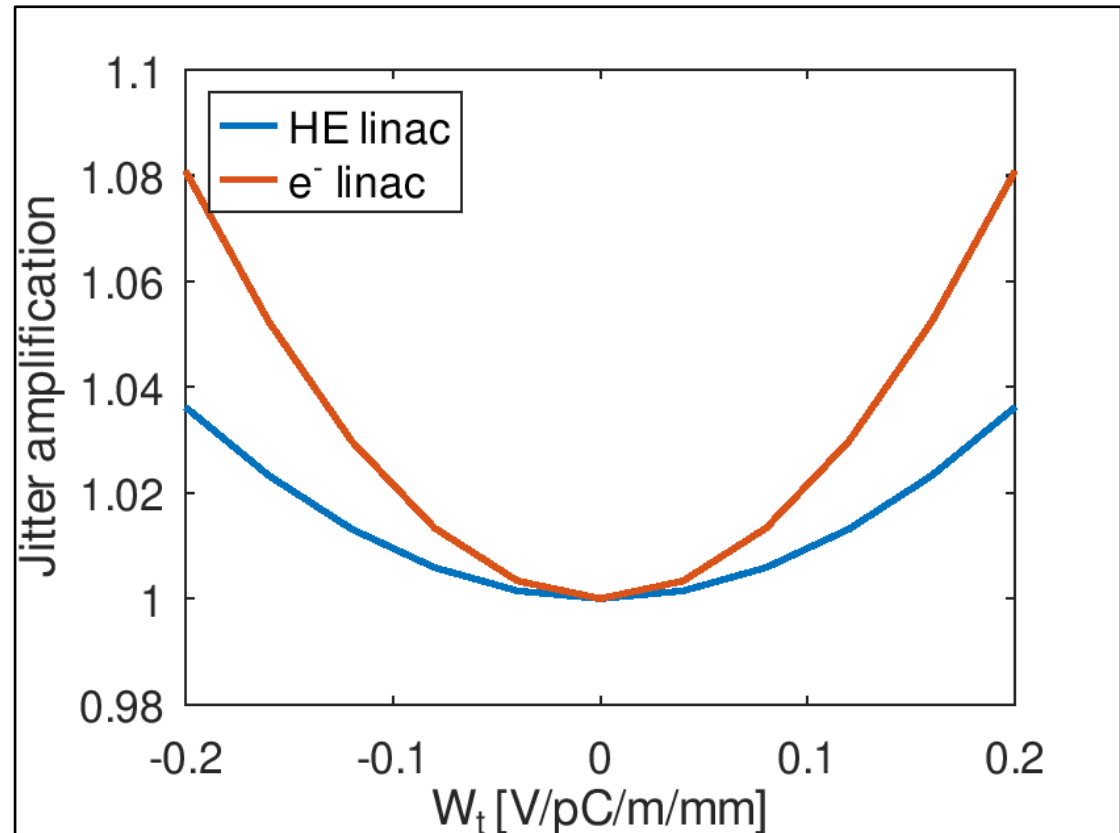
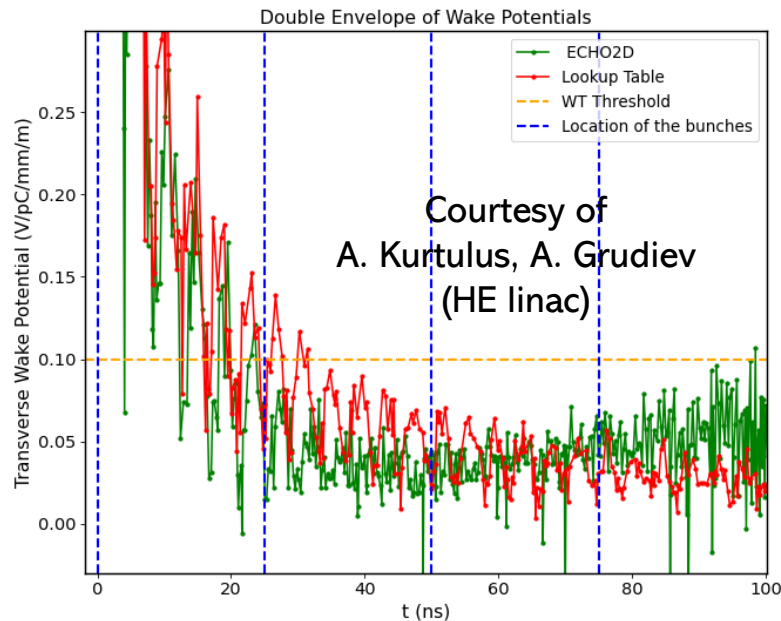

Initial jitter amplified by 5% assuming kick = 0.1 V/pC/m/mm (only linacs)

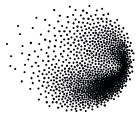

## Simulation setup:

- Compute the JA along the considered linac
- Determine the JA at the end of the considered linac
- Given the maximum acceptable jitter, determine the specifications for the RF design

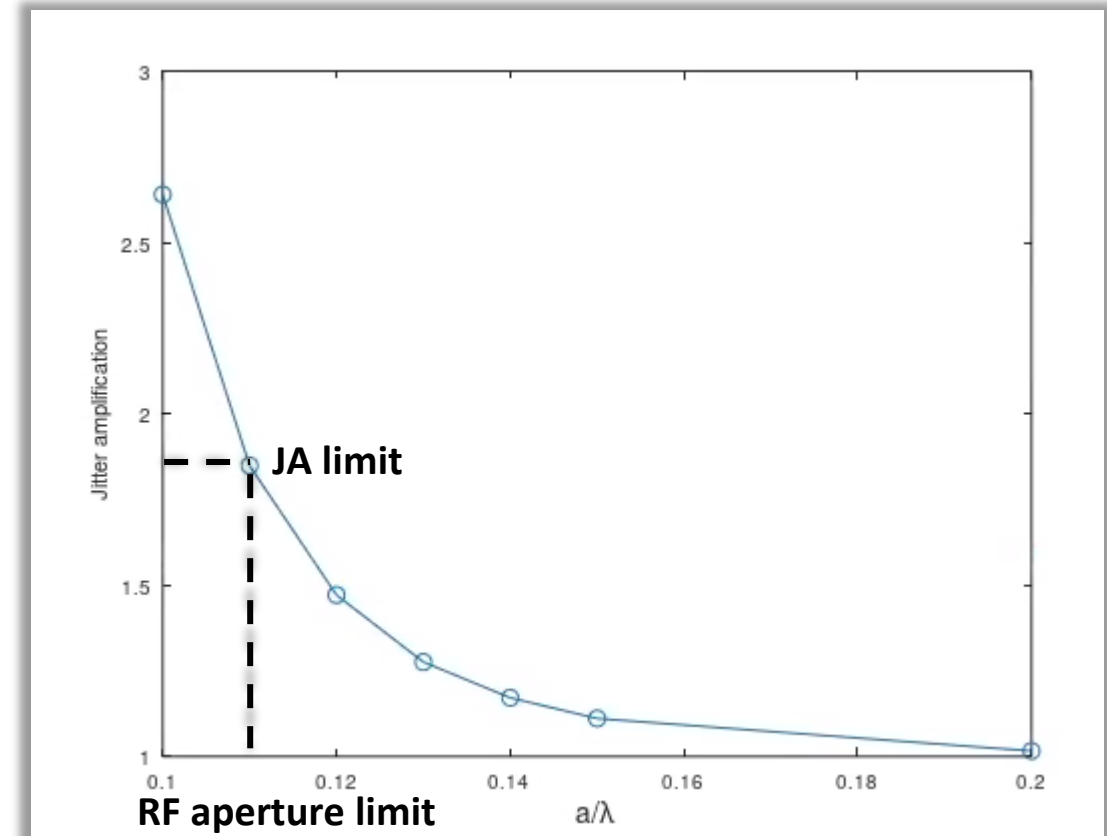
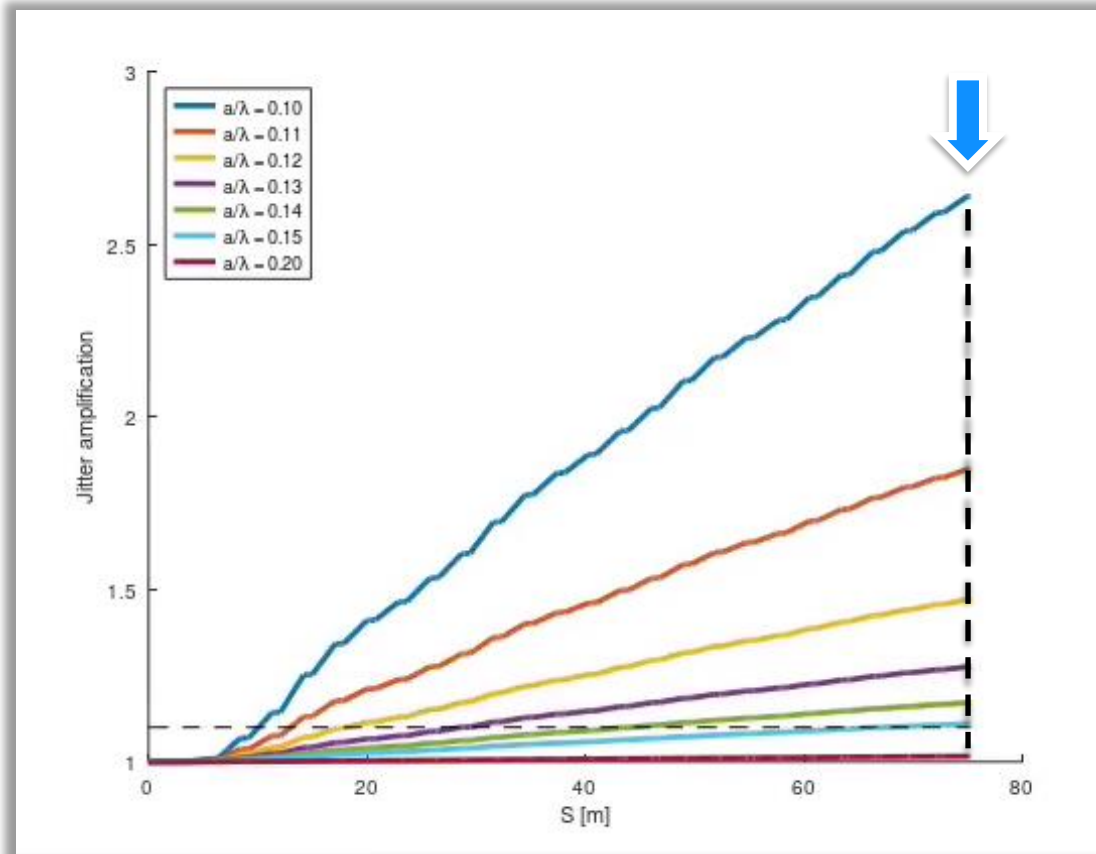

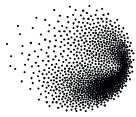

Jitter limitations for:

- Positron production
- Damping ring: efficient injection and capture

|            | a (mm) | d <sub>quad</sub> = 3.75 m | d <sub>quad</sub> = 4.75 m |
|------------|--------|----------------------------|----------------------------|
| a/λ = 0.10 | 10.71  | 7.13                       | 11.66                      |
| a/λ = 0.12 | 12.86  | 2.66                       | 3.70                       |
| a/λ = 0.15 | 16.07  | 1.38                       | 1.58                       |

TABLE III. FCC-ee electron linac final jitter amplification as a function of a assuming different distances among the quadrupoles.

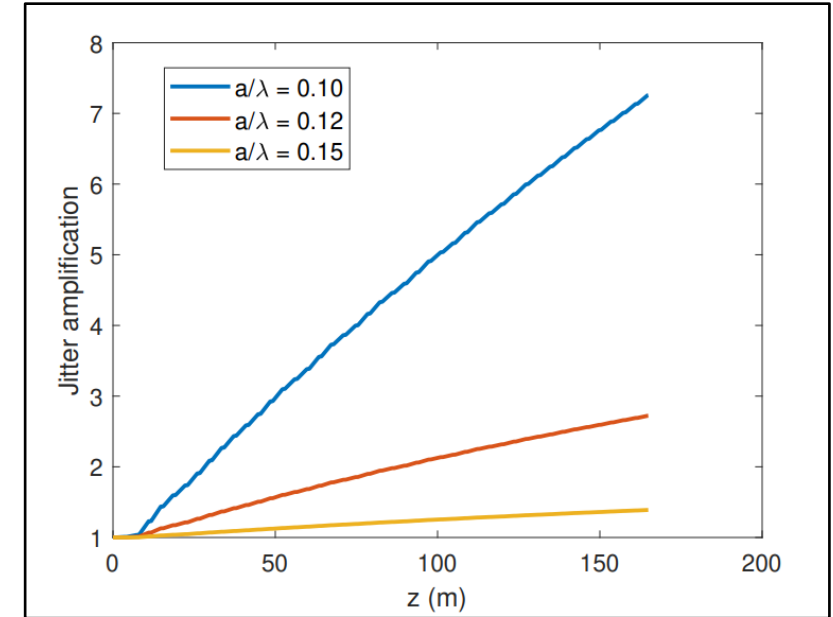

Positron production (F. Alharti, I. Chaikovska):

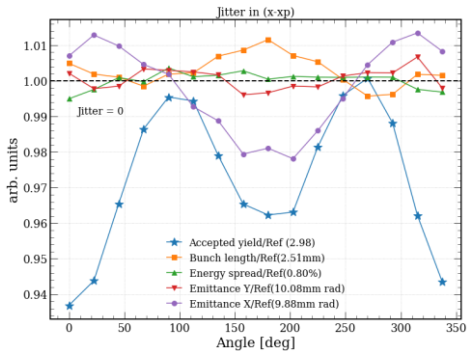

- Initial jitter of 0.12% · σ<sub>x,y</sub> (AWAKE injector-similar conditions)
- Transverse phase space painting technique applied
- GEANT4 simulations defined the acceptable JA → a/λ = 0.15 corresponds to a tolerable yield drop, presently a/λ = 0.12 not acceptable

Damping ring:

- Large acceptance for the e+ bunches, so margin expected also for the e- (much smaller beam size)
- DR group will provide the calculations once their design will be mature

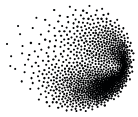

Jitter limitations for:

- Transport through the transfer line
- Efficient booster injection and capture

|                   | a (mm)       | d <sub>quad</sub> = 3.75 m | d <sub>quad</sub> = 4.75 m |
|-------------------|--------------|----------------------------|----------------------------|
| a/λ = 0.10        | 10.71        | 1.21                       | 1.88                       |
| a/λ = 0.11        | 11.76        | 1.06                       | 1.52                       |
| <b>a/λ = 0.12</b> | <b>12.86</b> | <b>0.98</b>                | 1.31                       |

TABLE IV. FCC-ee HE linac final jitter amplification as a function of a assuming different distances among the quadrupoles.

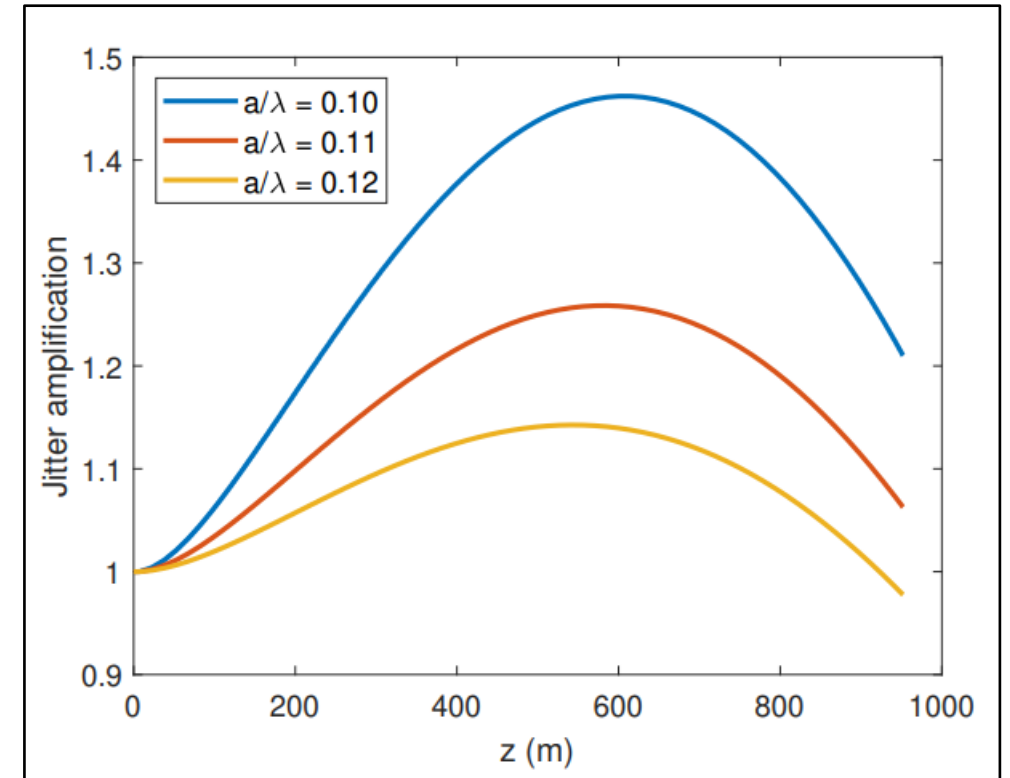

Outcomes:

- Selected **a/λ = 0.12** (also considering the static effects on the emittance preservation)
- Jitter not increased or even reduced compared to the initial one at the exit of the HE linac
- This conclusion relies on a **strong reduction** of the jitter amplification. Which is the mechanism?

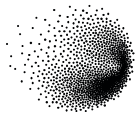

VLEPP: TRANSVERSE BEAM DYNAMICS  
 V.E.Balakin, A.V.Novokhatsky and V.P.Smirnov  
 Institute of Nuclear Physics, Novosibirsk, USSR

Jitter suppression condition →

$$\frac{\Delta v}{v} \geq \frac{G}{2E_0 v_0^2}$$

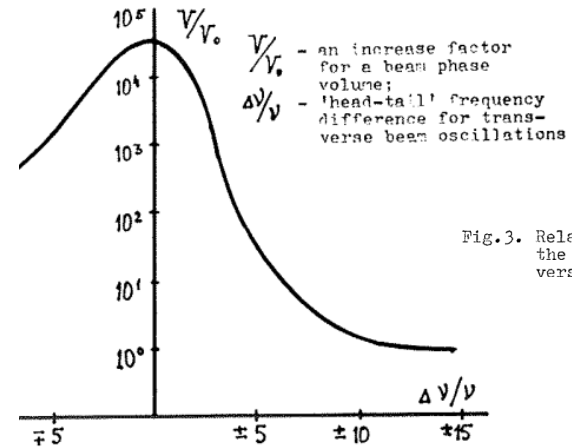

Fig.3. Relative phase volume at the exit of the accelerator's 100 GeV section versus the initial energy spread.

Some RF structures operated off-crest



Energy variation along the bunch



Different frequency of betatron oscillation (different phase advances)



«Bunch» jitter damped

## BEAM DYNAMICS IN SLC<sup>1</sup>

Ralph W. Assmann

Stanford Linear Accelerator Center, Stanford University, Stanford CA 94309

Using the *slope of the accelerating RF*, an energy difference is between head and tail is induced ("correlated energy spread"). With a proper choice of RF phases, the defocusing wakefield effects for the tail can then be cancelled by chromatic effects from the quadrupoles.

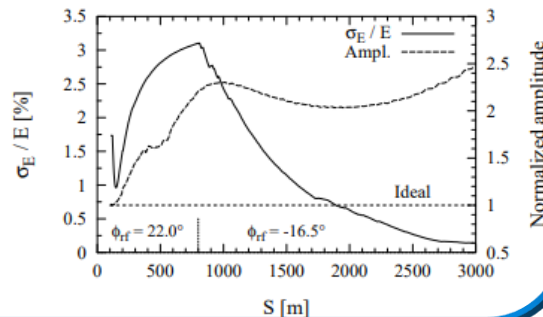

## Measured Optimum BNS Damping Configuration of the SLC Linac\*

J. T. Seeman, F.-J. Decker, R. L. Holtzapple, W. L. Spence

Stanford Linear Accelerator Center  
Stanford University, Stanford, California 94309 USA

A technique to reduce the resonant blowup of the tail by the head is called BNS damping, where *the energy of the longitudinal tail of the bunch is reduced from that of the head by offsetting the initial RF phases*. With this technique, the net "defocusing" transverse wakefield forces on the tail are to a large extent canceled by the increased focusing of the quadrupole lattice for the tail

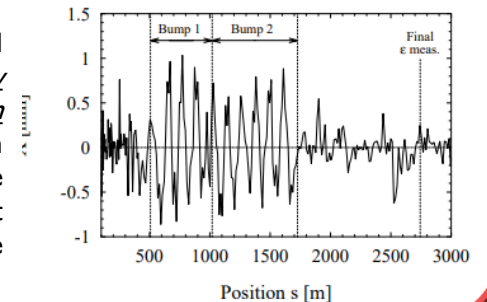

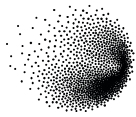

Obtain enough energy variation along the bunch to initiate the same mechanism as BNS damping does, BUT using the RF induced energy spread AND the longitudinal wakefield → optimization of the RF structure aperture and bunch length

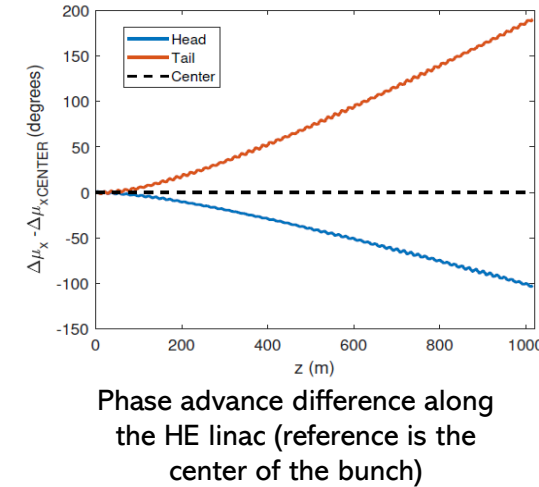
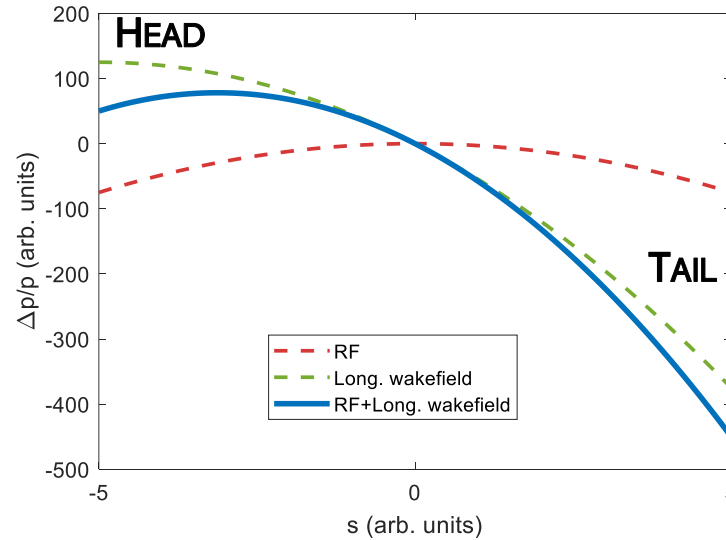
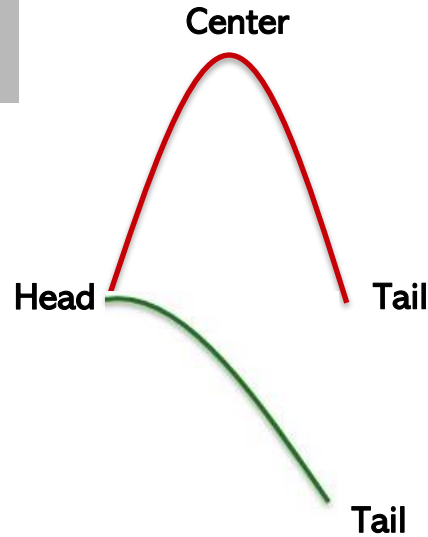

Rms energy spread along the bunch at the exit of the HE linac

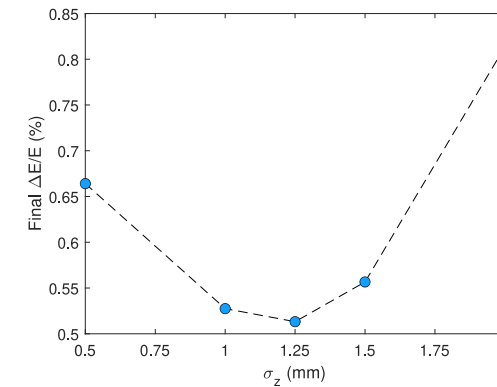

Same mechanism as the BNS damping but:

- On-crest operation → more energy **efficient**, and better transverse beam **quality** preservation
- Relatively long bunch length → advantageous for the **initial** transverse emittance, and minimization of the **longitudinal** beam **manipulation** keeping a reasonable energy spread

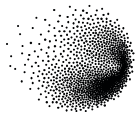

$$Jitter(s) = Jitter_0 \cdot JA_{tot}(s)$$

$$JA_{tot} = \prod_{k=1}^N JA_k = \prod_{k=1}^N JA_{Multi}^k(s) \cdot JA_{Single}^k(s)$$



## Multi-bunch

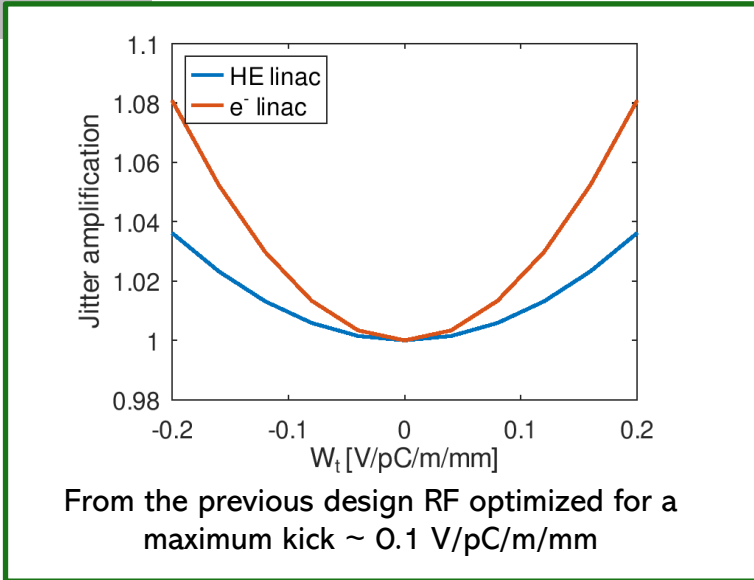

## Single bunch

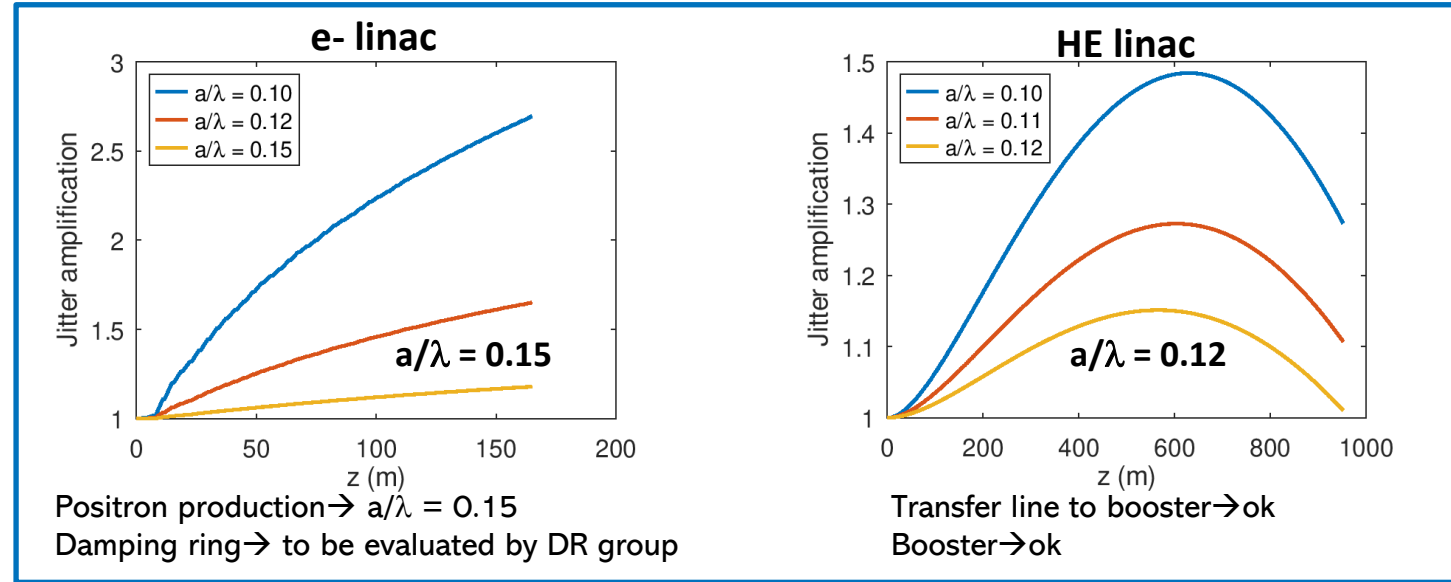

| e- linac    |              | HE linac    |              |
|-------------|--------------|-------------|--------------|
| Multi-bunch | Single bunch | Multi-bunch | Single bunch |
| 1.02        | 1.38         | 1.03        | 0.98         |

### Total JA only linacs = 1.32

(neither DR damping nor injection/extraction elements included)

$$Jitter(s) = 1.12 \cdot \sigma_{x/y} \cdot JA_{tot}(s) \sim 1.5 \cdot \sigma_{x/y}$$

(maximum final tolerated value is  $2 \cdot \sigma_{x/y}$ )

During the last year(s) the injector complex has been optimized in term of cost and power

- Power consumption reduced by more than a factor 3 and machine reliability improved with the last modification
  - New RF structure design
  - Lower gradient, repetition rate, average and peak power



- Transverse dynamics (static): emittance growth
  - Defined the RF structures aperture along all the linacs
  - Achieved **40% margin** on the target emittances for the booster injection
- Transverse dynamics (dynamic): jitter
  - The full linac chain (single and multi-bunch) has an acceptable transverse jitter amplification for the injection to the booster
  - Used a kind of “BNS damping” which even reduces the jitter at the HE linac exit, AND operating on-crest the RF cavities

- Longitudinal dynamics: energy spread and bunch length
  - Without the energy compressor: solution with RF cavities operated around 10 degrees **off-crest** (worse for acceleration efficiency and transverse emittance growth)
  - With the energy compressor: RF cavities operated **on-crest**, target parameters achieved (with even a margin for the energy spread), and independently tunable without varying the linac’s settings (important for the bunch charge scan)
  - Multi-bunch: presented the results corresponding to the possibility of using the EC also for the beam loading compensation, to avoid the implementation of a LLRF system adjusting for each charge variation (scan from “0” nC to 5 nC)

**The present design fulfills the design requirements with some margin**

**Experimental tests to verify some of the outcomes from the simulations are essential**

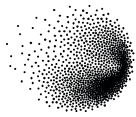

PSI

# Acknowledgments...



...to the entire WP1,  
the booster and the transfer line and  
booster WPs ...

...CHART\* and you for your attention

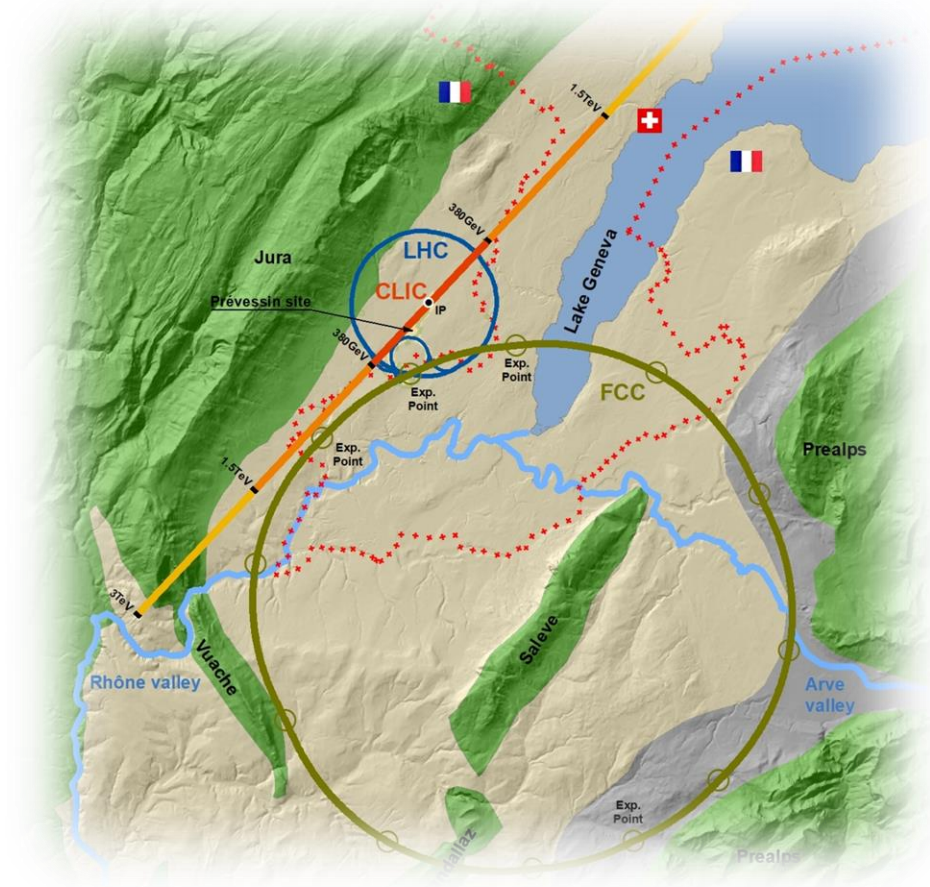

\*This work was done under the auspices of CHART (Swiss Accelerator Research and Technology) Collaboration



FCCIS: 'This project has received funding from the European Union's Horizon 2020 research and innovation programme under the European Union's Horizon 2020 research and innovation programme under grant agreement No 951754.'

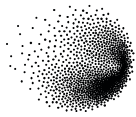

PSI

# Credits



|                 |   |
|-----------------|---|
| <b>PSI</b>      | B. Auchmann, I. M. Besana, S. Bettoni, P. Craievich, M. Duda, R. Fortunati, H. Garcia-Rodrigues, D. Hauenstein, R. Ischebeck, P. Juranic, J. Kosse, F. Marcellini, U. Michlmayr, G. L. Orlandi, M. Pedrozzi, J.-Y. Raguin, S. Reiche, R. Rotundo, S. Sanfilippo, M. Schär, N. Strohmaier, N. Vallis, M. Zykova, R. Zennaro, H.H. Braun, M. Seidel<br>all the technical groups involved in the P3 experiment |
| <b>IJCLab</b>   | F. Alharthi, R. Chehab, I. Chaikovska, V. Mytrochenko, Y. Wang  |
| <b>CERN</b>     | W. Bartmann, H. Bartosik, M. Calviani, S. Doebert, Y. Duthell, J. L. Grenard, A. Grudiev, B. Humann, A. Kurtulus, A. Latina, A. Lechner, R. Mena Andrade, A. Perillo Marcone, K. Oide, Y. Zhao, F. Zimmermann, Z. Vostrel, M. Benedikt  |
| <b>INFN-LNF</b> | C. Milardi, A. De Santis, O. Etisken, S. Spampinati   |
| <b>SLAC</b>     | T. Raubenheimer   |
| <b>KEK</b>      | Y. Enomoto, K. Furukawa   |
|                 | and L. Bandiera, M. Soldani, A. Sytov (INFN/Ferrara), A. Bacci, M. Rossetti Conti (INFN/Milano)   |



This work was done under the auspices of CHART (Swiss Accelerator Research and Technology) Collaboration, <https://chart.ch> - **CHART Scientific Report:** <https://chart.ch/reports/>



FCCIS: 'This project has received funding from the European Union's Horizon 2020 research and innovation programme under the European Union's Horizon 2020 research and innovation programme under grant agreement No 951754.'

During the last year(s) the injector complex has been optimized in term of cost and power

- Power consumption reduced by more than a factor 3 and machine reliability improved with the last modification
  - New RF structure design
  - Lower gradient, repetition rate, average and peak power



- Transverse dynamics (static): emittance growth
  - Defined the RF structures aperture along all the linacs
  - Achieved **40% margin** on the target emittances for the booster injection
- Transverse dynamics (dynamic): jitter
  - The full linac chain (single and multi-bunch) has an acceptable transverse jitter amplification for the injection to the booster
  - Used a kind of “BNS damping” which even reduces the jitter at the HE linac exit, AND operating on-crest the RF cavities

- Longitudinal dynamics: energy spread and bunch length
  - Without the energy compressor: solution with RF cavities operated around 10 degrees **off-crest** (worse for acceleration efficiency and transverse emittance growth)
  - With the energy compressor: RF cavities operated **on-crest**, target parameters achieved (with even a margin for the energy spread), and independently tunable without varying the linac’s settings (important for the bunch charge scan)
  - Multi-bunch: presented the results corresponding to the possibility of using the EC also for the beam loading compensation, to avoid the implementation of a LLRF system adjusting for each charge variation (scan from “0” nC to 5 nC)

**The present design fulfills the design requirements with some margin**

**Experimental tests to verify some of the outcomes from the simulations are essential**

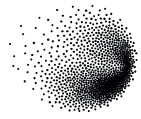

**PSI**

SPARES



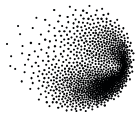

PSI

# More about EC

### Exit HE linac – 5 nC

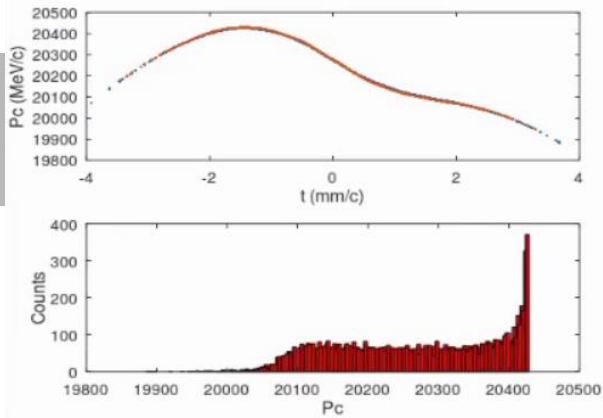

### Scan of the voltage (exit EC)

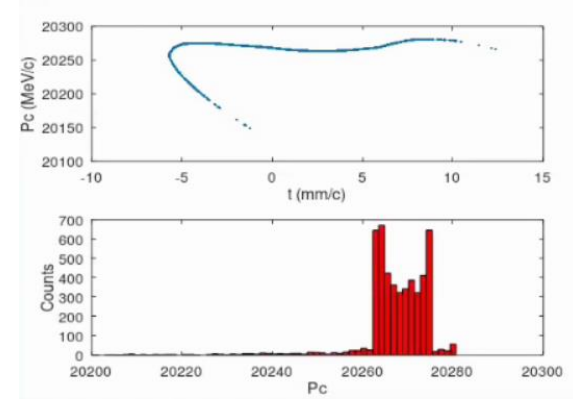
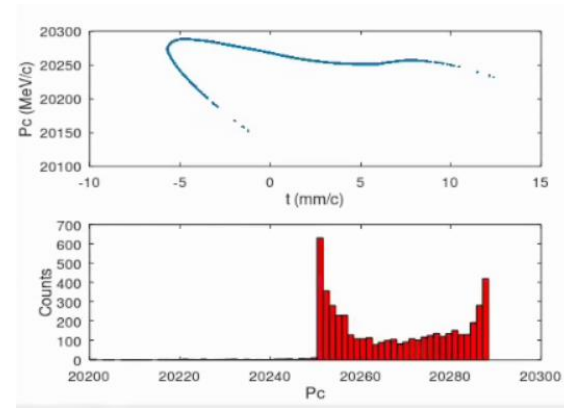
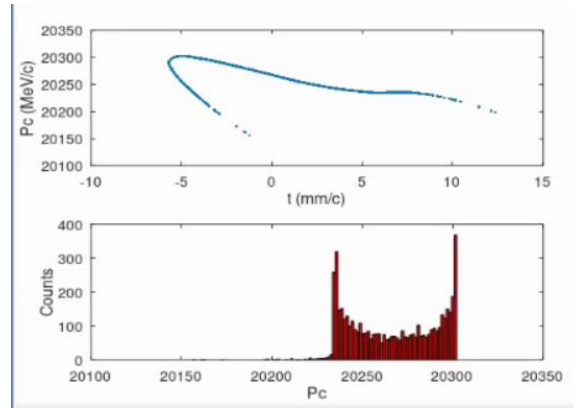

### Exit HE linac – 5 pC

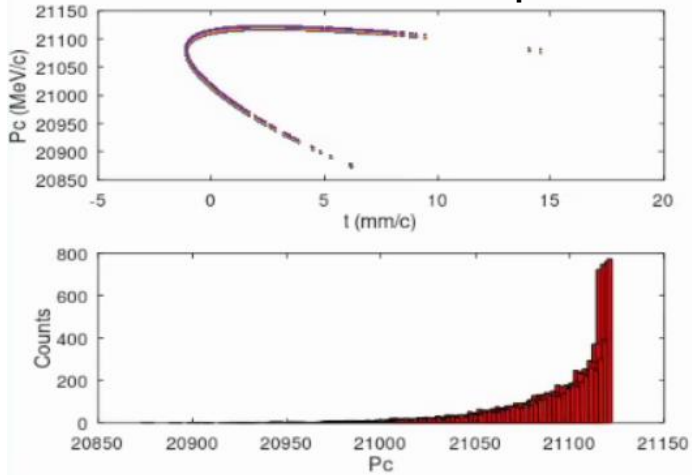

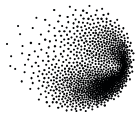

PSI

# Setting Common (S-band) and HE Linac **on-crest**

$$V_2 = \frac{\lambda_2 E}{2q\pi R_{56}}$$

At the HE Linac exit

At the EC exit

HE Linac S-band

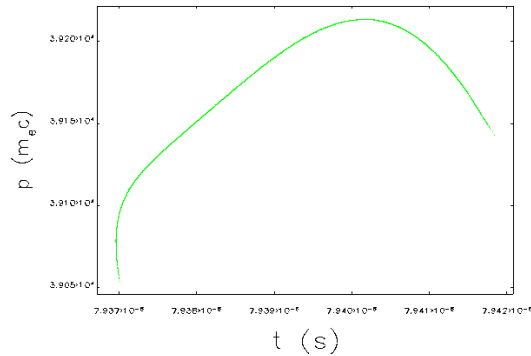
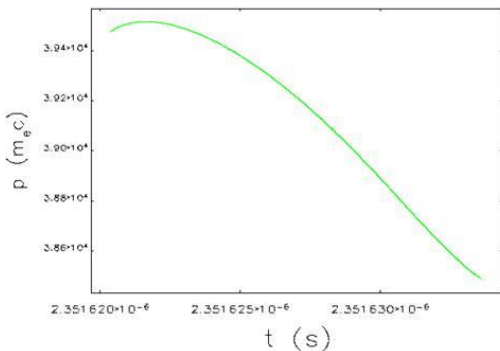

HE Linac C-band

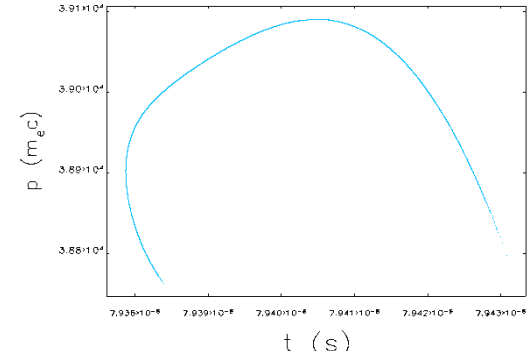
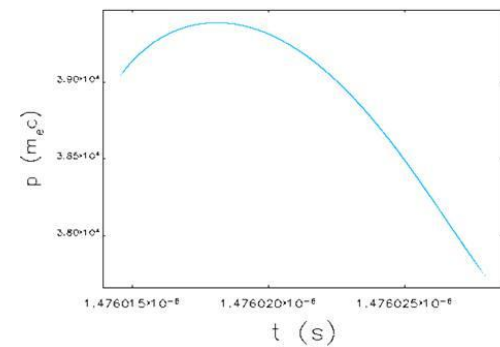

|                        | HE linac S-band<br>(G = 25 MV/m) | HE linac C-band<br>a/λ = 0.20<br>(G = 40 MV/m) | HE linac C-band,<br>a/λ = 0.19<br>(G = 29 MV/m) |
|------------------------|----------------------------------|--|---|
| Exit HE Linac δE/E (%) | 0.74                             | 1.1  | 1.3   |
| R <sub>56</sub> (m)    | 0.41                             | 0.28   | 0.28  |

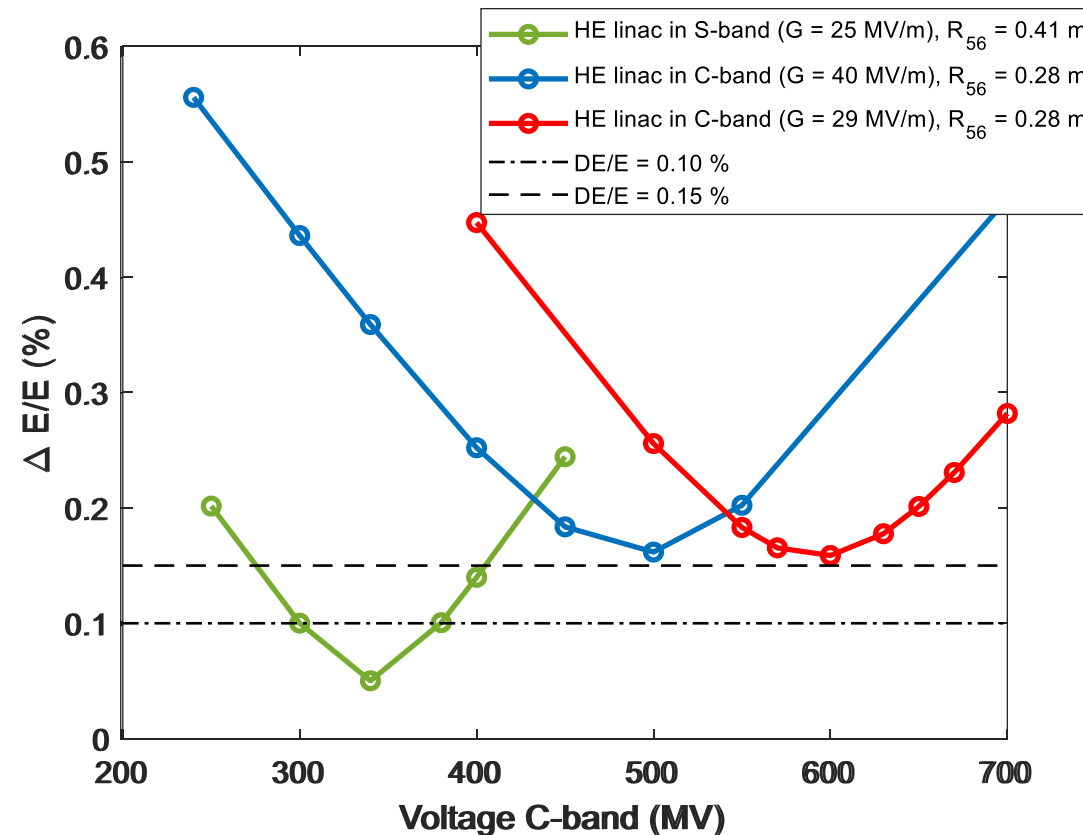

Assumed target bunch length = 4 mm (longer is even better for RF)

**S-band HE Linac on-crest:** δE/E = 0.05% achievable with 340 MV in C-band and 170 MV in X-band

**C-band HE Linac on crest:** minimum of δE/E limited to ~0.15% with 600 MV in C-band, 300 MV in X-band

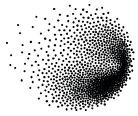

We use the well-known Karl Bane's model of the transverse and longitudinal short-range wakefield:

$$W_{\perp}(s) = \frac{4Z_0cs_{\perp 0}}{\pi a^4} \left[ 1 - \left( 1 + \sqrt{\frac{s}{s_{\perp 0}}} \right) \exp \left( -\sqrt{\frac{s}{s_{\perp 0}}} \right) \right]$$

$$W_{\parallel}(s) = \frac{4Z_0c}{\pi a^2} \exp \left( -\sqrt{\frac{s}{s_{\parallel 0}}} \right)$$

Where:

- $a$  is the structure's **iris aperture** radius
- $s$  is the distance from the witness to the wakefield source
- $s_{\parallel 0}$  and  $s_{\perp 0}$  are functions of the structure's geometry

The imparted kick is **proportional** to the **bunch charge**.

