



EPFL



FUTURE
CIRCULAR
COLLIDER



CHART
Swiss Accelerator
Research and
Technology



CERN



19-23 MAY
FCC
WEEK
2025



Nested Magnets and
Ballistic Optics for the
FCC-ee

**Cristóbal García-Jaimes¹, Tatiana Pieloni¹,
Leon van Riesen-Haupt¹, Mike Seidel¹,
Kyriacos Skoufaris² and Rogelio Tomás²**
¹ EPFL-LPAP ² CERN

This work was carried out under the auspices and with the support of the EPFL-Global Leaders, CHART and FCC-ee studies at CERN.

**May 20th 2025
FCC WEEK 2025**

An Alternative Optics Design: Integration of HTS-Nested Magnets in FCC-ee

- **Synchrotron Radiation (SR)** plays a key role in determining the overall performance and feasibility in accelerators. For FCC-ee, the limit is **50 MW per beam** in all operating modes.
- **SR is inversely proportional to the bending radius ρ** , and there is no additional space to add more dipoles in the FCC-ee baseline.
- Extend dipole field to quadrupoles and sextupoles to **increase the filling factor** and study an alternative optics using nested magnets.
- In collaboration with the CHART HTS4 project [1]— High Temperature Superconducting nested magnets which allows to have independently magnetic fields and gradients in the same element [2].

Energy
loss per
turn

$$\begin{aligned} \rightarrow U_0 &= \frac{e^2 \beta^3 \gamma^4}{3\epsilon_0 \rho}, \\ U_0 [eV] &= 2.65 \times 10^4 E^3 [GeV] B [T], \end{aligned}$$

HTS nested: dip+sext+quad

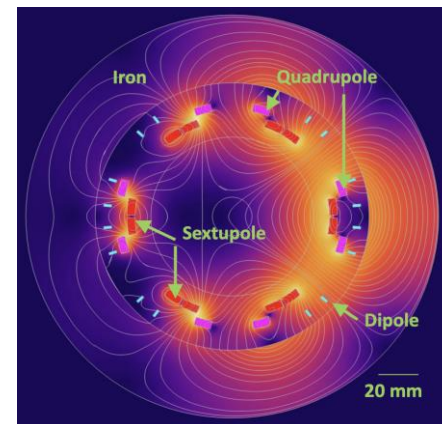

J. Kosse

Starting Simple: The FODO Cell as the Fundamental Unit

- The FODO cell is made of alternating focusing (QF) and defocusing (QD) quadrupoles, with dipoles in between.
- This structure is repeated throughout the FCC-ee arcs.
 - ◆ Nested Magnets (NMs) are implemented in quadrupoles and sextupoles, which occupy 14% of the arc.



$$B_{new} = B_{old} \frac{L_{dipoles}}{L_{dipoles} + L_{quadrupoles} + L_{sextupoles}}$$

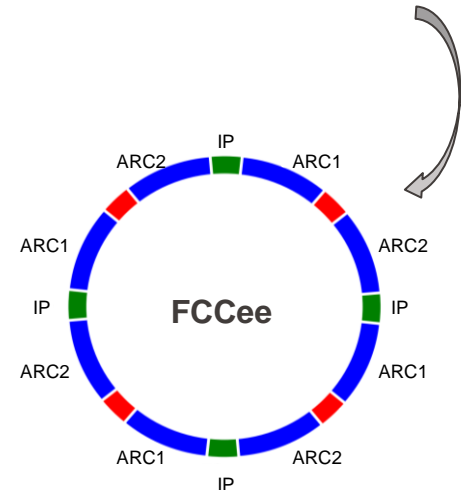

Equilibrium Emittance

- Introducing NMs modifies the Damping Partition Numbers (DPNs) due to the addition of a **dipolar field** to the quadrupoles.
- This affects the radiation integral I_4 , which is **dependent on the sign of k_1** :

$$I_4 = \oint \frac{D_x}{\rho} \left(2k_1 + \frac{1}{\rho^2} \right) ds$$

$$J_x = 1 - \frac{I_4}{I_2}, \quad \epsilon_x = C_q \frac{\gamma^2 I_5}{J_x I_2}$$

- The field in **QF c** e larger horizontal dispersion at QF. Meanwhile, a strong field can be applied in QD.
- To explore the options we define:
 - ◆ **Bf**: dipole field assigned to QF,
 - ◆ **B1**: field in main dipole and in QD.

We varied the ratio Bf/B1 to study its impact on emittance.

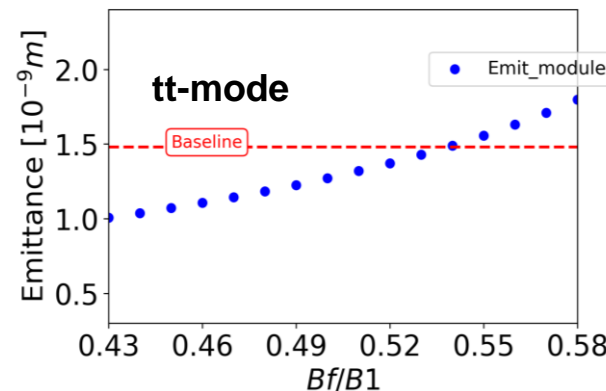
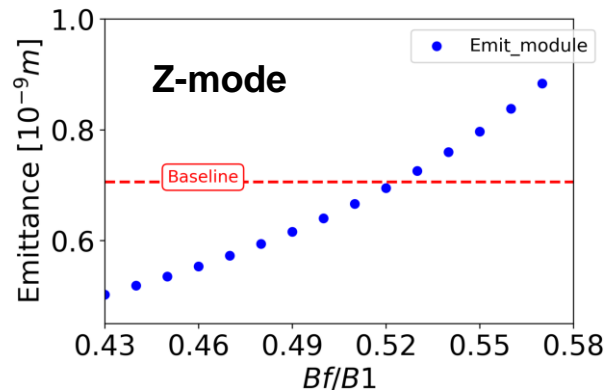

Shared Layout Between Z and tt modes

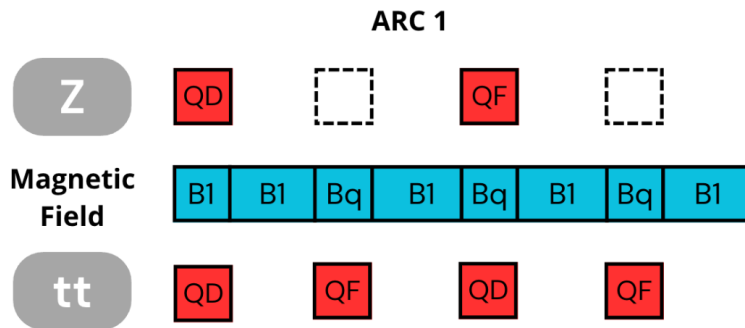

- In previous solutions [2–6], different magnetic fields were assigned to the QF and QD quadrupoles in tt and Z, leading to layout challenges.
- To avoid such complications, we explored a solution in which the dipole field distribution is identical in both lattices. The strategy is as follows:
 - ◆ If a slot is never occupied by a QF magnet, it is assigned the same magnetic field as the main dipoles (B1). Otherwise, it receives a reduced field, denoted as Bq.

Shared Layout Between Z and tt modes

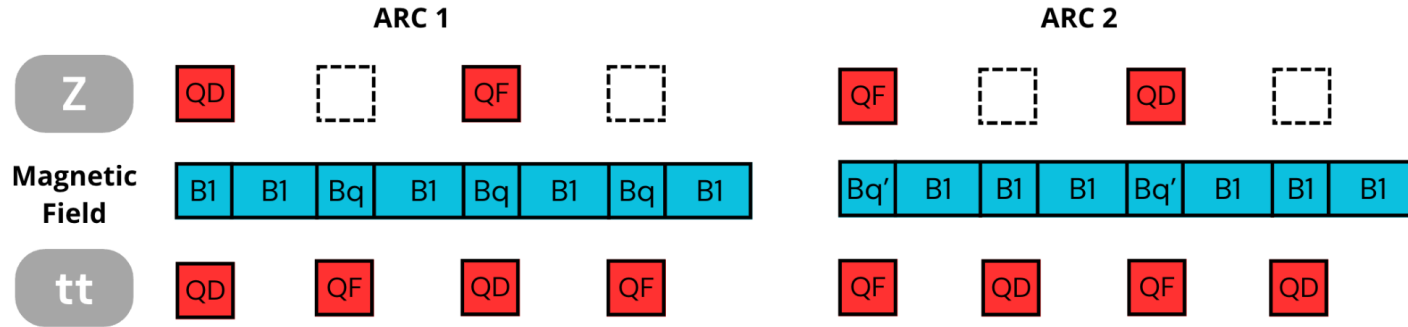

- Arc 1 and Arc 2 have different overlaps between the Z and tt configurations; as a result, Bq and Bq' differ. The relationship is given by: $Bq' = (3Bq - B1)/2$
- Although this approach resolves the layout incompatibilities, the emittance evolves slightly differently in each lattice.
 - ◆ This is because Bq' appears in both the QF and QD magnets in the Z configuration, whereas in the tt configuration it is applied only to the QF quadrupoles.

Z Lattice Optimization

- ❑ The primary objective is to **reduce U_0** by using different values of the **$Bq/B1$** ratio.
- ❑ As **$Bq/B1$** increases, the **emittance also grows**, which can impact the beam quality and luminosity.
- ❑ The **DPNs** evolve with the ratio. While their nominal values are **$(J_x, J_y, J_e) = (1, 1, 2)$** , the scan shows clear deviations.
- ❑ **Horizontal Damping time** increase with the ratio.
- ❑ **β** and dispersion beating less than 2%.

Selecting	Emittance [nm]	DPNs	U_0 Reduction [%]	Ratio $Bq/B1$
Reproduce Emittance	0.709	0.846 1 2.153	15.1	0.46
Reproduce DPNs	0.602	1 1 2	14.6	0.41
Min U_0	1.35	0.438 1 2.561	16.0	0.60

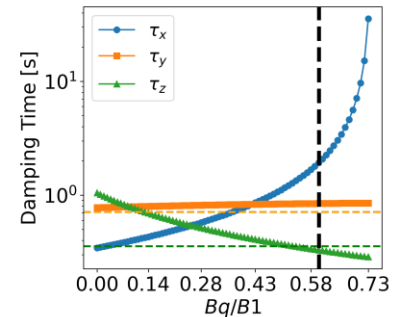
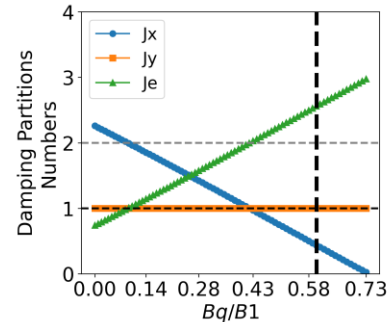
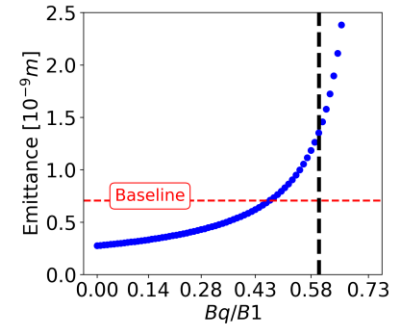
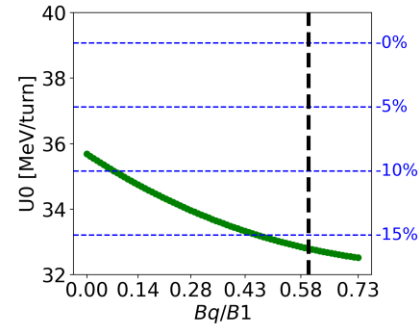

tt Lattice Optimization

- As in the Z lattice, similar behaviors are observed in the tt lattice.
- β and dispersion beating less than 1% compared to baseline.

Selecting	Emittance [nm]	DPNs	U0 Reduction [%]	Ratio Bq/B1
Reproduce Emittance	1.47	0.872 1.000 2.127	16.0	0.58
Reproduce DPNs	1.29	0.99 0.99 2.00	15.8	0.55

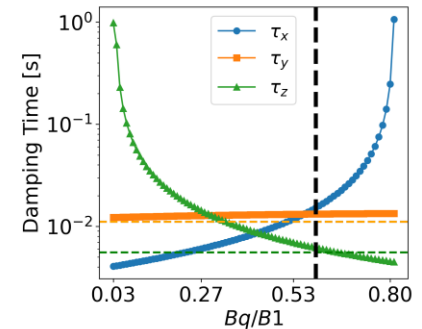
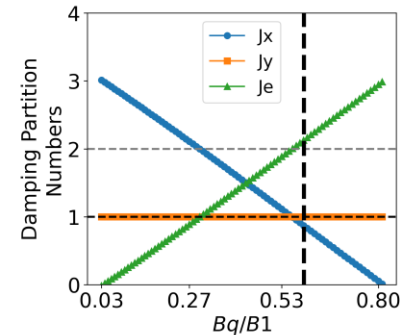
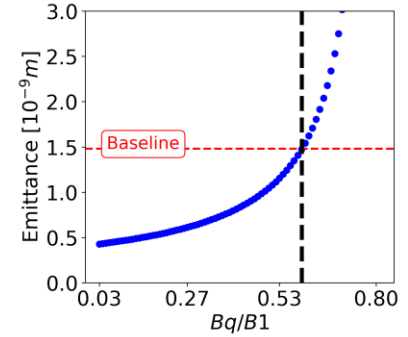
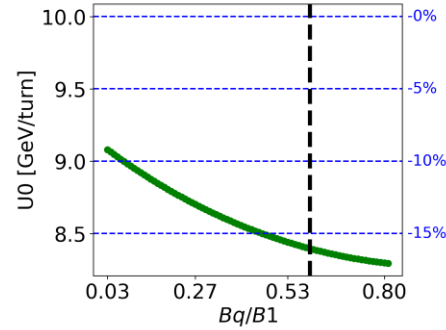

These configurations resolve the compatibility issues.

First Look at the Dynamic Aperture

- Installing the sextupoles at the nominal positions, results in two types of NMs: Dipole+Sextupole & Dipole+Quadrupole.



- The Dynamic Aperture (DA) presents significant challenges (better DA at larger Bq/B1 ratios) which should be addressed through sextupole optimization.
 - Additionally, it will be necessary to explore alternative configurations for sextupoles that may offer better performance.

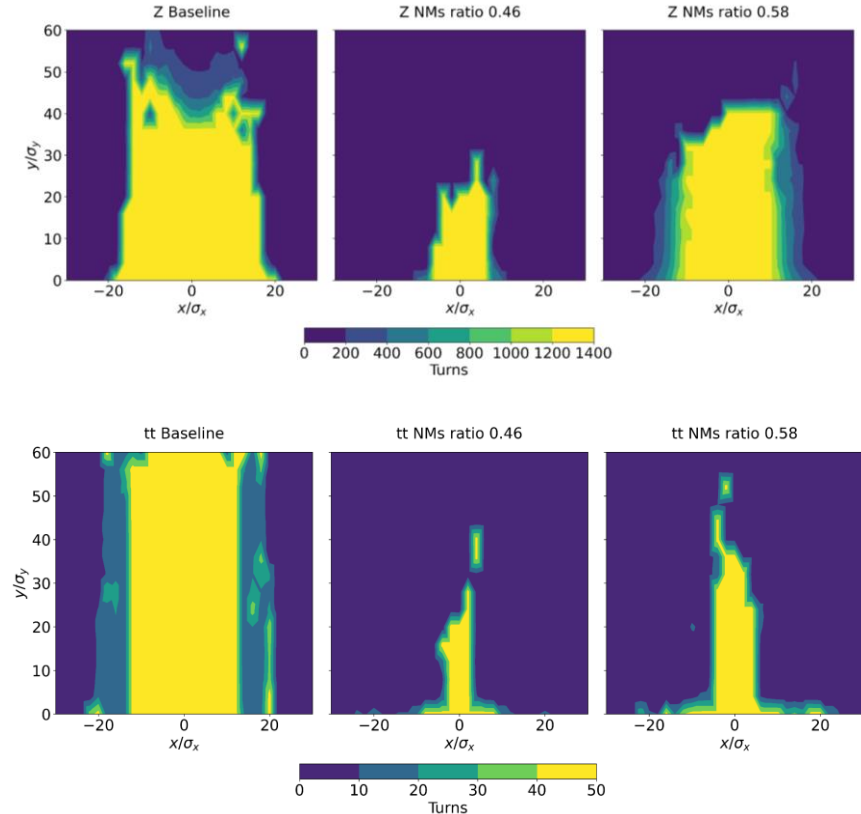

Summary and Outlook

- A new lattice design using nested magnets has been fully integrated in the GHC lattice.
- Beam stability was achieved by adjusting the dipole fields inside focusing quadrupoles. In parallel, layout compatibility issues between lattice configurations have also been resolved with the following advantages:
 - ◆ Only one arc dipole family is required, replacing the original three (B1, B1S, B1L).
 - ◆ This optics could also be feasible with Combined Function Magnets, but requires further studies.
 - ◆ NMs could achieve a range of around 15% reduction in Synchrotron Radiation power loss, contributing to a potential 20% decrease in the machine's total energy consumption [2].
- Future work to optimize DA and evaluate the impact on beam alignment and tuning flexibility.
- The LCC optics already feature a lower U_0 compared to the baseline design, and preliminary tests indicate that an additional 6% reduction can be achieved with the implementation of NMs, confirming the broader applicability of the concept.

Ballistic Optics for Commissioning (Z lattice)

Ballistic Optics for Z lattice

- Ballistic optics removes field gradients near the IP, allowing straight beam orbits for easier BPM alignment and calibration.
- It also has low chromaticity and no synchrotron radiation in the Final Doublet, making it ideal for initial tuning [7-8].

Baseline lattice

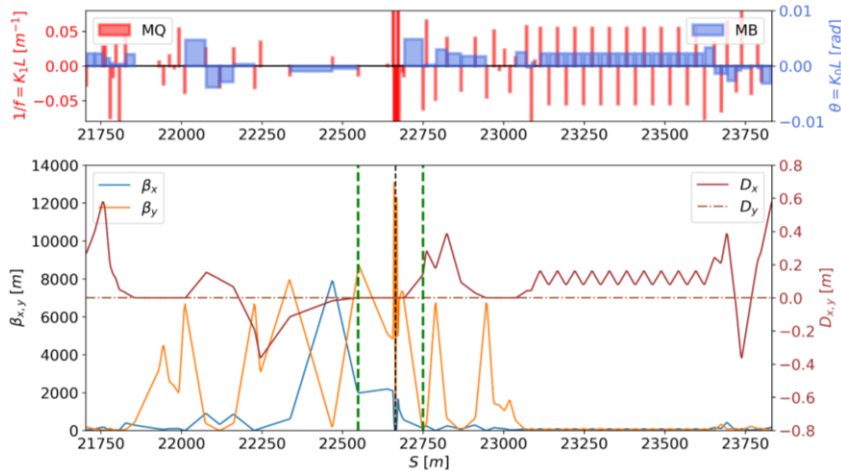

VS

Ballistic lattice

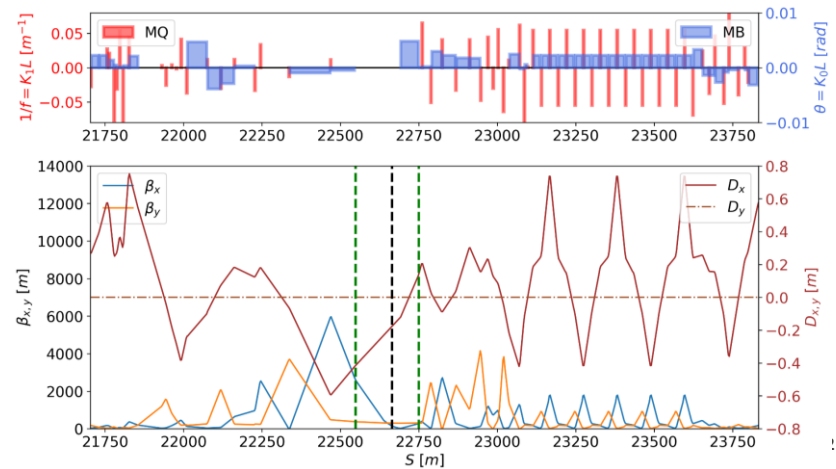

Ballistic Optics for Z lattice

Strategy:

- Select a Ballistic Region (BR) in the Interaction Region (IR) and **turn off the quadrupoles** there.
- Turn off all the sextupoles in the IR
- Rematching the BR in terms of Betas.

Baseline lattice

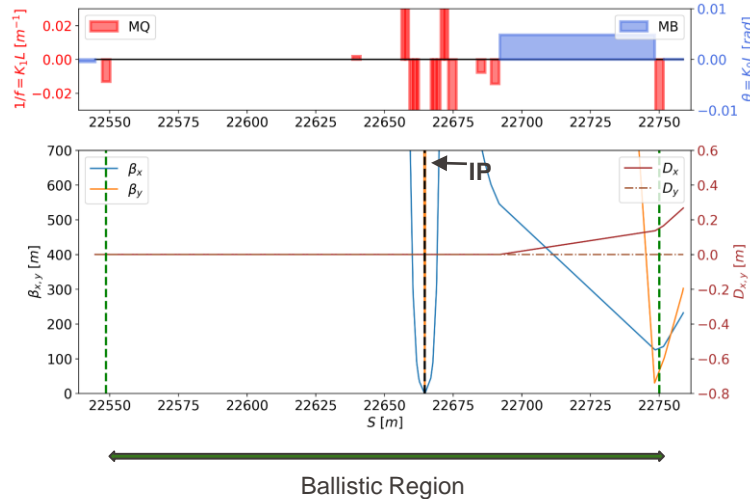

VS

Ballistic lattice

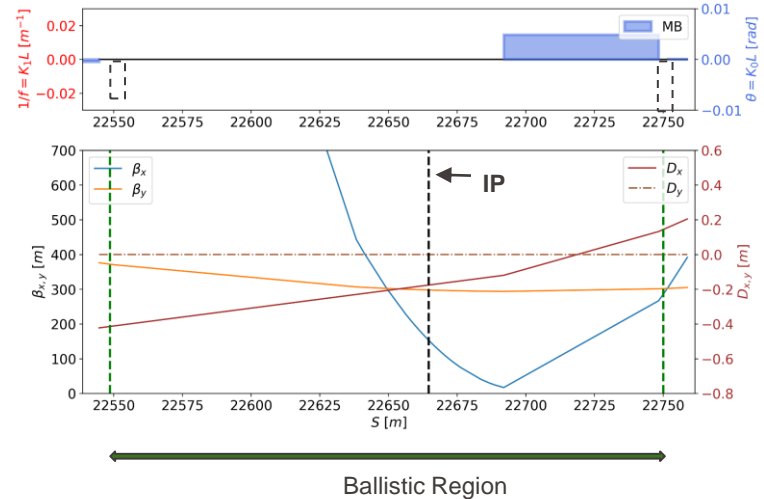

Momentum Acceptance & Dynamic Aperture

MA

Baseline V23

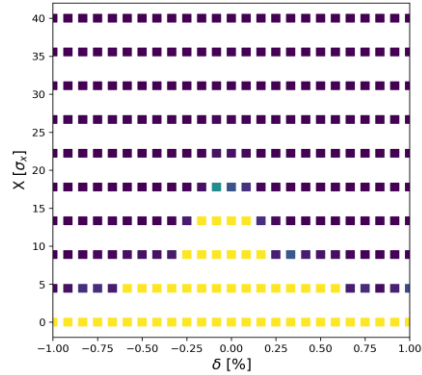

Baseline Ballistic Optics

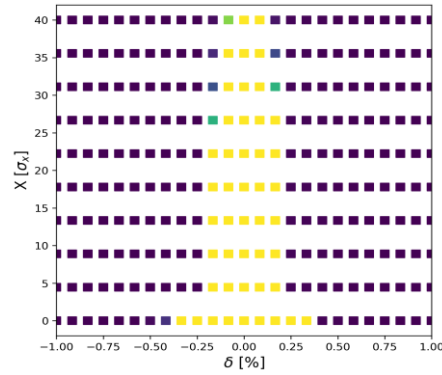

Optimized Ballistic Optics

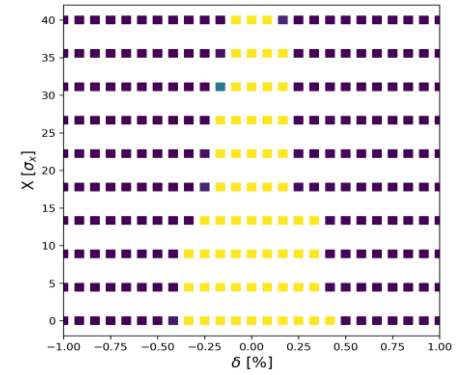

DA

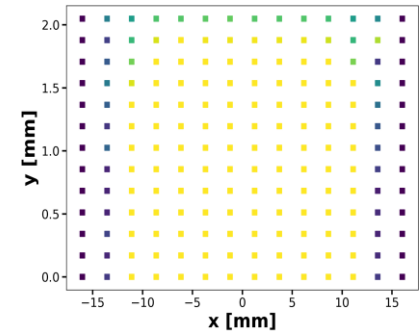
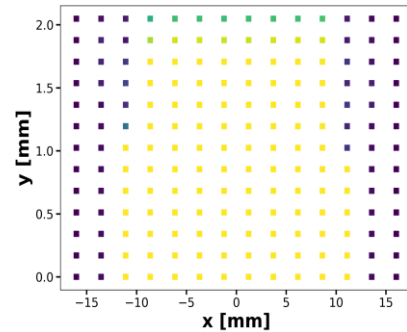
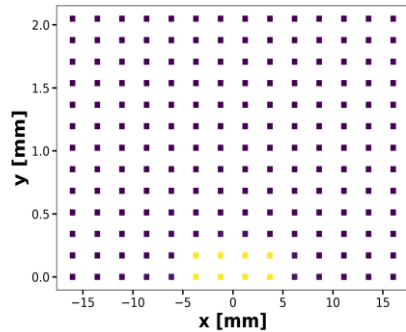

Conclusions and outlook

→ Ballistic Optics

- ◆ Ballistic optics feature a significantly larger DA, ideal for the early commissioning.
- ◆ It is possible to achieve improved ballistic optics by optimizing MA with the arc sextupole families, and the DA remains enhanced, more details [10].
- ◆ Future studies should focus on optimizing MA and Beam Lifetime.

References

- [1] HTS4 development. M. Koratzinos. FCCWeek2025
- [2] Kosse, J., Schmidt, J., Auchmann, B., Brem, A., Thabuis, A., & Koratzinos, M. (2024, septiembre 13). HTS4: Towards an energy-efficient FCC-ee. SPS2024, CERN. https://indico.cern.ch/event/1382917/contributions/6028543/attachments/2927303/5139183/2024_SPS HTS4_4.pdf
- [3] C. GARCIA JAIMES, L. van Riesen-Haupt, R. Tomas, and T. Pieloni, “Exploring FCCee optics designs with combined function magnets”, in Proc. 14th Int. Particle Accelerator Conf. (IPAC’23), Venice, Italy, May 2023, paper MOPL066, pp. 698-701.
- [4] C. GARCIA JAIMES, L. van Riesen-Haupt, M. Seidel, R. Tomas, and T. Pieloni, “Impact of dipole quadrupolar errors in FCC-ee”, in Proc. 14th Int. Particle Accelerator Conf. (IPAC’23), Venice, Italy, May 2023, paper MOPL065, pp. 694-697.
- [5] C. M. Garcia Jaimes, L. van Riesen-Haupt, M. Seidel, R. Tomas, and T. Pieloni, “First FCC-ee lattice designs with Nested Magnets”, presented at the 15th Int. Particle Accelerator Conf. (IPAC’24), Nashville, TN, USA, May 2024, paper WEPR10, this conference.
- [6] C. M. Garcia Jaimes, T. Pieloni, L. van Riesen-Haupt, M. Seidel, and R. Tomas, “First comparison studies in Dynamic Aperture for Nested Magnets and baseline lattice in the FCC-ee”, presented at the 15th Int. Particle Accelerator Conf. (IPAC’24), Nashville, TN, USA, May 2024, paper WEPR12, this conference.
- [7] C. M. Garcia Jaimes et al., “Parameter space for the magnetic design of Nested Magnets in the FCC-ee arc cell”, presented at the 15th Int. Particle Accelerator Conf. (IPAC’24), Nashville, TN, USA, May 2024, paper WEPR11, this conference.
- [8] Garcia Jaimes, C., van Riesen-Haupt, L., Pieloni, T., & Tomás, R. (2024, septiembre). Ballistic Optics for FCC-ee. CERN. <https://indico.cern.ch/event/1450442/contributions/6113015/attachments/2927766/5140223/Ballistic%20Optics%20tuning%20meeting.pdf>
- [9] Garcia Jaimes, C., Iadarola, G., Skoufaris, K., van Riesen-Haupt, L., Pieloni, T., & Tomás, R. (2024, noviembre). Update for Ballistic Optics. Presentación en la reunión de ajuste de óptica balística, CERN. Recuperado de <https://indico.cern.ch/event/1477971/contributions/6231754/attachments/2968140/5222652/Update%20for%20Ballistic%20Optics.pdf>
- [10] Integrated simulations for calculation of tolerances. K. Skoufaris. FCCWeek2025.



Merci

**Cristóbal M.
García-Jaimes**

FODO cell and Radiation Integrals

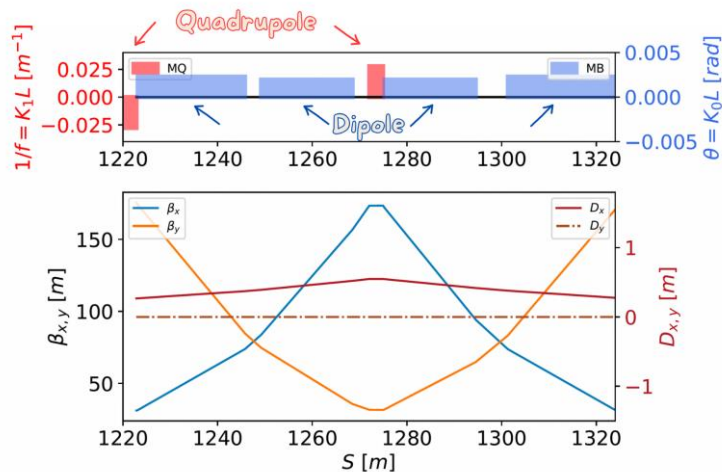

$$I_2 = \oint \frac{1}{\rho^2} ds ,$$

$$I_4 = \oint \frac{D_x}{\rho} \left(2 k_1 + \frac{1}{\rho^2} \right) ds ,$$

$$I_5 = \oint \frac{\mathcal{H}(s)}{|\rho^3|} ds ,$$

$$J_u = 1 - \frac{I_4}{I_2} ,$$

$$\epsilon_u = C_q \frac{\gamma^2}{J_u} \frac{I_{5u}}{I_2} ,$$

$$\tau_u = \frac{2E}{J_u U_0} T_0 ,$$

Optical Functions with Nested Magnets

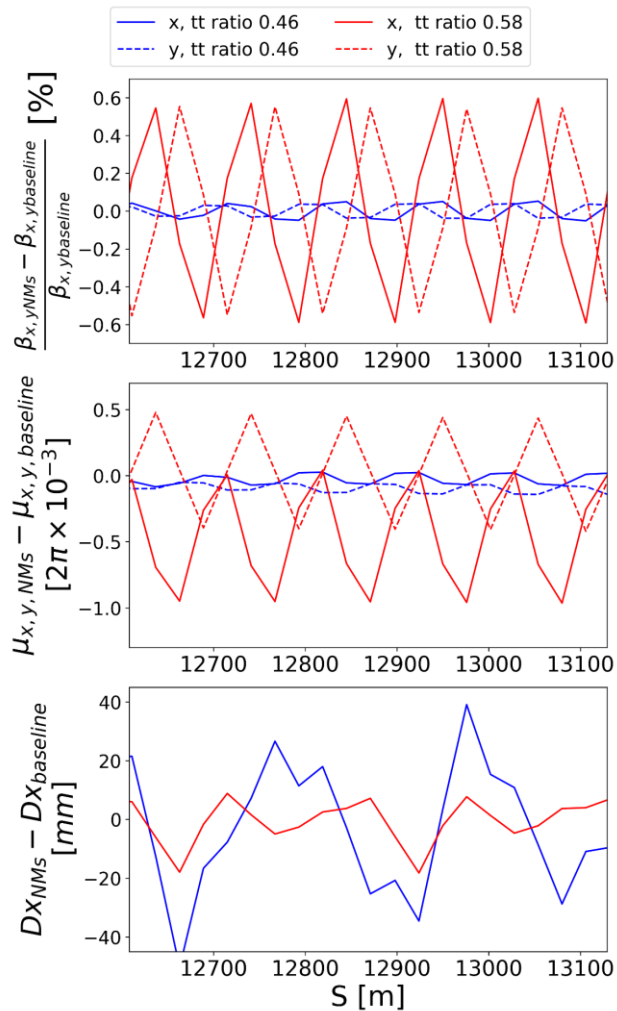
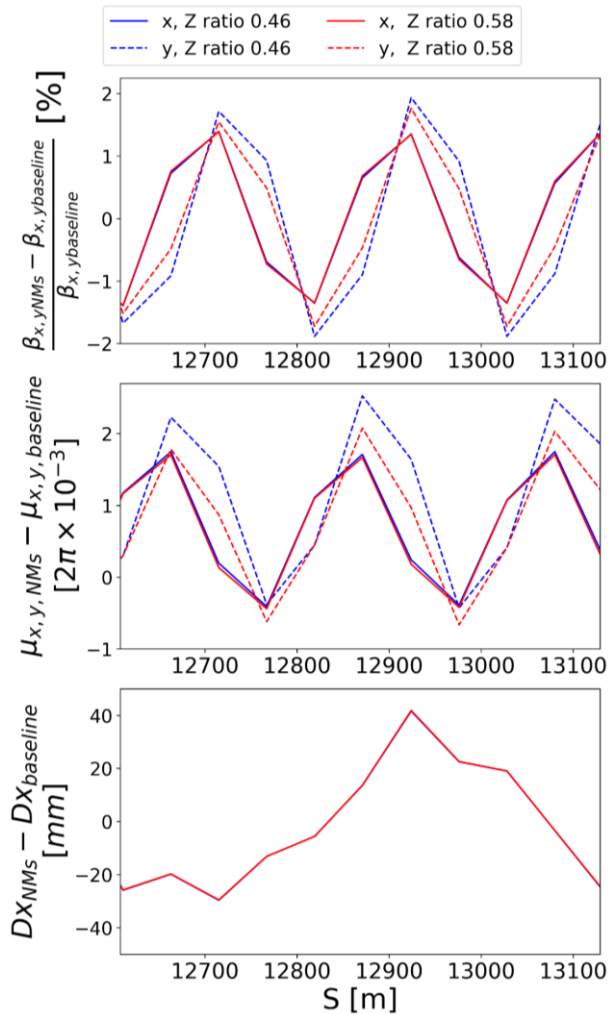

LCC lattice with NMs

Parameter	Z GHC	Z LCC	Z LCC NMs
Emittance [nm]	0.705	0.687	0.685
U0 [Mev/turn]	39.11	34.50 -11.78%	32.12 -17.87%
I2 [E-4]	6.4	5.6	5.2
I4 [E-10]	-2.5	204	216474
DPNs	1 1 2	1 1 2	0.931 0.999 2.06