



FUTURE  
CIRCULAR  
COLLIDER



# ALLEGRO

## A Full Detector Concept For FCC-ee

Martin Aleksa (CERN), Nicolas Morange (IJCLab), Marc-Andre Pleier (BNL)

- What is ALLEGRO – Some History
- The ALLEGRO Full Detector Concept Expression of Interest
- FCC SW Implementation
- Next Steps

# What is ALLEGRO?

- **Noble-liquid calorimeter for future experiments**
  - In 2015 started to think about a noble-liquid ECAL for FCC-hh
  - Became part of the FCC-hh reference detector → CDR in 2019, input to the last Update of the European Strategy (ESU)
  - [CDR](#), FCC-hh calorimeter ([arxiv:1912.09962](#)), FCC-hh reference detector: [CERN Yellow Report](#)
- **After 2020 ESU focus shifted to FCC-ee**
  - We adapted noble-liquid ECAL to work in a lepton collider experiment, performance studies showed that it is very competitive compared to other proposals (Si/W, dual read-out calorimetry) - (see [arxiv:2109.00391](#))
  - Noble-liquid calorimetry became work-package inside [CERN EP R&D](#) and later part of DRD6 as WP2 ([link](#))
- **In 2022 proposed a detector concept based on noble-liquid ECAL**
  - Implemented a version into FCC SW which consisted of a noble-liquid ECAL and some “reasonable” choices for the other sub-detectors. Different choices can easily be tried due to the modularity of the FCC SW. Close collaboration with Sci/Fe HCAL (TileCal) from FCC-hh days
  - Presented detector concept during [FCC Weeks](#), FCC PED Workshops and conferences → triggered interest
  - In 2023 survey to find a name → **ALLEGRO** (A Lepton Lepton collider Experiment with Granular Read-Out) was born
- **Current situation**
  - **Strong noble-liquid ECAL team collaborating within DRD6 WP2** ([link](#))
  - **Call for Expressions of Interest (Eoi) for Full Detector Concepts** issued by FCC Physics, Experiments and Detector (PED) pillar of the Feasibility Study
  - **ALLEGRO** organised kick-off meeting → strong interests from many institutes to work on ALLEGRO full-detector concept.

# Introduction – EoI

## Call for Expressions of Interest (EoI) for Full Detector Concepts issued by FCC Physics, Experiments and Detector (PED) pillar of the Feasibility Study:

- *Encourage the federation of international efforts focussing on full detector concepts, to establish the link between the FCC physics performance requirements and the technological capabilities of the sub-detectors to be developed;*
- *To guide the R&D on sub-detectors and to give feedback on the full-detector performance impact of technological choices*
- Effort of concept groups should primarily focus on:
  - *A consistent simulation model with full simulation in all sub-systems, and the support of high-level reconstruction tools for full-event properties*
  - *An overall engineering model informing the simulations, simplified, but with realistic material budget and dead spaces*
- Efforts should be *well connected to the developments of sub-detector systems and to technological R&D pursued in the framework of the CERN-anchored DRD collaborations*

### Call for Expressions of Interest for the Development of Detector Concepts for the FCC

The Physics, Experiments and Detectors (PED) Pillar of the Future Circular Collider (FCC) Study invites Expressions of Interest (EoIs) by groups of institutes to pursue the development, or further development, of an integrated conceptual detector design for FCC experiments. EoIs for the development of sub-detector designs are being invited in a separate call.

With this, we encourage the federation of international efforts focussing on full detector concepts, to establish the link between the FCC physics performance requirements and the technological capabilities of the sub-detectors to be developed; to guide the R&D on sub-detectors and to give feedback on the full-detector performance impact of technological choices.

In this phase of the FCC project, the work of concept groups should primarily focus on

- A consistent simulation model with full simulation in all sub-systems, and the support of high-level reconstruction tools for full-event properties like di-jet masses or flavour tagging, to evaluate the full-event performance of the detector as a whole
- An overall engineering model informing the simulations, simplified, but with realistic material budget and dead spaces,
  - to guide the optimisation of the global detector parameters and structures
  - to support the development of the machine detector interface (MDI)
  - to provide boundary conditions for sub-detector integration

These concepts should be well connected to the developments of sub-detector systems and to technological R&D pursued in the framework of the CERN-anchored DRD collaborations, and complement these with studies at the full-detector level.

Simulation and reconstruction software should be integrated into the Key4HEP system, provide an interface to the sub-detector developments and an environment for studying their integration, and enable full-simulation-based physics studies.

The forming of (proto-) collaborations will start at a later stage, while presently the combination of different sub-detector technologies inside a given concept should remain open where technically reasonable and supported by the common software framework.

We welcome EoIs for work both on already existing detector concepts as well as new concepts, which are not variants of existing ones; in that case we rather encourage to intensify collaboration.

EoIs should be compact documents (3-6 pages) including

- The scope of planned activities over the next 3-5 years, as well as the partner institutes and their expertise, and the names of one or two contact persons.
- The connection with technological activities in the DRD framework
- References to relevant more detailed documentation of the technologies

# First ALLEGRO Detector Concept Meeting

- **Kick-off meeting** on Nov. 22, 2024
  - <https://indico.cern.ch/event/1475630/>
- **Big interest** from the community
- Receiving **Expressions of Interest (EoI)** to work on different aspects/sub-detectors from **47 institutes**
- Compiled an **Expression of Interest** for the European Strategy Update
  - <https://indico.cern.ch/event/1439855/contributions/6461614/>
  - **170 authors** from **47 institutes**

## Expression of Interest for the ALLEGRO Full-Detector Concept for FCC-ee

---

M. Aleksa<sup>1</sup>,<sup>1</sup> N. Morange,<sup>2</sup> M.-A. Pleier,<sup>3</sup> G. Aad,<sup>4</sup> T.K. Aarrestad,<sup>5</sup> R. Aleksan,<sup>6</sup> M. Alvigi,<sup>7,8</sup> T. Andeen,<sup>9</sup> J. Andrea,<sup>10</sup> F. Anulli,<sup>11,12</sup> F. Aretio-Zárate,<sup>1</sup> O. Arnaez,<sup>13</sup> H. Arnold,<sup>14</sup> N.A. Asbah,<sup>1</sup> M. Backhaus,<sup>5</sup> M. Barbero,<sup>4</sup> T. Barillari,<sup>15</sup> J. Baudot,<sup>10</sup> H.P. Beck,<sup>16</sup> G. Bernardi,<sup>17</sup> A. Besson,<sup>10</sup> M. Biglietti,<sup>18</sup> F. Blanc,<sup>19</sup> M. Bomben,<sup>17</sup> M. Boscolo,<sup>20</sup> G. Boudoul,<sup>21</sup> S. Bressler,<sup>22</sup> G. Calderini,<sup>23</sup> L. Caminada,<sup>24,25</sup> F. Canelli,<sup>24</sup> G. Charles,<sup>2</sup> A. Chaudhuri,<sup>26</sup> H. Chen,<sup>3</sup> R. Chiche,<sup>2</sup> S. Cieri,<sup>15</sup> D. Contardo,<sup>21</sup> M. Corradi,<sup>11,12</sup> T. Dai,<sup>27</sup> M. Dam,<sup>28</sup> R. De Asmundis,<sup>8</sup> A. Deiana,<sup>29</sup> M. Della Pietra,<sup>7,8</sup> M. Delmastro,<sup>13</sup> G. Deptuch,<sup>3</sup> K. Dewyspelaere,<sup>17</sup> C. Di Donato,<sup>8</sup> B. Di Micco,<sup>18</sup> R. Di Nardo,<sup>18</sup> F. Djama,<sup>4</sup> M. Donega,<sup>5</sup> A. Durglishvili,<sup>30</sup> G. Eigen,<sup>31</sup> Z. El Bitar,<sup>10</sup> W. Erdmann,<sup>25</sup> F. Fallavollita,<sup>15</sup> J. Faltova,<sup>32</sup> L. Felgion,<sup>4</sup> L. Fiorini,<sup>33</sup> D. Fournier,<sup>2</sup> B. François,<sup>1</sup> J. Fried,<sup>3</sup> N. Gallice,<sup>3</sup> S. Gao,<sup>3</sup> C. Gargiulo,<sup>1</sup> J. Ge,<sup>27</sup> V. Gkoukousis,<sup>24</sup> T. Golling,<sup>34</sup> L. Guan,<sup>27</sup> Y. Guo,<sup>27</sup> G. Haefeli,<sup>19</sup> M. Haviernik,<sup>32</sup> C. Herwig,<sup>27</sup> M. Himmelsbach,<sup>9</sup> Z. Huang,<sup>2</sup> G. Iakovidis,<sup>3</sup> P. Iengo,<sup>7,8</sup> A. Ilg,<sup>24</sup> M. Iodice,<sup>18</sup> M. Kado,<sup>15</sup> P. Karst,<sup>4</sup> B. Kilminster,<sup>24</sup> A. Kiryunin,<sup>15</sup> S. Kluth,<sup>15</sup> P. Kontaxakis,<sup>34</sup> M. Koppitz,<sup>1,35</sup> O. Kortner,<sup>15</sup> S. Kortner,<sup>15</sup> B. Korzh,<sup>34</sup> A. Koulouris,<sup>1</sup> H. Kroha,<sup>15</sup> C. Lange,<sup>25</sup> S. Leontsinis,<sup>24</sup> T. Li,<sup>17</sup> C. Li,<sup>27</sup> T. Loeliger,<sup>36</sup> C. Luci,<sup>11,12</sup> A. Macchiolo,<sup>24</sup> A. Maloizel,<sup>17</sup> R. Marchevski,<sup>19</sup> G. Marchiori,<sup>17</sup> J. Maurer,<sup>37</sup> S. Menke,<sup>15</sup> M. Mentink,<sup>1</sup> O. Mezhenska,<sup>38</sup> M. Mlynarikova,<sup>1</sup> S. Mobius,<sup>16</sup> S. Molina,<sup>1</sup> E. Monnier,<sup>4</sup> P. Mukim,<sup>3</sup> K. Nelson,<sup>27</sup> N. Nikiforou,<sup>1</sup> R. Nisius,<sup>15</sup> P. Onyisi,<sup>9</sup> P. Owen,<sup>24</sup> F. Palla,<sup>39,1</sup> T.H. Park,<sup>15</sup> J. Parsons,<sup>40</sup> R. Pedro,<sup>41</sup> J. Pekkanen,<sup>1</sup> E. Petit,<sup>4</sup> F. Petrucci,<sup>18</sup> I. Polak,<sup>42</sup> G. Popeneciu,<sup>43</sup> G. Proto,<sup>15</sup> C. Pruiti,<sup>1,11</sup> J. Qian,<sup>27</sup> V. Radeka,<sup>3</sup> B. Ravina,<sup>1</sup> S. Rescia,<sup>3</sup> R. Richter,<sup>15</sup> S. Rosati,<sup>12</sup> J. Rutherford,<sup>44</sup> E. Salzer,<sup>27</sup> P. Schacht,<sup>15</sup> S. Schramm,<sup>34</sup> T. Schwarz,<sup>27</sup> P. Schwemling,<sup>6</sup> G. Sekhniaidze,<sup>8</sup> S. Senyukov,<sup>10</sup> N. Serra,<sup>24</sup> A. Sfyrla,<sup>34</sup> L. Shchutska,<sup>19</sup> R. Simoniello,<sup>1</sup> S. Snyder,<sup>3</sup> O. Solovyanov,<sup>45</sup> F. Sopkova,<sup>32</sup> P. Strizeneec,<sup>38</sup> G. Suliman,<sup>46</sup> C. Suslu,<sup>27</sup> G. Tarna,<sup>37</sup> A. Tricoli,<sup>3</sup> V. Tudorache,<sup>37</sup> A. Upegui,<sup>47</sup> R. Vari,<sup>11,12</sup> E. Varnes,<sup>44</sup> S. Veneziano,<sup>11,12</sup> A. Verbyskiy,<sup>15</sup> E. Voevodina,<sup>15</sup> R. Wallny,<sup>5</sup> C. Wang,<sup>9</sup> C. Weaverdyck,<sup>27</sup> M. Weber,<sup>16</sup> T. Wengler,<sup>1</sup> H. Wilkens,<sup>1</sup> Z. Wu,<sup>13</sup> B. Yu,<sup>3</sup> C. Zhang,<sup>3</sup> M. Zhao,<sup>3</sup> B. Zhou<sup>27</sup> and J. Zhu<sup>27</sup>

# EoI for Full Detector Concept

Sub-Detector	Institutes
Vertex Det. and MDI Region	ETH Zurich (CH), Univ. of Zurich (CH), PSI (CH), BNL (US), INFN Pisa (IT), INFN Frascati (IT), IPHC (FR), CPPM (FR), LPNHE (FR), APC (FR), IP2I (FR)
Tracker	Univ. of Michigan (US), MPP Munich (DE), BNL (US), UT Austin (US), IJCLab (FR), EPFL (CH)
Timing Layer	Univ. of Zurich (CH), PSI (CH), BNL (US), CEA-Irfu (FR), IP2I Lyon (FR)
Electromagnetic Calorimeter	CERN, APC (FR), IJCLab (FR), CPPM (FR), OMEGA (FR), LAPP (FR), MPP Munich (DE), TU Dresden (DE), BNL (US), Brown Univ. (US), NYU (US), Columbia Univ. (US), SMU (US), Univ. of Arizona (US), UT Austin (US), Stony Brook (US), Charles Univ. (CZ), IFIN-HH and UPB (RO), IEP SAS Kosice (SK)
Solenoid and Cryostat	CERN
Hadronic Calorimeter	ITIM Cluj Napoca (RO), LIP (PT), IFIC Valencia (ES), Bergen (NO), FZU (CZ), Charles Uni (CZ), Tbilisi (GE), CERN
Muon System	MPP Munich (DE), Weizmann Institute (IL), Univ. of Napoli (IT), Rome 1 (IT), Rome 3 (IT), Univ. of Michigan (US)
Luminosity Calorimeter	Univ. of Geneva (CH), Univ. of Zurich (CH), Univ. of Copenhagen (DK)
Read-Out and Trigger	CERN, Univ. of Geneva (CH), HEPIA (CH), Univ. of Zurich (CH), ZHAW (CH), MPP Munich (DE)
Software and Simulation	CERN, APC (FR), IJCLab (FR), LAPP (FR), UT Austin (US), B.K.C College (IN)

- Most of these groups have also submitted EoI's for sub-detectors
- Details in <https://indico.cern.ch/event/1529896/>

Sub-Detector	EoI IDs
Vertex Det. and MDI Region	ID0019, ID0027, ID0036, ID0047, ID0069, ID0088, ID0105
Tracker	ID0015, ID0024, ID0043, ID0061, ID0080, ID0085, ID0098, ID0099
Timing Layer	ID0080, ID0096, ID0098, ID0099
Electromagnetic Calorimeter	ID0023, ID0031, ID0064, ID0067, ID0082
Solenoid and Cryostat	
Hadronic Calorimeter	ID0086
Muon System	ID0011, ID0016, ID0037, ID0049, ID0060, ID0069, ID0078, ID0084
Luminosity Calorimeter	ID0104
Read-Out and Trigger	ID0017, ID0092, ID0103

# DRD6 WP2 Organisation – ALLEGRO ECAL

## WP2 reminder: organisational structure

See [talk by Z. Wu](#) on Tuesday

### • **Currently** contributing institutes

- APC (Paris, France)
- BNL (Brookhaven, USA)
- Brown University (Providence, USA)
- CERN
- CPPM (Marseille, France)
- CUNI (Prague, Czech Republic)
- IFIN-HH + UNSTPB (Bucharest, Romania)
- IJCLab (Orsay, France)
- LAPP (Annecy, France)
- MPI Munich (Germany)
- NYU (NY, USA)
- Omega (Palaiseau, France)
- Southern Methodist University (Dallas, USA)
- Stony Brook University (USA)
- TU Dresden (Germany)
- IEP SAS Kosice (Slovakia)
- University of Arizona (USA)
- University of Columbia (NY, USA)
- UT Austin (USA)

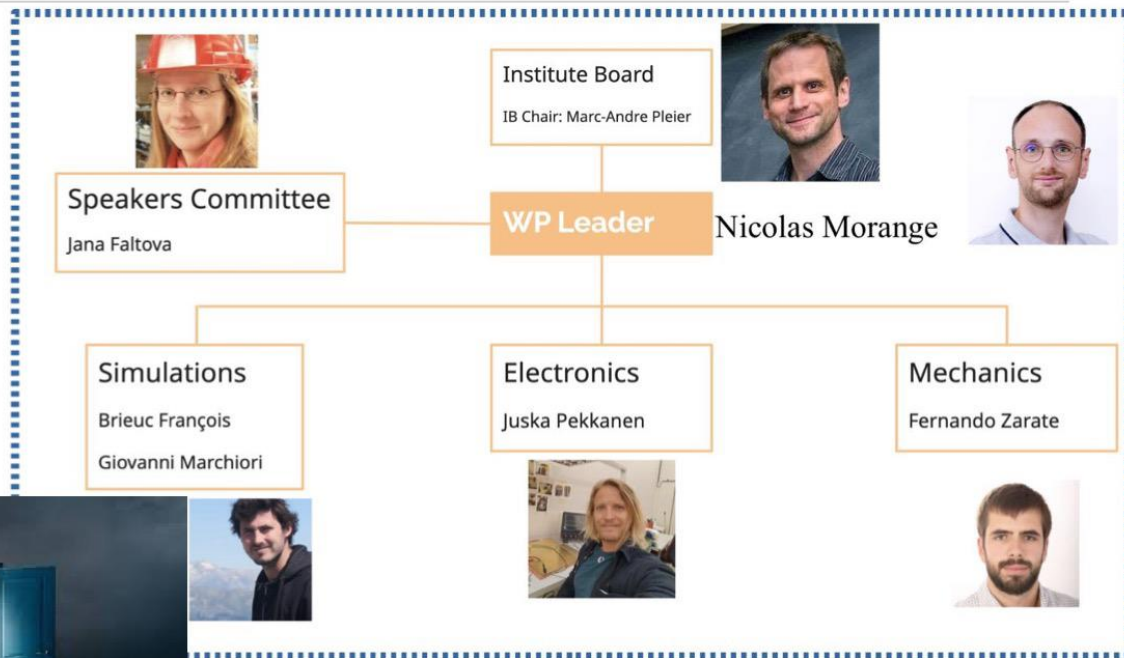

**19 institutes in  
8 countries**



Web Page: <https://allegro.web.cern.ch>

**ALLEGRO ECAL (now DRD6 WP2) Meetings:**

<https://indico.cern.ch/category/18309/> & <https://indico.cern.ch/category/8922/>

# ALLEGRO Detector Concept



## ALLEGRO

A Lepton Lepton collider Experiment with Granular Read-Out

## Vertex Detector

## Tracking

## Silicon Wrapper + ToF

## High Granularity ECAL

- Excellent resolution, linearity, stability
- Optimised for particle flow
- Noble-liquid as active material

**Solenoid  $B=2T$**  (study option to go  $B>2T$  for c.o.m. energies  $> Z$ -pole), sharing cryostat with ECAL, between ECAL and HCAL

- Light solenoid coil  $\approx 0.76 X_0$  (see back-up)
- Low-material cryostat  $< 0.1 X_0$  (see back-up)

## High Granularity HCAL / Iron Yoke

## Muon Tagger

First introduced at [FCC Week 2022](#) in Paris ([link to talk](#))

# ALLEGRO Detector Concept

From the beginning many different ideas/options → very open for new ideas  
Envelopes need to be optimised/adapted to chosen technologies  
But had to start with one version which was implemented into FCC SW



# FCC SW – ALLEGRO Simulation

- **What do we currently have in the ALLEGRO simulation?**
- **Tracking system taken from IDEA 'as is'**
  - Vertex detector with curved sensors (can be made straight)
  - Drift chamber z-extent un-changed (to be optimized)
  - Silicon Wrapper similar to the vertex detector but with planar sensors
- **Flexible Noble Liquid ECAL barrel with inclined absorbers**
  - Baseline: straight Pb+Steel absorber, growing sensitive gap
- **Turbine geometry Noble Liquid ECAL endcaps**
  - First version available
- **TileCal HCAL tuned to FCC-ee (barrel and endcaps)**
- **Muon Tagger as sensitive cylinder/disks**
  - Mainly a place holder

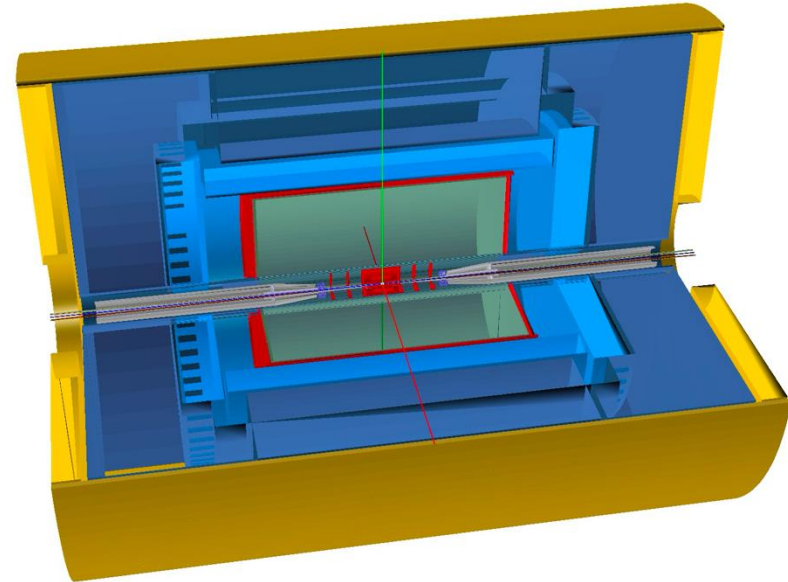

Courtesy Brieuc Francois

# ALLEGRO Simulation & Reconstruction

- **ALLEGRO simulation is fully integrated in the Key4hep framework**
  - As for the other FCC detectors (a must to leverage synergies)
  - **Very modular approach** → once your sub-detector is implemented events can be simulated with other ALLEGRO sub-detectors → easy to compare physics performance
- **What is currently available for the ALLEGRO reconstruction**
  - Gaussian smearing based vertex detector, drift chamber and silicon wrapper digitization
    - Parametrized cluster counting available for the drift chamber
  - Generator particle based tracking
  - Fairly detailed calorimeter digitization (calibration, noise, cross-talk)
  - Several calorimeter clusterings: sliding window, topological clustering, CLUE
    - MVA based calibration and theta correction available
  - MVA based  $\pi^0$ /photon separation algorithm
  - Calo only jet clustering
  - Particle-flow object (PFO) reconstruction with PandoraPFAis under development

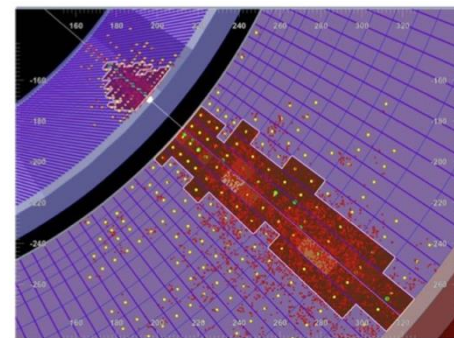

*clustering in ECAL (and HCAL) barrels  
now working on endcap clustering*

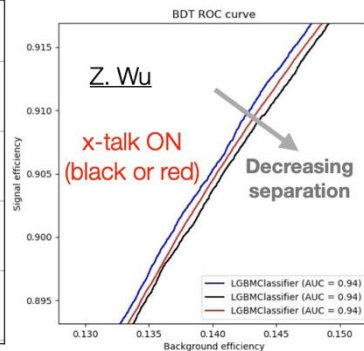
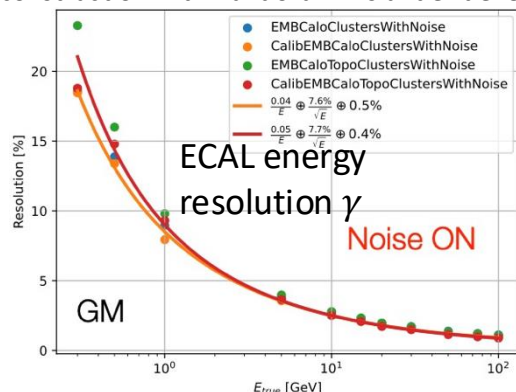
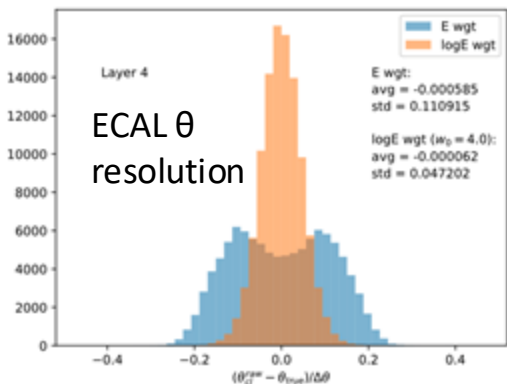

*photon/ $\pi^0$  discrimination*

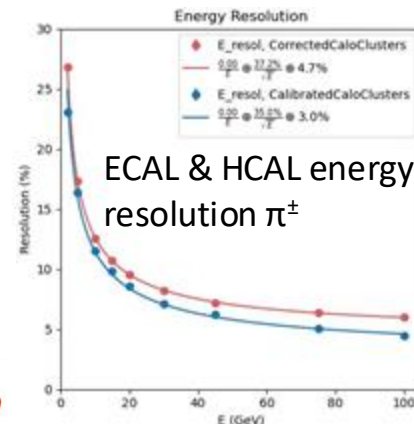

**ECAL & HCAL energy resolution  $\pi^\pm$**

# Work Ahead – Some Points of Attention

General: Develop a detector that match the performance set by physics benchmarks

- **Vertex Detector & MDI Region:**
  - Sensor technology exists (MAPS, EP R&D WP1.2, DRD3), but light weight support structures, low-material power and cooling infrastructure needs to be developed
  - Continue & strengthen engineering effort on MDI region, support of vertex detectors and LumiCal – develop MDI for all detector concepts
- **Tracking:**
  - Different proposals: Scintillating Fibre tracker, Si tracker (DRD3), gaseous tracker (DRD1): drift chamber, straw tracker
  - Minimize material, start engineering of support structures, services, power, cooling...
- **Particle ID:**
  - Interesting ideas to complement e.g. Si tracker with ARC
  - Low GWP gases/gels for Cherenkov detectors
  - ToF detector (e.g. LGADs)
- **Calorimetry:**
  - Continue building prototypes of all proposed calorimeters, testbeams (DRD6)
  - Define needed granularity, performance optimization
  - Engineering
- **Muon Tagger / Muon System:**
  - Large area gas detectors, technology exists
  - Need to define what is needed for optimal physics reach
  - Low GWP gases for gas detectors (e.g. RPC)
- **Software:**
  - Detector concepts existing in FCC SW, modular approach, can easily plug in new detectors, new ideas
  - Particle flow starting to work, but needs tuning
- **Trigger and DAQ:**
  - Do we need a trigger or can we read out everything (additional power & cooling → more material)
  - Closely linked to studies of occupancies caused by background (Bhabha scattering,  $\gamma\gamma$  hadrons, Beamstrahlung)
- **Magnets:**
  - Effort to re-establish availability of a reinforced aluminum-stabilized Nb-Ti conductors needed for FCC-ee, as well as to investigate novel HTS-based conductor technology and its implications (EP R&D WP8)
- **Cryostats:**
  - Further development of low-material carbon-composite cryostats as well as carbon fibre and aluminum honeycomb (EP R&D WP4)
  - Tightness of flanges to stainless steel feed-throughs
  - Tests of prototypes

# Next Steps – FCC Detector Concepts Group

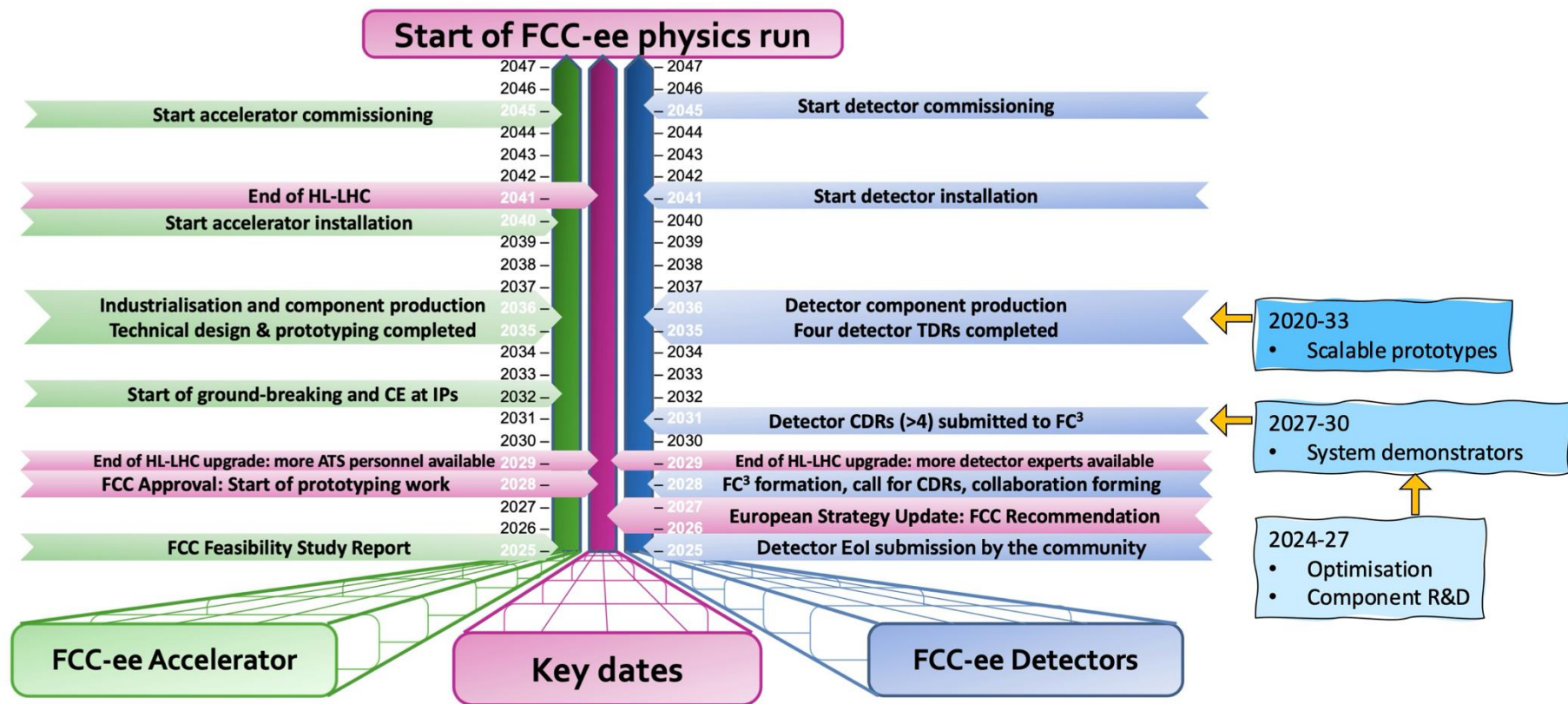

M. Dam, FCC Week 2025

# Next Steps – ALLEGRO

- Prepared an EoI for the ALLEGRO full-detector concept for the ongoing European Strategy Update (ESU) in response to the EoI call for full-detector concepts
- We aim to propose ALLEGRO as a high-performance general-purpose detector concept for FCC-ee, that will fulfil all the requirements of its ambitious physics program. While the concept is centred around a noble-liquid based ECAL, the technology choices concerning all other sub-detectors are fully open

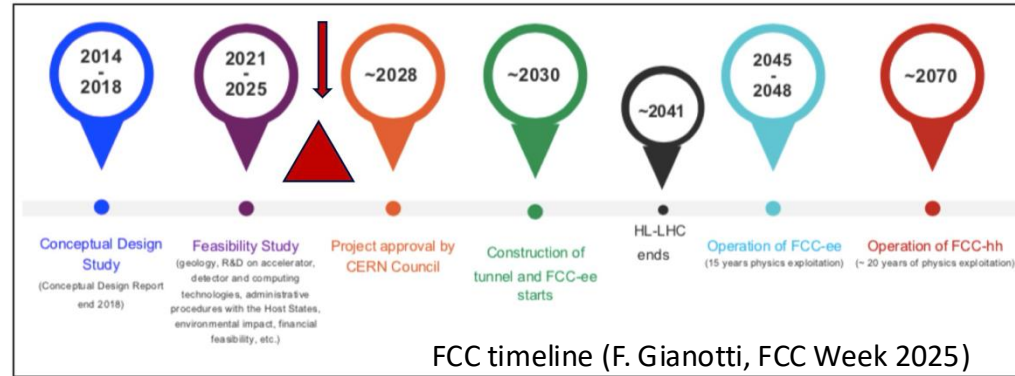

- At this stage there is no formation of any collaboration planned yet, no commitment by any of the groups, we would just like to start listing interested institutes and groups who are planning to possibly contribute in one way or another to the ALLEGRO detector concept. We are very open to any contributions and proposals for sub-detectors provided they are thought to be suited to comply with the physics benchmarks of FCC-ee
- In the coming years there could be several options for the different ALLEGRO sub-detector systems. We encourage of course to work together and possibly converge. A down-selection to baseline options and the formation of a proto-collaboration we expect once a decision on FCC-ee has been taken and once we enter the CDR and later TDR phase (possibly in the coming 5 years → in line with the timeline proposed in the slide before: ~2028)
- Until then it is important that all sub-detectors get further developed within the DRDs, including system demonstrators and those detectors get fully integrated into the FCC SW to enable us to do ALLEGRO full detector simulations with different sub-detectors

# Next Steps – ALLEGRO

- Will try to find contact persons to channel the momentum from the Eols in below categories
  - **Vertex detector & MDI region & Tracker**
  - **ECAL** (DRD6 WP2)
  - **Solenoid & cryostat**
  - **HCAL**
  - **Muon system**
  - Luminosity calorimeter
  - **Read-out & trigger**

# Status of DRD Collaborations

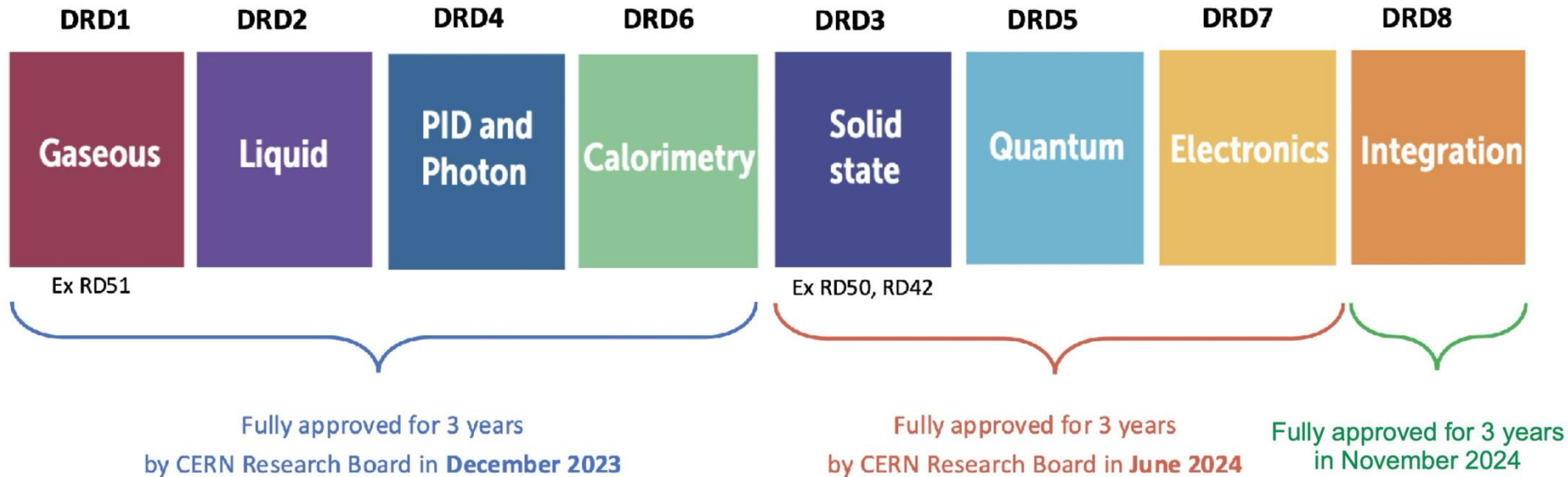

DRD Meetings:  
<https://indico.cern.ch/category/6805/>

M. Dam, FCC Week 2025

# Conclusions

- **ALLEGRO** has been proposed as a **high-performance general-purpose detector concept for FCC-ee** – an **EoI was submitted for the ESU**
- There is a **strong noble-liquid ECAL** team (19 institutes)
- We have **collected interests to work on ALLEGRO** – no commitments at this stage, but interests expressed by 47 institutes, 170 authors
- In the coming years we should **further develop our ideas of detectors within the existing DRDs**, keeping the **physics requirements** in mind, **build prototype detectors** and **implement them into FCC SW** with **realistic performance**
- The **invitation to join ALLEGRO** remains of course **open** – there is plenty of space to contribute!
- We expect a **decision on FCC-ee in 3-5 years** from now. Will then enter the CDR and later TDR phase.
- **→ Working on ALLEGRO is building our future!**
- **Many interesting challenges ahead of us!**
- **Come and join us!**



# Thank You for Your Attention!

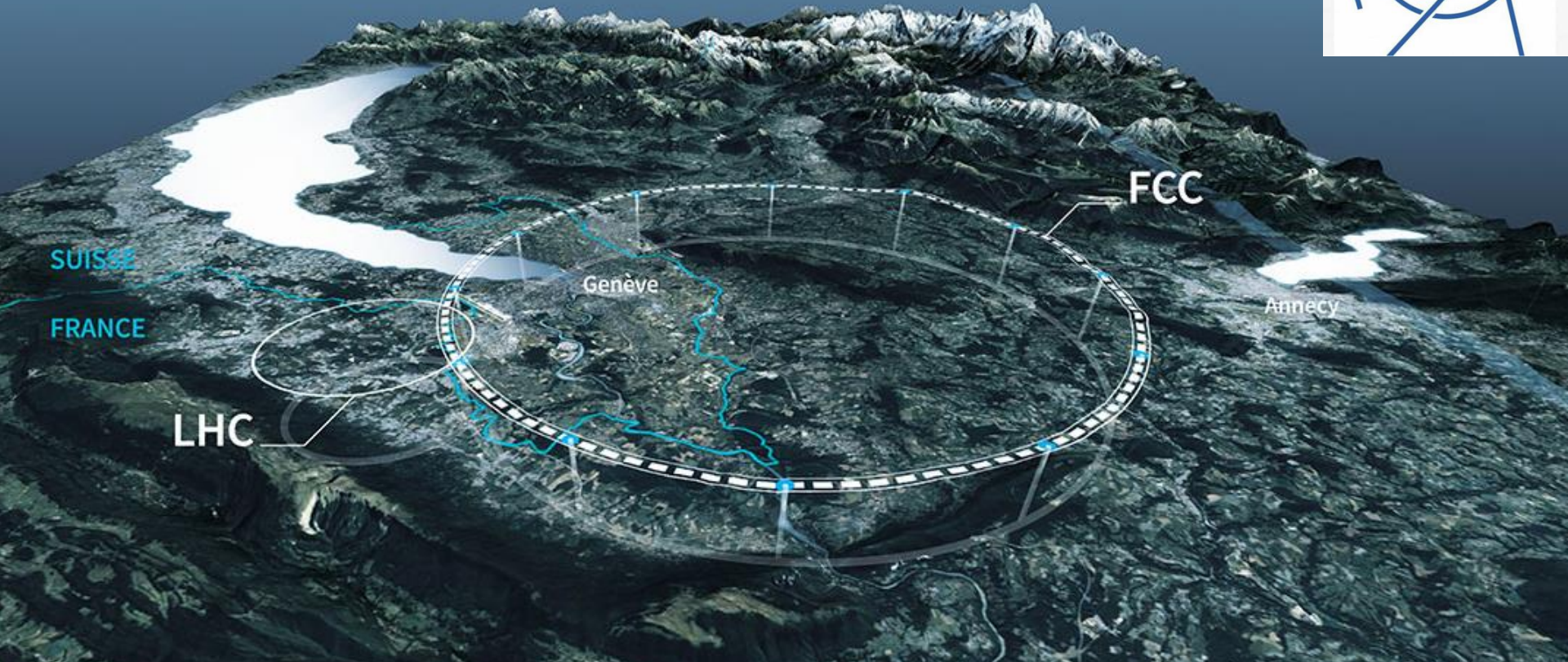

ALLEGRO Detector Concept Future Plans – M. Aleksa, N. Morange, M.A. Pleier



# Back-Up

# Calorimetry

Energy coverage < 300 GeV  $\rightarrow$  22  $X_0$ , 7 $\lambda$

Precise jet angular resolution

**Jet energy:**  $\sigma(E_{\text{jet}})/E_{\text{jet}} \approx 30\% / \sqrt{E} [\text{GeV}]$  ?

$\Rightarrow$  Mass reconstruction from jet pairs

Resolution important for control of (combinatorial) backgrounds in multi-jet final states with  $E_T^{\text{miss}}$

How to achieve jet energy res. of  $\sim$ 3-4% at 50GeV:

- Highly granular calorimeters
- Particle flow reconstruction and possibly in addition techniques to correct non-compensation ( $e/h \neq 1$ ), e.g. dual read-out

- Excellent Jet resolution:  $\approx 30\%/\sqrt{E}$
- ECAL resolution:
  - Higgs physics  $\approx 15\%/\sqrt{E}$
  - But for heavy flavour programme better resolution beneficial:  $\rightarrow 8\%/\sqrt{E} \rightarrow 3\%/\sqrt{E}$
- Fine segmentation for PF algorithm and powerful  $\gamma/\pi^0$  separation and measurement

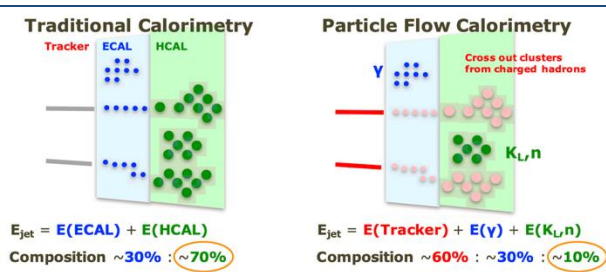

Detector technology (ECAL & HCAL)	E.m. energy res. stochastic term	E.m. energy res. constant term	ECAL & HCAL had. energy resolution (stoch. term for single had.)	ECAL & HCAL had. energy resolution (for 50 GeV jets)	Ultimate hadronic energy res. incl. PFflow (for 50 GeV jets)
Highly granular Si/W based ECAL & Scintillator based HCAL	15 – 17% [12,20]	1% [12,20]	45 – 50% [45,20]	$\approx$ 6% ?	4% [20]
Highly granular Noble liquid based ECAL & Scintillator based HCAL	8 – 10% [24,27,46]	< 1% [24,27,47]	$\approx$ 40% [27,28]	$\approx$ 6% ?	3 – 4% ?
Dual-readout Fibre calorimeter	11% [48]	< 1% [48]	$\approx$ 30% [48]	4 – 5% [49]	3 – 4% ?
Hybrid crystal and Dual-readout calorimeter	3% [30]	< 1% [30]	$\approx$ 26% [30]	5 – 6% [30,50]	3 – 4% [50]

For more information see <https://link.springer.com/article/10.1140/epjp/s13360-021-02034-2>

# FCC Calorimetry

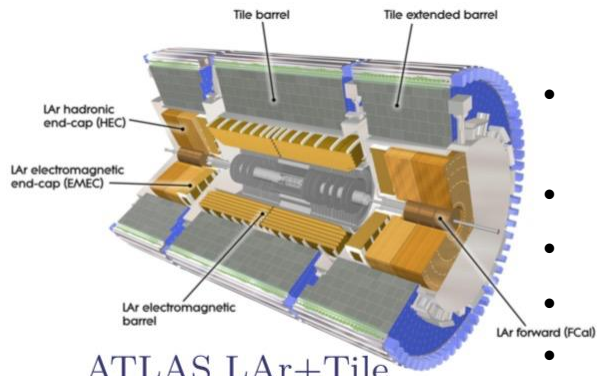

ATLAS LAr+Tile

arXiv:1305.4551

- Good intrinsic energy resolution
- Radiation hardness
- High stability
- Linearity and uniformity
- Easy to calibrate

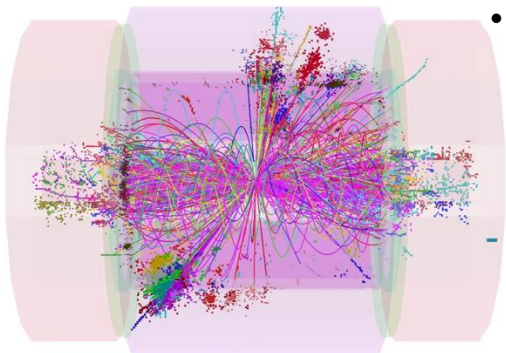

CLIC Detector

- High granularity
  - Pile-up rejection
  - Particle flow
  - 3D/4D/5D imaging

## FCC Calorimetry

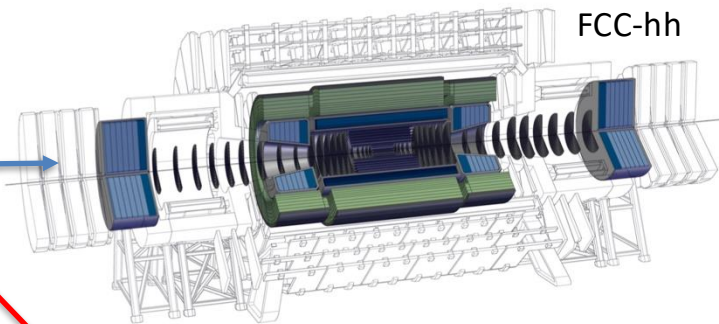

FCC-hh

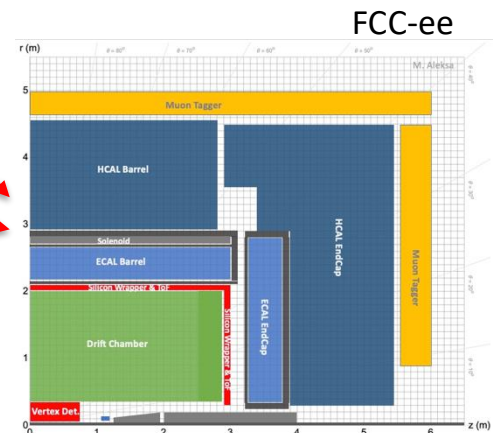

FCC-ee

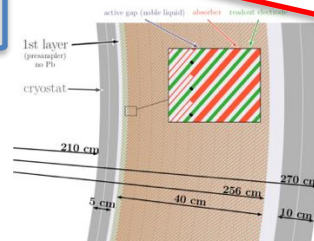

FCC-hh Calorimetry studies have been published at <https://arxiv.org/abs/1912.09962>

# Example – Stability of ATLAS LAr Energy Scale

- **Noble-liquid calorimetry:** High intrinsic stability (see gain and pedestal stability)
  - Pedestal stability  $< 100$  keV (!)
  - Gain stability  $2.6 \times 10^{-4}$
- These parameters are monitored in daily calibration runs  $\rightarrow$  constants are updated when necessary (about once a month)
- $\rightarrow$  Leading to high stability of the energy scale of  $2 \times 10^{-4}$ , monitored by invariant mass  $m_{ee}$  ( $Z \rightarrow ee$  events) and  $E/p$

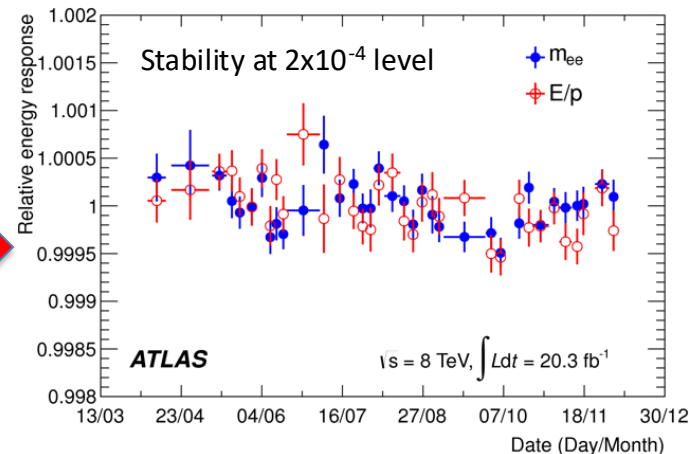
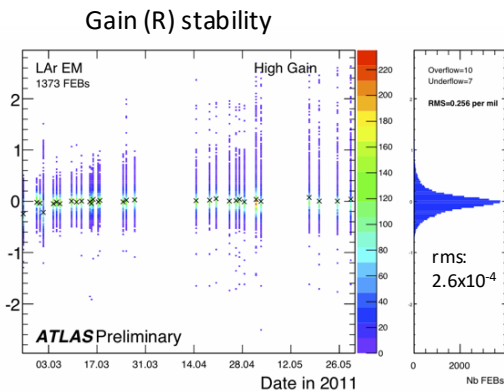
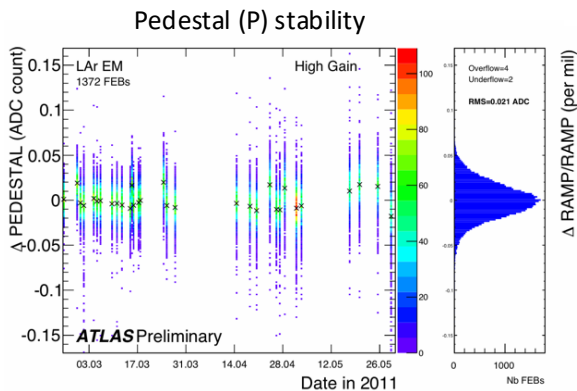

# Granularity – What are the Limits in ATLAS LAr?

- In the ATLAS LAr calorimeter electrodes have 3 layers that are glued together ( $\sim 275\mu\text{m}$  thick)
  - 2 HV layers on the outside
  - 1 signal layer in the middle
- $\rightarrow$  All cells have to be connected with fine signal traces (2-3mm) to the edges of the electrodes
  - Front layer read at inner radius
  - Middle and back layer read at outer radius
- $\rightarrow$  limits lateral and longitudinal granularity
- $\rightarrow$  maximum 3 long. layers

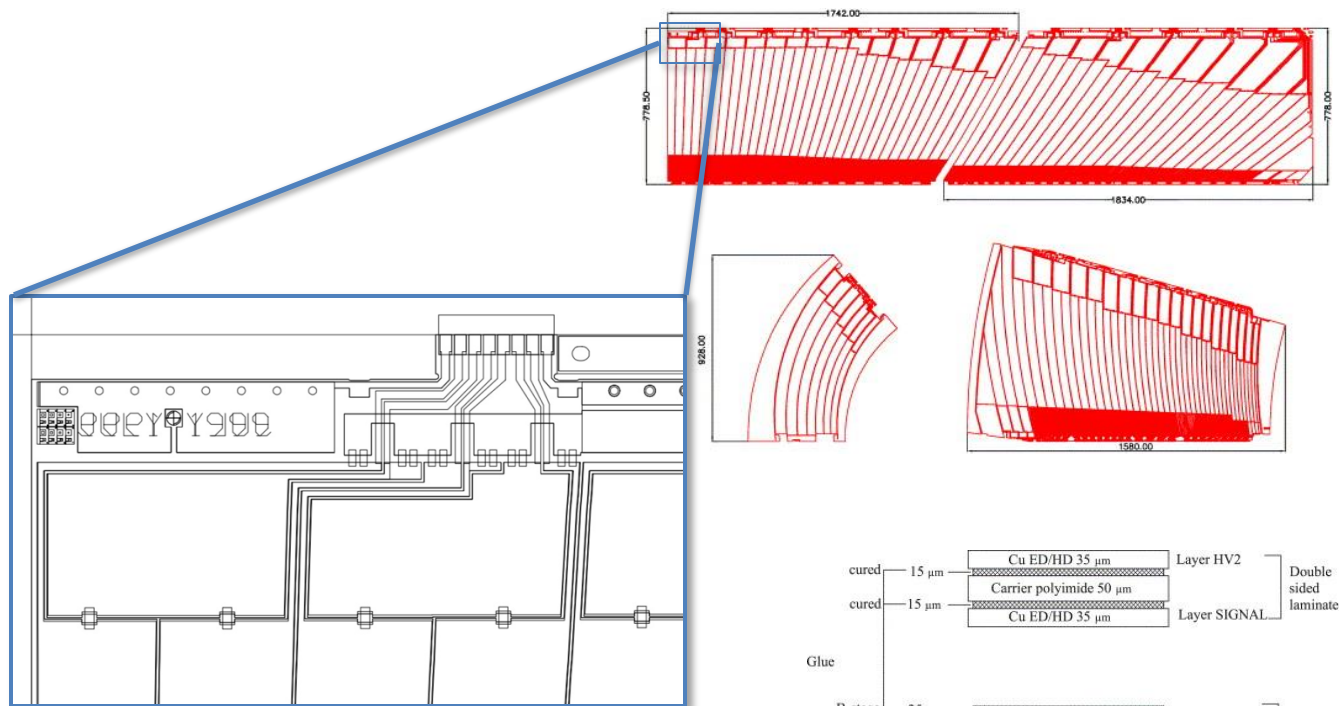
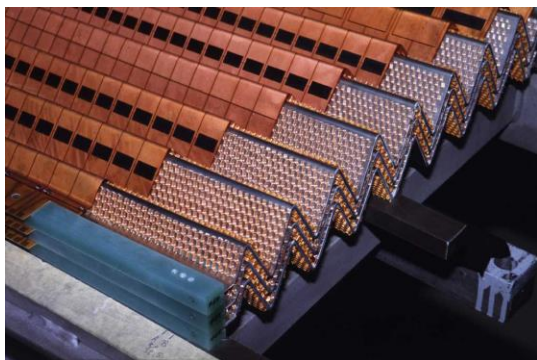

$\rightarrow$   $O(200k)$  read-out cells – particle flow reconstruction possible, but not optimal

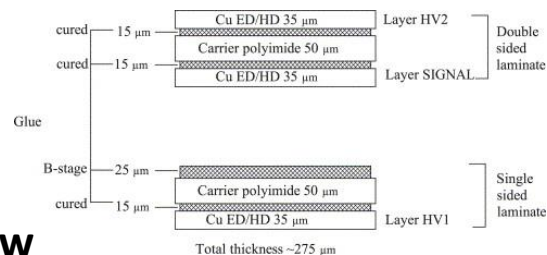

# Noble-Liquid Calo: How to Achieve High Granularity?

## Realize electrodes as multi-layer PCBs

( $H=1.2\text{mm}$  thick), 5 to 7 layers

- HV and read-out
- Signal traces (width  $w_t$ ) in dedicated signal layer connected with vias to the signal pads
- Traces shielded by ground-shields (width  $w_s$ , dist.  $h_s$ ) forming  $50\Omega - 80\Omega$  transmission lines
  - Optimizing between 0, 1 or 2 shield layers
- $\rightarrow$  capacitance between shields and signal pads  $C_s$  will add to the detector capacitance via the gap  $C_d$
- $\rightarrow C_{cell} = C_s + C_d \approx 25 - 300\text{pF}$
- The higher the granularity the more shields are necessary  $\rightarrow C_s$  increases,  $C_d$  decreases (smaller cells)

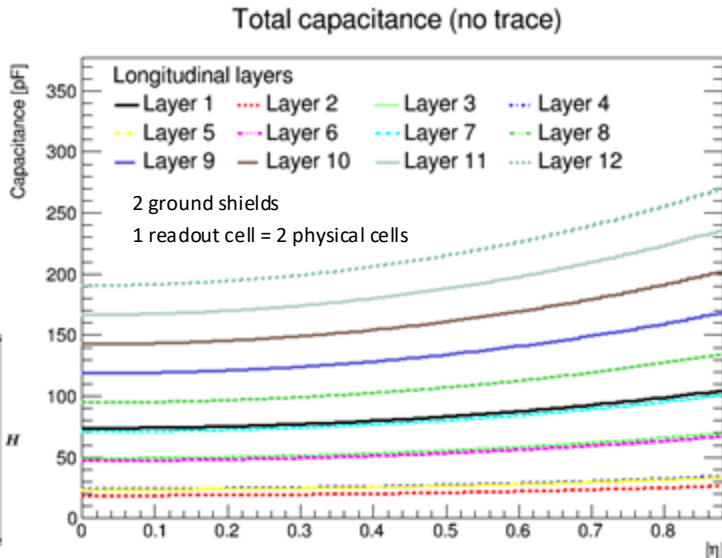
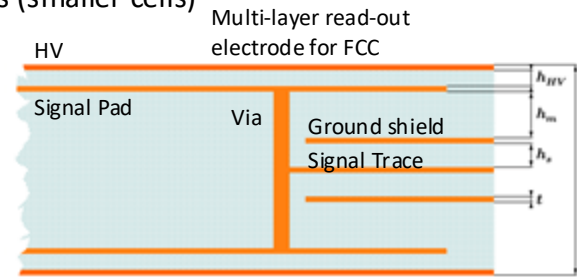
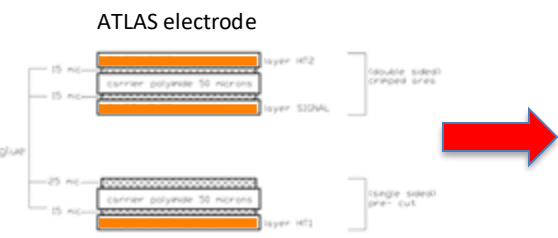
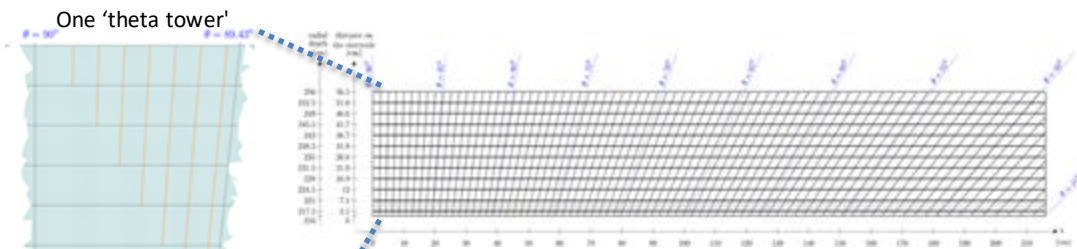

In principle any granularity realisable  $\rightarrow$  cost in cross-talk and noise  $\rightarrow$  careful optimization!

# High Granularity Noble-Liquid Calorimeter

## Baseline design

- 1536 straight inclined ( $50.4^\circ$ ) 1.8mm Pb absorber plates
- $R_i=216\text{cm}$ ,  $R_o=256\text{cm}$  (small adjustments possible/probable)
- Multi-layer PCBs as readout electrodes
- 1.2 – 2.4mm LAr gaps
- 40cm deep ( $\approx 22 X_0$ )
- Segmentation:
  - $\Delta\theta = 10$  (2.5) mrad for regular (1<sup>st</sup> comp. strip) cells,
  - $\Delta\phi = 8$  mrad
  - cell size in strips: 5.4mm x 17.8mm x 30mm
- 11 longitudinal compartments
- Implemented in FCC-SW Fullsim
- Exact radius and lateral and longitudinal segmentation subject to further optimization!

## Possible Options

- LKr or LAr, W or Pb absorbers,
- Absorbers with growing thickness
- Granularity optimization
- Al or carbon fibre cryostat
- Warm or cold electronics

