



FCCIS – The Future Circular Collider Innovation Study. This INFRADEV Research and Innovation Action project receives funding from the European Union’s H2020 Framework Programme under grant agreement no. 951754.

# MDI OVERVIEW AND IR MOCKUP STATUS

Manuela Boscolo (INFN-LNF)

on behalf of the MDI group

FCC WEEK Conference 2025

19 - 23 May 2025

Vienna, Austria



# Outline

- Introduction
- Interaction region layout
- Backgrounds studies
- IR mockup status
- Outlook

And many other topics not covered here

# FCC WEEK 2025 – MDI sessions

2 sessions

Thu 22 8H30

Thu 22 10H30

90 min. each

MDI-1

MDI-2

Version: 0.16		Date: 07.05.2025																			
Day	Monday	Tuesday					Wednesday					Thursday					Friday	Day			
Time	Plenary	Parallel 1	Parallel 2	Parallel 3	Parallel 4	Board Room	Plenary	Parallel 1	Parallel 2	Parallel 3	Parallel 4	Board Room	Plenary	Parallel 1	Parallel 2	Parallel 3	Parallel 4	Board Room	Plenary	Time	
Room	Zeremoniensaal (472 p.)	Geheime Ratsstube (146 p.)	Rittersaal (158 p.)	Trabantenstube (96 p.)	Künstlerzimmer (77 p.)	Radetzky Ap.1 (30 p.)	Zeremoniensaal (500 p.)	Geheime Ratsstube (146 p.)	Rittersaal (158 p.)	Trabantenstube (96 p.)	Künstlerzimmer (77 p.)	Radetzky Ap.1 (30 p.)	Geheime Ratsstube (146 p.)	Rittersaal (158 p.)	Trabantenstube (96 p.)	Künstlerzimmer (77 p.)	Radetzky Ap.1 (30 p.)	Zeremoniensaal (472 p.)	Room		
08:00-08:30	Welcome coffee	Welcome coffee					Welcome coffee					Welcome coffee					Welcome coffee				
08:30-09:00	1. Welcome remarks 2. FCC: CERN plans 3. FCC: a view from CERN journal	Physics Case and Theory calculations J. Gluza (U.S. Katowice)	Baseline Optics I. Agapov (DESY)	Electricity & Energy Management N. Belegarde (CERN)	Environment (i) S. Kleiner (CERN)	Radetzky	Industry & Technology Day: Keynotes	Physics Performance & Detector Req. D. Elvira (FNAL)	FCC-ee Injector Overview M. Boland (USAS)	Magnets and power conversion S. Rønjasm (CMU)	SRF - Directions for R&D S. Babaezadeh (FNAL)	Radetzky	Machine Detector Interface (i) F. Pala (INFN)	SRF - technology (iii) S. Bartolome (CERN)	Integration and Radiation D. Martin (ESRF)	Synergies and innovation (i) D. Martin (ESRF)	HTS Coated Conductors S. Calatroni (CERN)	Radetzky	Summaries	08:30-09:00	
09:00-09:30	4. Opening remarks and Perspectives from Austrian Academy of Science 5. Practical information 6. Concurrence photo																			09:00-09:30	
09:30-10:00																				09:30-10:00	
10:00-10:30		Coffee Break					Coffee Break					Coffee Break					Coffee break	10:00-10:30			
10:30-11:00	Coffee break	Physics Case and Theory calculations V. Del Duca (INFN)	Alternative Optics A. Faus-Goffe (LNF)	RF Points and Cryogenics F. Caspers (CERN)	Environment (ii) B. Delle (CERN)	Radetzky	The role of Big Science R. Crescenzi (LSE)	software and Computing G. Ganis (CERN)	FCC-ee INJ Linac and Damping Ring J. Seeman (SLAC)	Vacuum F. Durrkheon (U. Hebrau)	SRF - Technology (i) C. Pira (INFN)	Radetzky	Machine Detector Interface (ii) A. Drees (BNL)	FCC-hh accelerator Optics baseline V. Shiltsev (NIU)	Safety B. Delle (CERN)	Synergies and innovation (ii) G. Lamanna (LAPP)	HTS Coated Conductors S. Calatroni (CERN)	Radetzky	Summaries	10:30-11:00	
11:00-11:30	1. Key note: From HL-LHC to FCC 2. FCC Feasibility Study status 3. FCC Collaboration status																			11:00-11:30	
11:30-12:00																				11:30-12:00	
12:00-12:30		Lunch break					Lunch break					Lunch break					Closing remarks	12:00-12:30			
12:30-13:00		Lunch break					Lunch break					Lunch break						12:30-13:00			
13:00-13:30		Lunch break					Lunch break					Lunch break						13:00-13:30			
13:30-14:00		Detector concepts M. Dam (NBI)	Tuning and Operations R. Tomas (CERN)	Civil Engineering (i) S. Calatroni (CERN)	Environment (iii) S. Calatroni (CERN)	Scientific Advisory Committee	WKO Industry session P. Sagmeister	Physics Performance & Detector Req. P. Azzi (INFN)	FCC-ee INJ Booster and transfer lines J. Wenninger (CERN)	Injection & Instrumentation S. White (ESRF)	SRF - Technology (ii) U. Van Rienen (UROS)	Radetzky	EPOL (i) A. S. Müller (KIT)	FCC-hh High Field Magnets (i) P. Vedrine (CEA)	Cooling & Ventilation, Geodesy I. Rueli (CERN)	Beam Interception Devices S. Calatroni (CERN)	HTS Coated Conductors S. Calatroni (CERN)	Radetzky	13:30-14:00		
14:00-14:30	1. Implementation Scenario 2. Civil Engineering 3. FCC Accelerator Status 4. FCC Technologies & Technical Infrastructures					FCC FES Steering Committee F. Gianotti (CERN)														14:00-14:30	
14:30-15:00																				14:30-15:00	
15:00-15:30		Coffee Break					Coffee Break					Coffee Break						15:00-15:30			
15:30-16:00	Coffee break	Detector concepts: Calorimetry and PID M. A. Pletzer (BNL)	Collective Effects L. Rivkin (PSI)	Civil Engineering (ii) M. Capozzi (CERN)	IRIS EU Project J. Guilleber		Large-scale infrastructure projects in Austria R. Gasser (MUL)													15:30-16:00	
16:00-16:30	1. Theory challenges in precision calculations 2. Flavour and BSM through measurements at 90 GeV and beyond 3. Detectors for FCC-ee - status and next steps																			16:00-16:30	
16:30-17:00																				16:30-17:00	
17:00-17:30		International Collaboration Board P. Chomaz (CEA)	Early Career Researchers										Poster session F. Sefkow (DESY)							17:00-17:30	
17:30-18:00																				17:30-18:00	
18:00-18:30																				18:00-18:30	
18:30-19:00	Welcome reception																			18:30-19:00	
19:00-19:30																				19:00-19:30	
19:30-20:00		Public event: The Higgs Boson and Our Lives National Library																		19:30-20:00	
20:00-20:30																				20:00-20:30	
20:30-21:00																				20:30-21:00	
21:00-21:30																				21:00-21:30	
21:30-22:00																				21:30-22:00	

Legend

- Plenary session
- Physics, Experiments and Detectors (PED)
- Joint PED and accelerator
- FCC-ee accelerator
- FCC-ee Injector
- FCC-hh accelerator and magnets
- Accelerator Technical Design
- SRF
- Technical Infrastructure
- Civil Engineering
- Environment
- Governance (closed session)
- Industry & Technology Day
- Early Career Researchers
- Breaks

# Agenda

## MDI (I) Convener: Fabrizio Palla

Manuela Boscolo (INFN-LNF)	MDI overview & IR mockup status
Leonard Watrelot (CERN)	Status on the MDI alignment monitoring study
Laurent Brunetti (LAPP)	FCC-ee HTS CCT magnet design proposal for the final focus quadrupole and its cooled beam pipe
Vikas Teotia (BNL)	MDI efforts at Magnet Division, BNL: Corrector Magnets and Screening Solenoid design for Interaction region of FCC-ee
Gherardo Ammirabile (INFN-Pisa)	Integration of vertex detector services and cooling

## MDI (II) Convener: Angelika Drees

Giulia Nigrelli (CERN, INFN-LNF, Uni. Sapienza)	First look at injection backgrounds
Giacomo Broggi (CERN, INFN-LNF, Uni. Sapienza)	IR beam losses and MDI collimators
Alessandro Frasca (CERN & Univ. Liverpool)	TID and Fluence in the detector and IR
Alexander Novokhatski (SLAC)	Update on IR HOM evaluations

# Feasibility Study Report - MDI Chapter

A big effort by a lot of people!

- Volume 1: <https://arxiv.org/abs/2505.00272>
- Volume 2: <https://arxiv.org/abs/2505.00274>

- Based on the detailed MDI note released in March DOI: 10.17181/w4kws-rne05: [link](#)

- Chapter 5 of the FSR in Volume 1:

■ 9 ¼ pages	5	<b>Machine-detector interface</b>	121
■ 10 Figures	5.1	Interaction region layout	122
■ 1 Table	5.2	Integration and alignment	125
	5.3	Maintenance and detector opening	126
	5.4	Beam-induced backgrounds in the detectors	128
	5.5	Implementation tests and prototyping	130
	5.6	Outlook	131

- Section 1.6 of Chap. 1 of the FSR in Volume 2:

■ 7.5 pages	1.6	Machine-detector interface (MDI)	44
■ 10 Figures			

# FCC-ee main parameters

## Final Focus optics determines the design

- Beam crossing angle of 30 mrad in x-z
  - Allows to reach high luminosity
  - Determines the luminous region size in x and z
- Beam power limited to 50 MW (due to synchrotron radiation) by design
  - determines maximum beam current per each c.o.m. energy and therefore limits the available instantaneous luminosity
  - In turn determines the no. of bunches → interaction frequency
  - Also determines the size of the beam in z together with the beamstrahlung
- Final focus superconducting quadrupoles inside the detector ( $L^*=2.2$  m)
  - Determines the luminosity and the beam size in y
- Maximum detector B-field baseline at 2 T at the Z pole
  - possibility to increase to about 2.5 T under study with non-local compensation scheme

[FSR Vol. 1, Table 14, p. 121]

	Z	W <sup>+</sup> W <sup>-</sup>	ZH	t $\bar{t}$
Beam energy (GeV)	45.6	80	120	182.5
Luminosity / IP ( $10^{34}$ cm <sup>-2</sup> s <sup>-1</sup> )	145	20	7.5	1.41
Beam current (mA)	1 294	135	26.8	5.1
Bunch number / beam	11 200	1 852	300	64
Bunch spacing (ns)	27	163	1 008	4 725
$\sigma_x^*$ ( $\mu$ m)	9.5	21.8	12.6	36.9
$\sigma_y^*$ (nm)	40.1	44.7	31.6	43.6
$\sigma_z$ (mm) SR / BS	4.7 / 14.6	3.46 / 5.28	3.26 / 5.59	1.91 / 2.33
$\sigma_\delta$ (%) SR / BS	0.039 / 0.121	0.069 / 0.105	0.102 / 0.176	0.151 / 0.184

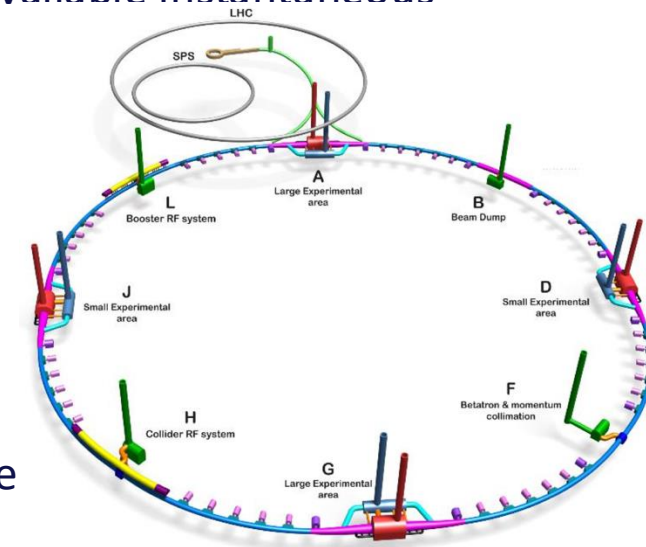

# Interaction region layout

- Beam pipes in AlBeMet (62% Be, 38% Al) up to LumiCal
- Central beam pipe 1 cm internal radius
  - Internally 5 μm gold coated to reduce impedance and shield of sync. rad. photons.
- Actively cooled due to impedance heat load
  - Liquid paraffin for the central one (~60 W) and water for the lateral ones (~130 W).
- Minimised material budget
  - Central beam pipe double wall AlBeMet, paraffin and Au (0.68% X<sub>0</sub>)
  - Lateral beam pipes minimised within LumiCal acceptance: (mostly 7% X<sub>0</sub>, few regions up to 50% of X<sub>0</sub>). Shaped to minimise showers off manifolds

[FSR Vol. 1, Fig. 82, p. 122]

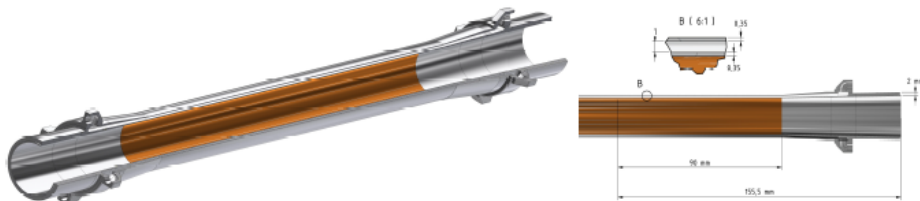
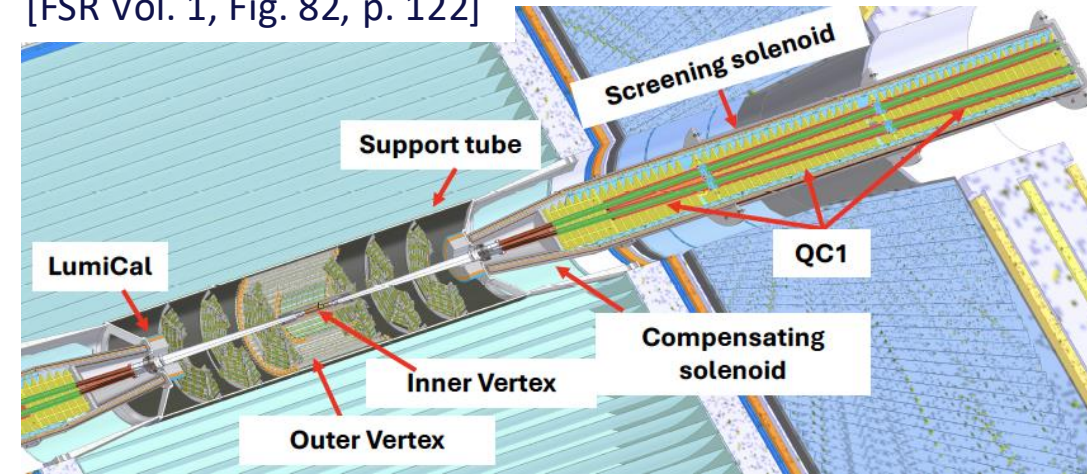

Fig. 48: Central chamber in AlBeMet162 including cooling inlets and outlets (left); cross-section view and zoom of the structure of the cooling channel for the paraffin flow.

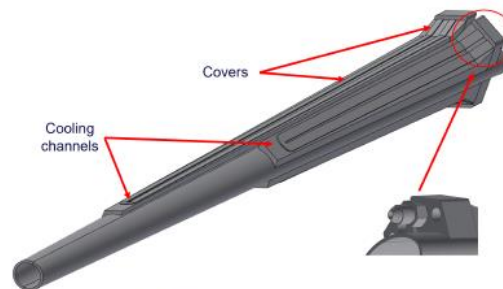

Fig. 49: Ellipto-conical vacuum chamber.

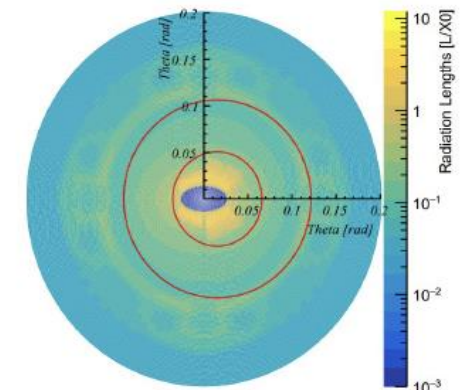
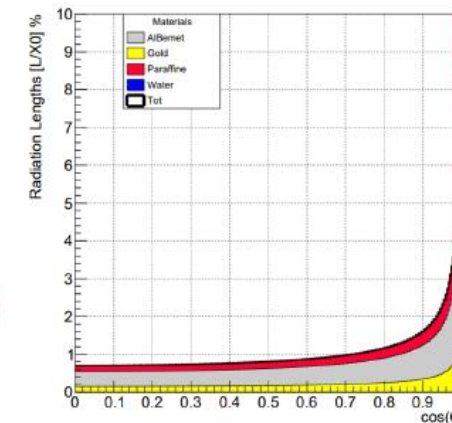
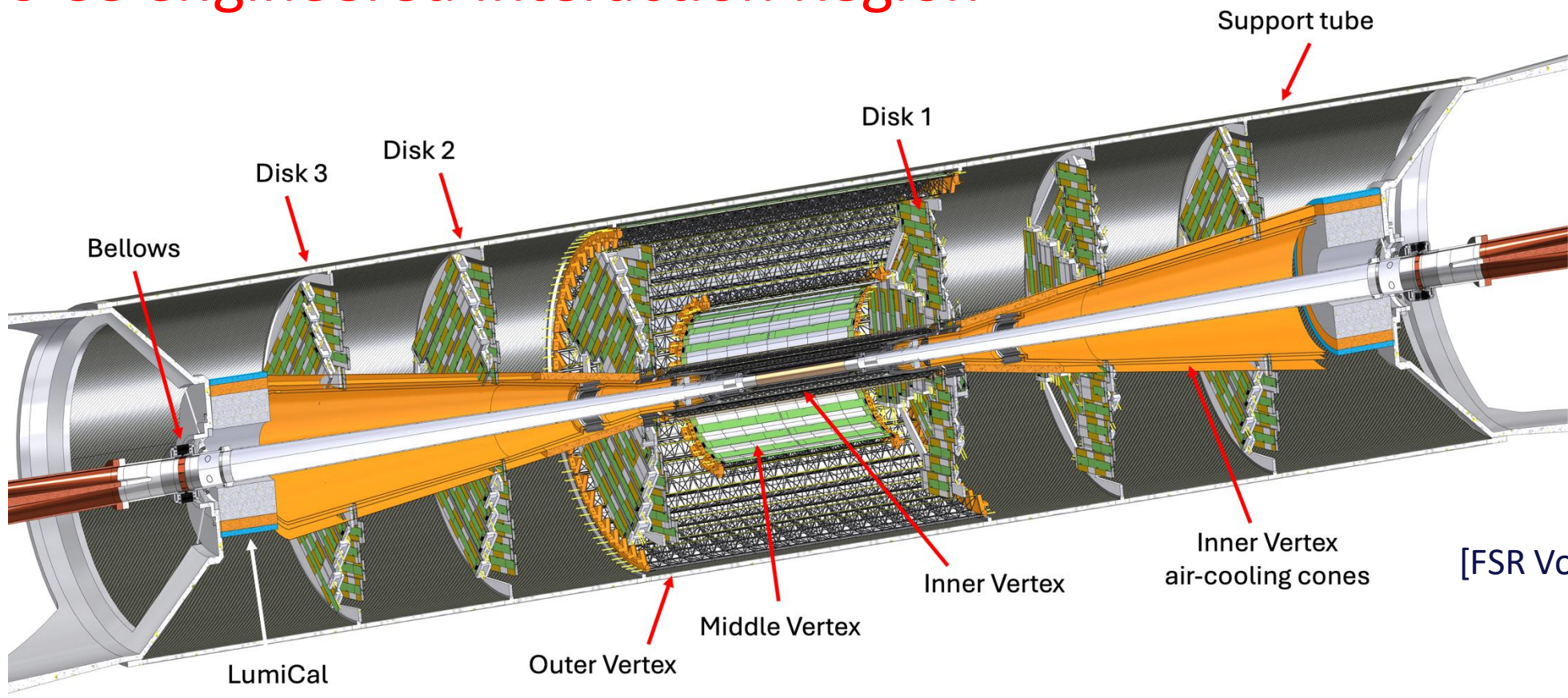

Fig. 50: Material budget of the beam pipe as a function of the polar angle (left) and in front of the LumiCal (right) in the region  $\theta \in [0, 0.2]$  rad. The red lines represent the LumiCal acceptance, i.e. the 50 mrad and 105 mrad cones.

# FCC-ee engineered Interaction Region



[FSR Vol. 1, Fig. 88, p. 125]

**Support tube provides integration of beam pipes, vertex and LumiCal**

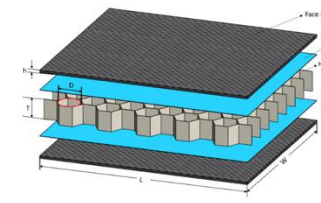

Support tube material  
1mm CF + 4mm HC + 1mm CF

Ref: M. Boscolo, F. Palla, et al., *Mechanical model for the FCC-ee MDI*, EPJ+ Techn. and Instr., <https://doi.org/10.1140/epjti/s40485-023-00103-7>

# FCC-ee engineered Interaction Region

See Gherardo Ammirabile's presentation

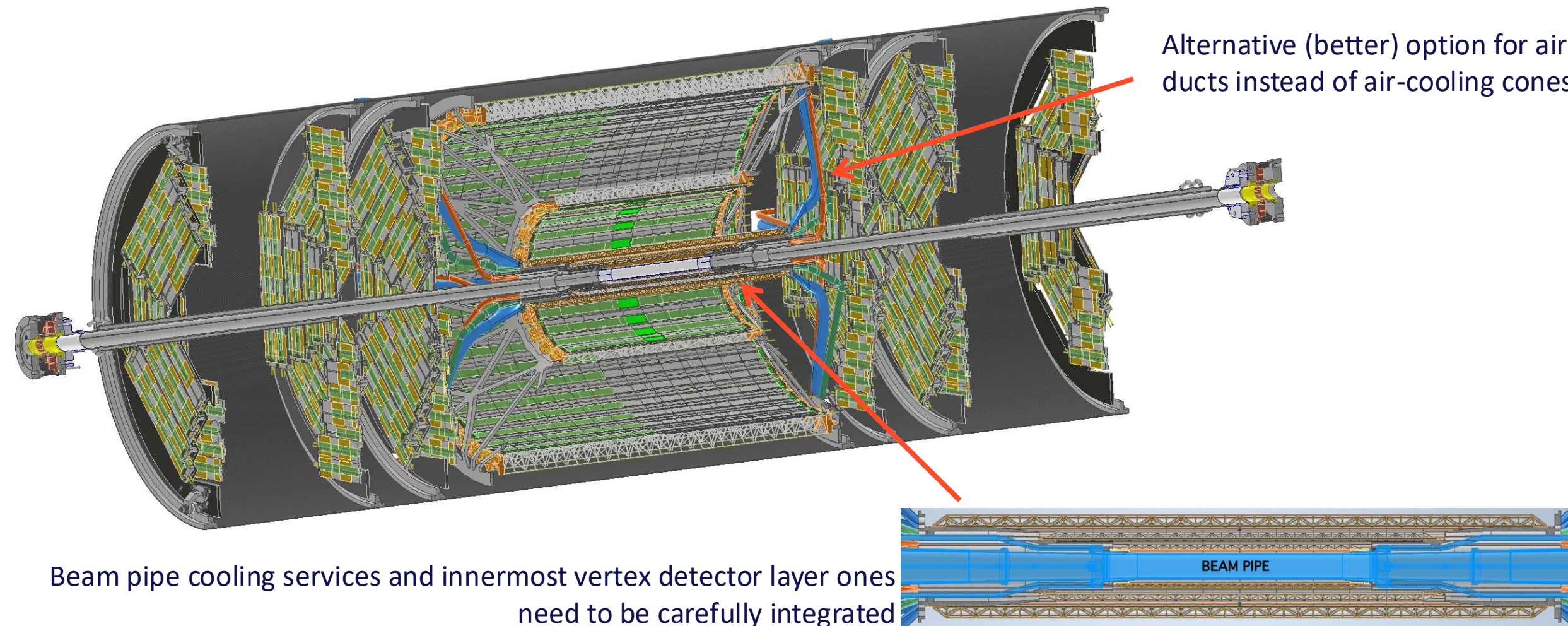

IDEA detector based, pre-TDR: same exercise to be done for the other 3 detector concepts

# IR superconducting magnets

- **Final focus quadrupole QC1**
- **Screening solenoid** (*design depends on detector magnet*)
- **Correctors**
- **Compensating solenoid** (only for *local* solenoid compensation scheme)

talk by L. Brunetti

[FSR Vol. 1, Fig. 82, p. 122]

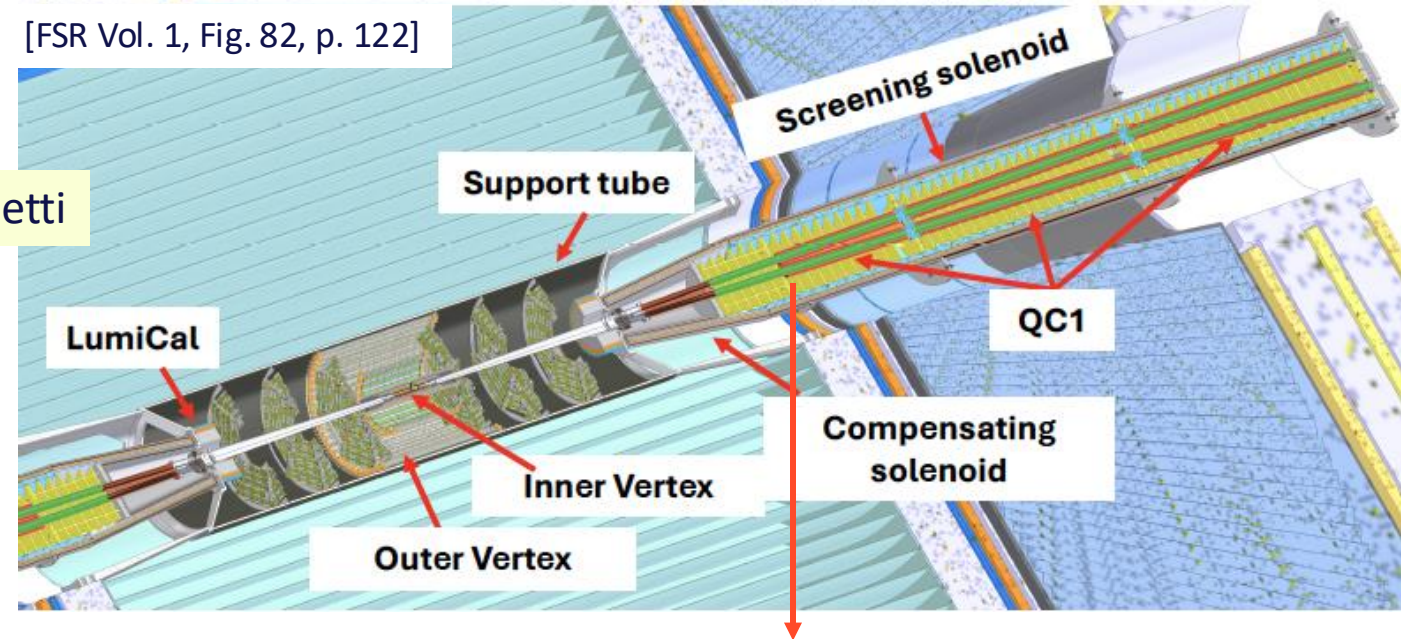

All inside the detector !

Space budget is hard, especially at 2.2m. Study to increase  $L^*$ , and/or crossing angle, free space between QC1 and QC2.

See talk by K. Oide

Some constraints for the design:

- The **acceptance of the cryostat** currently covers a **cone of 100 mrad** around the z axis.  
(To be confirmed by next physics performance studies)
- Detector magnet - First meeting to start with this design took place last week.

see talk by V. Teotia

# Maintenance and accessibility of the detectors

Three options for opening the detector in the caverns

## 1. longitudinal shift

- FFQ and other machine elements beyond detector endcaps shall be removed (with their supports). BP vacuum broken also in cold pipes. Realignment of the machine needed.

## 2. longitudinal + transverse shift

- Split endcaps significantly deteriorate detector precision measurements. BP vacuum stay (or Ne flushing), no realignment needed.

## 3. Transversal shift of the full detector and the FFQ assembly (parking position), then extraction of the FFQ and full longitudinal opening of the detector endcaps

- Optimal detector acceptance. FFQ assembly stays inside the detector, temporarily supported by the detector's endcaps. Machine elements beyond detector endcaps also stay in place. BP vacuum broken for detector beampipe. Realignment needed
- Can only be done for large caverns

**concept to be developed in the next pre-TDR phase**

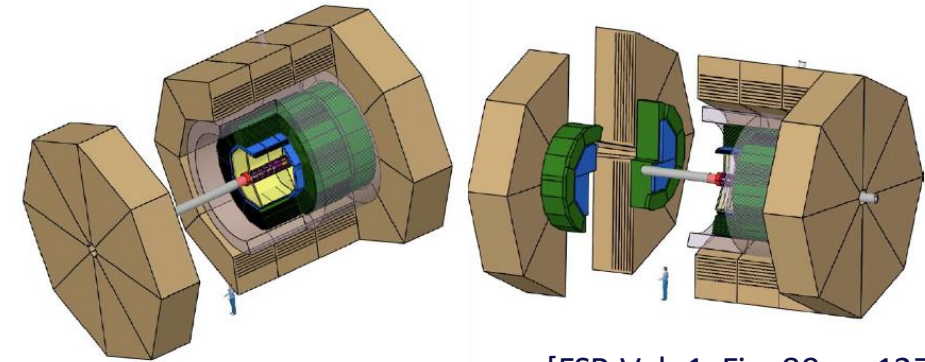

[FSR Vol. 1, Fig. 89, p. 127]

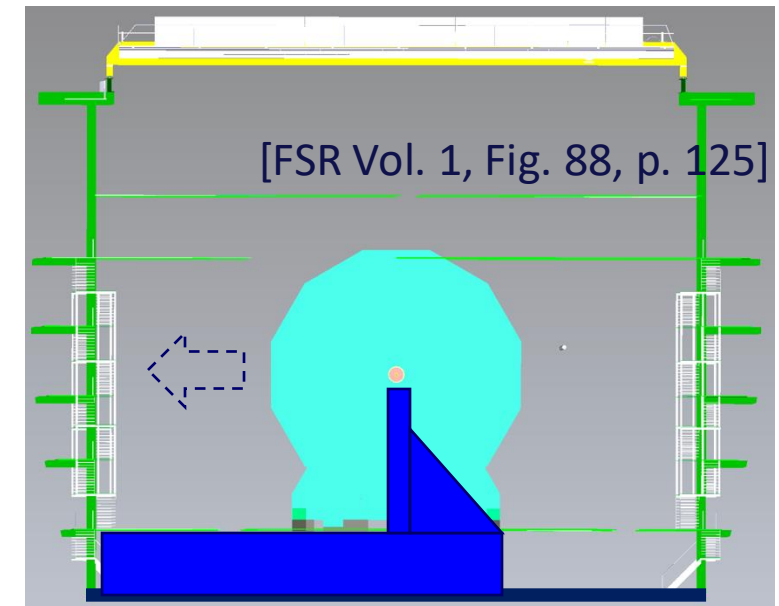

[FSR Vol. 1, Fig. 88, p. 125]

# Solenoid compensation scheme

Two schemes to compensate the coupling induced by the detector field.

## Local solenoid compensation scheme (Baseline design)

- Strong anti-solenoid (-5 T) in front of QC1

## Non-Local solenoid compensation scheme

inspired to scheme proposed at DAFNE by M. Bassetti (\*)

Scheme implemented in SAD and MADX, independently, for LLC optics

This solution is optics independent

- Anti-solenoid outside the detector (~ 10 m from the IP )
- Skew quads windings around FFQs
- Weak corrector dipoles
- Advantages:
  - Allows to increase detector B field (about 2.5 T) due to the good coupling compensation
  - Strong reduction of the synchrotron radiation produced at the IR
- The tuning knobs are needed for orbit and coupling correction for all optics.
- Equilibrium **polarization** in progress see talks by Yi Wu and K. Oide

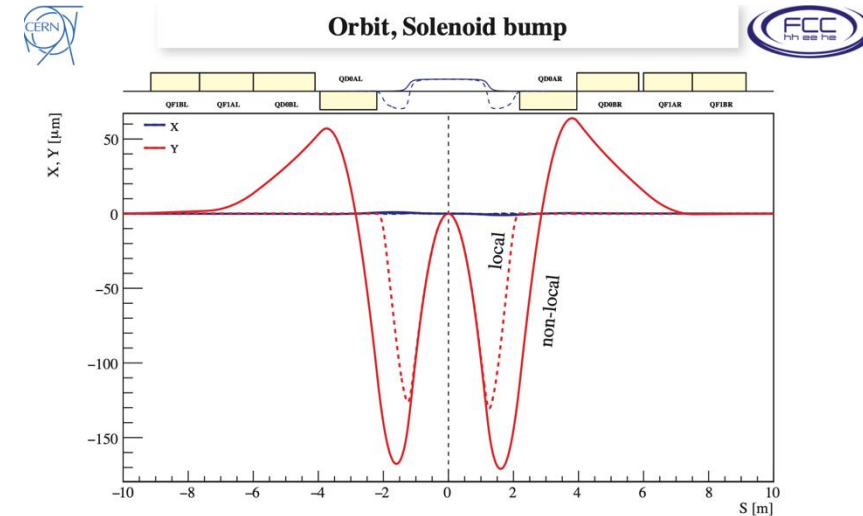

Courtesy of H. Burkhardt  
MDI meeting #66, 12/5/25 [link](#)

(\*) Frascati Phys. Ser., 10:209-214, 1998 [link](#)

# Beam Induced backgrounds (BIB)

## Two classes of backgrounds: single beam and colliding beams induced

### Single beam induced:

- Beam halo losses
- Beam-gas: Coulomb and Bremsstrahlung (NEW results!)
- Synchrotron radiation caused by deviation to the zero-orbit and beam tails
- Intra-beam scattering (Touschek) NEW!
- Injection background NEW!
- Fast instability NEW!

### Colliding beams induced:

- Incoherent Pair Creation (IPC)
  - new studies on materials at Y- pipe
- Radiative Bhabha  $e^+e^- \rightarrow e^+e^-\gamma$
- Losses of collision spent beams

- Fluences and Ionization doses studies extending at larger radii

Ongoing studies to validate simulation tool with SuperKEKB data

talks by  
G. Broggi, A. Frasca, G. Nigrelli

## Software framework in place to study BIB, to compute data rates and occupancies

- FLUKA model to track particles up to the interface plane (beam pipe)
- Data format for detector backgrounds studies defined
- There is a WP in DRD8 to translate CAD into GEANT

see talk by B. François

# Backgrounds from Y-beam pipe

A.Ciarra, MDI meeting #66, 12/5/25 [link](#)

## Motivation

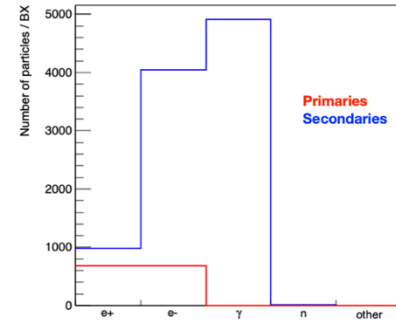
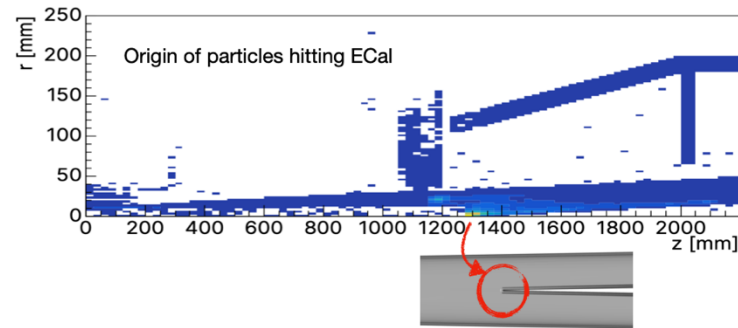

A large contribution of backgrounds come from secondaries generated by low-Pt particles hitting the beam pipe separation region.

Large production of electrons and photons from copper beam pipe material.

**Different Y-pipe material** (with respect to copper) reduces secondaries, equivalent to the effect of a 2 cm of tungsten shielding (and much lighter!)

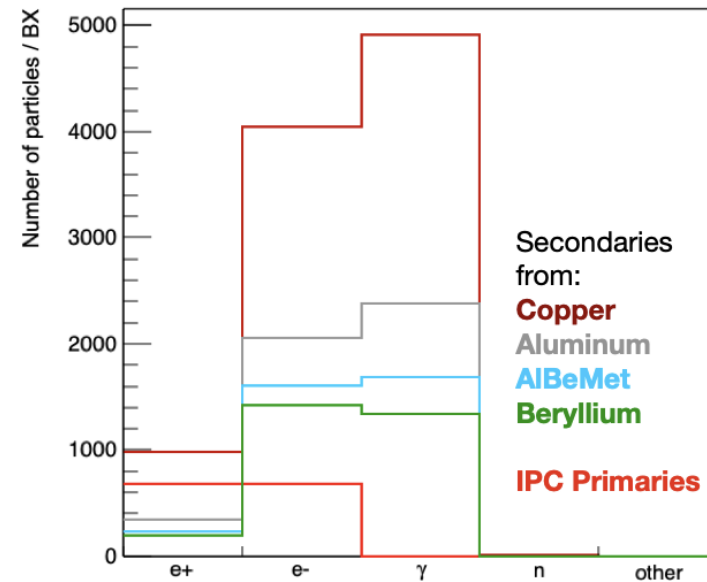

# Full scale mock-up of the interaction region

Vacuum chambers in aluminium

Inner vertex in carbon fibre and kapton heaters (no MAPS)

Outer vertex and disks in aluminium

Vertex services

Support tube in carbon fibre and honeycomb

Lumical 3D printed

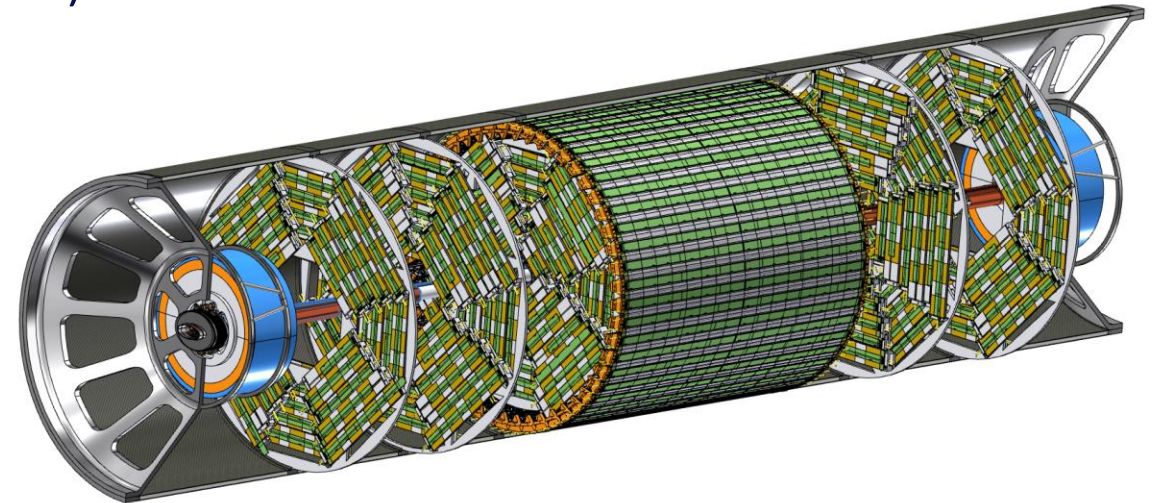

## Integration goals

Vacuum chambers cooling, integration with the beam pipe (inner vertex and lumical) and with support tube (outer vertex and disks), air-cooling and cables routing, test assembly procedure.

## Status of measurements and validations

- **Verify active cooling system of the detector beam pipes (Frascati)**
  - ✓ Central chamber: measurement with water as liquid coolant
    - Central chamber: measurement with liquid paraffin
    - Ellipto-conical chambers: measurements with water
- **Verify air-cooling efficiency for inner vertex detector (Pisa)**
  - Wind tunnel under construction
- **Assembly test and validation**



Under evaluation the possibility to use the mockup for alignment

(see L. Watrelot's talk)

# Measurement set-up

PT1000 sensors:  
3 on the central chamber  
1 on each water collector  
1 environment



internal ohmic heater

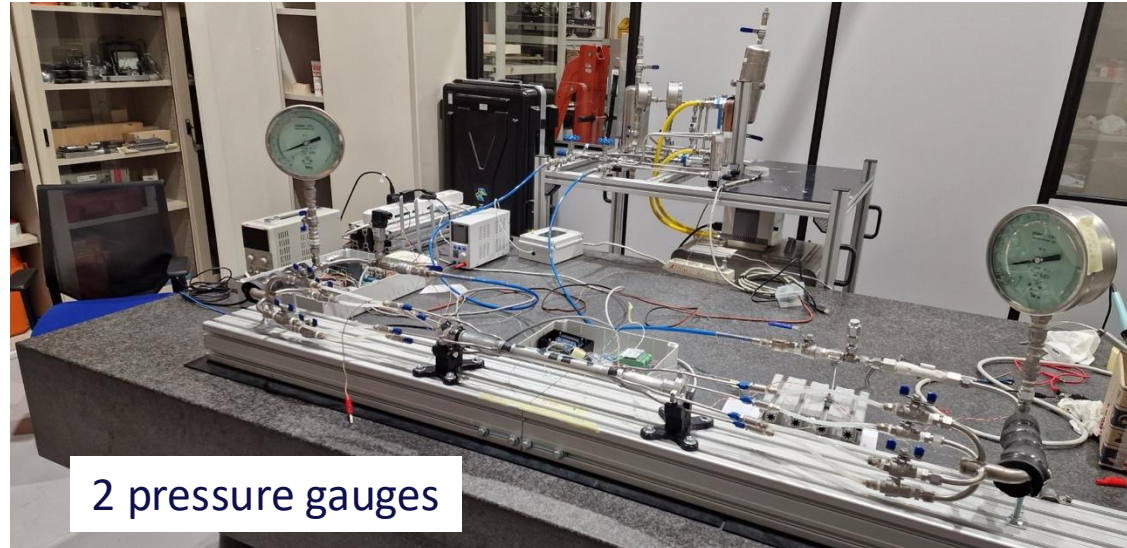

2 pressure gauges

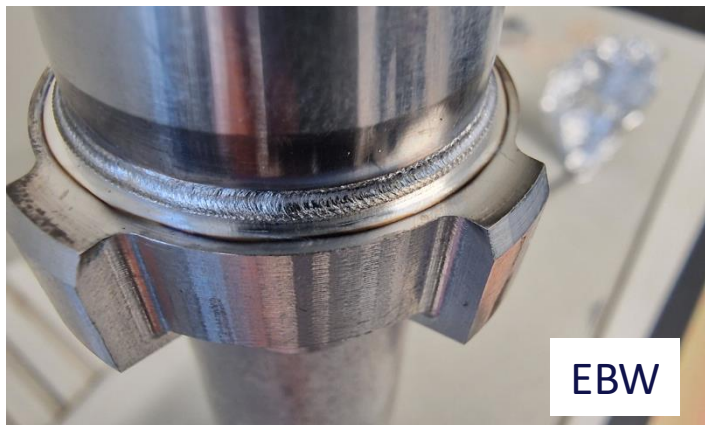

EBW

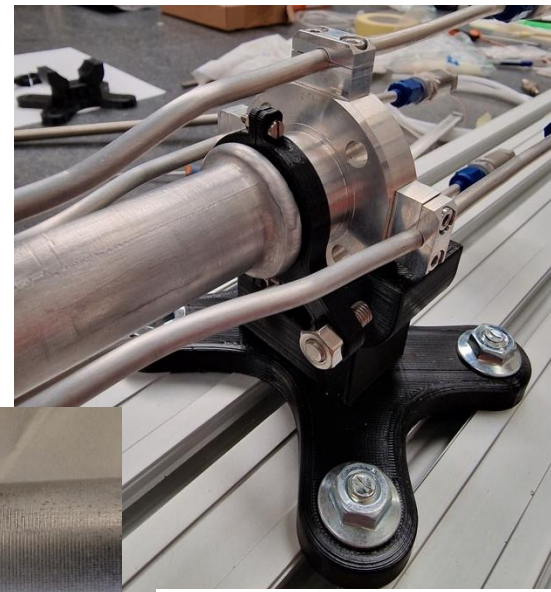

cooling pipes manifolds

Vacuum chambers manufactured by COMEB s.r.l. (Italy)



<http://www.comeb.it/>

Electron Beam Welding (EBW) by Ravenscourt Eng. Limited (UK)



<https://ravenscourteengineering.co.uk/>

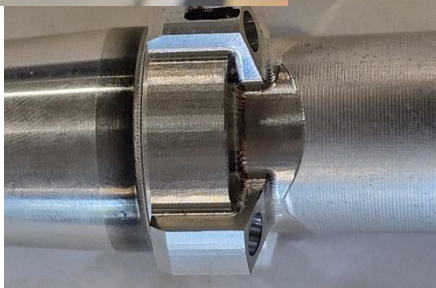

# Measurements with water coolant for the central chamber

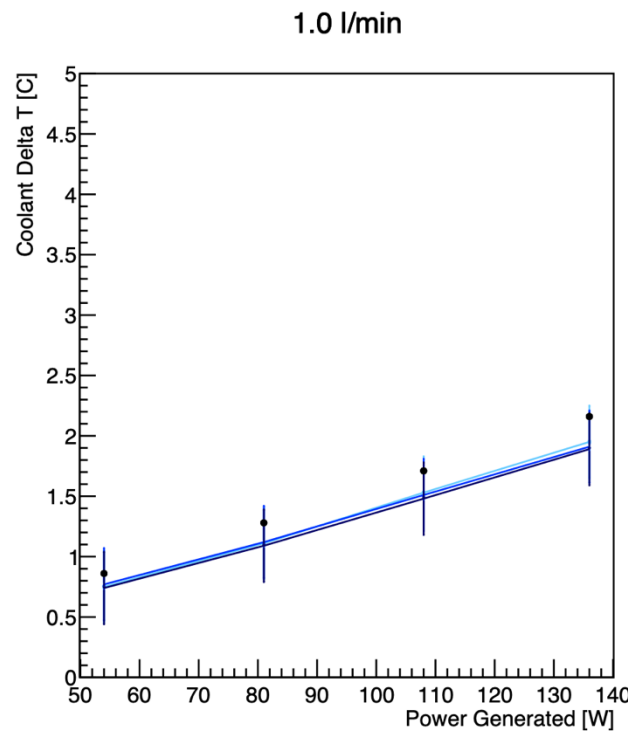
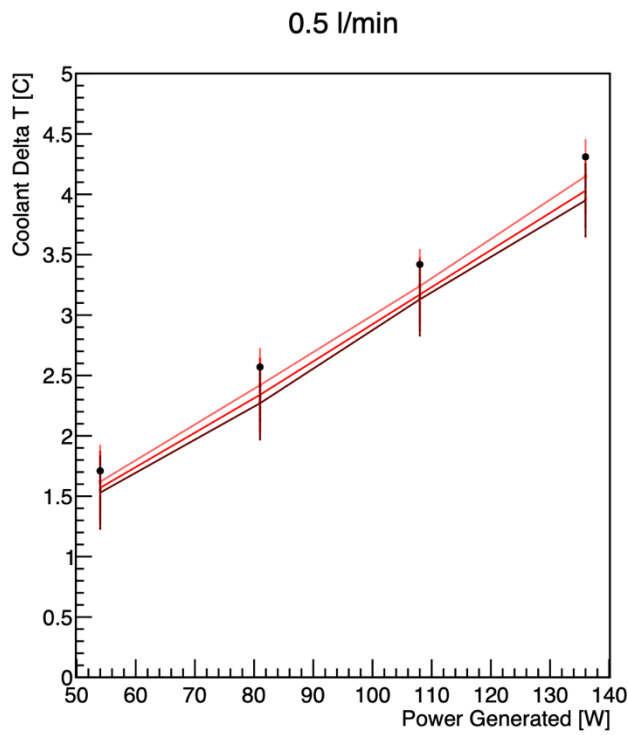

Measurements of the coolant temperature versus the power of the beam pipe in agreement with expectations.

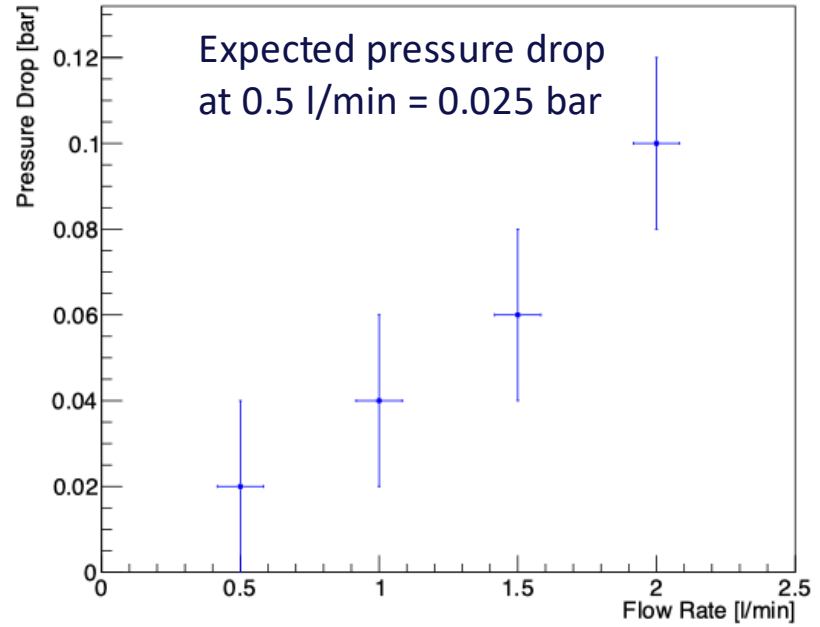

Behaviour of the pressure drop versus the flow rate as expected.

The system allows for large safety margins operations.

Next tests with liquid paraffin foreseen in June and July.

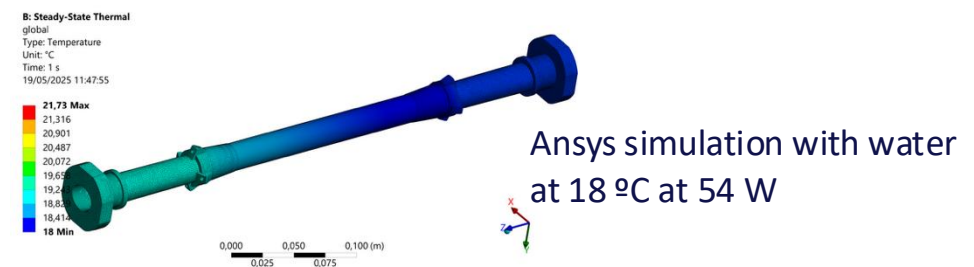

# Impedance heat load of the detector beam pipe

**Ansyes simulations to evaluate the impedance heat load at the Z**

P = 54 W central pipe

P = 130 W each side of the conical pipe

**The intensity run at the Z requires active cooling of the beam pipes**

see talk by A. Novokhatski

With a simple rescaling of beam parameters, the expected heat loads at higher energies are:

	Z	WW	ZH	ttbar
Central pipe	54 W (Ansys)	4.0 W	0.6 W	0.15 W
Conical pipe	130 W (Ansys)	9.5 W	1.4 W	0.4 W

(courtesy of C. Zannini)

**Indication is that no active cooling needed at higher energies! In the next pre-TDR phase, we could study different beam pipes for various beam energies.**

### Disclaimers

- in this rescaling the shorter bunch length (esp. at ttbar) is not taken into account
- an accurate evaluation and confirmation of these values require dedicated impedance simulations.

**Note:** To these values we must add the heat load due to synchrotron radiation.

# Summary & Outlook

- The feasibility study detailed results in shaping the IR of FCC-ee
- Next steps will sharpen remaining topics:
  - More BIB ready for detector backgrounds evaluations
  - Solenoid compensation optics
  - IR correctors
  - Deeper understanding of services in congested areas
  - Detector assembly and maintenance
  - Several mockups ongoing
- Outstanding remaining design optimisations:
  - FFQs
  - Remote vacuum connection
  - IR diagnostics

MDI monthly meetings: <https://indico.cern.ch/category/5665/>  
e-group: fcc-ee-MDI@cern.ch



And thank you to many people for inputs!

# Backup

# FF Optics

K. Oide

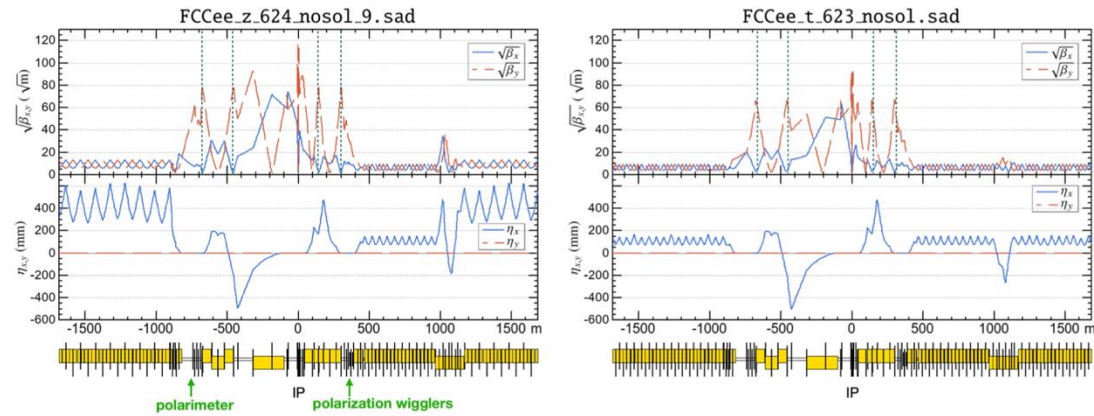

Fig. 1.6: Layout and optics for the experiment straight section: Z/W operation modes (left) and ZH/tt operation modes (right). This section includes sections for an inverse-Compton polarimeter and polarisation wigglers. The vertical lines show the location of the sextupoles for vertical local chromaticity correction and crab waist.

# LCC Optics

P. Raimondi

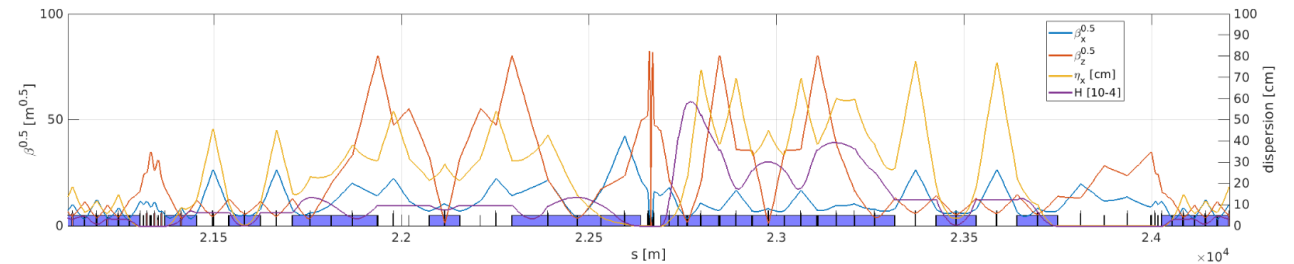

Fig. 1.46: LCC FF optics at tt. The same layout is used at Z.

# LCCO: Local Chromatic Correction Optics

# Non-local Solenoid Compensation Scheme

Perfect compensation of orbit, dispersion coupling with

- 3 rather weak orbit corrections each side of the IP
- small skew components to the FFQs (equivalent to 10 mrad rotation)
- anti-solenoid at 11m from the IP.

**Vertical emittance increase is very small ( $\leq 100$  fm at Z pole)**

- **Allows to increase detector B field up to about 2.5 T** contrary the local scheme, due to a better coupling compensation
- **Going from 2T to 2.5 T detector solenoidal field improved the tracks'  $p_T$  resolution by about 25 %**
- **Factor of 2 lower SR at the IR**
- **Depolarisation**, anyway solvable with e+e- polarised injector, seem to be very small according to first BMAD simulations.

<https://doi.org/10.18429/JACoW-IPAC2024-TUPC68>

# Solenoid Coupling Compensation Scheme

Longitudinal and radial magnetic fields along the 15 mrad axis

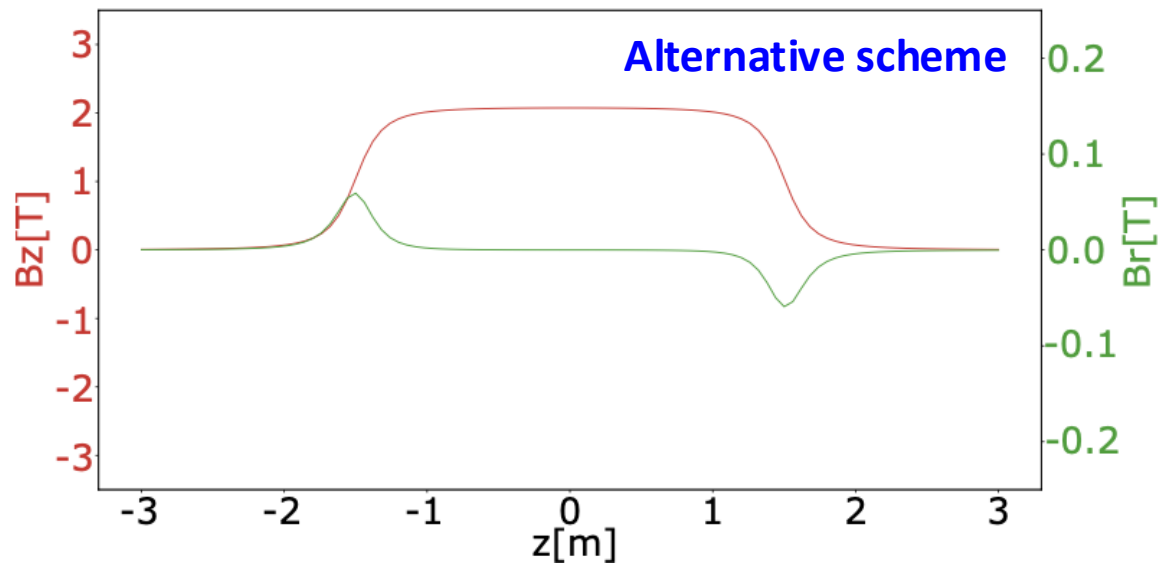

Synchrotron radiation power 12 kW

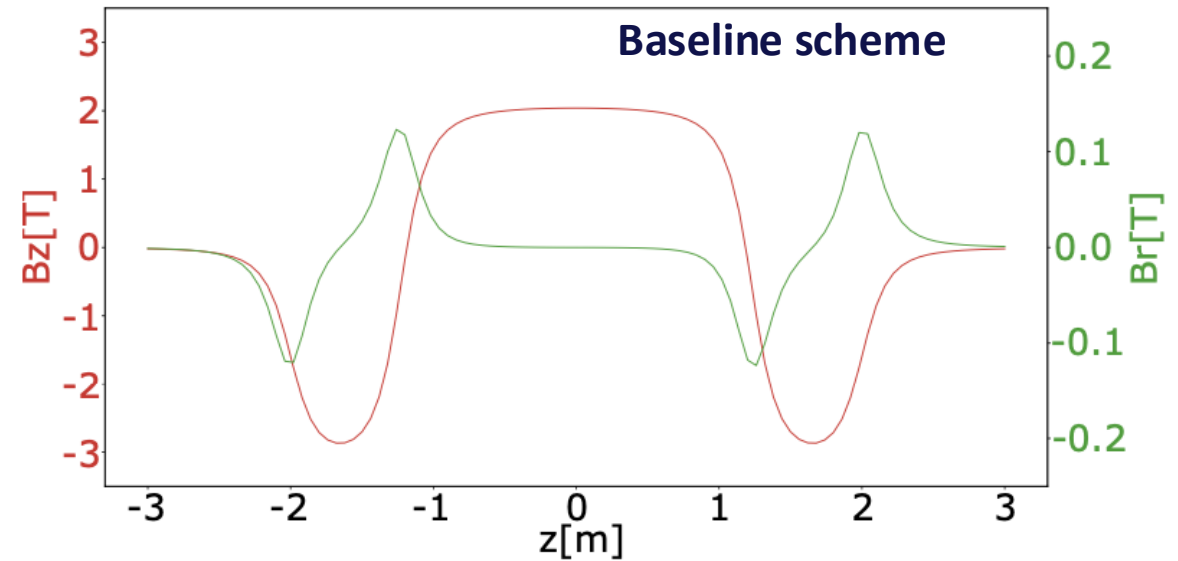

Synchrotron radiation power 80 kW

# Synchrotron Radiation Backgrounds

Courtesy of Kevin Andrè

- SR simulations performed with BDSIM (Geant4 based) including X-ray reflection
- SR collimator and masks implemented at optimised positions
- Realistic conditions studied

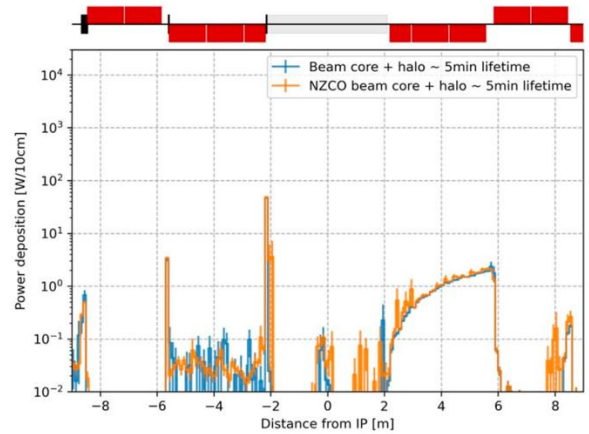

**GHC - SR power deposition summary,**  
1% of the particles in the tails, with beam lifetime equivalent to 5 min, and 100  $\mu\text{m}$  std in X&Y and 6  $\mu\text{rad}$  std in PX&PY applied to the beam core (NZCO).

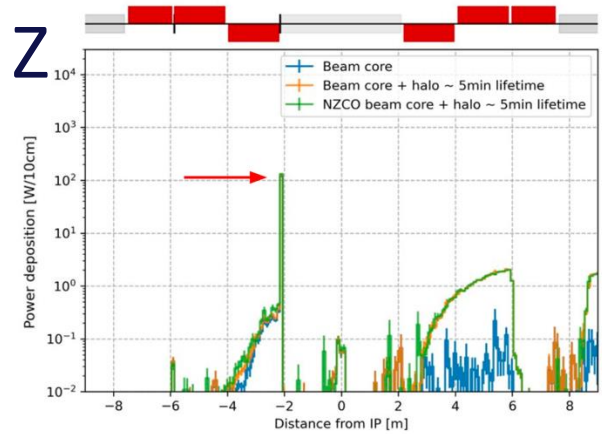

**LCC - SR power deposition summary,**  
1% of the particles in the tails, with beam lifetime equivalent to 5 min, and 100  $\mu\text{m}$  std in X&Y and 6  $\mu\text{rad}$  std in PX&PY applied to the beam core (NZCO).

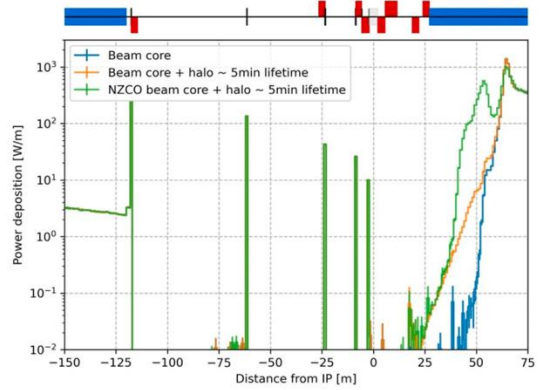

**GHC - SR power deposition summary,**  
1% of the particles in the tails, with beam lifetime equivalent to 5 min, and 100  $\mu\text{m}$  std in X&Y and 6  $\mu\text{rad}$  std in PX&PY applied to the beam core (NZCO).

tt

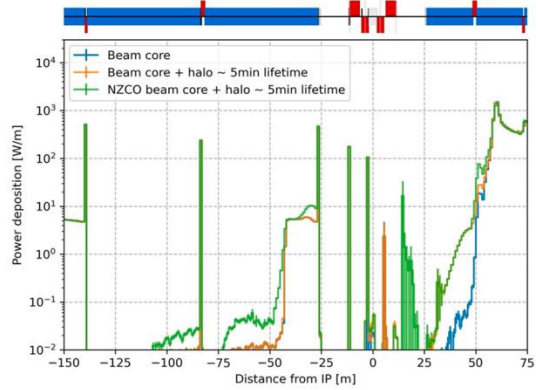

**LCC - SR power deposition summary,**  
1% of the particles in the tails, with beam lifetime equivalent to 5 min, and 100  $\mu\text{m}$  std in X&Y and 6  $\mu\text{rad}$  std in PX&PY applied to the beam core (NZCO).

To be tracked inside the detector

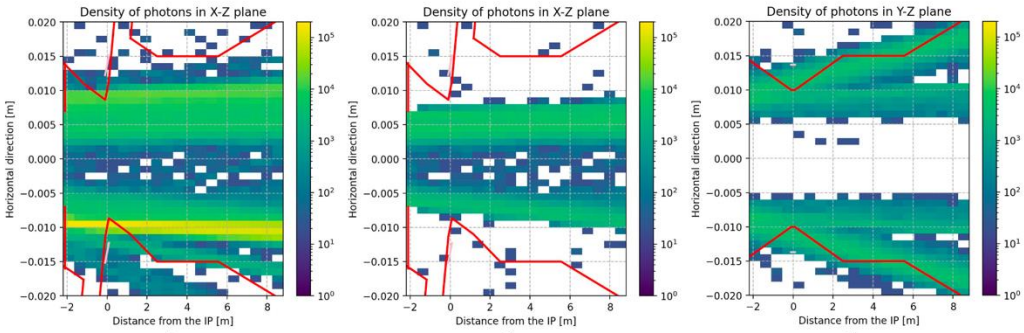

Including the mask aperture  $x > 7\text{mm}$

SR masks

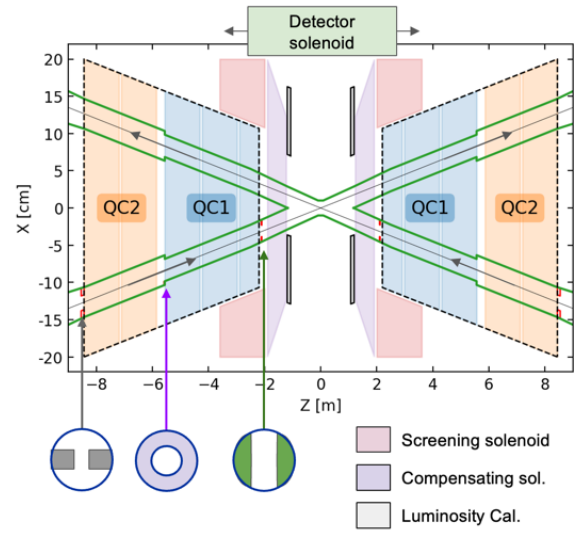

see talk by Giacomo Broggi

# Beam losses in the IR

- Beam halo losses
- Beam-gas bremsstrahlung and Coulomb losses

## Beam-gas bremsstrahlung IR losses (Z-mode)

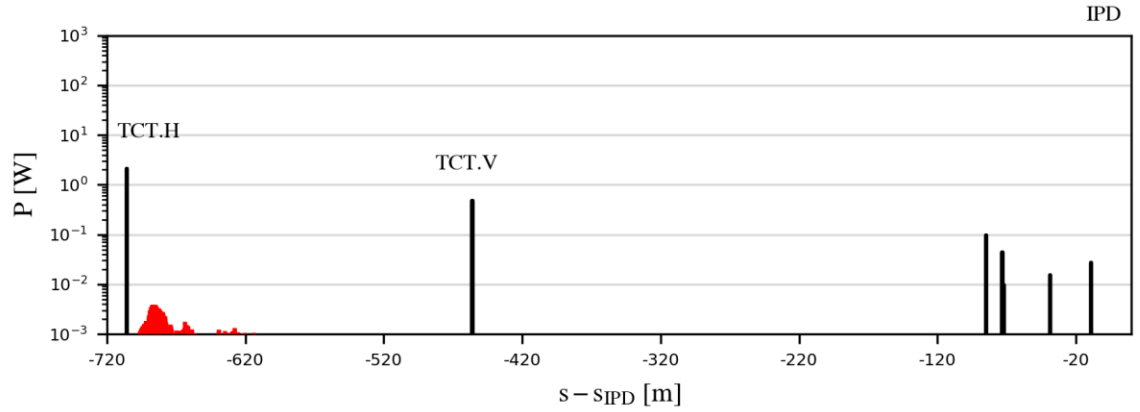

Estimated lifetime ~ 282 min\*

\*1h beam conditioning at full nominal current (1.27 A): pressure is expected to condition down further (up to a factor ~100) over time

## Beam-gas Coulomb scattering IR losses (Z-mode): driven by limited vertical DA

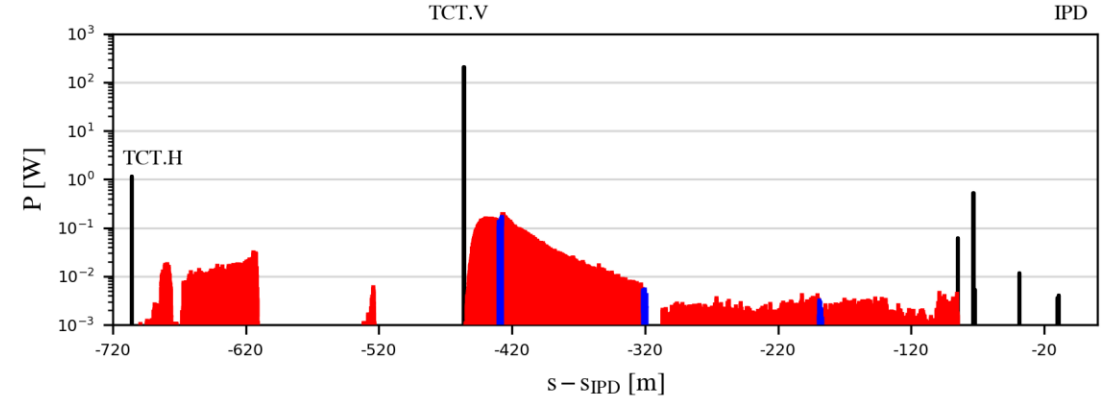

Estimated lifetime ~ 45 min\*

## Losses to be tracked in the detectors:

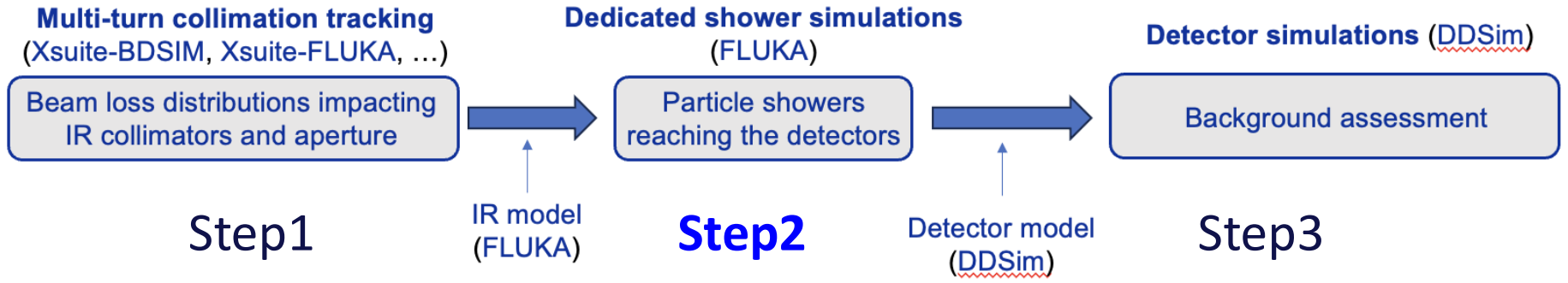

# Engineered detector beam pipe

- Thermal and Structural simulations
- Impedance simulation

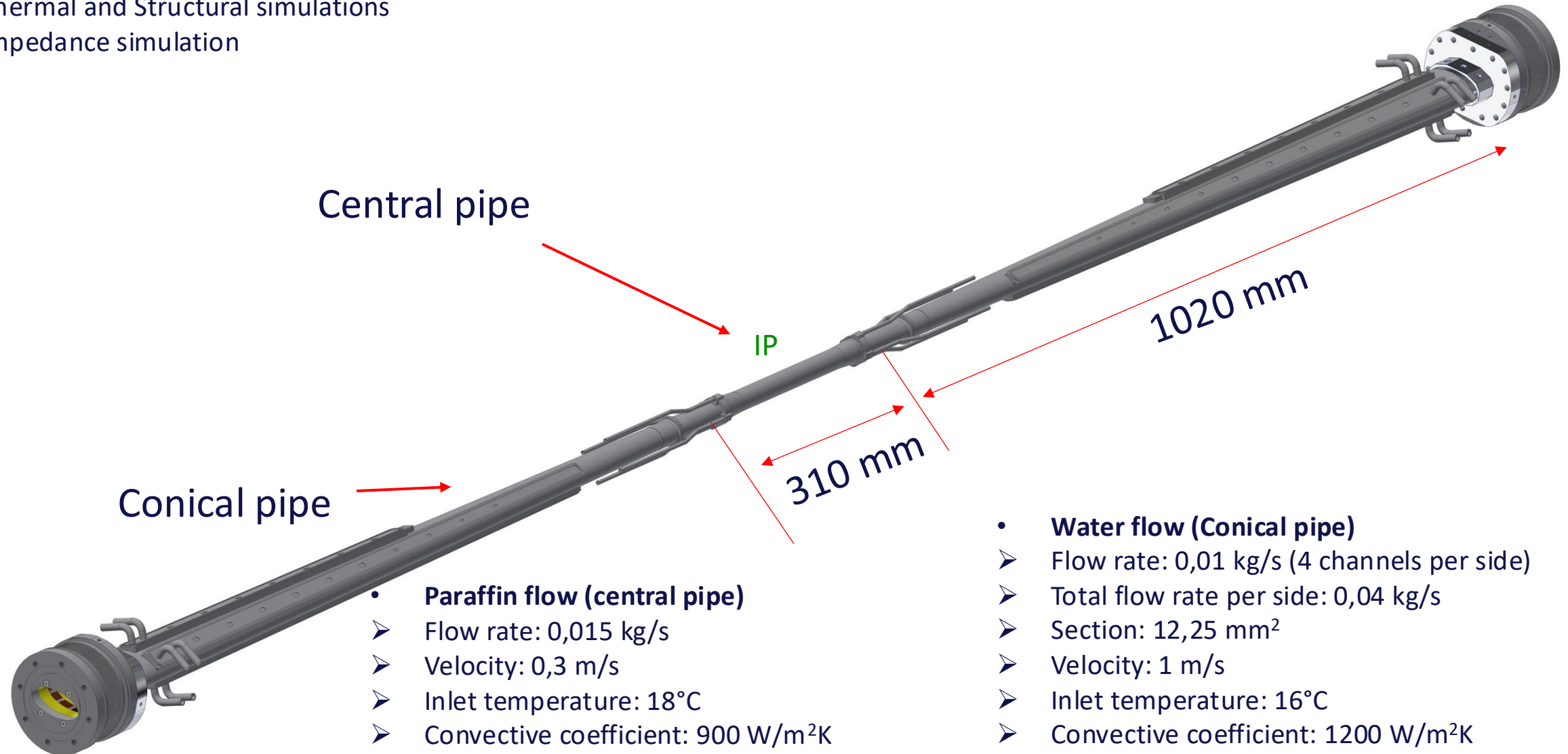

- **Paraffin flow (central pipe)**
  - Flow rate: 0,015 kg/s
  - Velocity: 0,3 m/s
  - Inlet temperature: 18°C
  - Convective coefficient: 900 W/m<sup>2</sup>K

- **Water flow (Conical pipe)**
  - Flow rate: 0,01 kg/s (4 channels per side)
  - Total flow rate per side: 0,04 kg/s
  - Section: 12,25 mm<sup>2</sup>
  - Velocity: 1 m/s
  - Inlet temperature: 16°C
  - Convective coefficient: 1200 W/m<sup>2</sup>K

# FCC-ee IR Magnets

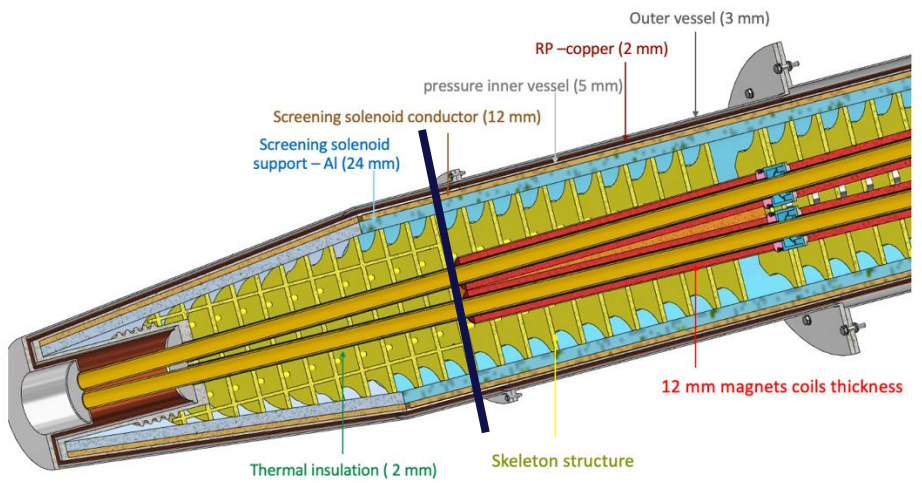
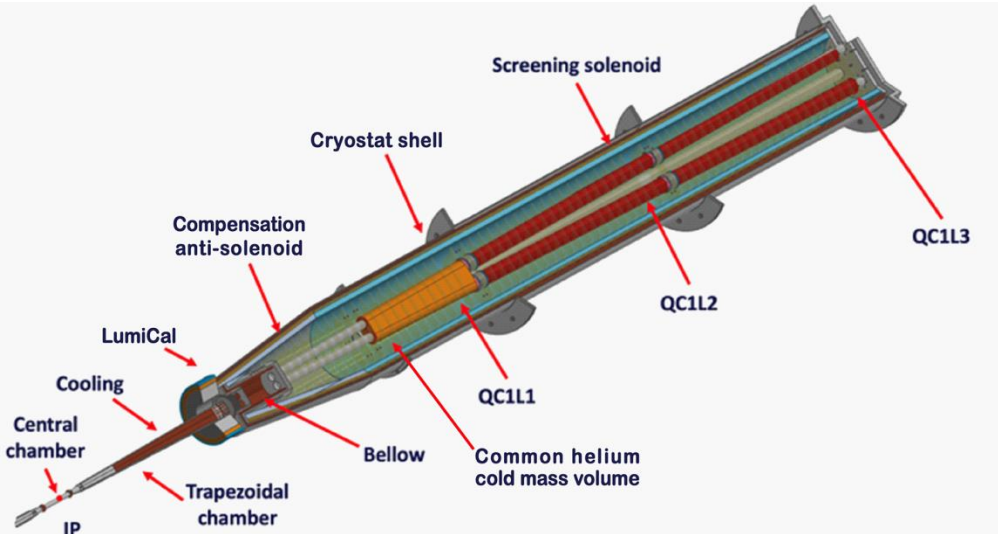

## Cold tests on first segment prototype of QC1L1: IPAC24-WEPS65

15th International Particle Accelerator Conference, Nashville, TN  
 ISBN: 978-3-95450-247-9 ISSN: 2673-5490 JCoW Publishing  
 doi: 10.18429/JCoW-IPAC2024-WEPS65

### THE FIRST SUPERCONDUCTING FINAL FOCUS QUADRUPOLE PROTOTYPE OF THE FCC-ee STUDY

A. Thabuis, M. Koratzinos, G. Kirby, M. Liebsch, C. Petrone  
 European Organization for Nuclear Research (CERN), Geneva, Switzerland

Integration of complete cryostat with magnets, correctors, and diagnostics is required. Study has started.

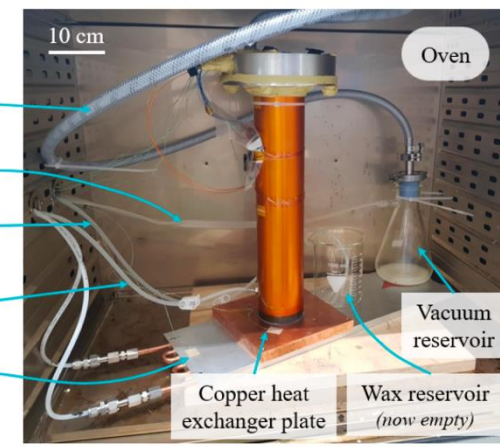

### IR Magnet Cross Section View (front and end of each magnet)

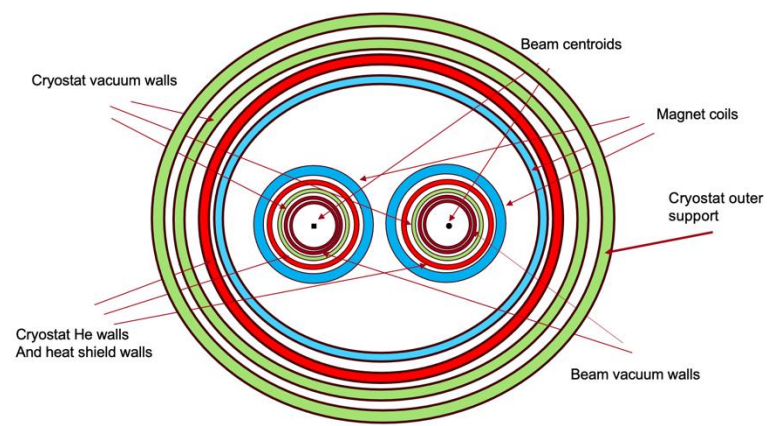

IR QC1 and QC2 in different cryostats but one integrated raft seems the best solution