

An announcement ...

Capturing the experience:

- Anecdotes about the experience
(excitement of coming, losing the luggage, surprises along the way, things you liked from the city,...)
 - Develop one topic from what you learned into plans for activities or content for your students
 - Lessons to share with teachers
-
- It can be either individually or as a group.
 - A few pages per teacher on average would be great
(example: if it were an average of 5 each → 130 pages)

An announcement ...

- Please include –as an addendum– any advice you have for our teachers’ programs.
- Deadline: August 19.
 - Please send to Kenny, MCC and me.
- We will have a sharing session on August 24
- We will invite the Croucher Foundation

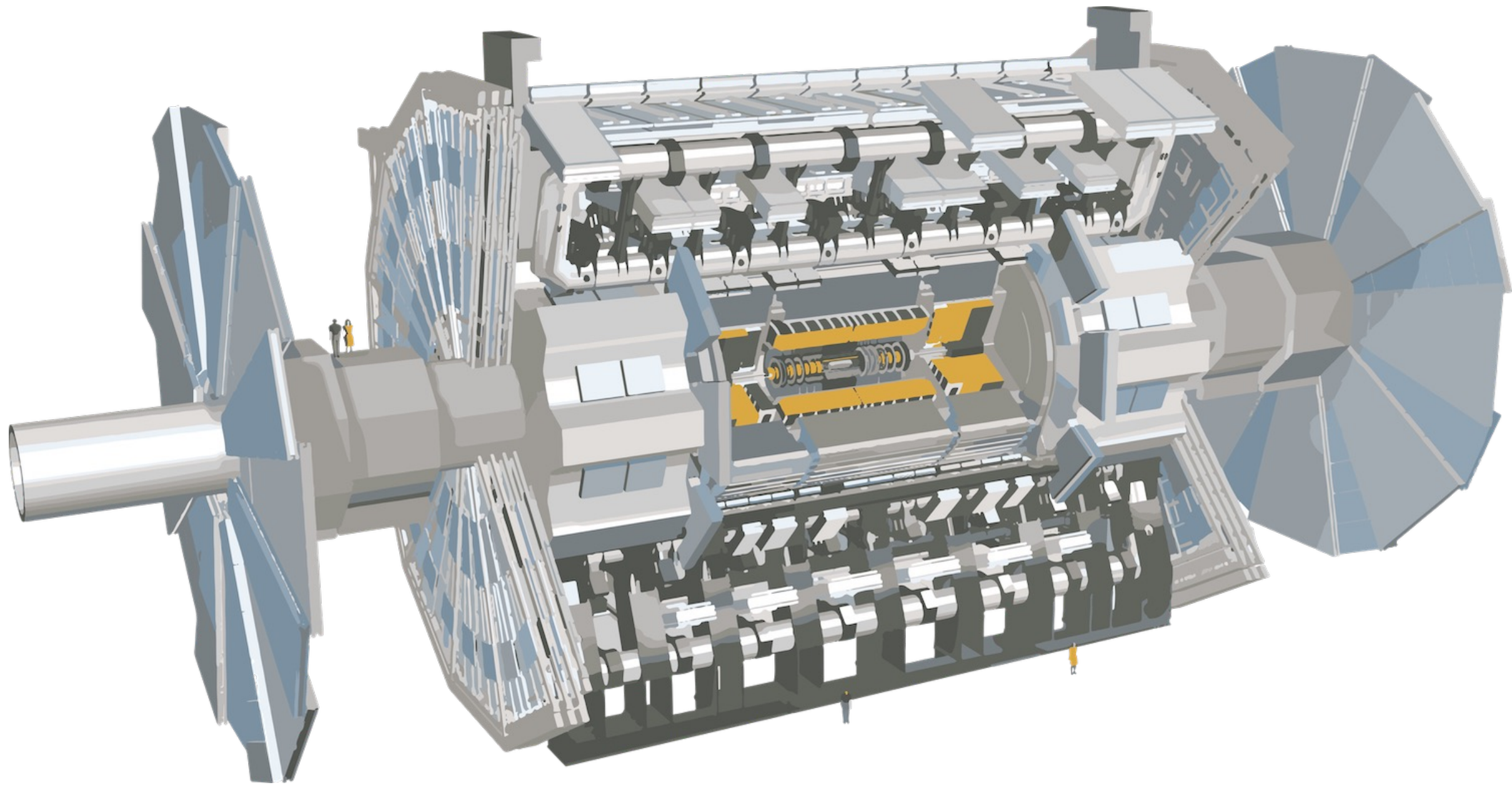

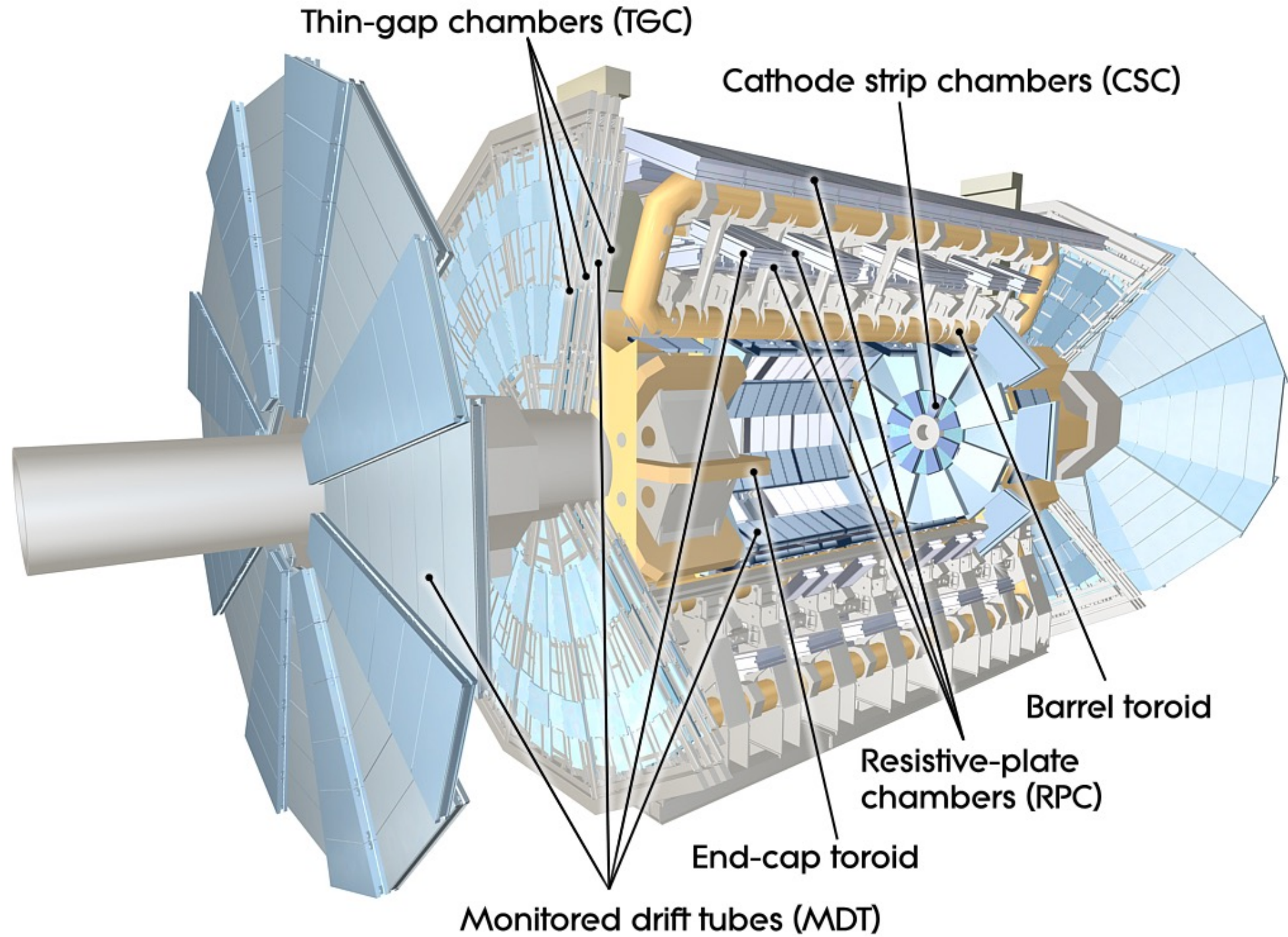

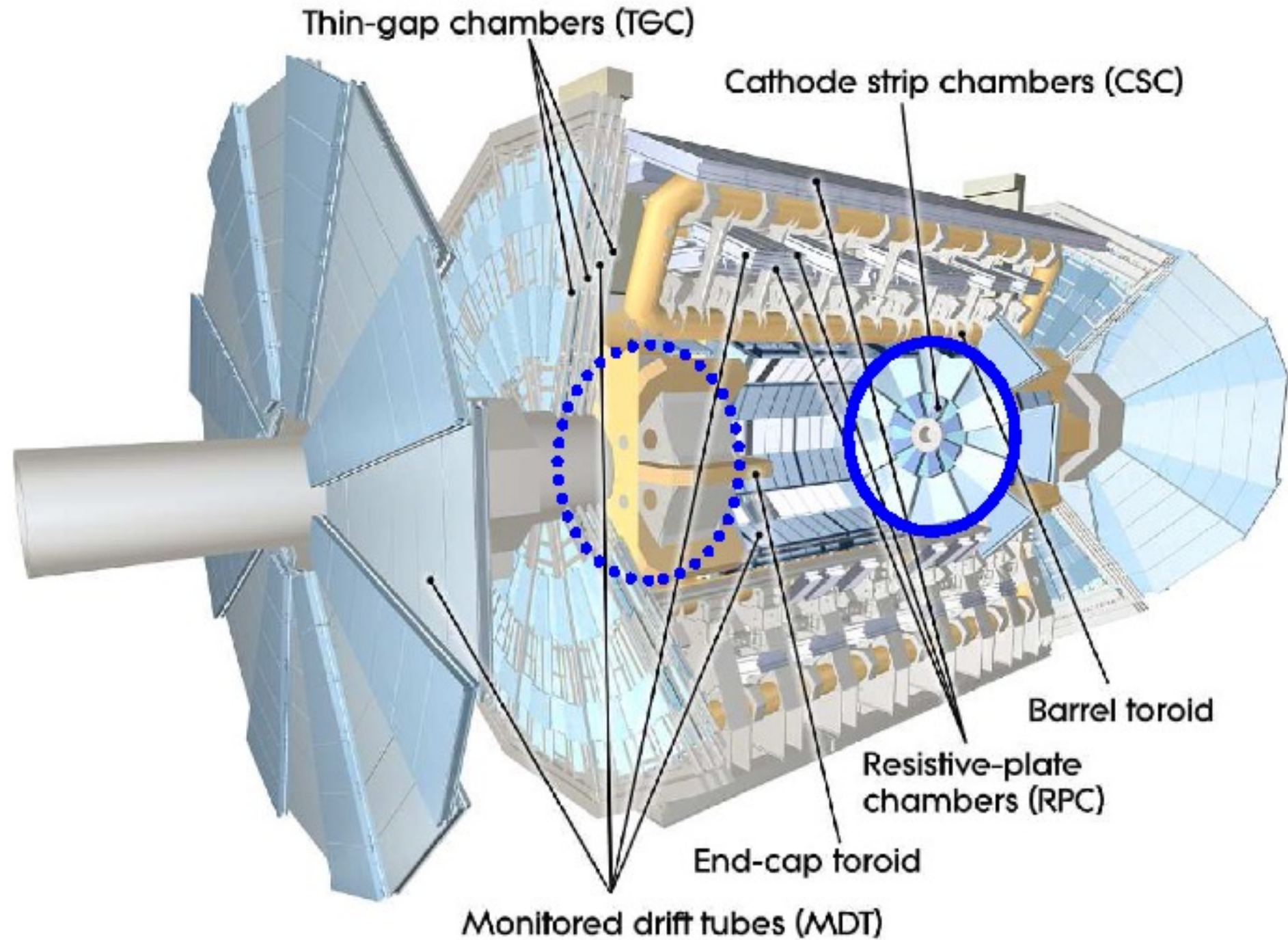

Thin-gap chambers (TGC)

Cathode strip chambers (CSC)

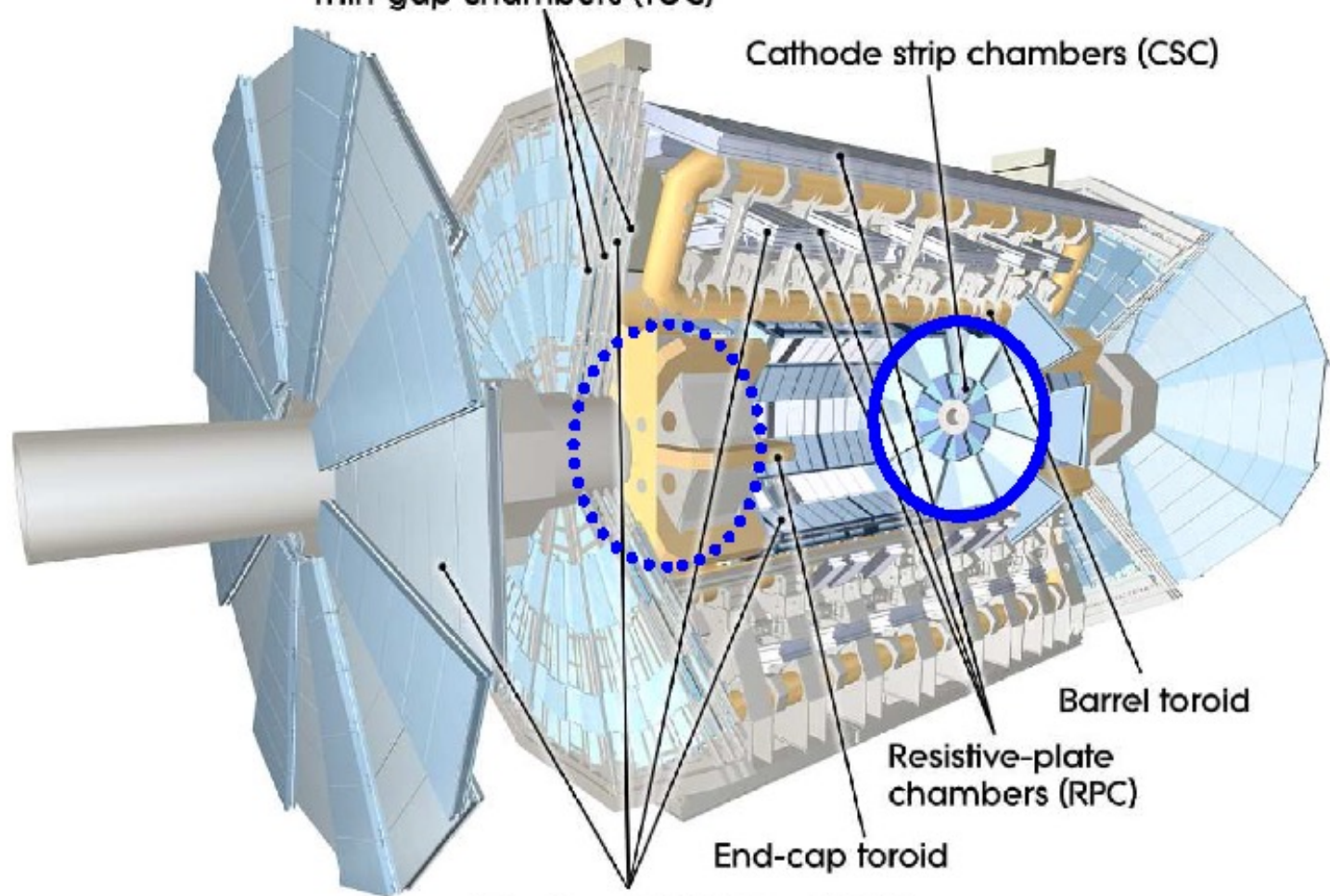

Barrel toroid

Resistive-plate chambers (RPC)

End-cap toroid

Monitored drift tubes (MDT)

