

AIDAinnova

status and achievements in RP2

P. Giacomelli (INFN Bologna)

INFN Bologna

AIDAinnova Scientific coordinator



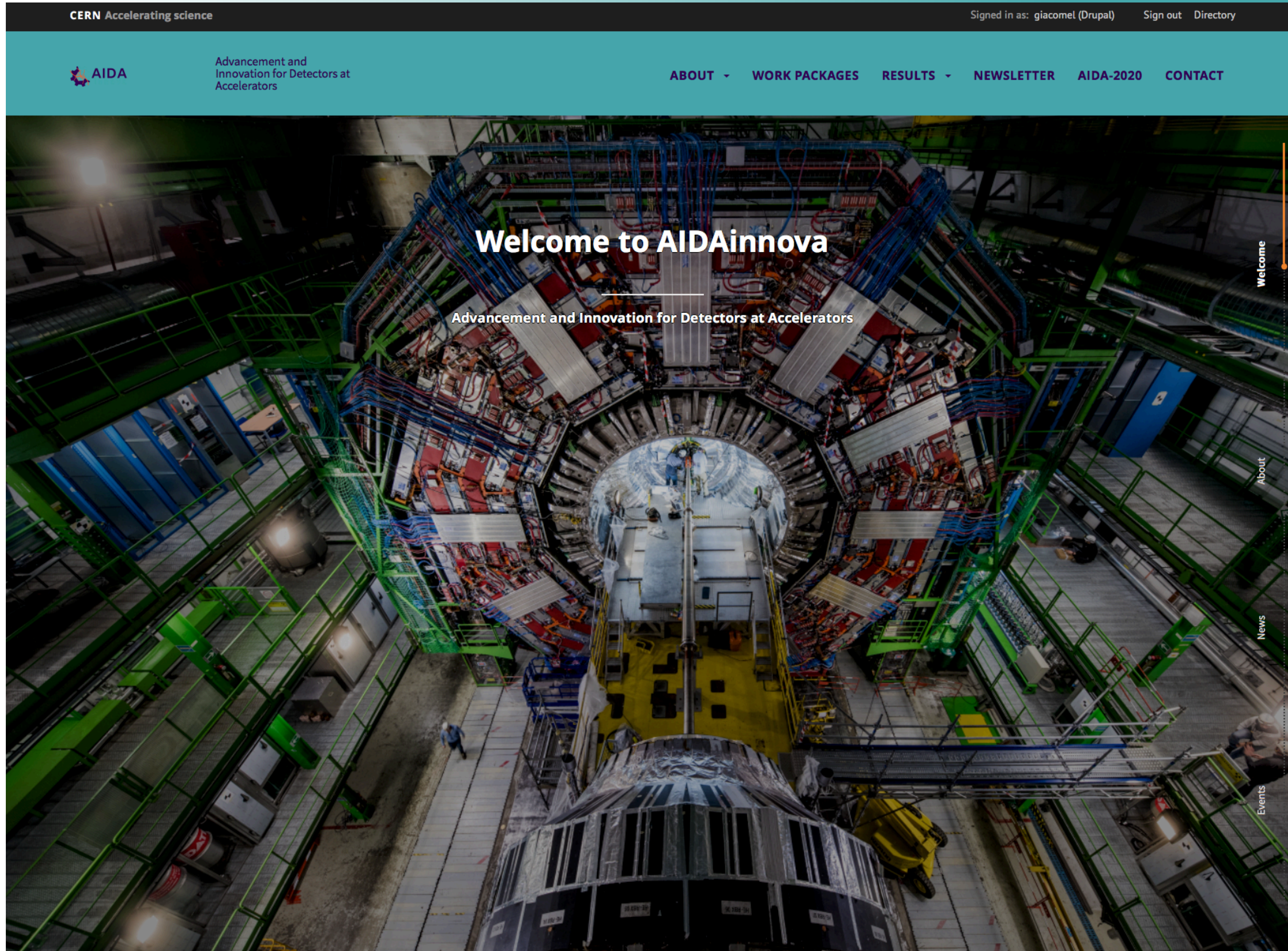

CSIC, Valencia, Spain

24-27 April 2023

- 108 participants
- Content:
 - WP meetings
 - Academic lectures
 - Hackathon
 - Plenary meeting
 - Governing Board meeting

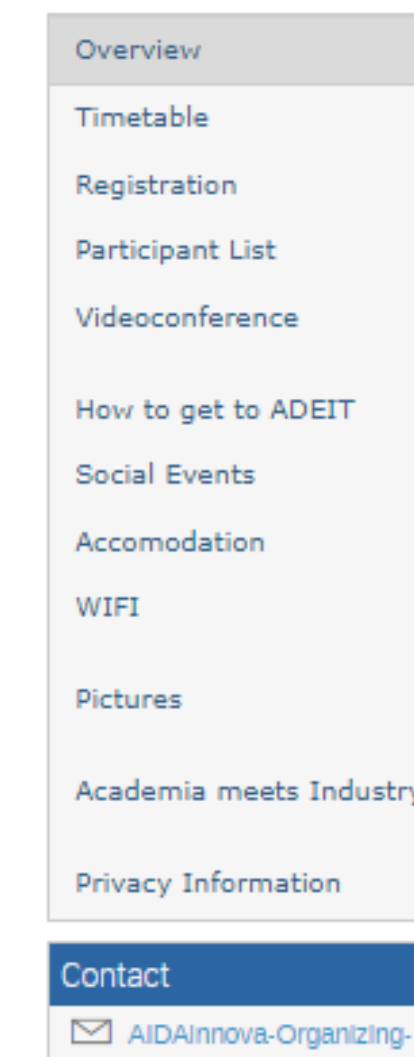
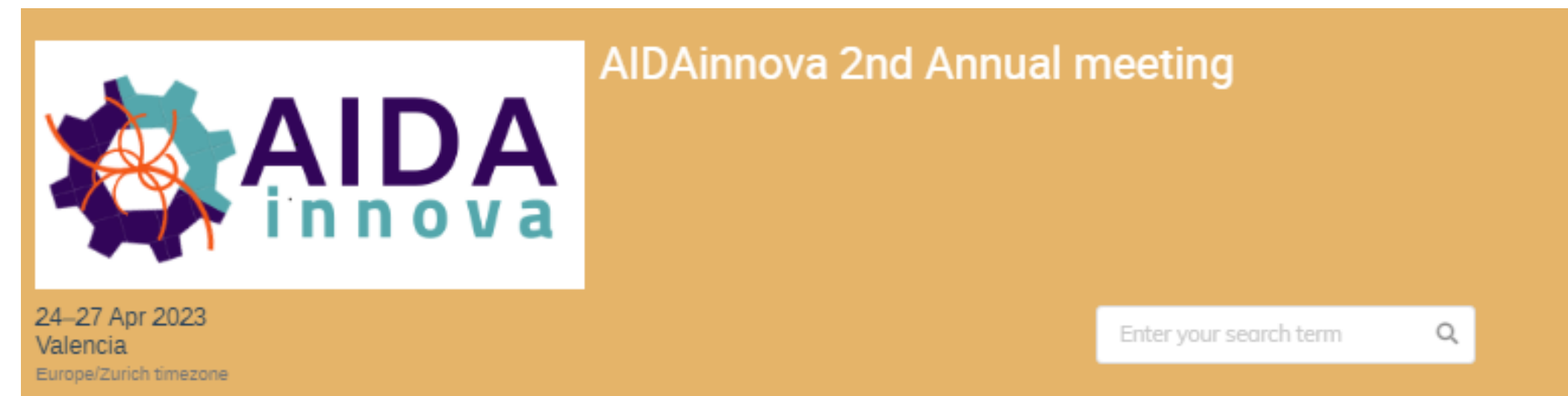

The **AIDA innova** second annual meeting will take place in ADEIT and CSIC, Valencia from **24th to 27th April 2023**. The event will assemble the **45 beneficiaries** and numerous associate partners to discuss the **scientific and technical achievements** since the 1st Annual meeting on March 2022, as well as the plans for the third year of the project.

The Second annual meeting will consist of parallel meetings of Work Packages, plenary sessions, a Steering Committee and a Governing Board meeting.



For questions or further information on the AIDA innova 2nd Annual meeting please contact the [Local Organizing Committee](#).

CSIC, Valencia, Spain
27 April 2023

- 52 participants

- Content:
 - Invited talks
 - Flash talks
 - Networking



AIDA innova - Academia meets Industry - Advanced Mechanics

27 April 2023
 ADEIT
 Europe/Paris timezone

Event description
Timetable
Registration
Participant List
Meeting Poster
How to get to ADEIT
Accommodation
Cocktail Reception
AIDA innova 2nd Annual Meeting
Support
AIDA innova-info@cem.ch

The AIDA innova Industry Academia event aims at fostering synergies between detector R&D programmes of AIDA innova members and the Industry, by creating awareness of strategic R&D topics in academia and of strategic industry needs for which industry-academia collaborations could be envisaged.

The first AIDA innova Academia meets Industry will focus on **Advanced Mechanics**, and will consist of technical talks by industry and academic partners, industrial exhibition for industrial partners and a Network Cocktail Reception.

The event will be hosted by IFIC (UV/CSIC) at ADEIT in Valencia on Thursday, 27 April 2023.



**ACADEMIA MEETS INDUSTRY
 ADVANCED MECHANICS**

THURSDAY, APRIL 27TH
 VALENCIA, SPAIN

CSIC

UV

IFIC

ADEIT

india.cem.ch/event/1443222

This project has received funding from the European Union's Horizon 2020 Research and Innovation programme under the Marie Skłodowska Curie Grant Agreement No. 101019712.

Catania, Italy

18-21 March 2024

- 90 participants

- Content:
 - WP meetings
 - Hackathon
 - Plenary meeting
 - Governing Board meeting



- Overview
- Timetable
- Registration
- Participant List
- Videoconference
- How to get to Catania
- The venue
- Accommodation in Catania
- Restaurants and local bars
- Social Events
- Pictures
- Contact
- ✉ AIDA innova-Organizing-...

The **AIDA innova** third annual meeting will take place in Hotel Principe, Catania, Italia from **18th to 21th March 2024**. The event will assemble the **45 beneficiaries** and numerous associate partners to discuss the **scientific and technical achievements** since the 2nd Annual meeting on April 2023, as well as the plans for the last year of the project.

The Second annual meeting will consist of parallel meetings of Work Packages, plenary sessions, a Steering Committee and a Governing Board meeting.



- Milestones: From M1 to M36, 48 milestones were due, 3 are still not achieved

MS n°	Milestone name	WP	Task	Planned delivery date	Status
MS8	Telescopes upgraded with ALPIDE sensor	WP3	3.2	M27 (June 2023)	Delayed
MS9	Timepix4 timing layer in telescopes	WP9	9.3	M33 (December 2023)	Delayed
MS27	Build a 0.3x0.3 m2 prototype and the read-out plane with the new structure	WP7	7.3	M36 (March 2024)	Delayed

- Deliverables: From M1 to M36, 14 milestones were due, 4 are still not achieved

Del n°	Deliverable name	WP	Task	Planned delivery date	Status
D11.1	Presentation video	WP11	11.2	M22 (January 2023)	Delayed
D3.1	Common cold box delivered	WP3	3.2	M30 (September 2023)	Delayed
D6.1	EPQ-Requirement No. 2	WP6	6.2	M30 (September 2023)	Delayed
D8.1	Demonstrator of a combined read-out system of highly granular electromagnetic and hadronic calorimeters	WP8	8.2	M36 (March 2024)	Delayed

- Full costs (EU contribution + matching funds, without indirect costs) and full PM

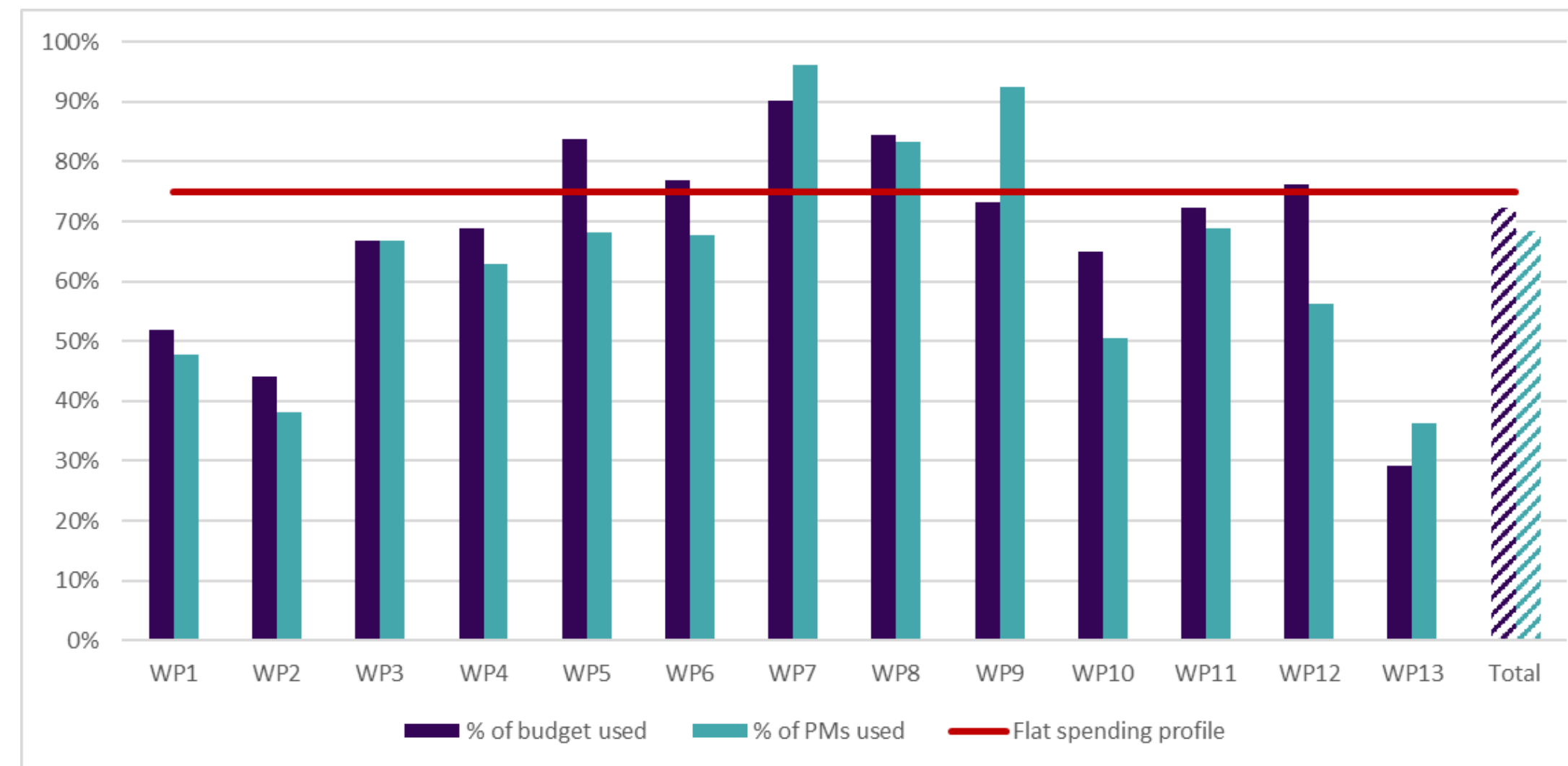

- WP1, WP2 and WP13 are significantly underspending the resources compared to a linear utilisation through time:
 - The work in WP1 and WP2 is progressing well, and all tasks, milestones and deliverables are on track. However, there is an underspending of manpower, correspondingly of budget as well, due to an over-estimation of the manpower needed to accomplish the work.
 - The slow use of resources was foreseen on WP13, as blue-sky projects were selected in second half of P1, and some selected projects needed time to be launched. Most of the resources are planned to be used during P3.

- Full costs (EU contribution + matching funds, without indirect costs) and full PM
Sorted from highest reported full costs (budget) utilisation, to lowest

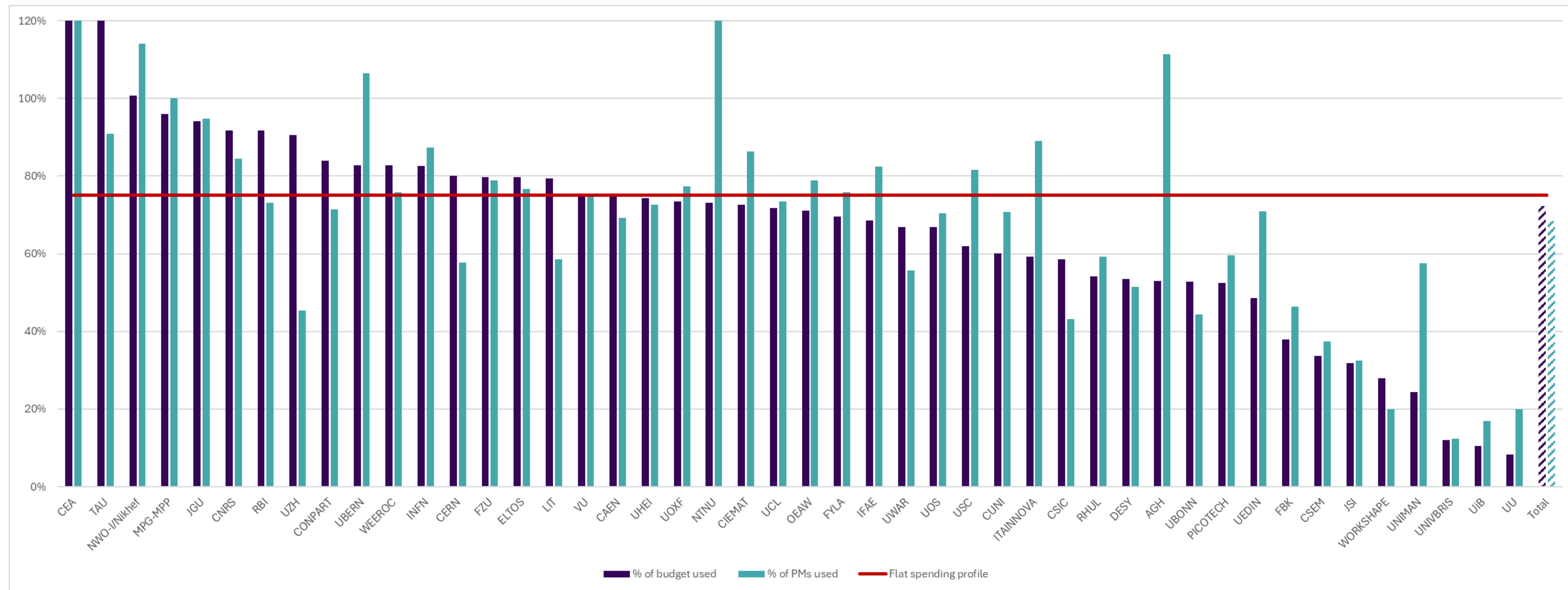

- **Total:**
 - 16.47M€ out of the total 22.77M€ (72% of the full costs used)
 - 2.4k PM out of the total 3.5k PM (68% of the full person-month used)

- Requested EU contribution (P1+P2):

In overall, 78% of the maximum EU contribution has been requested (7.81M€ out of 10M€), even if we can notice various situations from a beneficiary to another

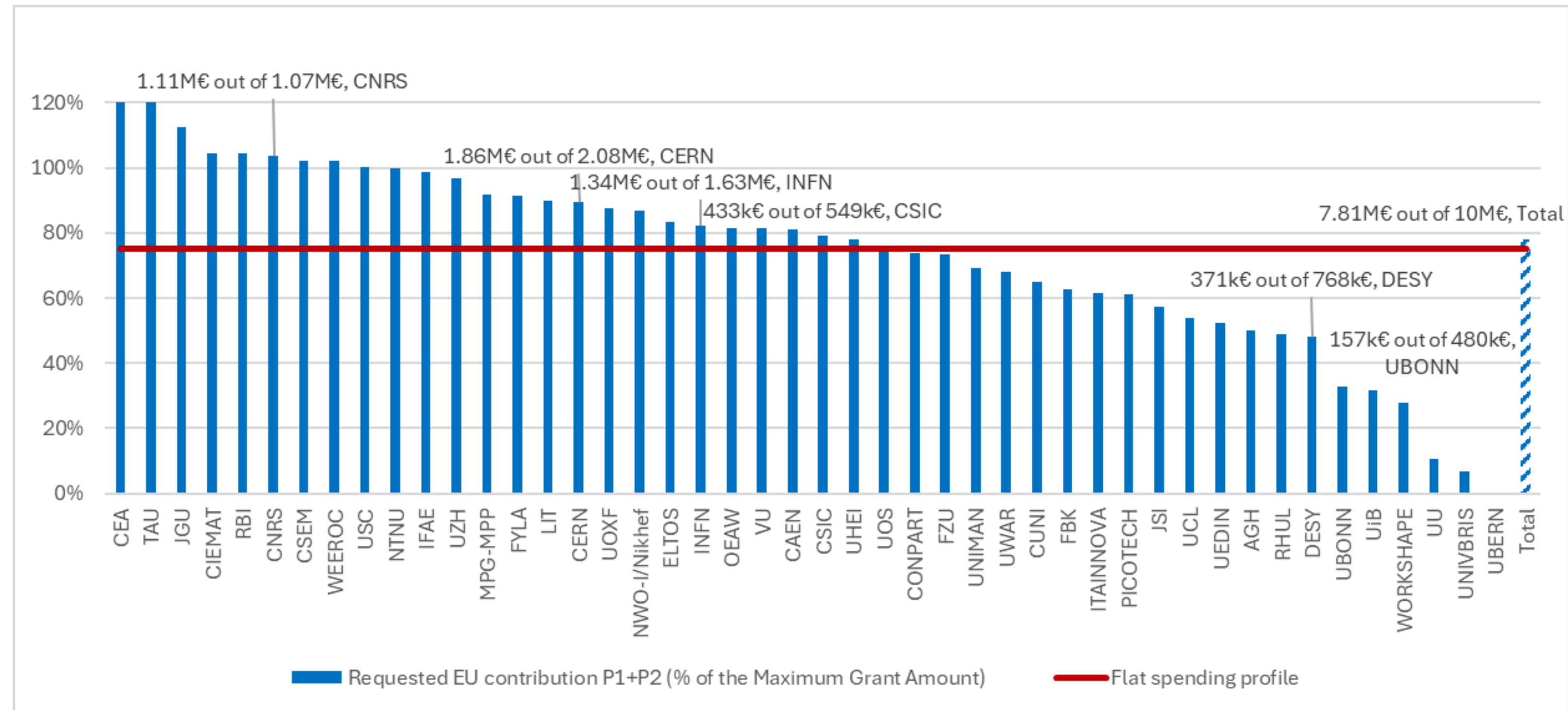

- The highlighted institutes (CNRS, CERN, INFN, CSIC, DESY and UBONN) are the main beneficiaries, cumulating 66% of the AIDAInnova maximum grant amount

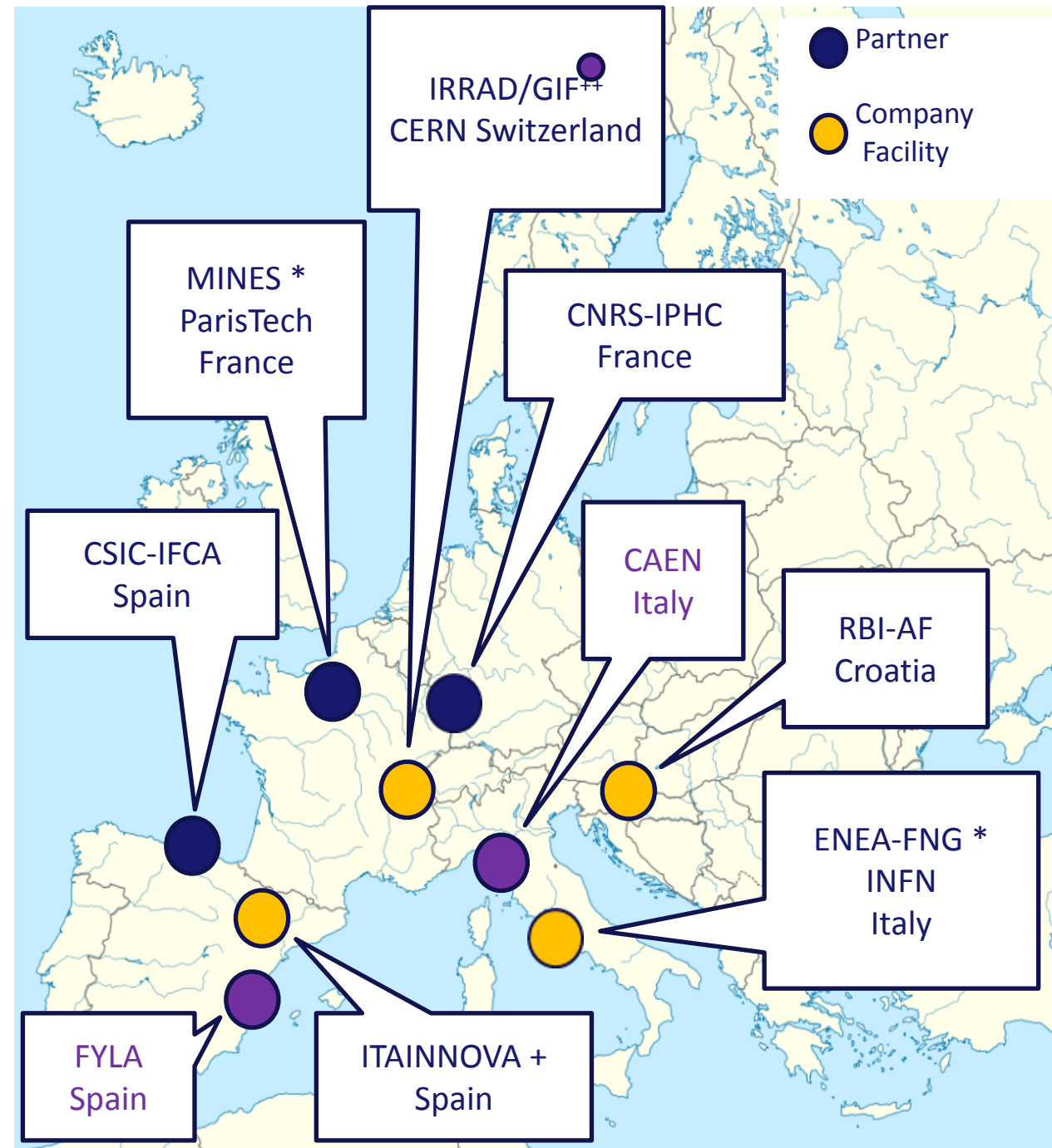

(*) Collaborating Institute
(+) RTO

New Ion microprobe at RBI

- a) Sample vacuum chamber
- b) Sample positioning system (inside the chamber)
- a) Focusing triplet
- b) Ion beam scanning system

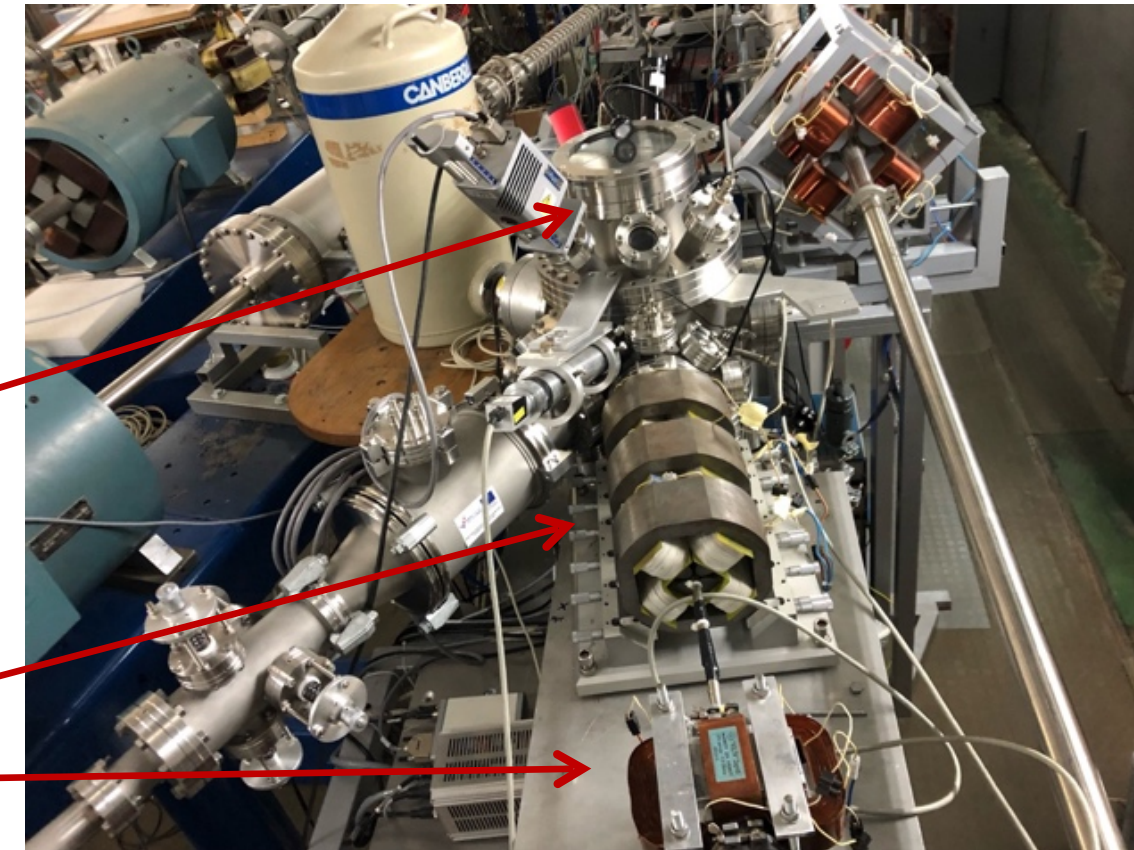

New precise motorised sample positioning to allow to move/scan the sample
 XYZ piezo stage with 29mm travel, 1nm resolution
 Related DAQ and control software upgrade
 Sample cooling capability (Liquid nitrogen or cryo)

Tools for irradiation facilities QC

Data manager for IRRAD interfaced with TREC and used also for facilities (ENEA FNG -> Fermilab ITA)
 New functionalities for traceability
 Dosimetry cross-comparison (corrections to NIEL)



R1290I, Hex, Multipurpose RAIN RFID Reader with PoE (CAEN RFID) @ CERN

Upgrade of TPA-TCT system design

Upgrade to an all-fiber system

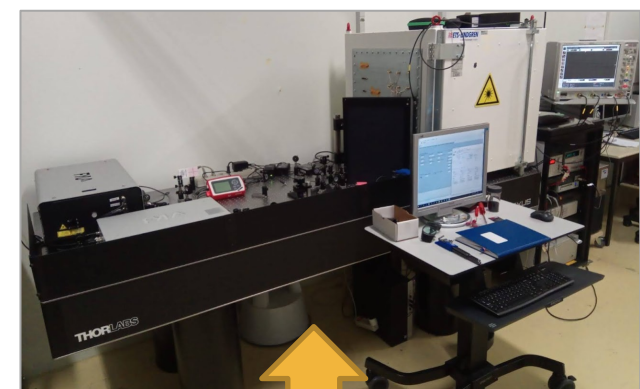

Current TPA-TCT system

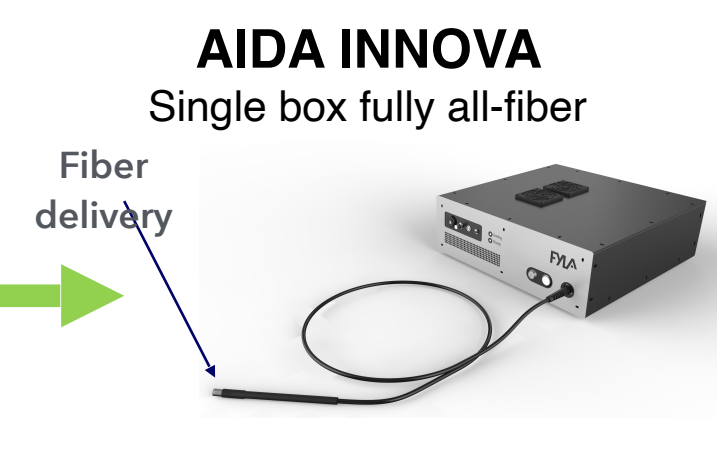
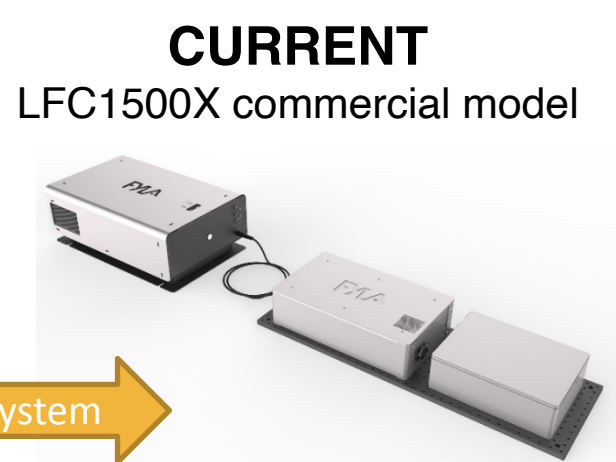

New characterization system for EMC control

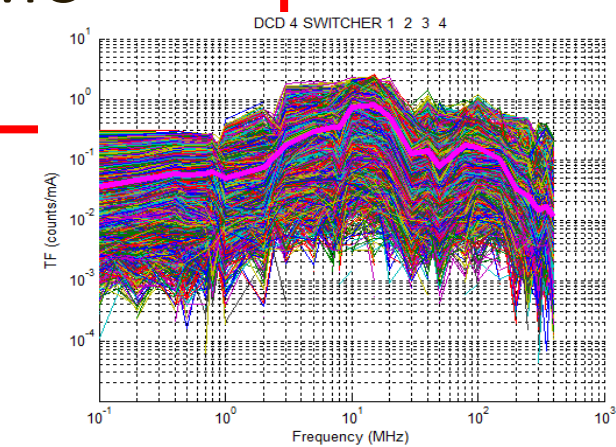

Portable noise measurement system



Processing of running productions: **LGADs**

Trench-isolated LGAD

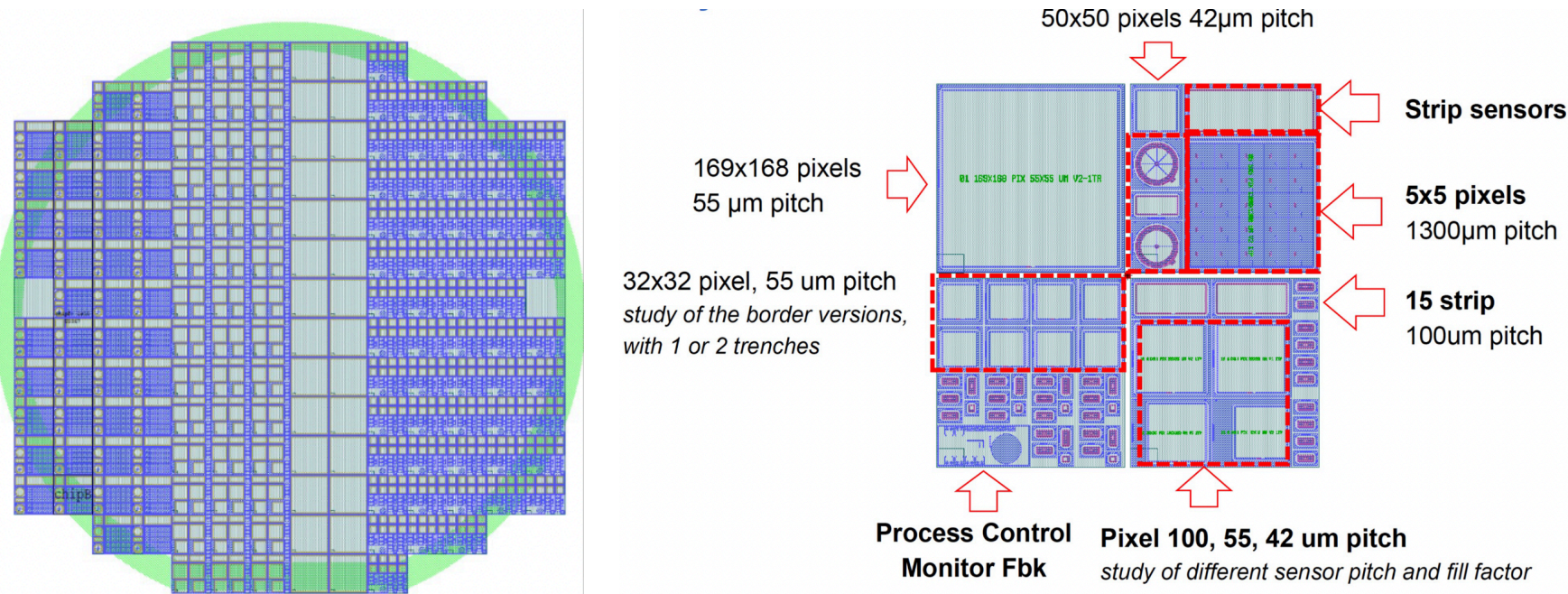

Half of the wafers carbonated with promising results

FBK

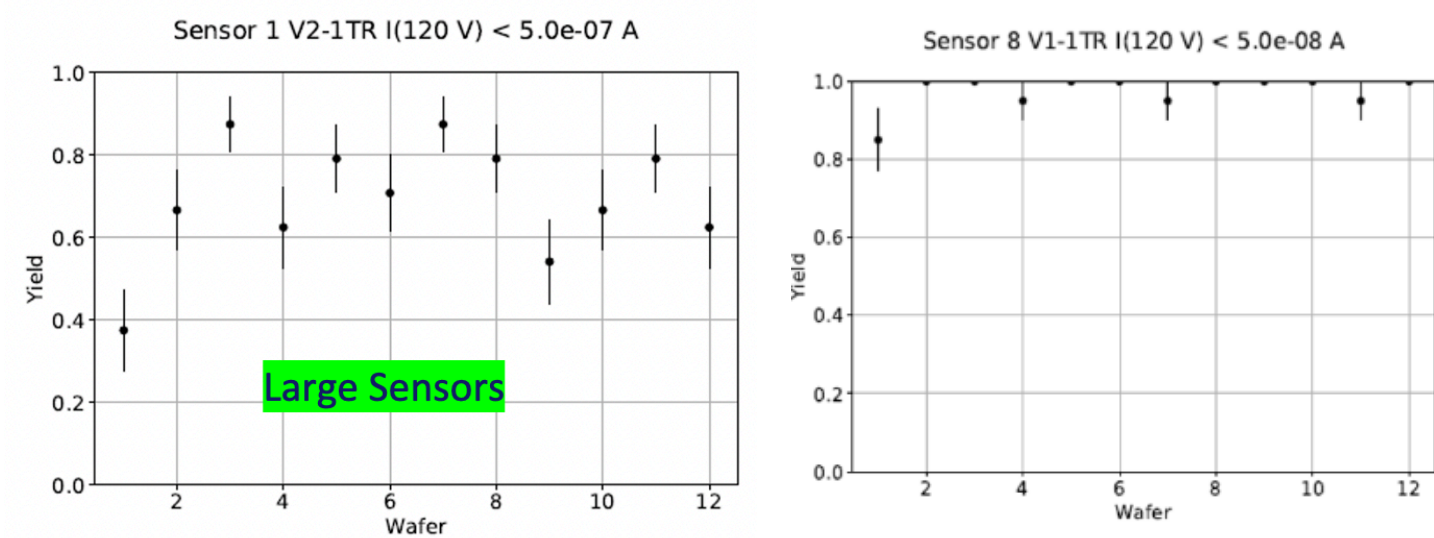

Very good yield: ~80% on large sensors, almost 100% on smaller ones

FBK

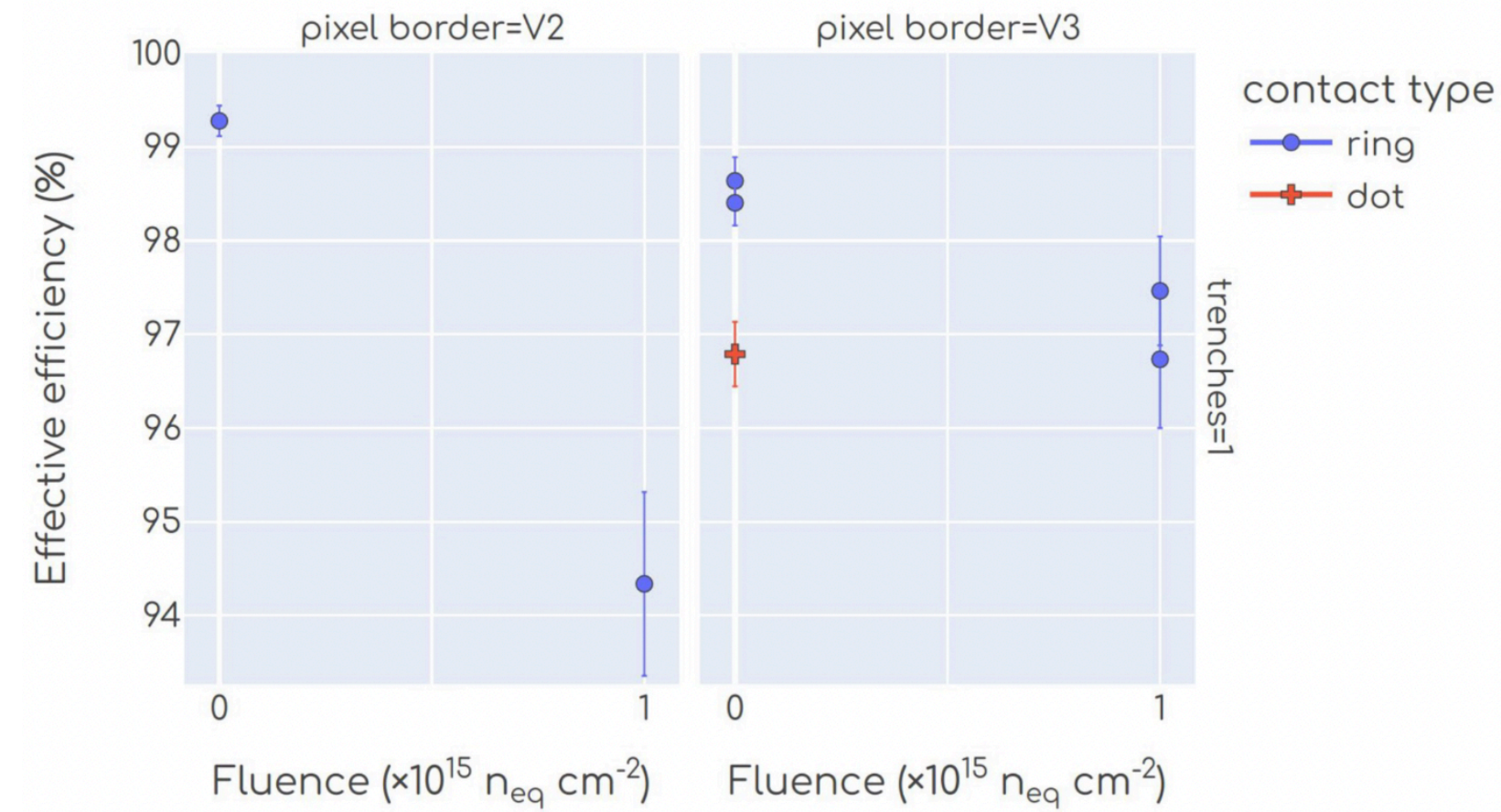

Common AIDAInnova WP6 testbeam Helped to buildup common tools for characterization of timing detectors

Good results obtained on TI LGADs Carbonated samples under test

Inverted LGAD

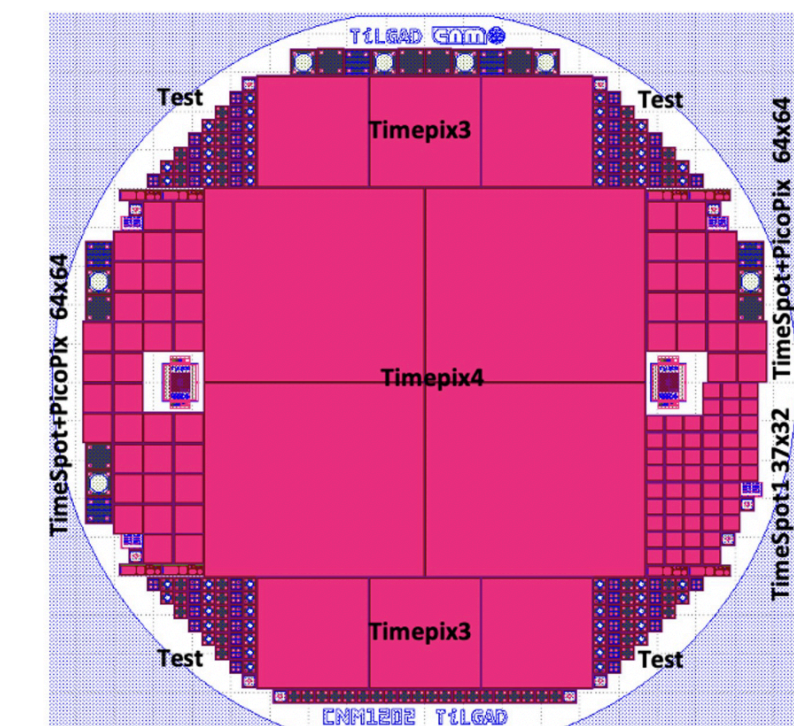
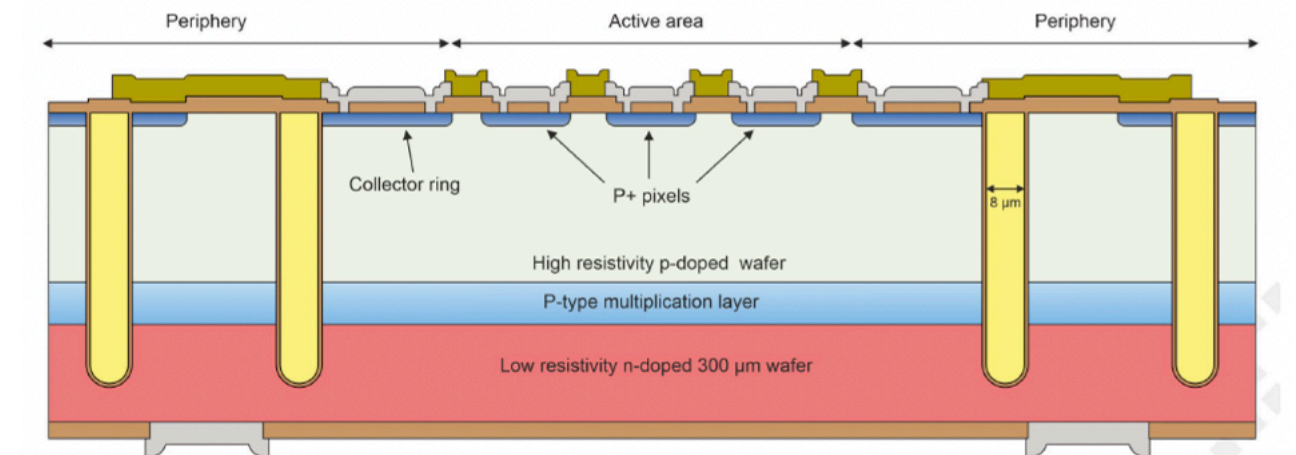

CNM

iLGAD production started on Si-Si wafers Problem identified in previous production now understood AIDAInnova production will start in a few weeks

Processing of running productions: **3D**

Timespot 3D

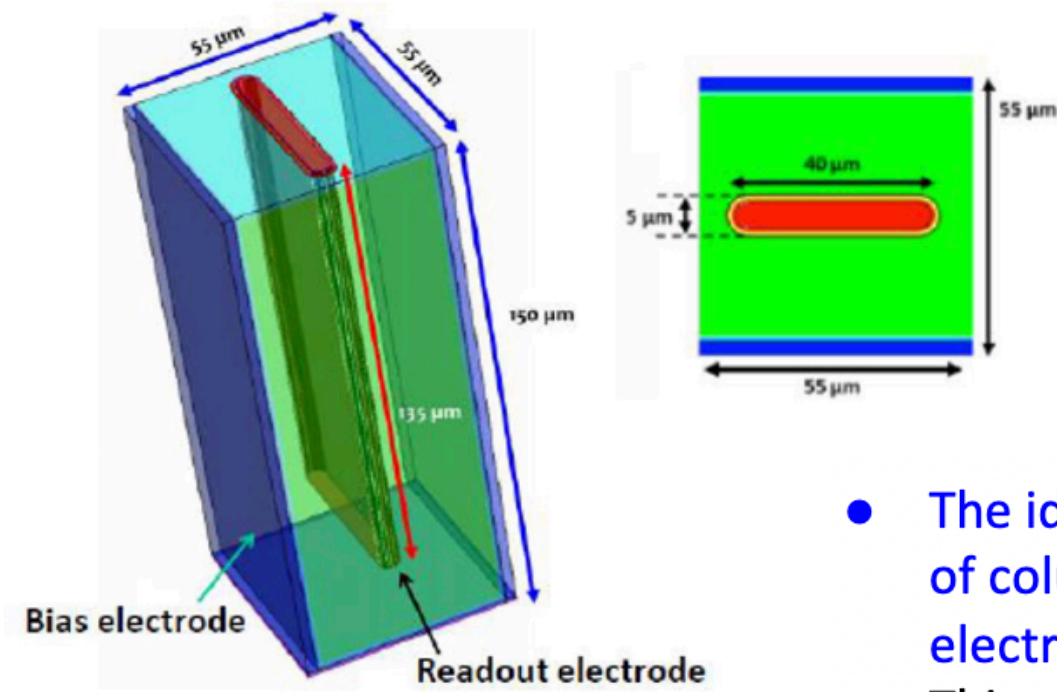

55 x 55 µm pixel
 150µm active thickness
 Radiation hardness $> 10^{17} n_{eq}/cm^2$
 Flat electrode for a more uniform field, less influence of particle position on timing

- The idea is to use a 3D based on trenches instead of columns in order to obtain a more uniform electric/weighting field between electrodes
- This reduces the dependence of timing on the impact position of particles

Trench production completed

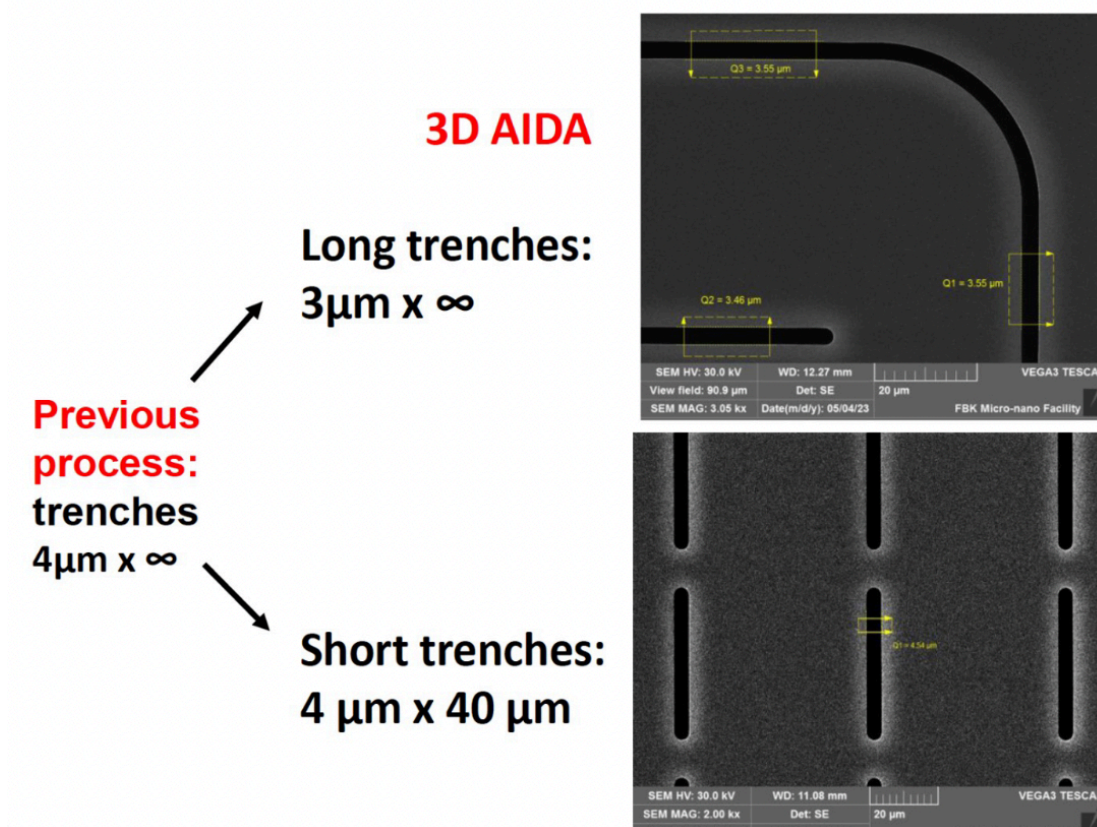

CNM

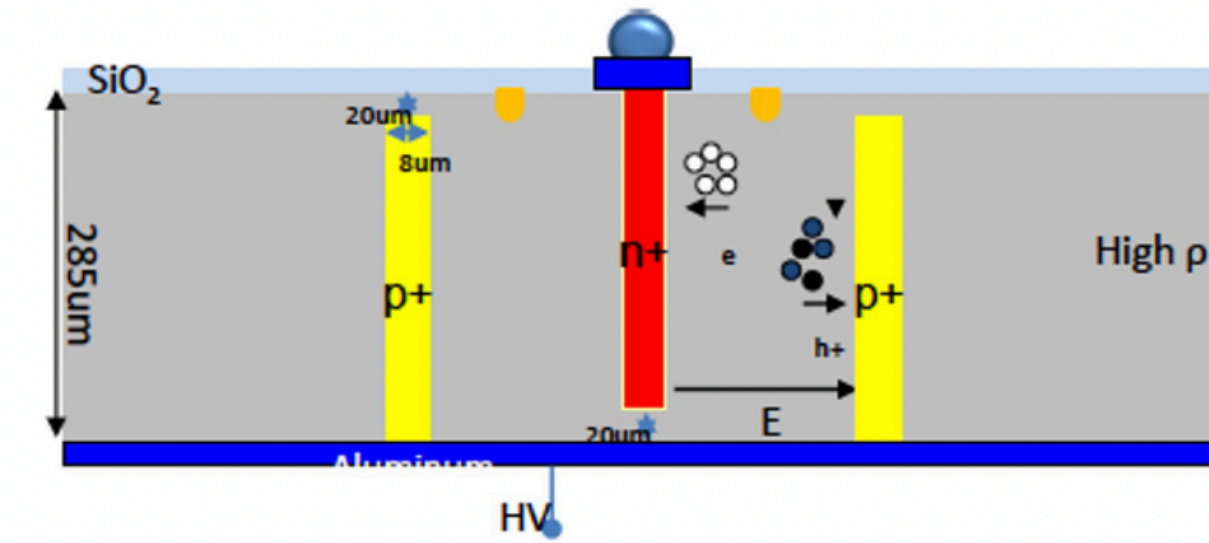

3D double-side technology
 Different sensor flavours

Prototyping 4'' production completed and under test

AIDAInnova production layout still being finalised still in 4''
 Production will start in September with approx ~1 year duration

Compatible with new timing chips being designed, PicoPix and Ignite

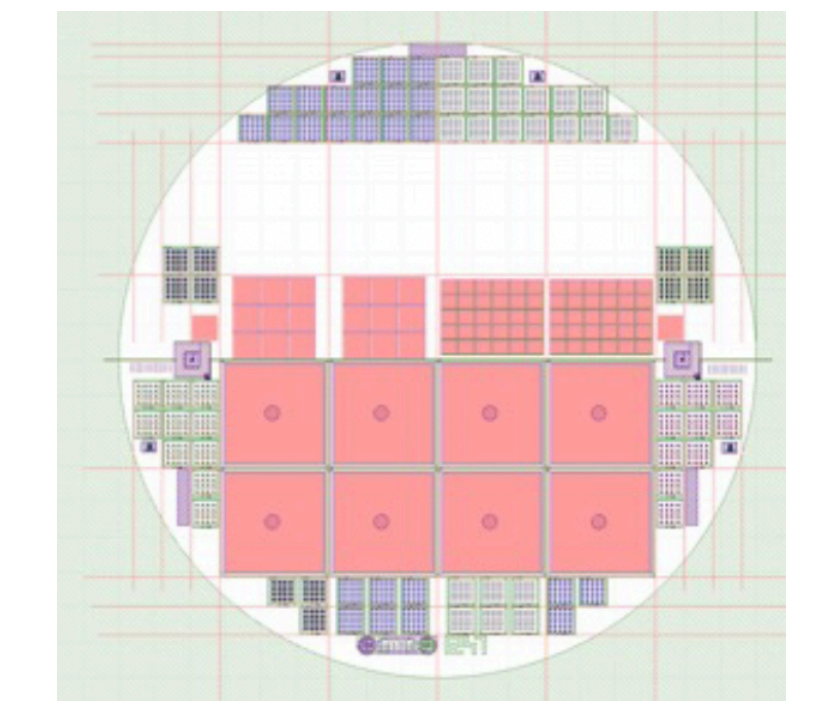
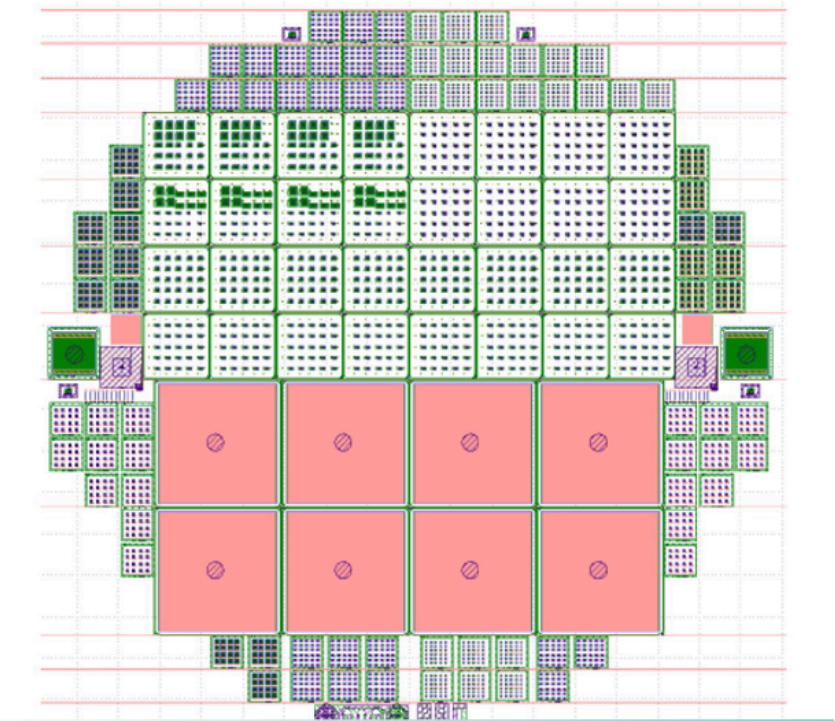

Cooling with super critical fluids

CERN / NTNU

Krypton

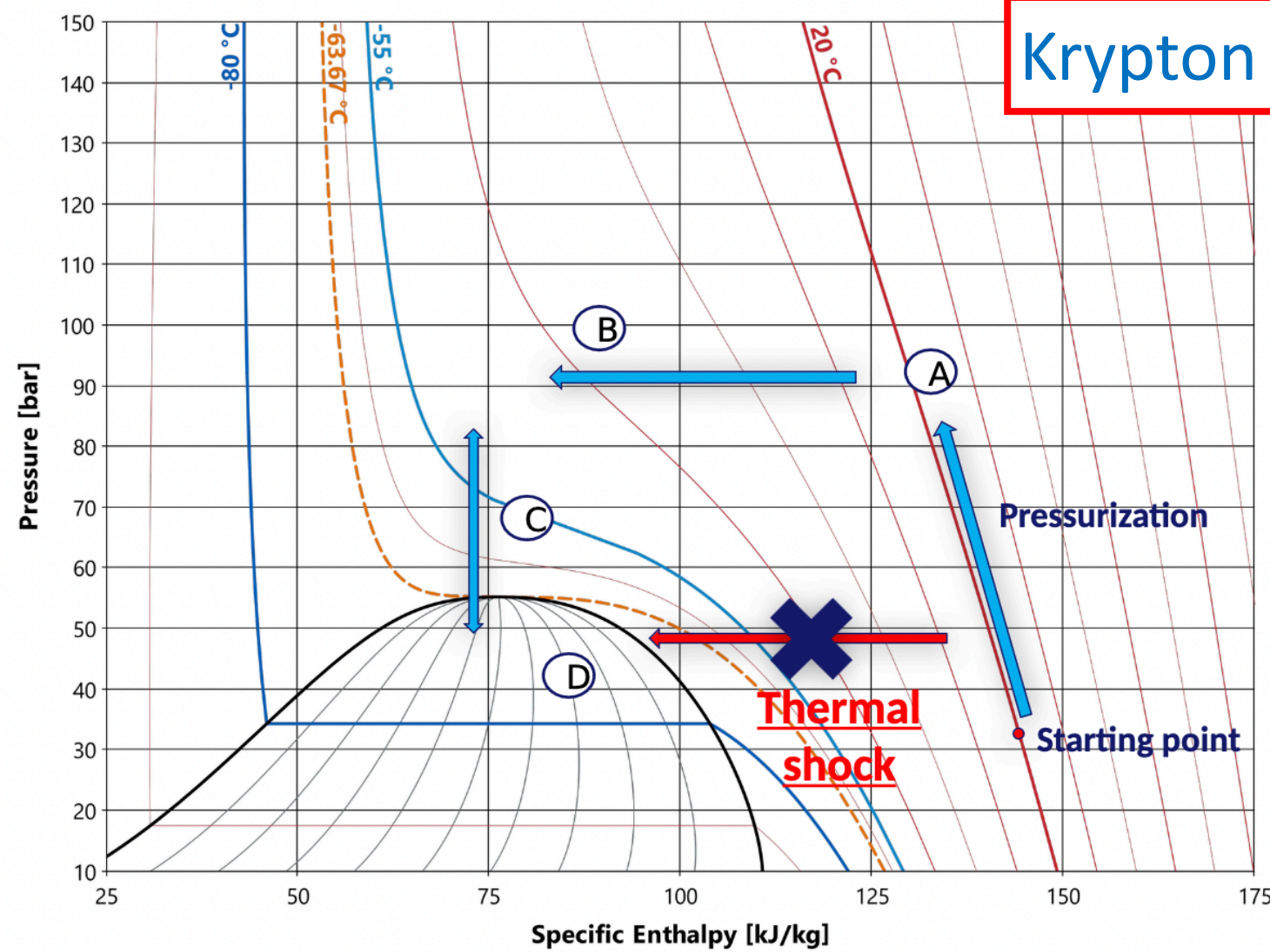

Test set-up for super-critical CO₂ and super-critical Kr at CERN by Summer 2024

Ultra-light structures with integrated cooling Carbon cold plate with embedded Kapton pipe

Purpose:

- Technology compatibility with high-pressure boiling coolants.
- Produce large surfaces cold plate (CP) for high-pressure boiling coolants.
 - i.e. evaporative CO₂ and new coolants (Krypton, ...)

3D-printed structures with integrated cooling AM Ceramic & Metal cold plates

Purpose:

- Generation of new standards to produce micro-structured cold plates produced by additive manufacturing, (ultra-thin wall).

Cold plates

- **Pipe length: 85 mm**
- **Pipe hole: 0.44 mm**

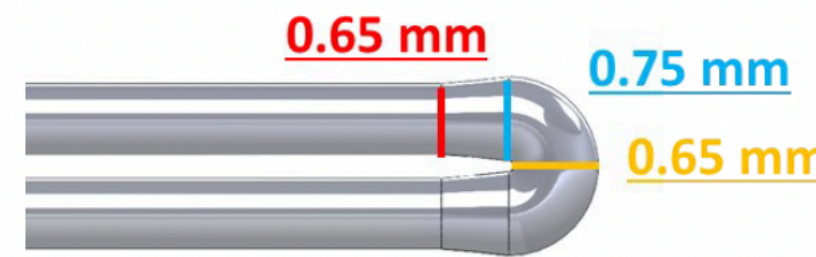

Ceramics
LITHOZ

3D integrated cooling circuits

CERN



Light structures

704 mm length truss for Belle 2 VTX upgrade
Total weight 5.8g, max sag 3-400um

INFN Pisa



Characterization of mechanical response

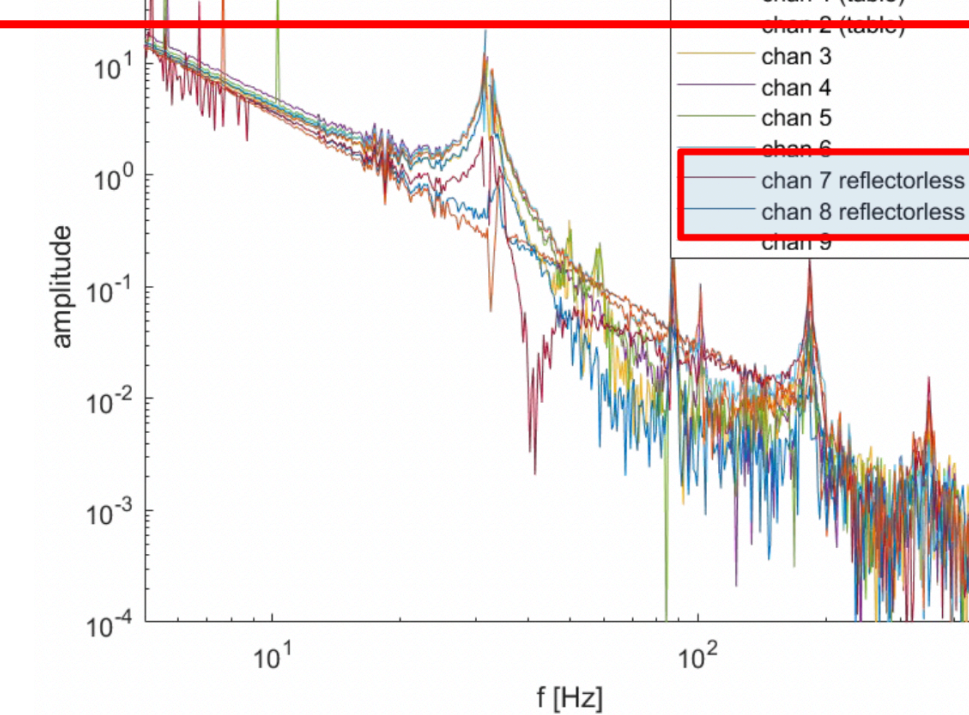

Oxford

Explorative design of chip in 28 nm

- Process qualification
- Architecture studies
- Evaluation of single event upsets
- Technology qualification
- Investigation of radiation effects

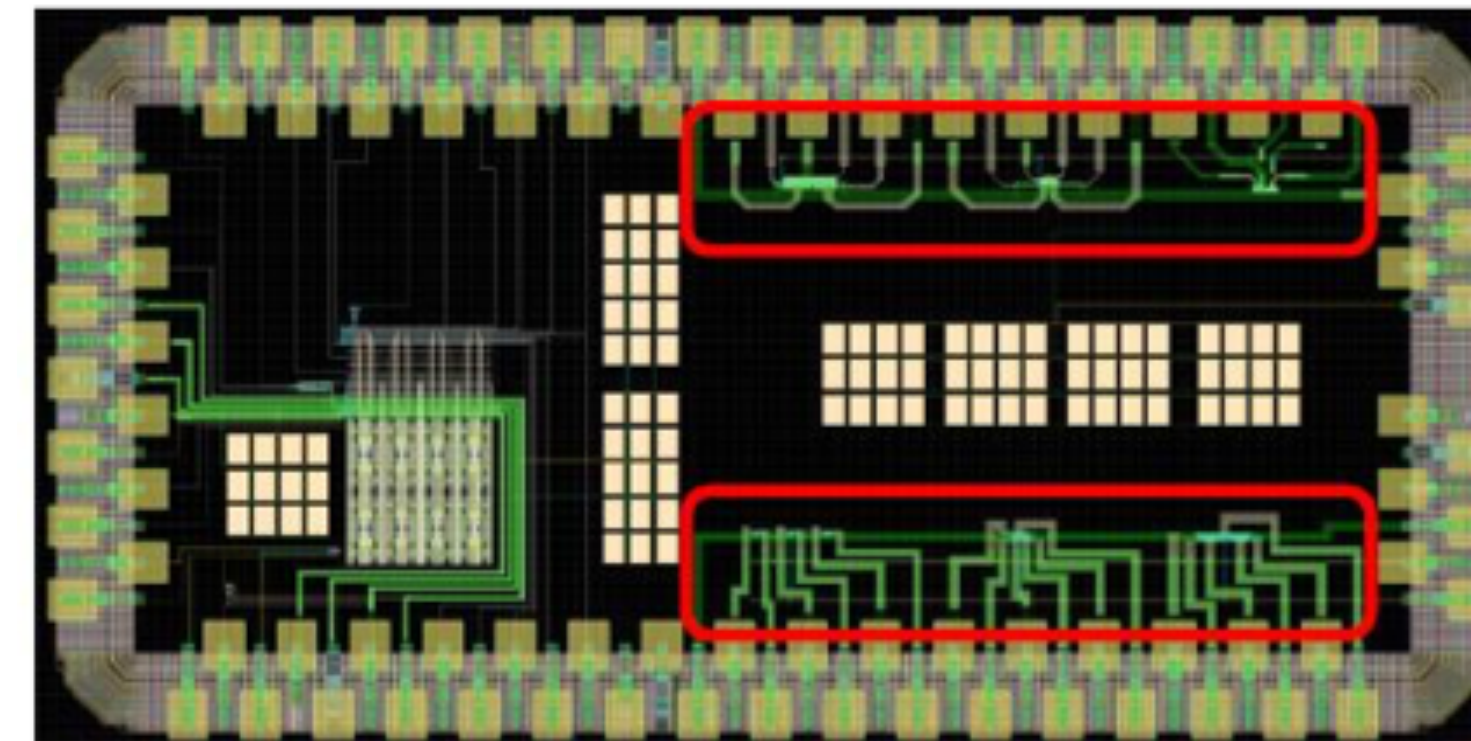
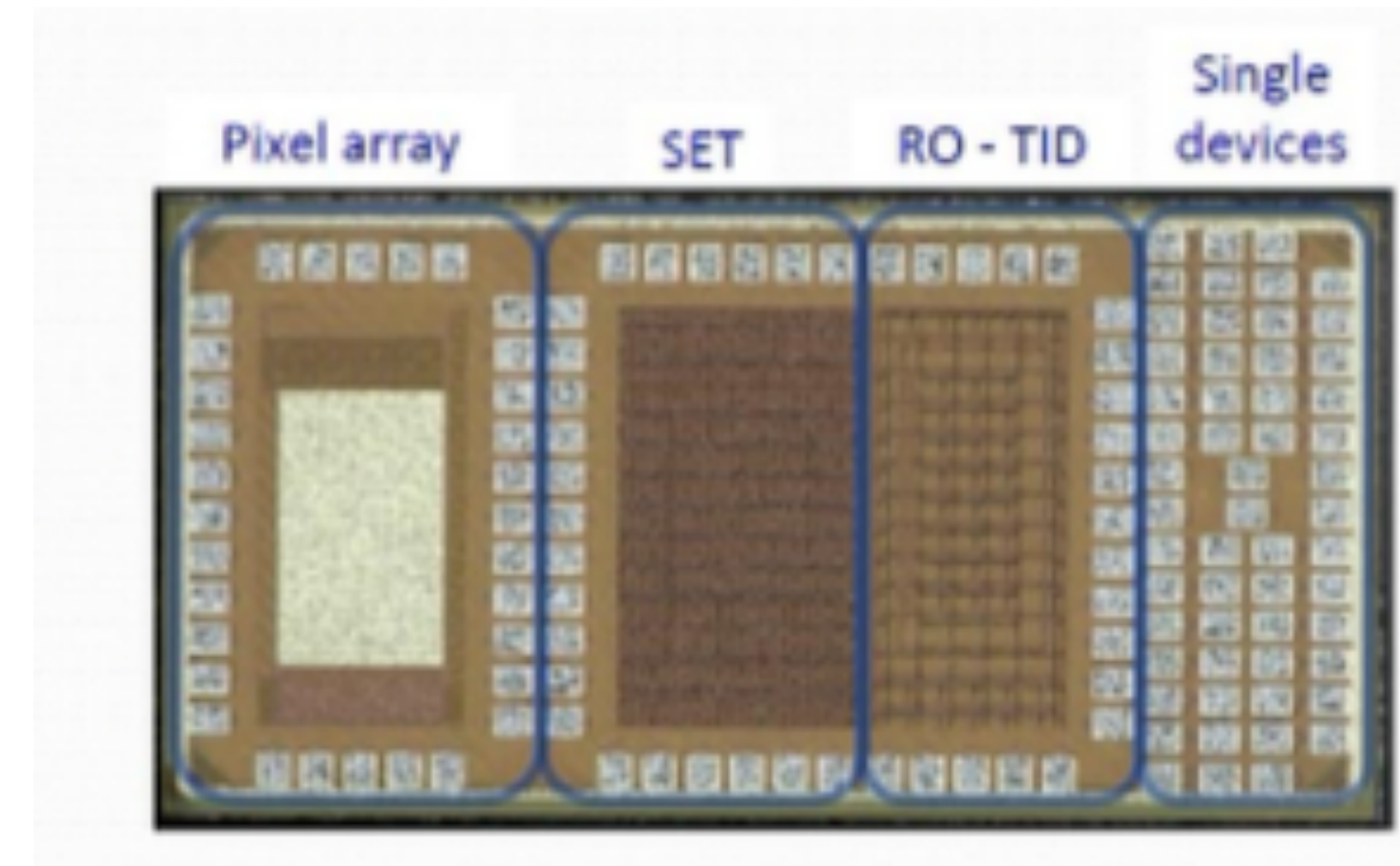
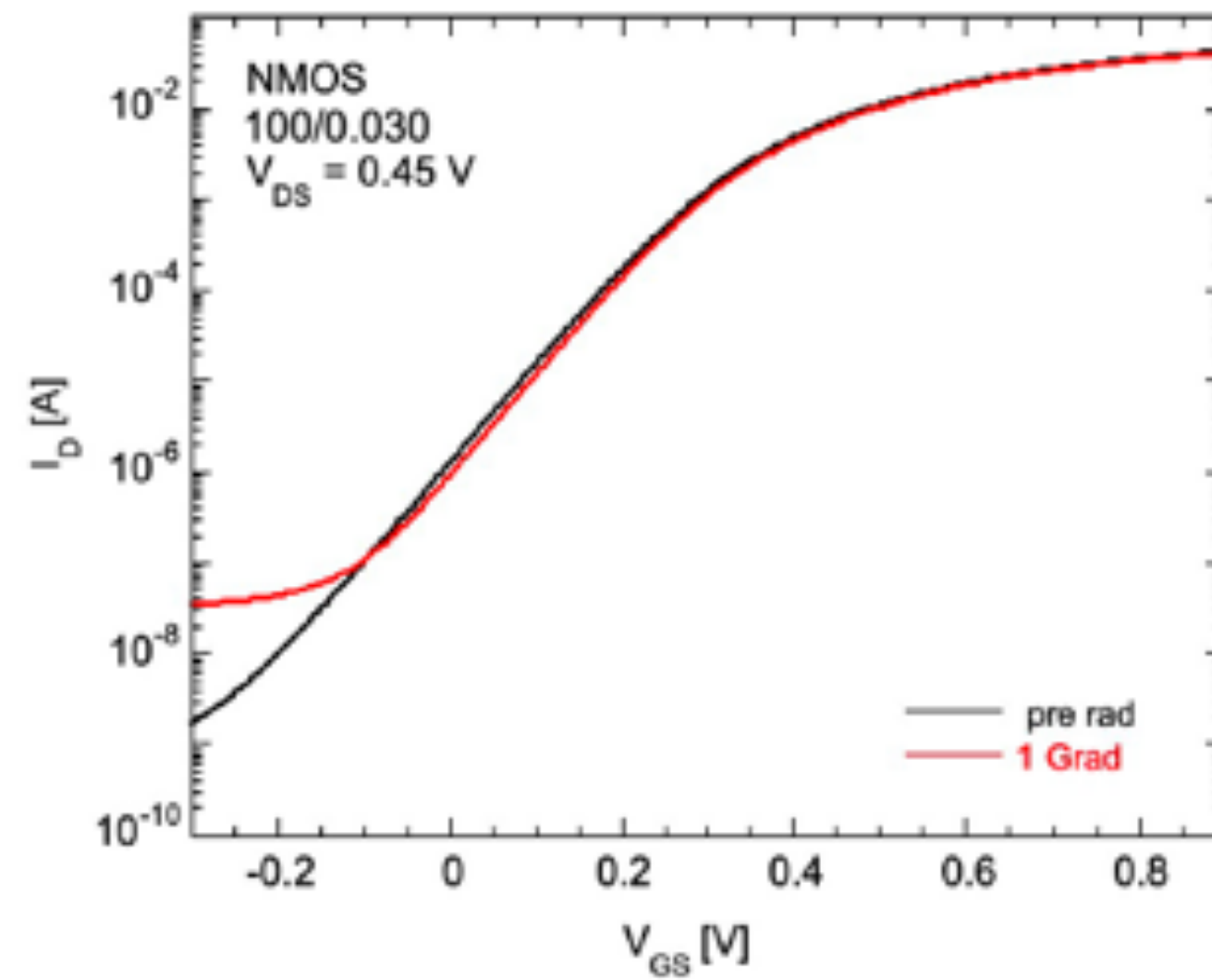

- Production of a demonstrator for the **Silicon Electron Multiplier** concept
- 3 batches to optimise the process have revealed challenges

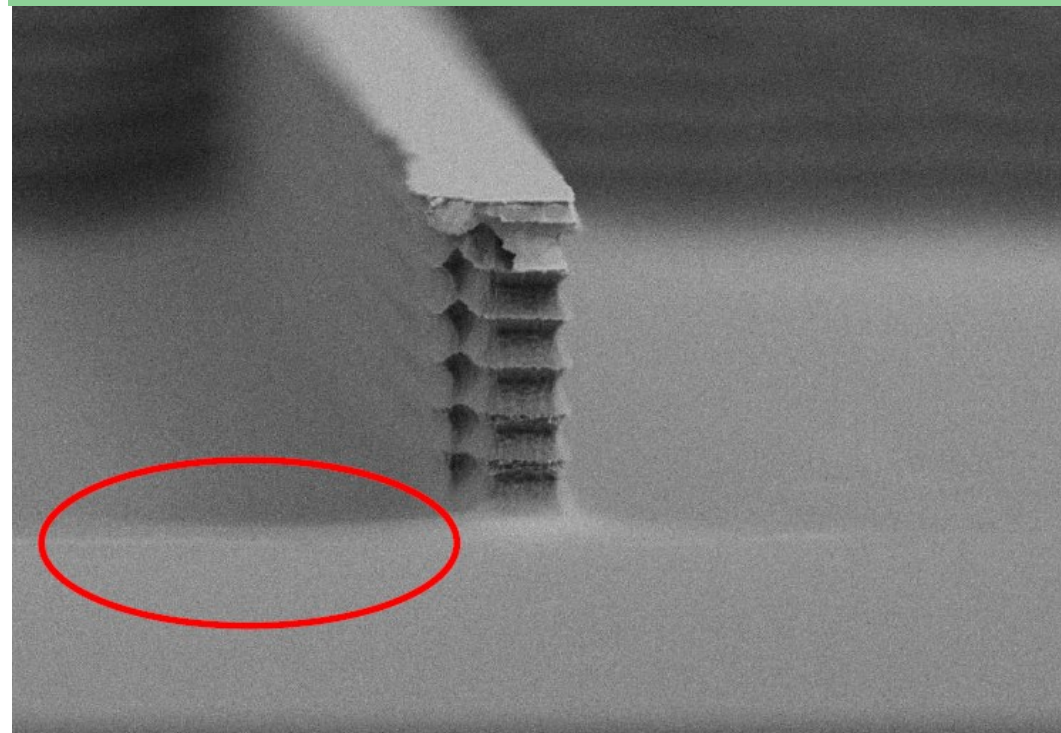

- Looking at **Metal assisted etching** with CERN and PSI (AdEM 22 (2020) 2000258)
- The process is cheap and has a high aspect ratio, but never been used in an active device

- **eXFlu-innova** : Thin Silicon Sensors for Extreme Fluences
- Compensated LGAD fabricated
- Measurements of the doped sensors and comparison with the simulation.

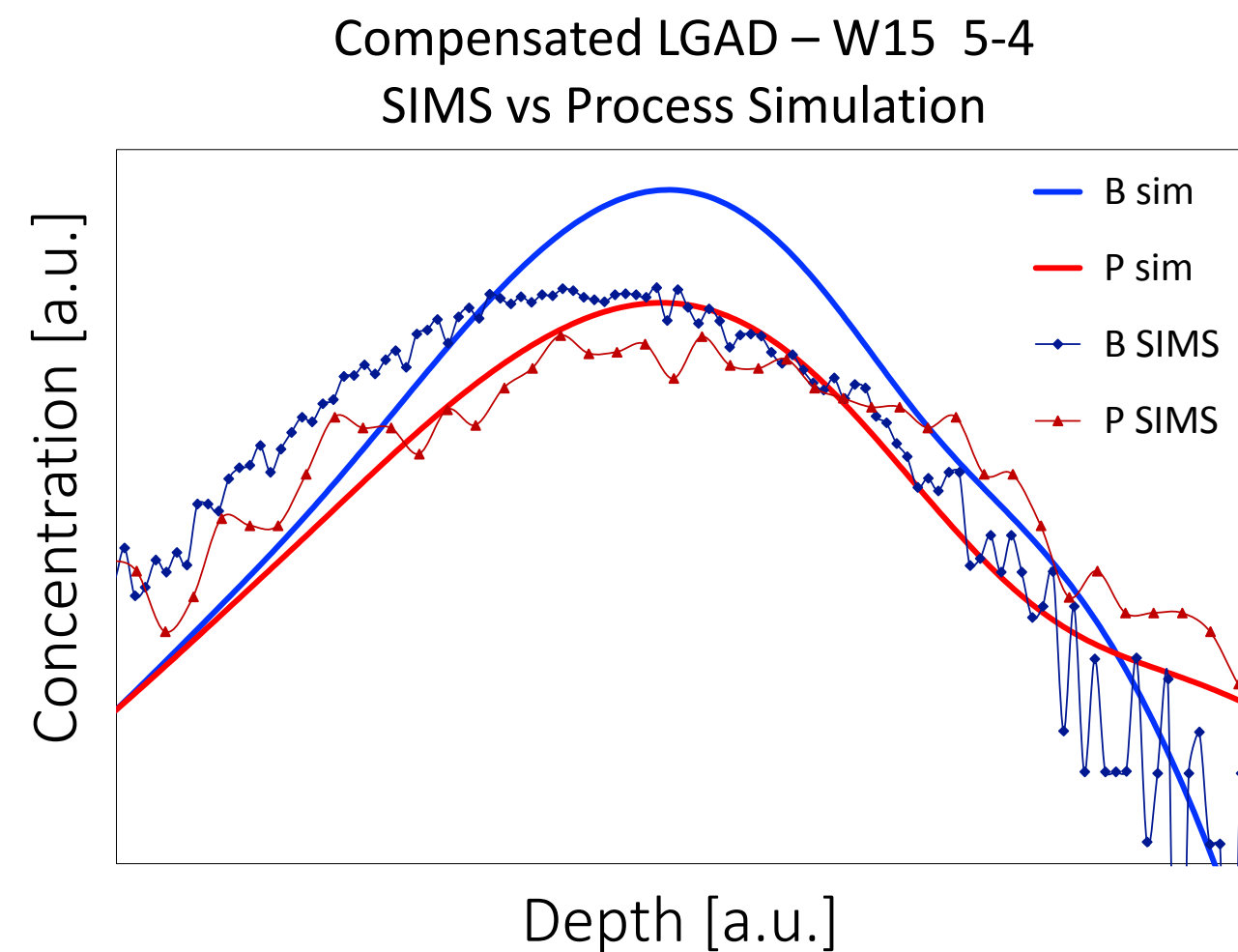

- ERC Consolidator Grant awarded for developing compensated LGAD sensors

- **Nanocal**: Development of fine-sampling calorimeters with nanocomposite scintillating materials

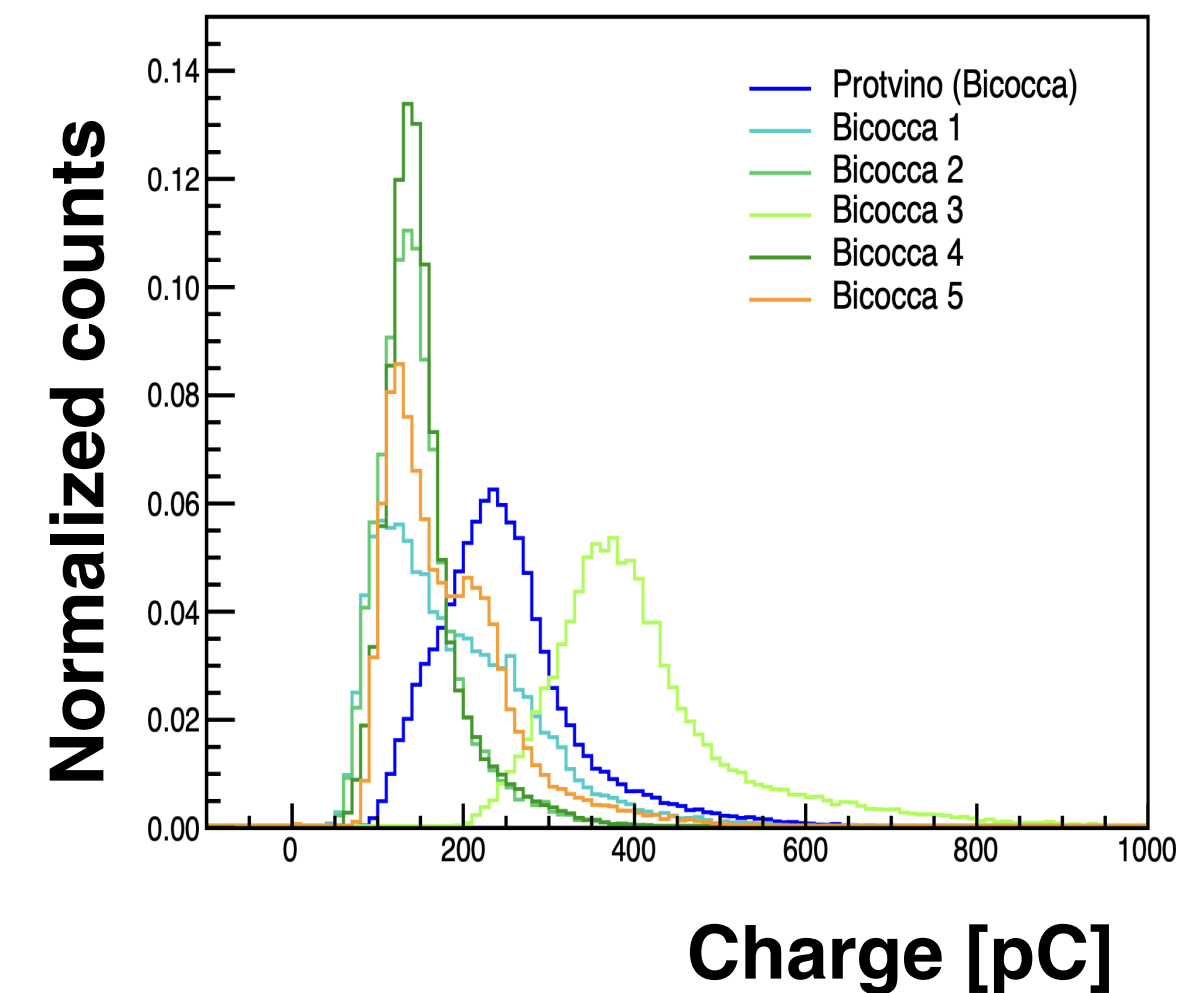

Prototypes tested in Frascati with 450 MeV e⁻ (11, 2023)

- Bicocca 4, 5: CsPbBr₃:Yb in PVT ~50% ILY of ref. sample **first nanocomposites with good mip response**

- Project: WADAPT Wireless Data Transfer for High-Energy Physics Applications



- Development of SK202 boards (employing ST-60 GHz transceiver chip)

Board outlook:

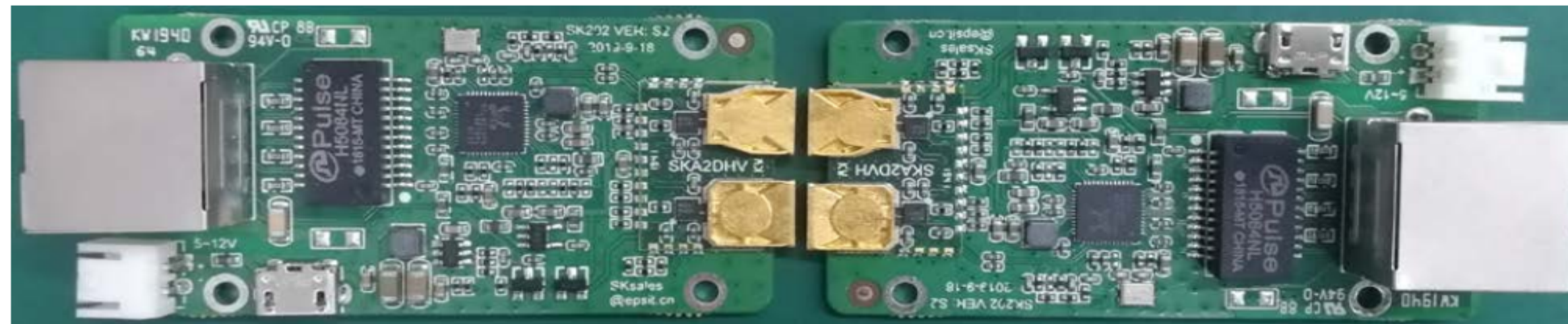

- The SK202 boards don't communicate at distances > 5 cm.
- Making a prototype with Low Noise Amplifier integrated between the 60 GHz transceiver chip and the antenna/antenna array.

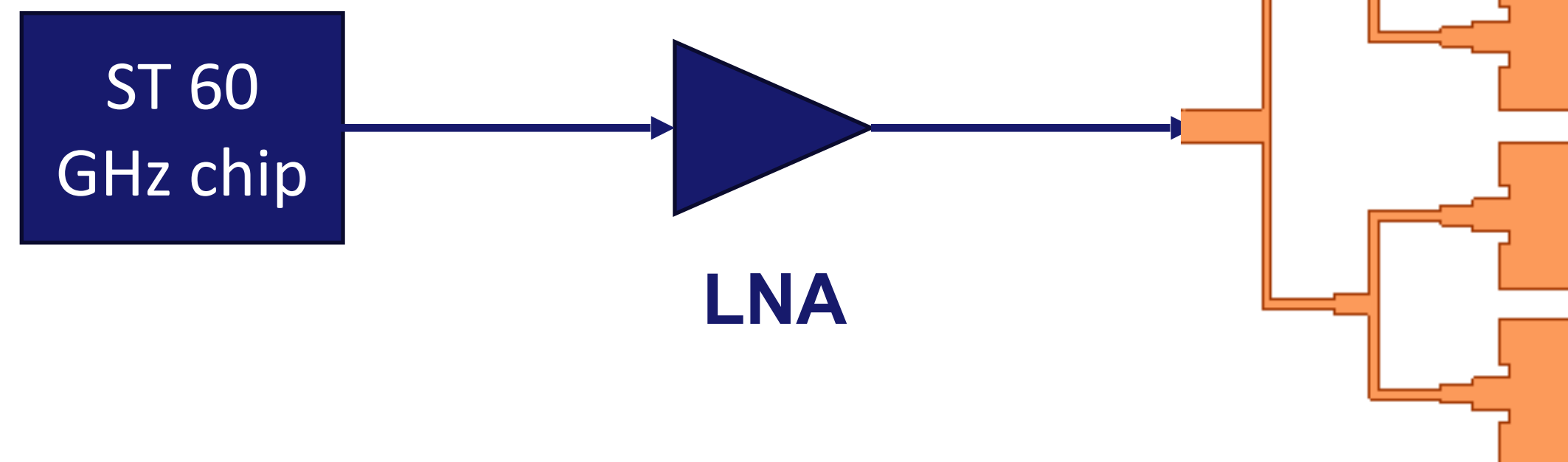

- AIDAinnova started on April 1st, 2021 a time still heavily affected by COVID
 - Difficulty of finding and buying materials, tools and equipment
 - Difficulty of employing new personnel and researchers
- Many tasks of the project effectively started after several weeks from the beginning of the project as the COVID pandemic finally started to decrease and activities could ramp up
 - These tasks could not benefit from the full 48 months duration of the project
 - In most cases we managed to get back up to speed and most deliverables will be met, but some tasks and WPs would definitely benefit from a possible extension, of the order of 6 month at no extra cost.

- WP3
 - Deliverable, “D3.2 New TLU produced” (in Task 3.3), would benefit from an extension as it would reduce the risk of this not being delivered within the current project timeframe. This has been delayed as relevant expertise left the respective institute, and hence project, as they moved jobs and it took time to hire new and appropriate engineering personnel. This and other progress was also hampered by the situation with Covid-19
 - We expected work on upgrading the beam telescopes, Tasks 3.2 and 3.3, to be completed on time. However, an extension of the project would allow more exploitation of the newly-developed systems and so increase and enhance the project’s scientific output.

- WP4
 - D4.1: during November 2024 the RBI-AF will start moving to a new building which is now under construction. The whole transfer will last at least 6 months - possibly more. RBI also procured new 5 MV Tandem that will be delivered in summer 2025. The AIDAinnova extension will allow several additional months to transfer the respective microbeam beam lines and reinstall in the new building.
 - D4.2: the reference NIEL structures are being manufactured and they will be ready to meet the deliverable. However, an AIDAinnova extension will allow also to perform first irradiation experiments with them and evaluate their results.
 - D4.3: one of the scopes of this deliverable (validate the deployment of the CERN Data Manager software tool (IDM) in facilities outside CERN) has been moved from the ENEA-FNG facility to FNAL-ITA one during the course of the project. While the software tool will be deployed on time and tested at FNAL-ITA, the AIDAinnova extension will also allow to test at FNAL the same innovate traceability tools (CAEN RadHAND tool and DigiWaste platform) which were already tested and integrated with IDM at CERN (see MS14).
 - D4.5: the EMC test campaigns at the irradiation centre (Strasbourg) are scheduled for the end of the year 2024. An AIDAinnova extension would allow us ample time to analyse the data and plan a second test campaign based on the improvements identified in the initial tests. Moreover, this extension would provide a valuable safety margin, ensuring we have enough time to repeat any tests if the initial ones encounter issues.

- WP5

- The WP5 activities follow two main lines, the development of high granularity and radiation hard devices. In the first line, an ambitious DMAPS development has suffered a delay related to the inherently unknown scientific exploration, this resulted in a second production of DMAPS with gain. To complete the evaluation of the performance of the high-granularity DMAPS developed in this line (deliverable D5.2) an extension of the support from the AIDAinnova project of about 6 months is needed. In the second line, the development of MPW-RD50 devices has been impacted by Covid in the initial stage and there is a very high risk that the final milestone MS21 is not met. An extension of the project will allow the group to properly study the performance of the latest MPW-RD50 prototypes that have been recently fabricated before and after irradiation and in beam tests.
- The first OBELIX sensor dedicated to Belle II, will only come back from fabrication in Q1-2025.
- The next engineering runs ER2 in TPSCo 65 nm is also delayed and return from fab are more Q2-2025 by now.

So in both cases, extending AIDAinnova by 6 months, will allow to still get the test results within the project.

- AIDAinnova offers a **unique forum** to exchange knowhow, unfold synergies and enhance coherence in European detector R&D

- AIDAinnova offers a **unique forum** to exchange knowhow, unfold synergies and enhance coherence in European detector R&D
- It is unique in creating coherence across national funding mechanisms

- AIDAinnova offers a **unique forum** to exchange knowhow, unfold synergies and enhance coherence in European detector R&D
 - It is unique in creating coherence across national funding mechanisms
- Strong leverage on matching funds

- AIDAinnova offers a **unique forum** to exchange knowhow, unfold synergies and enhance coherence in European detector R&D
 - It is unique in creating coherence across national funding mechanisms
- Strong leverage on matching funds
- Targeted applications in line with **European Strategy Update**

- AIDAinnova offers a **unique forum** to exchange knowhow, unfold synergies and enhance coherence in European detector R&D
 - It is unique in creating coherence across national funding mechanisms
- Strong leverage on matching funds
- Targeted applications in line with **European Strategy Update**
- Increased focus on integration with **industrial partners**

- AIDAInnova offers a **unique forum** to exchange knowhow, unfold synergies and enhance coherence in European detector R&D
 - It is unique in creating coherence across national funding mechanisms
- Strong leverage on matching funds
- Targeted applications in line with **European Strategy Update**
- Increased focus on integration with **industrial partners**
- AIDAInnova is running well

- AIDAinnova offers a **unique forum** to exchange knowhow, unfold synergies and enhance coherence in European detector R&D
 - It is unique in creating coherence across national funding mechanisms
- Strong leverage on matching funds
- Targeted applications in line with **European Strategy Update**
- Increased focus on integration with **industrial partners**
- AIDAinnova is running well
 - Most Milestones have been met

- AIDAinnova offers a **unique forum** to exchange knowhow, unfold synergies and enhance coherence in European detector R&D
 - It is unique in creating coherence across national funding mechanisms
- Strong leverage on matching funds
- Targeted applications in line with **European Strategy Update**
- Increased focus on integration with **industrial partners**
- AIDAinnova is running well
 - Most Milestones have been met
 - Most Deliverables should be achieved by the end of the project

- AIDAinnova offers a **unique forum** to exchange knowhow, unfold synergies and enhance coherence in European detector R&D
 - It is unique in creating coherence across national funding mechanisms
- Strong leverage on matching funds
- Targeted applications in line with **European Strategy Update**
- Increased focus on integration with **industrial partners**
- AIDAinnova is running well
 - Most Milestones have been met
 - Most Deliverables should be achieved by the end of the project
 - A 6 month extension of the project would guarantee that all Deliverables and Milestones are met.

- AIDAinnova offers a **unique forum** to exchange knowhow, unfold synergies and enhance coherence in European detector R&D
 - It is unique in creating coherence across national funding mechanisms
- Strong leverage on matching funds
- Targeted applications in line with **European Strategy Update**
- Increased focus on integration with **industrial partners**
- AIDAinnova is running well
 - Most Milestones have been met
 - Most Deliverables should be achieved by the end of the project
 - A 6 month extension of the project would guarantee that all Deliverables and Milestones are met.
- Highly motivated community: already preparing for the next EC call for detectors