

# *Pixel tracker for the Mu3e experiment*

Ashley McDougall on behalf of the Mu3e collaboration



Silicon tracking and vertex detector technologies workshop

Queen Mary, University of London | 07.11.23



Aim to observe the process  $\mu^+ \rightarrow e^+e^-e^+$

## Lepton flavour violating decay in the SM

- Charged LFV decays forbidden at tree level (Induced through lepton mixing at higher orders)
- Predicted  $\text{BR}(\mu \rightarrow eee) \sim 10^{-55}$  [[arXiv](#)]

BSM models involving LFV could significantly enhance the predicted BR (e.g. triple Higgs doublet model)

## Anticipated sensitivity $\text{BR}(\mu \rightarrow eee) \sim 10^{-16}$

- Best current upper limit:  $\text{BR}(\mu \rightarrow eee) < 10^{-12}$  @ 90% C.L. from [SINDRUM \(1988\)](#)

## Complementary to other similar searches:

- Direct LHC searches
- Indirect searches of tau and other muon decays ( $\mu^+ \rightarrow e^+\gamma$ )

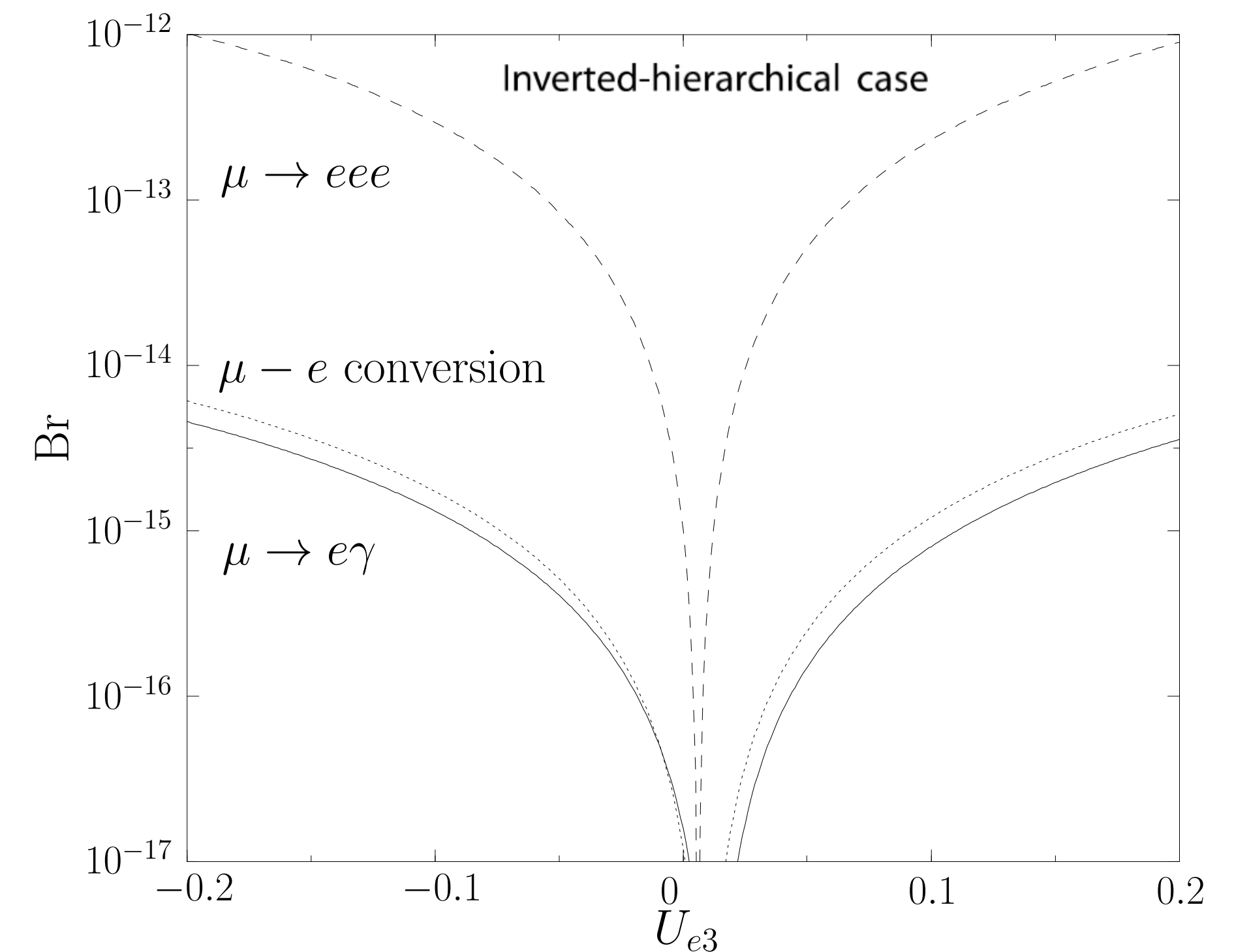
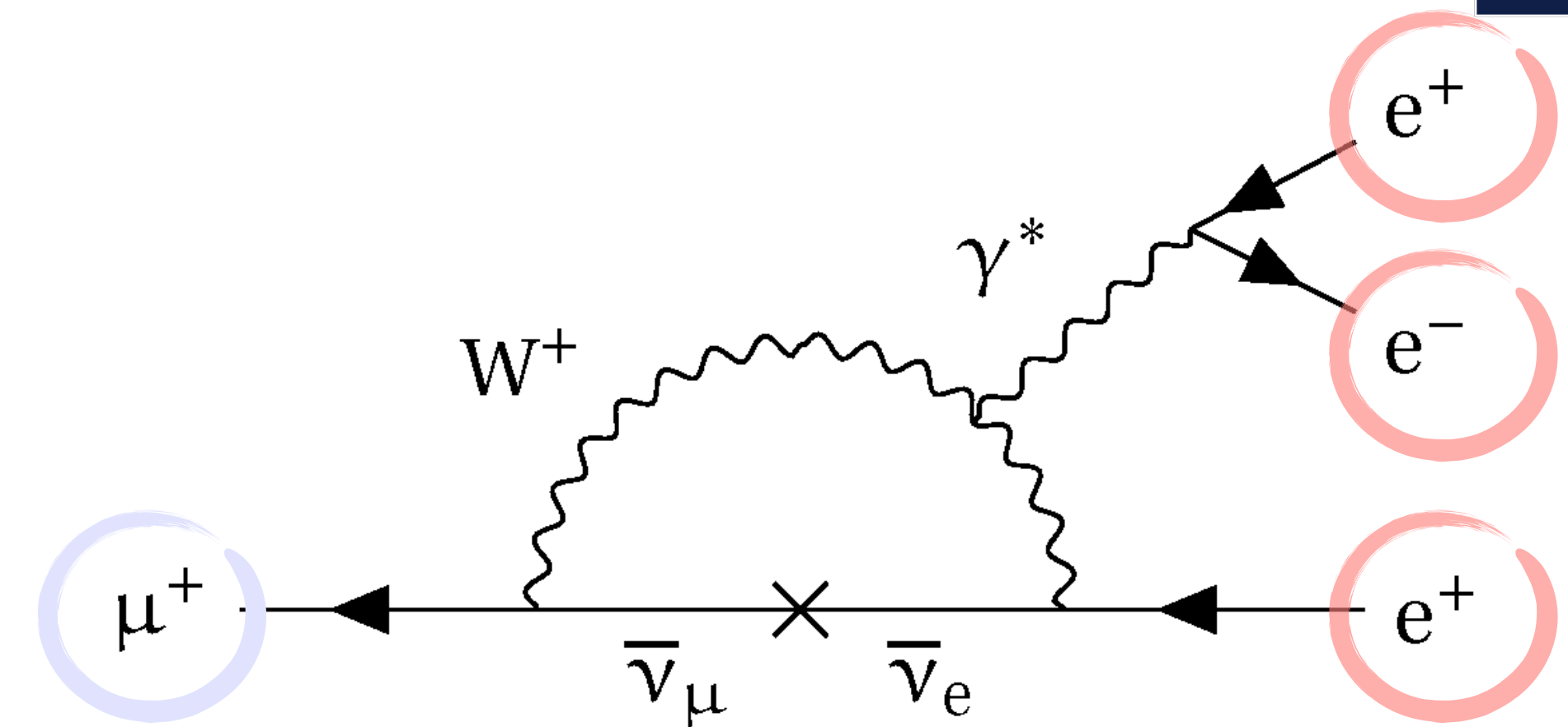

## Signal topology: three electron tracks

- Common vertex
- Time coincidence
- Energy sum =  $m_\mu$
- Decay at rest so  $\sum \vec{p} = 0$

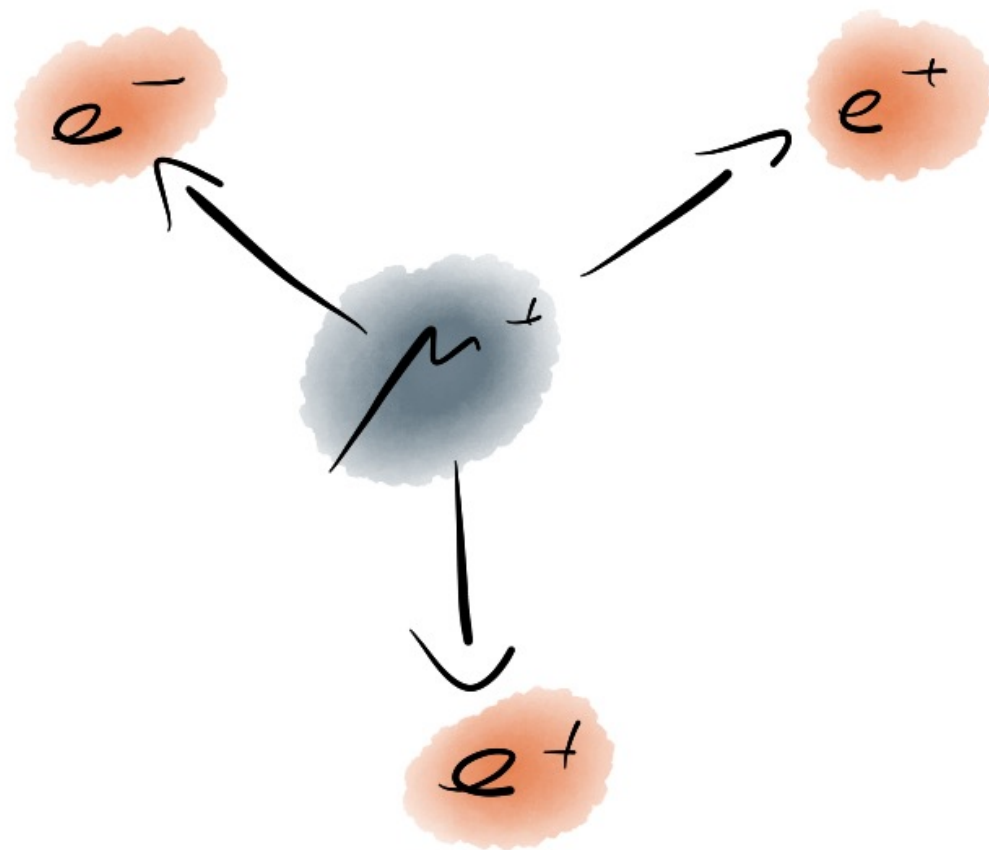

- Sensitivity dependant on reduction of dominant processes which resemble signal

## Main backgrounds:

- Internal conversion (small energy carried away by neutrinos):  
 $BR(\mu \rightarrow eee\nu\nu) = (3.4 \pm 0.4) \times 10^{-5}$

- Accidental: processes appearing to have 3e tracks.

Can occur via: Misreconstruction,  $\gamma$  conversion, Bhabha scattering

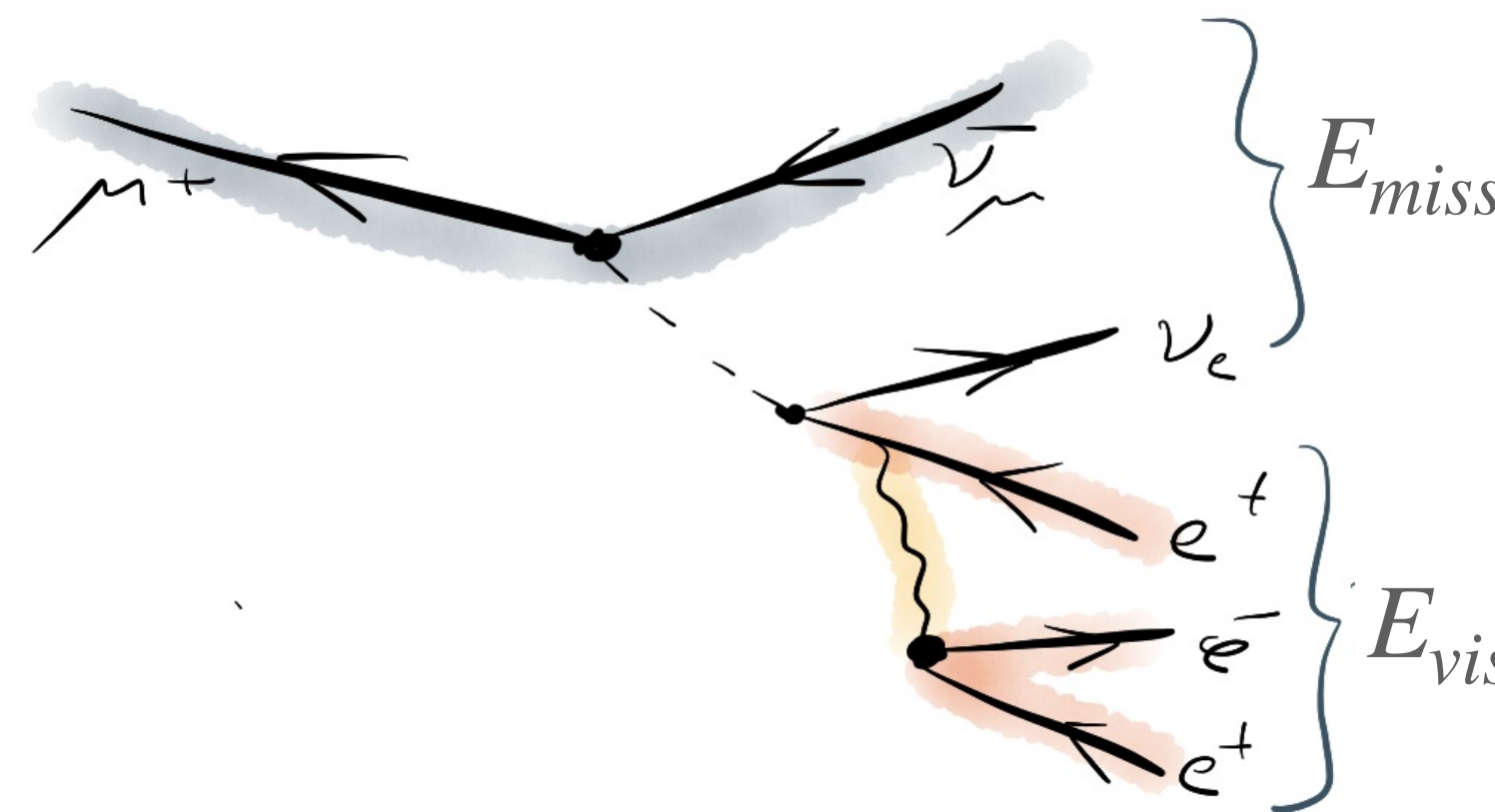

## Detector requirements:

- Precise momentum resolution (*material budget important!*)
- Good timing and vertex resolution (to identify the signal)
- Large acceptance

# Mu3e location and collaboration:

A. McDougall



Located at the Paul Scherrer Institute (PSI) near Zurich, CH

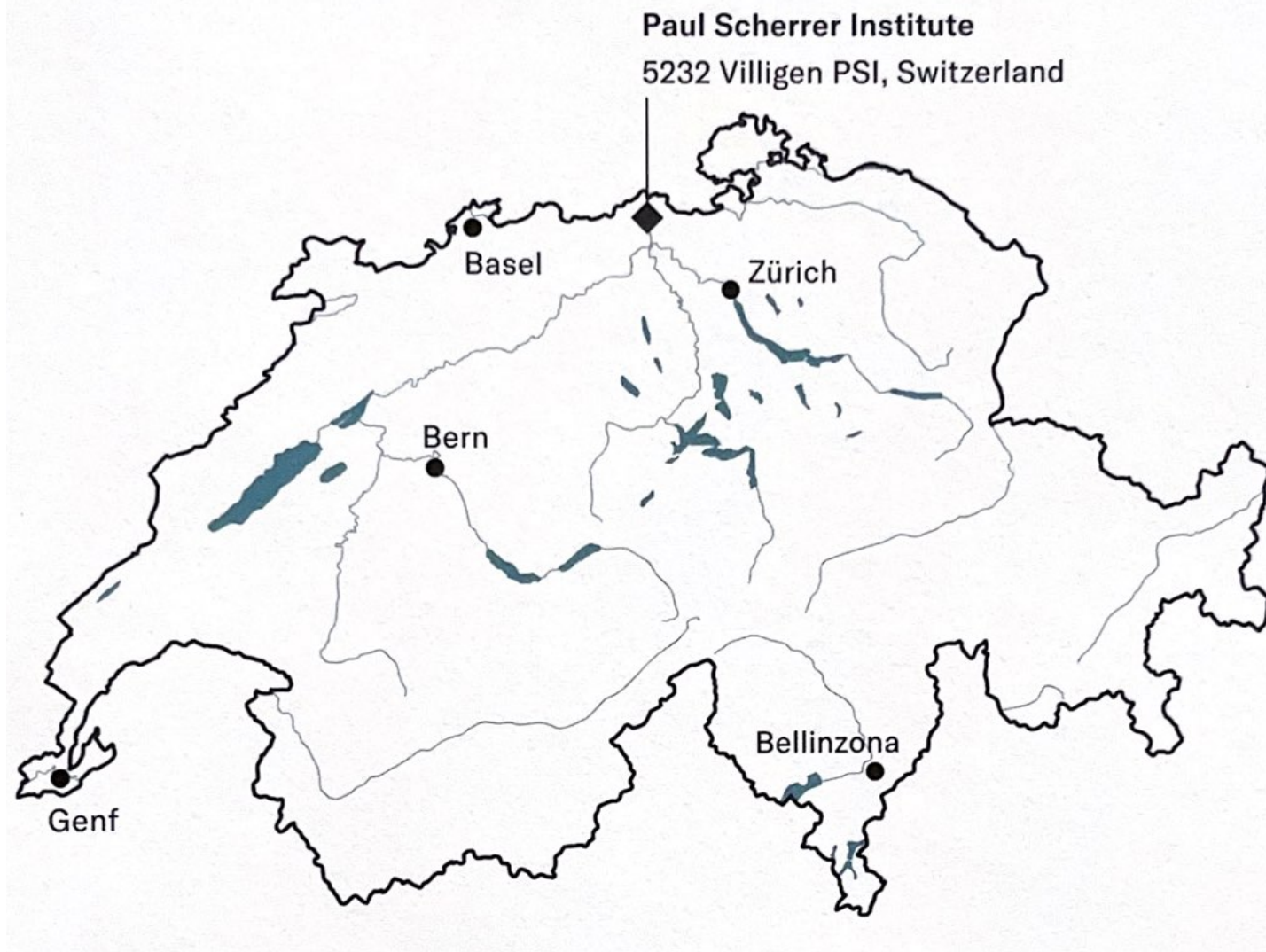

- Swiss national accelerator complex
- Mu3e to be located in experimental hall along low-energy muon beam line
- Provides muon rates up to  $\sim 1 \cdot 10^8$  Hz

**Expected to start taking physics data in 2025:**

- 290 days *minimum* running time required to achieve target sensitivity

Collaboration  $\mathcal{O}$ (80 people) from 11 institutes (Germany, UK, Switzerland):



UNIVERSITÉ DE GENÈVE



Universität Zürich UZH



UNIVERSITÄT HEIDELBERG  
ZUKUNFT SEIT 1386



UNIVERSITY OF OXFORD



JOHANNES GUTENBERG UNIVERSITÄT MAINZ

1 Make muons  
•  $\pi E5$  beam line @ PSI

2 Stop the muons

Hollow double cone stopping target:

- Aluminised Mylar foil 70-80 $\mu$ m thickness, 100mm length, 19mm radius.
- $\sim 95.5\%$  of muons reaching the target are stopped
- Very similar to that used by [SINDRUM](#)

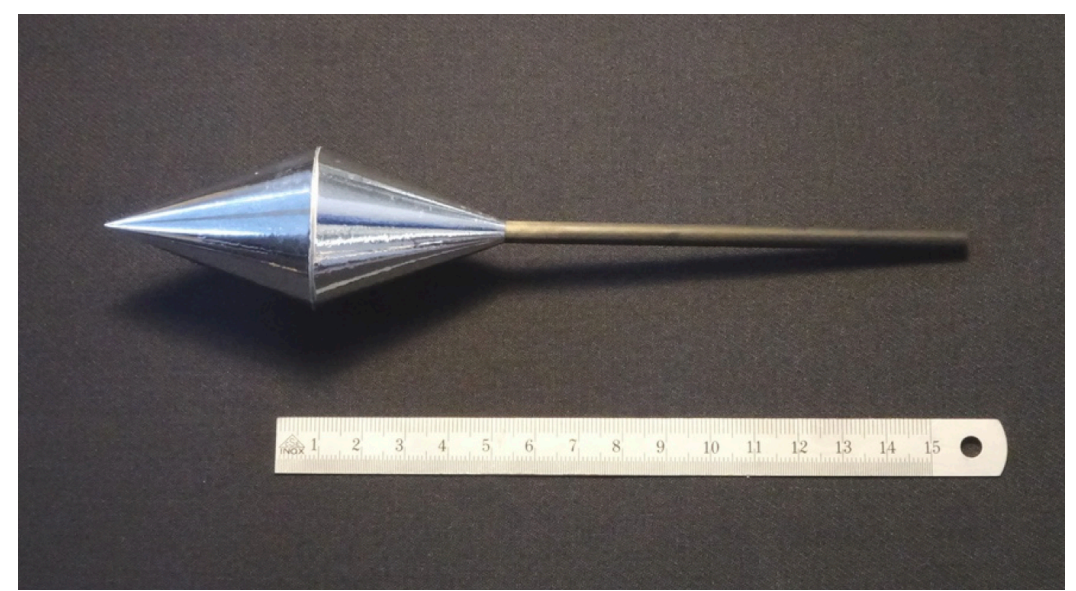

3 Detect the muons

Detector geometry:

- **Central region:** pixel tracker + scintillating fibres
- **Re-curl region:** pixel tracker + scintillator tiles

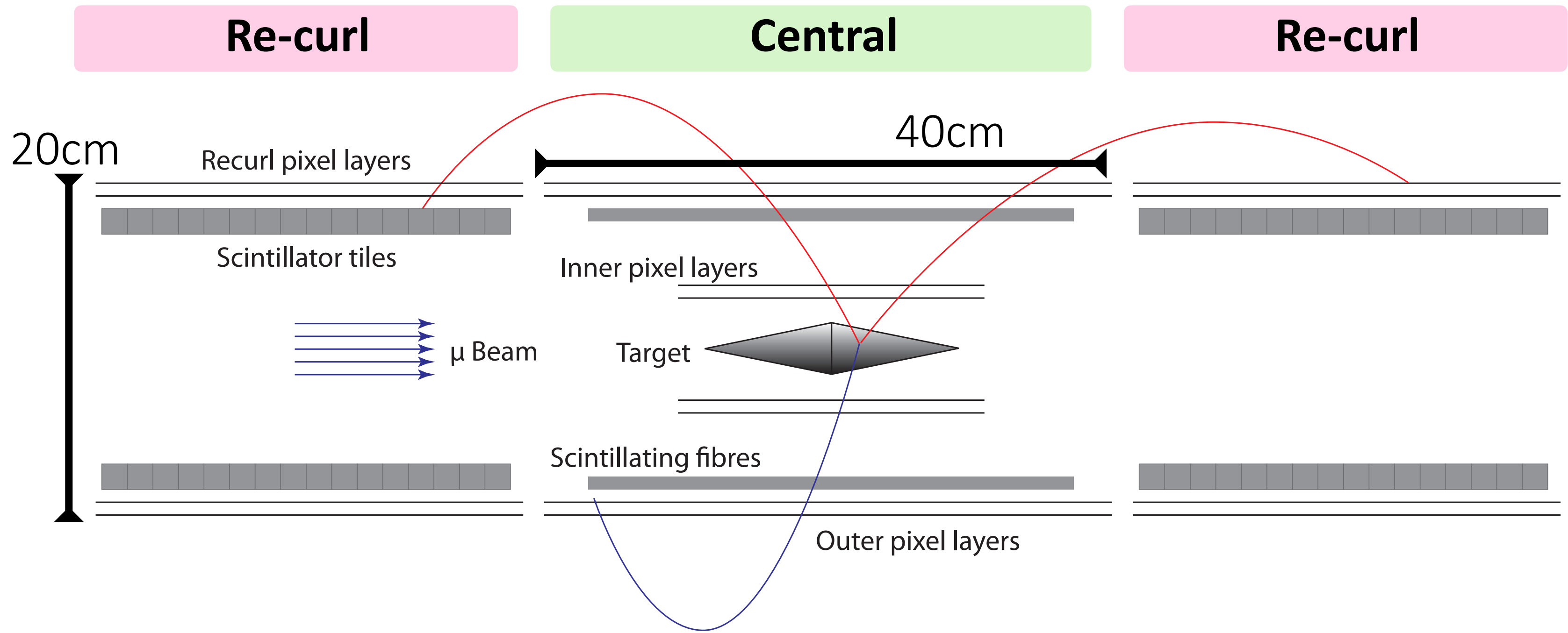

- Tracking achieved with:
- Homogeneous solenoidal magnetic field  $B = 1T$
  - Four-layer silicon pixel detector (+ re-curl)
  - Scintillating fibres: differentiate electrons and positrons
  - Scintillating tiles: further improve timing resolution

Require excellent momentum (energy) resolution to reduce  $\mu \rightarrow eee\nu\nu$  background

- Small pixel sizes = hit resolution effects can be neglected.
- **Resolution solely determined by multiple scattering.**

In such a regime: **track momentum resolution predominantly depends on number of detector layers & thickness.**

For tracking:

- Use very thin (50-70 $\mu\text{m}$ ) pixel sensors, with integrated hit digitisation and readout circuitry



Cooling: use gaseous Helium cooling

- 2 flow channels: between layers + around outer layer
- Flow rate 2g/s

Maximise resolution =  
*ultra low-mass*  
detector!

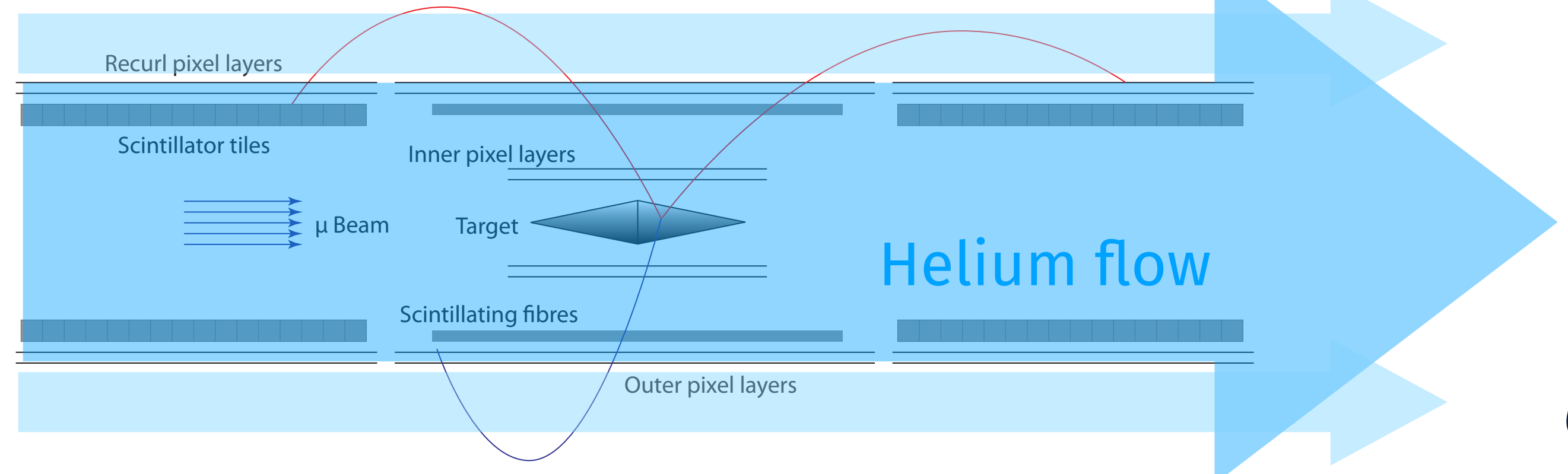

Scintillating fibres: surround inner pixel layers in central region

- Constructed of scintillating photo-multiplier tubes (SiPMs)
- 12 fibre ribbons, 30cm long, arranged in 3 staggered layers
- Fibres 250  $\mu\text{m}$  thin
- Material budget  $< 2\% X_0$
- Measured time resolution  $\sim 250$  ps

Scintillating tiles: 6mm x 6mm x 5mm tiles with SiPMs in re-curl region

- $\sim 6000$  channels
- Up to 60 kHz/channel
- Measured single channel time resolution  $< 50$ ps
- Intended to stop the electrons: no required material budget

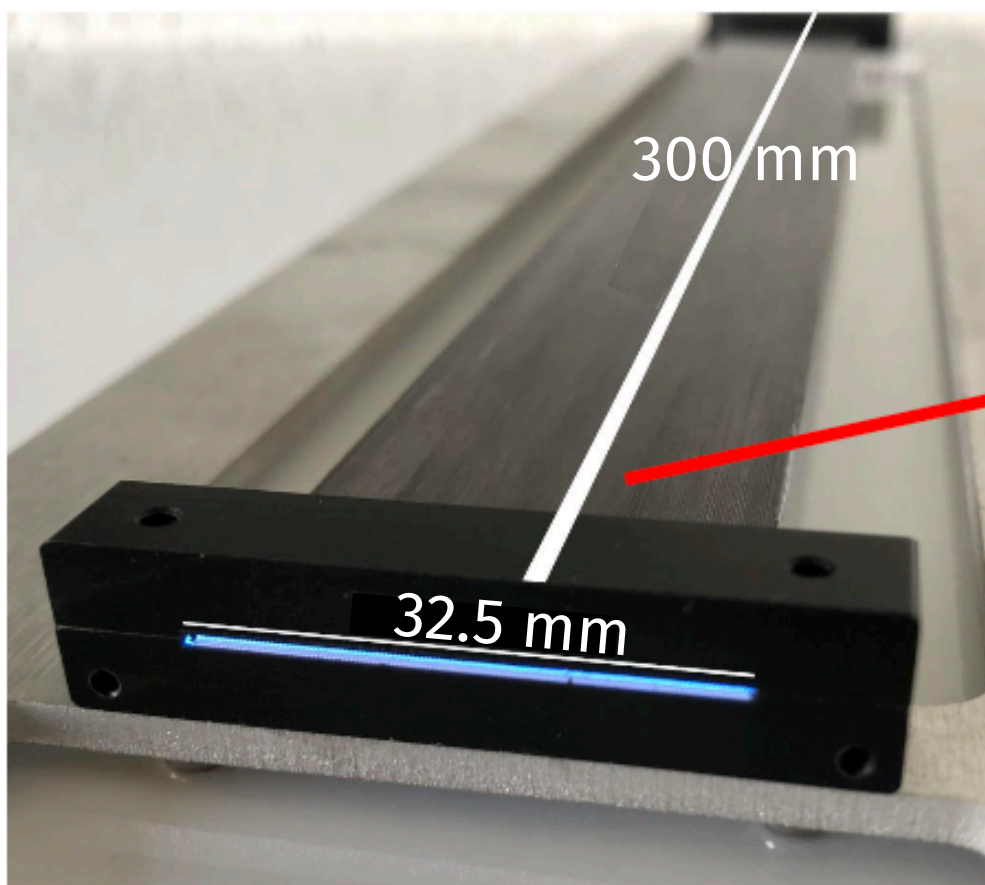

SciFi ribbons

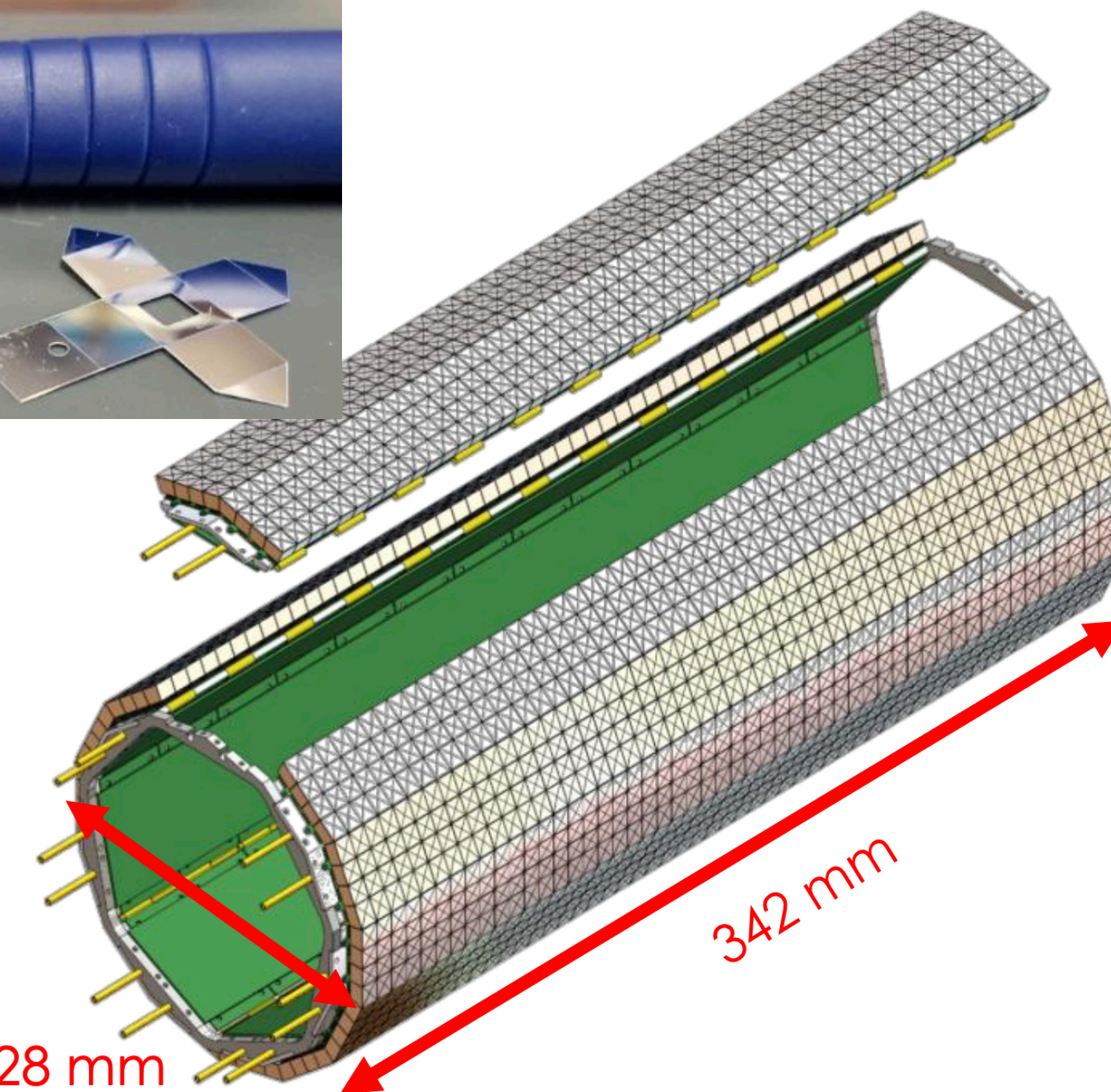
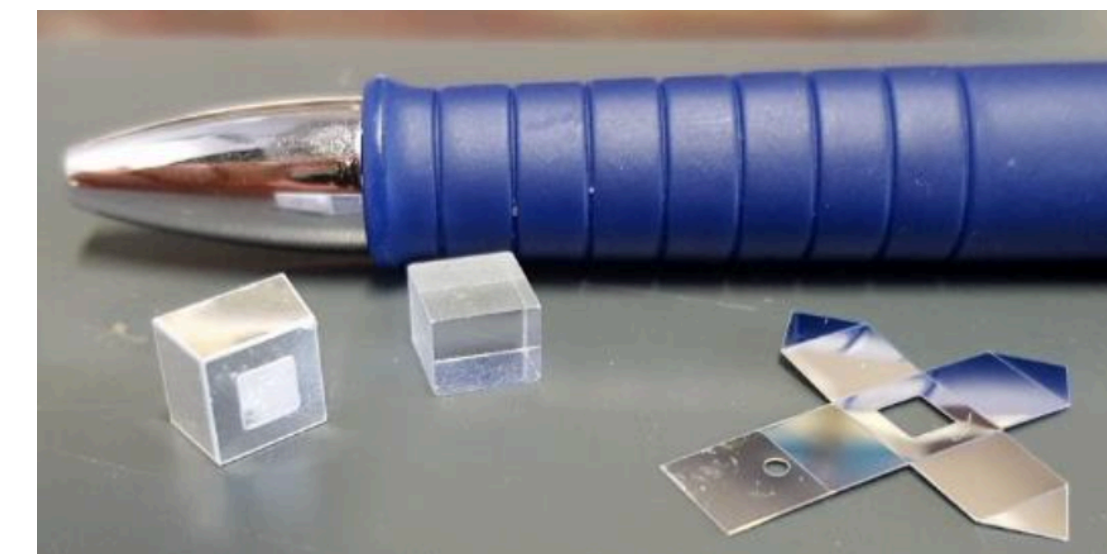
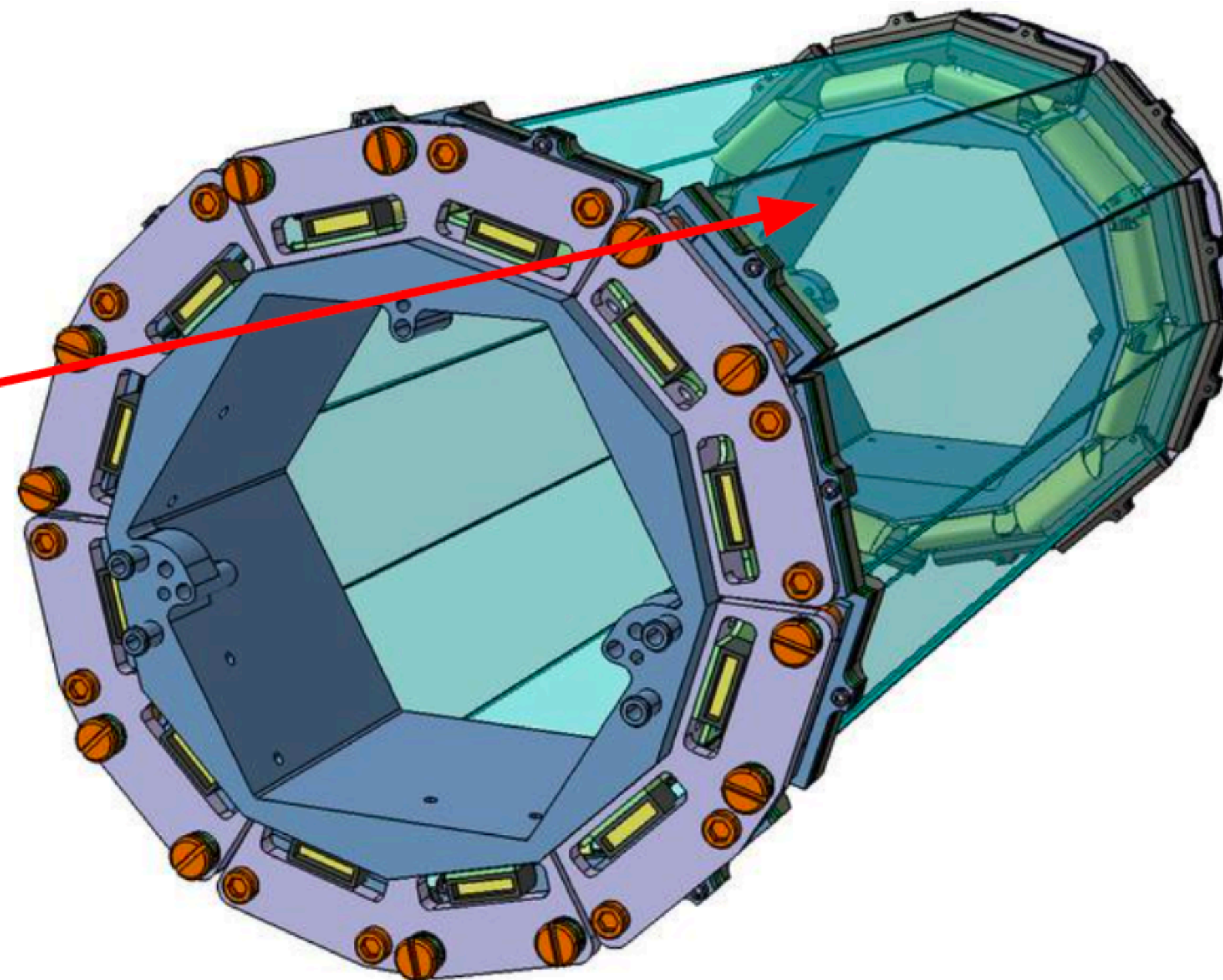

- Common read out: custom MuTRIG ASIC (50ps time-to-digital converter)

Silicon pixel detectors using **high-voltage monolithic active pixel sensor** technology (HV-MAPS)

- Provides high granularity (precision tracking and vertexing)
- Needs to be **fast** and **accurate**

Ideal sensor design requirements

spatial resolution $\mu\text{m}$	$\leq 30$
time resolution [ns]	$\leq 20$
hit efficiency [%]	$\geq 99$
#LVDS links (inner layers)	1 (3)
bandwidth per link [Gbit/s]	$\geq 1.25$
power density of sensors [ $\text{mW}/\text{cm}^2$ ]	$\leq 350$
operation temperature range [ $^{\circ}\text{C}$ ]	0 to 70

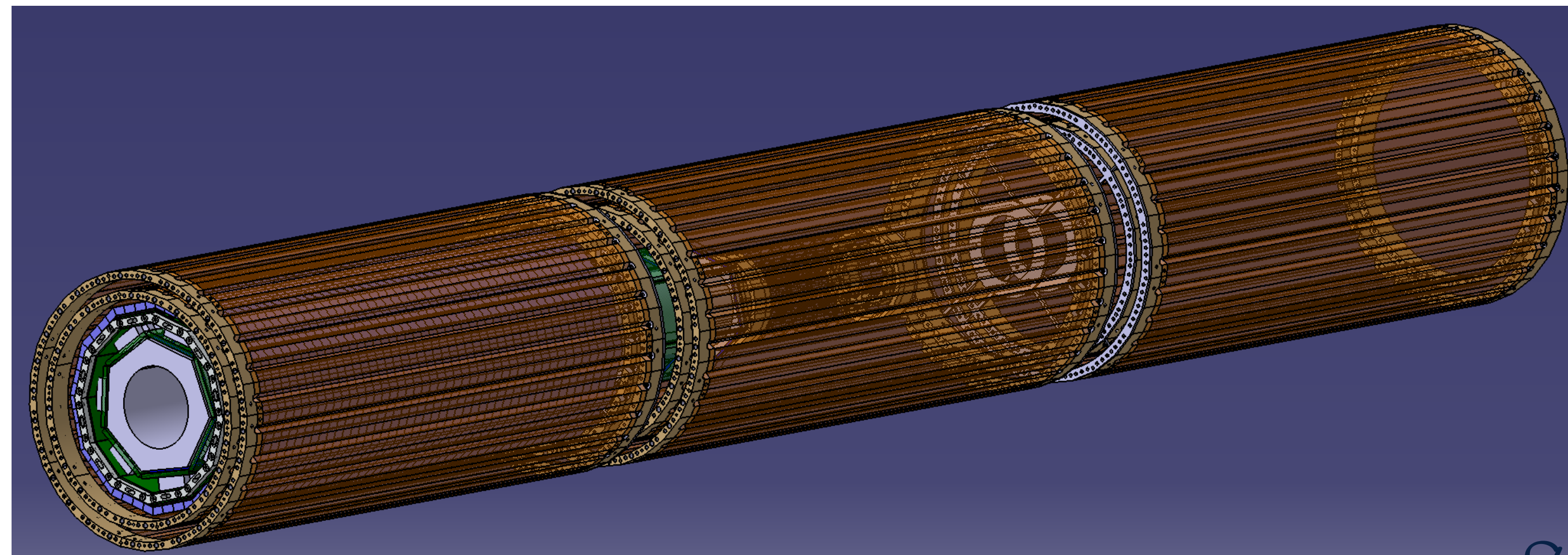
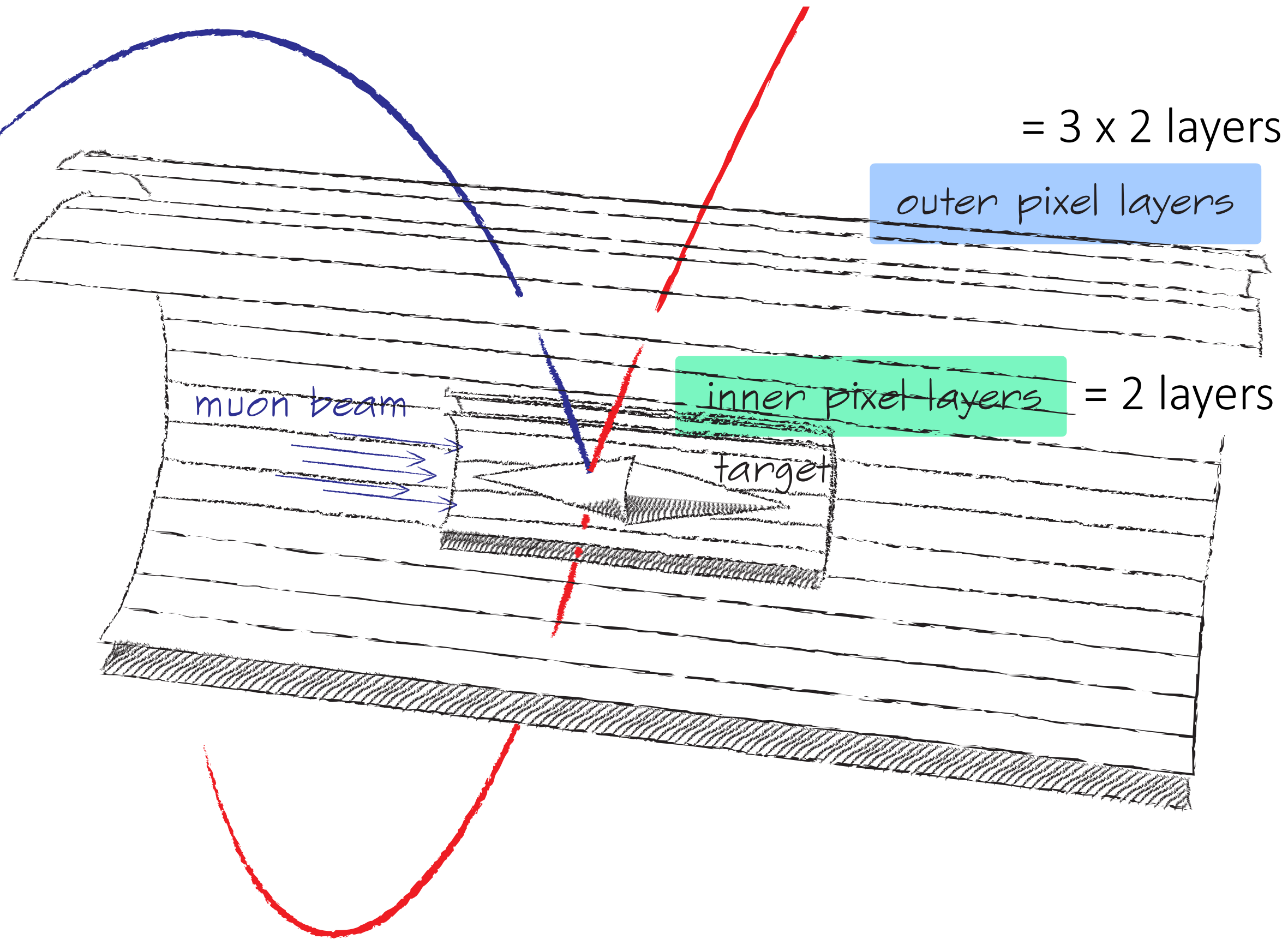
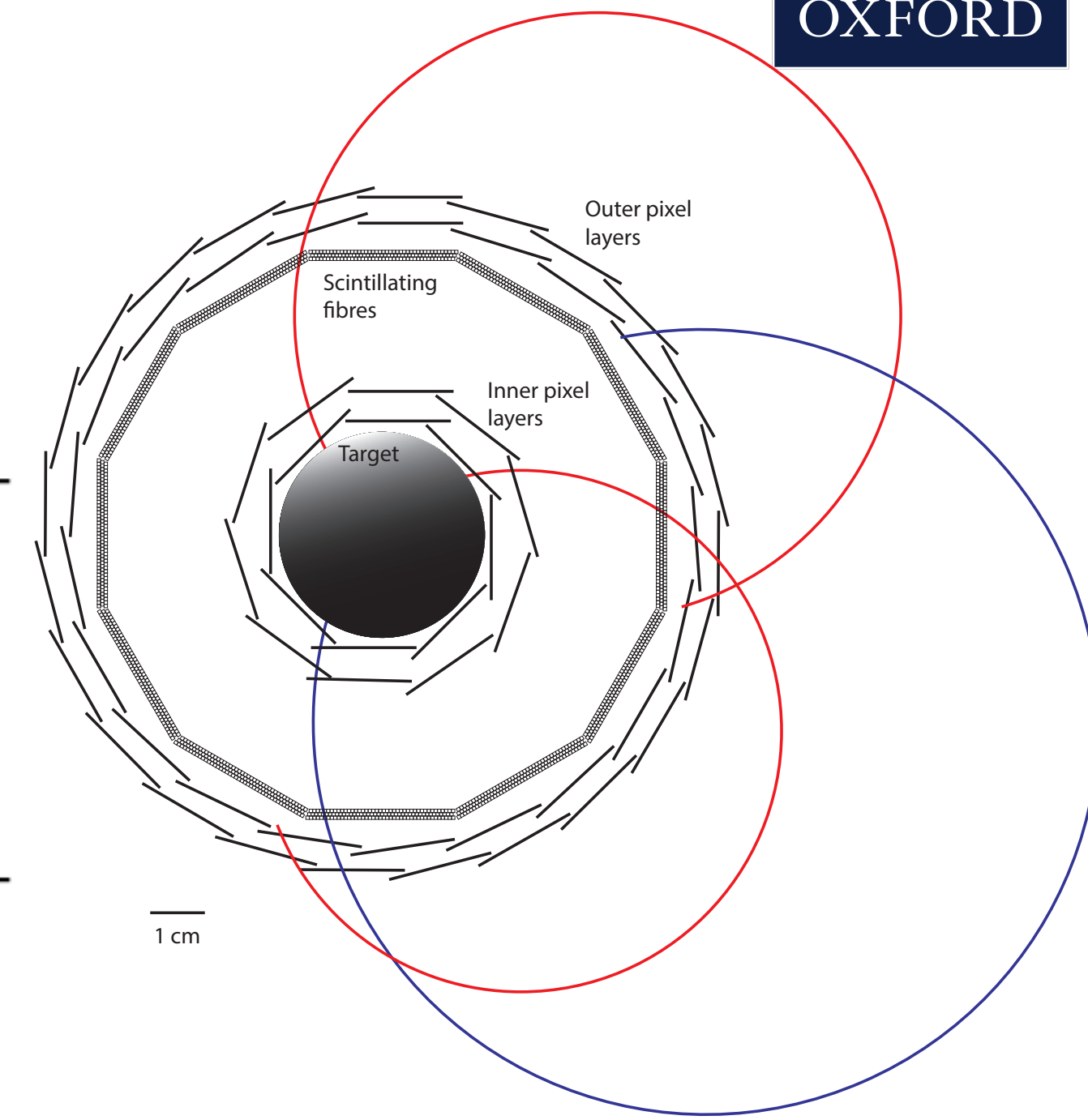



Custom **MuPix HV-MAPS** sensors: designed to be fast, efficient, thin

- Monolithic HV-CMOS: produced by TSI (Bosch) using 180 nm technology
- Fast charge collection via drift

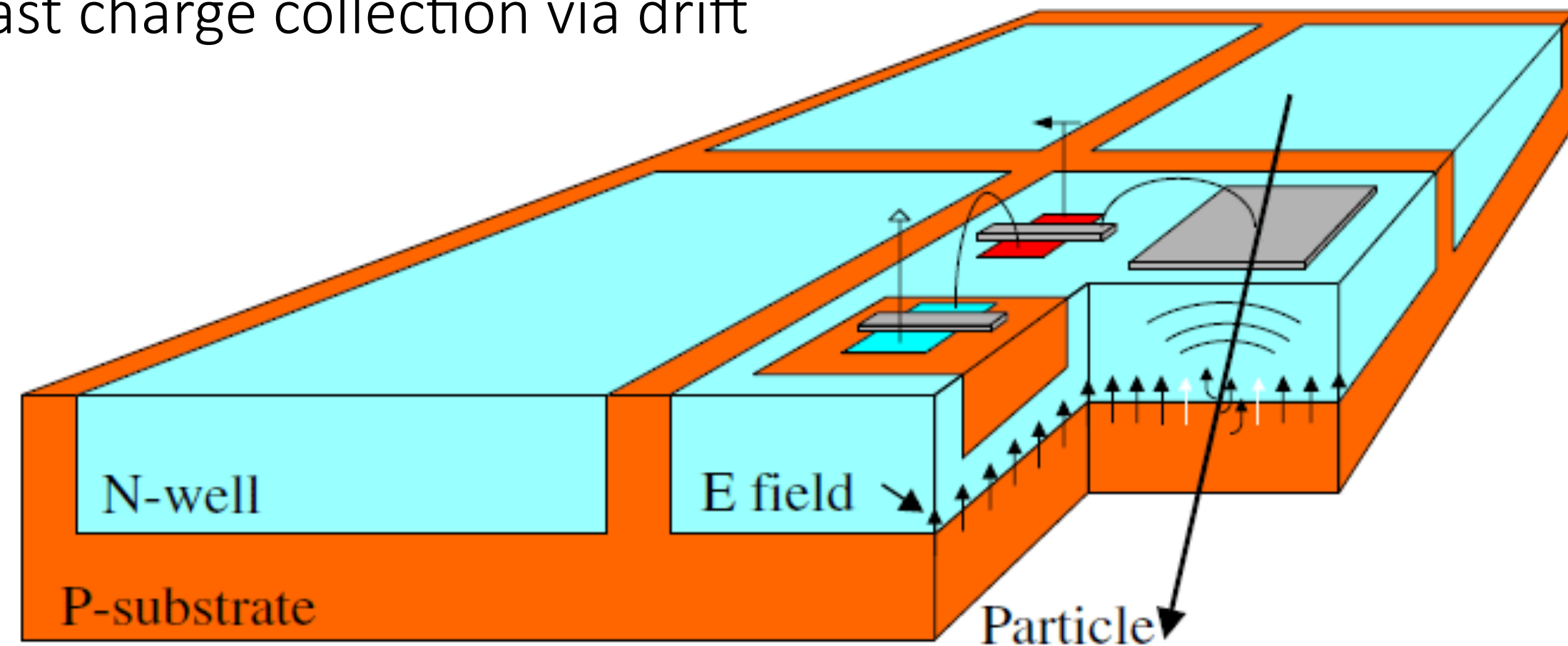

- $80 \times 80 \mu\text{m}^2$  pixels (= 256 x 250 pixels total)
- Operating voltage = 1.8 V
- $\sim 250 \text{ mW/cm}^2$  power consumption
- $< 15 \text{ ns}$  time resolution (measured 5.7 ns)
- Tunable threshold for each pixel
- Integrated analog and digital readout
- Up to 3 configurable data lines: each at a rate of 1.25 GBit/s
- Data driven readout - hits sent out as packets

Active area =  $20 \times 20 \text{ mm}^2$

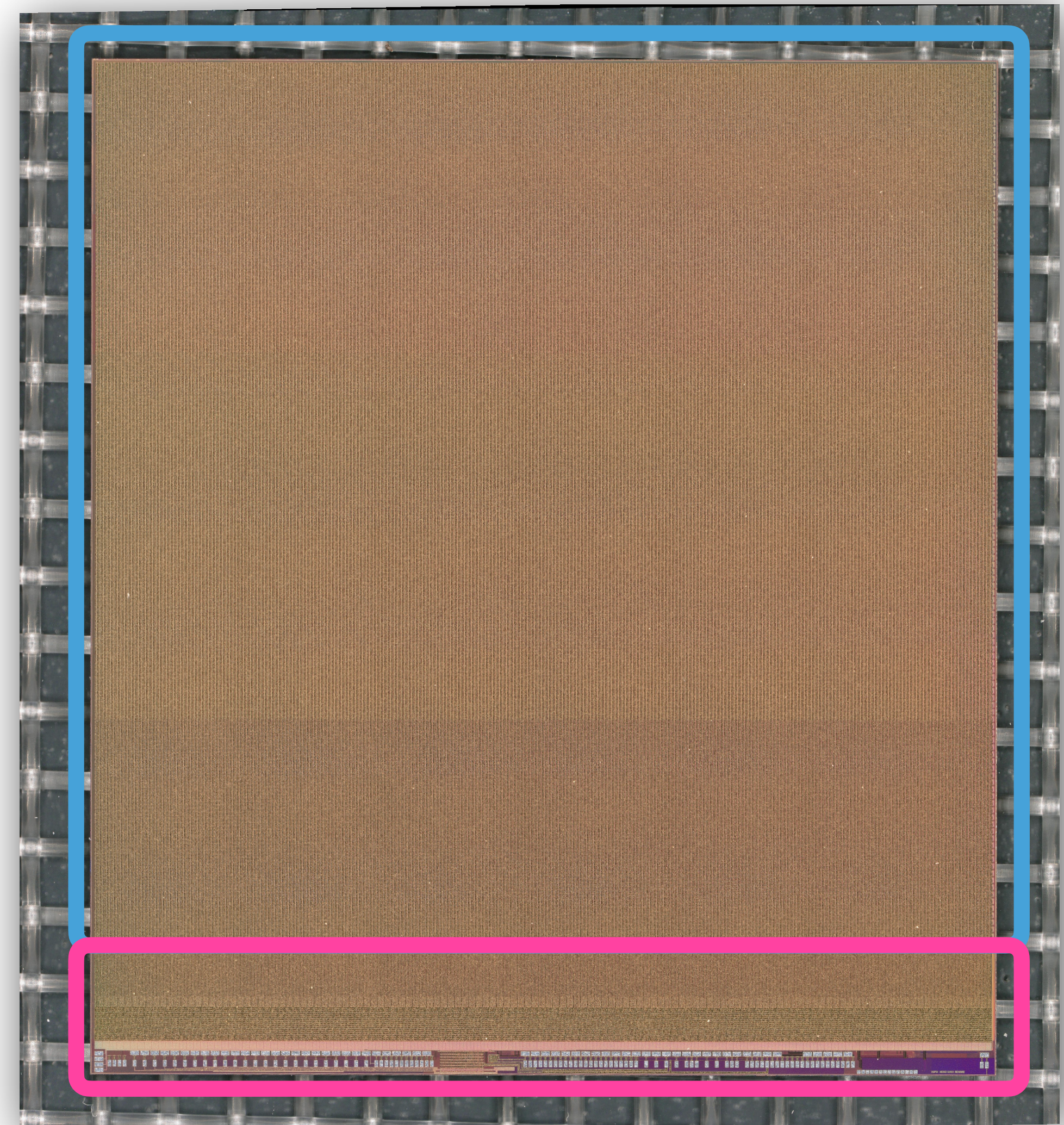

Periphery

Chips assembled into **ladders**:

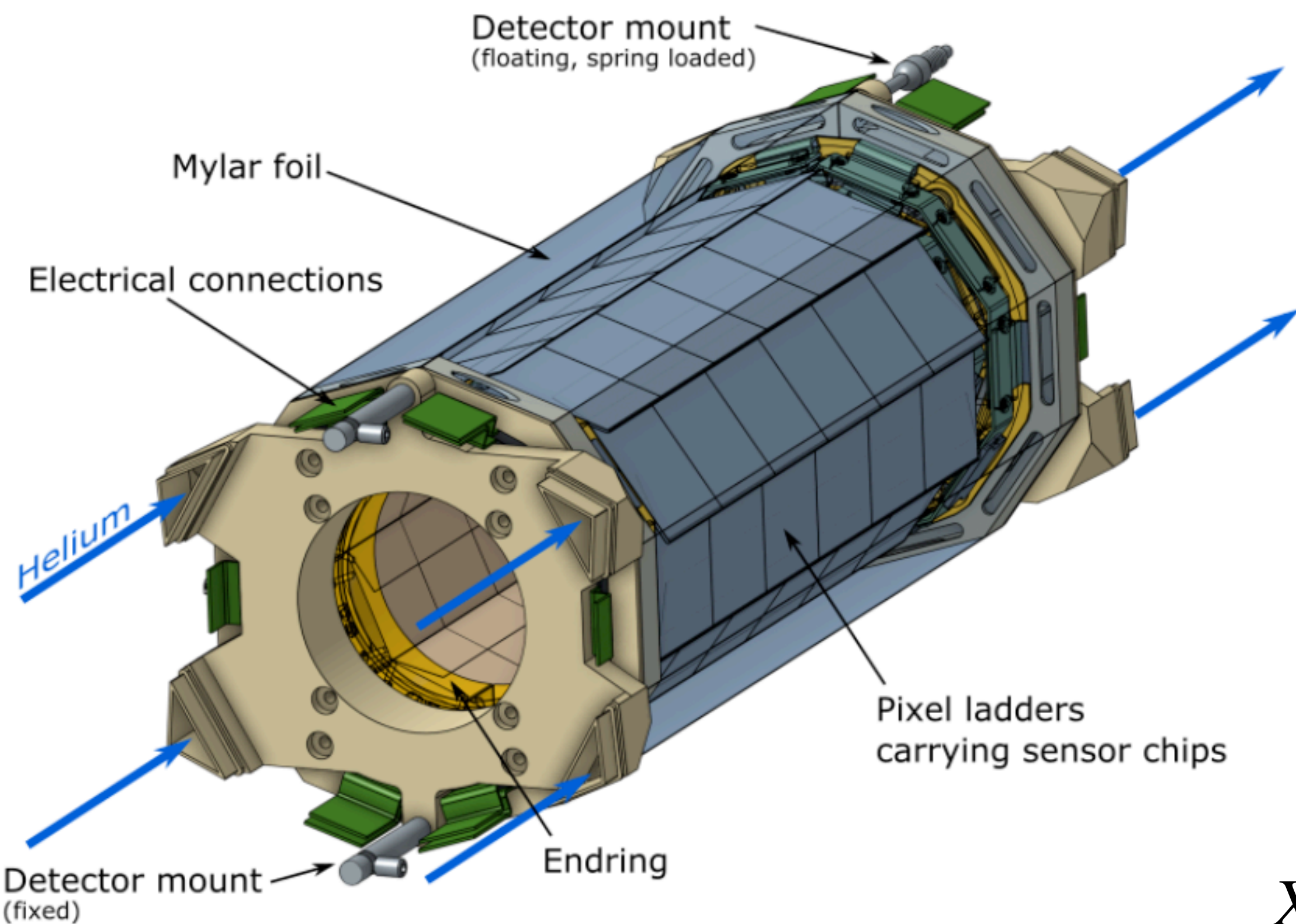
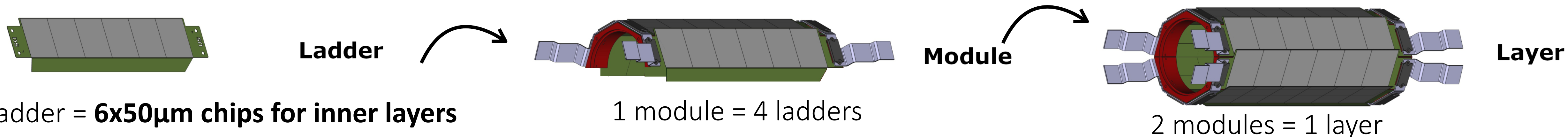

Mechanical support provided by:

- Primarily from 3D folded nature of vertex detector
- Alu/kapton high-density interconnect (HDI)
- Chips glued on + spTAB for electrical connection (Single Point Tape Automated Bonding)
- 25µm kapton support

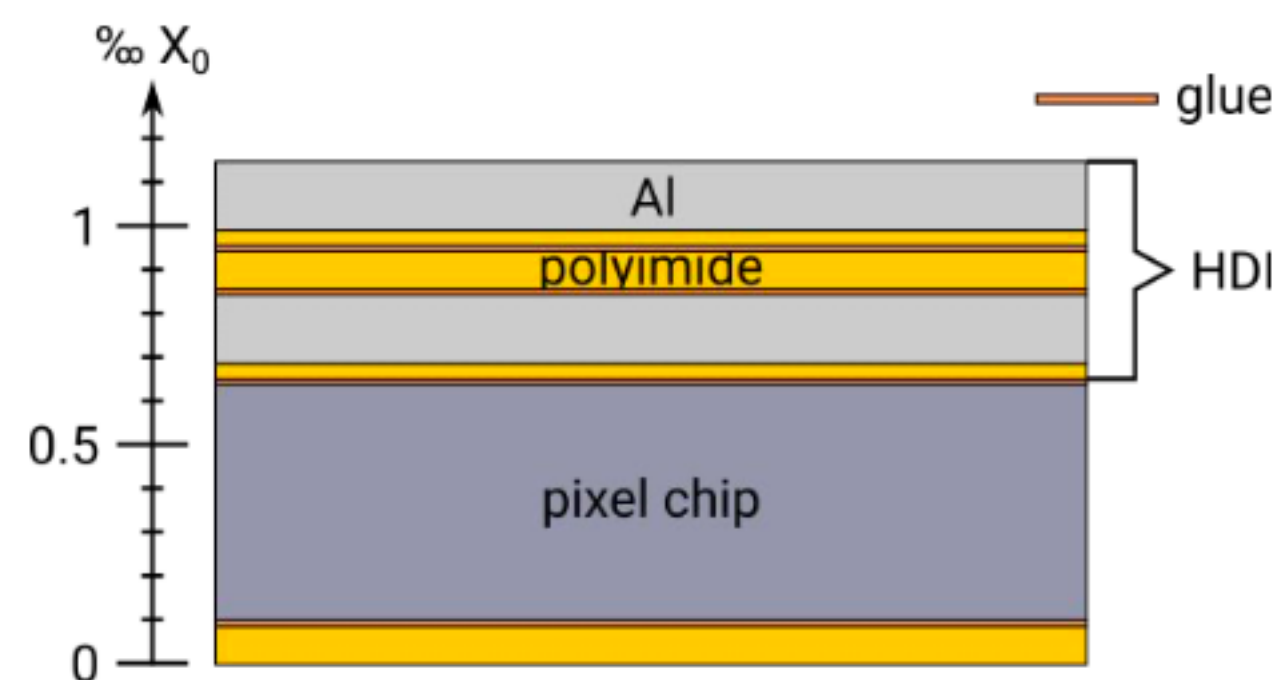

$X/X_0 \approx 1.15\%$  per tracking layer



SpTA-Bond connection: bond pads size 200 x 100 µm<sup>2</sup>

# Fabrication procedure for inner pixel layers:

A. McDougall

Test modules have been produced to conduct cooling studies, and practise assembly procedure

Single chips are tested using QC test stand with needle socket

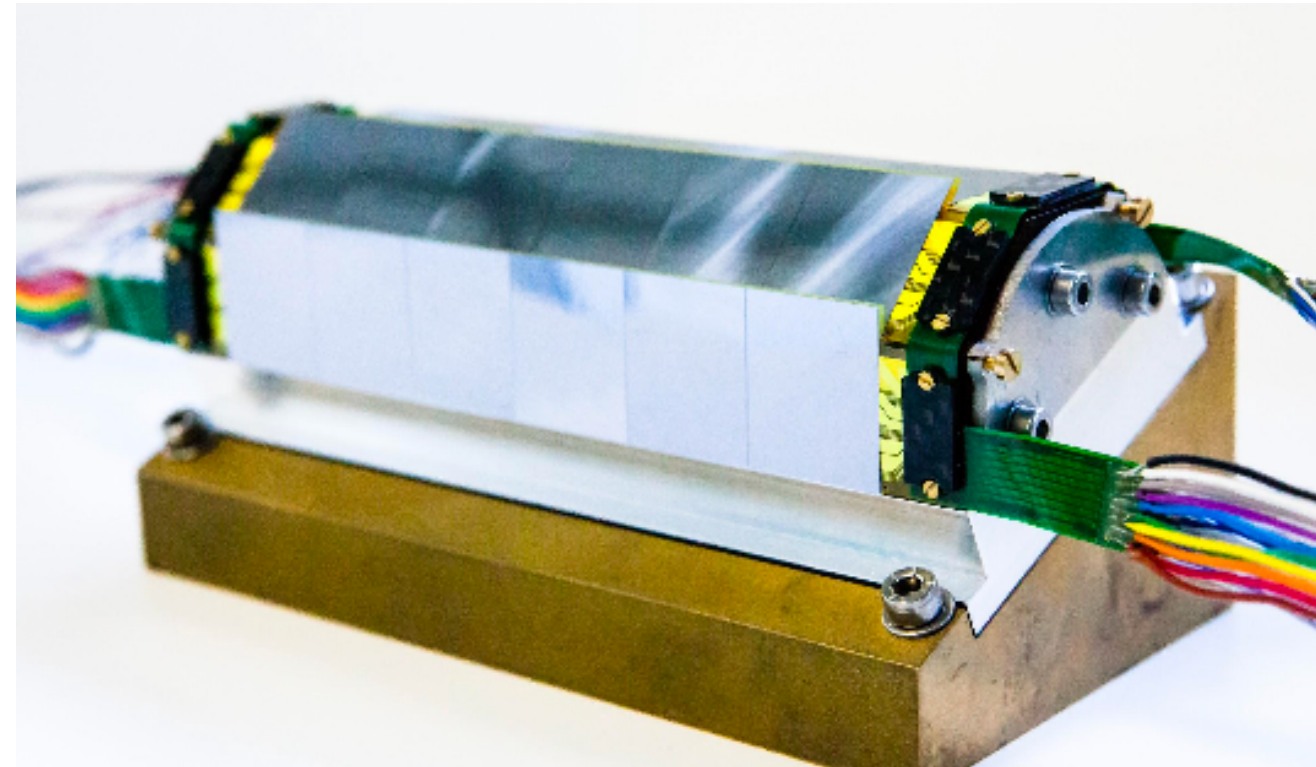
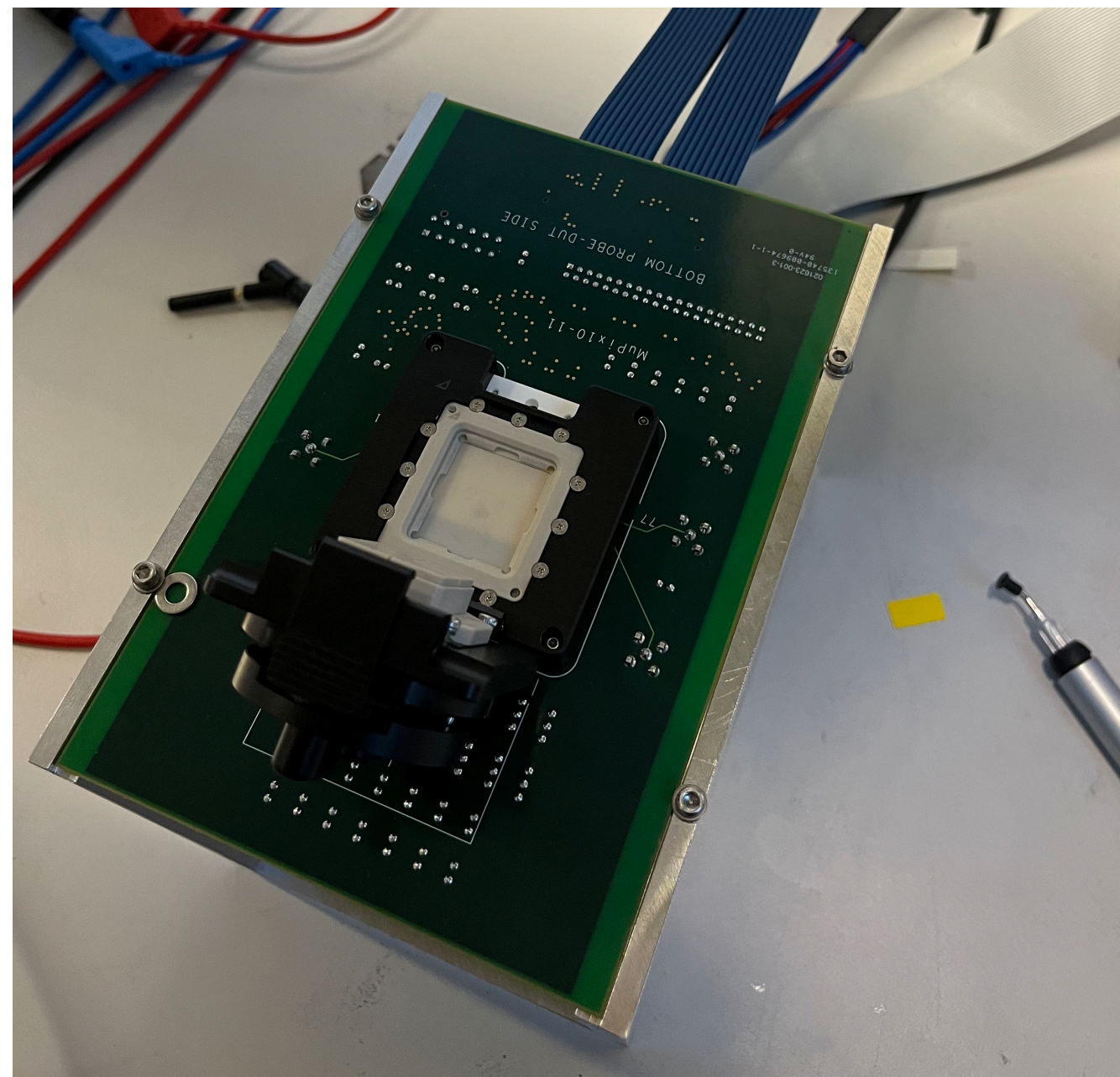

Chips and glue deposits are manually placed on ladder

- Some Origami skills required

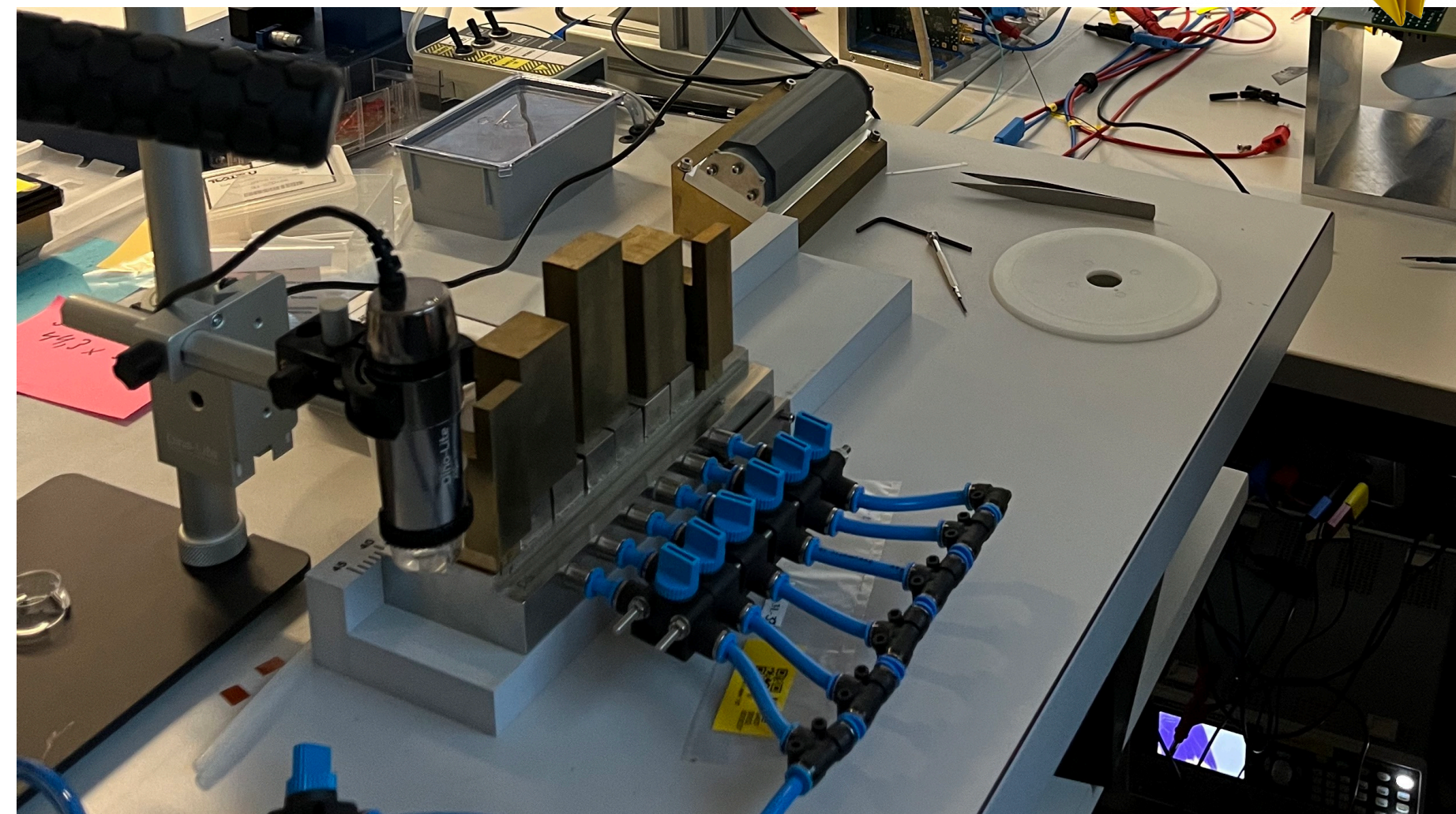

Simplified PCB-based demonstrator:

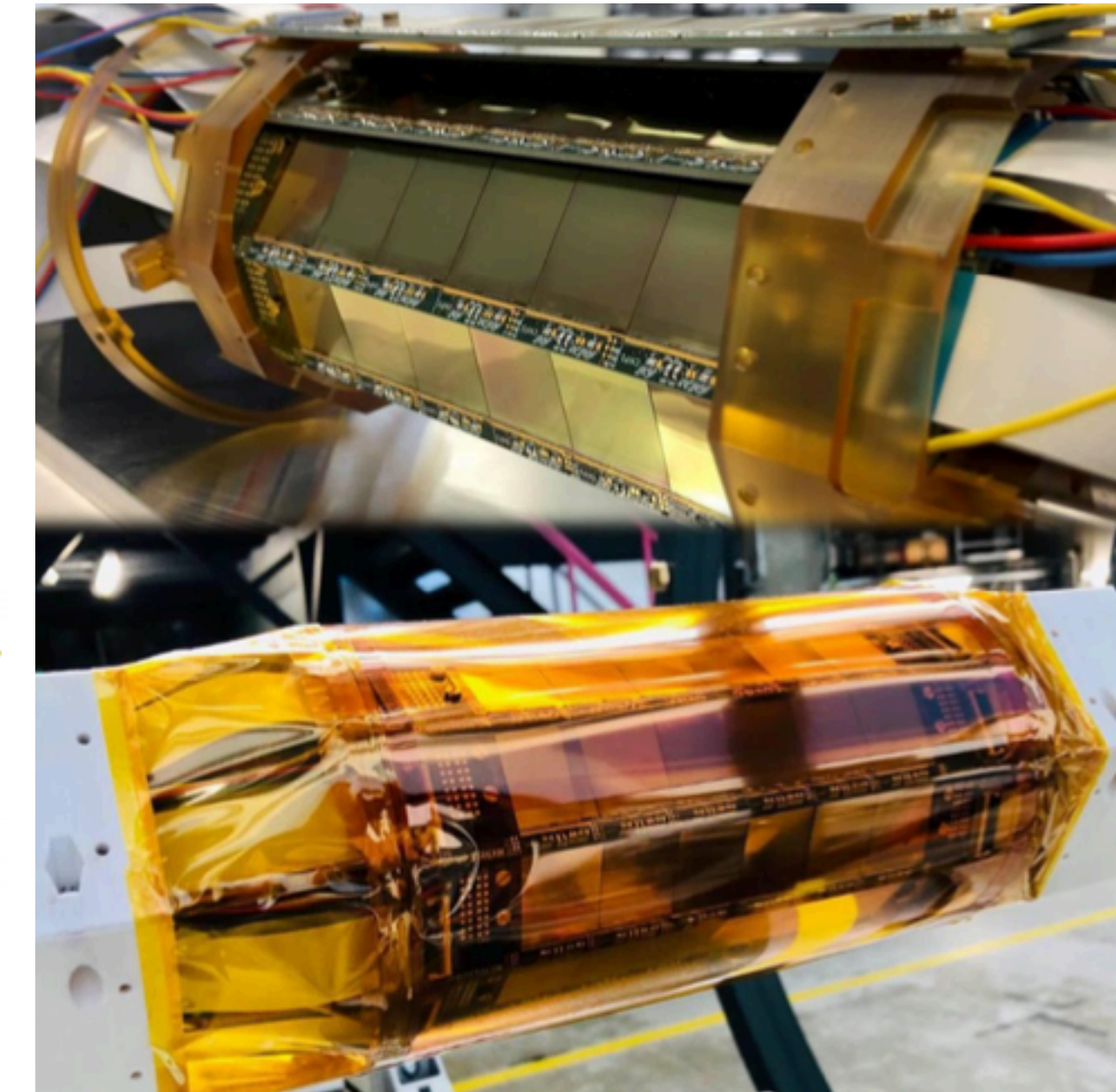

First half ladder has been inserted into testbeam @ PSI 2 weeks ago

→ successful read-out achieved!

- **70 $\mu\text{m}$  thick pixel sensors**
- 17-18 chips per ladder
- 4 ladders per module
- 6 modules in layer 3
- 7 modules in layer 4

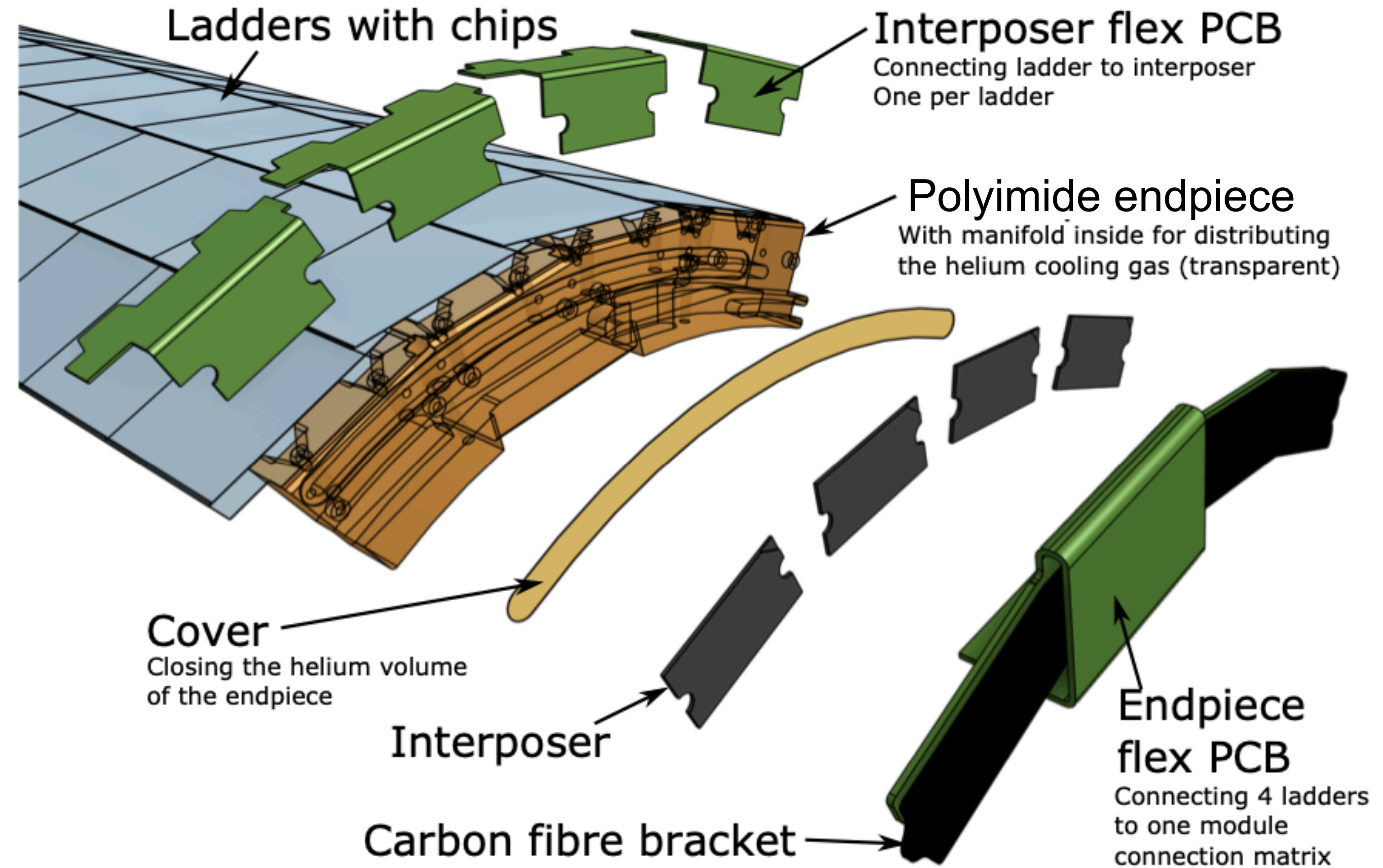
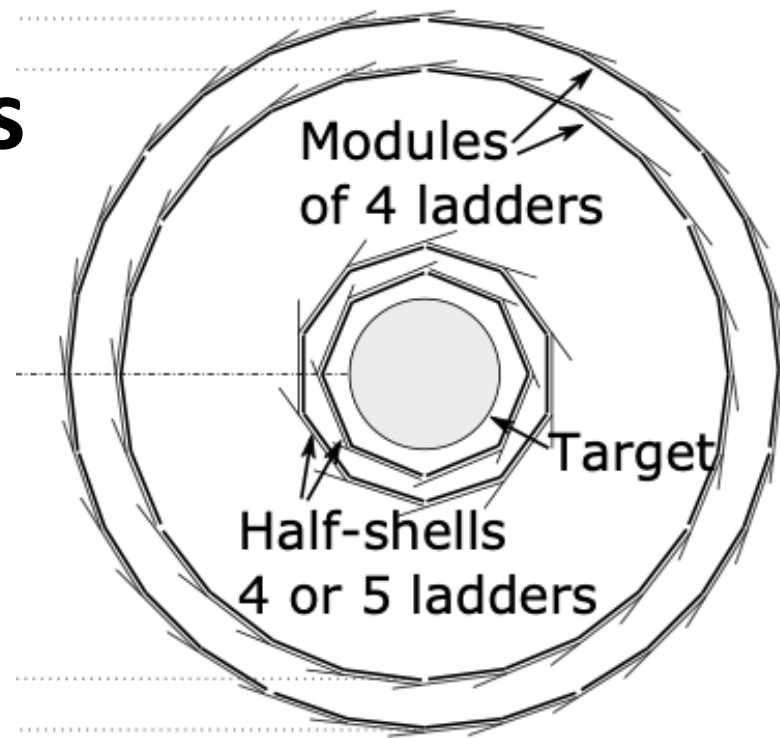

Mechanical support provided by:

- So-called “**v-folds**”: V shaped material providing structural rigidity (nominally made of kapton)

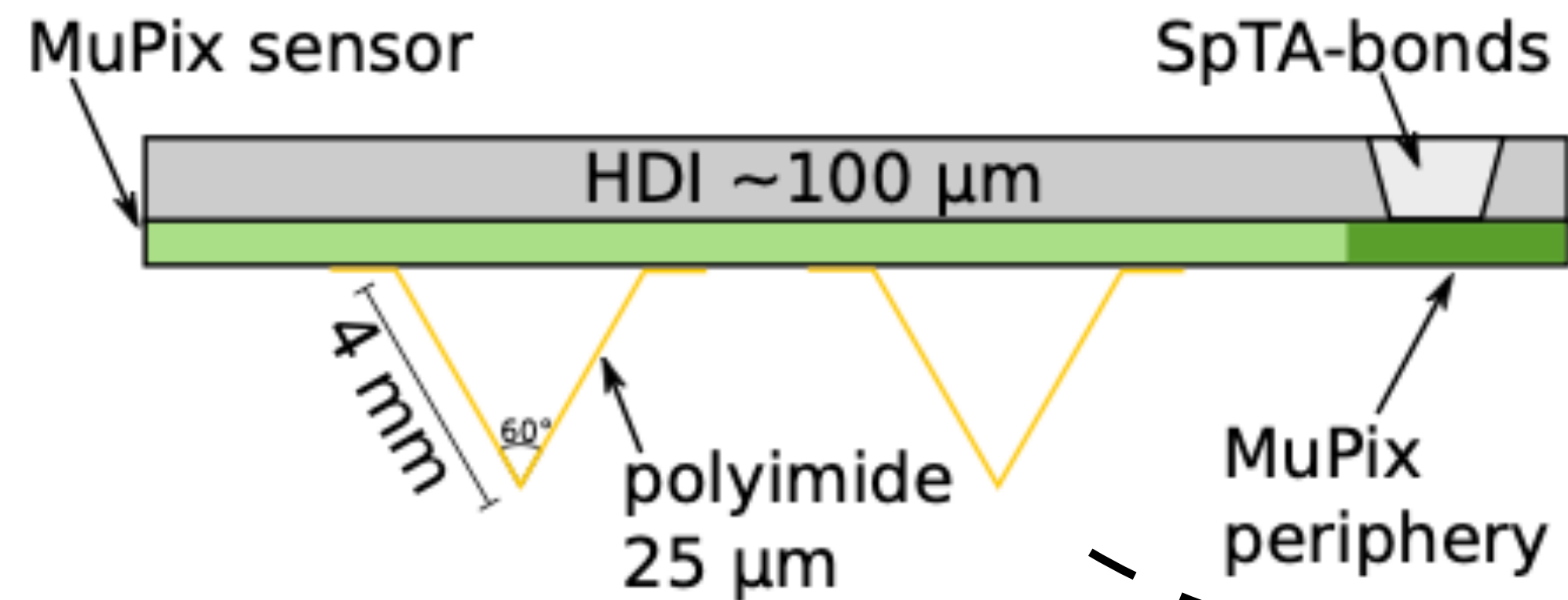

Real v-folds

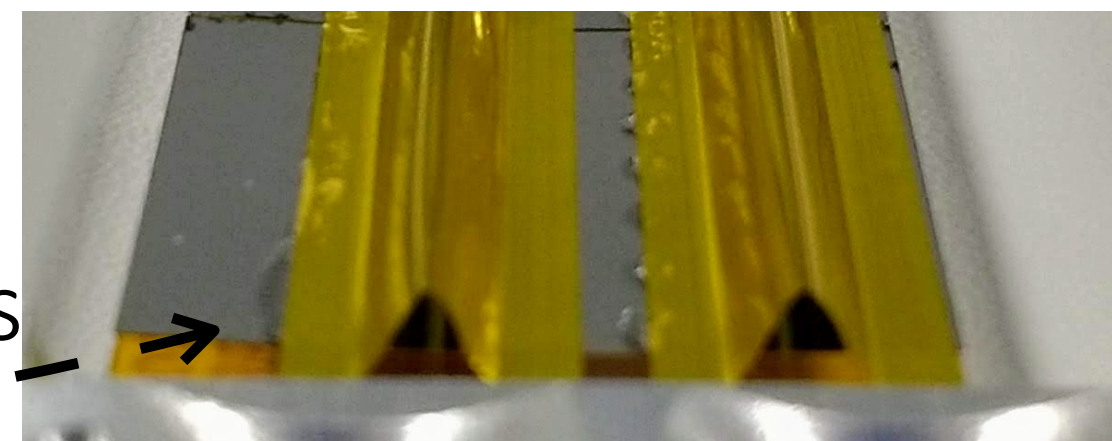

# Fabrication procedure for outer pixel layers:

A. McDougall



Significantly more, and larger, ladders required for outer pixels versus inner system. Exact ladder yield not yet known.

- **Total = 912 chips (central) + 2x912 chips (re-curl) versus 96 for vertex layers**
- Anticipate  $\mathcal{O}(60\%)$  yield for pixel chips passing QC, further  $\mathcal{O}(60\%)$  for ladder QC.
  - **Need to test 3x2000 chips in total!**



Production taking place @ Oxford

Automise ladder building procedure as much as possible:

- Robotic gantry used for placement of chips on vacuumed ladder tool

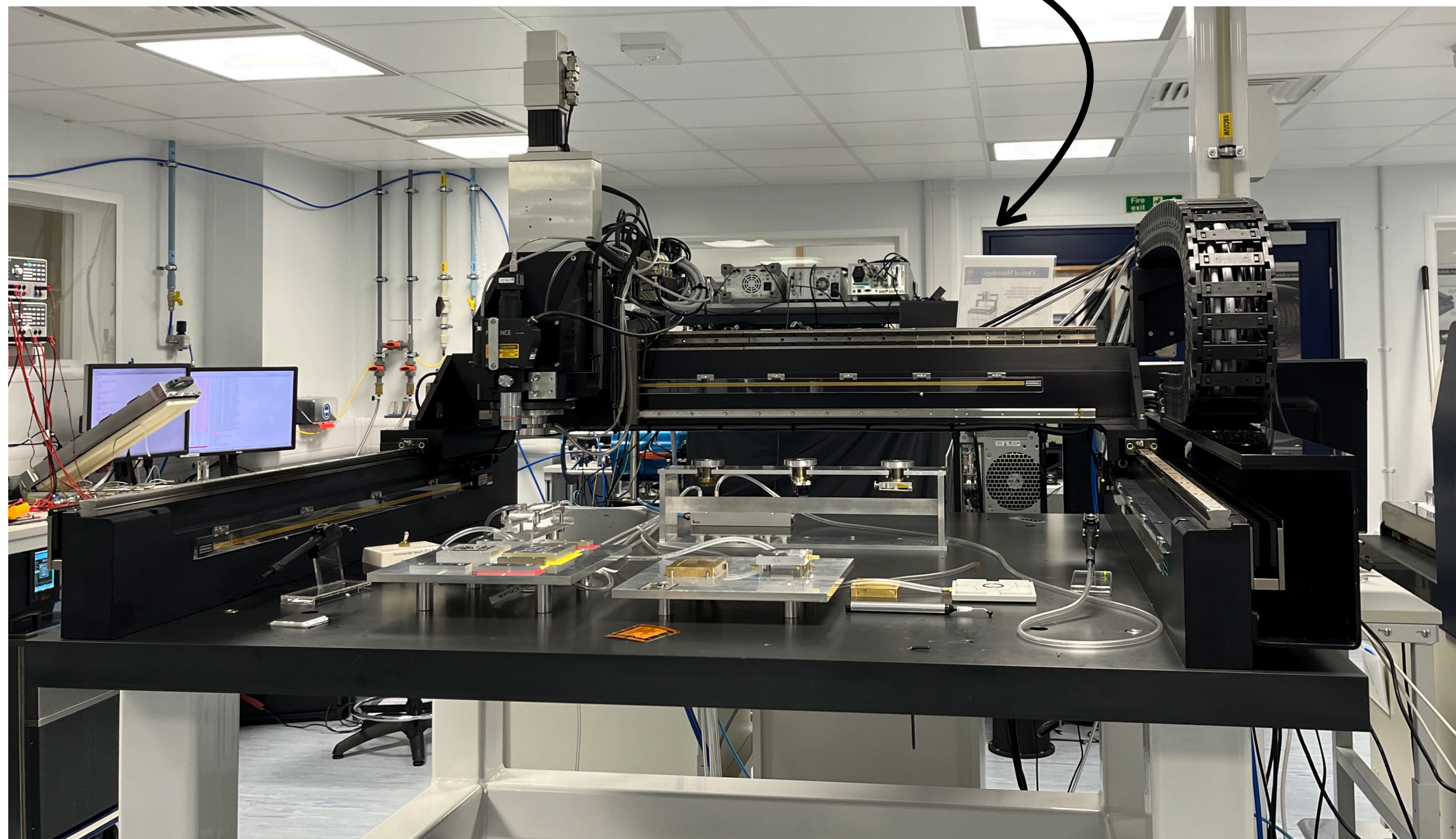

Glue-dispensing robot

- Allows for precise placement ( $15\ \mu\text{m}$ ) and size of glue deposits

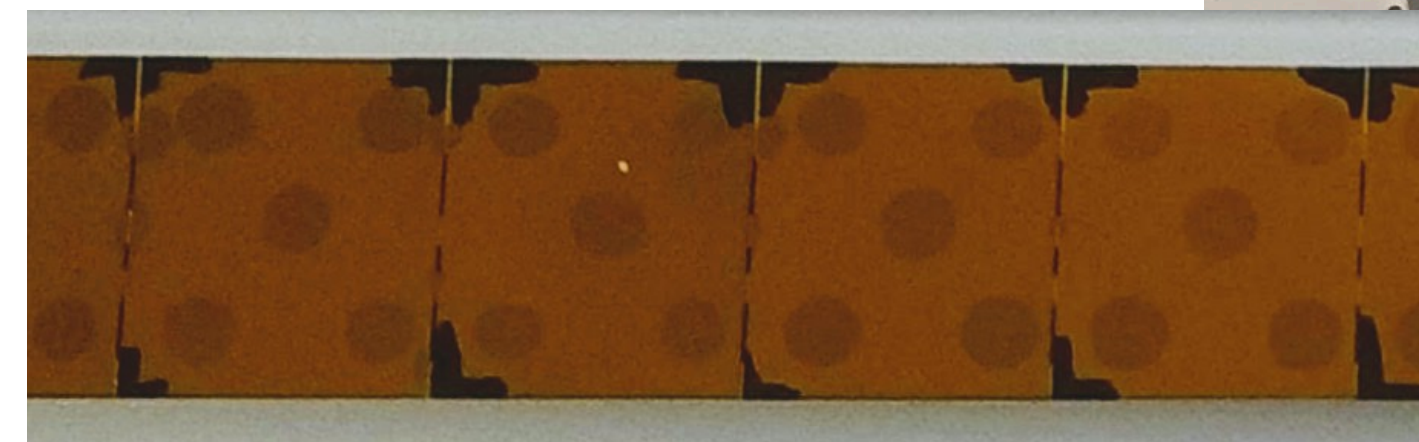
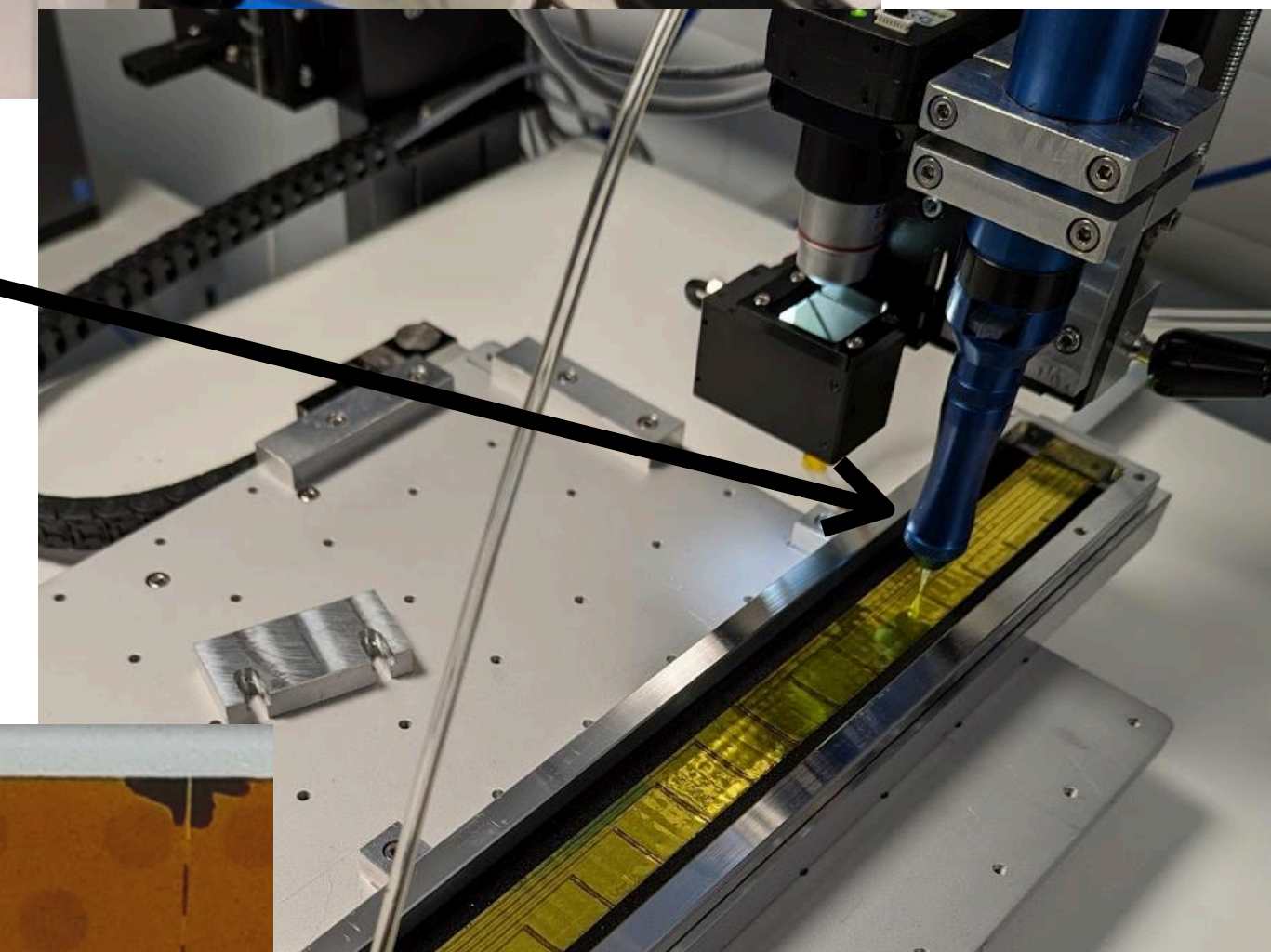

# Outer pixel layer production status:

Production tooling for Layer 4 is almost complete, tooling for Layer 3 to commence shortly after.

- Expected production rate is  $\mathcal{O}(1.5 \text{ ladders / day})$ , to commence March 2024

## Prototype outer pixel layers have been fabricated.

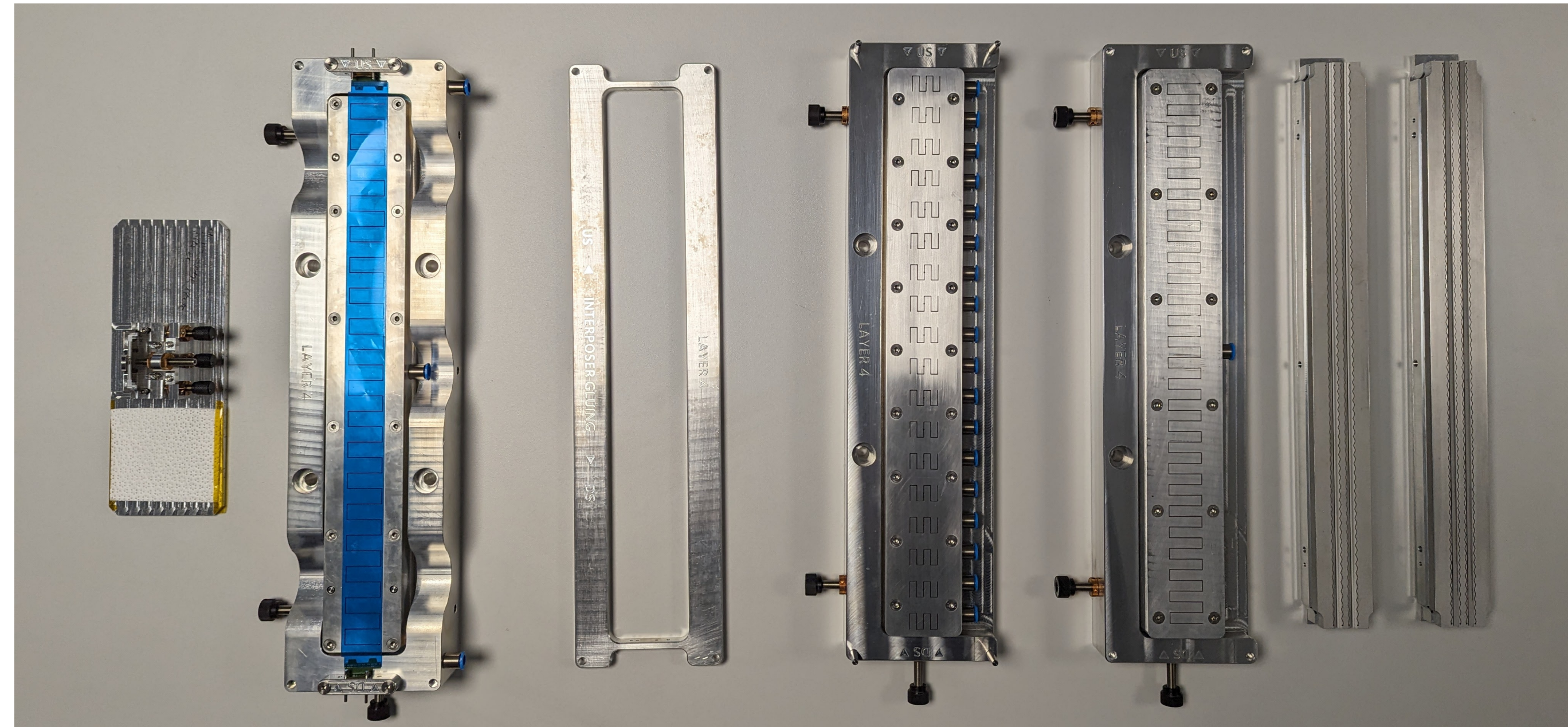
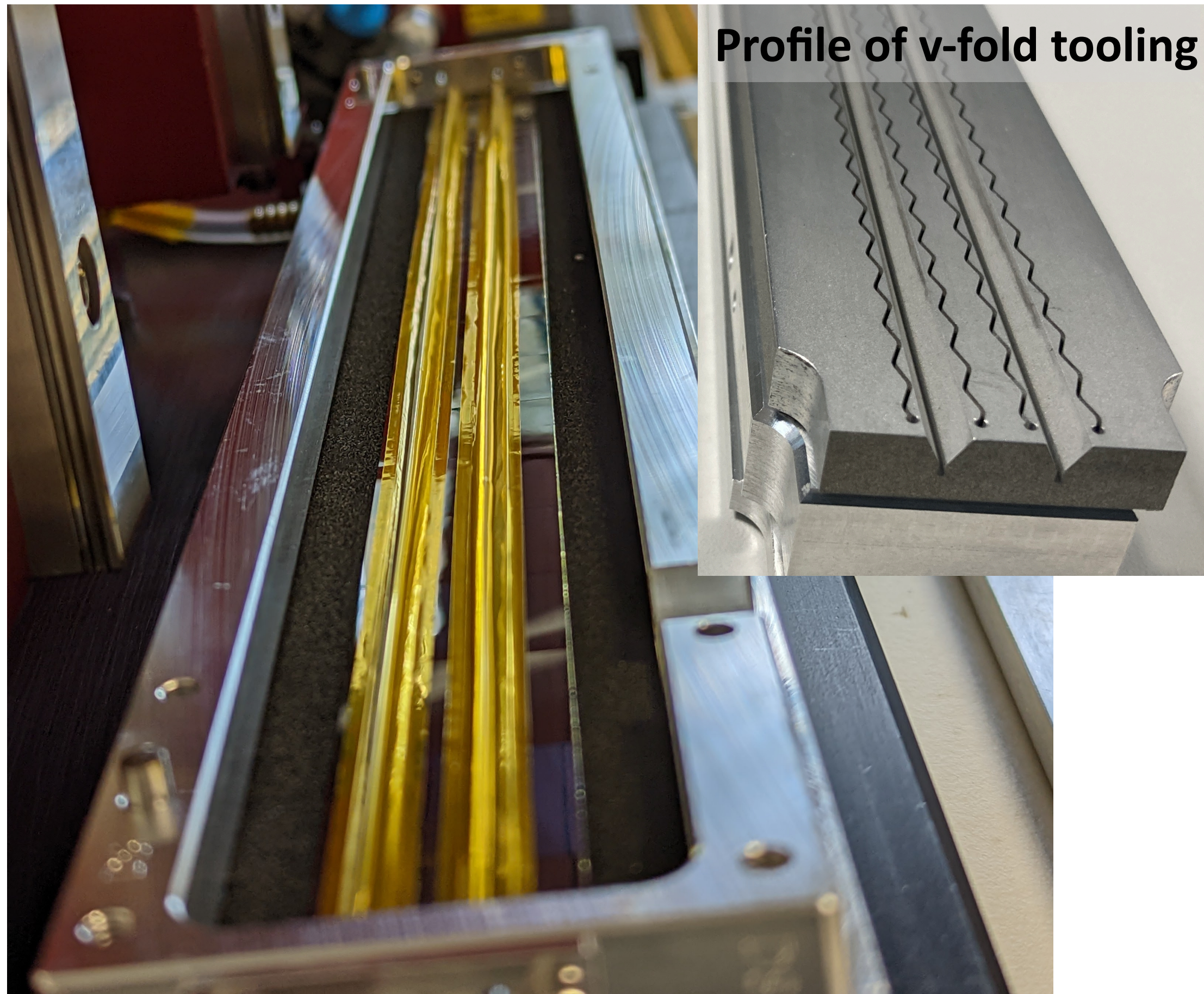

Interposer flex bending tool

Align, glue, TAB bond interposer and ladder flexes

Ring frame to hold ladder during production

Chip chuck: align MuPix 11 array on robot and glue chips to ladder

Flex chuck for MuPix11 TAB binding, and V-fold gluing

V-fold and U-fold chucks

V-folds initially proposed to be made from **kapton**

- Somewhat difficult to fabricate, if not properly glued will peel off ladder (difficulties in transportation?)
- Seem to provide enough structural integrity for 18 chip ladders, but not more (important for the future)

Alternate proposal: make **carbon-fibre u-folds**

- **Slightly lower mass than kapton**
- U-folds: rounded edge v-folds
  - Larger radius bend in carbon-fibre gives them greater mechanical stiffness versus Vs
- Much easier to manufacture and handle (transport)
- Potential concerns about electrical cross-talk

**Carbon-fibre ladder**  
Can hold 3 coins!



**Kapton ladder**

Visibly sags under it's own weight

**Each object with steel chips weighs ~ 5g,  
corresponding to  $\approx 2$  grams for Si chips!**

Test ladders made so far from 60 $\mu$ m thick uni-directional carbon-fibre, with joined u-folds:

- ATLAS pre-preg: Mitsubishi K13C2U and Cyanate Ester EX1515 matrix

Future:

- 30 $\mu$ m also available: tow spread Tairyfil TC33 fibre and SK Chemicals K51 matrix
- Ultimately **15 $\mu$ m thickness**: via informal contacts with Renault F1 thanks to our engineering team
- Likely combine with thin kapton backing (to ensure no electrical contact between ladder halves)

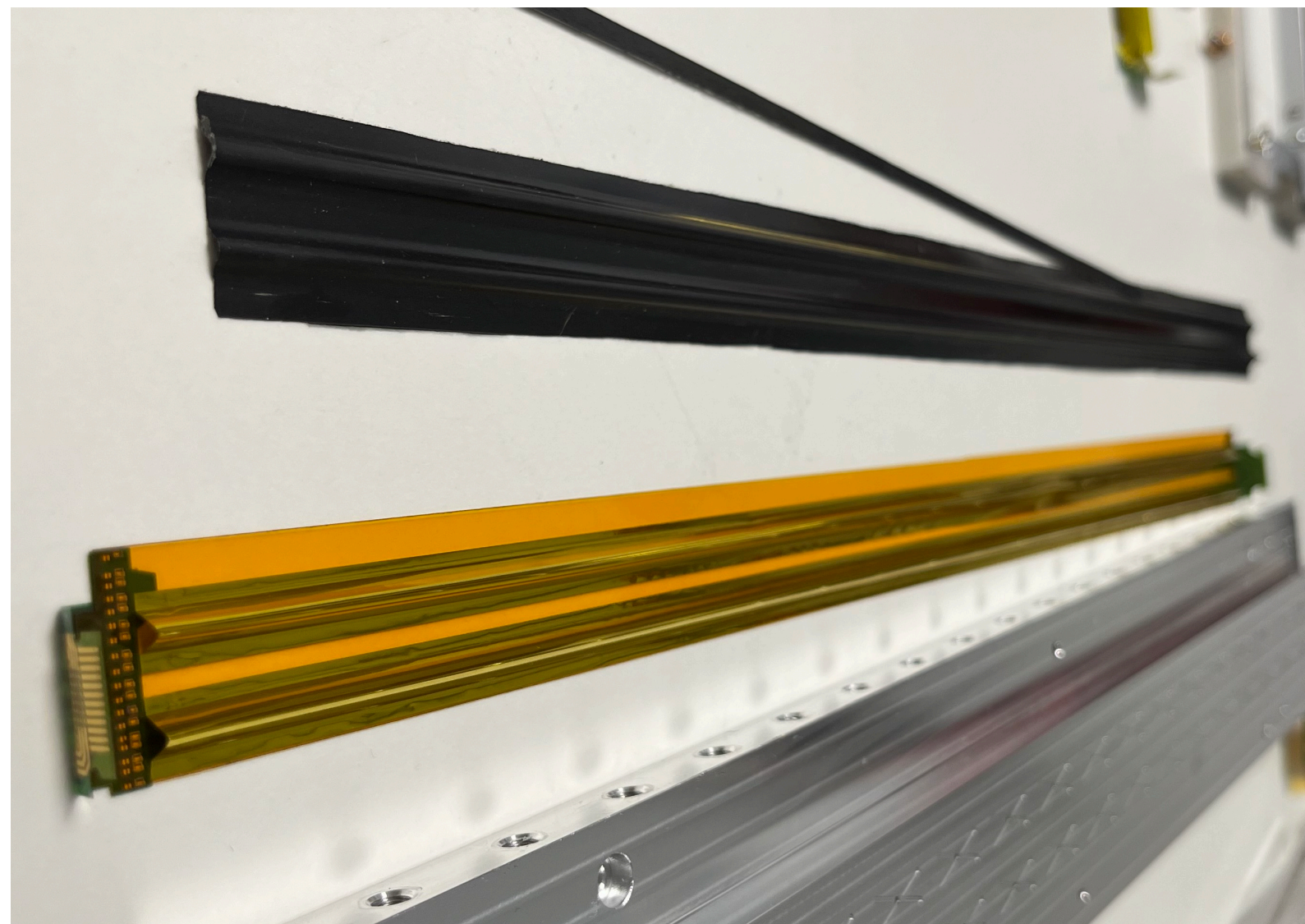

Construction on-going for **test ladder objects of both kapton and carbon-fibre**

- Production of carbon-fibre prototype ladders in progress: strong collaboration with mechanical workshop @ Oxford
- Perform mechanical and electrical tests on both





First test of **electrical connectivity**: using ladders made with silicon heaters

- LEDs soldered to monitor in real-time the connectivity of the 4 sense (green) + power (red) lines per chip
- Thermal cycle between expected operational temperature range ( $0 \rightarrow 60^\circ\text{C}$ ) to check for failures

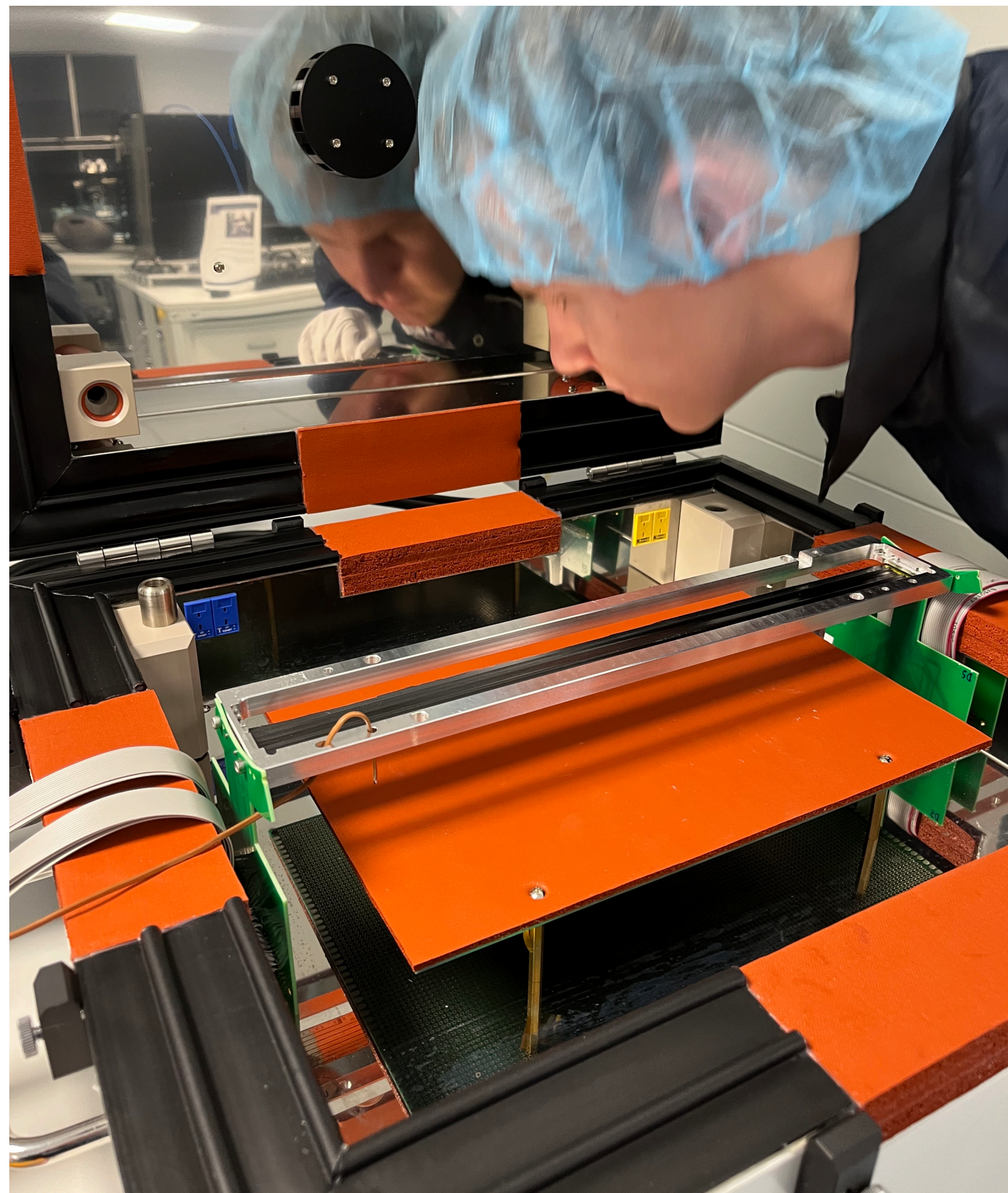

Thermally insulated box

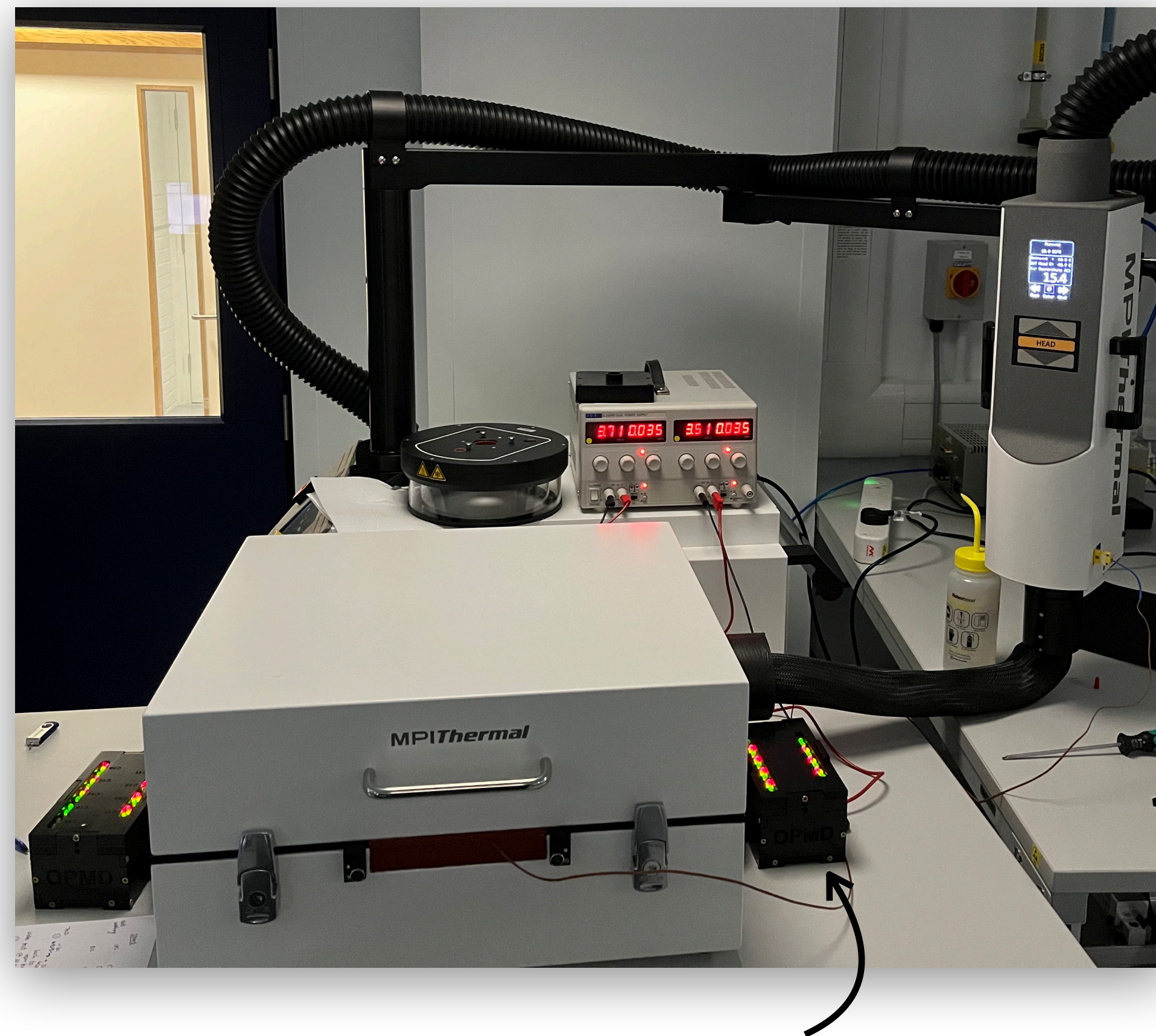

Thermal cycling system, LEDs remain outside

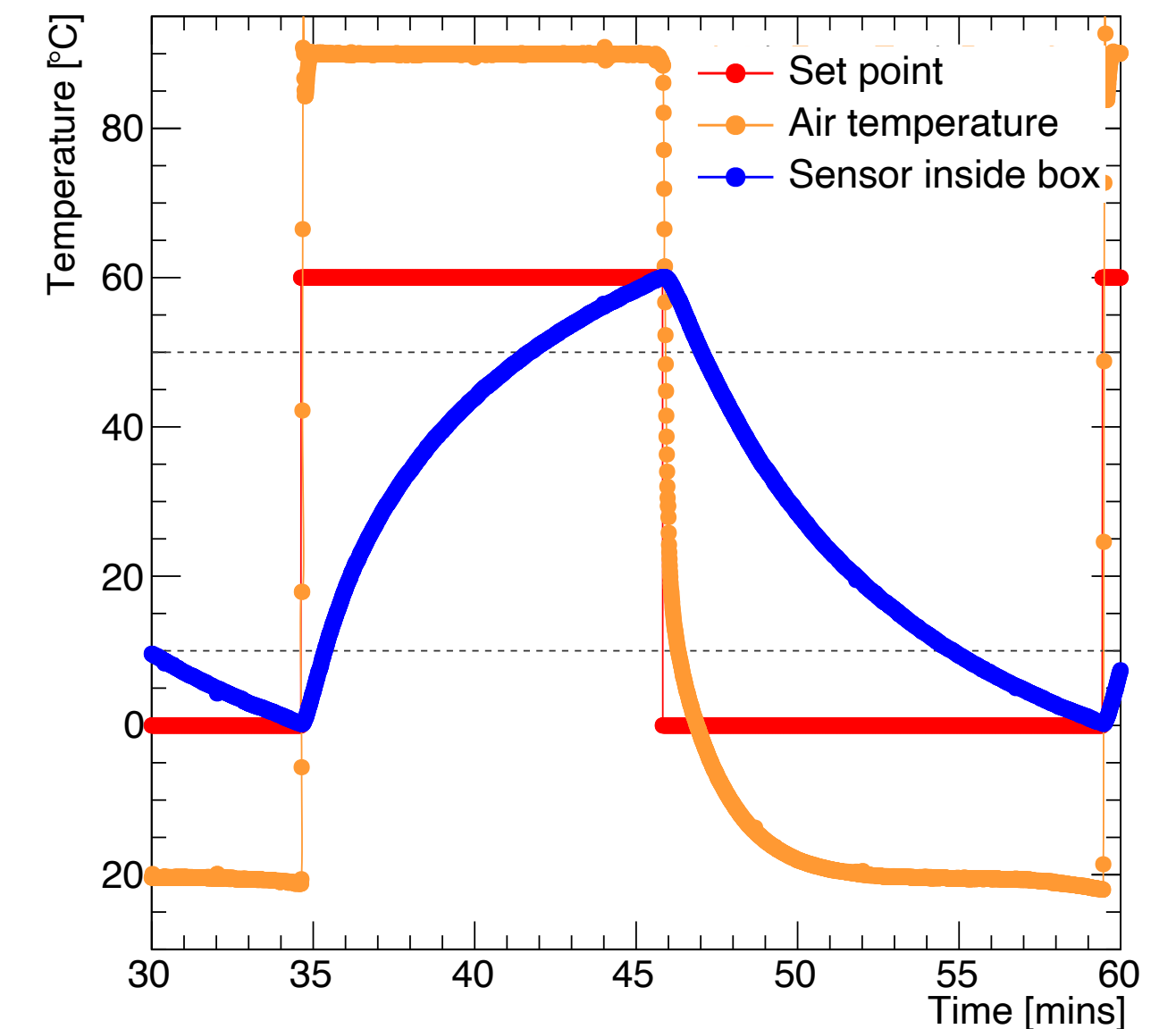

**50 cycles completed:**

- 2 failures seen (initially poor connections)

Now extended  $\Delta T = -20 \rightarrow 60^\circ\text{C}$

- Same test for kapton v-fold ladder in progress

# Quality control for silicon pixel chips:

A. McDougall



Use semi-automatic probe station @ Oxford to conduct QC tests on all pixel chips required for construction of outer pixel system.

**Single-chip testing:** establish QC procedure

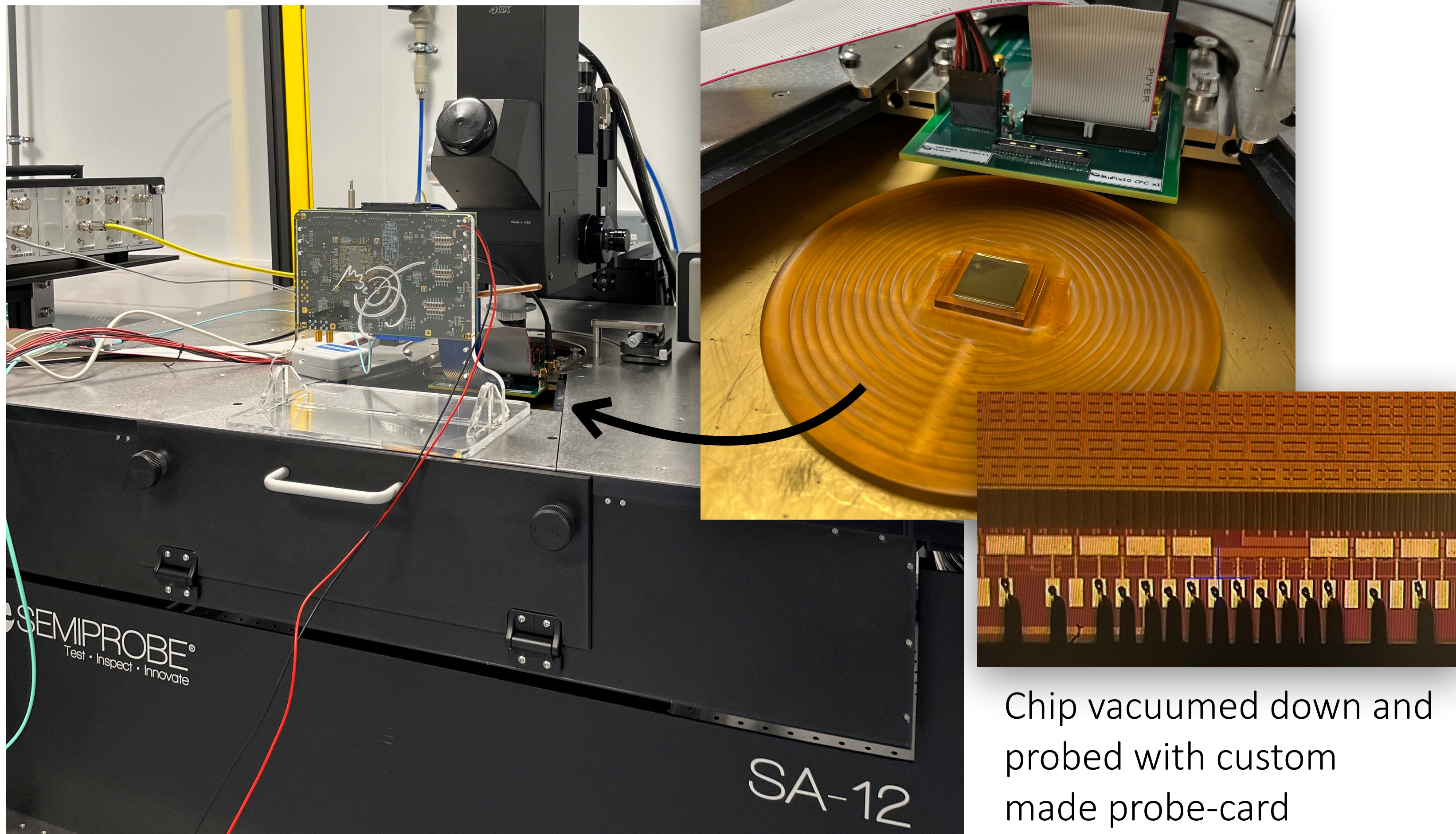

Chip vacuumed down and probed with custom made probe-card

**Wafer testing:** required for ladder production

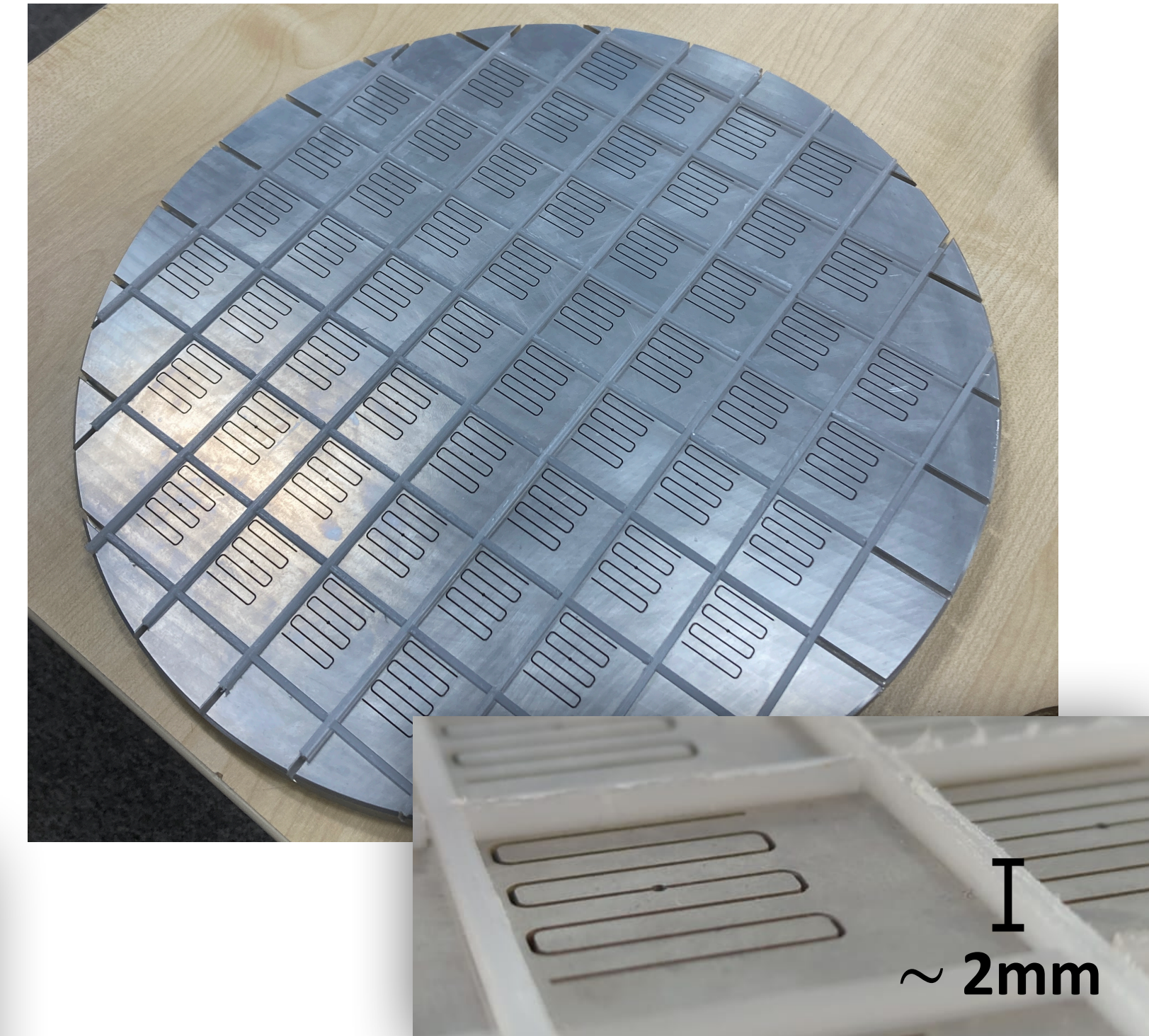

- Chips held with vacuum individually
- Raised edges allow for chip alignment
- Use pattern recognition to identify individual chips and low to pre-set height to make needle contact
  - Conduct QC tests

## **Mu3e: search for cLFV - aiming to measure the $BR(\mu \rightarrow eee)$ with unprecedented sensitivity!**

- Ultra light-weight detector using custom designed HV-MAPS pixel sensors (MuPix11) for the inner and outer pixel layers, to detect electrons and positrons
- MuPix chip development at the forefront of HV-CMOS R&D

Detector construction in progress:

- Expected full Mu3e detector integration + commissioning to take place mid 2024

## **Expected to start taking physics data in 2025 (Phase I):**

- Beam available until  $\sim$  end 2026  $\rightarrow$  shutdown ( $\rightarrow$  Phase II)
- Plans to upgrade existing muon beam to increase intensity
- High intensity muon beam (HiMB) project is under discussion
  - Would provide muon intensities  $> 10^9 \mu/s$
  - Ultimate experimental sensitivity limited by this rate

*Stay tuned ... !*

