



Simulation based investigation on the influence of electromagnetic power in VBD initiation process

Tauno Tiirats

A. Kyritsakis, R. Koitermaa, V. Zadin

Tartu University, Institute of Technology

ERA Chair MATTER

MATTER



Outline

MATTER

- **Introduction**
- **Electromagnetic power flow & simulations**
 - Idea
 - Implementation
 - FEMOCS
 - BDMC
 - Preliminary results
- **Conclusion**

- **VBD mitigation techniques:**
 - Controlling relevant characteristics
 - (electric field, surface roughness, contamination)
 - **Limiting the available EM power** [1,2]
- The hypotheses:
 - **The power supply limitation hinders the development of plasma exactly at the moment plasma initiates** (stage 2-3)
- **The goal:**
 - Describe quantitatively the **EM power dependence of VBD initiation**

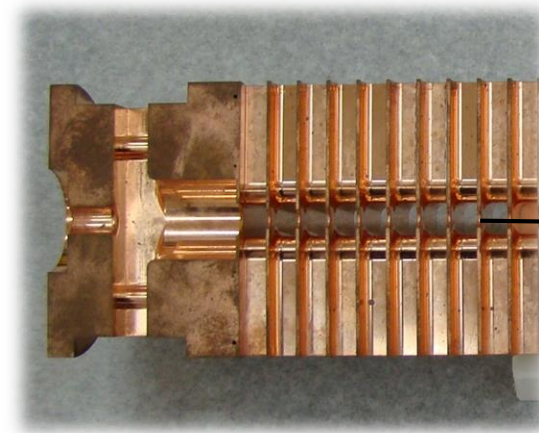

Accelerating structure (CLIC)

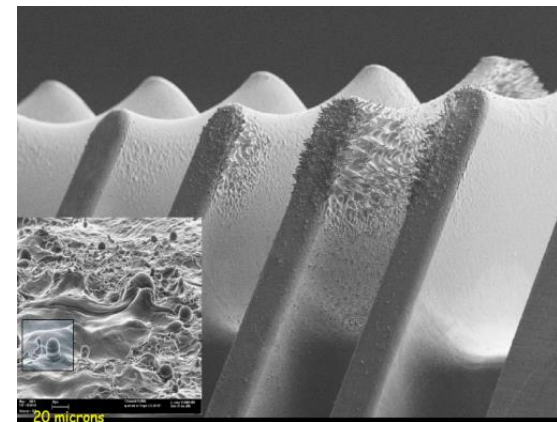
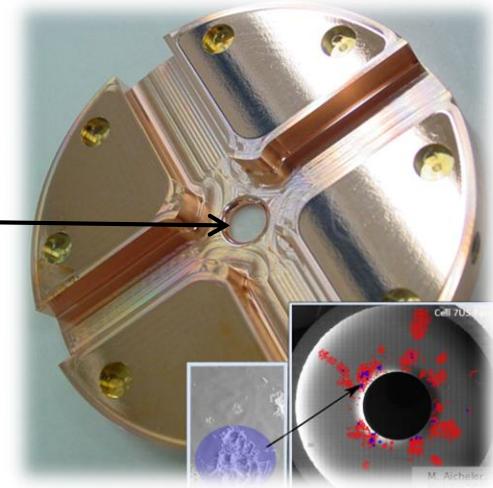

Surface damage in CLIC accelerating structures after the breakdown

Images: Walter Wuensch, CERN

[1] W. Wuensch. The Scaling of the Traveling-Wave RF Breakdown Limit. Technical Report CERN-AB-2006-013. CLIC-Note-649, CERN, Geneva, Jan 2006.

[2] A. Grudiev, S. Calatroni, and W. Wuensch. New local field quantity describing the high gradient limit of accelerating structures. Phys. Rev. ST Accel. Beams, 12:102001, Oct 2009.

Electromagnetic power supply

MATTER

- „Experimental data (CERN, SLAC and KEK) suggests High-Gradient limit depends on power flow, not only E field“ [3]
 - **Plasma initiation requires a large influx of power**
- **Ultimate VBD limit is a function of available power**
 - During VBD onset!
 - **Local power flow**
 - Local surface E field decreases under VBD loading

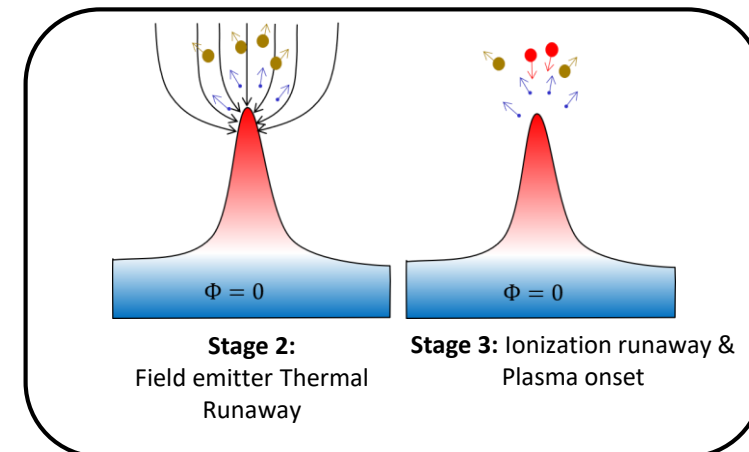
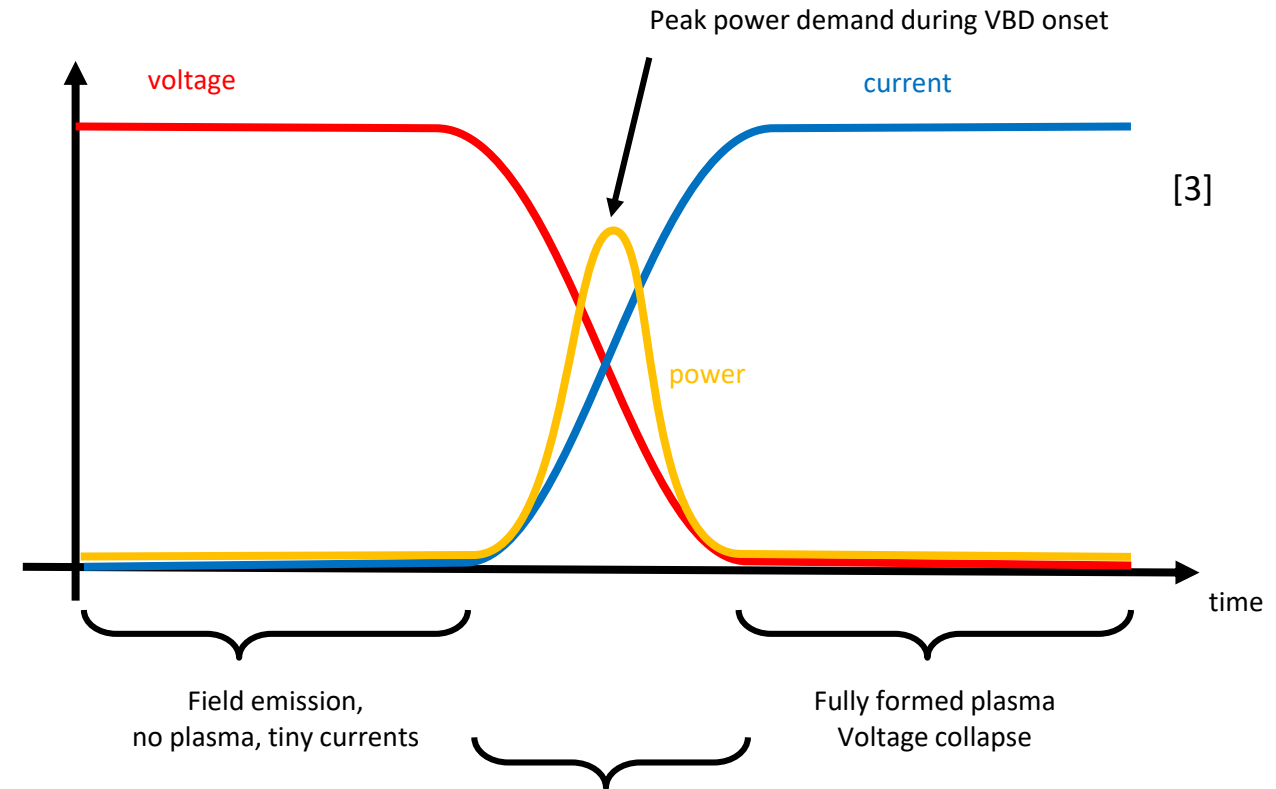

[3] J. Paszkiewicz, A. Grudiev, and W. Wuensch. Breakdown-loaded electric field as a high gradient limit. 2019 International Workshop on Mechanisms of Vacuum Arcs (MeVAarc), 2019.

Investigation strategy

MATTER

Multi-scale physics
FEMOCS

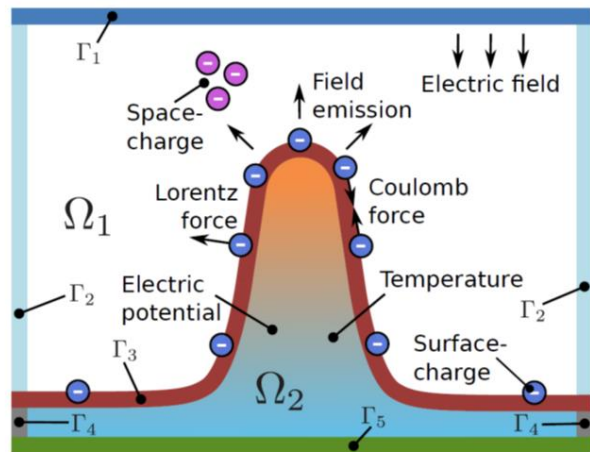

Image: Mihkel Veske, UH&UT

Real measurements & statistics
BDMC

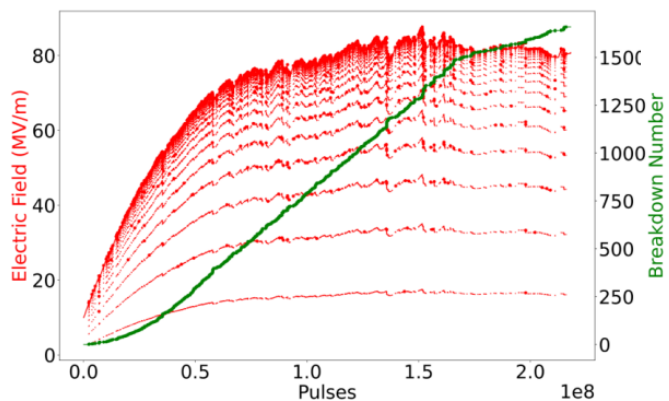

Image: Victoria M. Bjelland, CERN





MATTER

Multi-scale simulations

FEMOCS

Multiscale breakdown simulations

MATTER

- VBD involves **various phenomena in various space scales**:
 - Emission spot formation
 - **Thermal runaway**
 - **Field emission**
 - **Plasma formation**
 - Surface damage

- Need for concurrent, **multi-scale, multi-physics simulations**
 - **Atomistic simulations**
 - Molecular Dynamics (MD)
 - Particle Dynamics (PIC)
 - **Continuum simulations**
 - Thermomechanics (FEM)
 - Electromagnetics (FEM)

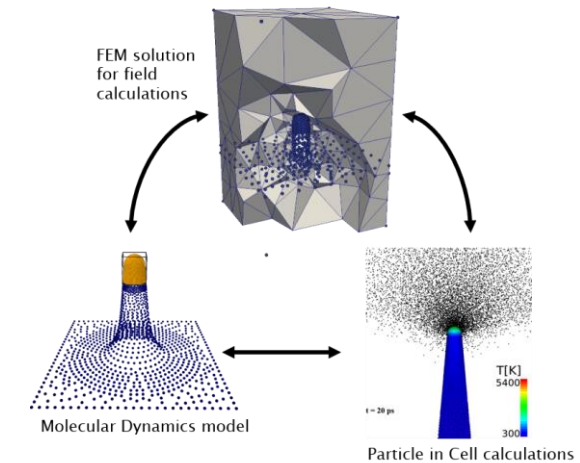
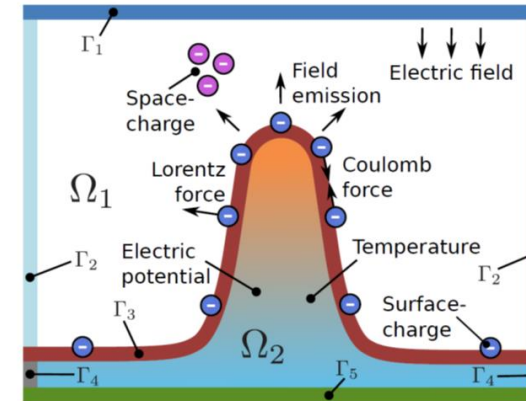

FEMOCS (gitlab.ut.ee/matter/femocs)

MATTER

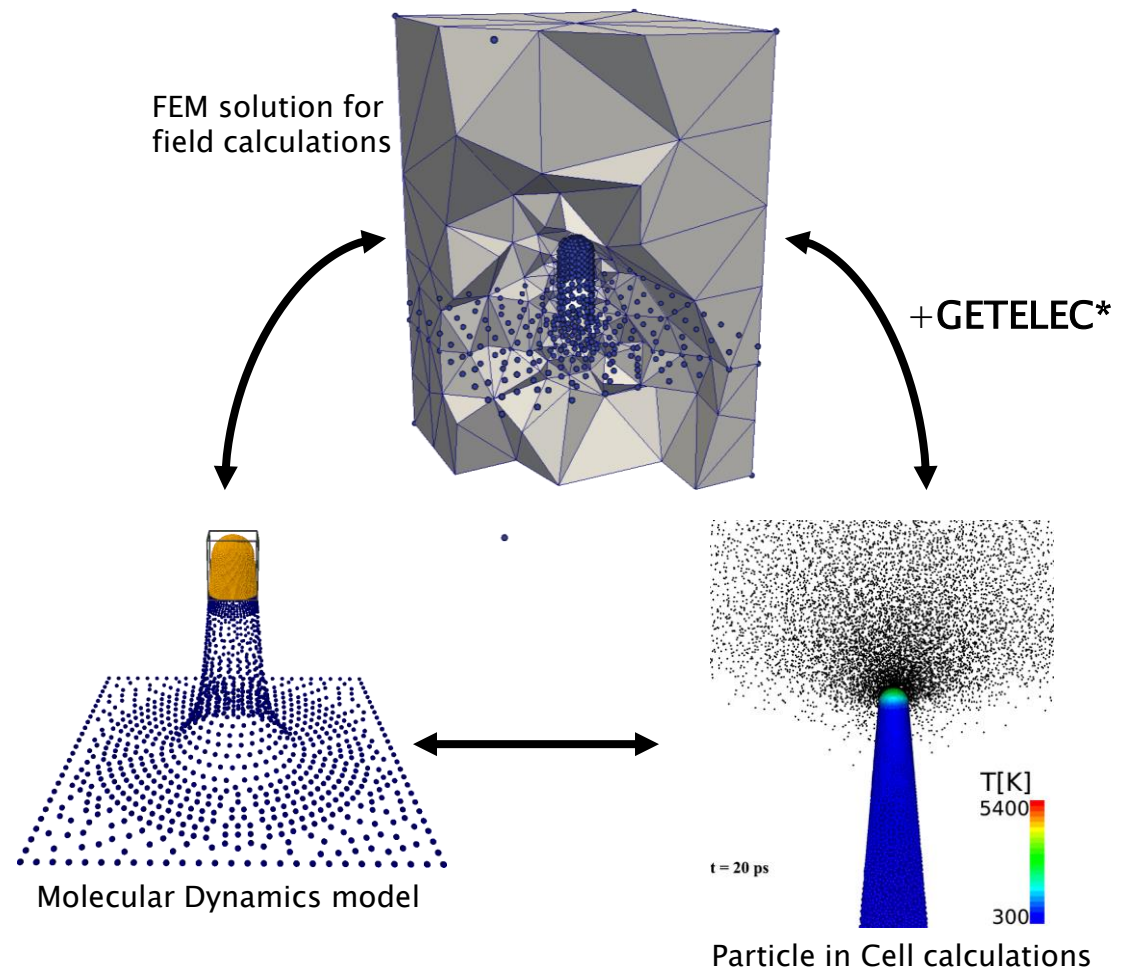

* Version 3 soon to be published: gitlab.ut.ee/matter/getelec

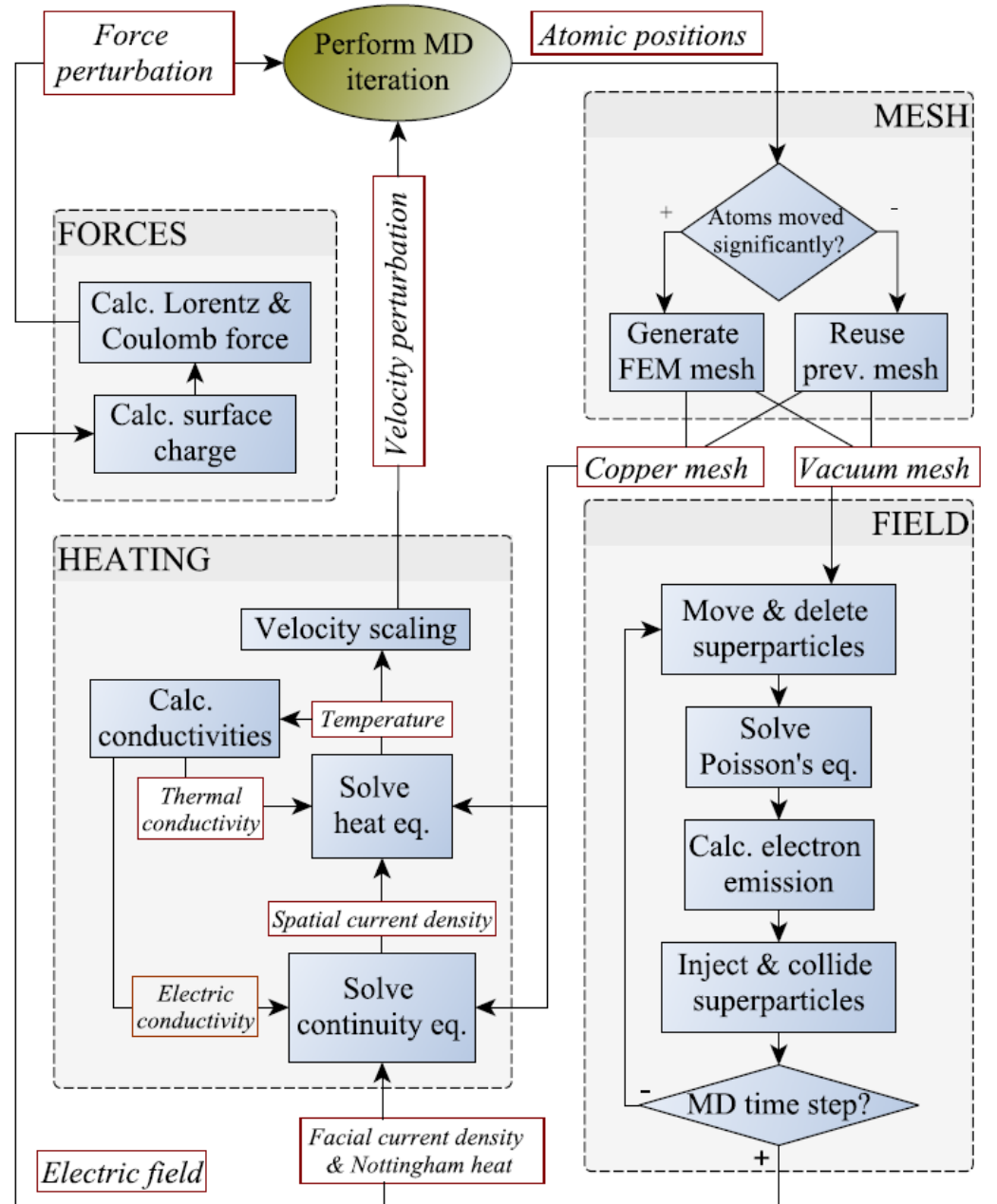

- **Jan Paszkiewicz's solution** [4]:

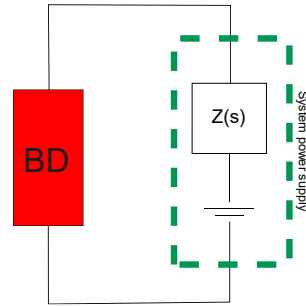

- Simplified circuit
- VBD dynamics approximated by a "simple" non-linear circuit element (*Child-Langmuir law*)
- For **any point** in the domain evaluate:
 - **dependence of local field on test current**
 - **assumed function** for VBD site emitted current
 - Find quasi-equilibrium point

- **Elegant, but ...**

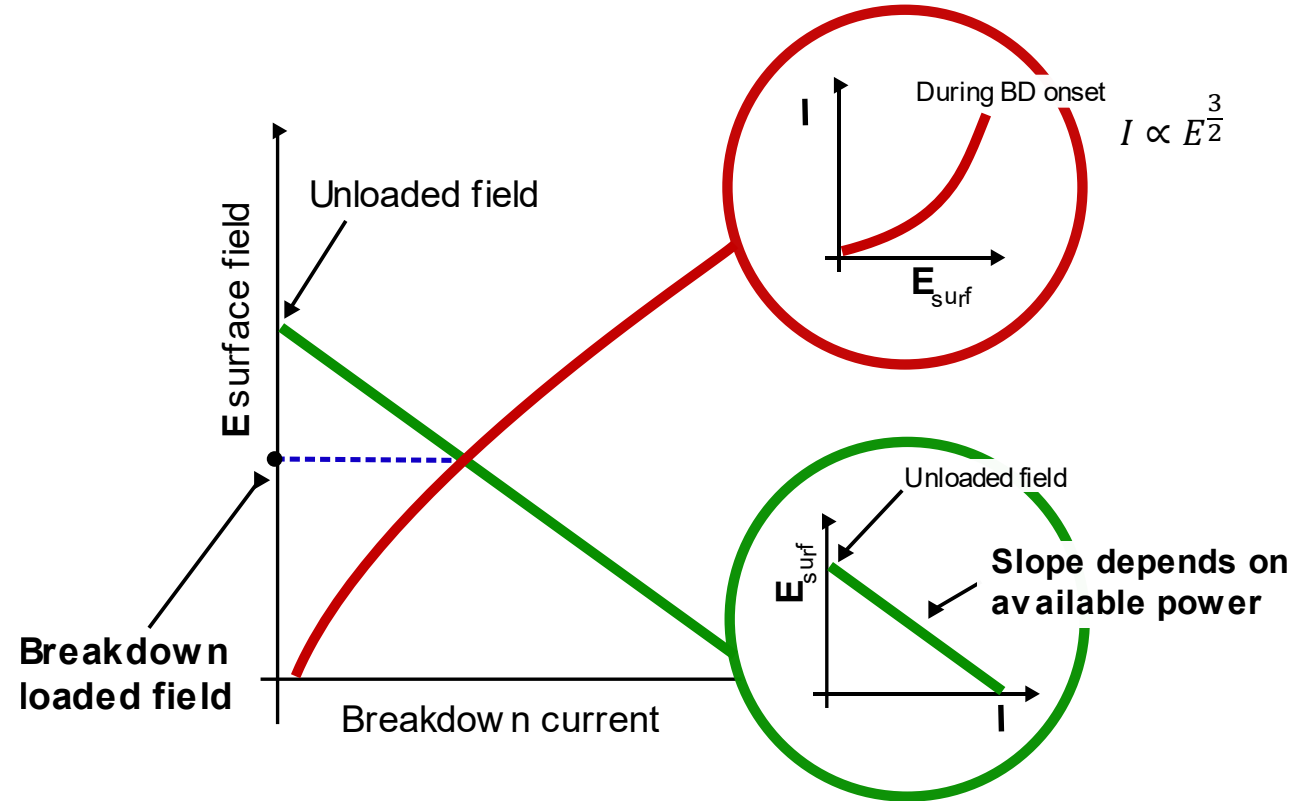

[4] Paszkiewicz, Jan. *Studies of breakdown and pre-breakdown phenomena in high-gradient accelerating structures*. Diss. University of Oxford, 2020.

- **Jan Paszkiewicz's solution:**

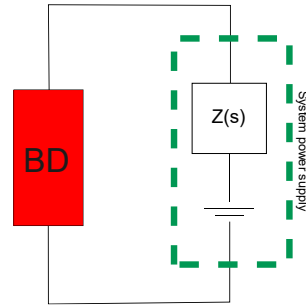

- Simplified circuit
- VBD dynamics approximated by a "simple" non-linear circuit element (*Child-Langmuir law*)
- For **any point** in the domain evaluate:
 - **dependence of local field on test current**
 - **assumed function** for VBD site emitted current
 - Find quasi-equilibrium point

- **DOES NOT ACCOUNT FOR THE FULL PHYSICS OF VBD!!!**

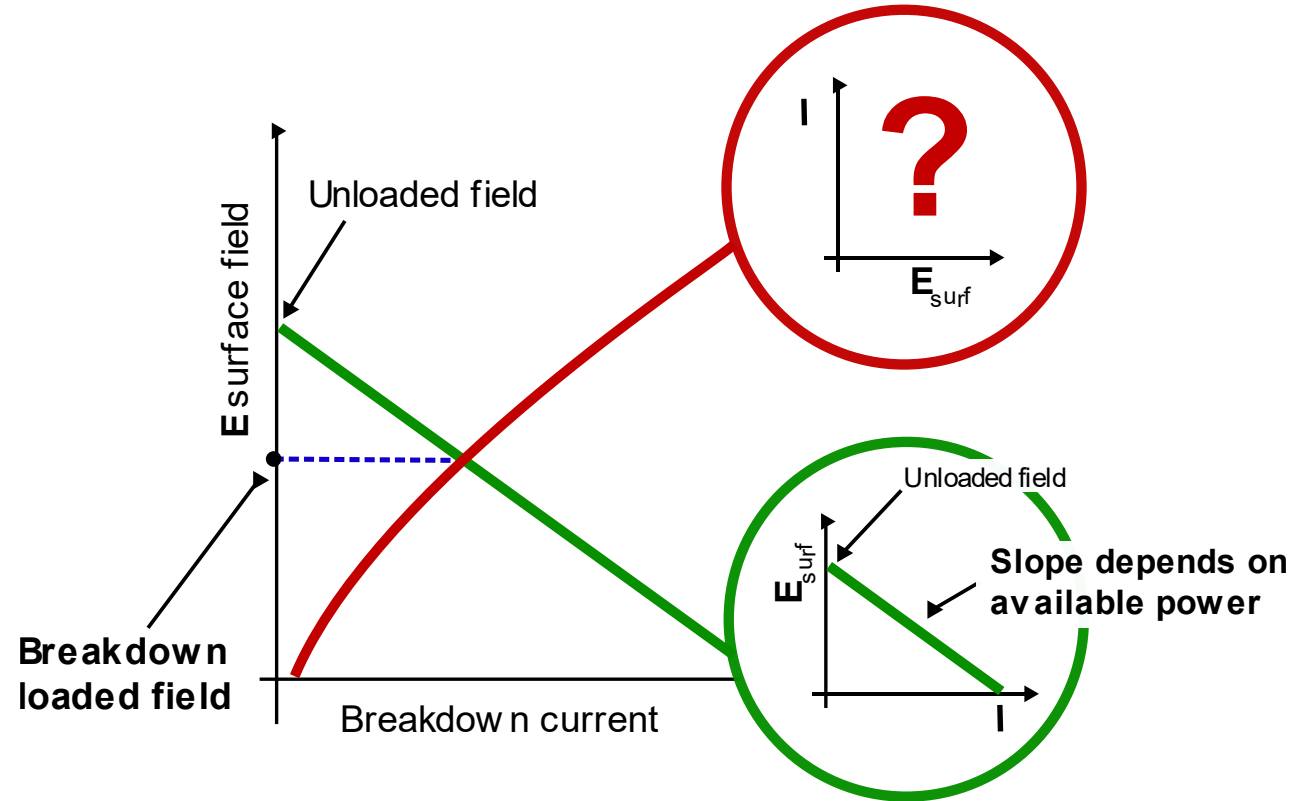

- **FEMOCS to the rescue**
 - Evaluate the local VBD physics accurately
- **Couple the whole system to the VBD**
 - Via impedance $Z(s)$ (*Thevenin theorem*)
 - At any point in the system
- V_{sim} as the coupling link:
 - $V_{sim}(s) = V(s) - I(s)Z(s)$
with Reverse Laplace transform:
 $v_{sim}(t) = v(t) - i(t) * \zeta(t)$ *Impulse response*
- $Z(s)$ as the **system design parameter**
 - Each point has an unique impulse response

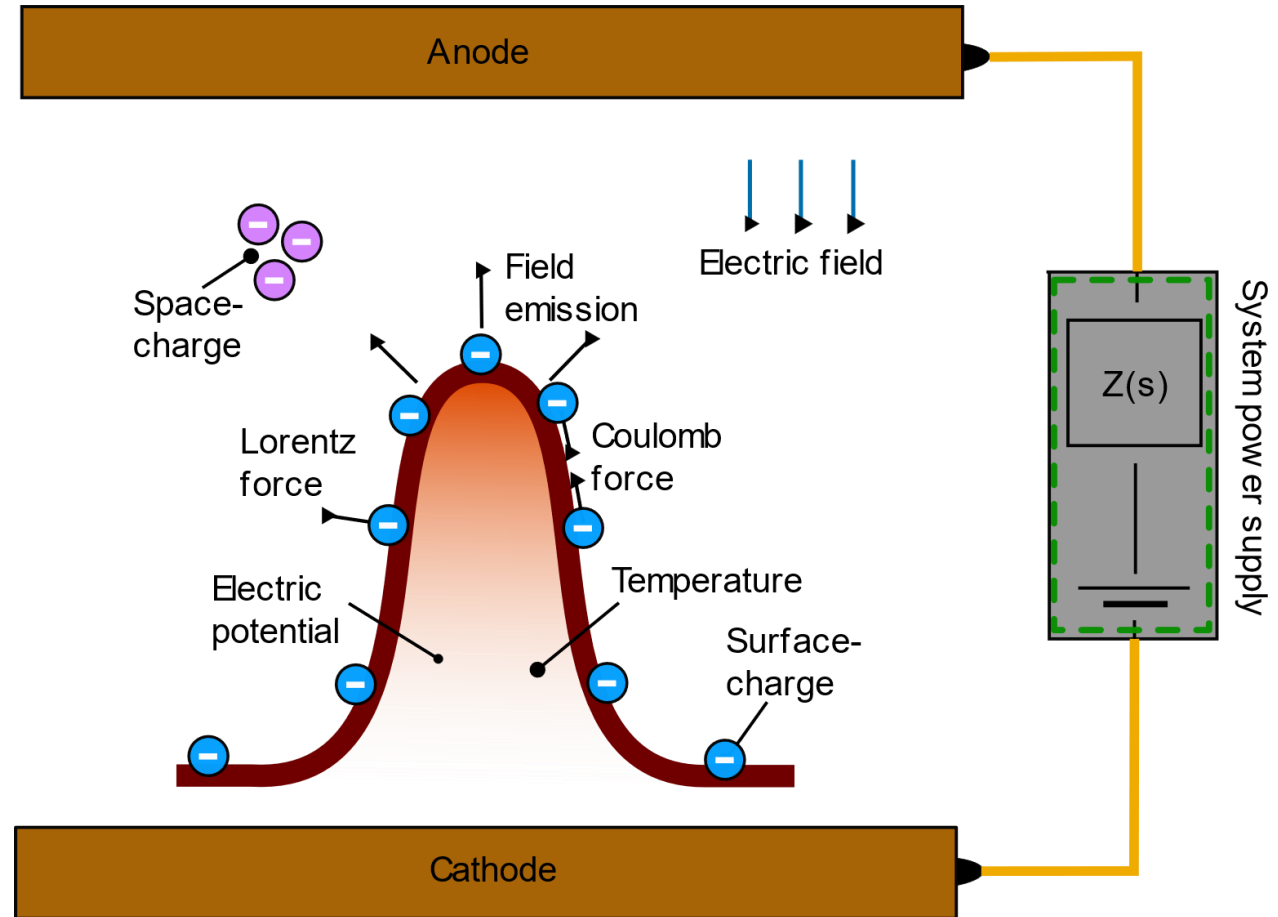

VBD initiation example

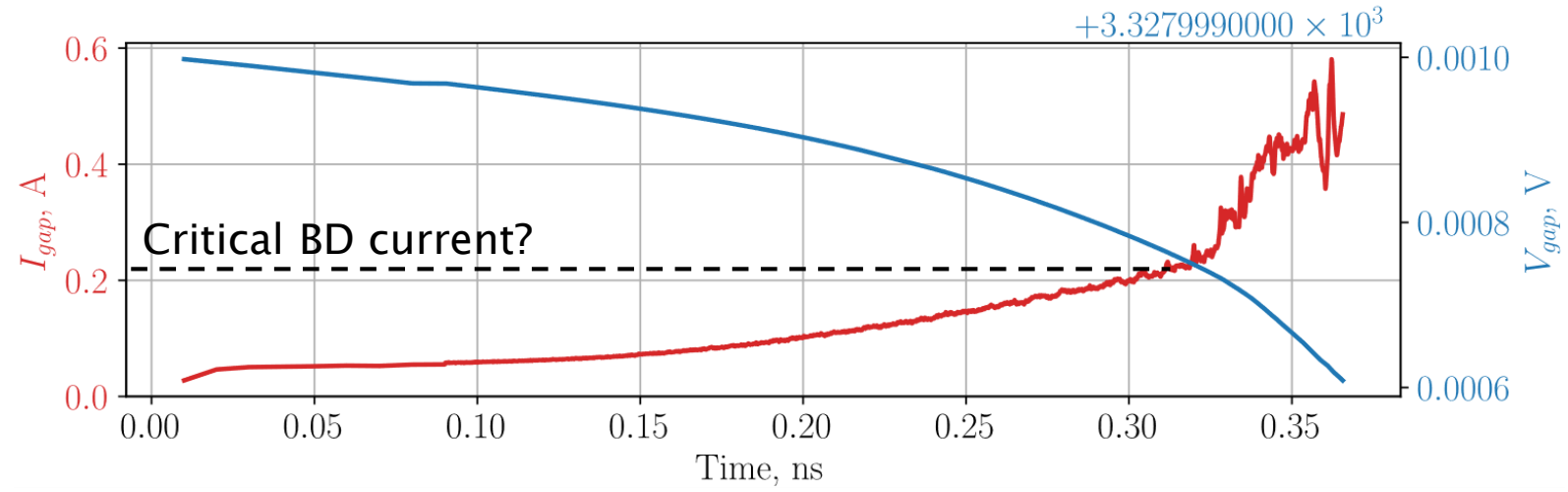

- Electrons
- Neutrals
- Ions

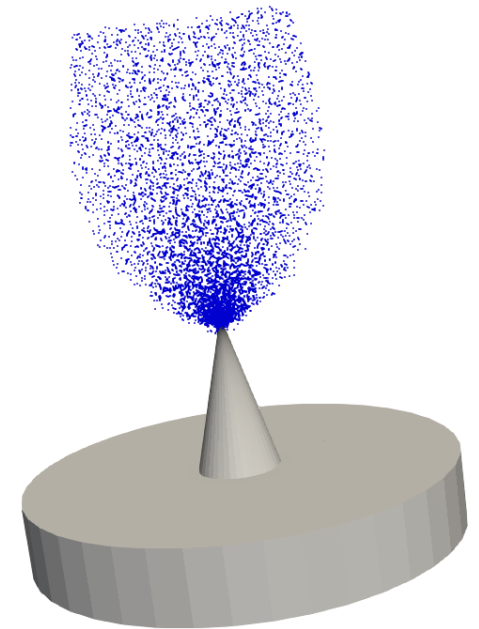
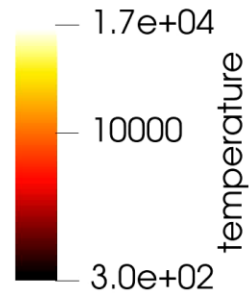

R circuit case study

MATTER

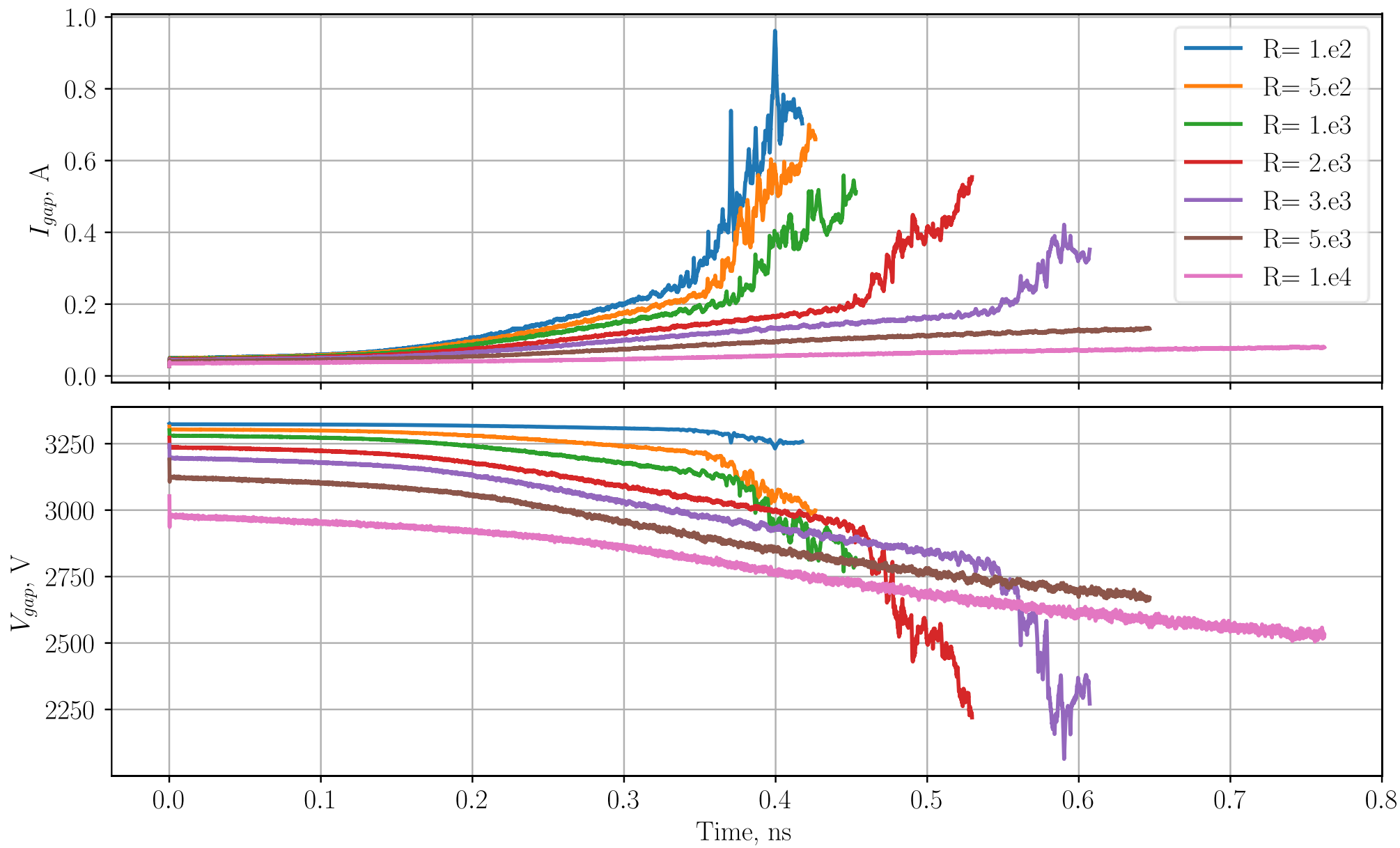

DC Large Electrode system

MATTER

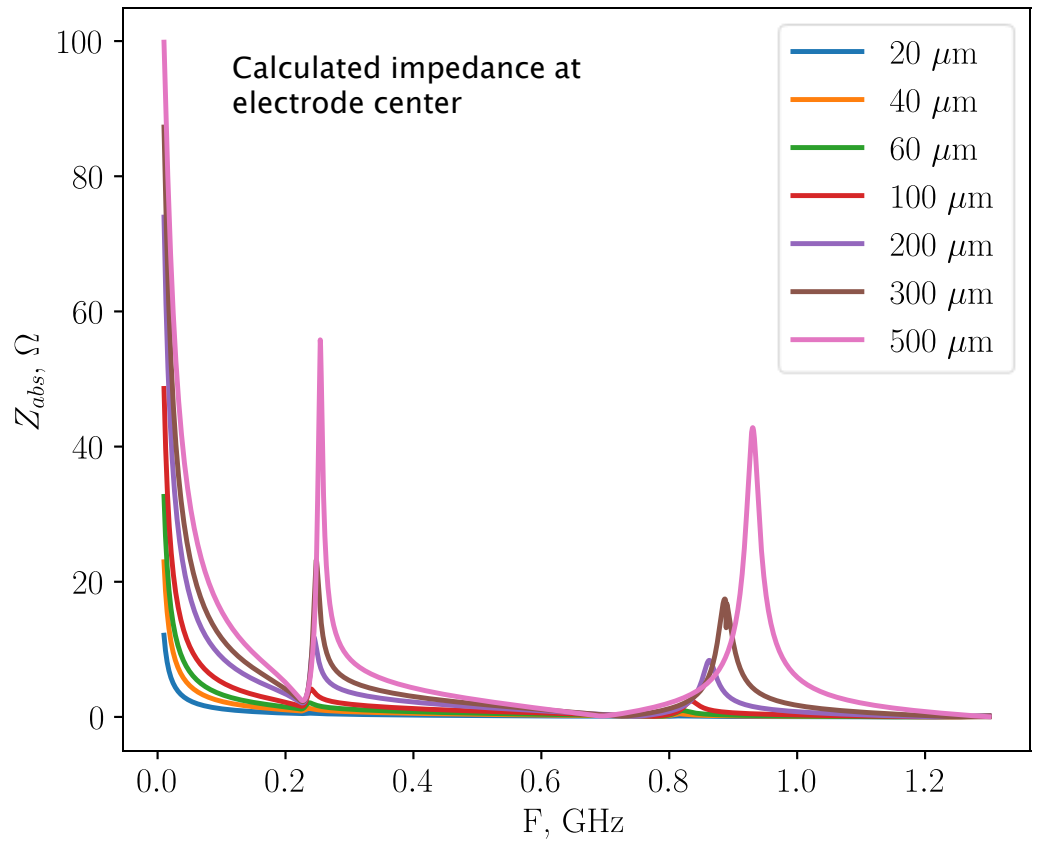

Data by: Jan Paszkiewicz, CERN

Soft Cu electrode. Image: Saressalo

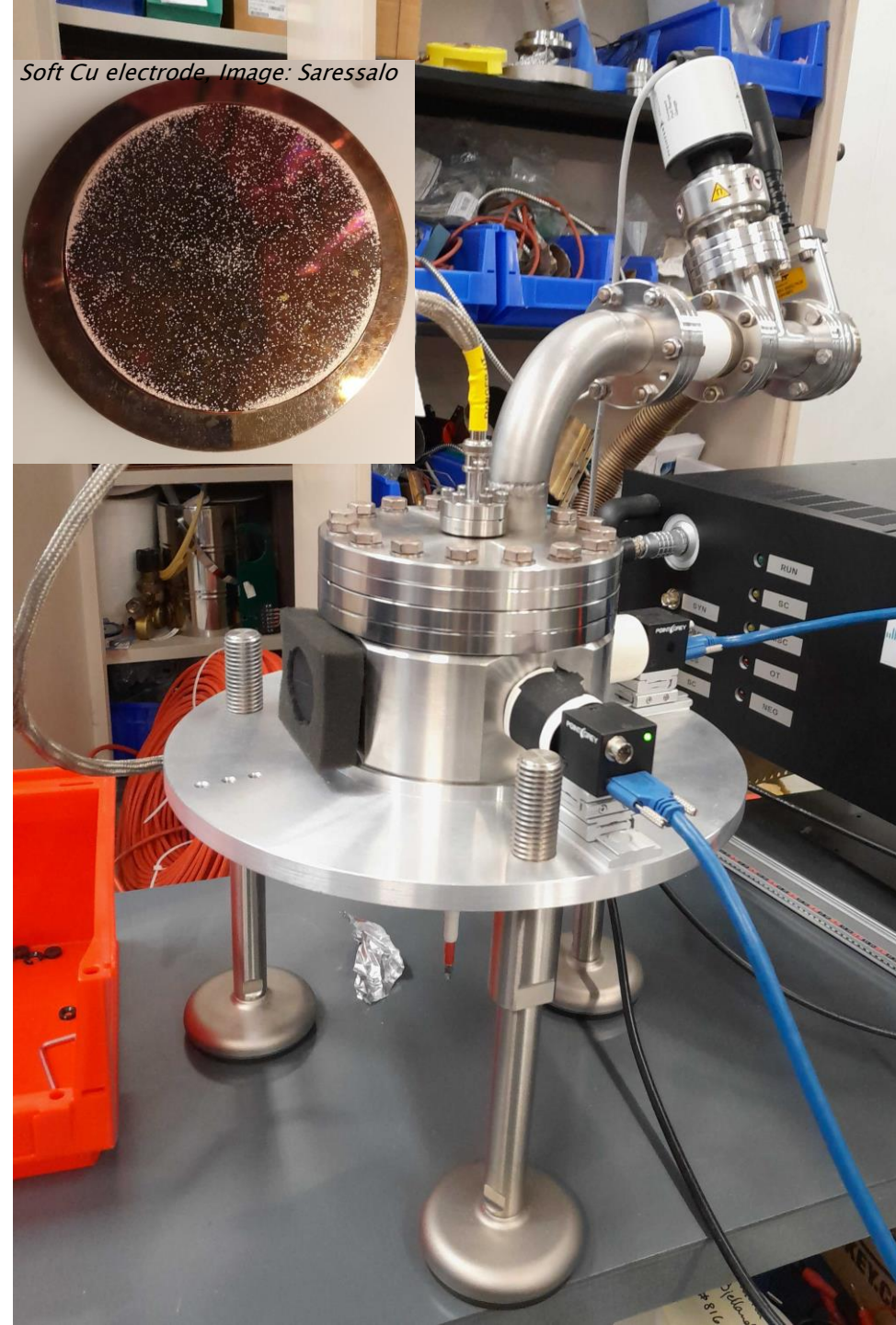

DC Large Electrode system

MATTER

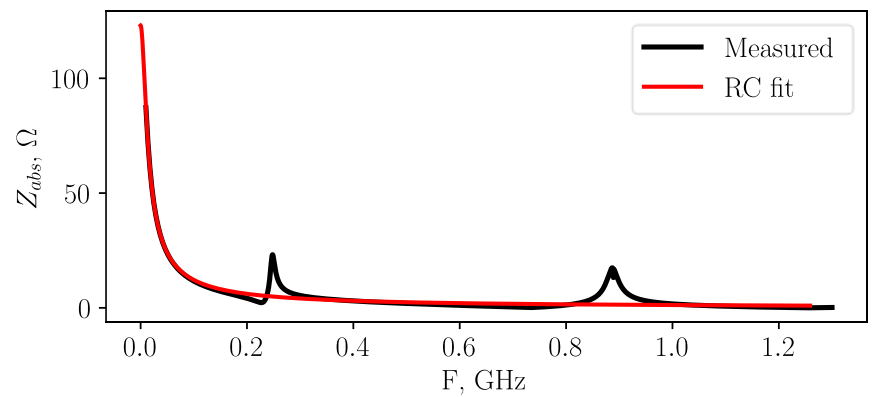
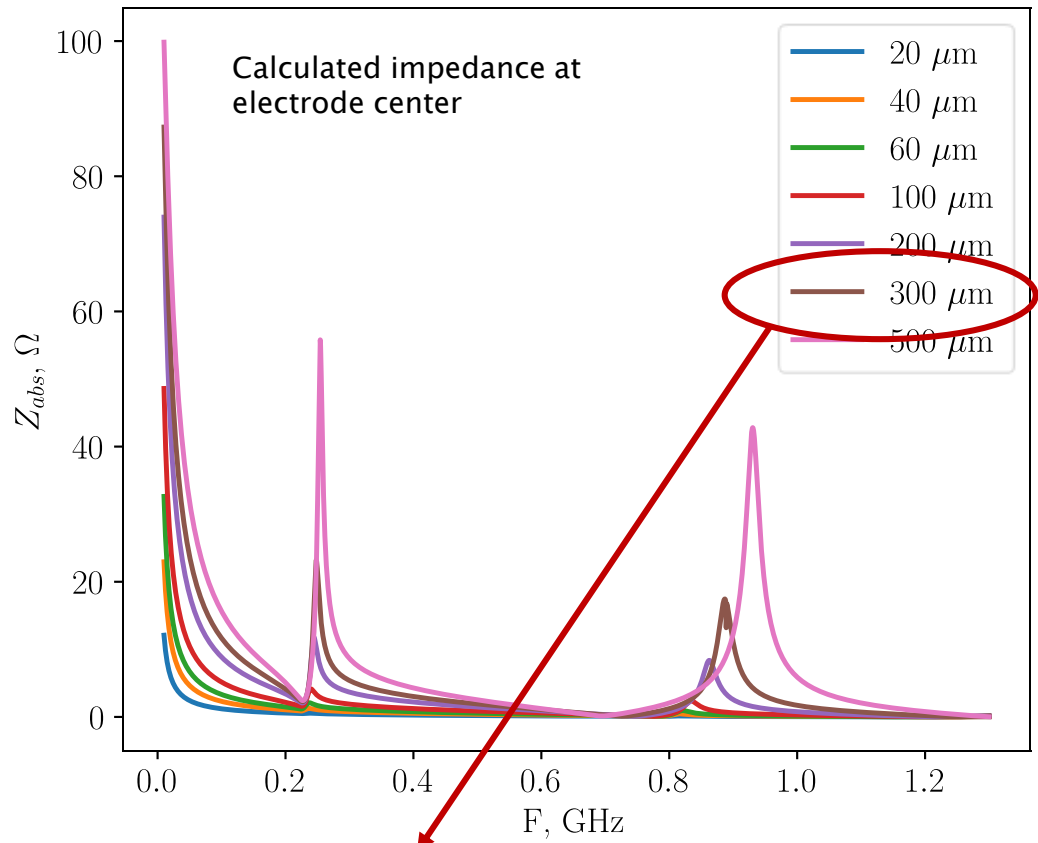

Data by: Jan Paszkiewicz, CERN

Soft Cu electrode. Image: Saressalo

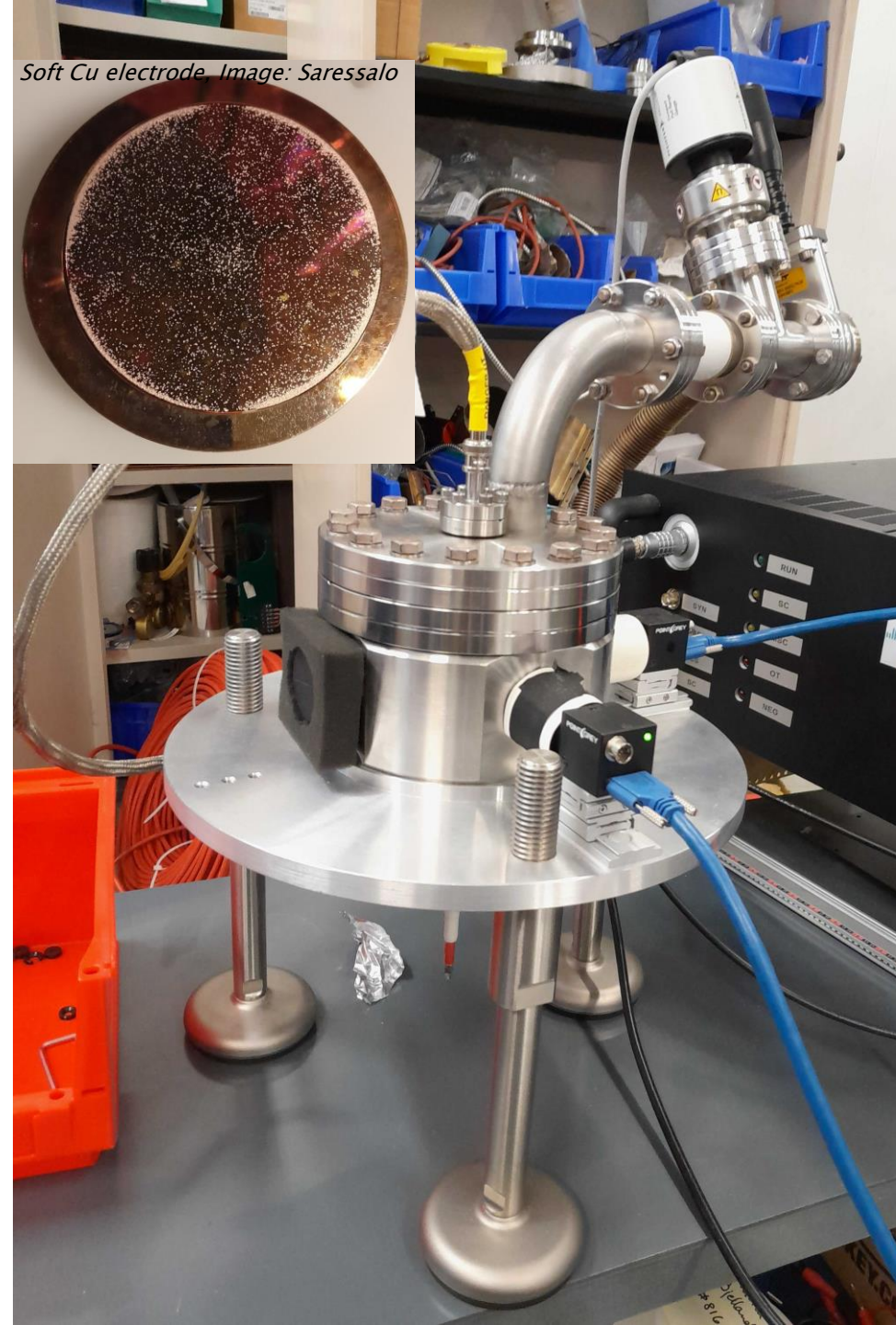

Preliminary LES simulation results $\leftarrow H = 2.5 \mu\text{m}$

MATTER

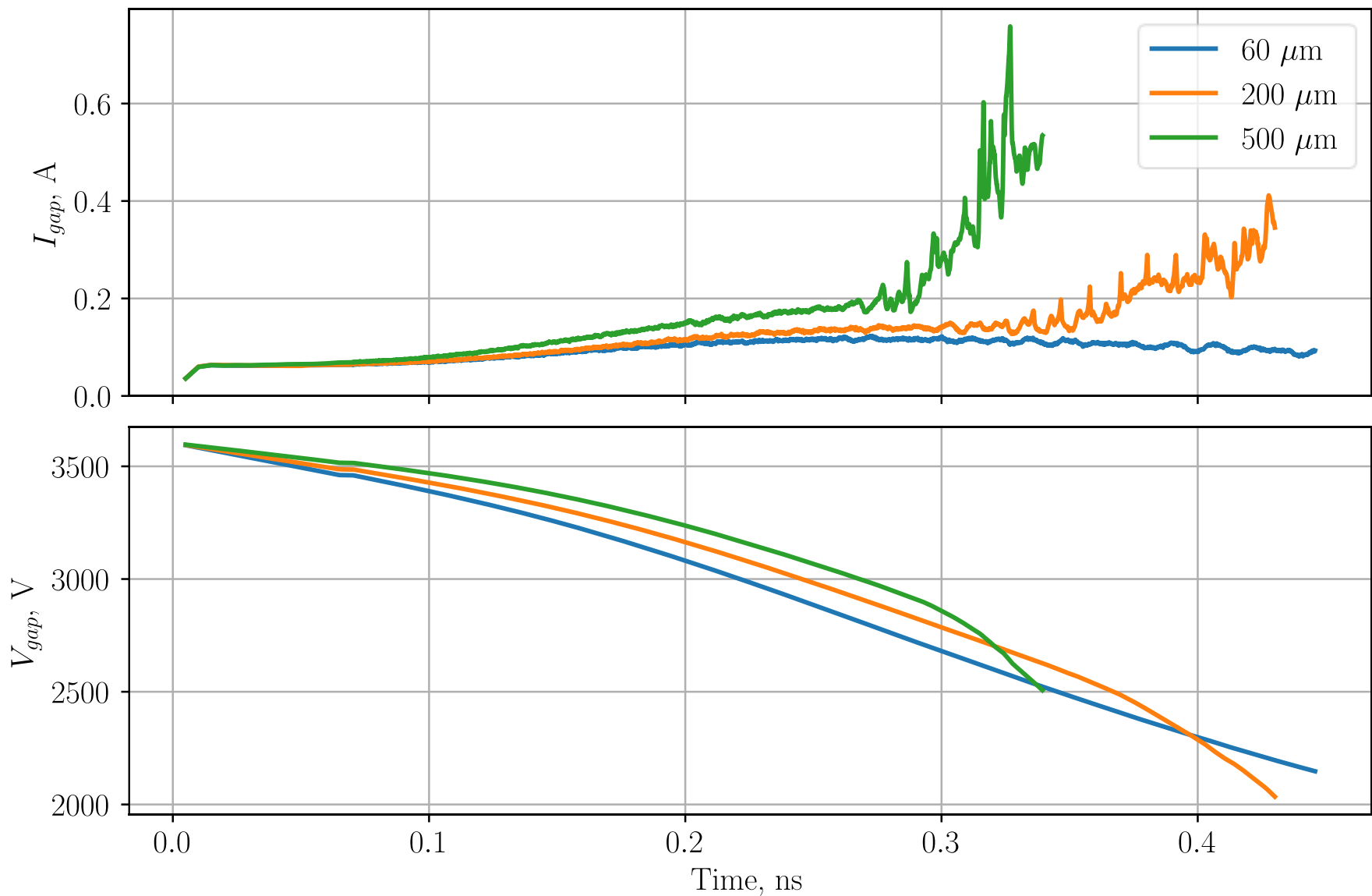

* Intentionally modified applied field !!

RC circuit case study -> $H = 2.5 \mu\text{m}$

MATTER

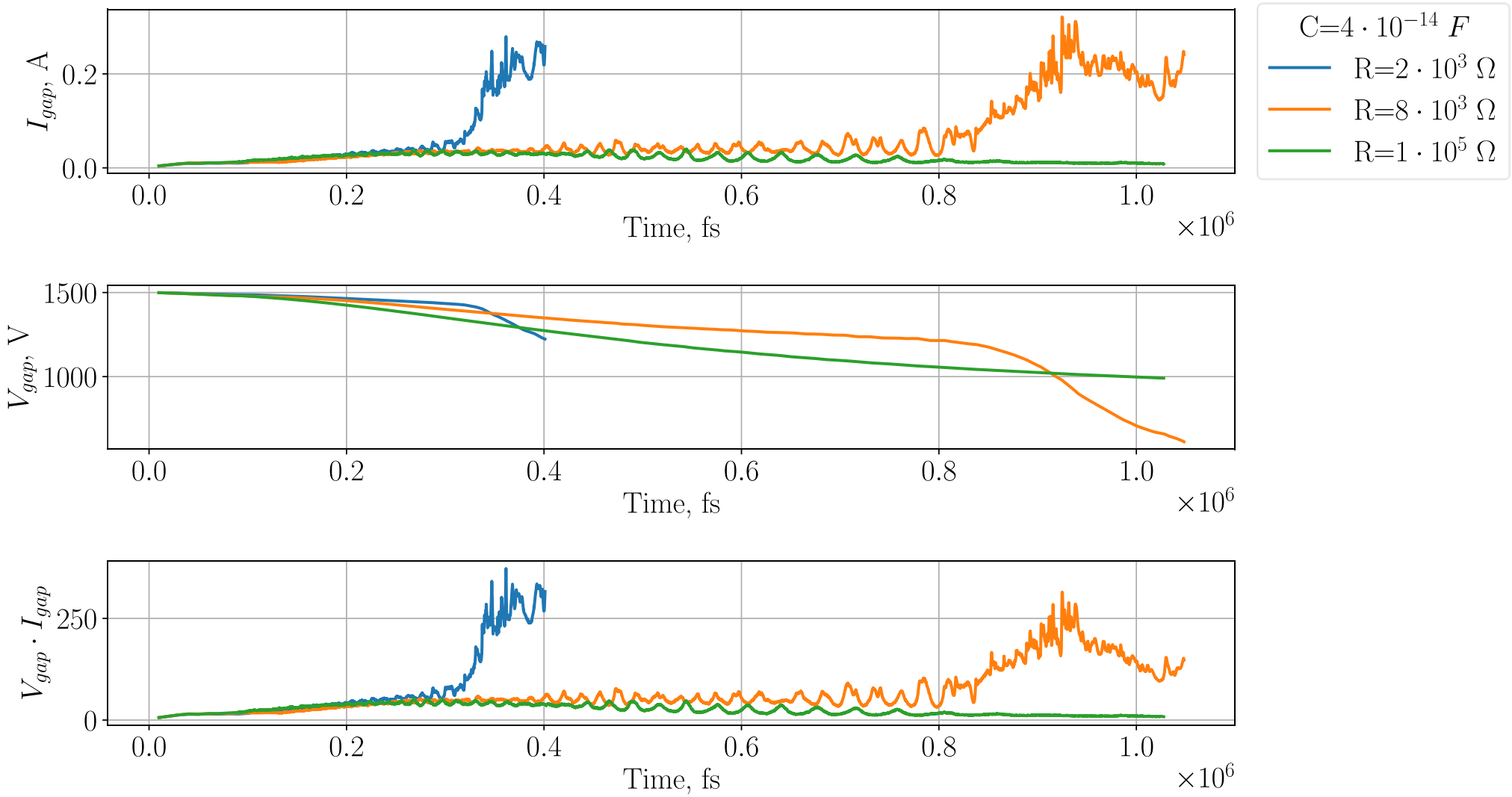

RC circuit case study -> $H = 1 \mu\text{m}$

MATTER

- Electrons
- Neutrals
- Ions

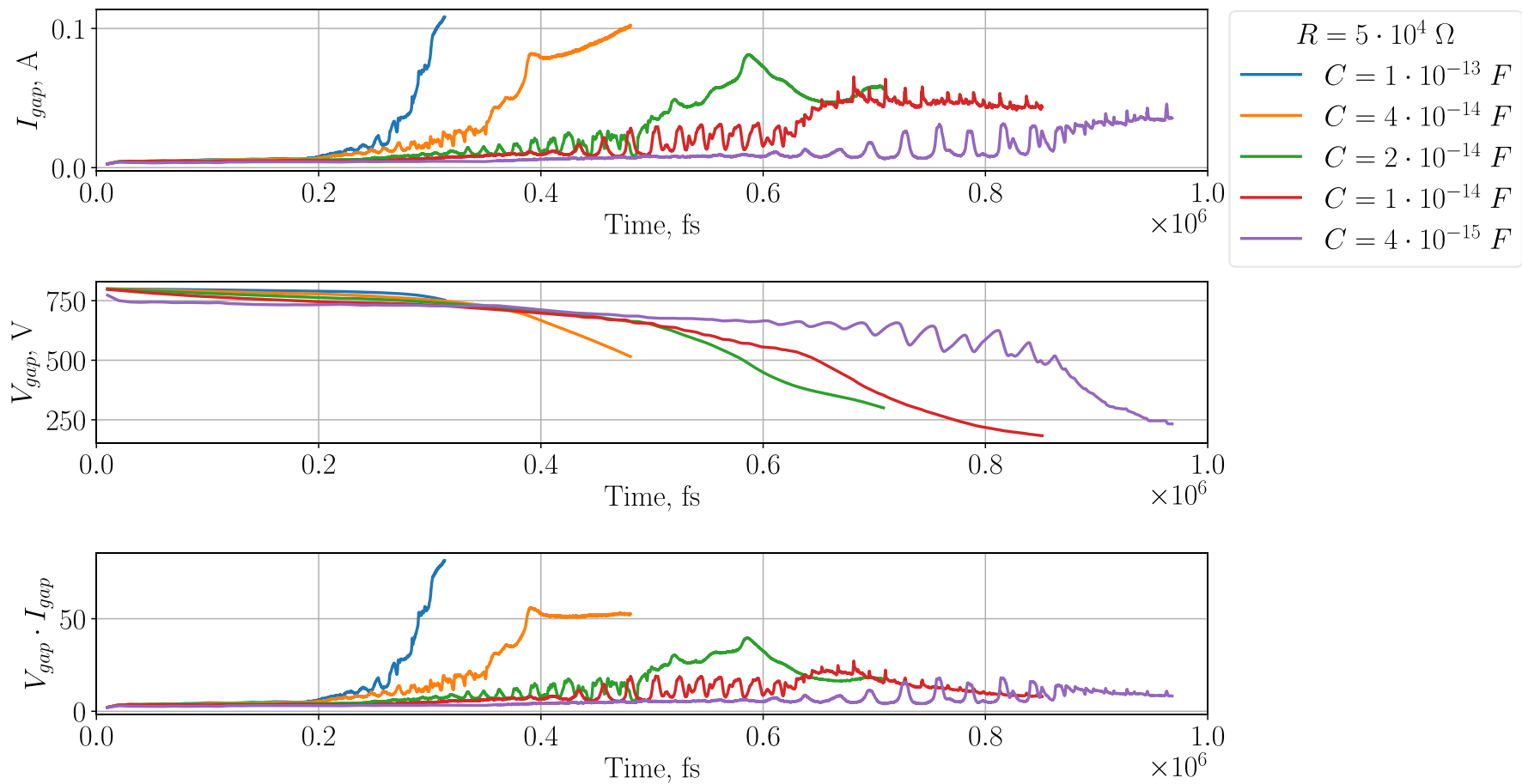

RC circuit case study -> $H = 0.6 \mu\text{m}$

MATTER

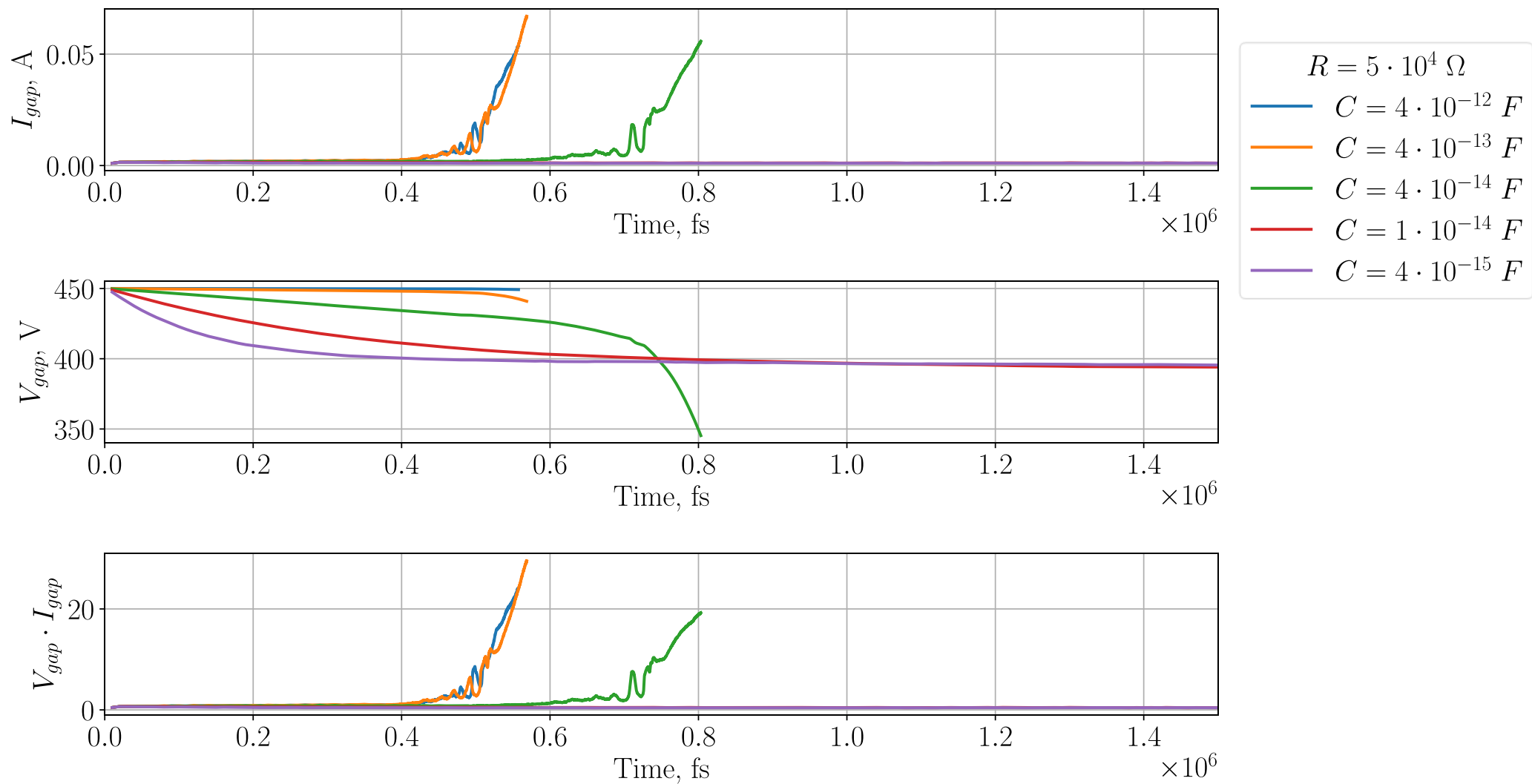

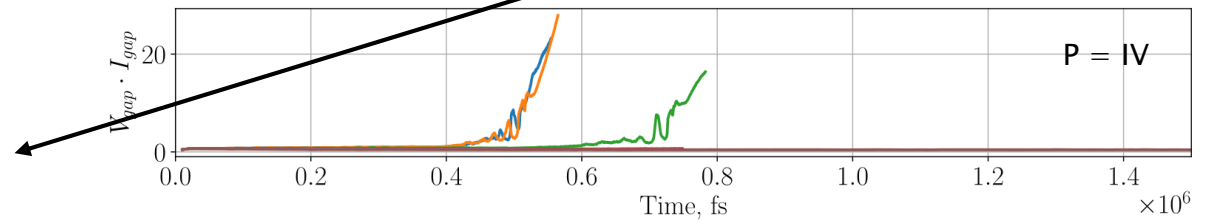
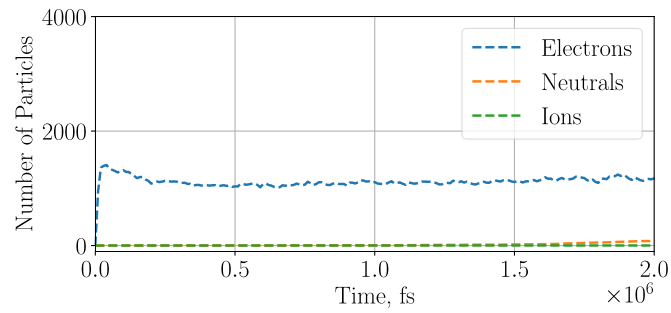
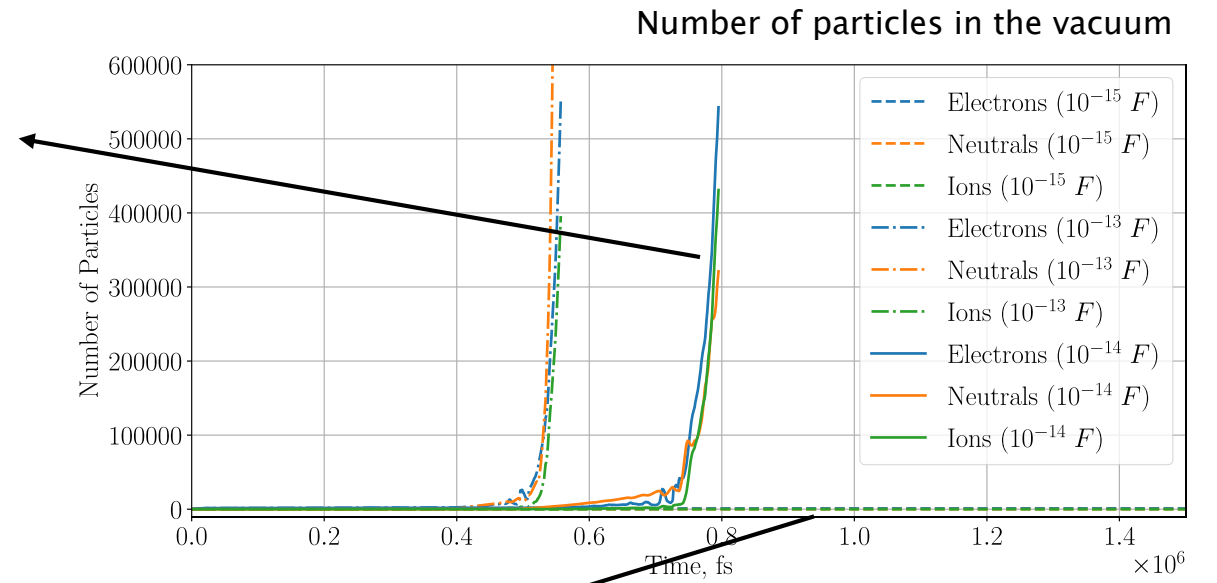
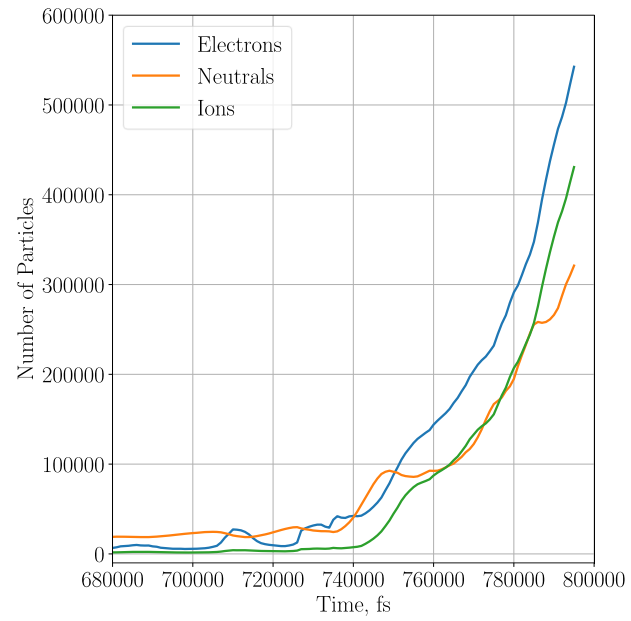



MATTER

Breakdown Monte-Carlo simulation

BDMC

- Surface state deteriorates at constant rate (s^{-1})
- Thermal runaway slightly improves the surface state
- Breakdown “cleans up” (resample)

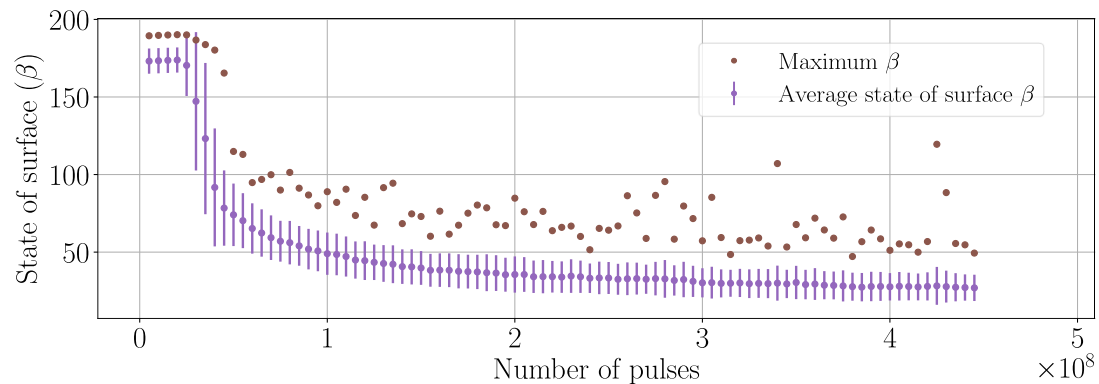
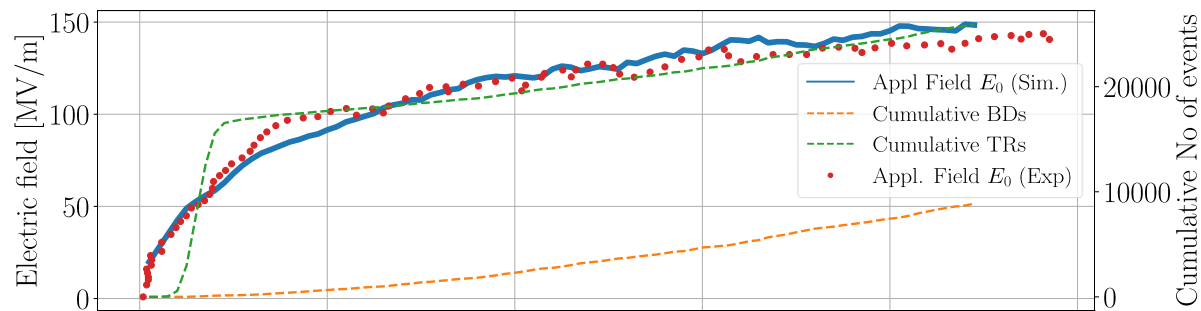
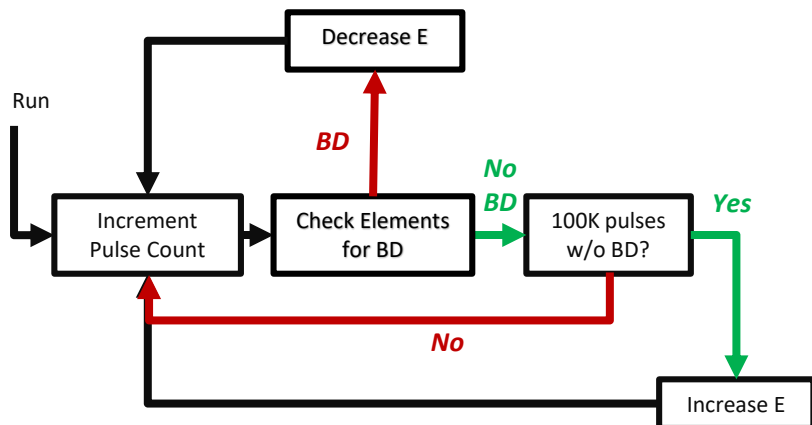

Model details: A. Kyritsakis, MeVArc 2025 talk: Monte Carlo simulations of vacuum breakdown occurrence dynamics and statistics

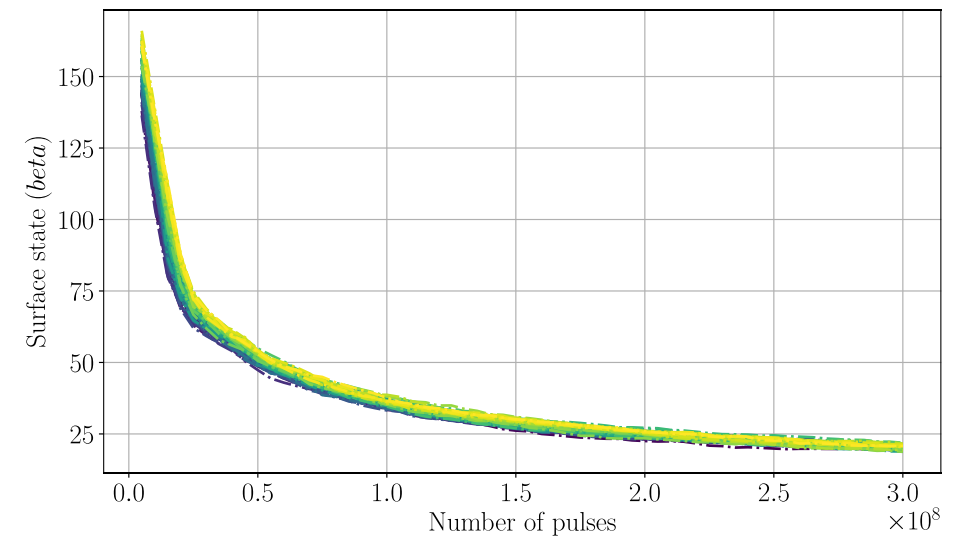
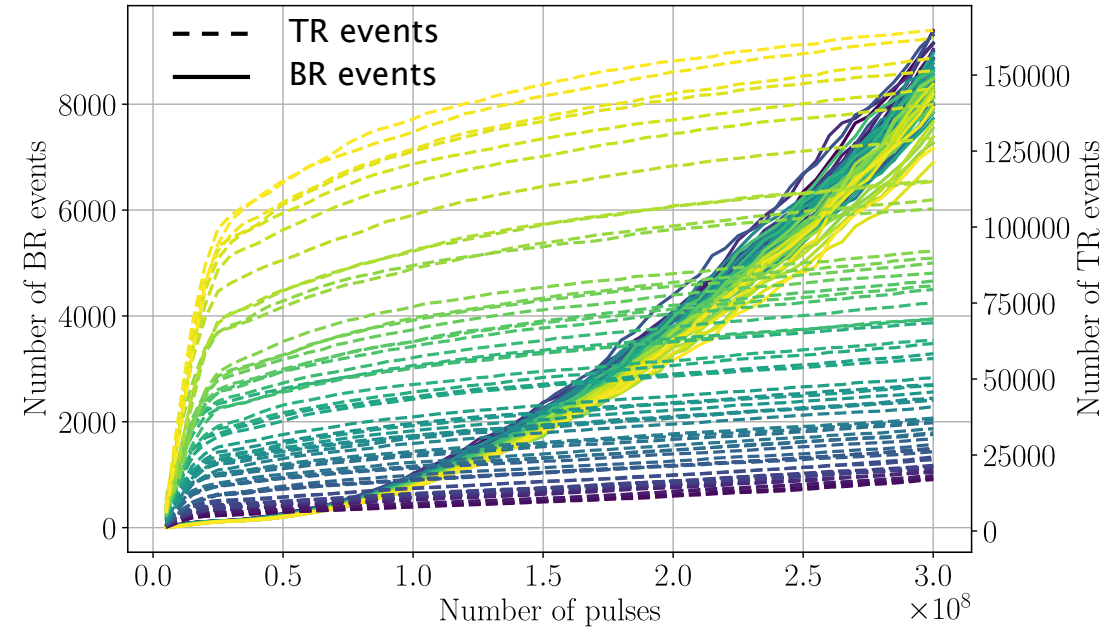
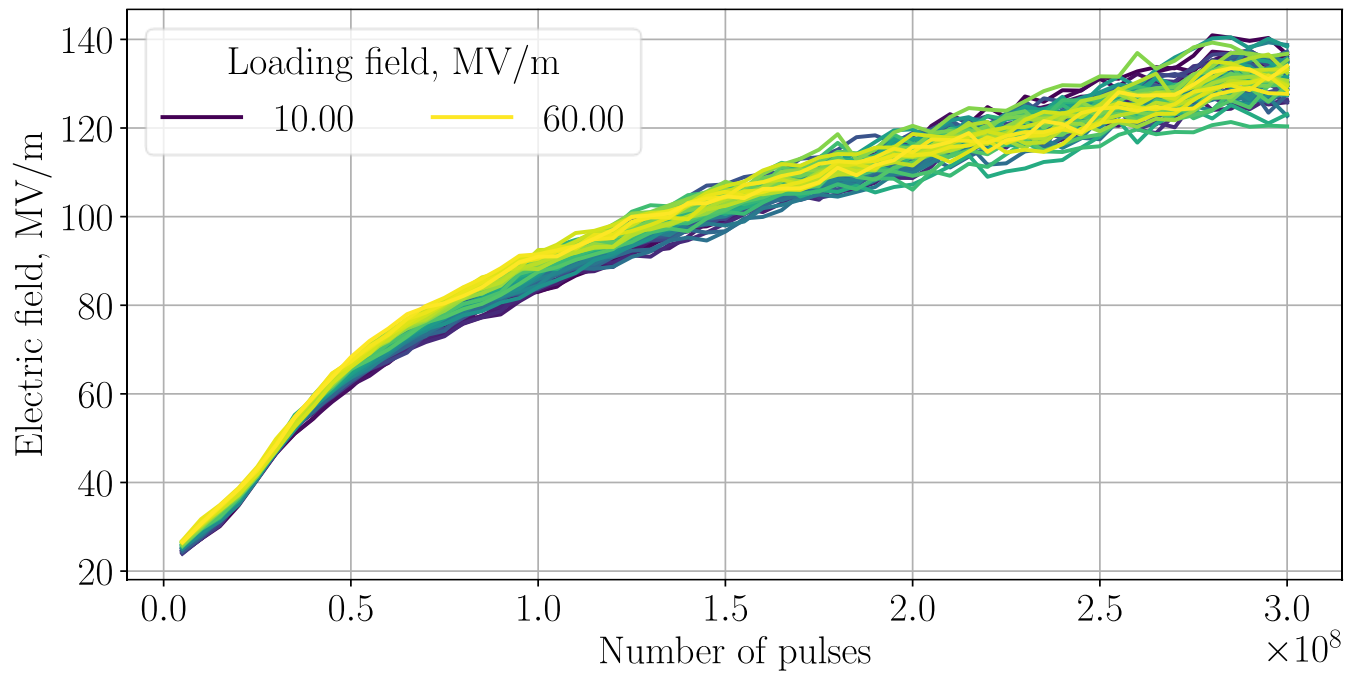

- „POC“: The impedance value plays a significant role in breakdown initiation process!
 - Evidence of strong dependence on system's power flow
 - Mitigation? (burning the asperities and current „choking“)
- Further work
 - *Existence of critical limit thresholds?*
 - Surface/tip morphology
 - **MD coupling & 3D [R. Koitermaa]**
 - *Continuum approach?*
 - Numerical investigation of the Pulse DC system (LES)
 - **FEMOCS** ← **Improved Impedance input**
 - BDMC

← **VALIDITY OF SHOWN RESULTS?**

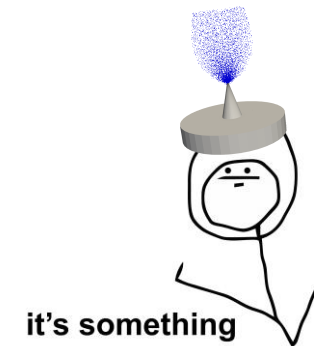

Calculated impedance at electrode center

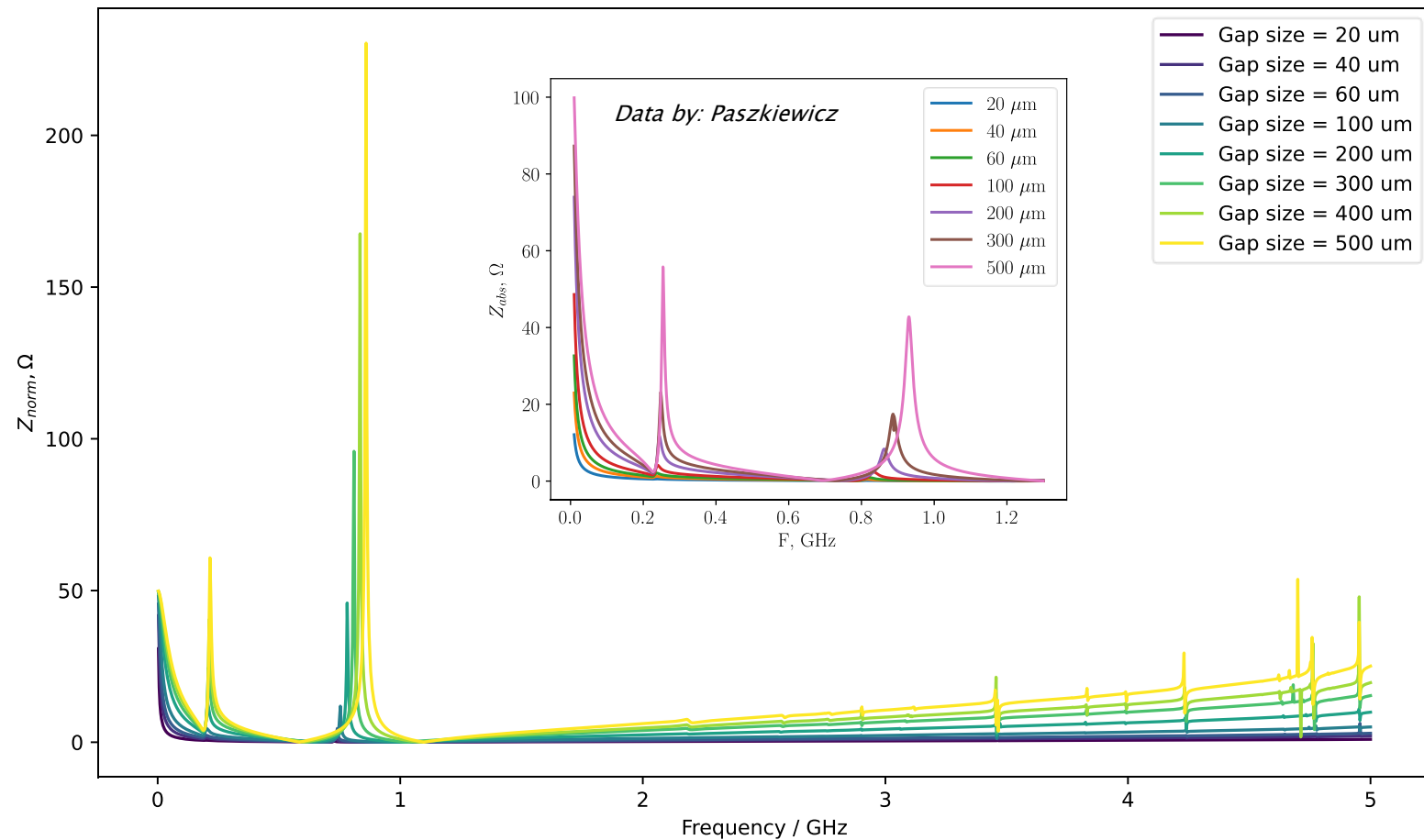

Data provided by: Lee Millar, CERN

Soft Cu electrode. Image: Saressalo

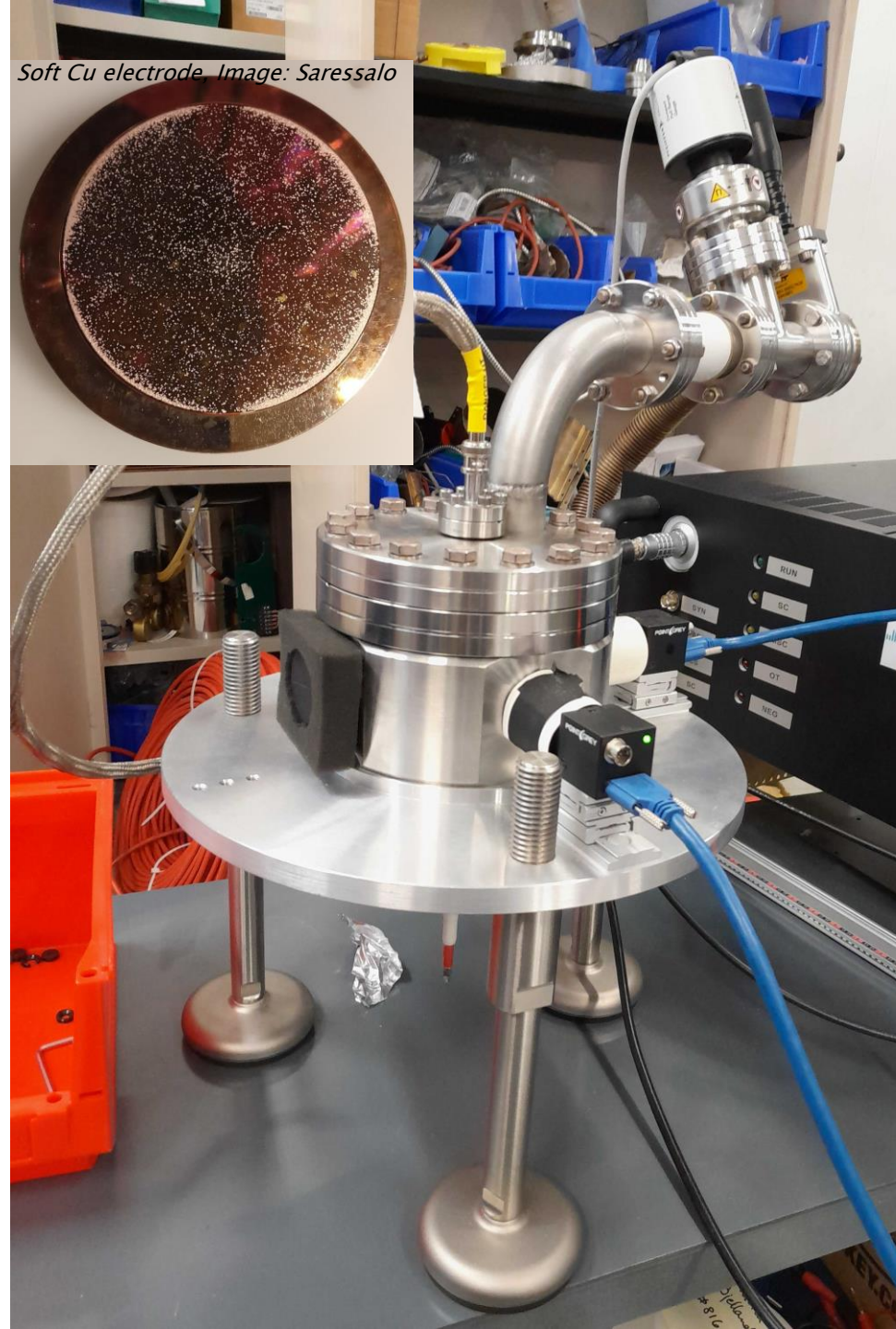

Thank you for your time!

This work is funded by:

Estonian Research Grant nr SJD66

ERA Chair "MATTER"

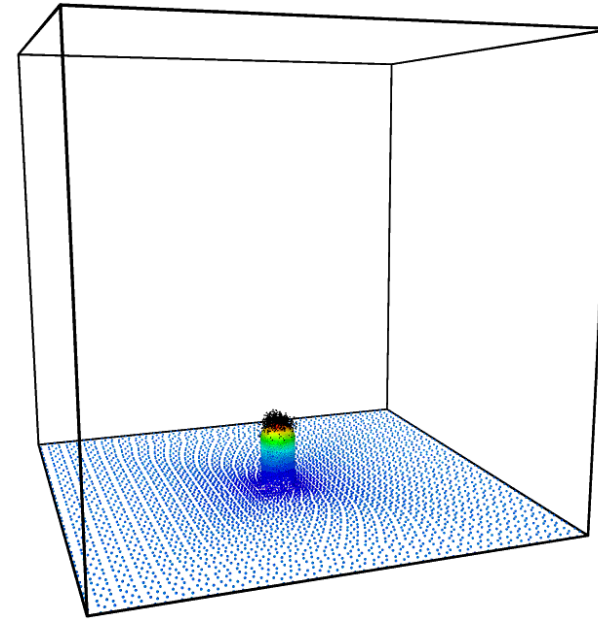
MATTER

Selection of FEMOCS Publications:

- Koitermaa, Roni, et al. "Simulating vacuum arc initiation by coupling emission, heating and plasma processes." *arXiv preprint arXiv:2402.08404* (2024).
- M. Veske, A. Kyritsakis, F. Djurabekova, K. N. Sjobak, A. Aabloo, and V. Zadin. Dynamic coupling between particle-in-cell and atomistic simulations. *Phys. Rev. E*, 101:053307, May 2020.
- M. Veske, A. Kyritsakis, K. Eimre, V. Zadin, A. Aabloo, and F. Djurabekova. Dynamic coupling of a finite element solver to large-scale atomistic simulations. *Journal of Computational physics*, 367:279 – 294, 2018.
- M. Veske, "Multiscale-multiphysics modelling of metal surfaces." *Report Series in Physics, PhD thesis* (2019).

Voltage drop

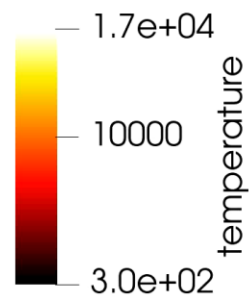
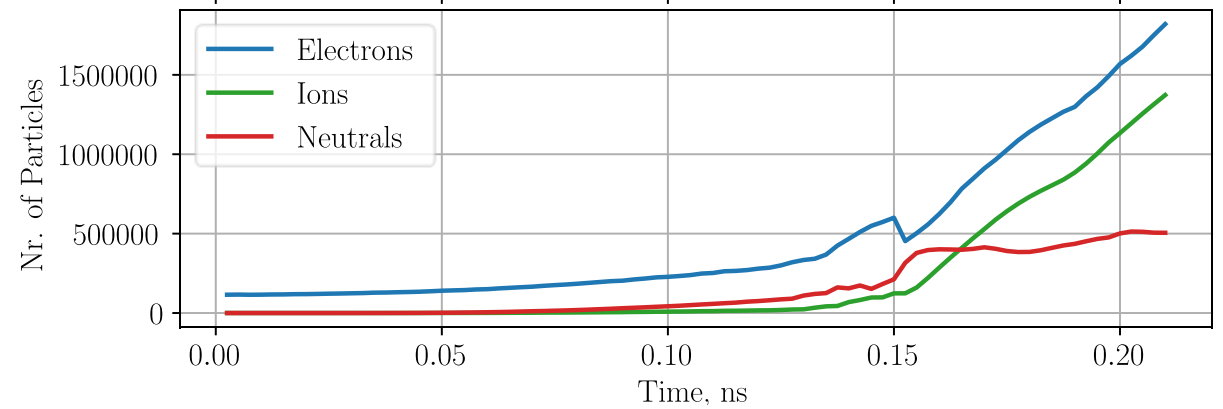
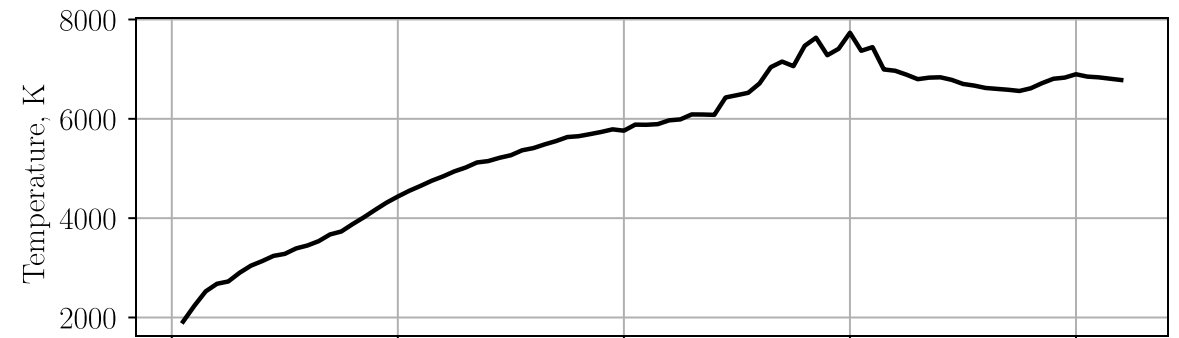
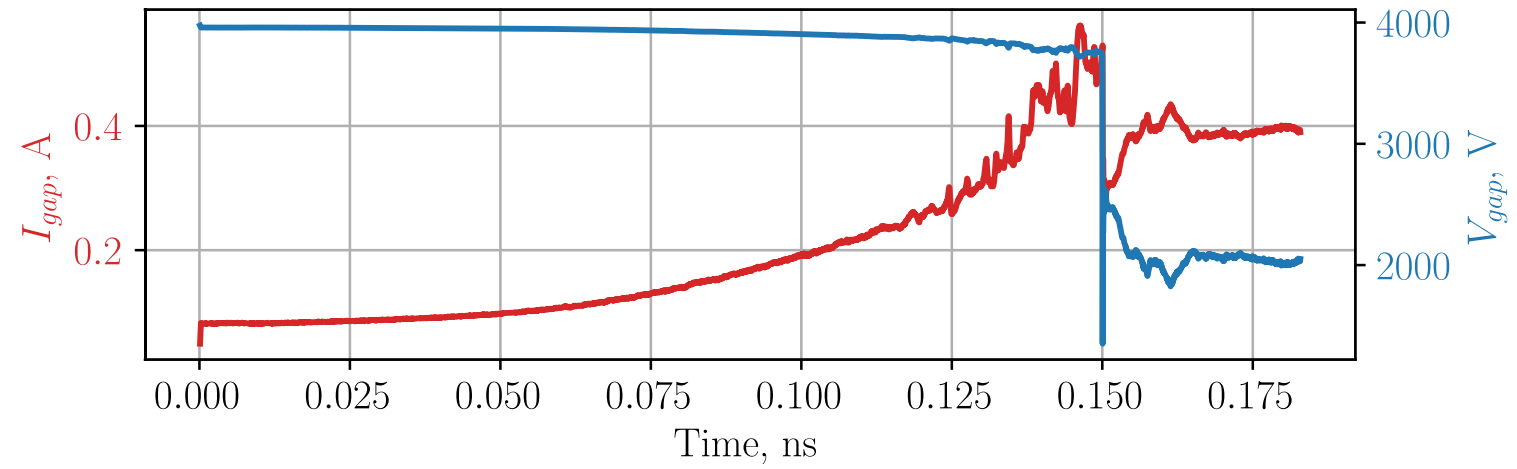

Qualitative nature of results

MATTER

- Z response (from J.Paszkievicz)
 - 1 MHz ... 1.3 GHz (>10 GHz)
 - RC fit for Z
- Tip geometry dependency (future work)
 - Static tip!
 - β & T
- Surface position indifference
 - center & edge

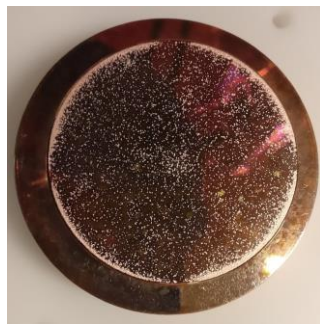

Soft Cu electrode, Image: Saessalo

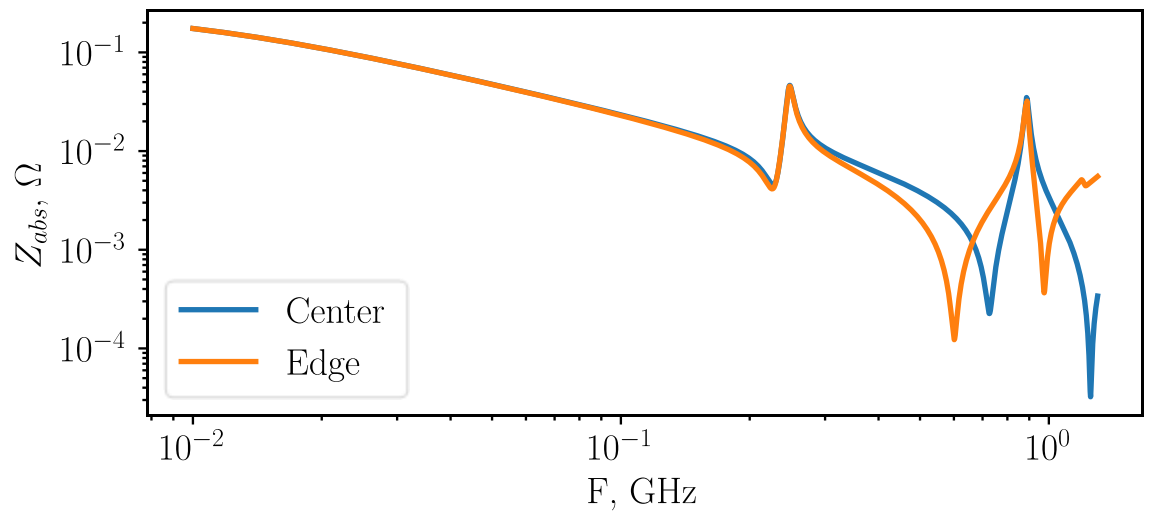
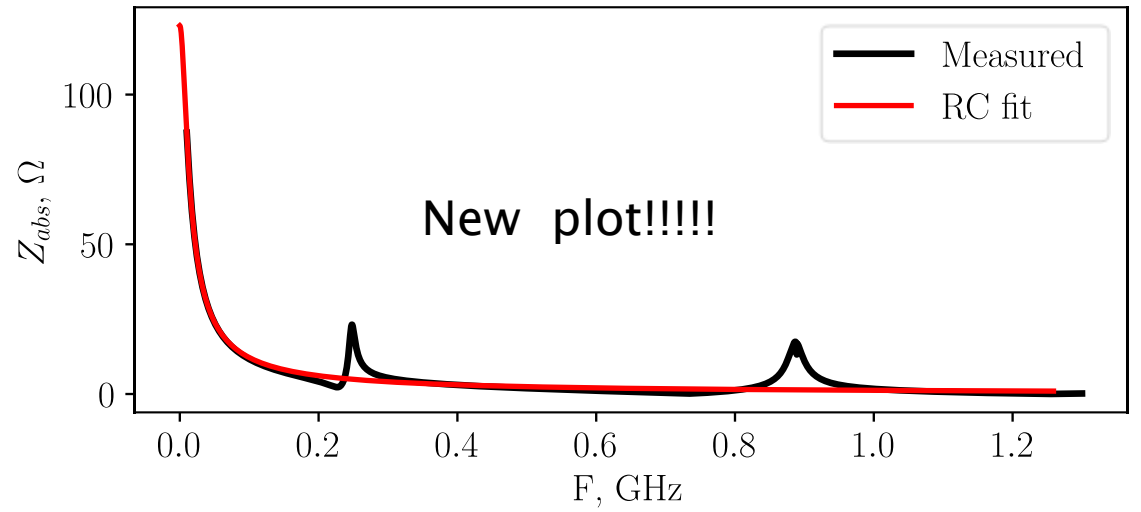

Preliminary LES simulation results

MATTER

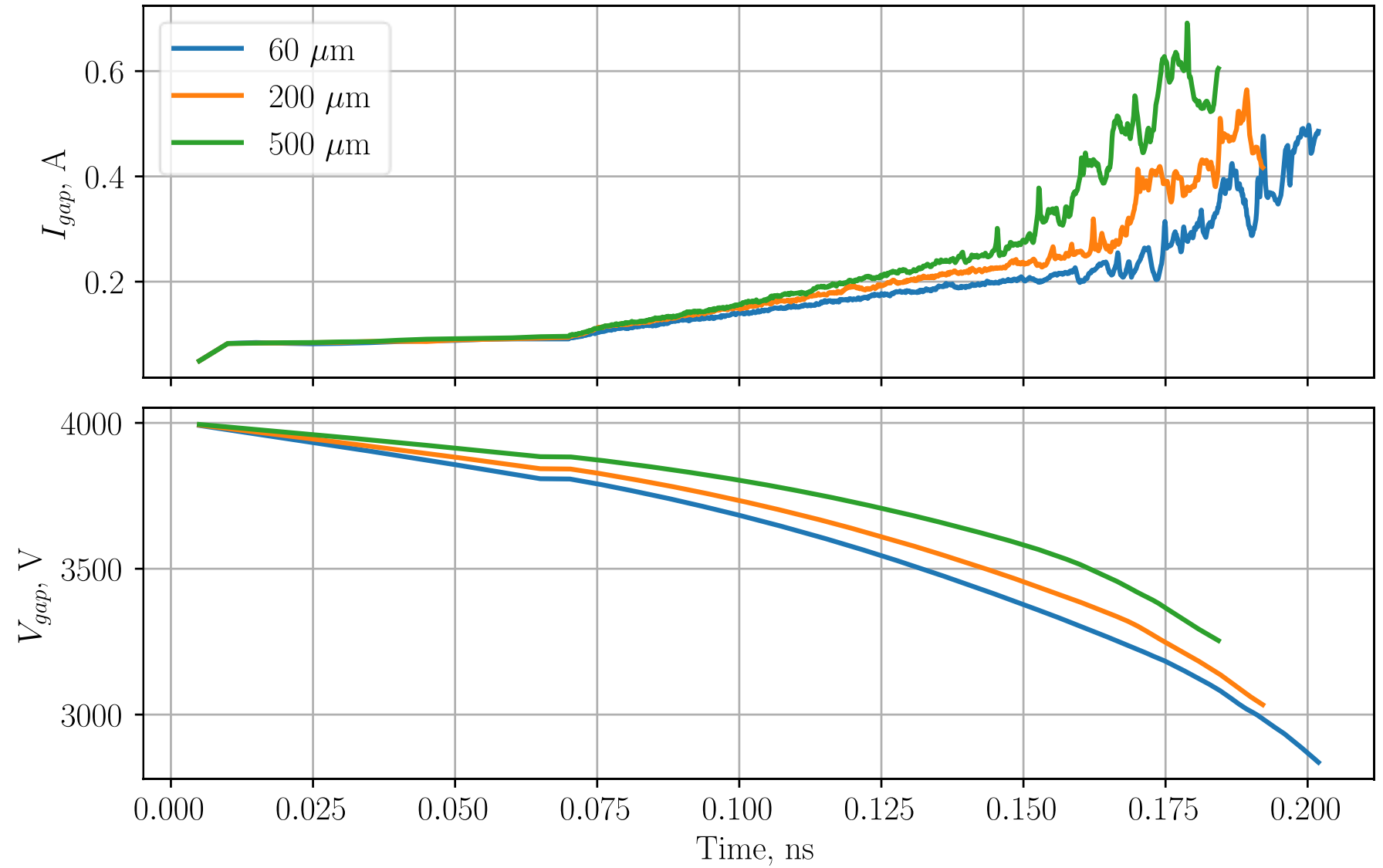



MATTER

gap current and voltage for tips with different H/R. For all cases, H=2500 nm, Voltage was 1500 V. Varying R

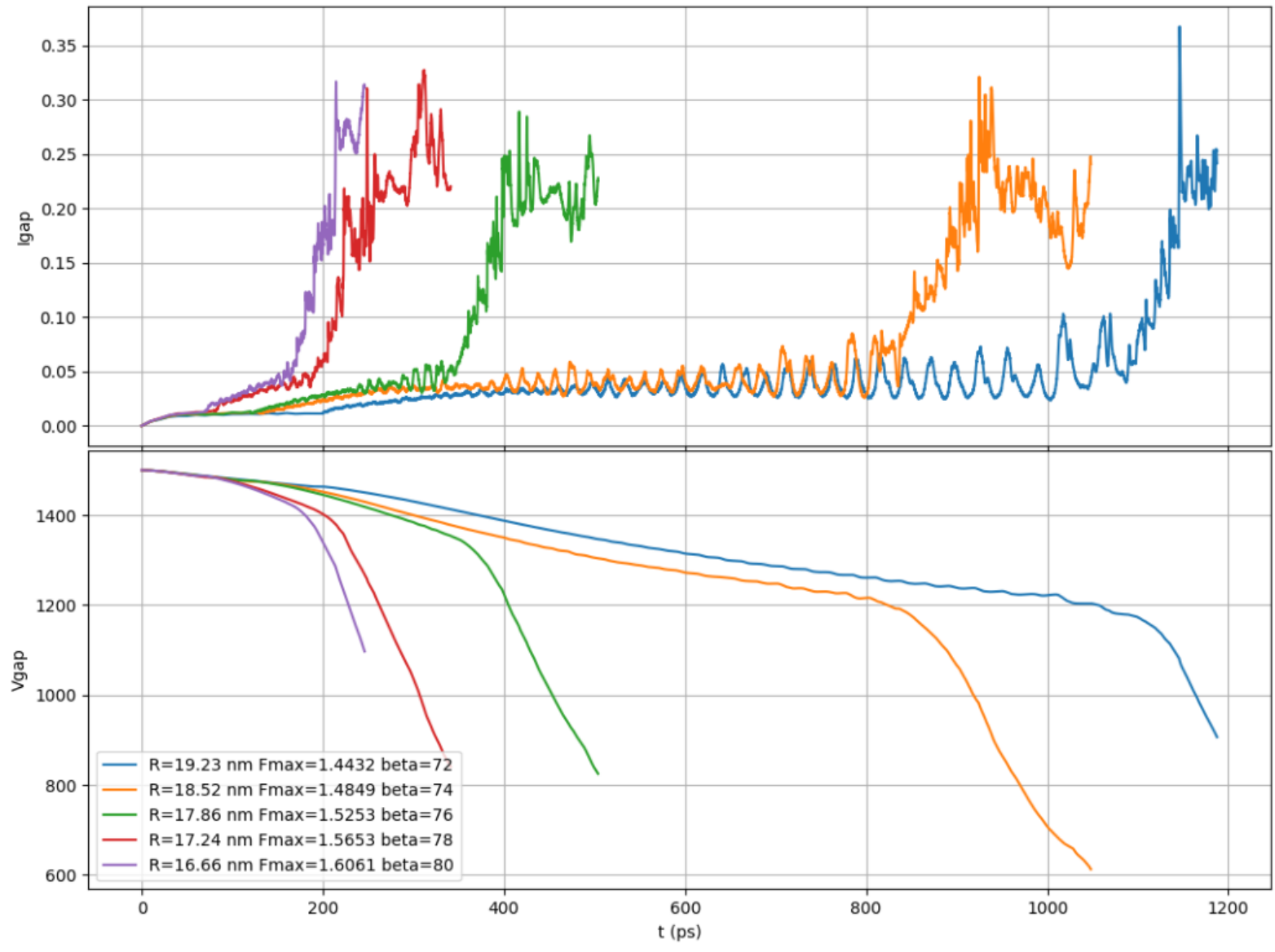

- Surface state deteriorates at constant rate (s^{-1})
- Thermal runaway slightly improves the surface state
- Breakdown “cleans up” (resample)

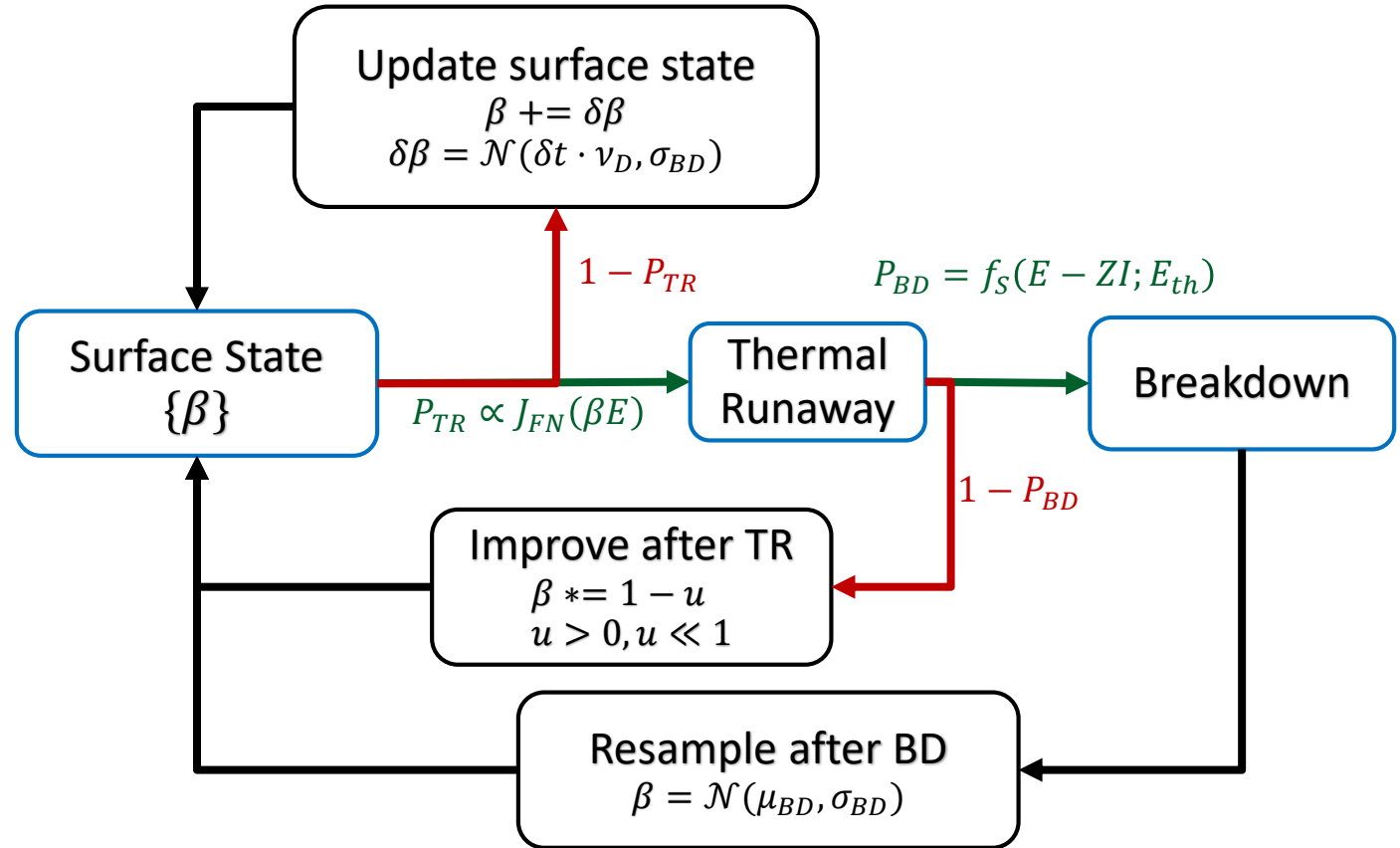

Model details: A. Kyritsakis, MeVArc talk: Monte Carlo simulations of vacuum breakdown occurrence dynamics and statistics

BDMC example study

MATTER

