

High gradient RF activities in SXFEL

Wencheng Fang, Cheng Wang

wangc@sari.ac.cn

Shanghai Synchrotron Radiation Facility

12th International Workshop on the Mechanisms of Vacuum Arcs (MeVArc2025)

June 1-5, 2025

Outline

- Background and Review of SXFEL
 - Photoinjector and the requirement of the RF gun
 - The main C-band linac
- The C-band RF gun
 - RF design and beam dynamics of the 3.6-cell gun
 - High power test of the C-band gun
 - The cryogenic gun
- The cryogenic C-band structure
 - RF design and low-power test
 - Status and plans
- Conclusion

Background and Review of SXFEL

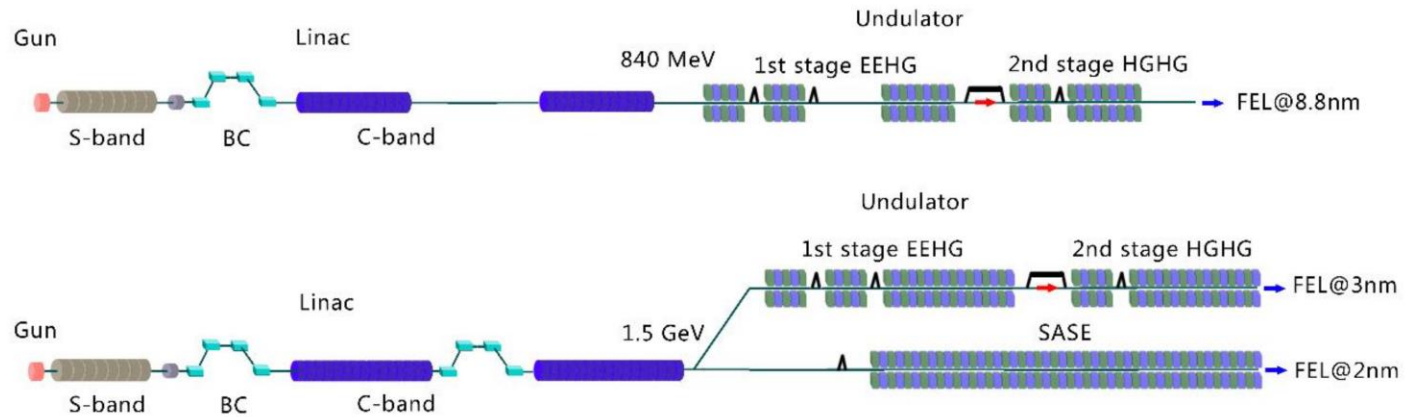

Parameter	Value
Electron energy	1.5GeV
Project energy spread	$\leq 0.1\%$
Normalized project emittance	1.5mm-mrad
Bunch charge	500pC
Peak current	$\geq 700A$
Central wavelength	$\sim 2nm$
Peak power	$\geq 100MW$

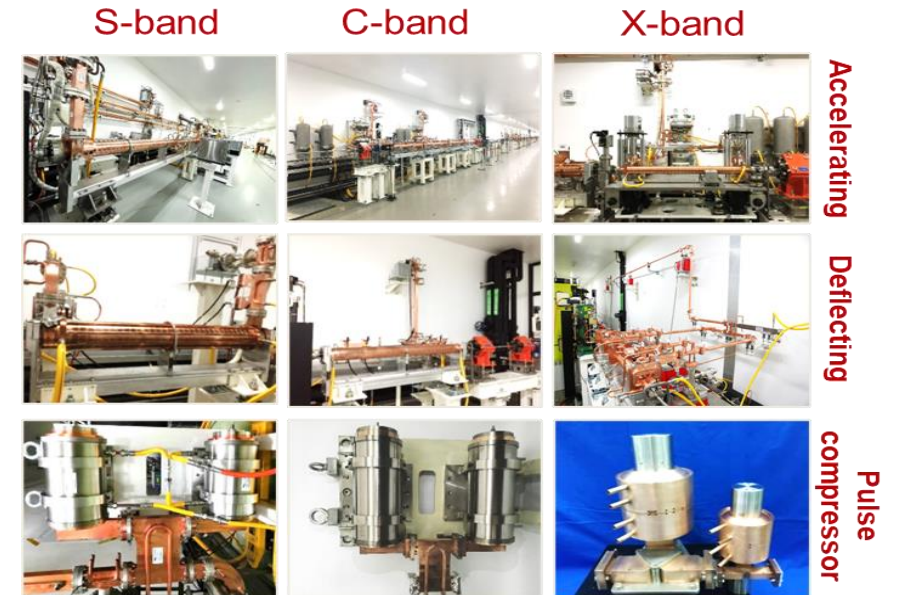

Photoinjector in SXFEL

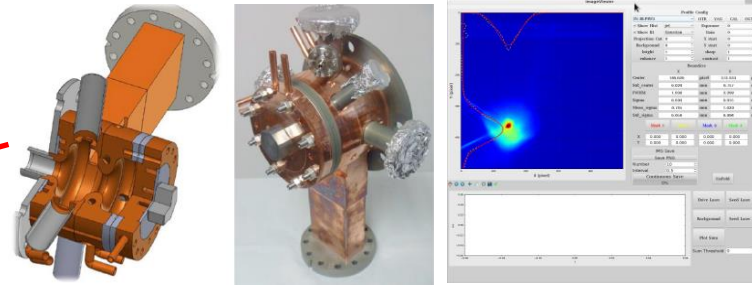
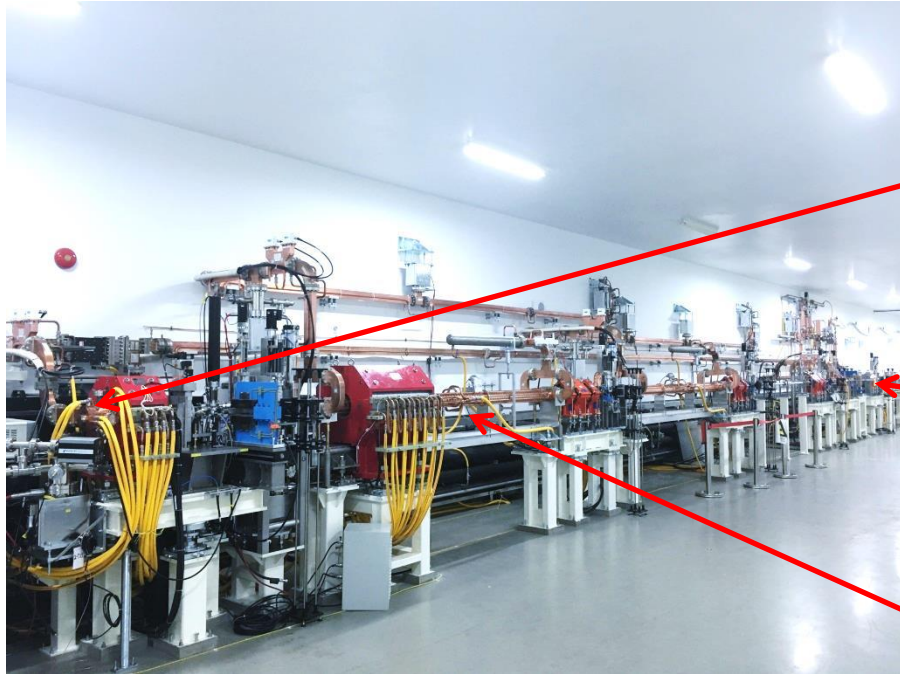

S-band gun from Tsinghua University
 90-100MV/m at the cathode
 500pC-1nC, 10ps initial bunch
 Irreplaceable cathode.



Two 3m S-band accs for linac-I
 17MV/m gradient designed
 Outer water cooling
 dipole and quadrupole field exit.

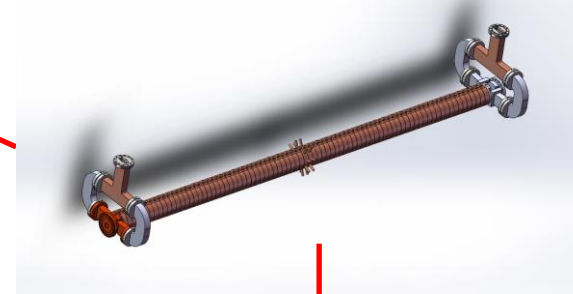

Two new 3m accs replaced in 2017
 Better performance on quadrupole field.
 But still a problem because of installation
 Inner water cooling.
 Gradient up to 23MV/m to reach 130MeV of injector.

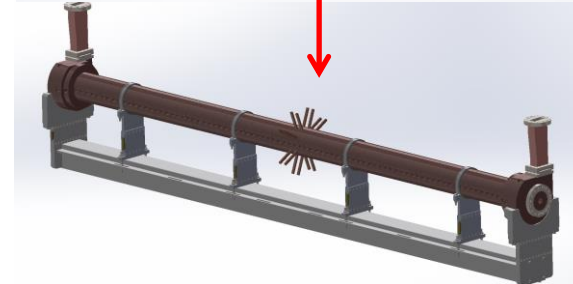

Two latest 3m accs replaced in 2023
 One-piece design, no installation on waveguide
 Great improvement

- Photoinjector:
 - Asymmetric transverse shaping suspected to be due to a quadrupole field
 - Micro-structure caused by the long laser profile shaped by the stacking technique
 - Heavy dark current

The main C-band linac



Breakdown rate statistics duration RF commissioning and operation

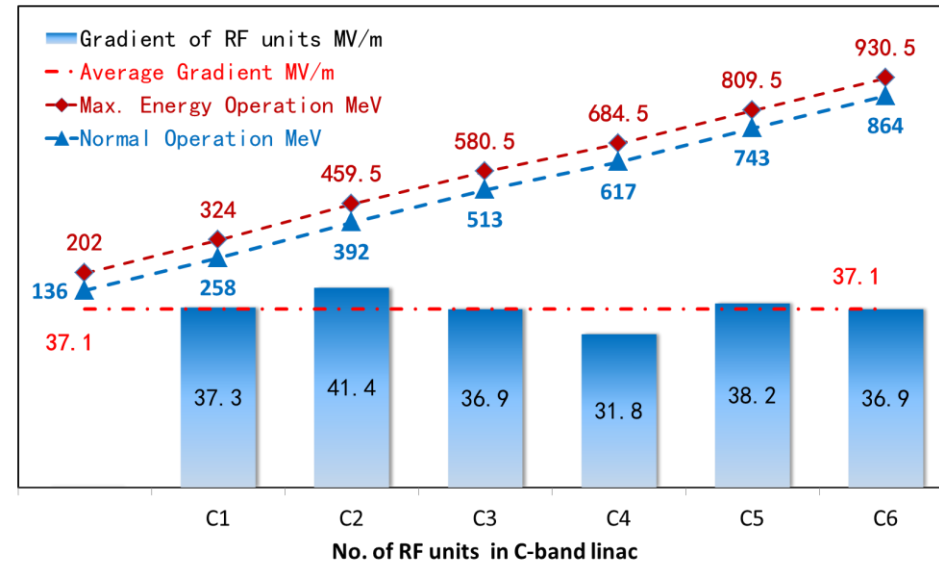
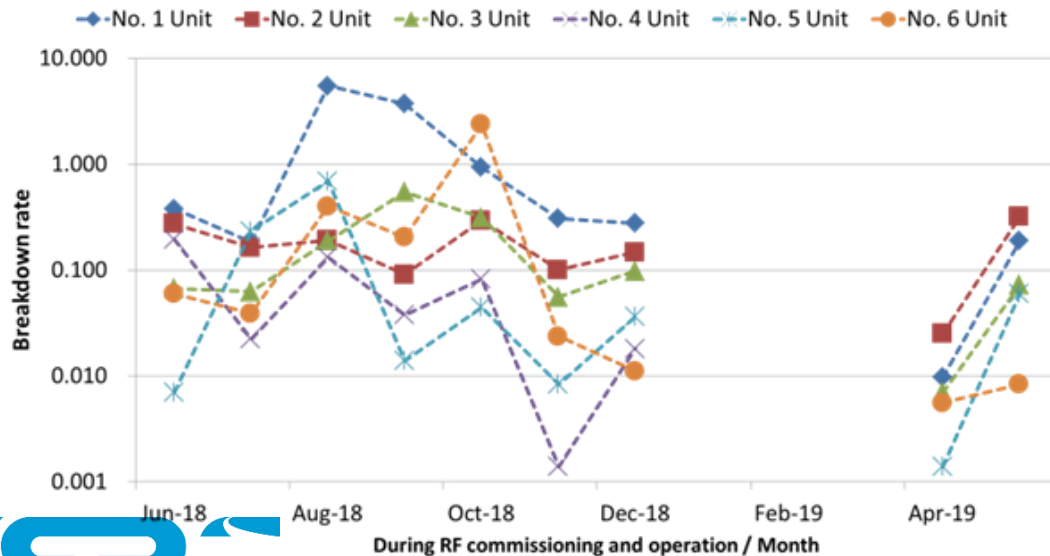

- 50MW klystron, multiply to 160MW
 - Feed in 2 C-band structure
- Experienced a terrible contamination
 - Average gradient is 37.1MV/m
 - Peak gradient is 41.7 MV/m

Motivation - Requirements in SXFEL

Photoinjector

- Micro-structure caused by the stacking technique
- Shorter initial beam (maintaining charge)
- Maintaining the current low emittance
- Removable photocathode (QE maintaining)

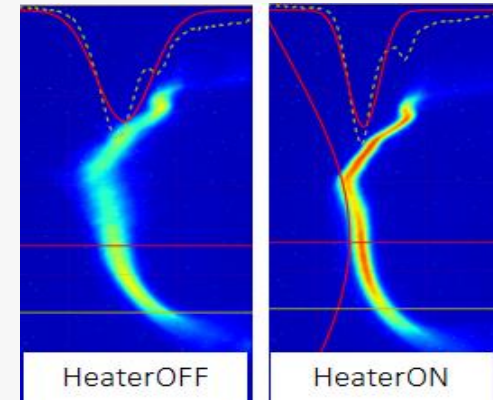

Main LINAC

- SXFEL-UF 1.5GeV, with plans to upgrade to 4 GeV
- Current remaining linear space can accommodate only up to 15 C-band units(+1.5GeV)
- Flat-top RF power output of pulse-compressor(120)
- Requires higher gradient RF structure, 65 MV/m is more reasonable for the space layout

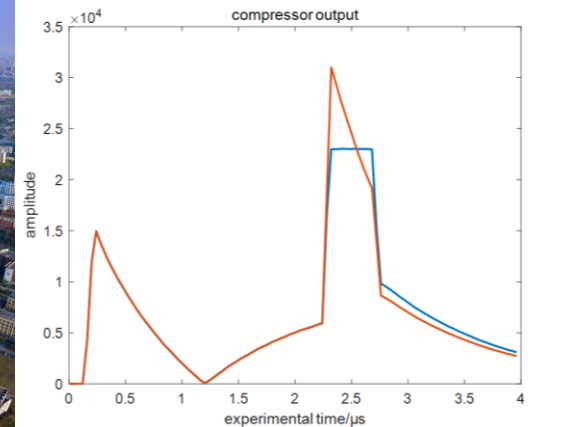

Outline

- Background and Review of SXFEL
 - Photoinjector and the requirement of the RF gun
 - The main C-band linac
- The C-band RF gun
 - RF design and beam dynamics of the 3.6-cell gun
 - High power test of the C-band gun
 - The cryogenic gun – design and preliminary high-power test
- The cryogenic C-band structure
 - RF design and low-power test
 - Status and plans
- Conclusion

The C-band photocathode gun - Proposal

Current, S-band

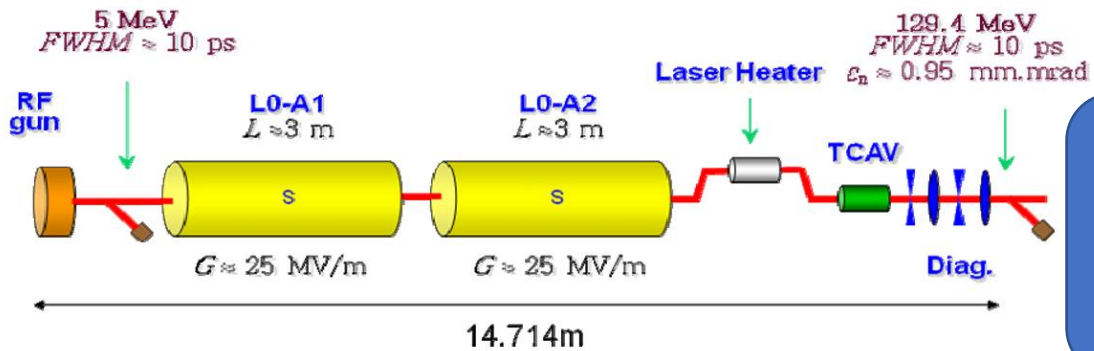

High brightness photocathode injector

$$\frac{\epsilon_{nCathode}}{\sigma_r} = \sqrt{\frac{\Delta E_C}{3mc^2}}$$

$$\epsilon_{sc} = \frac{\pi}{4} \frac{2mc^2}{eE_0} \frac{1}{\sin\phi_0} \frac{I_p}{I_A} \mu(A)$$

Higher gradient
New materials
Surface processing
DC vs rf, higher frequency
Local enhancement
.....

Brightness preservation:
Emittance compensation
Beam shaping
.....

Mean Transverse Energy
New material
Cryogenic cathode
.....

C-band scheme

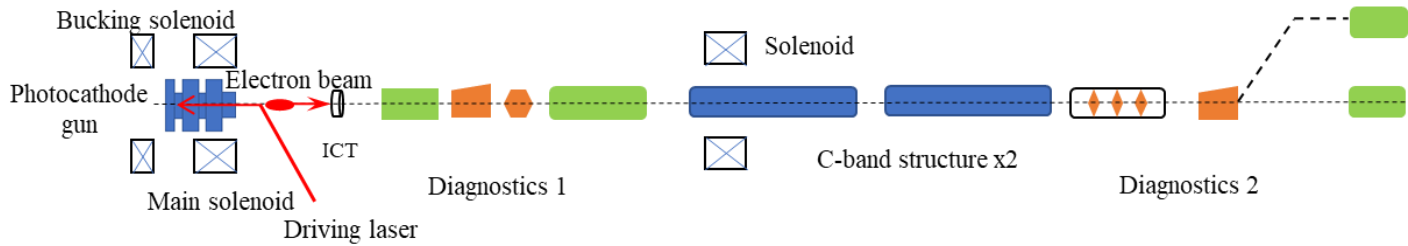

Parameters	Cryogenic gun	3.6-cell gun	S-band gun
Bunch charge (pC)	500		
Laser Pulse FWHM (ps)		5	10
RMS laser size (mm)		0.35	0.4
Emittance on the cathode (mm-mrad)		0.28	0.31
Beam energy (MeV)		107	120
Length (m)		<8	<15
Transverse emittance (mm-mrad)	0.32	0.44	0.71
RMS bunch length (mm)	0.465	0.47	0.6
Mean slice emittance (mm-mrad)	0.22	0.37	0.52

Upgrade scheme for SXFEL
Better beam performance
Facilitates bunch compression
Shorter layout for beam imaging

The C-band photocathode gun – Design and optimization

☐ Referred to the high-field BD models

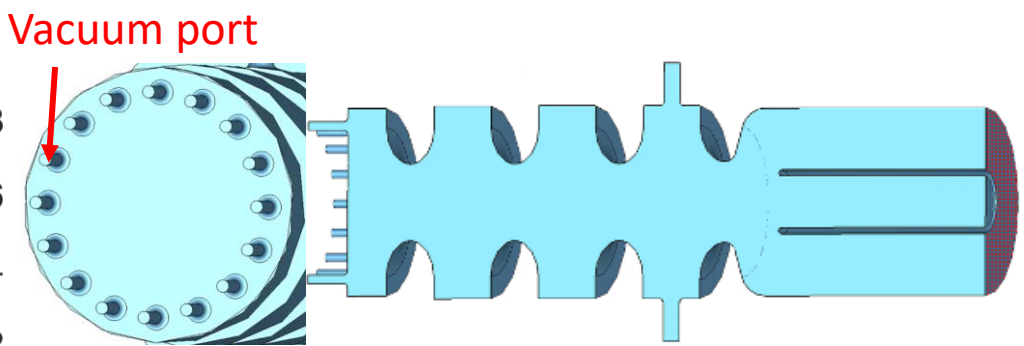
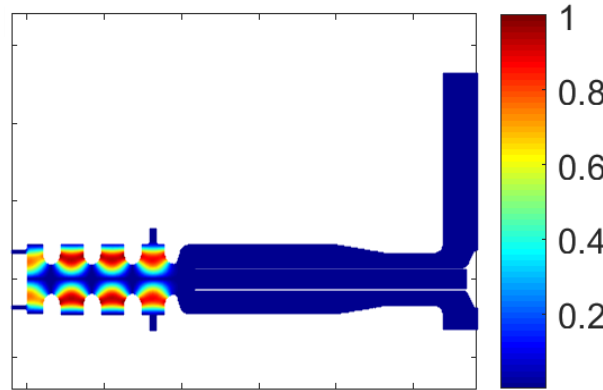
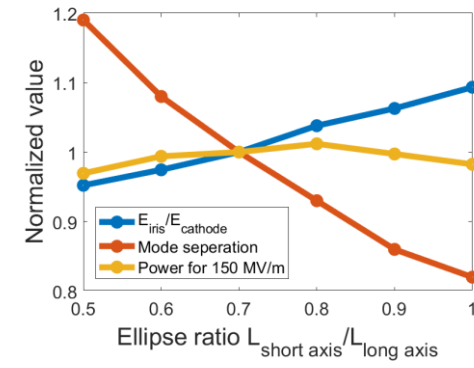
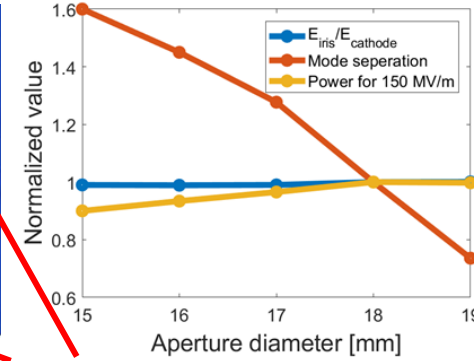
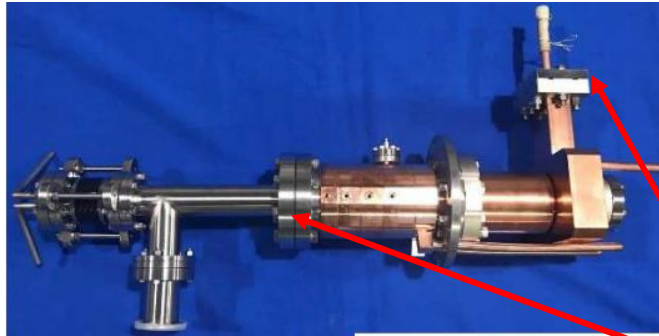
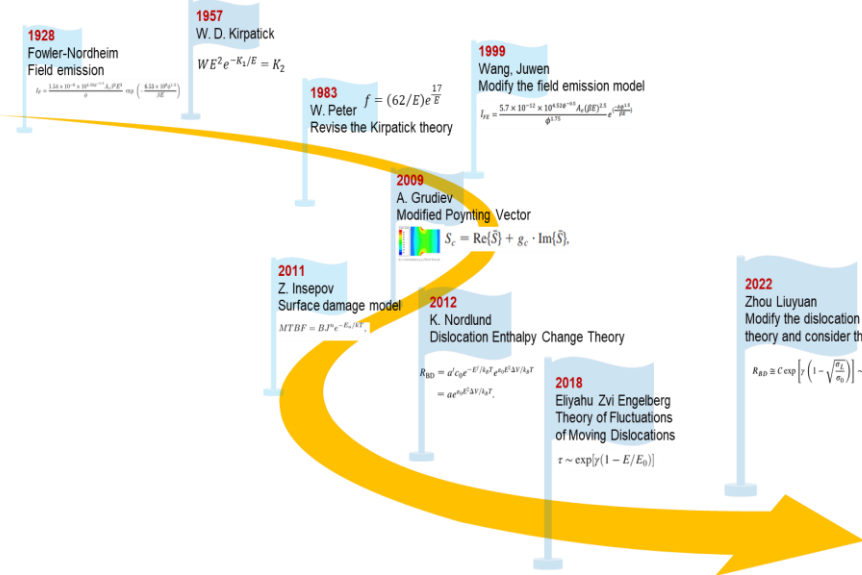

E field on the surface is 0.94 of that on the cathode
 150MV/m, $\max(S_c) = 2.7 \text{ W}/\mu\text{m}^2$
 More careful monopole suppression
 Additional vacuum port on cathode plate
 Removable cathode (20nm)

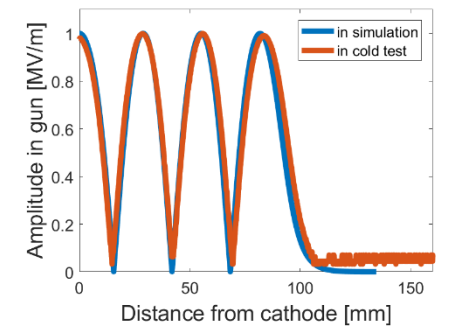
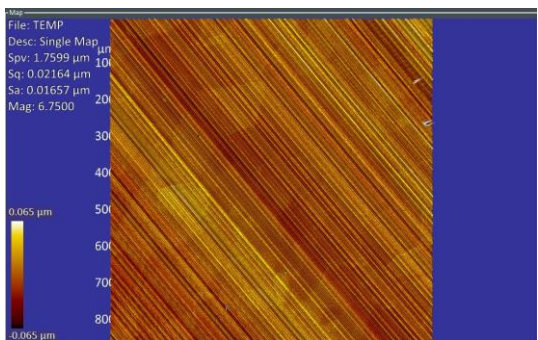

The C-band photocathode gun – High power test

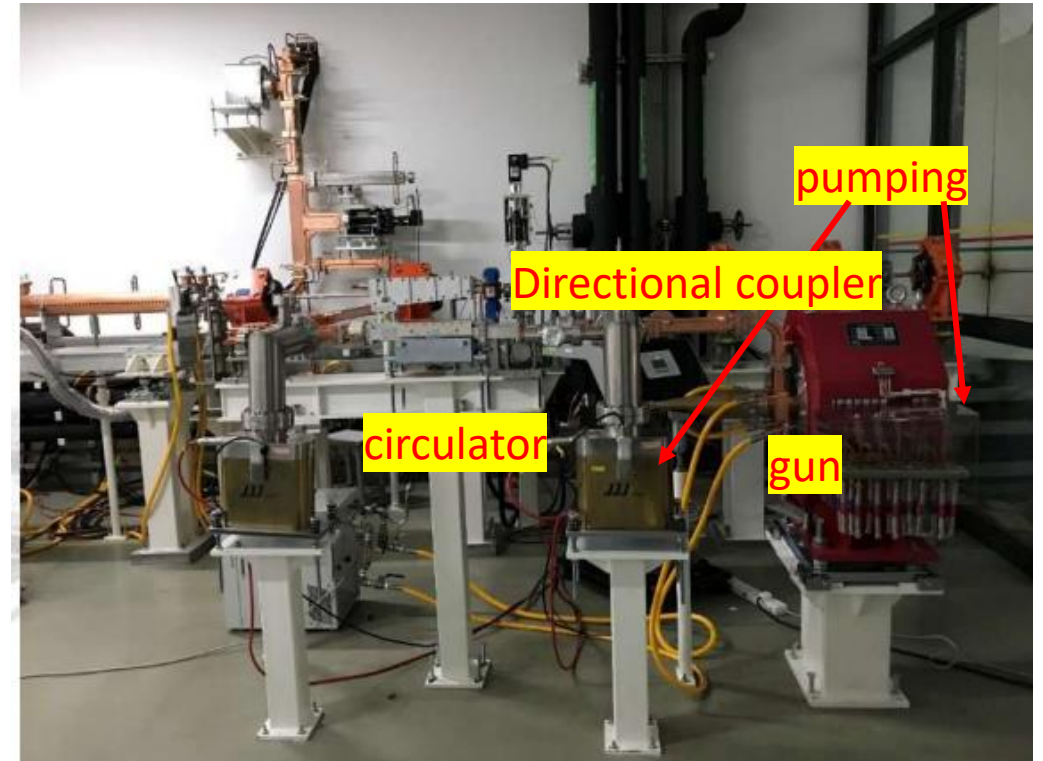
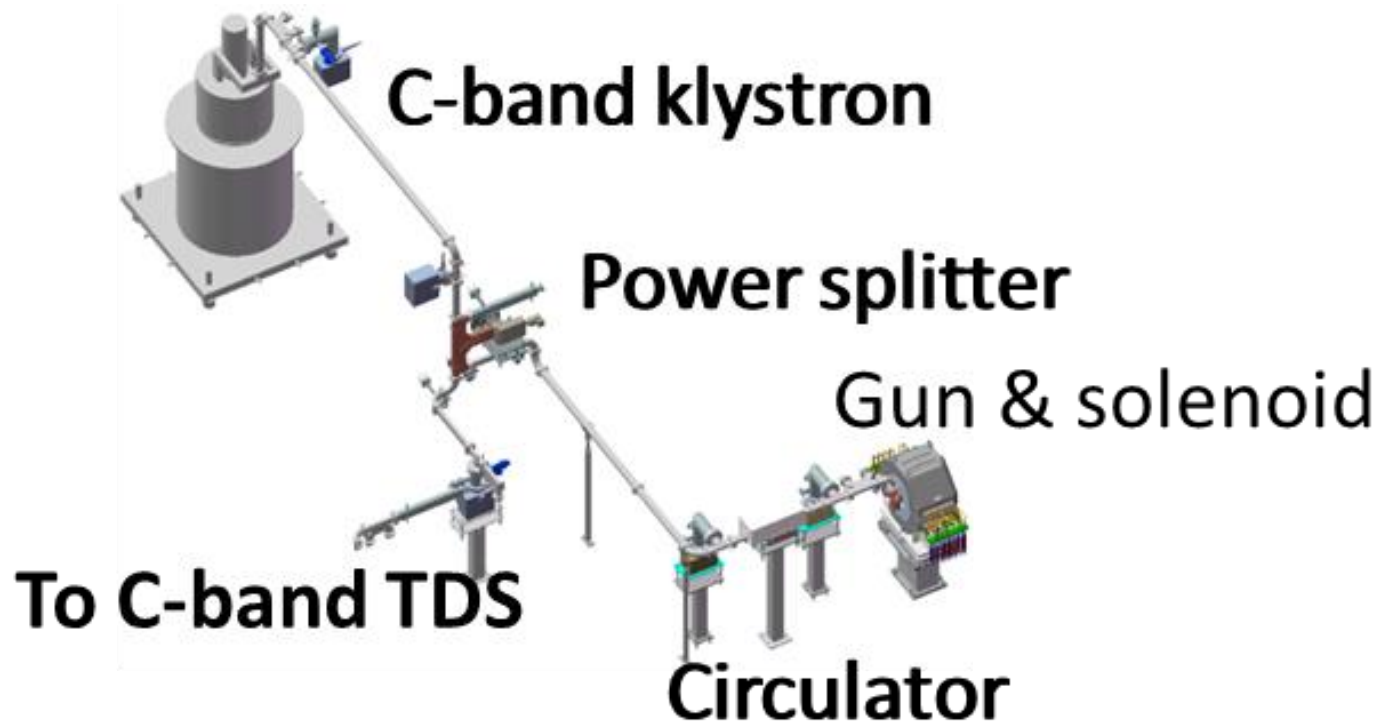

Inside the SXFEL tunnel

The C-band photocathode gun – High power test

- Repetition rate is 10Hz
- Pulse length from 0.5 μ s to 2.5 μ s
- 14MW \rightarrow 150MW/m
- Dark current can reach 2mA at 150MV/m
- Data system anomalies, BD data not available
- Lack of laser, SXFEL commissioning limit

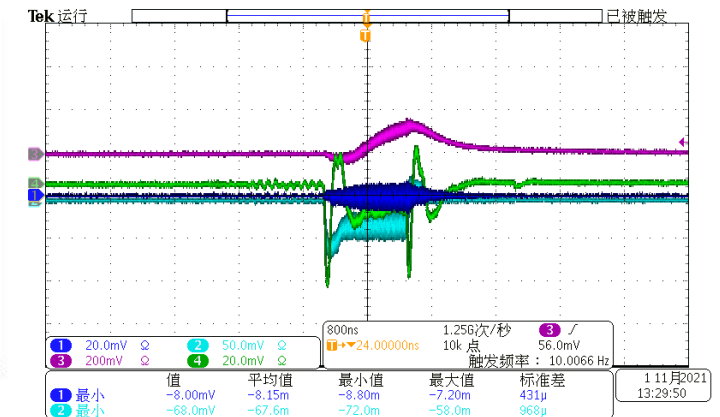
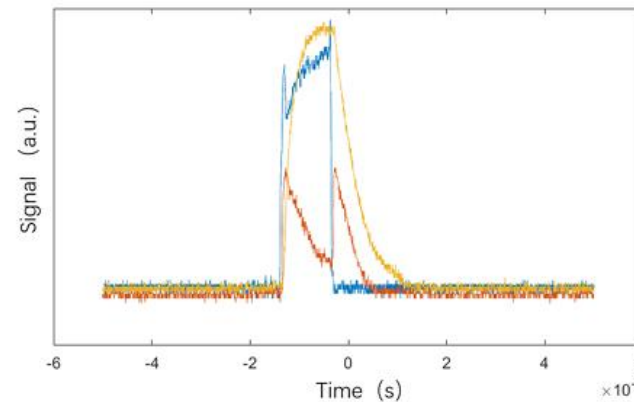
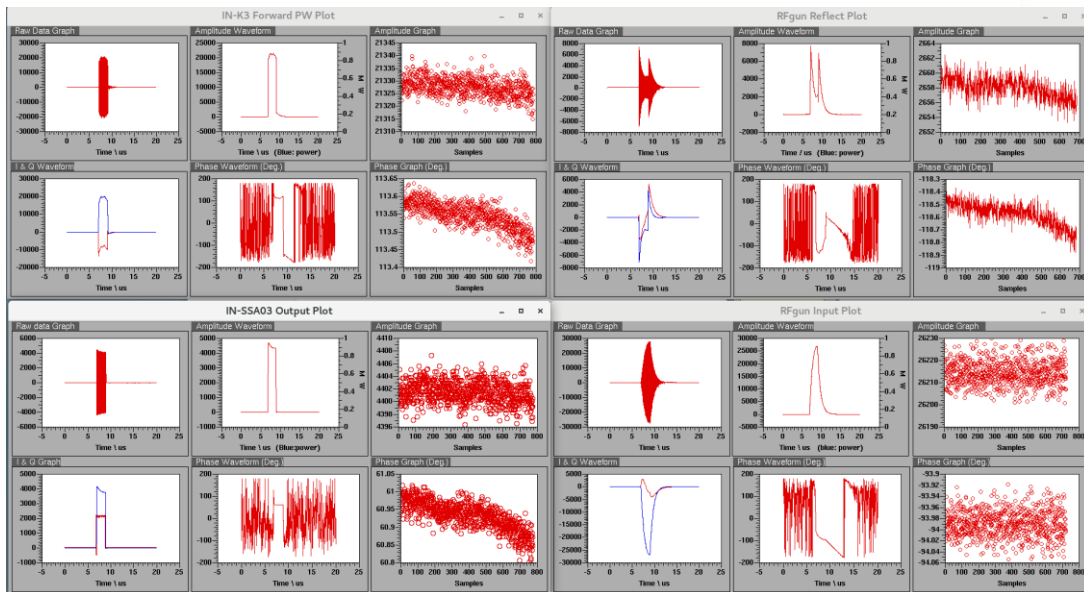
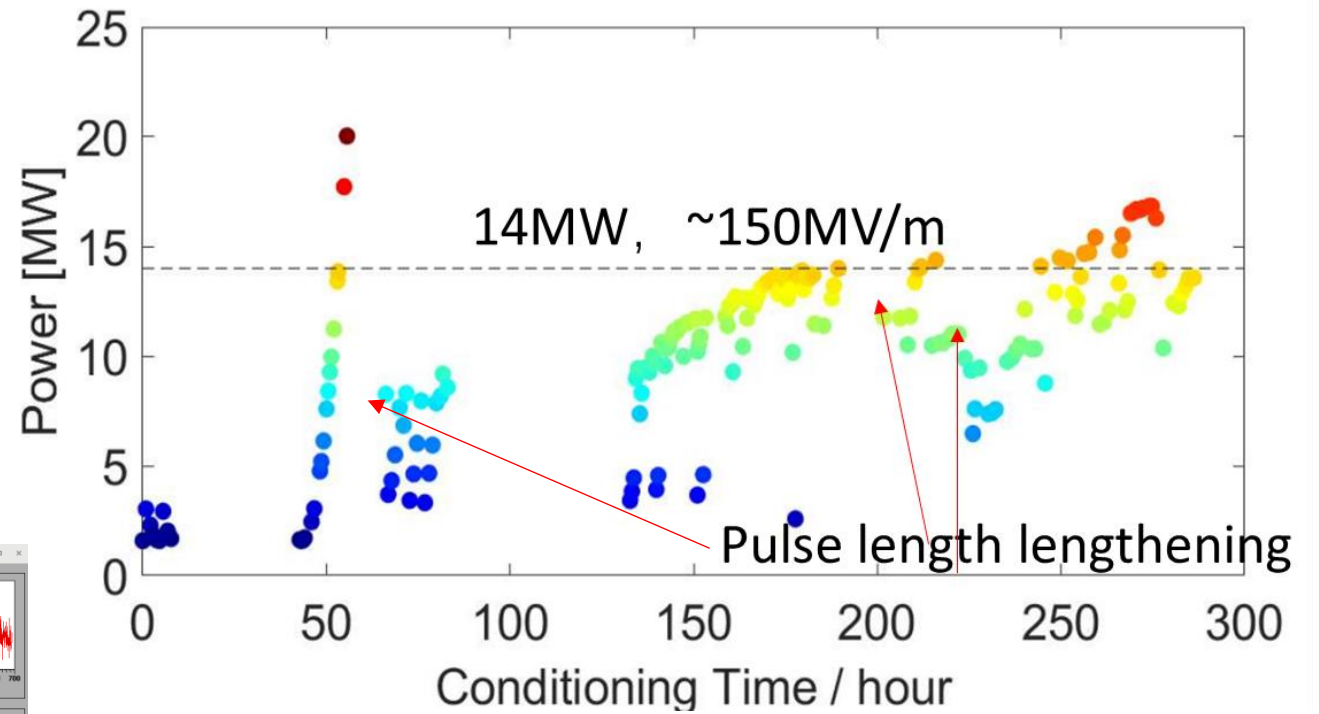

The C-band photocathode gun – Lessons learned

- Lessons learned

First test

First test, Charring of the rubber gasket at the pumping waveguide

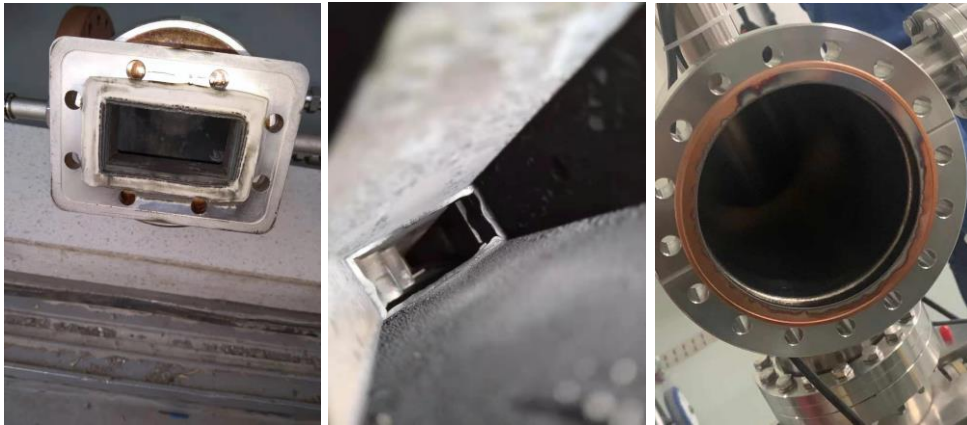

The whole circulator gas area was contaminated.
New circulator and RF windows.
All flanges based on vacuum type, instead of flat flange.

Test Again

Test again, the power level that can be steadily achieved was constantly decreasing.

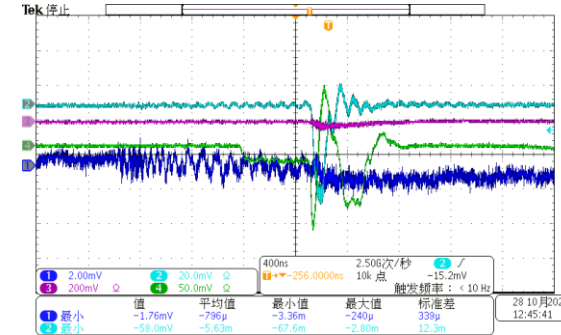

Breakdown of the circulator load

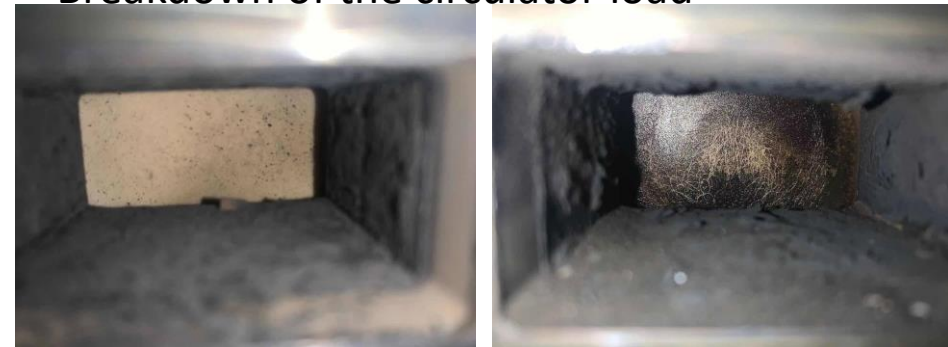

Circulator, above 10MW, Ferrite Powder
Still work on it

The cryogenic C-band Gun – High power test

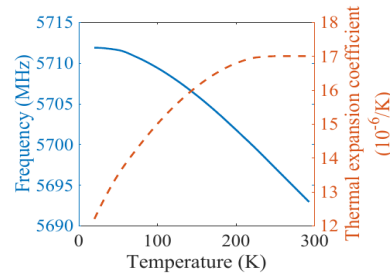
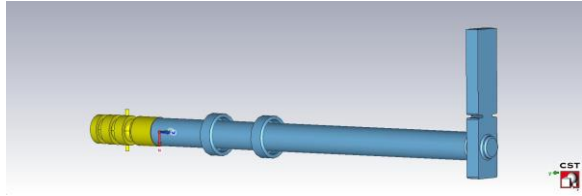

Parameter	Value
Temperature	~20K
Frequency	~5713.7MHz
β	3.088
Required power	5.4MW (200MV/m)
Required rep. rate	<1Hz

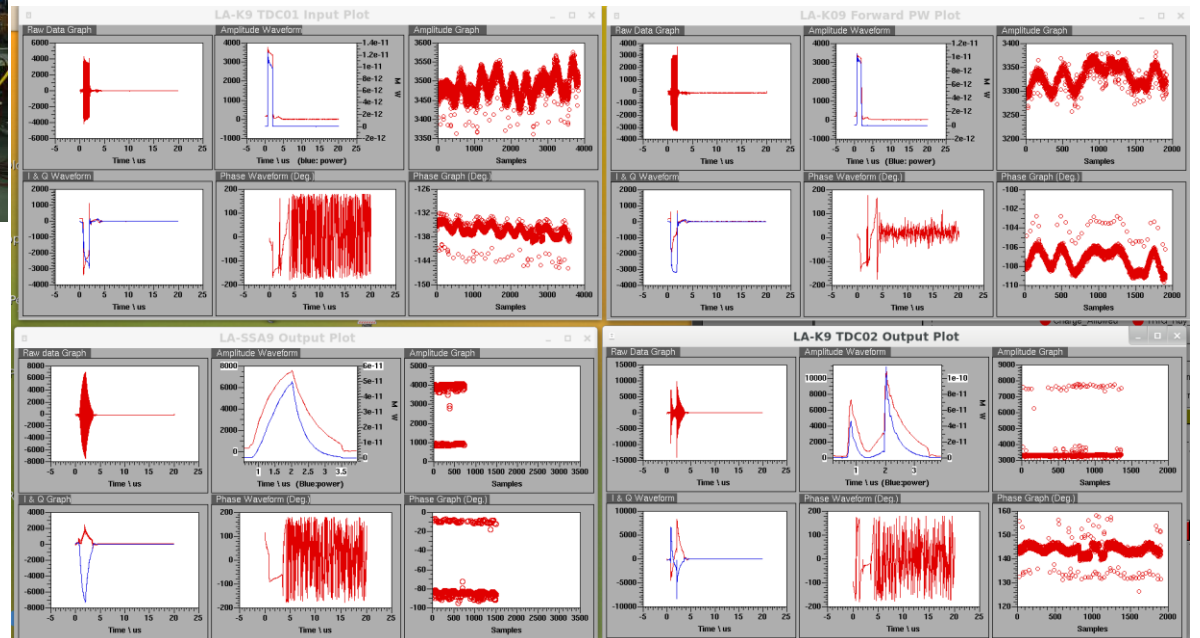
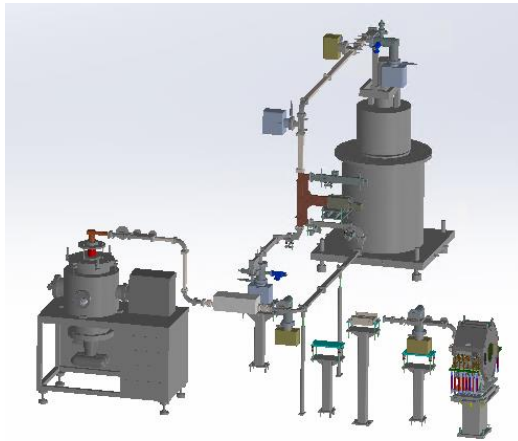

The similar design and layout cooling experiment, reached 20K
 Required 1Hz and 5.4MW

The cryogenic C-band Gun – High power test

Output frequency is tuned to 5713 MHz by LLRF; Repetition rate remained 10Hz; pulse width 1 microsecond.

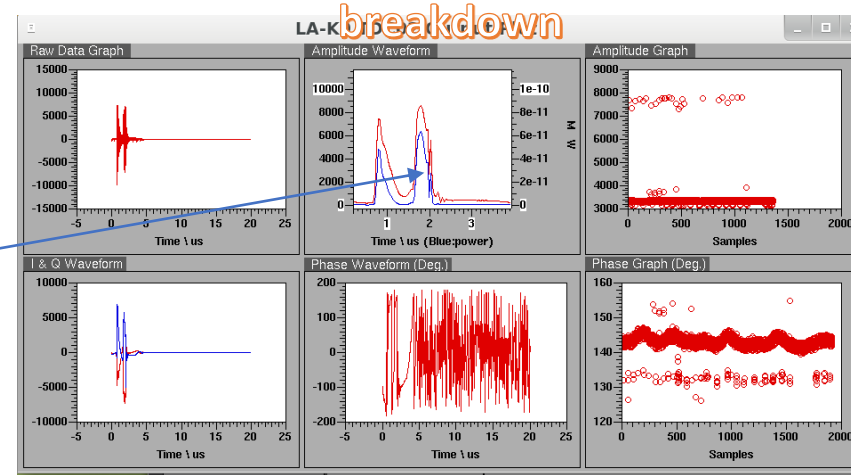
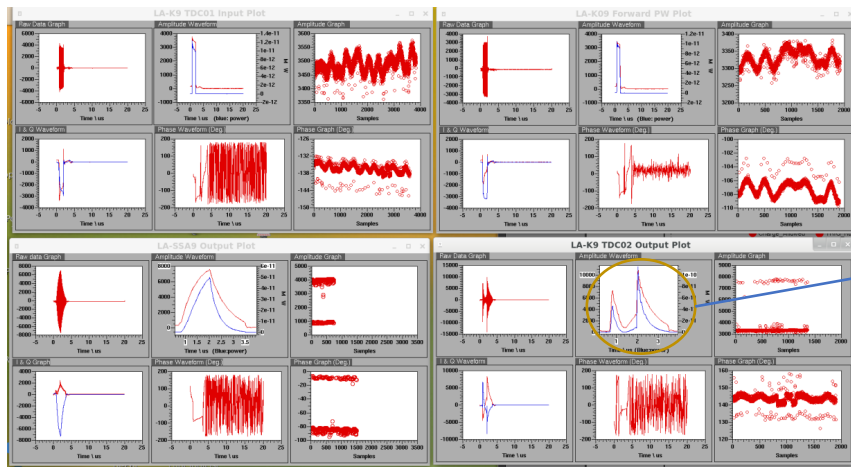

~1.2MW, ~90MV/m

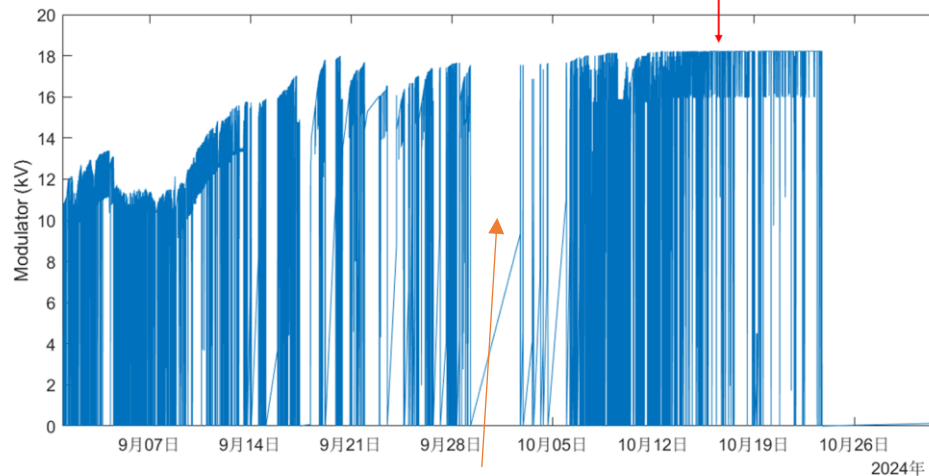

Stop of the SXFEL

1.2MW in the gun, corresponding to 90MV/m
Waveform aberration when power get higher
Accompanied by vacuum degradation
Tried to achieve higher, but don't work
Breakdown during the radiation phase.

The cryogenic C-band Gun – High power test

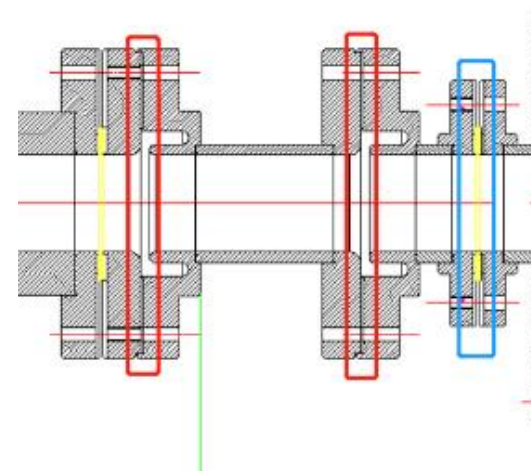
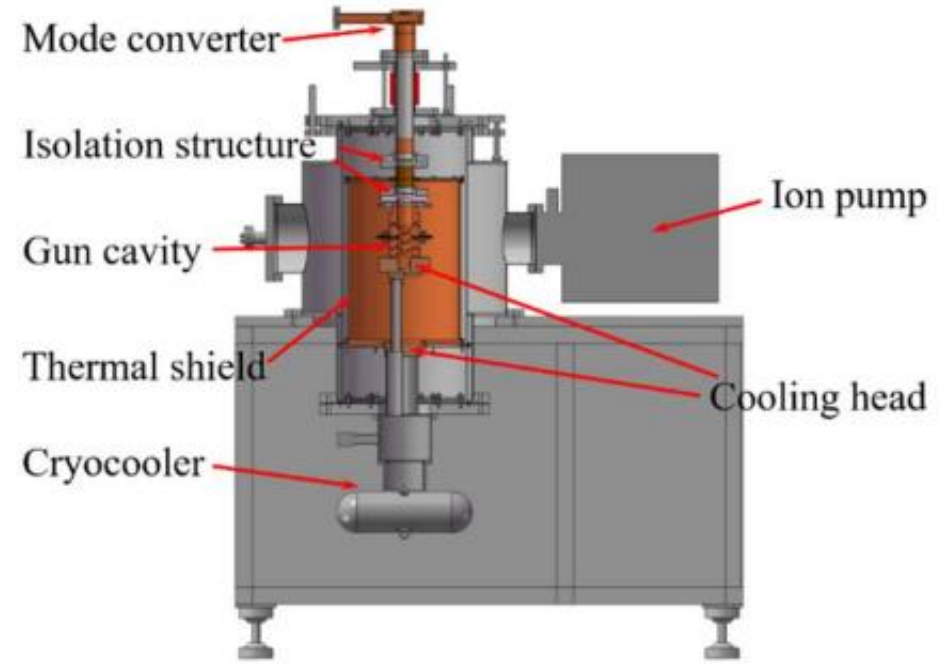
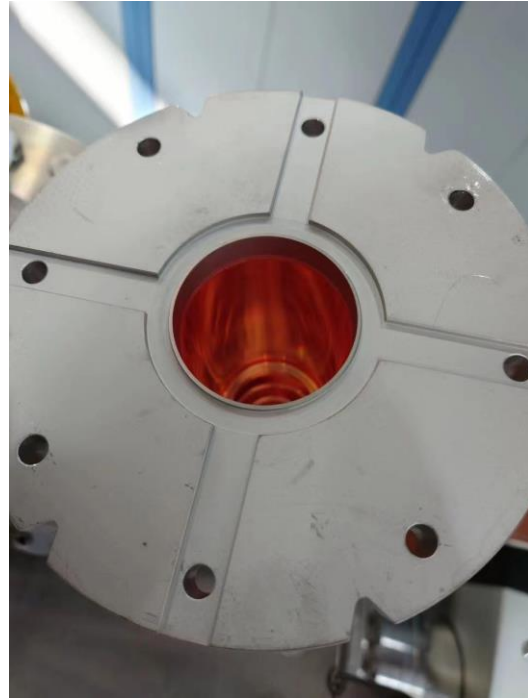
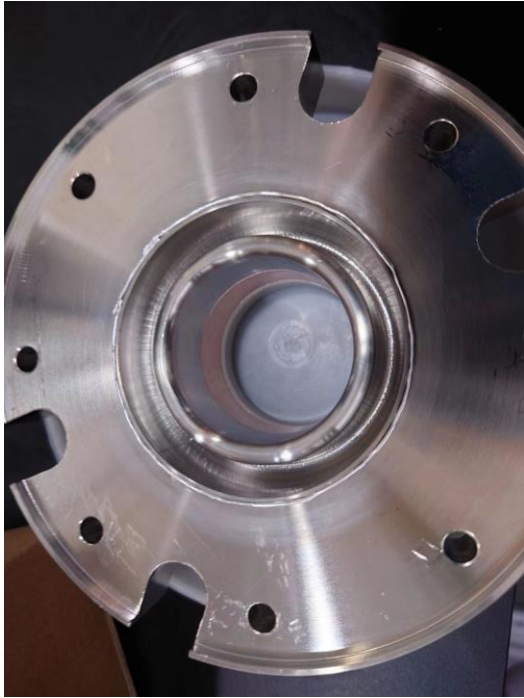

Estimation: The flat flange at the choke cannot be fully sealed (with indium wire).
Remove the choke structure to isolate the internal and external vacuum completely.

Outline

- Background and Review of SXFEL
 - Photoinjector and the requirement of the RF gun
 - The main C-band linac
- The C-band RF gun
 - RF design and beam dynamics of the 3.6-cell gun
 - High power test of the C-band gun
 - The cryogenic gun – design and preliminary high-power test
- **The cryogenic C-band structure**
 - RF design and low-power test
 - Status and plans
- Conclusion

The cryogenic C-band Structure – For higher gradient

$$\Delta T = |H|^2 \sqrt{t_p} \frac{R_s}{\sqrt{\pi \rho c_\epsilon k_h}}$$

$$\Delta T(T) = |H|^2 \sqrt{\frac{2K_s \mu_0}{(1 + \beta) \pi \rho}} \sqrt{\frac{R_s(T)}{k_h(T) c_\epsilon(T)}}$$

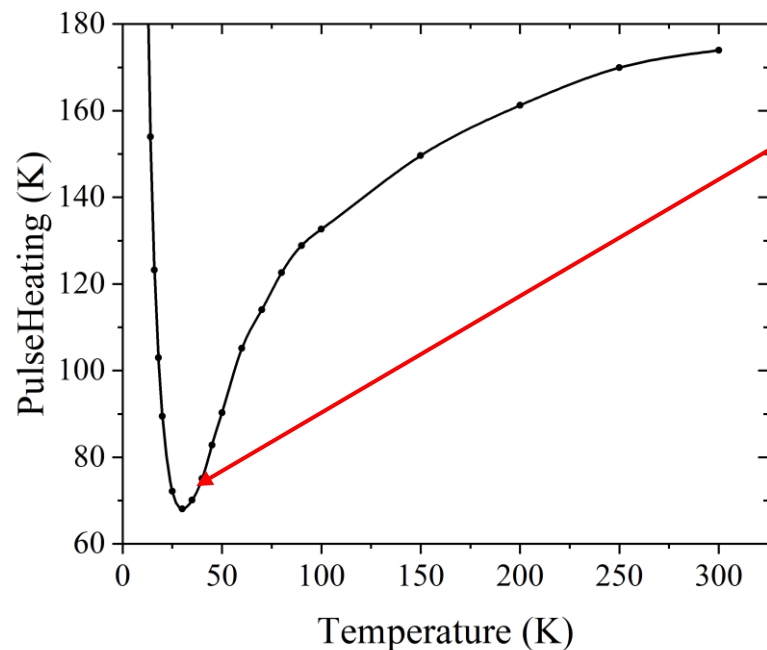

Parameter	Value	Unit
RF frequency	5712	MHz
Working temperature	40	K
Surface resistance@40K	0.005	Ω
Surface resistance@273.15K	0.0188	Ω
The target E_{acc} (SW)	65/80	MV/m
Type of Structure	Bi-periodic	
Operating Mode	SW / $\frac{\pi}{2}$	
Material	Copper	
RRR	300	
Coolant	Liquid helium	

Lower pulse-heating, Less deformation

$$\Delta L(T) = \int_T^{T+\Delta T} \alpha_l(T') \cdot \left(|H|^2 \sqrt{\frac{2K_s \mu_0}{(1 + \beta) \pi \rho}} \cdot \sqrt{\frac{R_s(T')}{k_h(T') c_\epsilon(T')}} \right) dT'$$

Still requires further investigation

The cryogenic C-band Structure – Design

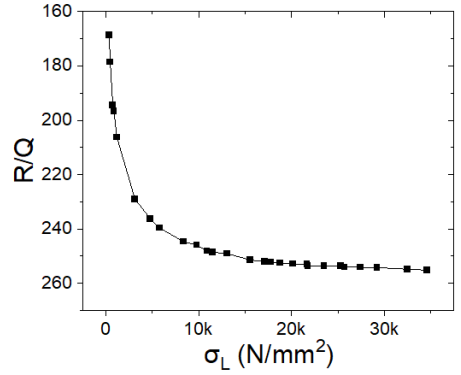
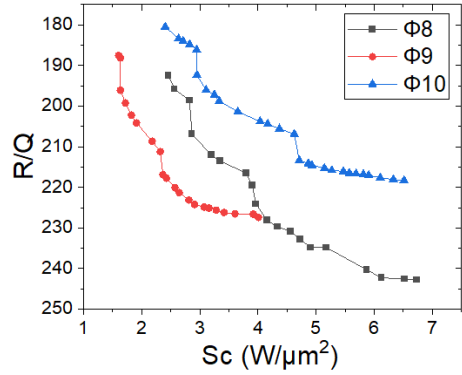

Frequency	5712MHz
Working temperature	40K
Surface resistance@40K	0.005Ω
Surface resistance@273.15K	0.0188Ω
The target E_{acc}	80MV/m
Type of Structure	Bi-periodic
Operating Mode	$\pi/2$
Shunt impedance	501MΩ/m
Q_0 (pill box)	55353
S_c	$2.23W/\mu m^2$
E_{peak}	218MV/m
H_{peak}	168kA/m
$E_{peak}/E_{acc}(\beta_b \approx 1)^1$	2.72

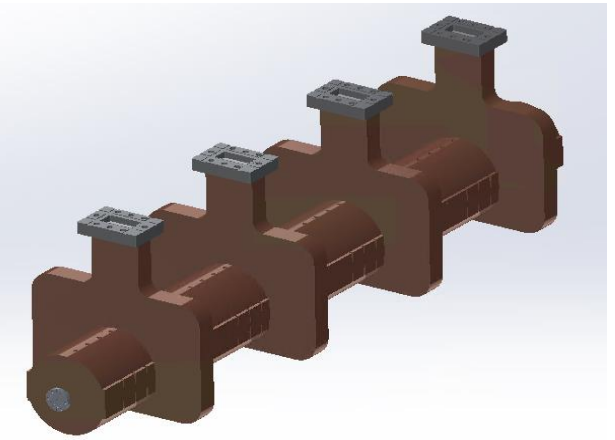

- Bi-period mode (TM01 & TM02-like)
- Alignment of the different cavities
- Transition of the coupling hole after brazing

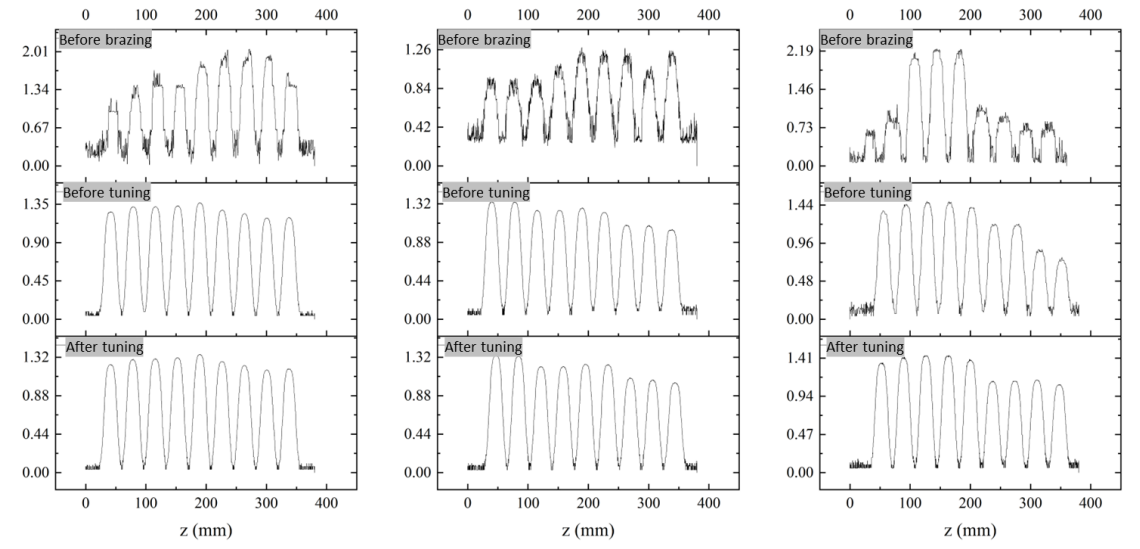
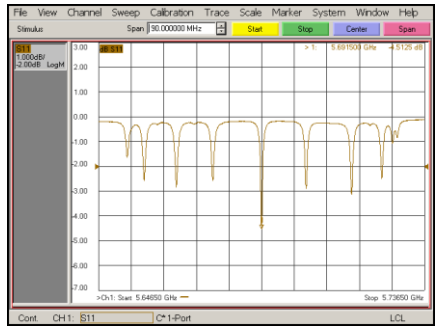
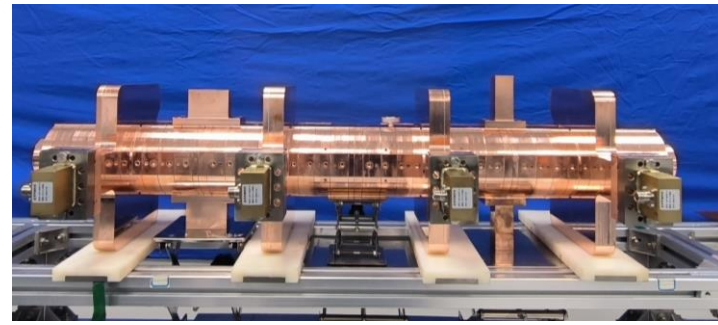

The cryogenic C-band Structure – Low-power test

First cryogenic test: liquid nitrogen

RF performance and cryogenic vacuum leakage resistance verification.

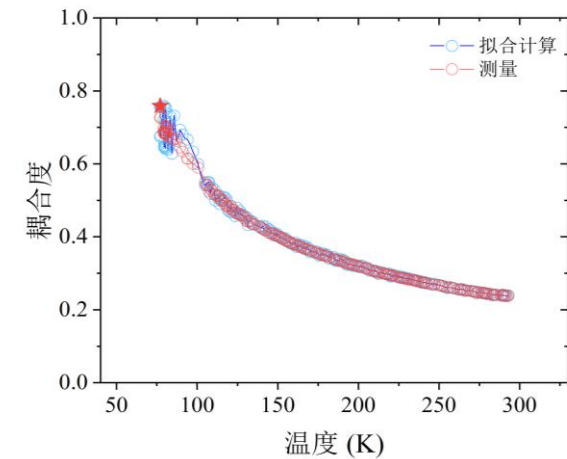
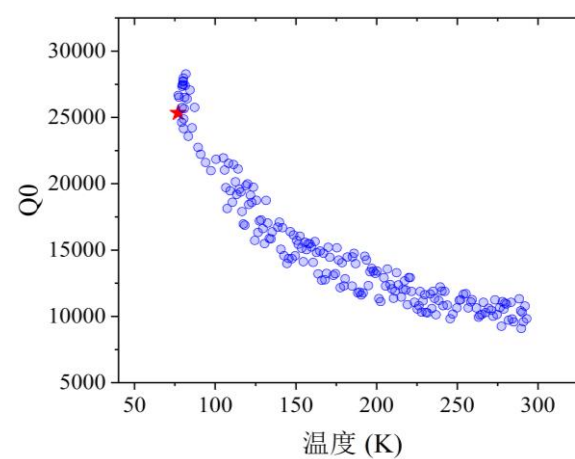
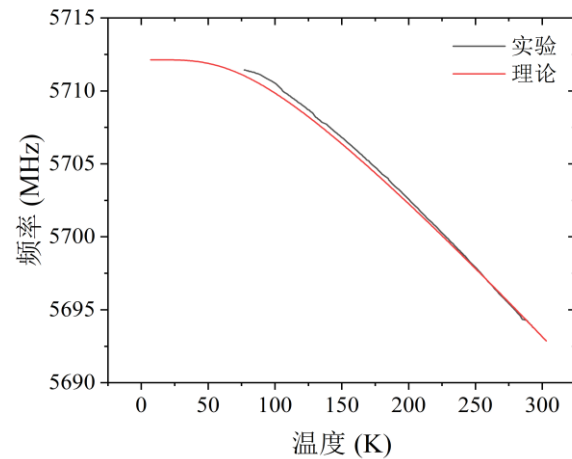

The cryogenic C-band Structure – Cryostat design

	Helium Refrigerator	Stirling refrigerator	G-M refrigerator
Capacity	20K@500W	20K@250W	20K@40W
		40K@600W	30K@80W
Ultimate performance	<20K	<20K	~20K
Power consumption	200KW/380V	45KW/380V	9kW/380V
Price	~1,500,000 USD	~530,000 USD	~60,000 USD

The Helium refrigerator provides the best cooling
 GM system is the most economical option.
 cost savings while maintaining stable environments.

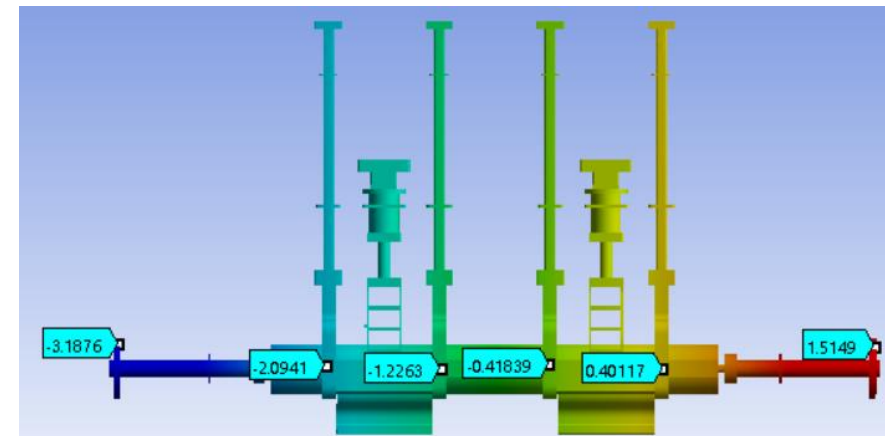
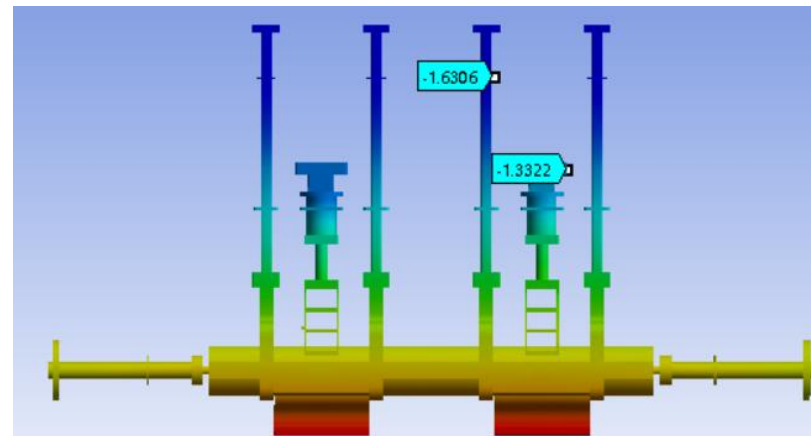
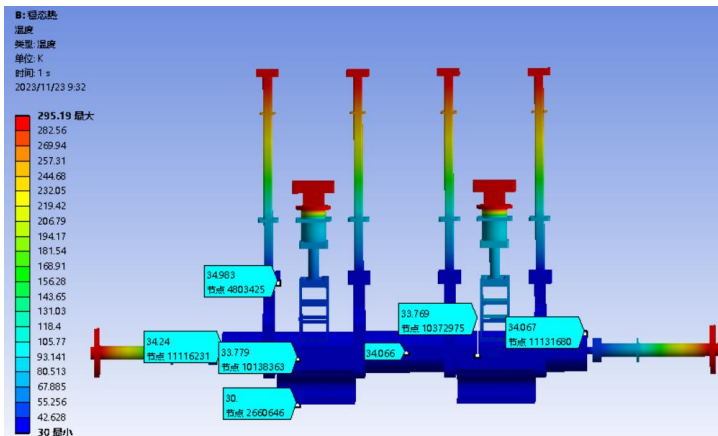
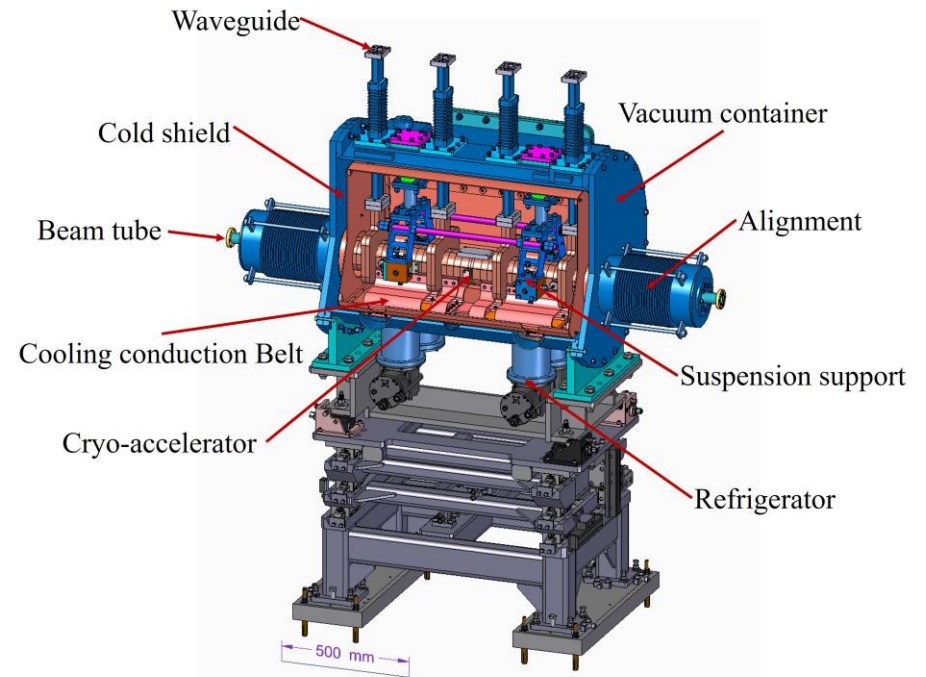

The cryogenic C-band Structure – Present

Measurement and Control
Instrumentation fixed

Thermal insulation layer
wrapping

RF structure suspended and
mounted in the cryostat

→ Vacuum obtained

Starting to cool down

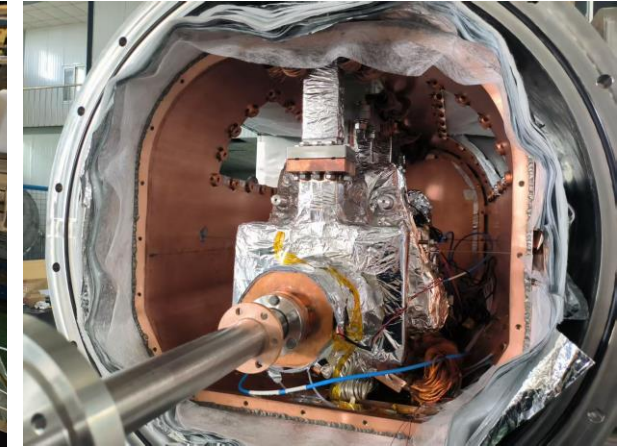

Summary

- We are still gradually improving the performance of the SXFEL accelerator.
- C-band guns will perform better than S-band guns can be verified with the high-power test
- Still require further high-power test and beam test
- The preliminary high power experiments cryogenic electron gun show some problems, and will be specifically analyzed during summer maintenance.
- Design, fabrication and integration of the cryogenic structure has been completed and high power testing will be completed in the near future.



Thank you for your attention