

PSI

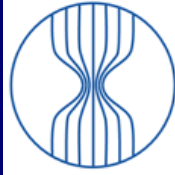

HFM
High Field Magnets
Programme



Sub Scale Stress-Managed Common-Coils

Preliminary testing results

D. Araujo, B. Auchmann, A. Brem, T. Michlmayr, C. Müller, A. Stampfli and A. Haziot (CERN)
PSI, 18 July 2024

Work packages overview – KE5943



HFM
High Field Magnets
Programme



PSI

RD Line	Work Package	Tasks, deliverables	TASK/DELIVERABLE DESCRIPTION
RD2	RD2	RD2	HTS Conductors and HTS Magnet Technologies
RD2	WP2.19	WP2.19	R&D relating to HTS technology - PSI/CHART collaboration KE5943
RD2	WP2.19	D2.1	HTS Roadmap Conceptual Report
RD2	WP2.19	D2.2	ReBCO Cable Test Report
RD2	WP2.19	D2.3	Technology Racetrack Test Report
RD3	RD3	RD3	Nb3Sn Magnets
RD3	WP3.14	WP3.14	R&D relating to LTS technology - PSI/CHART collaboration KE5943
RD3	WP3.14	D1.1	BOX Powered-Sample Test Report
RD3	WP3.14	D1.2	SMCC Sub-scale Test Report
RD3	WP3.14	D1.3	SMCC Ultimate-Field Demonstrator Conceptual Design Report
RD3	WP3.14	D1.4	SMCC Ultimate-Field Demonstrator Technical Design Folder
RD3	WP3.14	D1.5	Reel-to-reel Inspection and 10-Stack Characterization of Cables as Received

This presentation

SSSMCC1

Subscale Stress-Managed Common-Coils (SubSMCC) | Acknowledgment



HFM
High Field Magnets
Programme

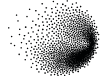

PSI

CHART: B. Auchmann, A. Brem, T. Michlmayr, C. Müller, J. Schmidt, A. Stampfli

LBNL: D. Arbelaez, I. Pong, P. Ferracin, S. Prestemon (Nb₃Sn cable)

CERN: E. Ravaioli, A. Verweij (protection studies)

CERN: T. Boutboul, S. Hopkins, A. Bonasia (Ic measurements from witness samples)

CERN: G; Wilering, F-J. Mangiarotti, J-L Guyon, C. Petrone, J. Feuvrier, S. Russenschuck (testing, magnetic measurement)

CERN: F-O. Pincot, J-C. Perez, A. Haziot, E. Todesco (reaction of two coils out of 4)

CERN: L. Gentini (magnet integration into the cryostat)

Agenda

- Magnet Parameters and Assumptions
- 1st cool-down test results (G. Wilering)

Subscale Stress-Managed Common-Coils (SubSMCC)



HFM
High Field Magnets
Programme



Validating **manufacturing process** and introducing advanced concepts: **coil pre-load free**, at room temperature; stress-management structure and **splicing on the low-field region**.

Fast turn-around platform for testing matrix systems; protection concepts and cooling options.

Possibility to test a Hybrid magnet with LTS (Nb₃Sn) Common-Coils and HTS racetracks

LTS (Nb₃Sn) conductor manufactured by LBNL (cct subscale cable)

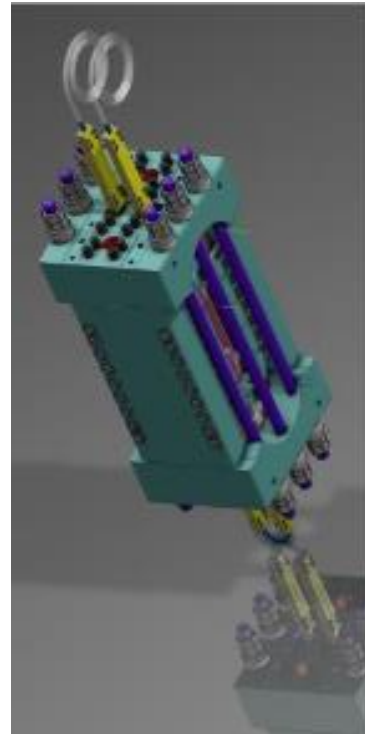
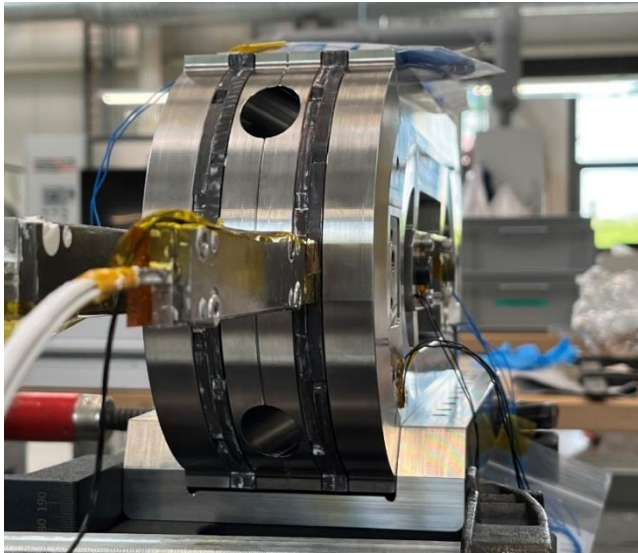

Number of turns	Wire type	N wire x dia in mm	Cu/nCu	Bare Cable dimension s in mm	Insulation thickness in mm
18 / layer	Nb ₃ Sn RRP® 132/169	11 x 0.6	1.17	3.8 x 1.3	0.155

T _{op}	I _{ss}	B _{peak} in T	B ₀ in T	J _{sc} in kA/mm ²	J _{cu} in kA/mm ²	J _{ov} ** in kA/mm ²
4.3 K	9.0 kA	6.1	5.0	6.5	5.6	1.4

** Including insulation area

Assumptions and load line

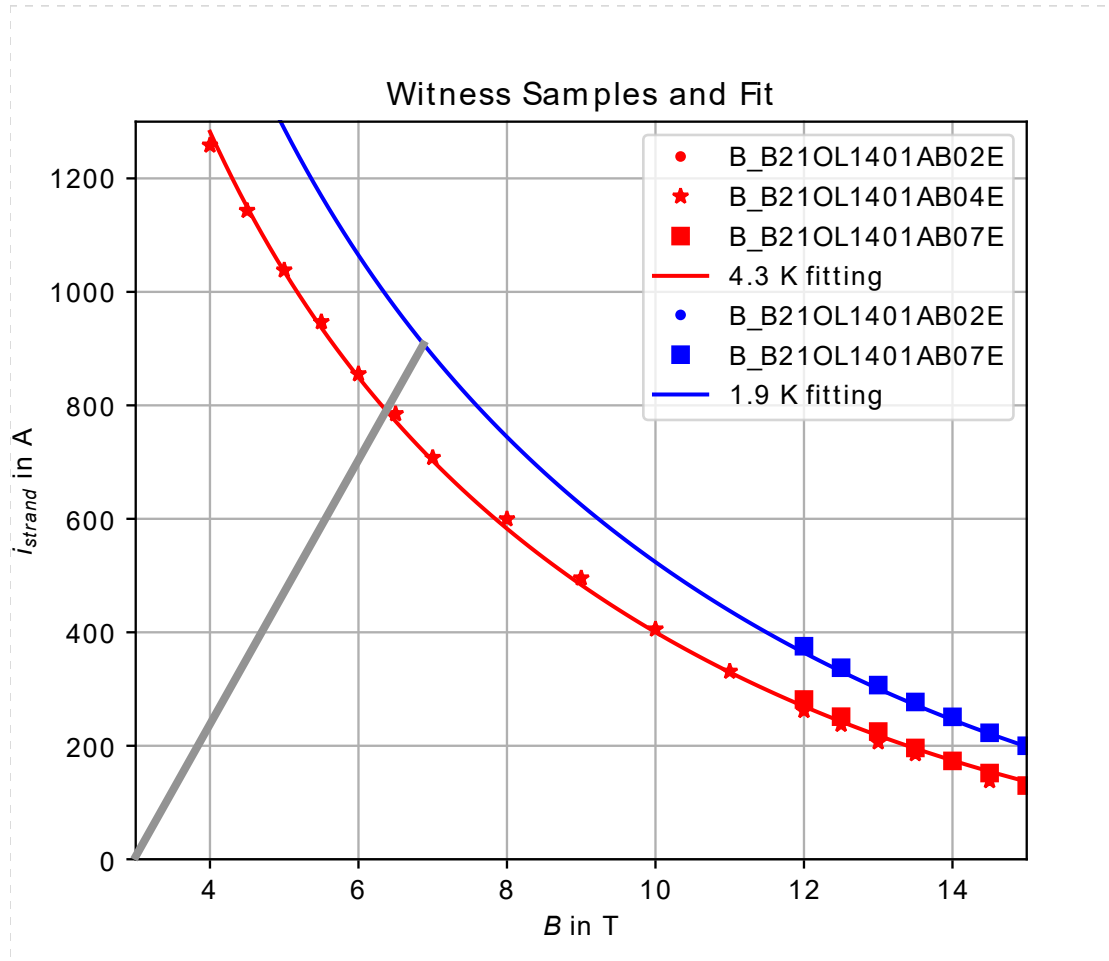

Parameter	CCs 4.3 K short sample values	CCs 1.9 K short sample values
B_{0_ss} in T	5.0	5.5
B_{peak_ss} in T	6.1	6.8
I_{ss} in kA	9.0	10.0

Data based on the extracted wire measurements

Instrumentation: Nomenclature of voltage taps (former 1)



HFM
High Field Magnets
Programme

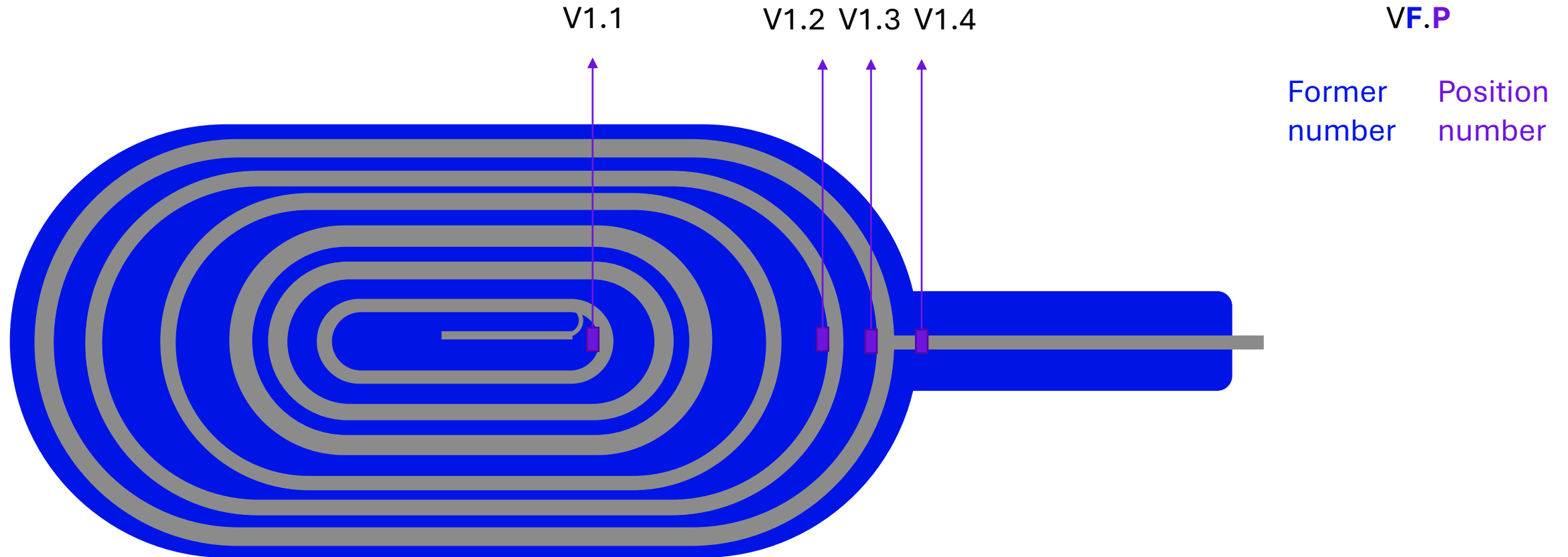

Instrumentation: Nomenclature of parts

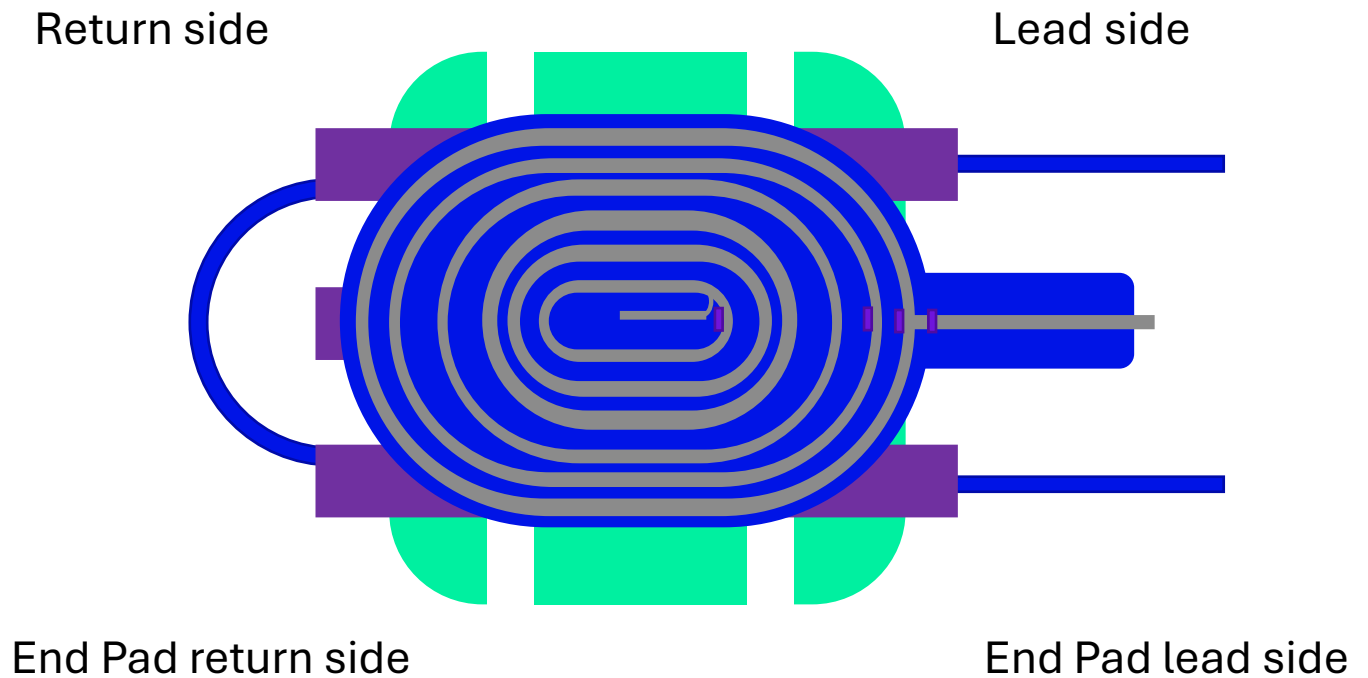
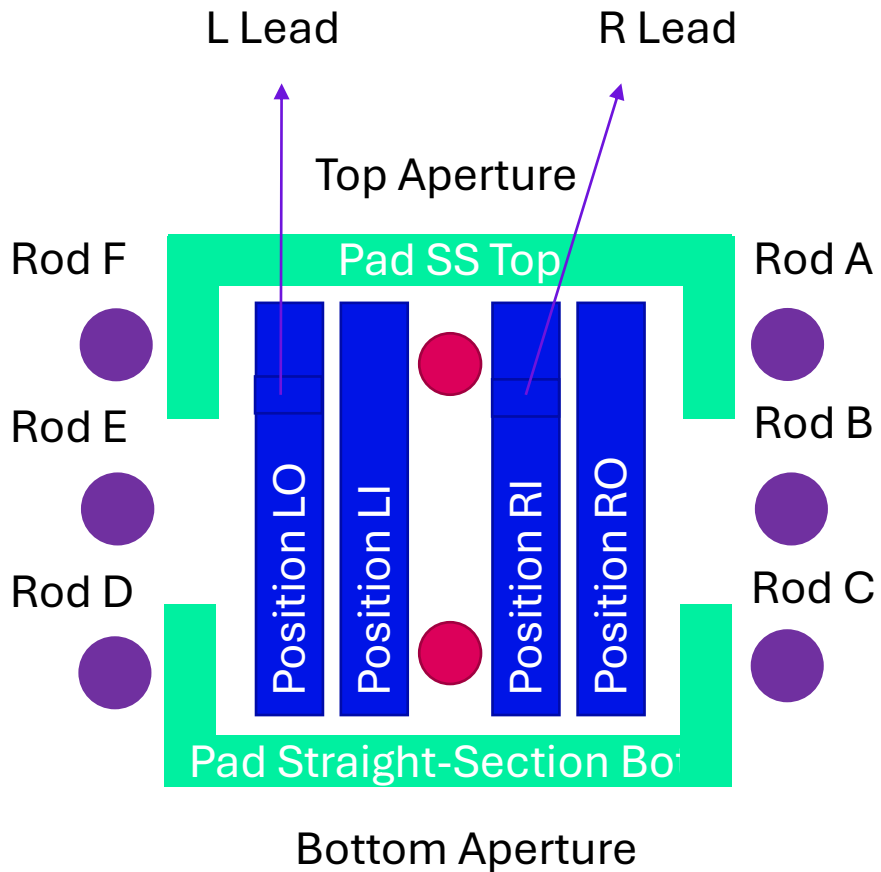

Instrumentation: Nomenclature of parts

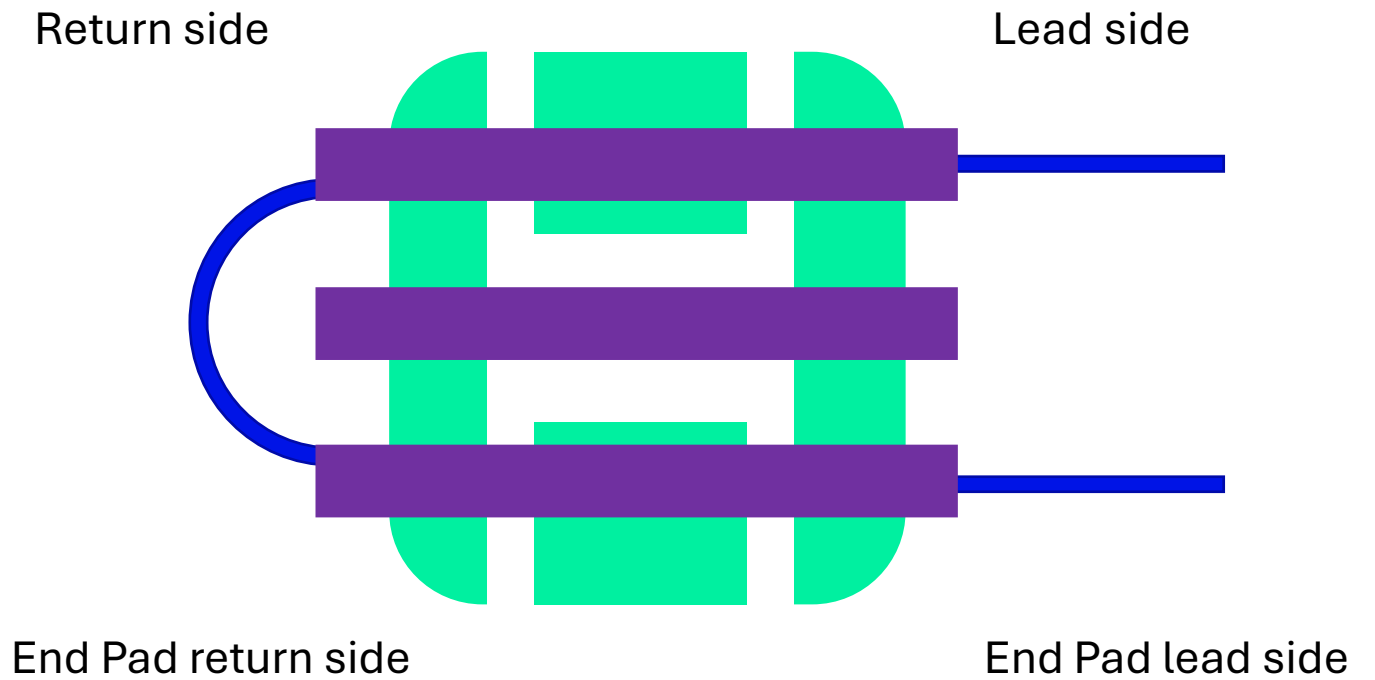
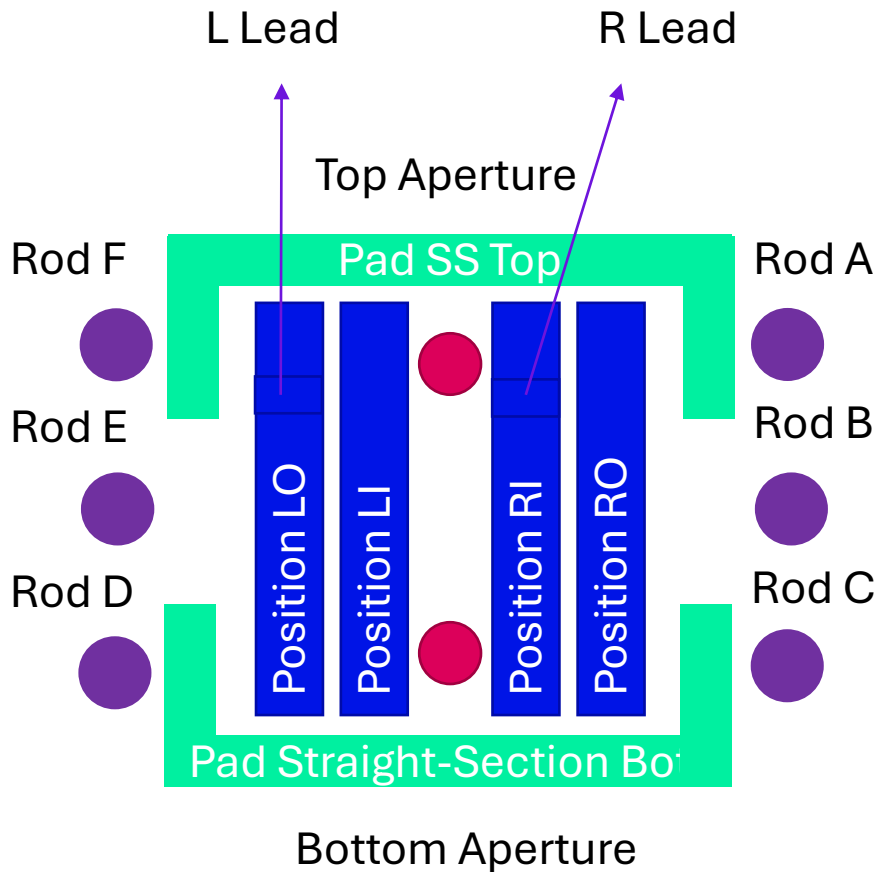

Instrumentation: voltage taps pairs

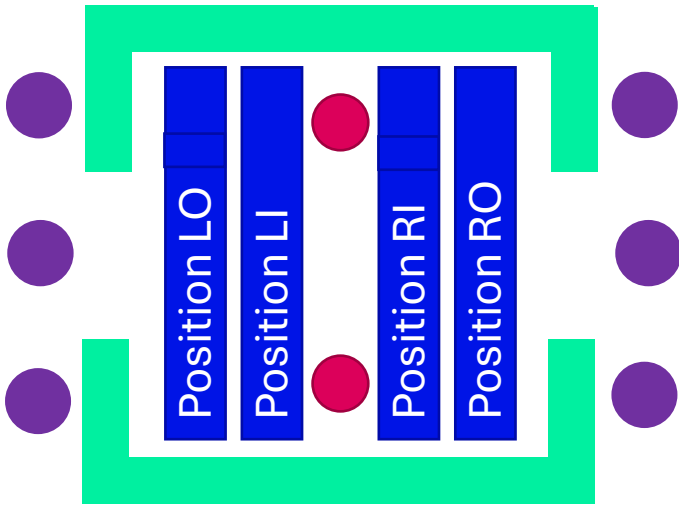

Test configuration

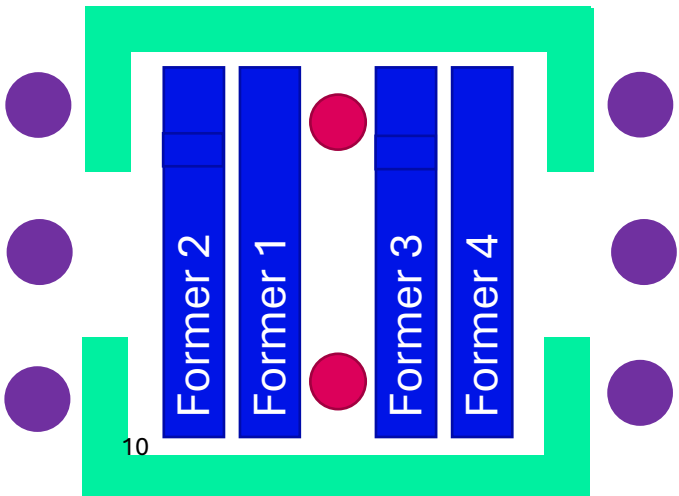

10

Twisted Pairs

Right Side Left Side

V3.4 – V3.3 V1.4 – V1.3

V3.3 – V3.2 V1.3 – V1.2

V3.2 – V3.1 V1.2 – V1.1

Layer jump V3.1 – V4.1 V1.1 – V2.1

V4.1 – V4.2 V2.1 – V2.2

V4.2 – V4.3 V2.2 – V2.3

V4.3 – V4.4 V2.3 – V2.4

Return Side V_{tot}

V4.4 – V1.4 V3.4 – V2.4

Magnet Structure: V MS

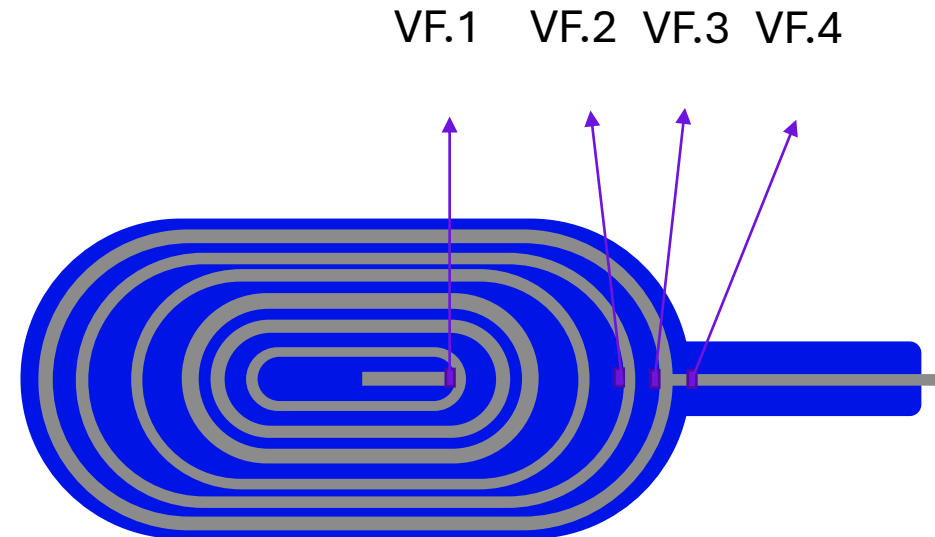

VF.P

Former tap
number Position

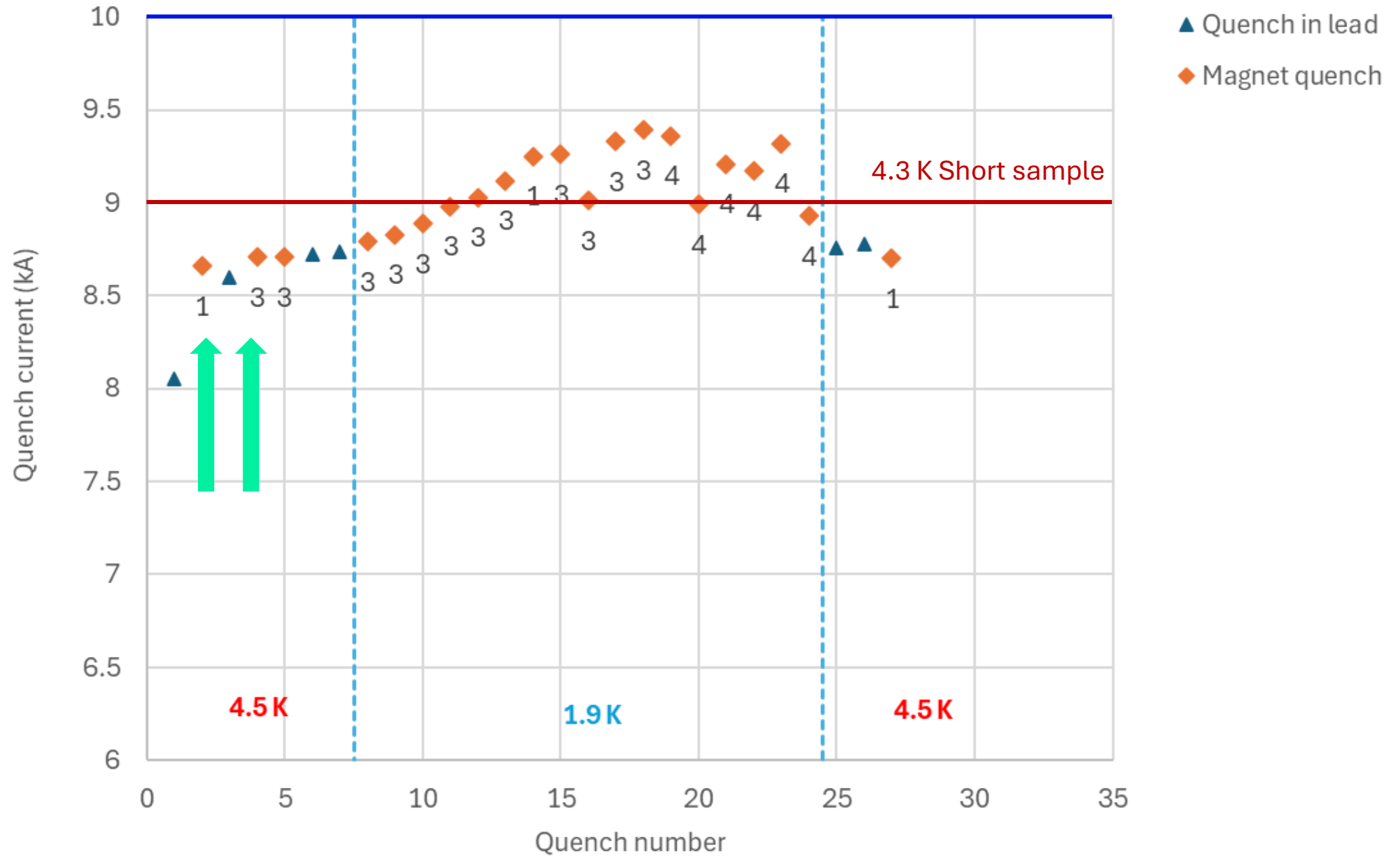

Event 2: 1st CD - 4.5 K – I_{max} = 8.66 kA | Coil 1



HFM
High Field Magnets
Programme

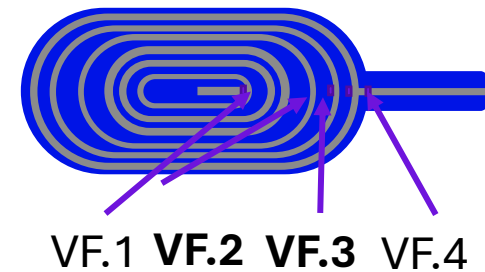
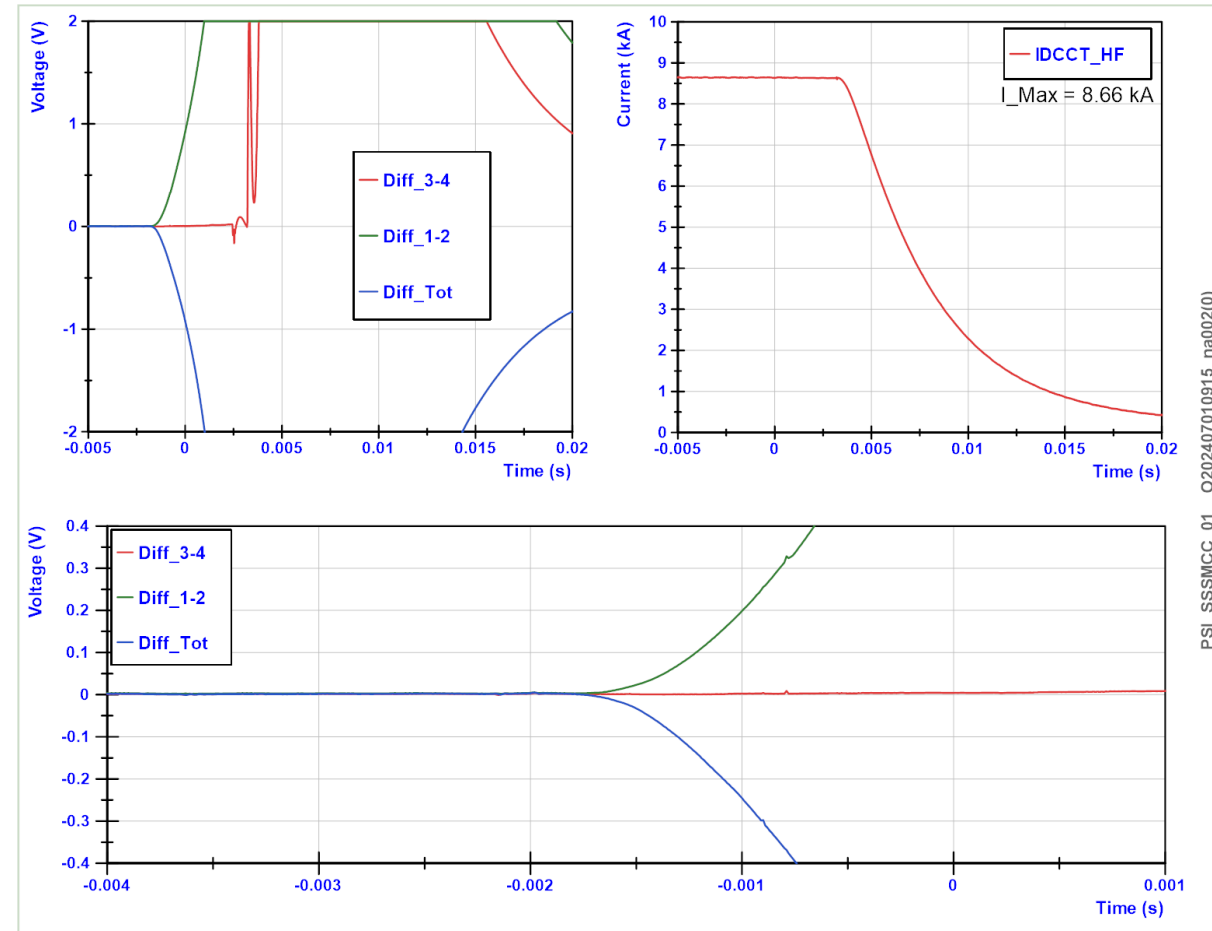
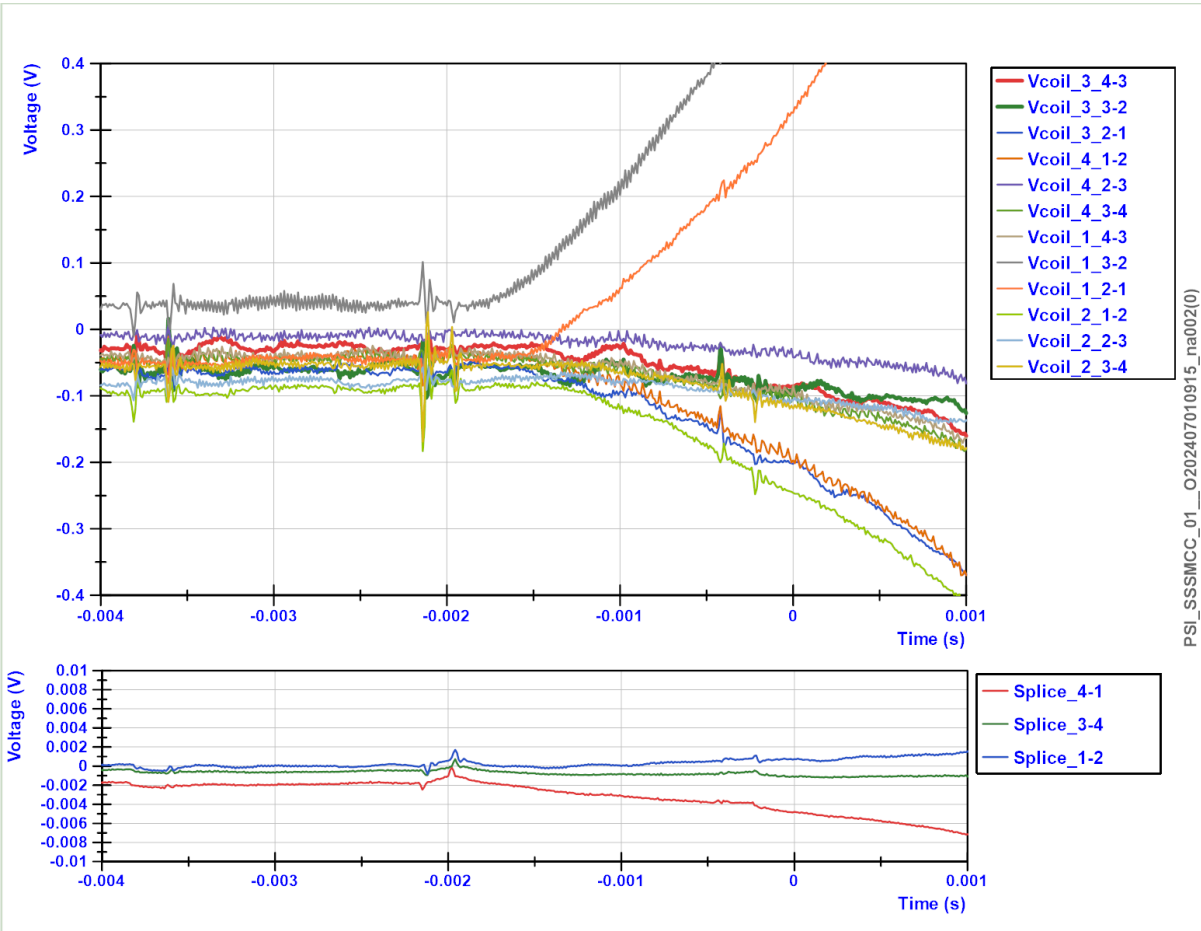

Event 4: 1st CD - 4.5 K – I_{max} = 8.71 kA | Coil 3



HFM
High Field Magnets
Programme



PSI

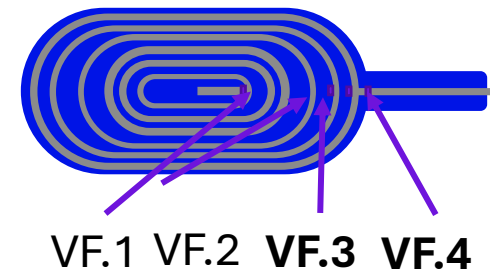
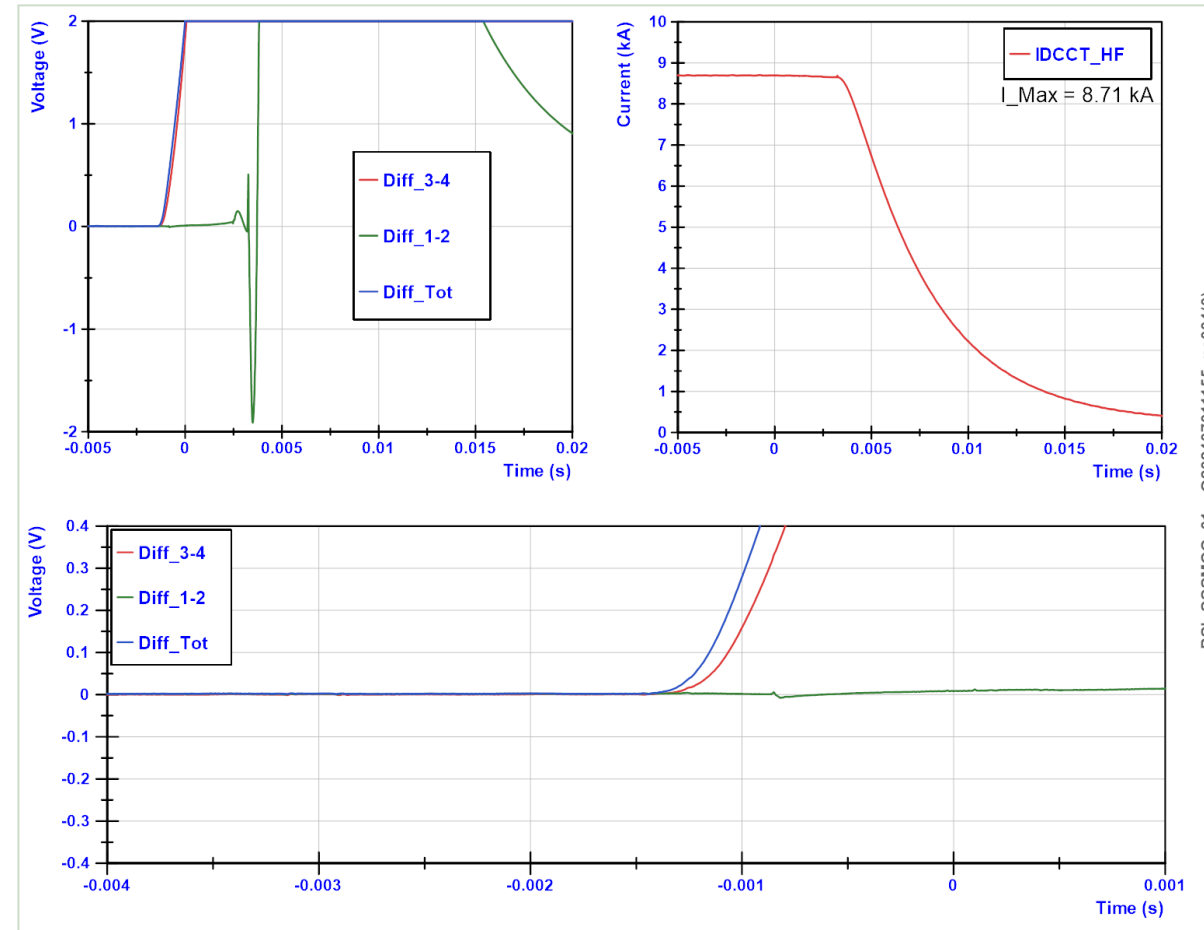
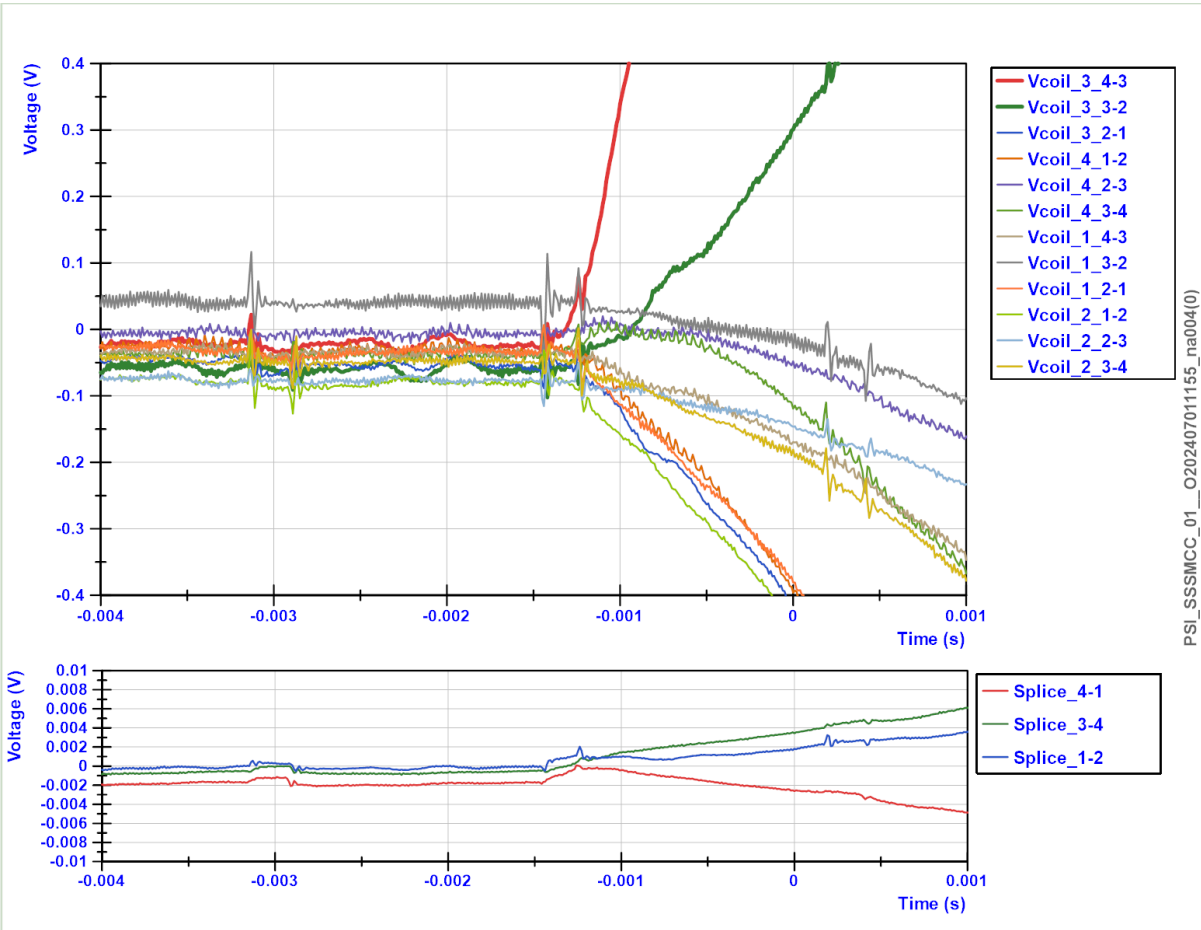

PSI-SSSMCC01 - CD1 1.9 K Short sample

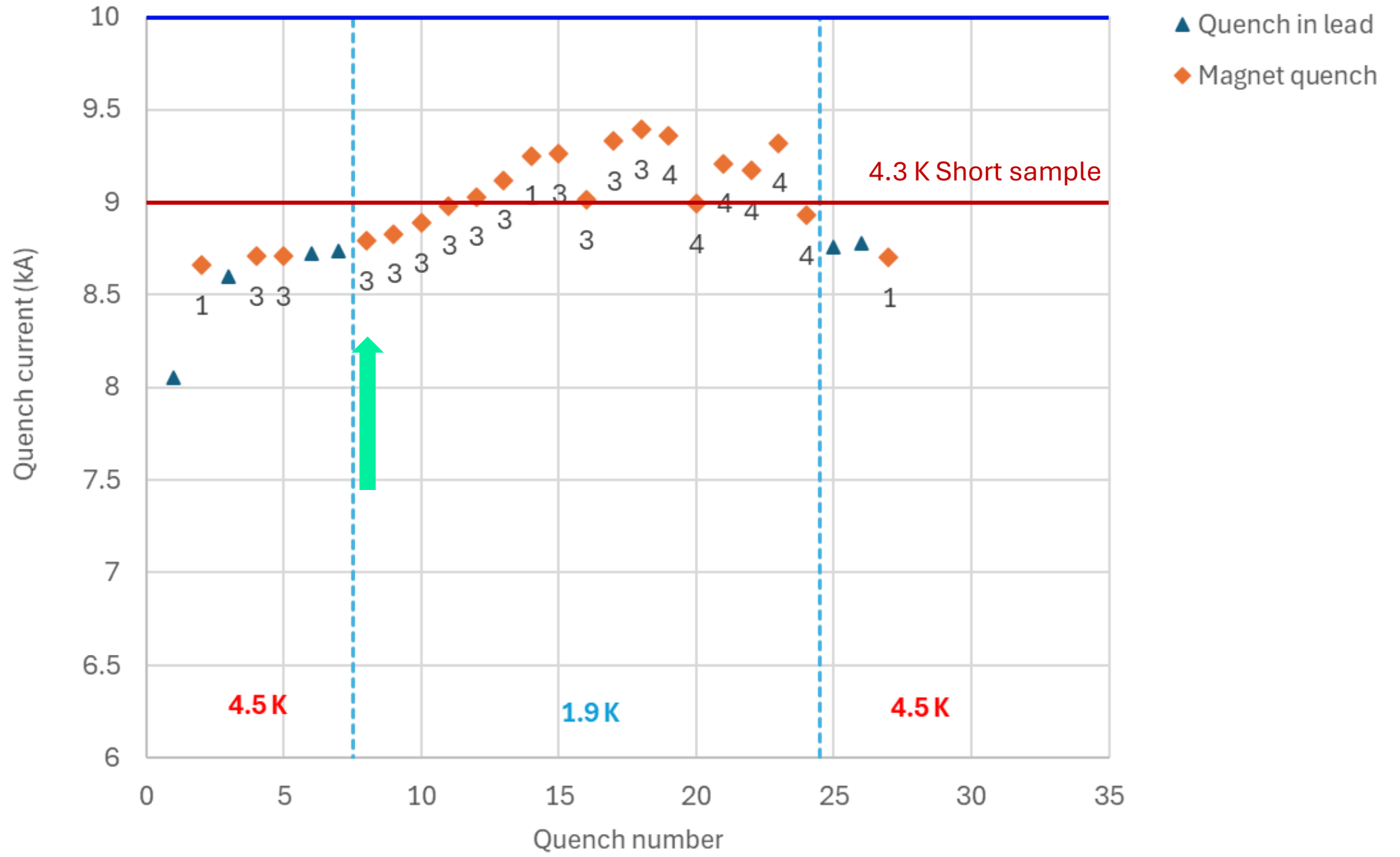

Event 8: 1st CD - 1.9 K – I_{max} = 8.79 kA | Coil 3



HFM
High Field Magnets
Programme

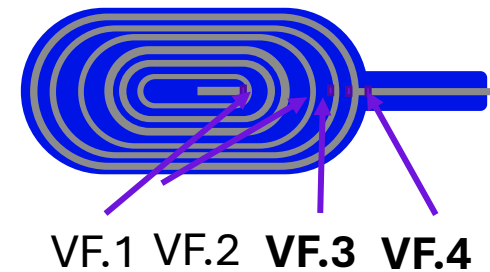
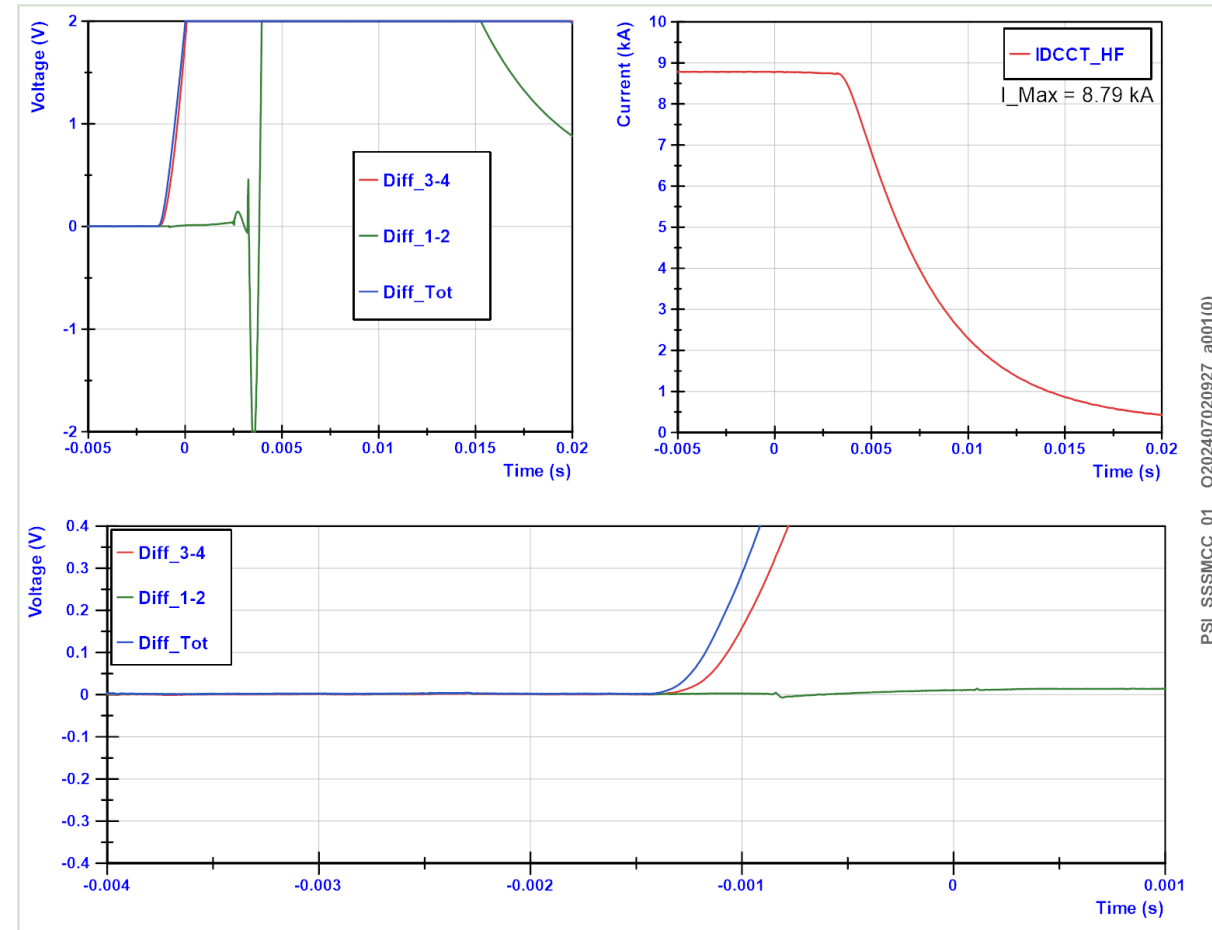
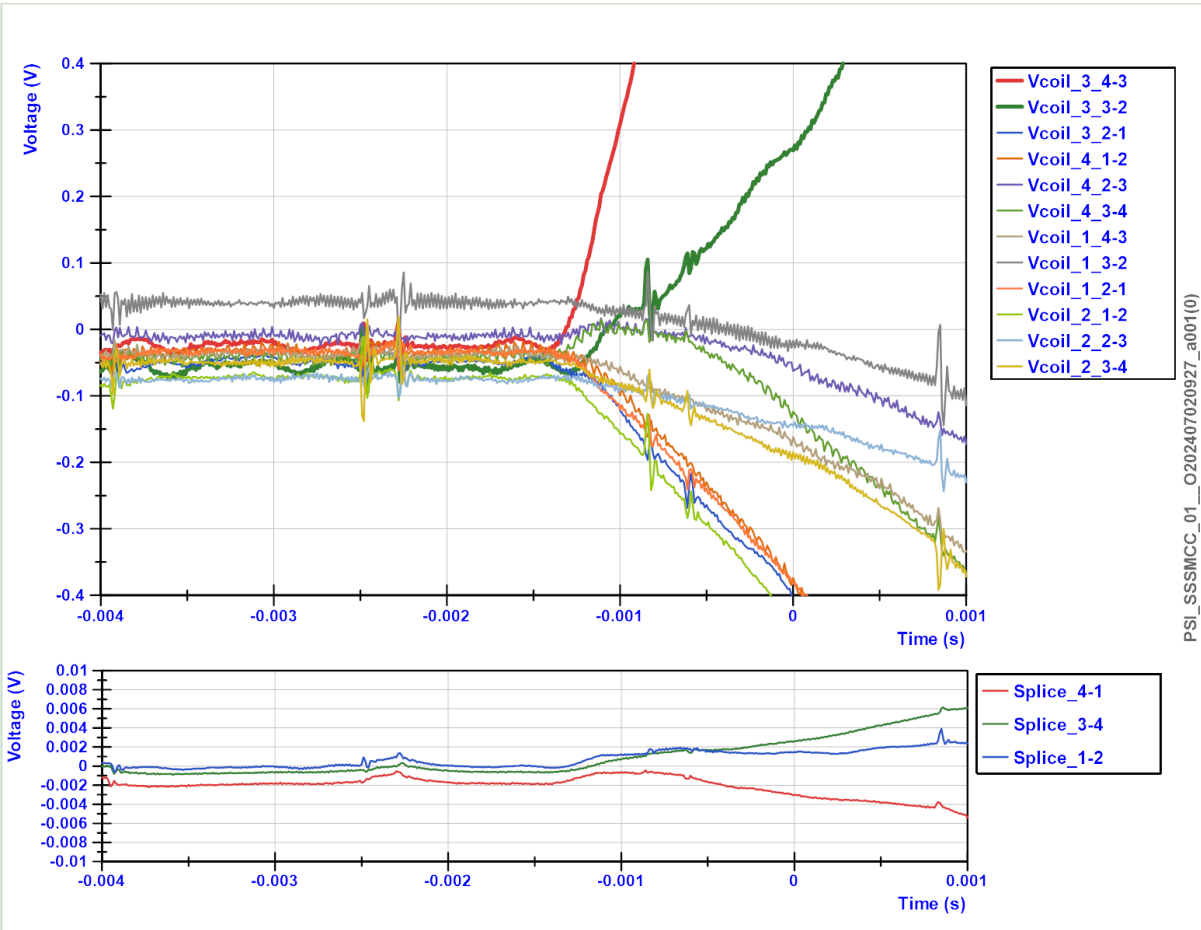

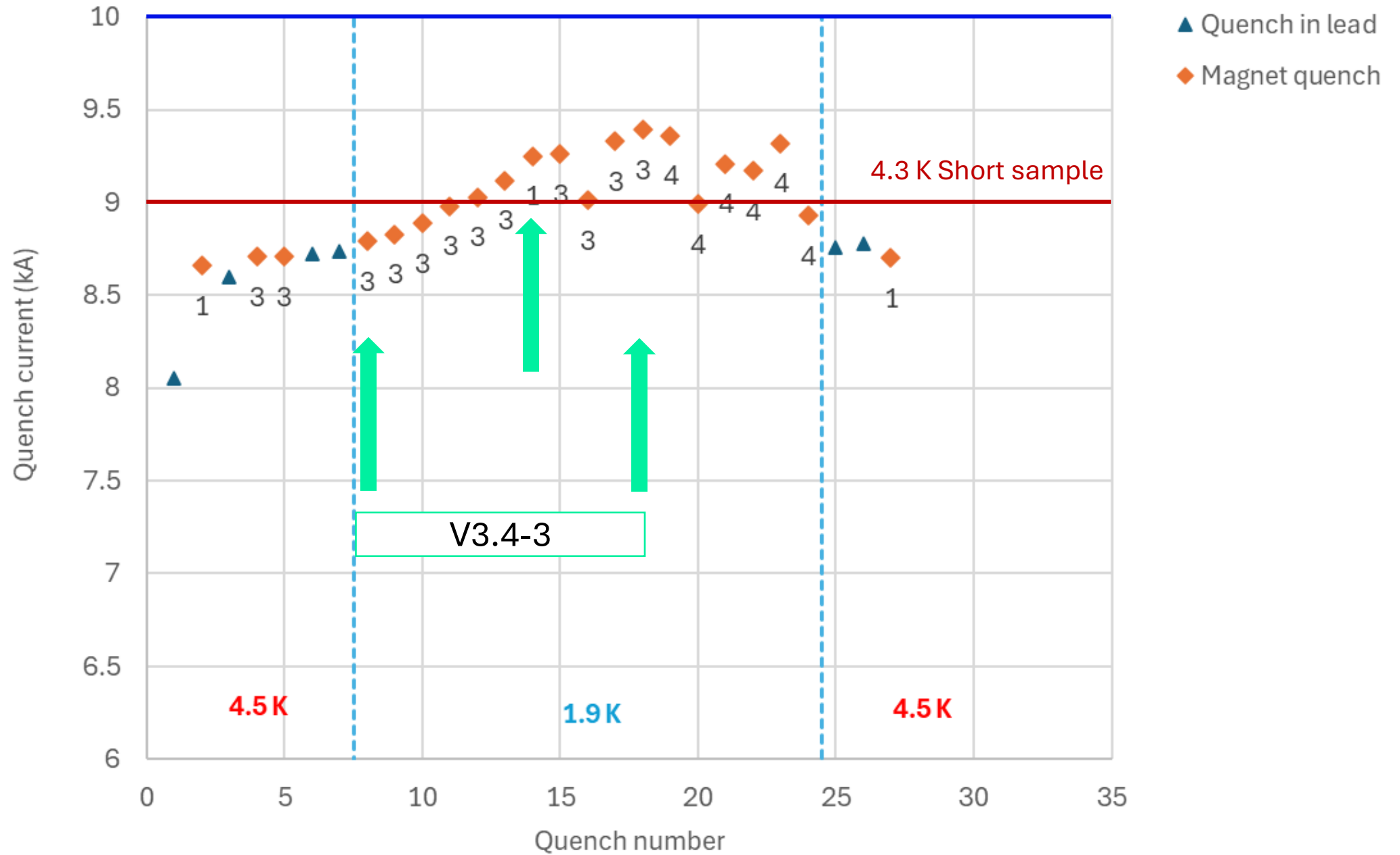

Event 14: 1st CD - 1.9 K – I_{max} = 9.25 kA | Coil 3



HFM
High Field Magnets
Programme

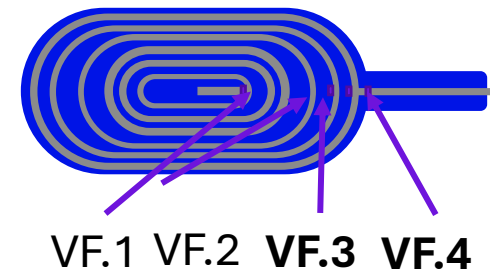
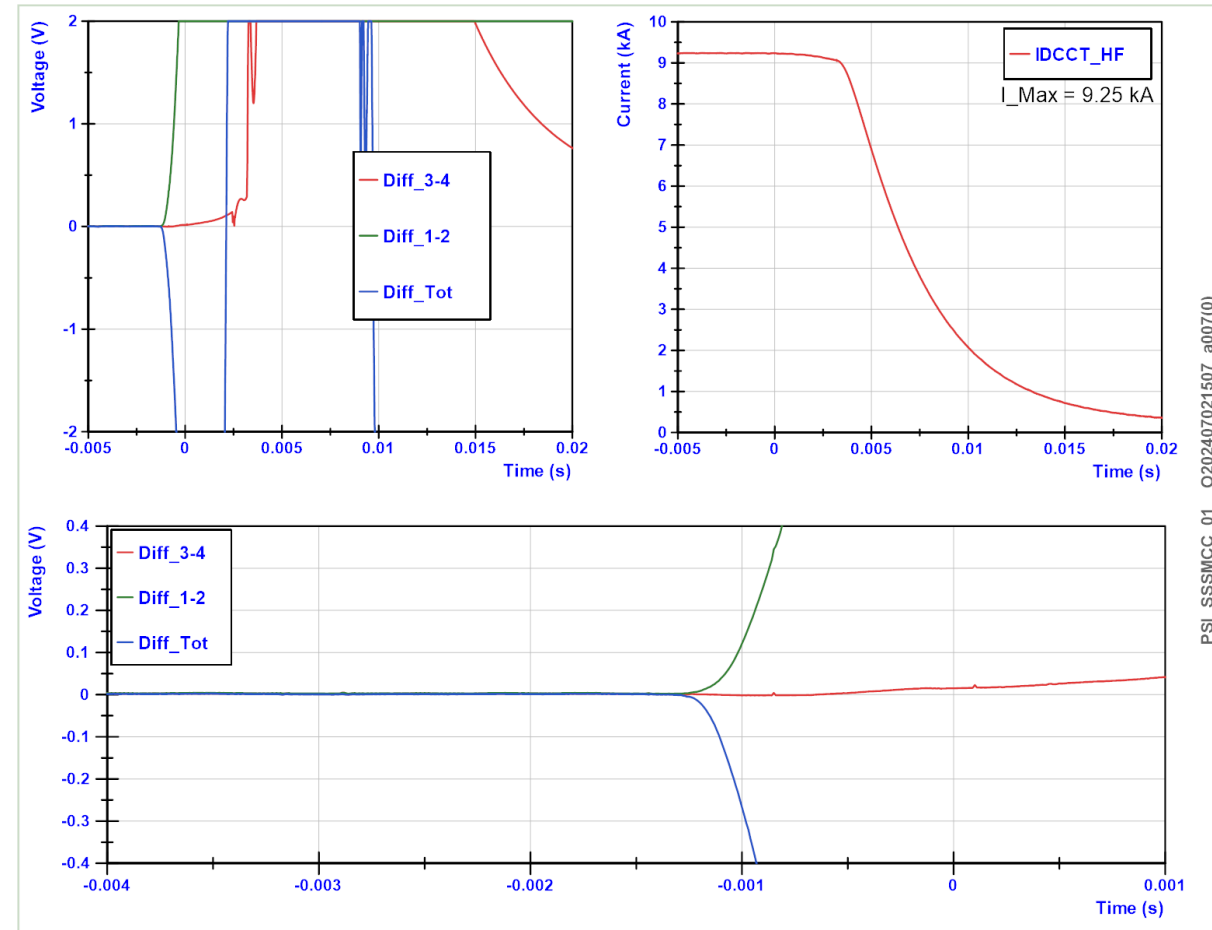
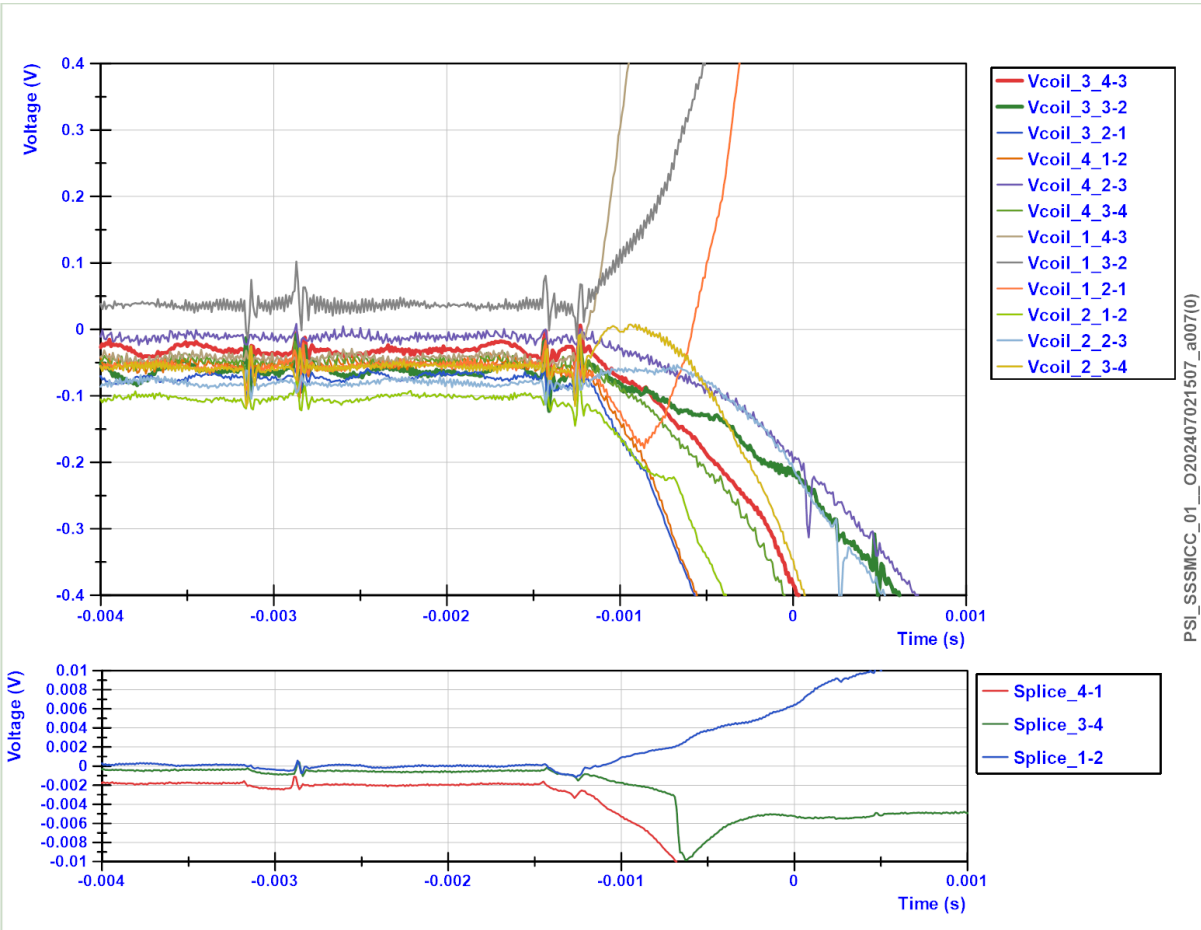

Event 18: 1st CD - 1.9 K – I_{max} = 9.39 kA | Coil 3



HFM
High Field Magnets
Programme



PSI

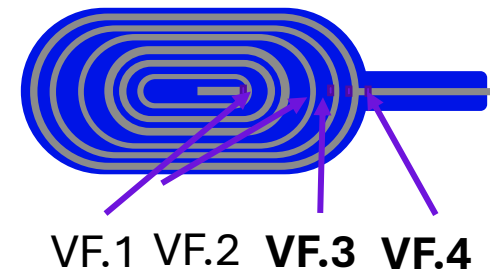
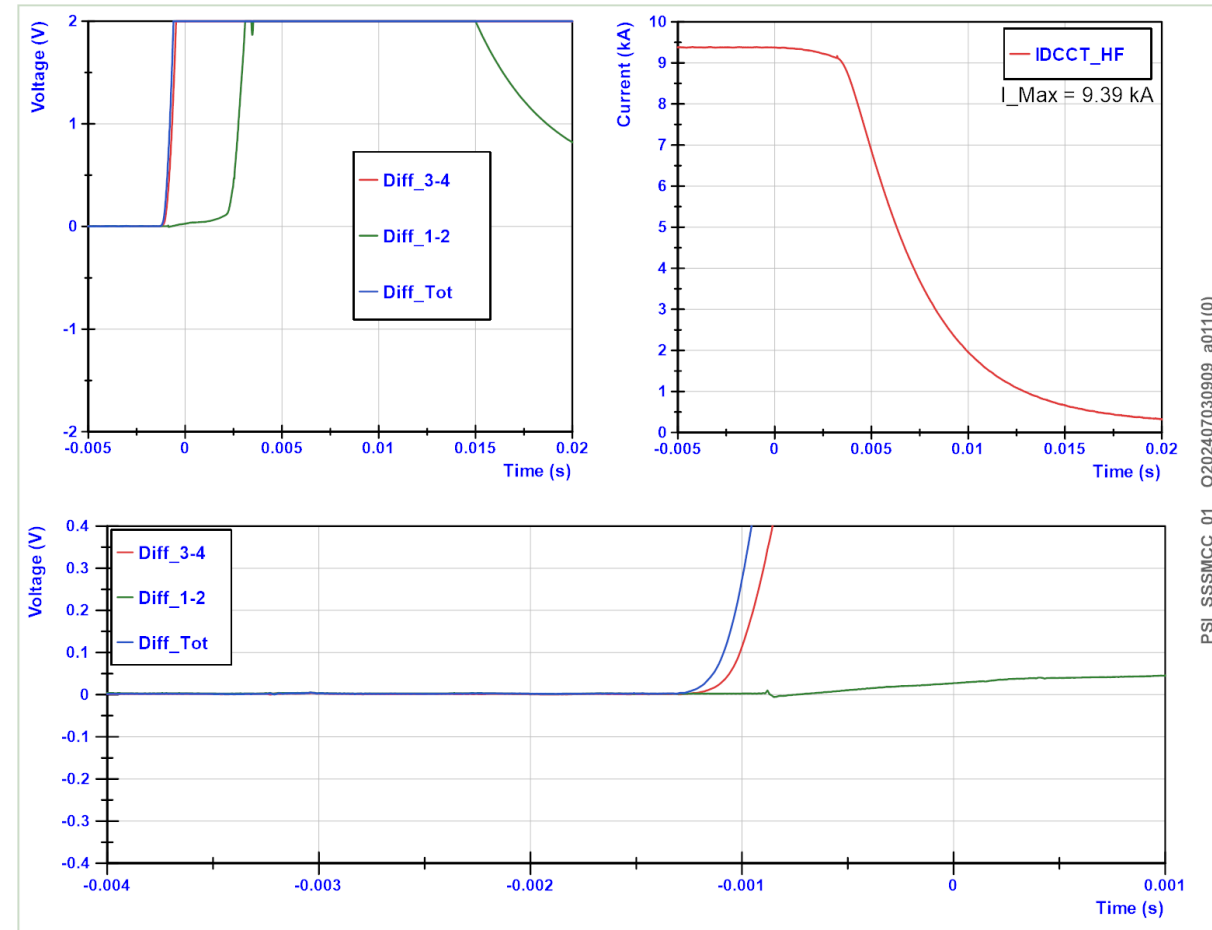
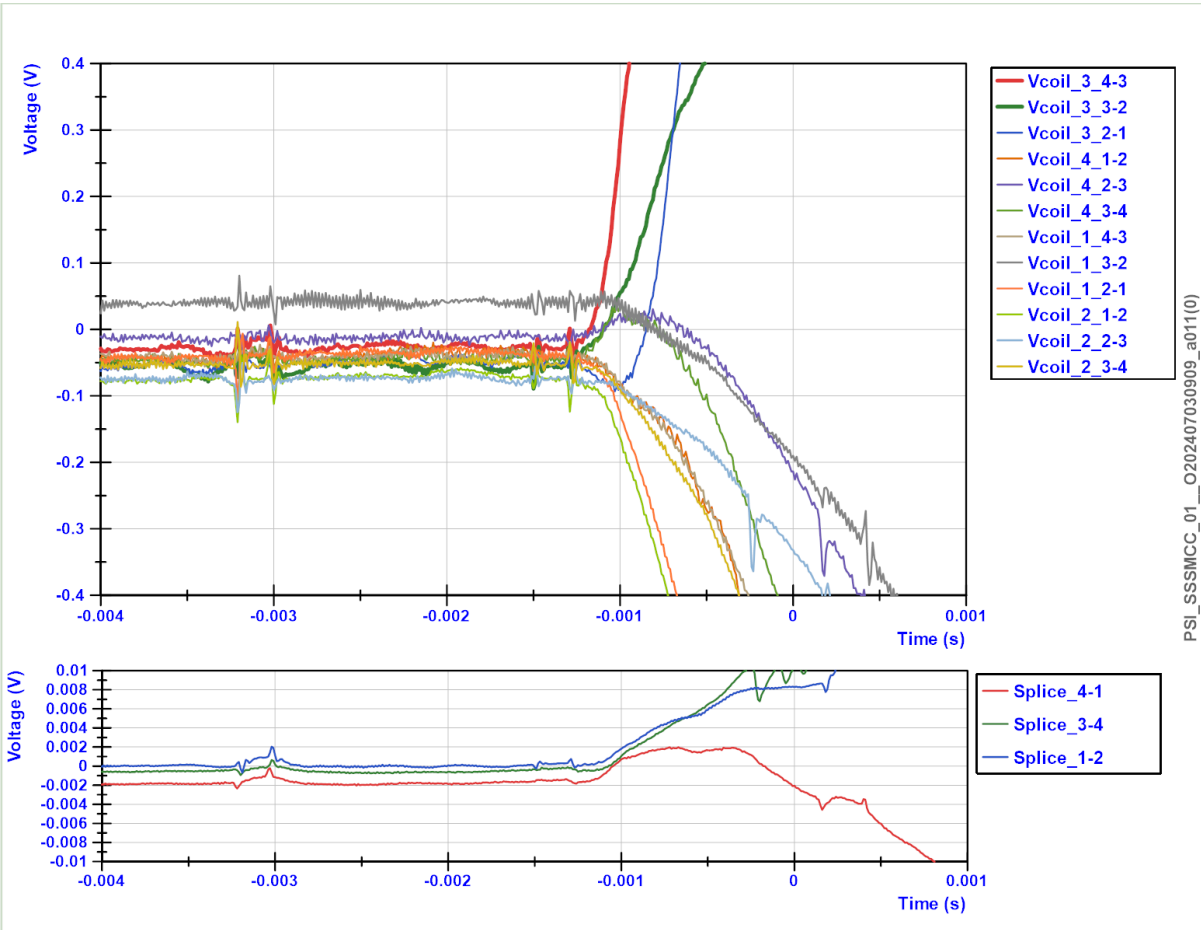

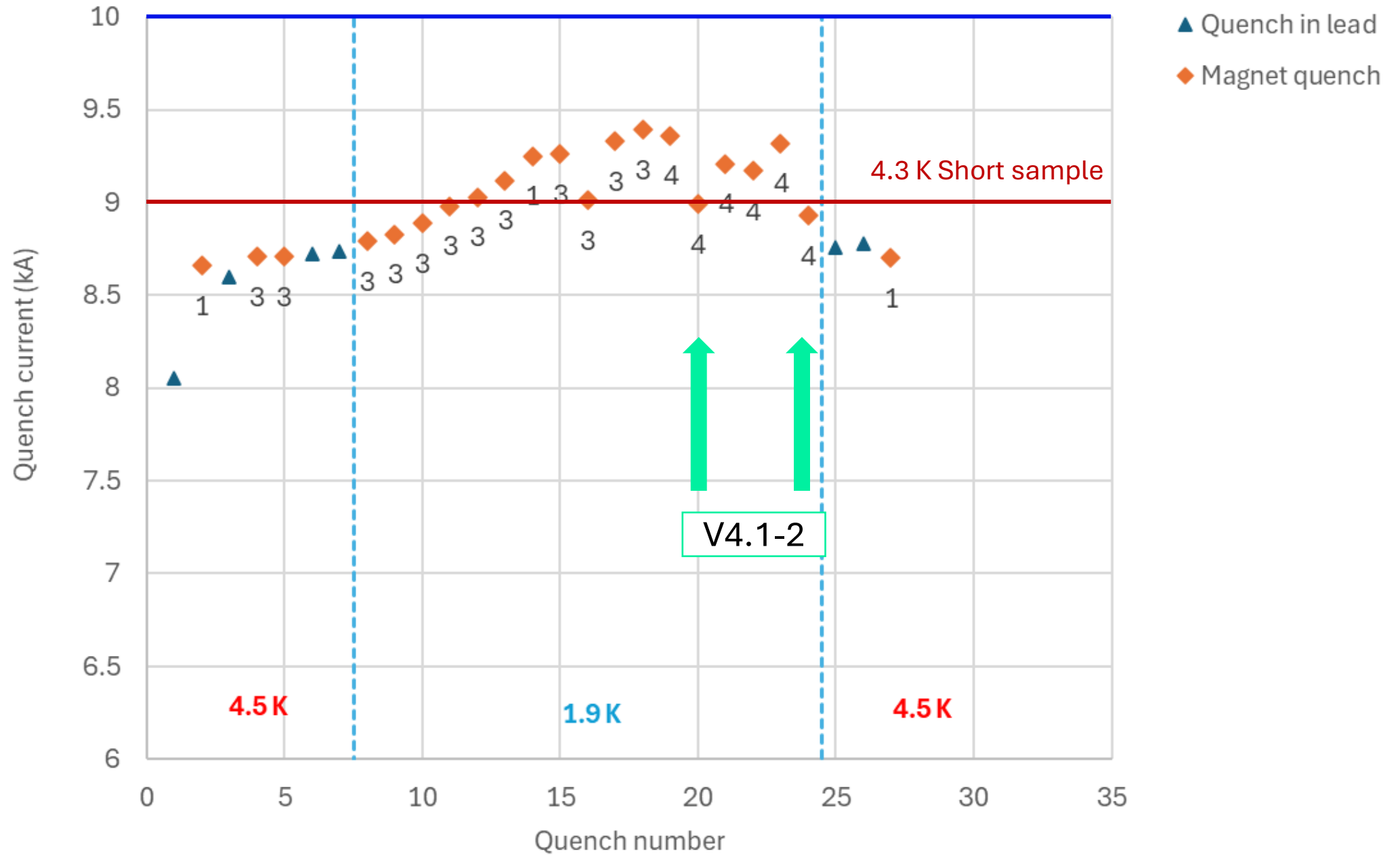

Event 24: 1st CD - 1.9 K – I_{max} = 8.99 kA | Coil 4



HFM
High Field Magnets
Programme

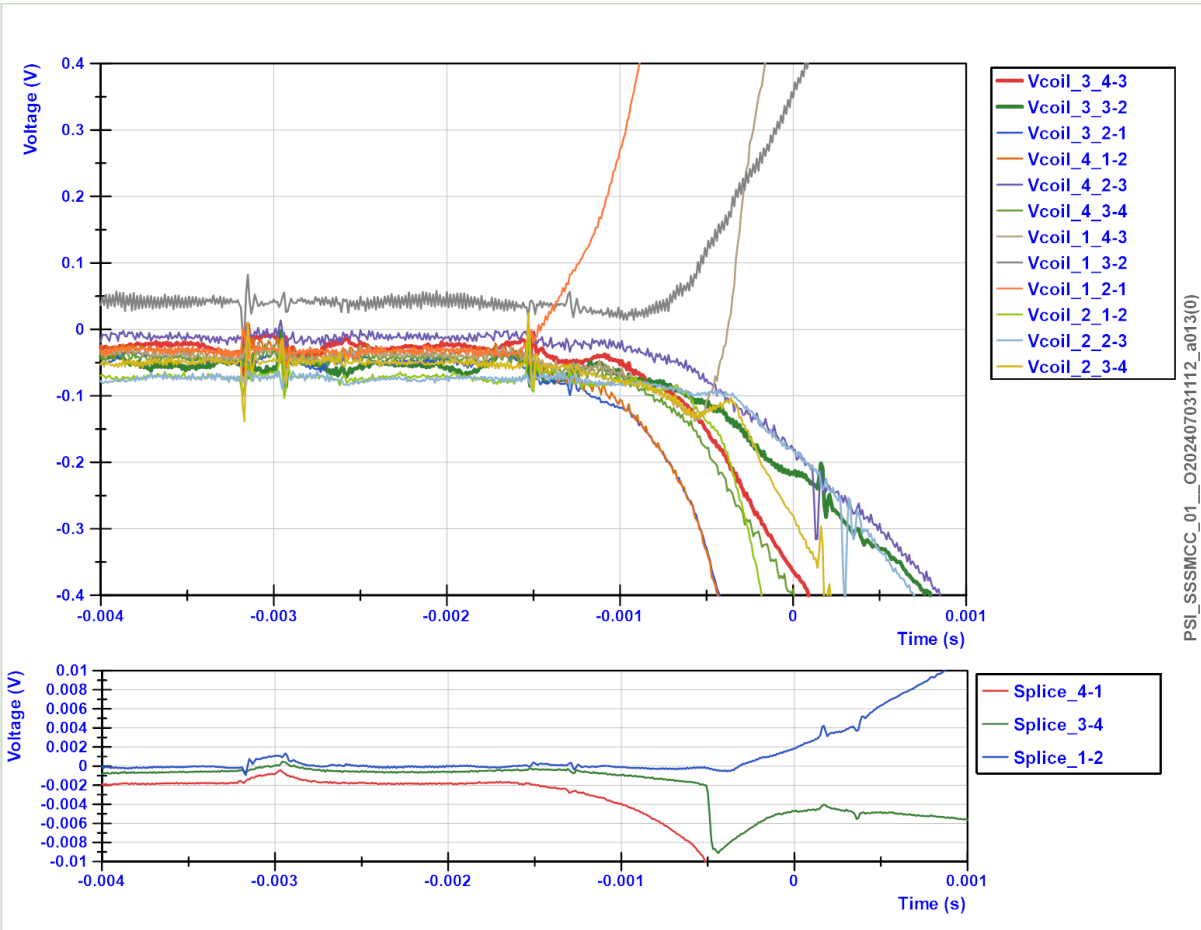

PSI_SSSMCC_01_O202407031112_a013(0)

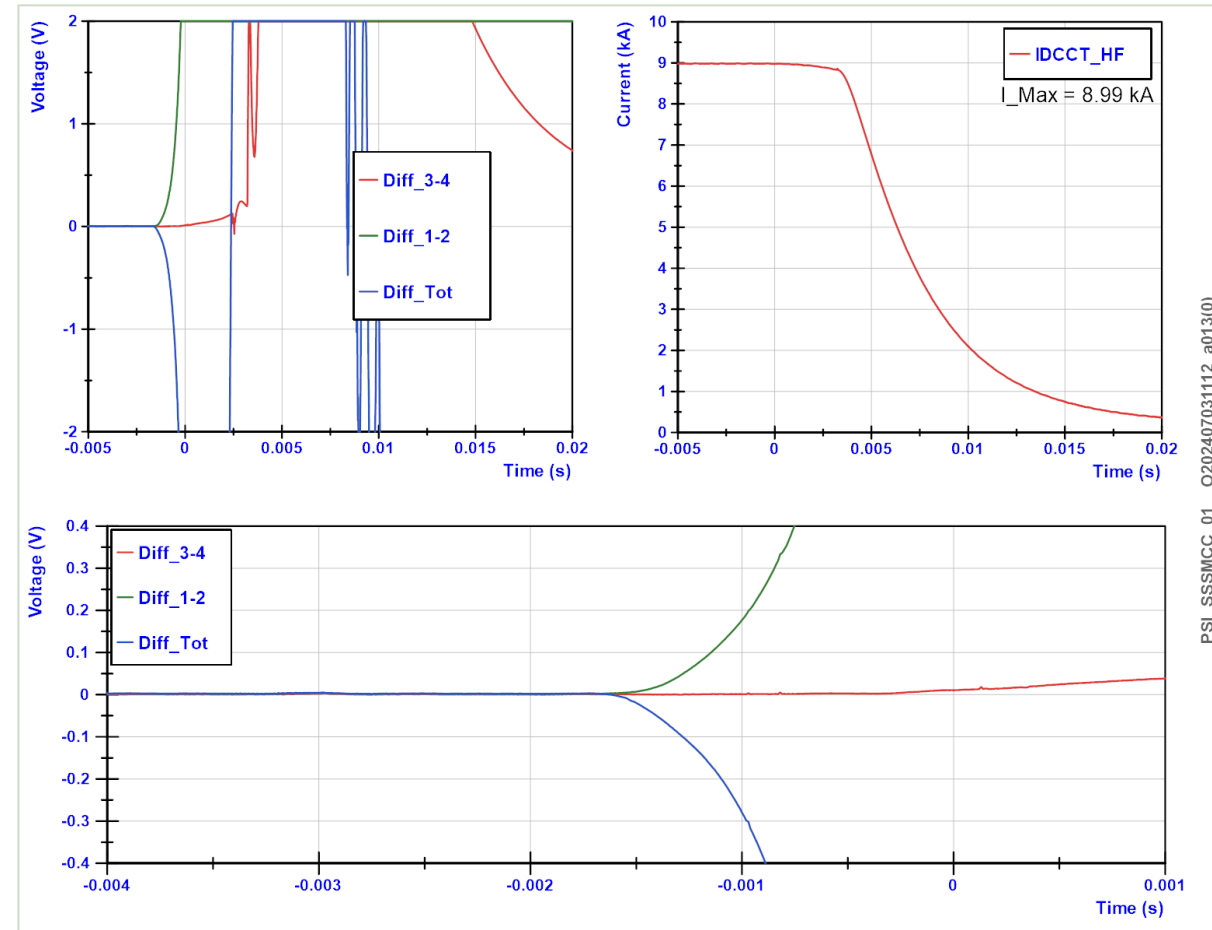

PSI_SSSMCC_01_O202407031112_a013(0)

I_{event18} – 400 A

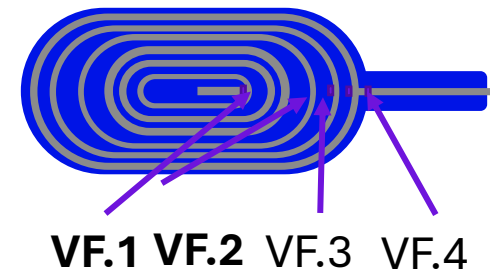

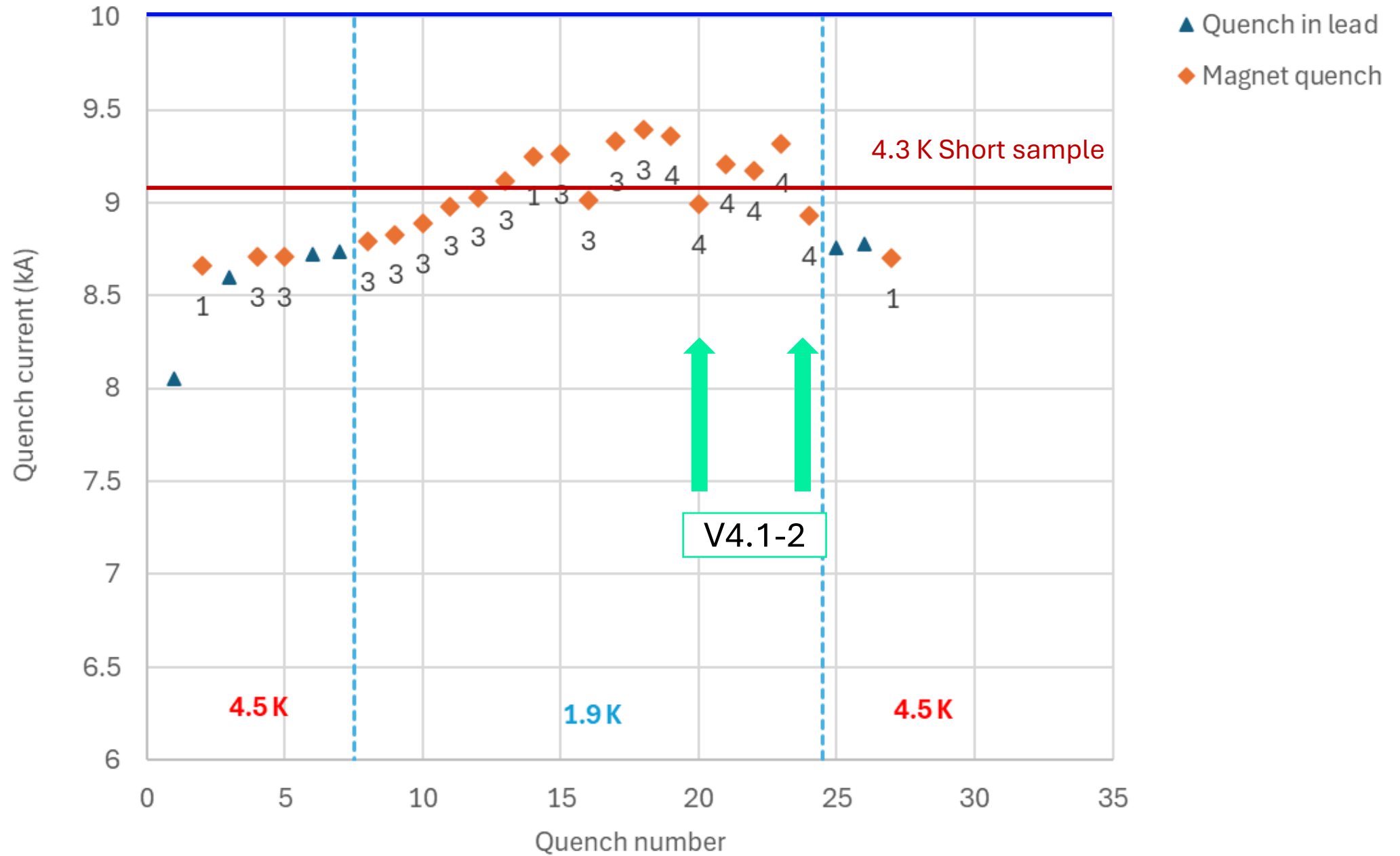

Event 24: 1st CD - 1.9 K – I_{max} = 8.99 kA | Coil 4



HFM
High Field Magnets
Programme

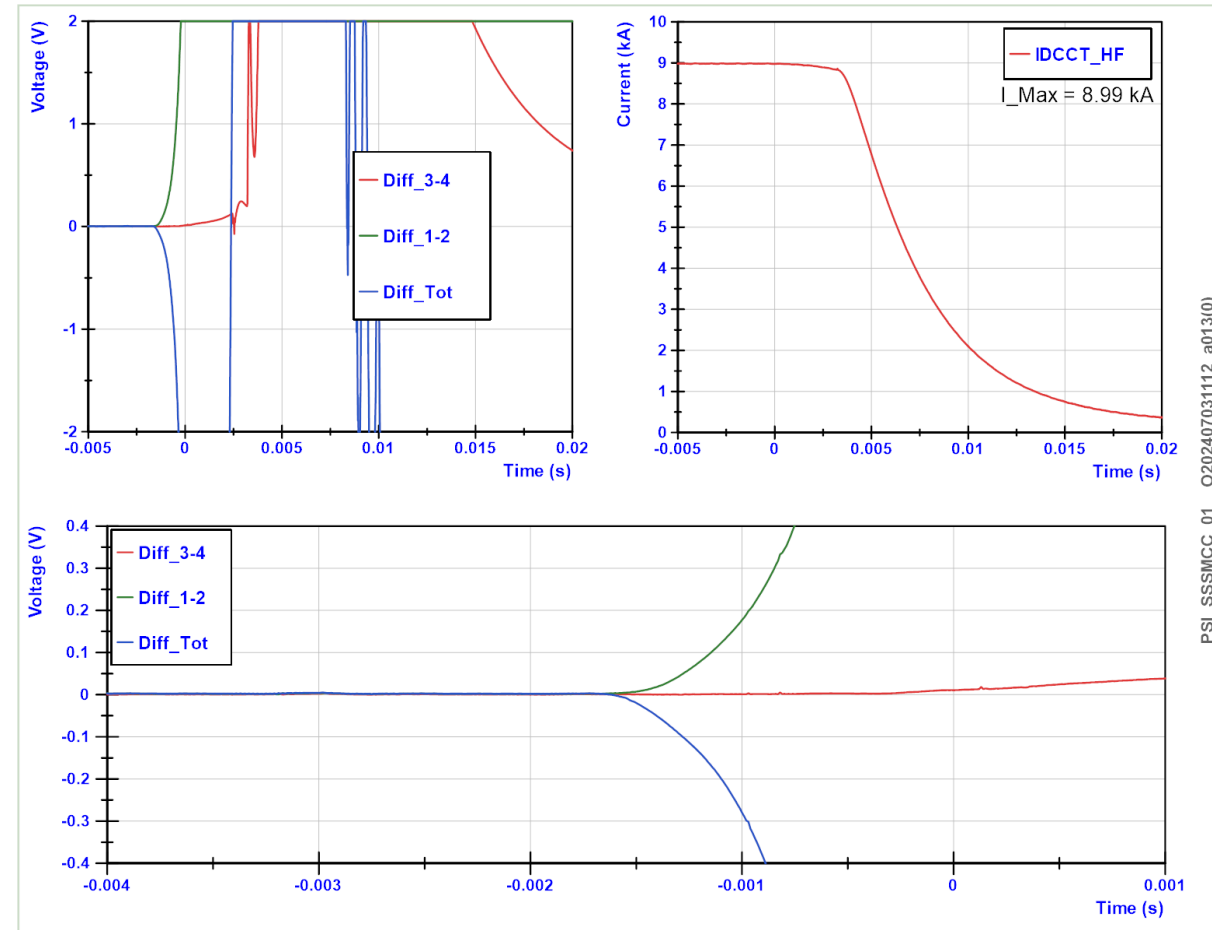
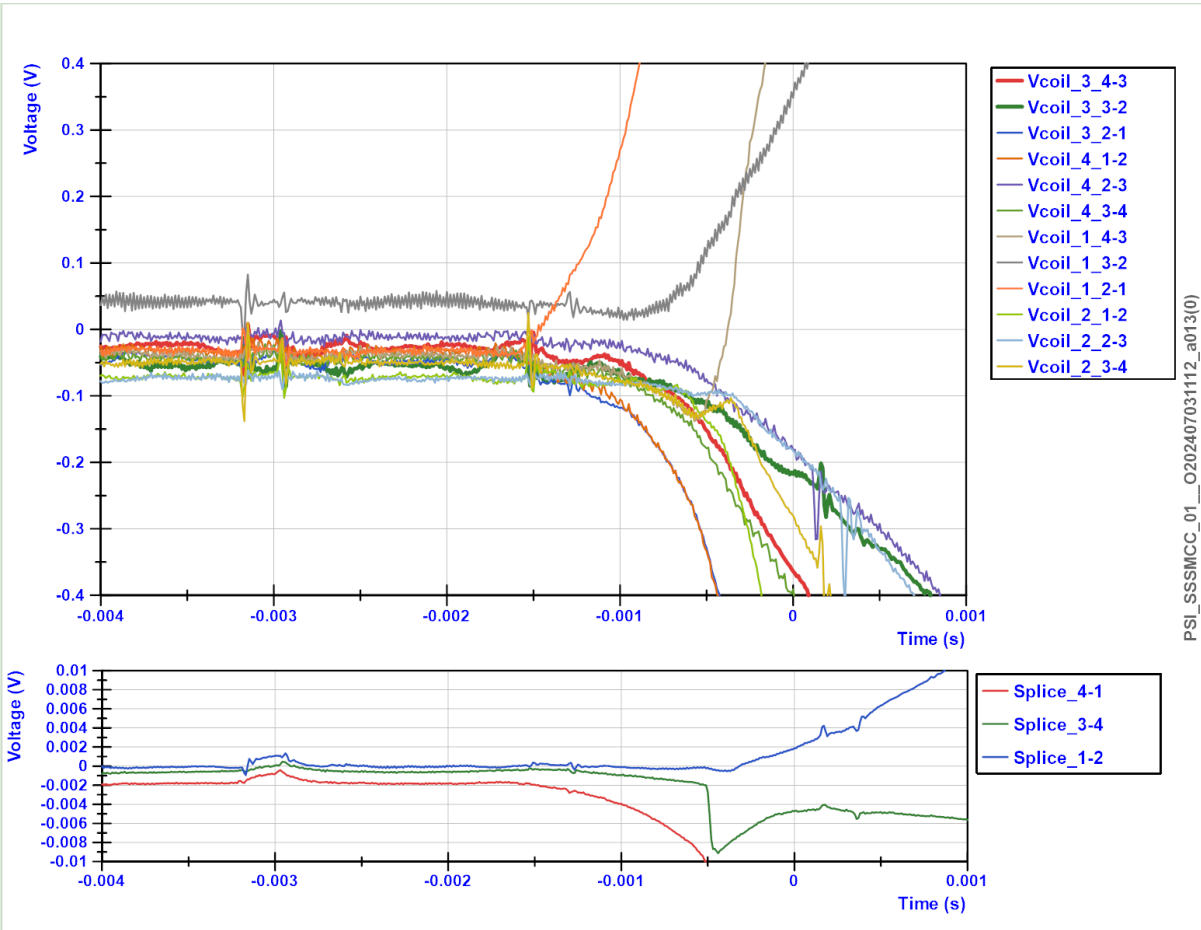

I_{event18} – 400 A (4.3%)

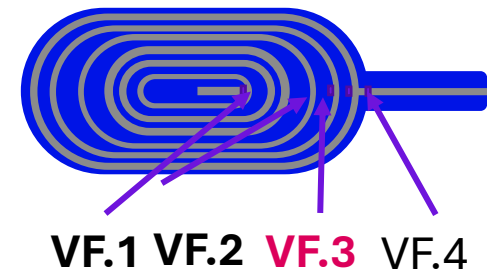

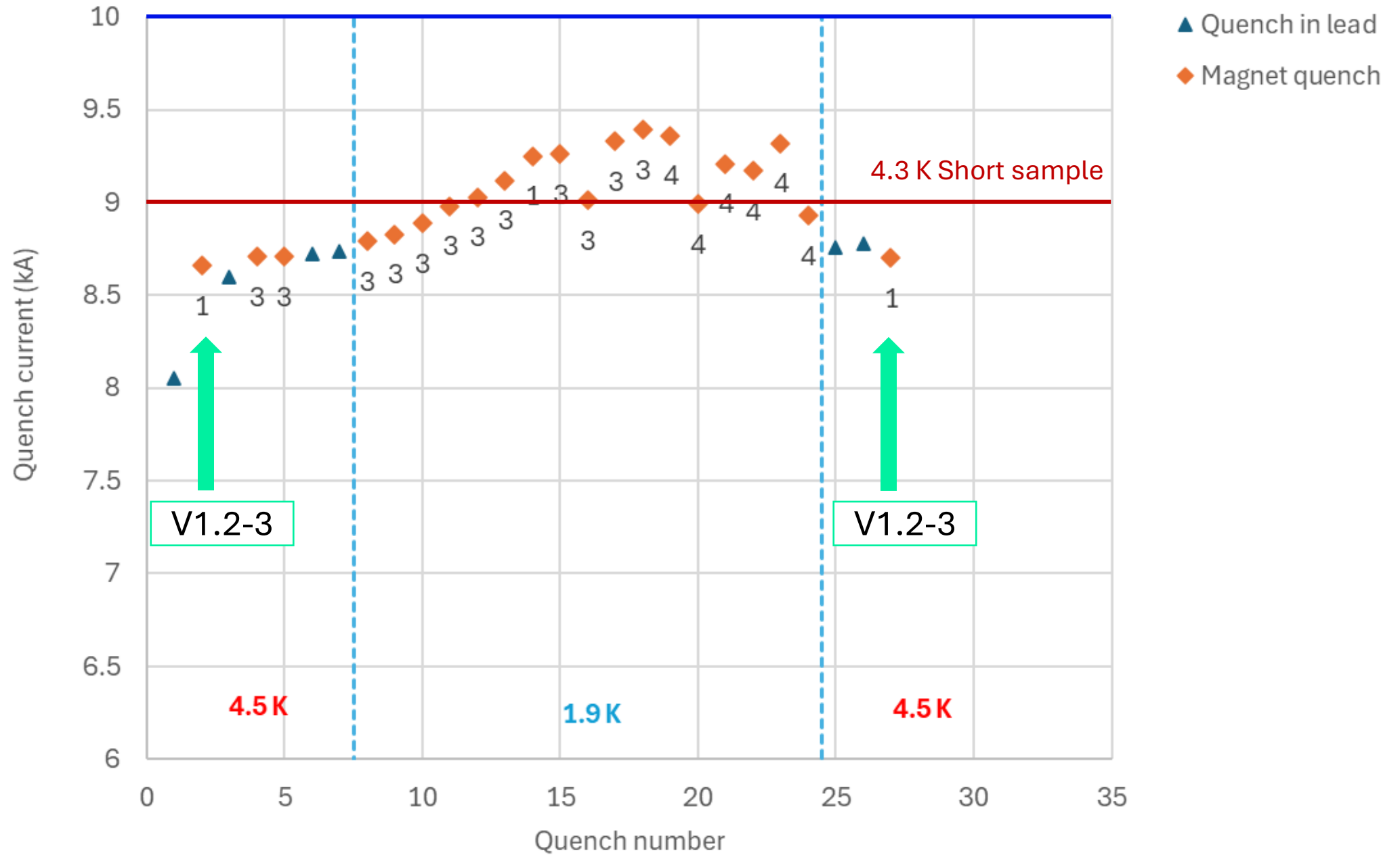

Event 27: 1st CD - 1.9 K – I_{max} = 8.7 kA | Coil 1



HFM
High Field Magnets
Programme



PSI

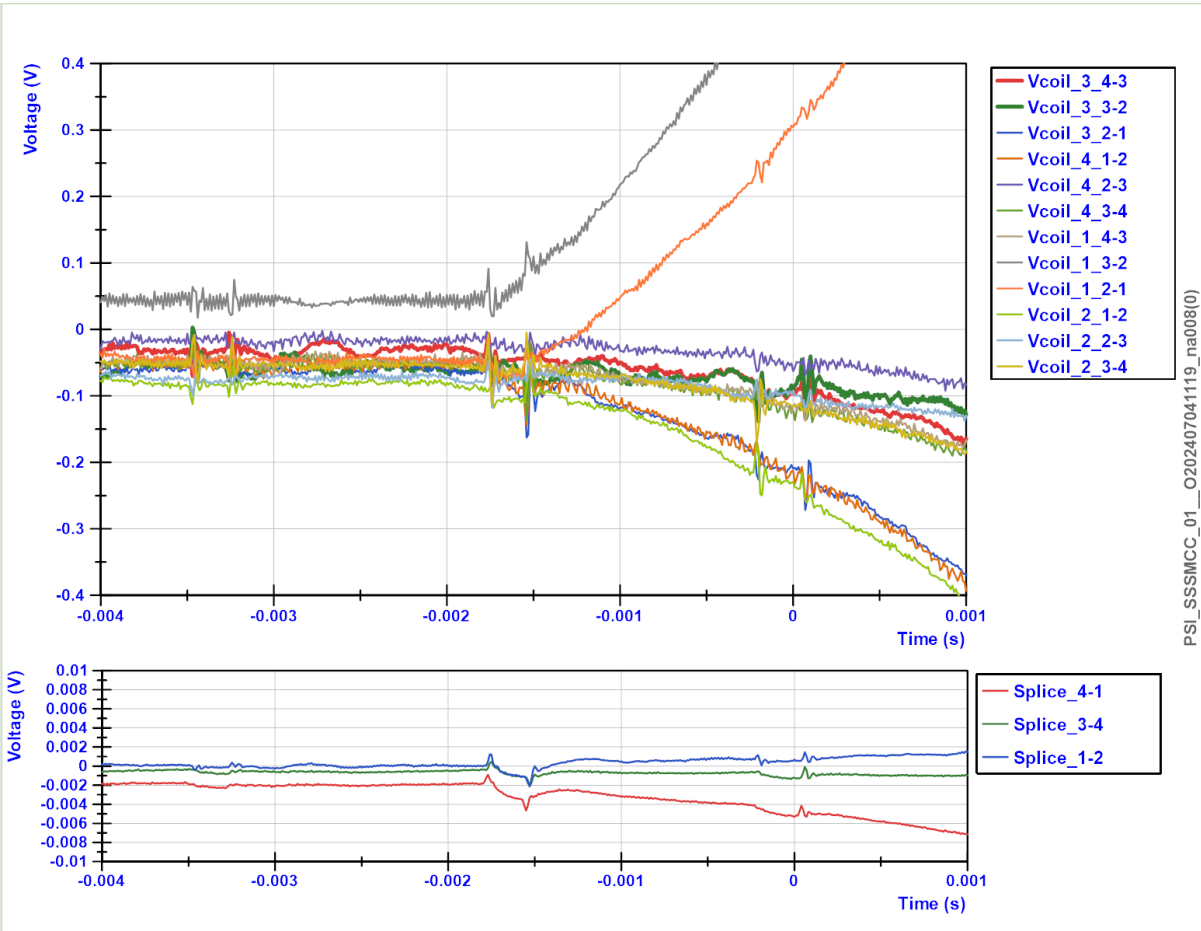

PSI_SSSMCC_01_O202407041119_na008(0)

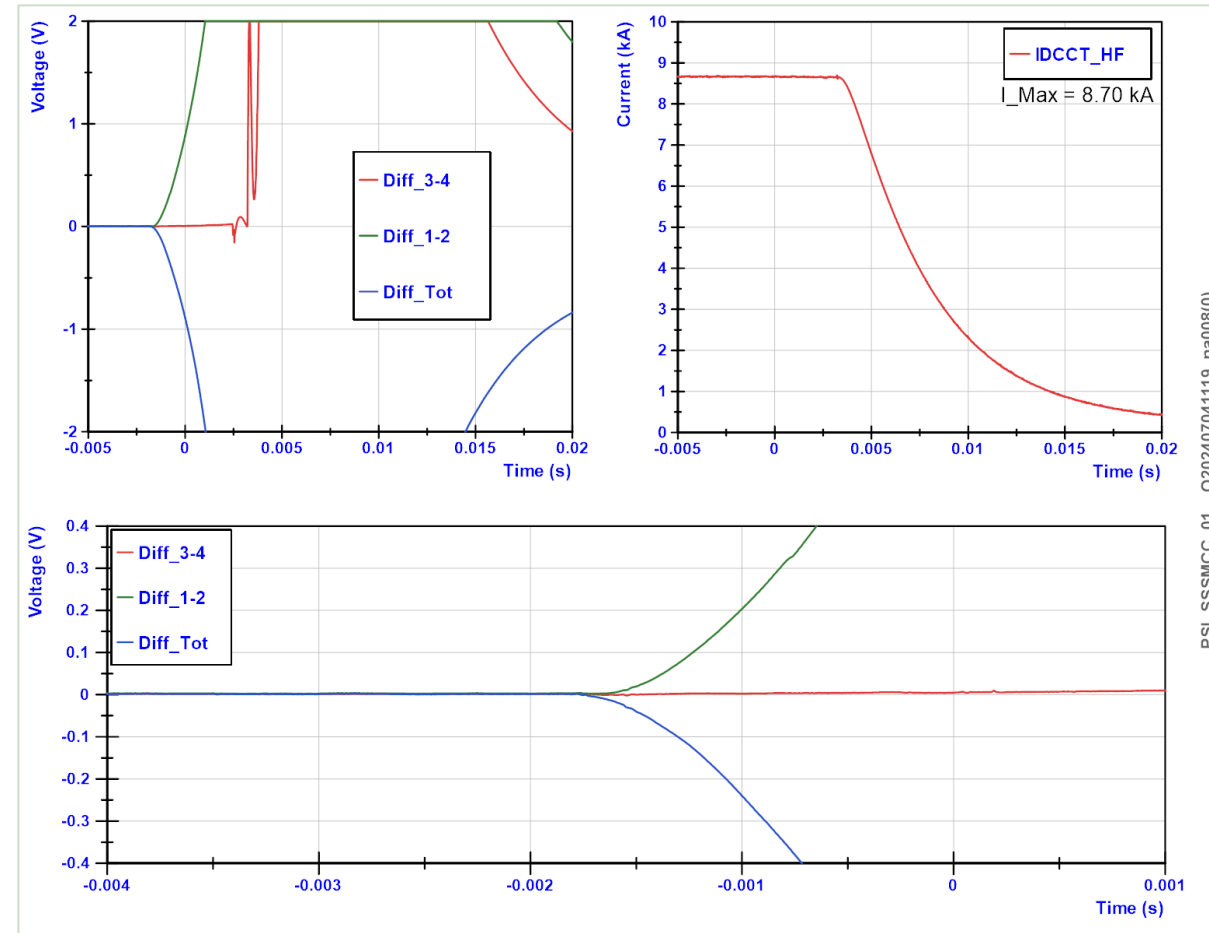

PSI_SSSMCC_01_O202407041119_na008(0)

$I_{\text{event2}} = 8.66 \text{ kA}$

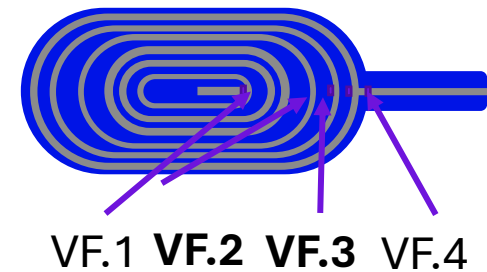

Impedance measurements



Measurement: One-Port

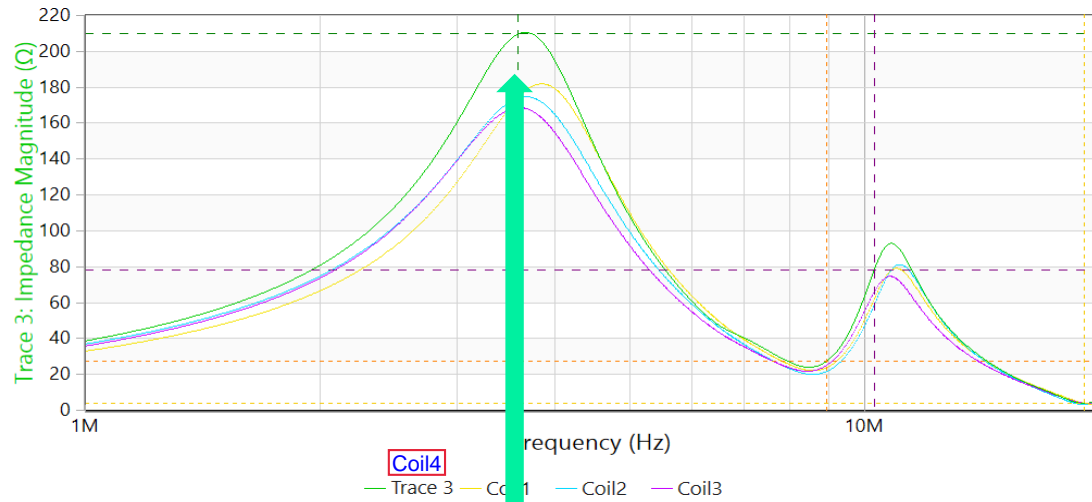

Coil 4 deviates from
de others

Measurement: One-Port

