



Hi-Lumi LHC Superconducting Link (DSL) Modifications

J. McAnerney, A. Lees

XX/XX/2024



LHC DSL Current Electrical Schematic

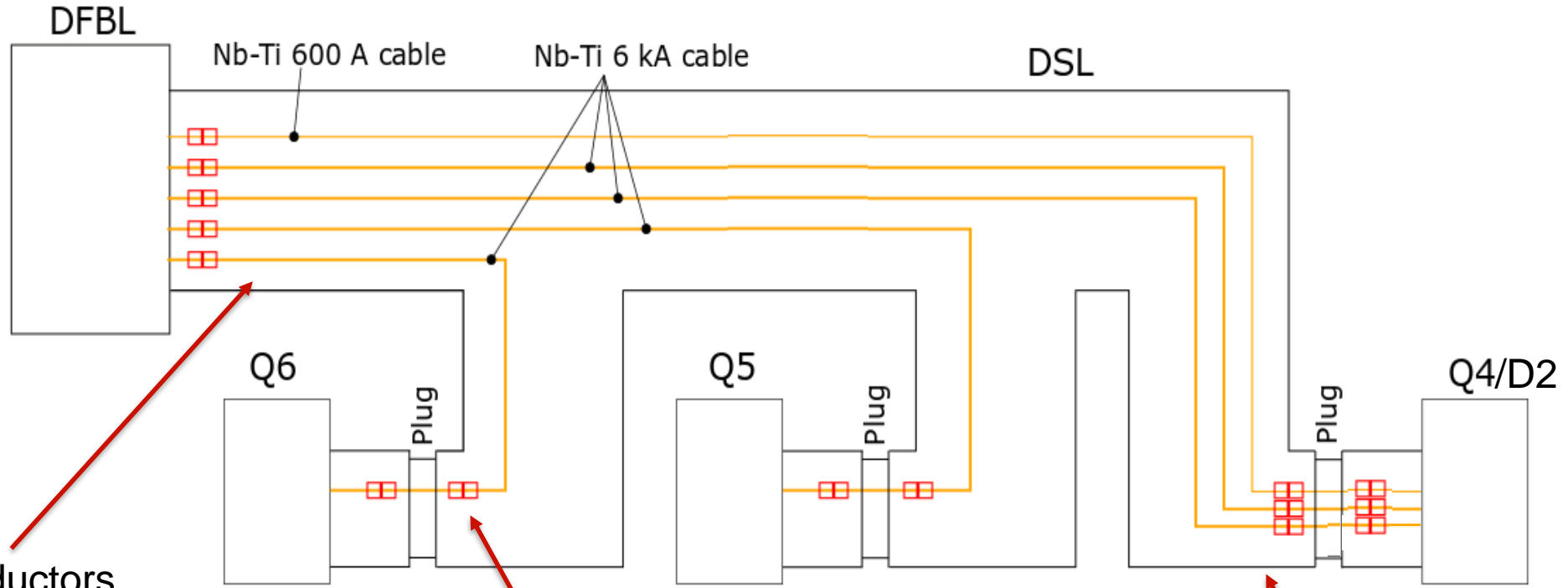

Custom conductors
No spares



Connection Box

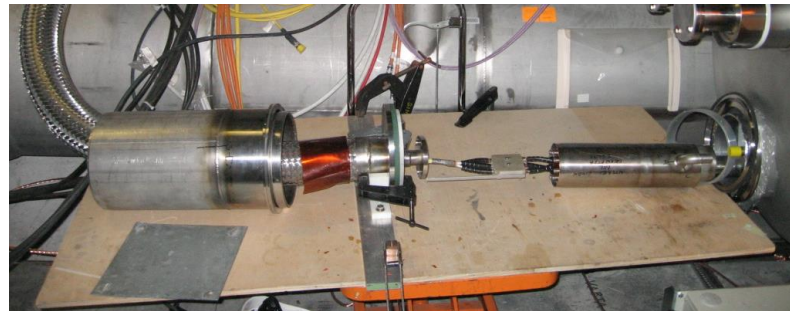

Q4 connection box

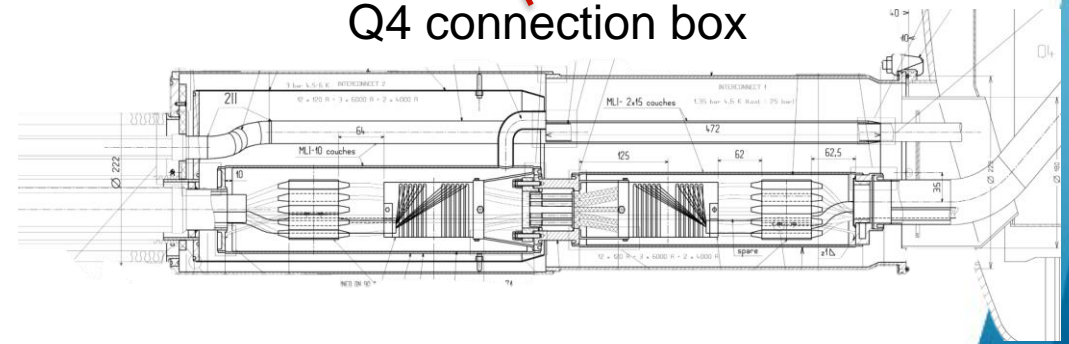

LHC Superconducting Link (DSL) Modifications

- DSL provides electrical current to the Q6, Q5 and Q4/D2 magnet.
- Q5-Q4 section to be translated by 10.5m toward Q6.
- The D2 supply will no longer required.

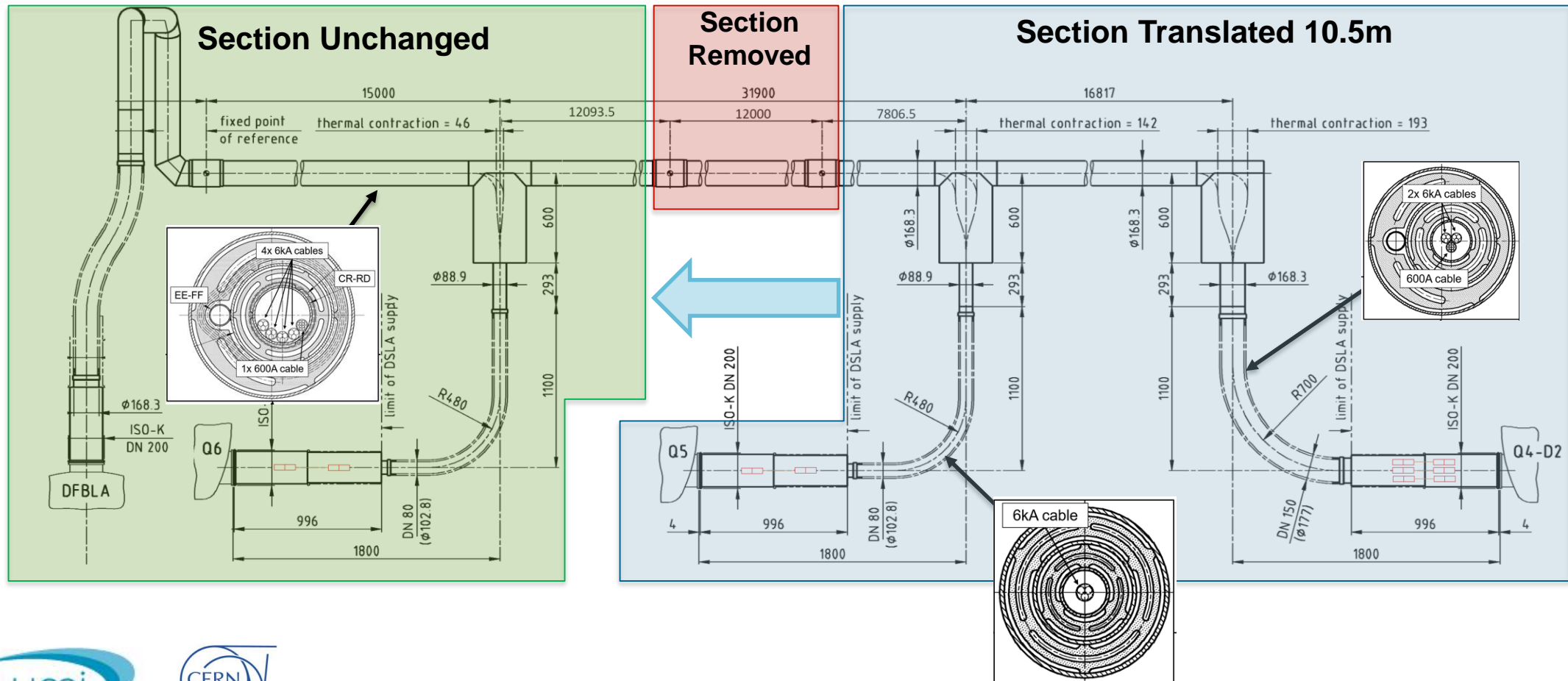

HL-LHC DSL Baseline: Electrical

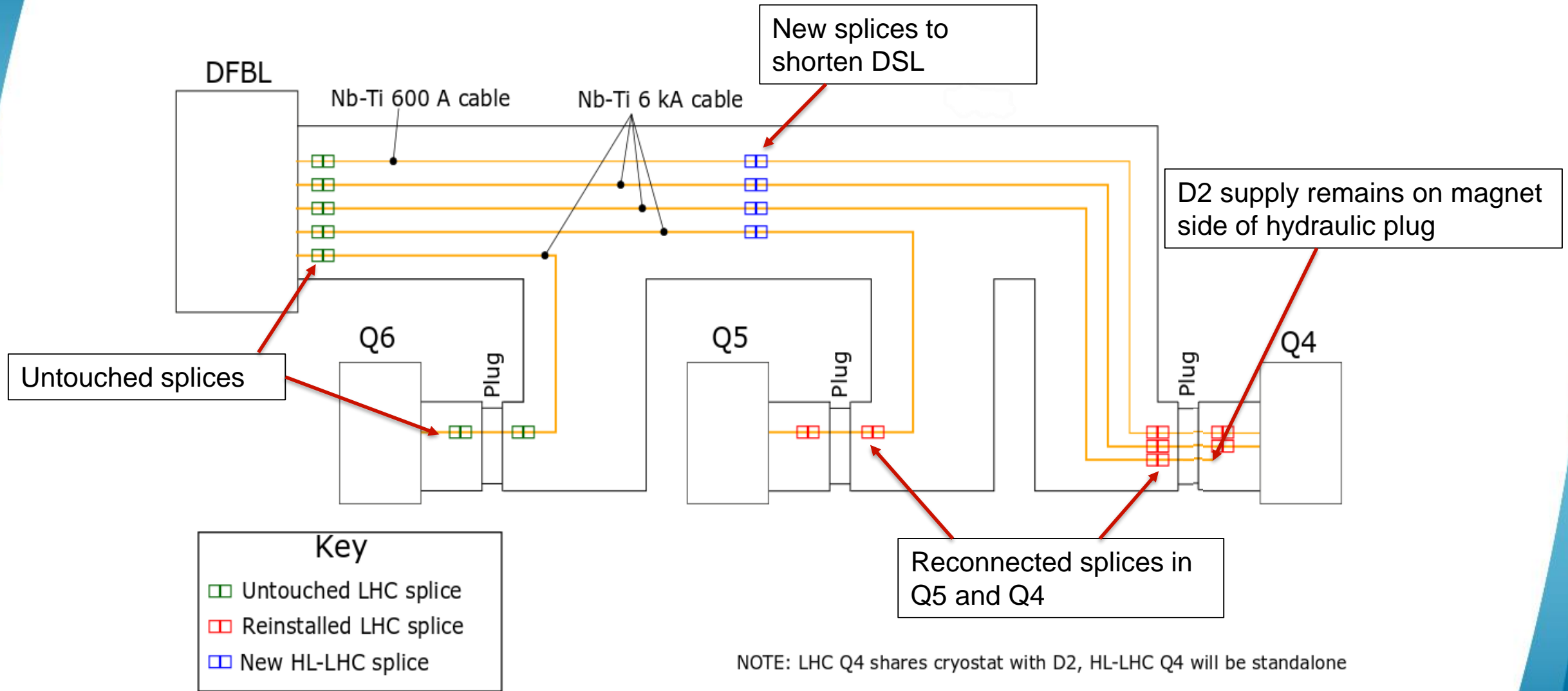

HL-LHC DSL Baseline: Mechanical

- 12.3m section of DSL removed
- DSL translated 10.5m toward Q6.
- Connection box of 1.82m installed, design requires further study.
- D2 supply remains as spare supply in DSL.

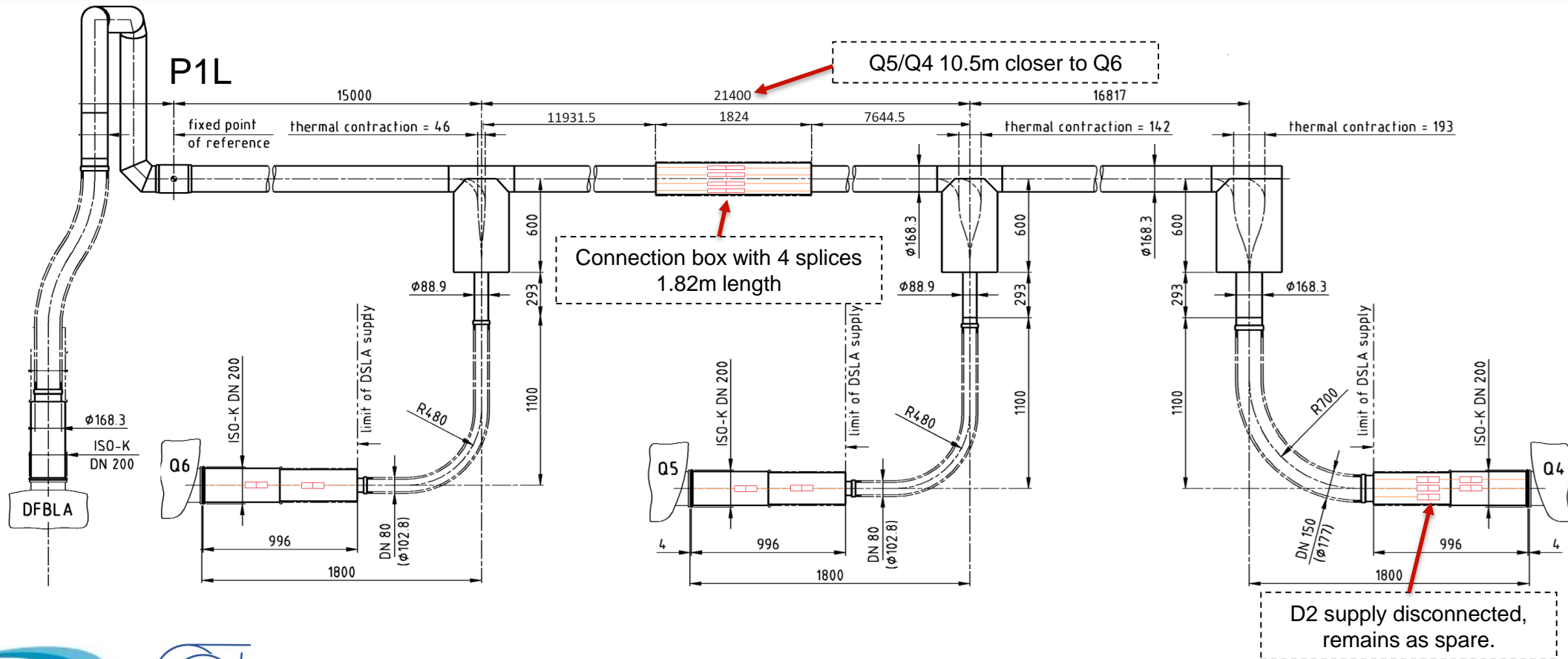

Baseline DSL Sections to Translate

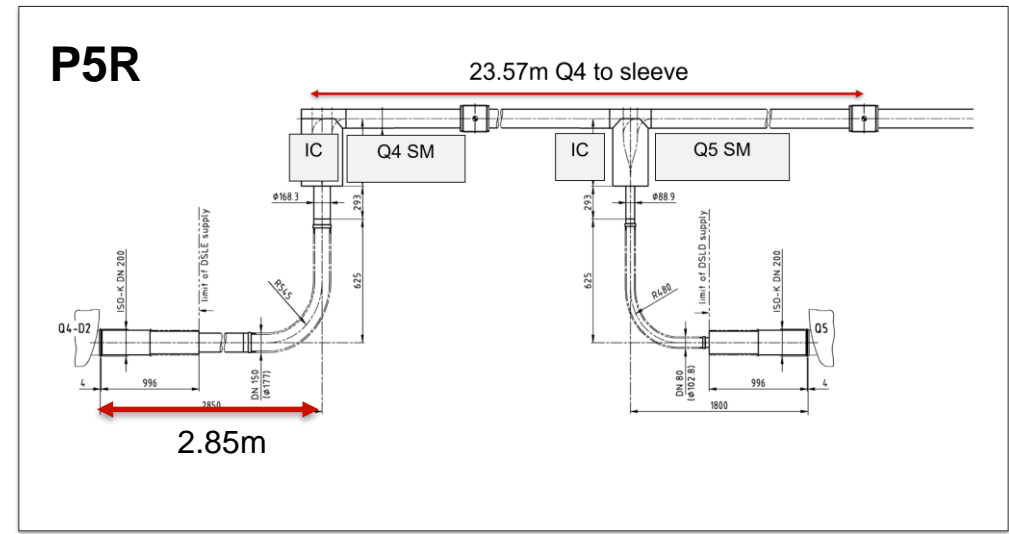
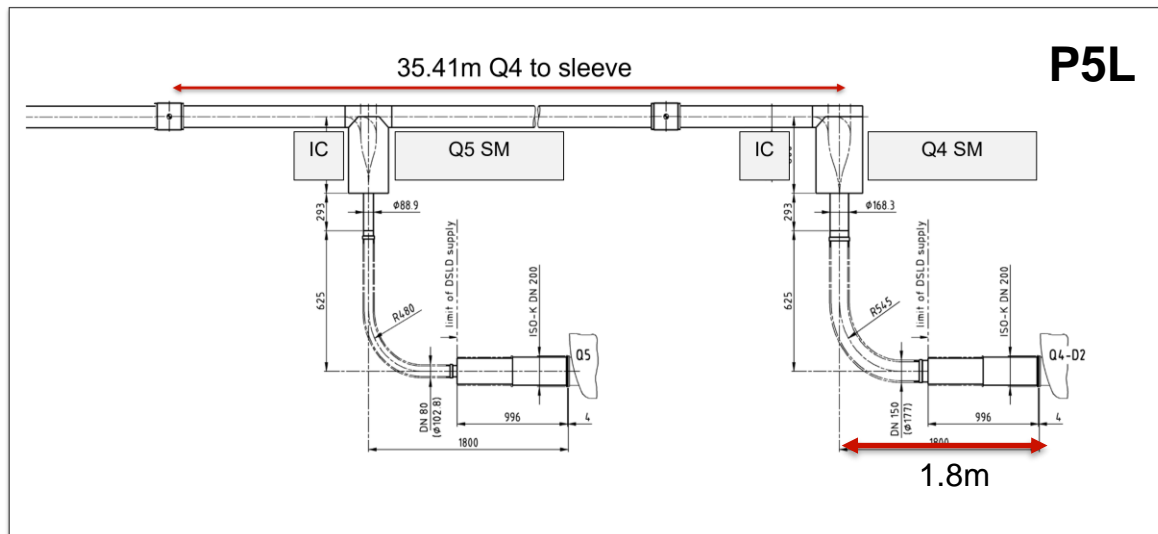
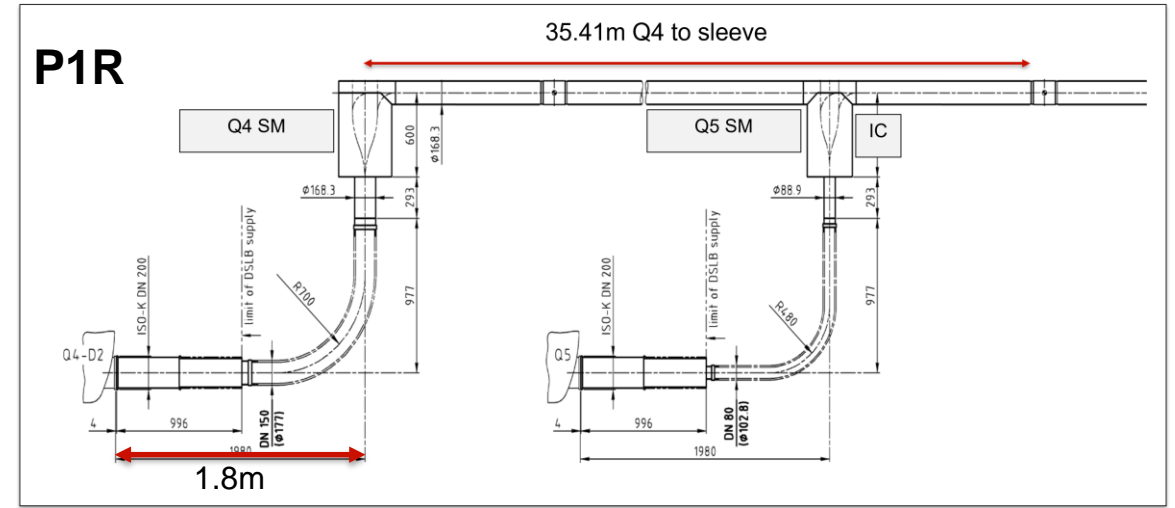
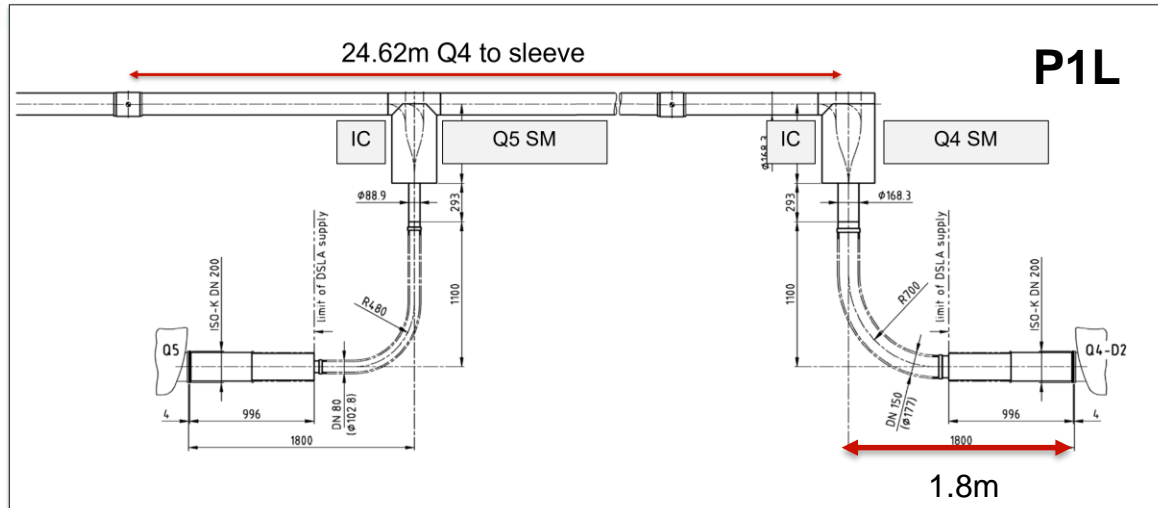

LS3 Civil Works

- Assumed complete removal of DSL up to Q6 during LS3 civil works.
- Removing DSL from tunnel in single piece is not possible.
 - DSL is fragile due to cryogenic components and superconducting cable.
 - Transport of sections is difficult due to length and flexibility.

Sector	Length to be moved (m)	Total Mass (kg)
P1R (S12)	35.41m	1110.9
P1L (S81)	24.62m	803.1
P5L (S45)	35.41m	1100.3
P5R (S56)	23.57m	778.2

- Alternative solutions to removing DSL studied:
 - Cutting into sections to remove from tunnel → Not preferred to reduce number of splices.
 - Storing DSL underground.
 - Leaving DSL in place in the LHC tunnel.

Cutting DSL into Sections

- 10 cm overlap of conductor required to complete splices.
- First cut takes 10cm overlap from removed section of DSL.
- For additional cuts there is no excess length available, splice cannot be completed without either:
 - Cables need to be pulled risking damage to conductor.
 - Use 50 cm or longer piece of conductor recovered from cut removed section of DSL. This requires two splices.
- Each subsequent cut of DSL will add further two splices to the system.

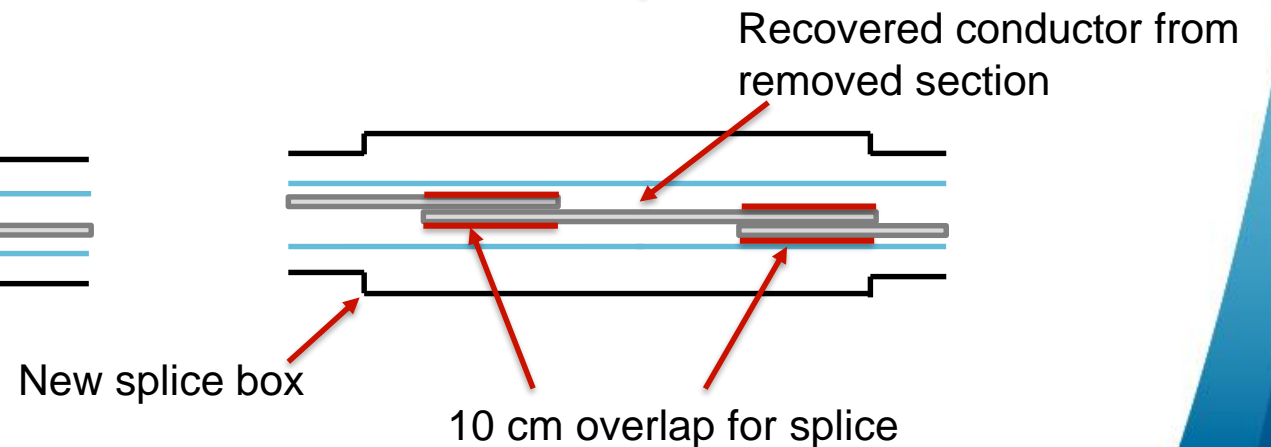
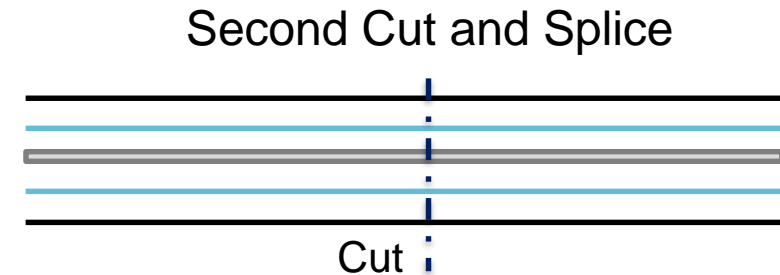
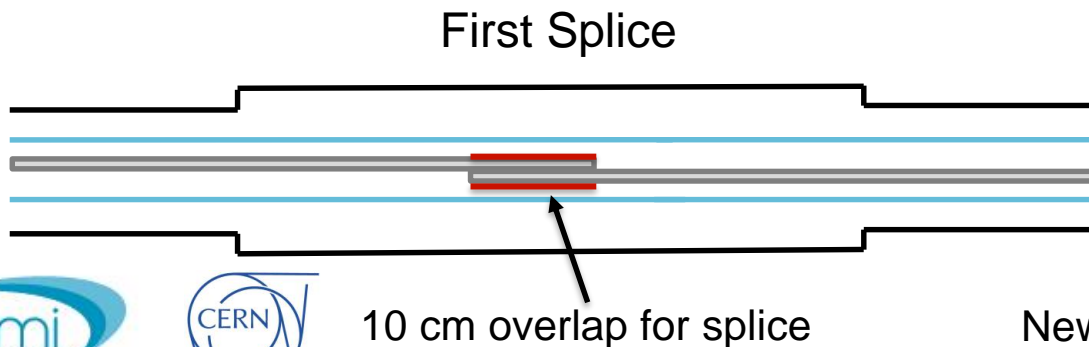
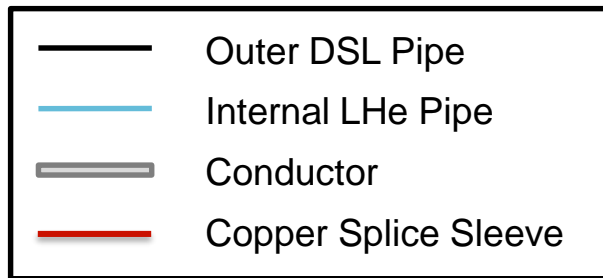

Storing DSL Underground

- Storage location underground
 - UJ88 identified for DSL in P1L (S81).
 - Very complex to transport DSL in other sections to UJ88. DSL can't pass experiments in current configuration.
 - Maximum length is 16m that can be transported > 35m section needs to be cut into 3 pieces.
 - No other area found in for DSL in other LSS.
- Storing above dipoles for other sectors.
 - Avoiding areas where beam screens to be replaced.
 - Avoiding Q10 which is being removed.
 - Avoid areas where magnets will be replaced.
 - Avoid interference with magnet alignment activities.
 - Custom tooling for transport and storage required.

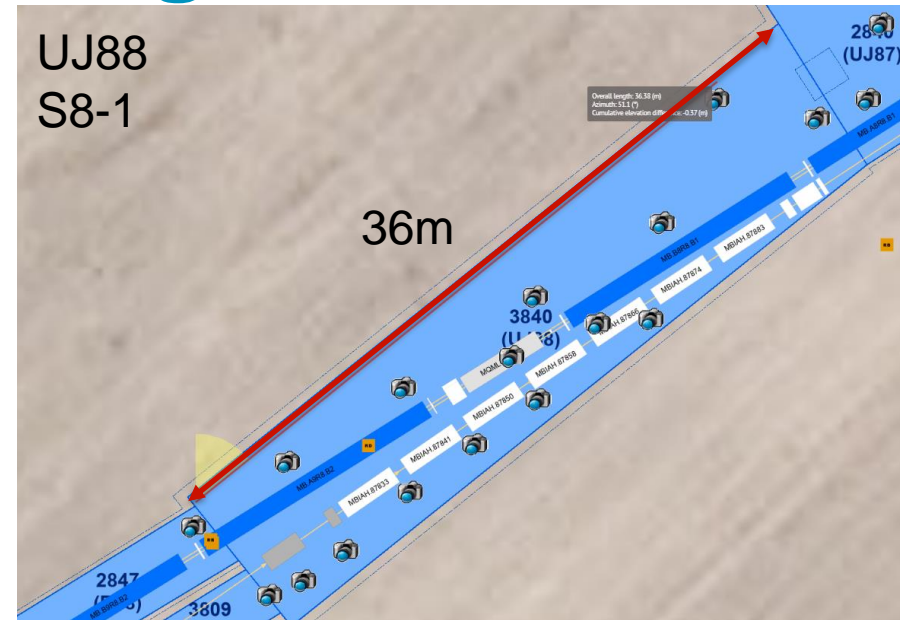

Storing DSL: Transport

- Current DSL installation has:
 - External support every 3.5m.
 - Internal spacer every 2.8m.
 - External support 1m each side of each branch.
- Custom lifting equipment required to move DSL.
 - Unsupported length should be less than approximately 5m to avoid excessive deflection.
 - Load should be distributed equally on all supports through all operations.
 - Constrain flexibles to maintain current shape of conductor.

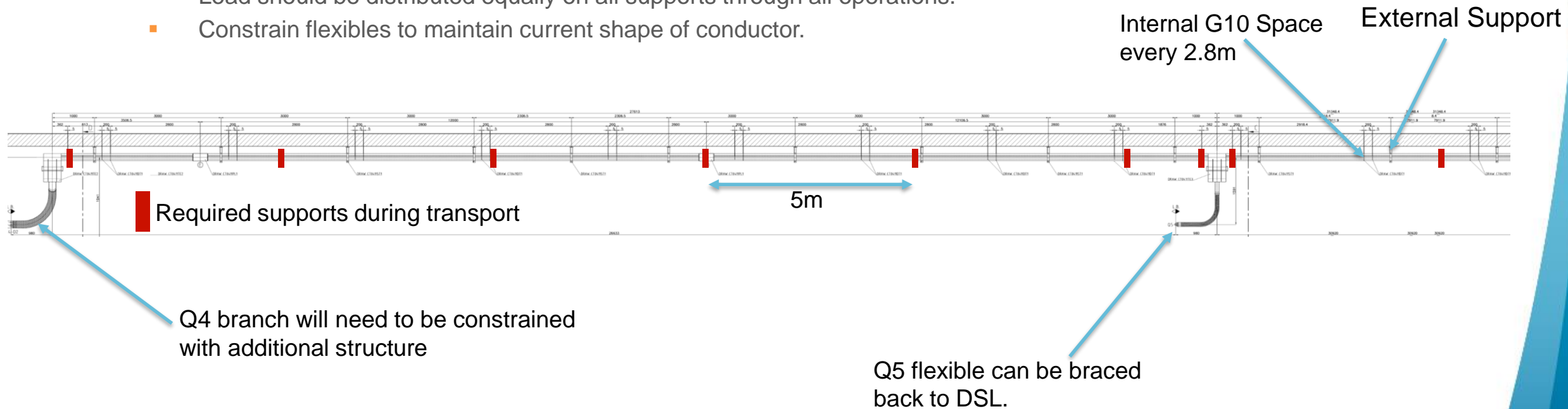

Leaving DSL in Place: Civil Works

- Distance from cores to current Q4 DSL connection is 7.5m → Distance increases to 18m in HL-LHC.
- At P5 trenches are being cut past the Q6.
- Location of SAS to be verified.

Images show HL-LHC

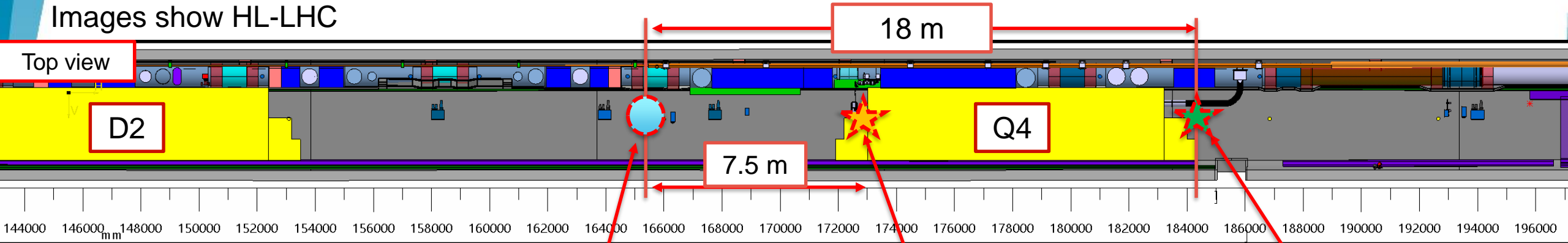

End of unchanged section of DSL

Core

Current Q4 DSL connection

HL-LHC Q4 DSL connection

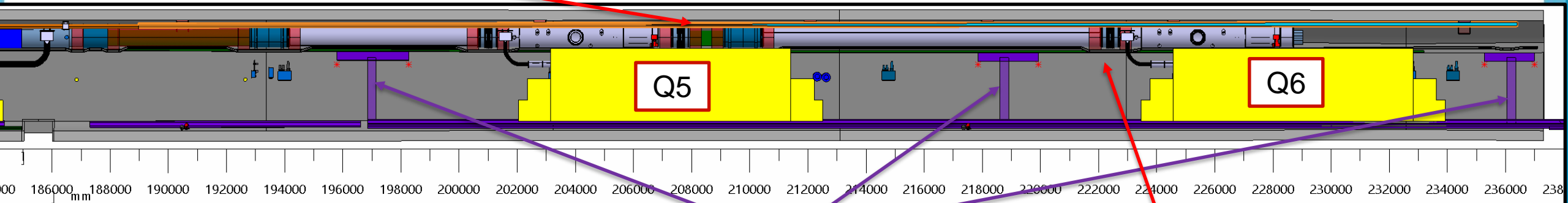
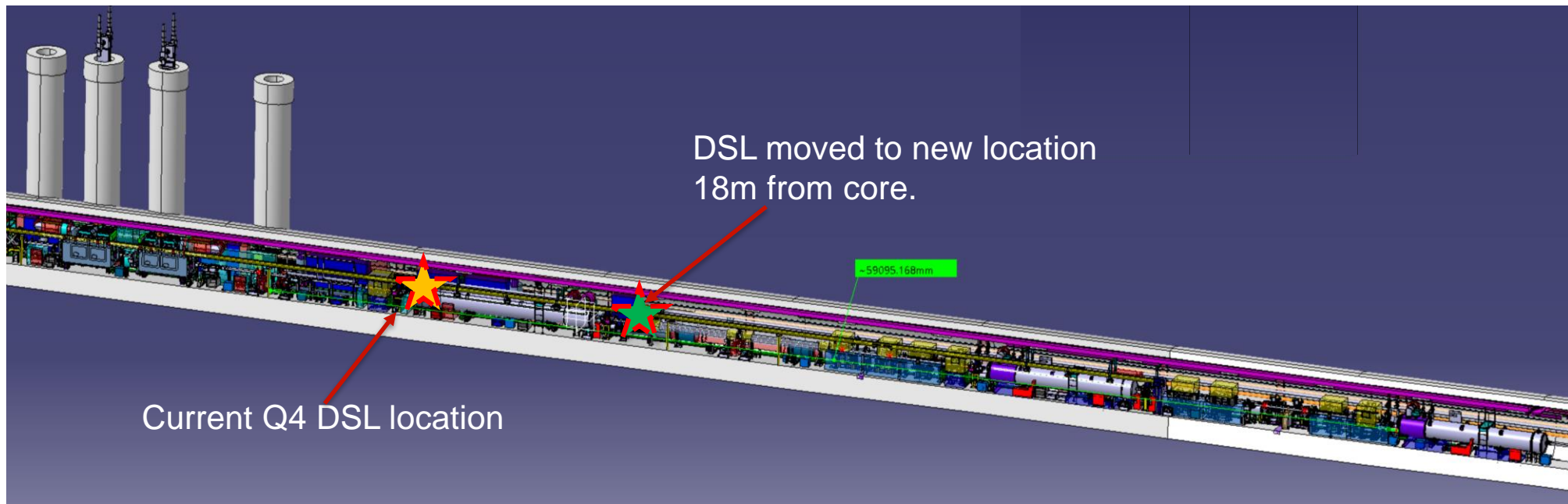

Image from Stephane Maribor

Storing DSL in Place

- Proposal to leave DSL in HL-LHC position in tunnel.
 - Only local translation requires – negates risk of long distance transport.
 - Reduces time and resource required to complete DSL intervention.
 - Protection during civil works is possible to achieve.
 - Reduced requirement for bespoke tooling.
 - Only single splice per DSL section required.



Conclusion

- DSL is critical component for LHC function with a bespoke conductor with no spares.
- Limited possibilities are available to store DSL underground.
- Transport of DSL resource intensive, requires bespoke equipment and represents additional risk to DSL integrity.
- CRG proposes to store DSL in HL-LHC position on tunnel wall and protect it from civil works.