

# MPGD production and R&D at the University of Virginia

Nilanga Liyanage and Huong Nguyen

University of Virginia

# Tracking needs for Jefferson Lab Hall A experiments

- **Some of the highest luminosity experiments ever: up to about  $5 \times 10^{38}$  ! With open spectrometers and direct line of sight to target**
  - Rates at the tracker approaching MHz/cm<sup>2</sup>
  - Need to cover large areas: 10s of m<sup>2</sup>
  - Need to tolerate high radiation doses.
  - require good spatial Resolution: ~0.1 mm
  - Lower energy particles compared to LHC: ~ few GeV: need low material thickness
  - Relatively small experiments with relatively small budgets: need a cost-effective solution: silicon is not cost effective in most cases
- GEM and other MPGDs are a natural choice.
- Jlab SuperBigbite Spectrometer GEM project: largest in the world in the pre-CMS GEM project days.
- Very lucky to get Kondo to lead this project.





# SBS GEM trackers

- 50 cm x 60 cm GEM modules for SBS rear tracker: 50 modules built: 48 modules operational – 40 have been in beam, 8 spares
- 150 cm x 40 cm large GEM modules for SBS front tracker: 6 modules built ; all 6 operational – all in beam

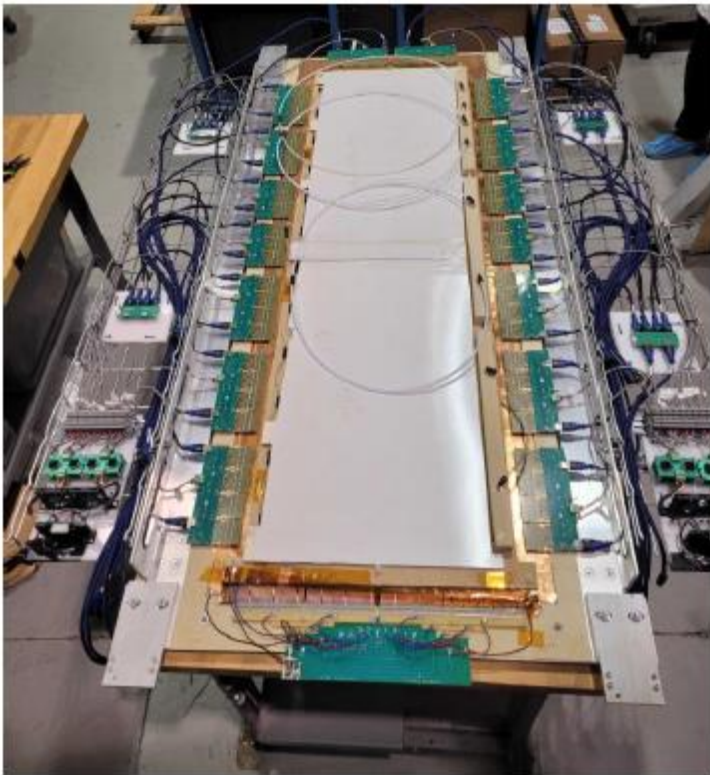

UV (shown)  
40 x 150 sq.cm  
Single module



XY (shown)  
60 x 200 sq.cm  
4 modules

# SBS Large GEM construction

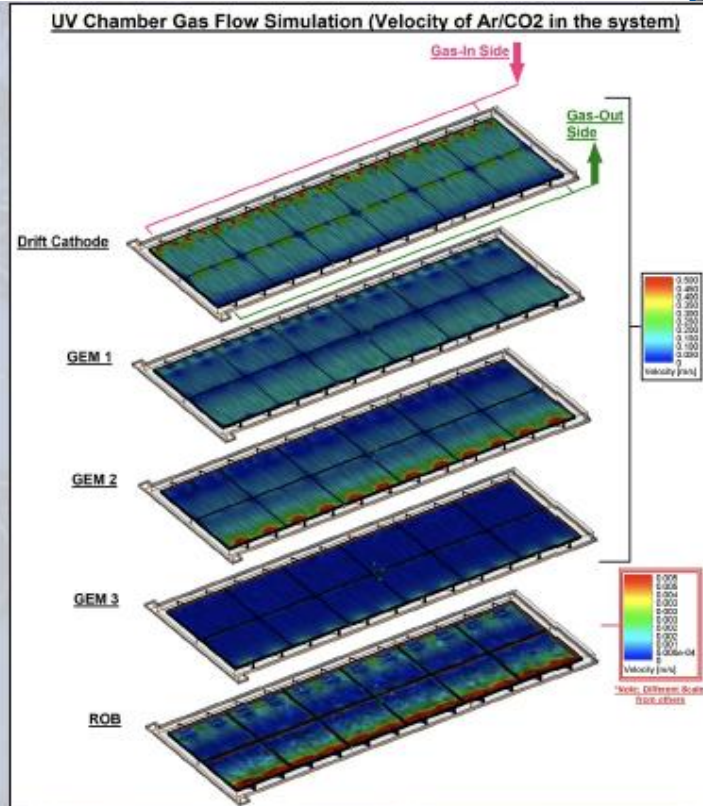
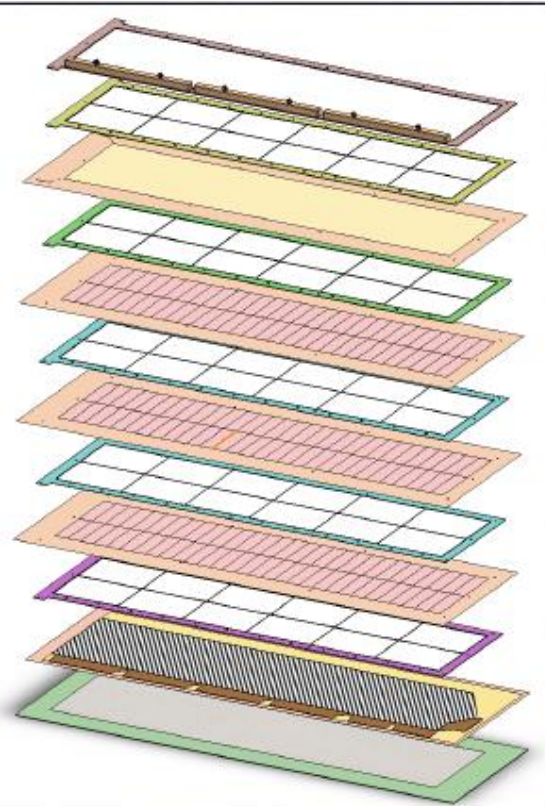
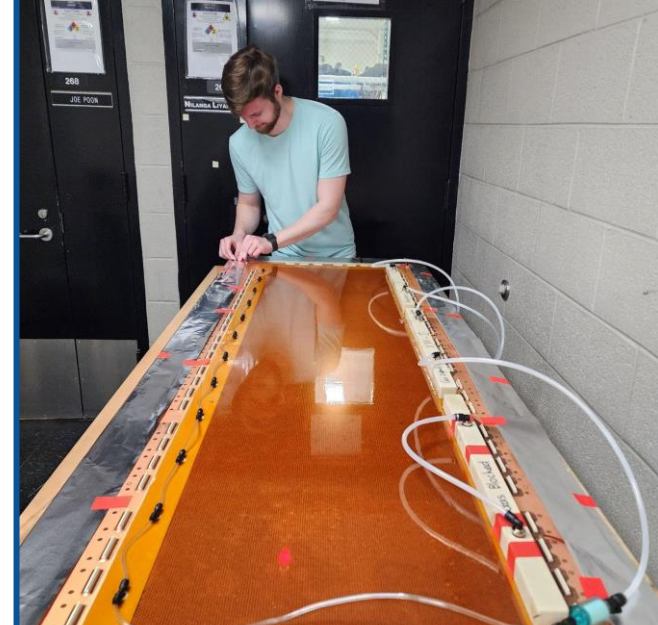
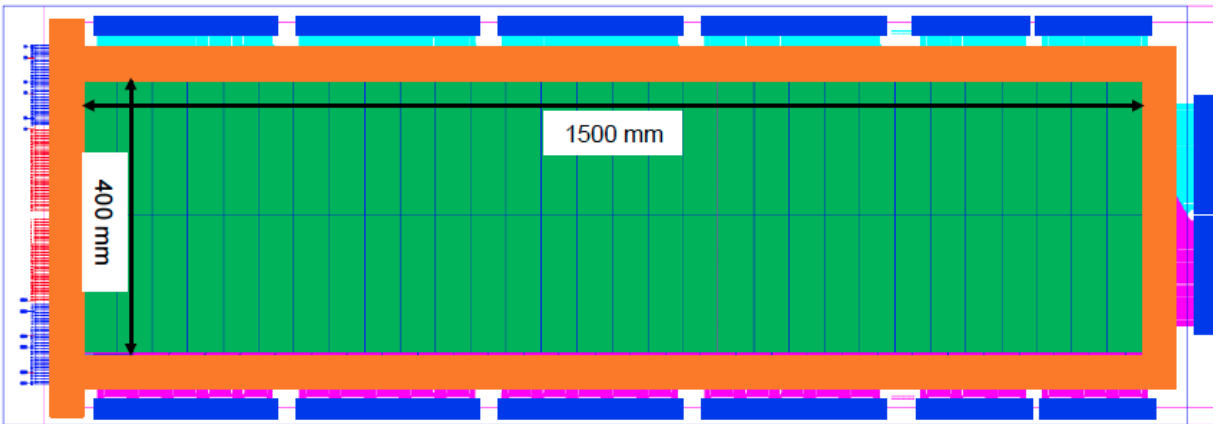



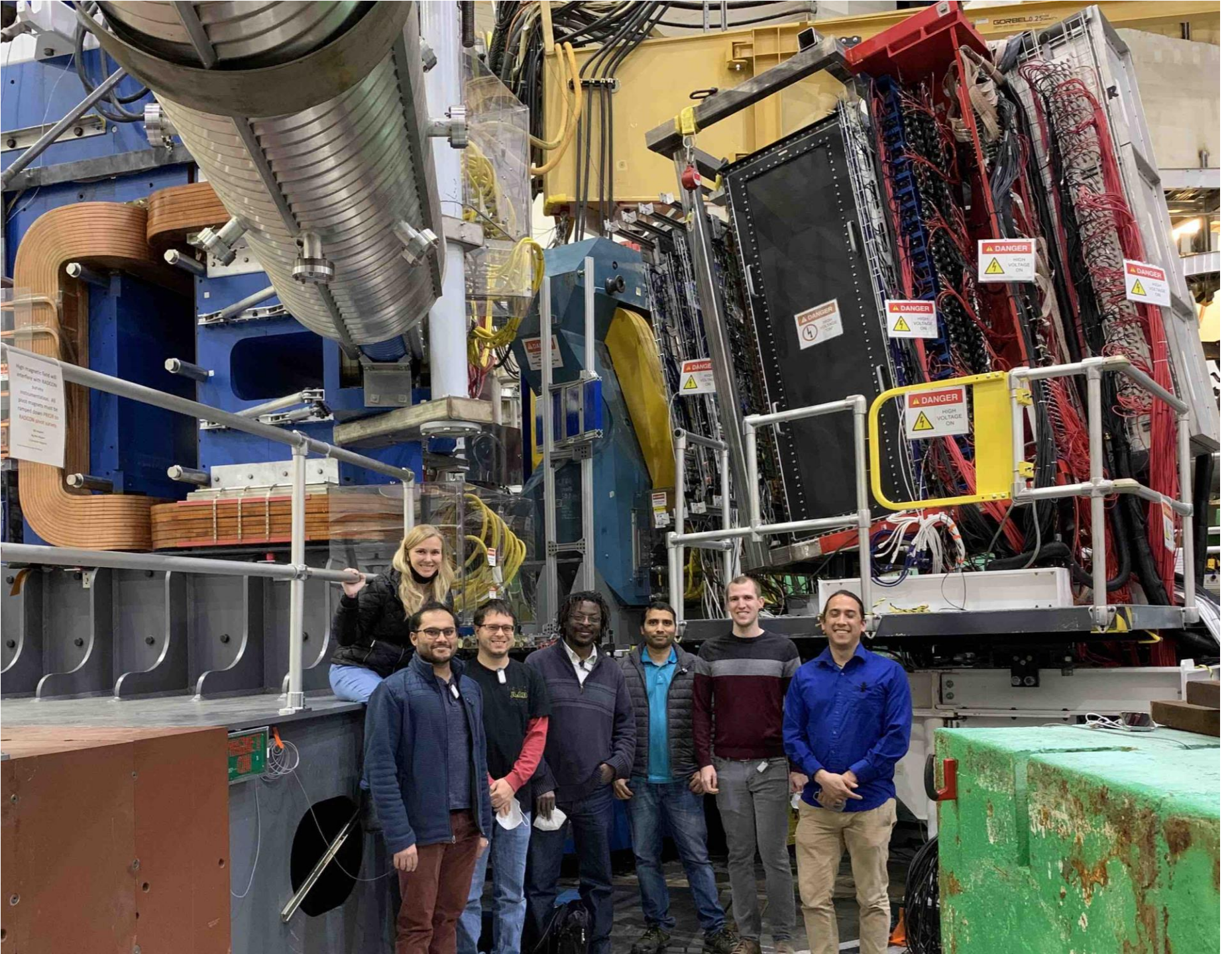

High magnetic field and  
interference with MAGNET  
systems.  
Unauthorized access, all  
personnel must be  
temporarily removed from  
MAGNET area unless  
authorized.

**DANGER**  
HIGH VOLTAGE  
ON

**DANGER**  
HIGH VOLTAGE  
ON

**DANGER**  
HIGH VOLTAGE  
ON

**DANGER**  
HIGH VOLTAGE  
ON

**DANGER**  
HIGH VOLTAGE  
ON

**DANGER**  
HIGH VOLTAGE  
ON

DOBELD 250





16 layers of SBS GEM  
installed in experiment:

- Forty 50 cm x 60 cm GEM modules in 10 layers
- Six 150 cm x 40 cm large GEM modules



# 4 UV and 1 XY have been running successfully in BigBite since 2021

Layer 0

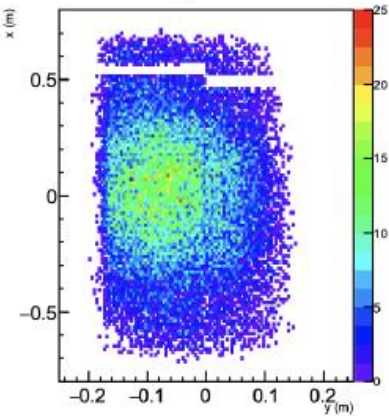

Layer 1

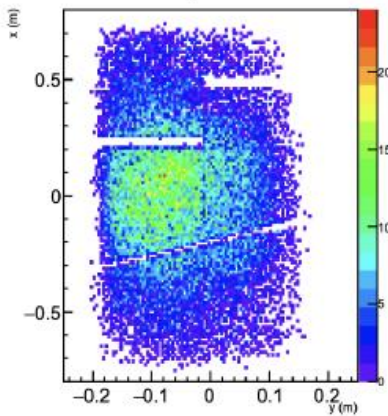

Layer 2

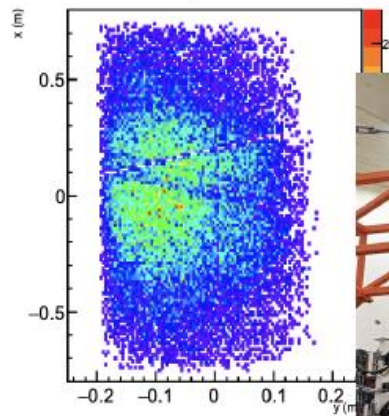

Layer 3

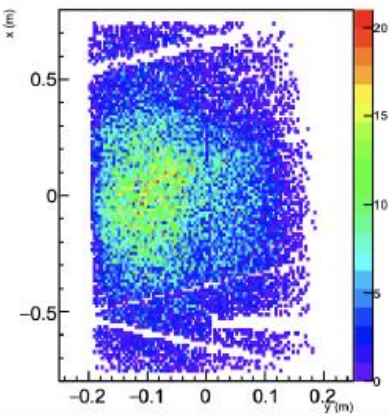

Layer 4

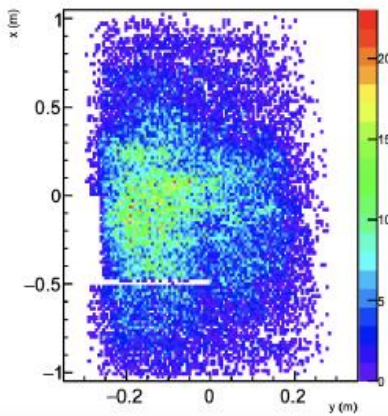

Hit maps  
tracking con:  
shown per

Tracking resolution  
76  $\mu\text{m}$

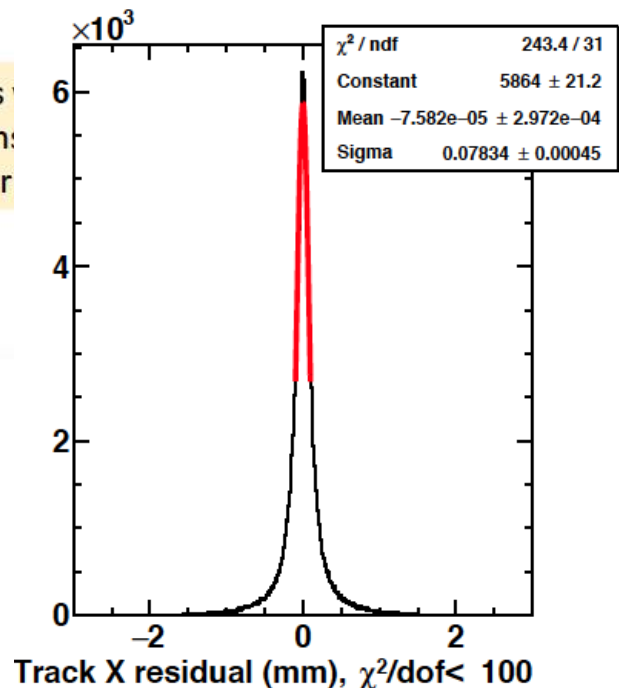
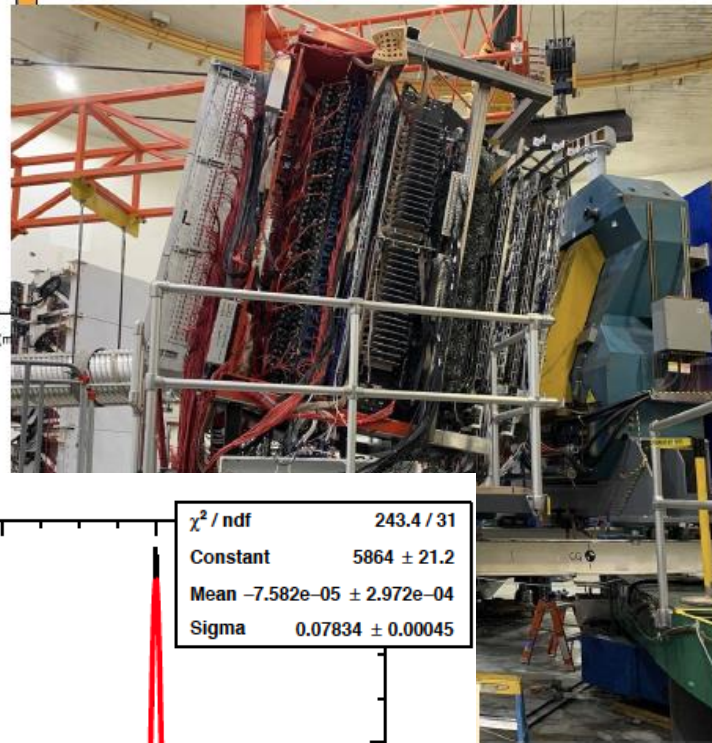



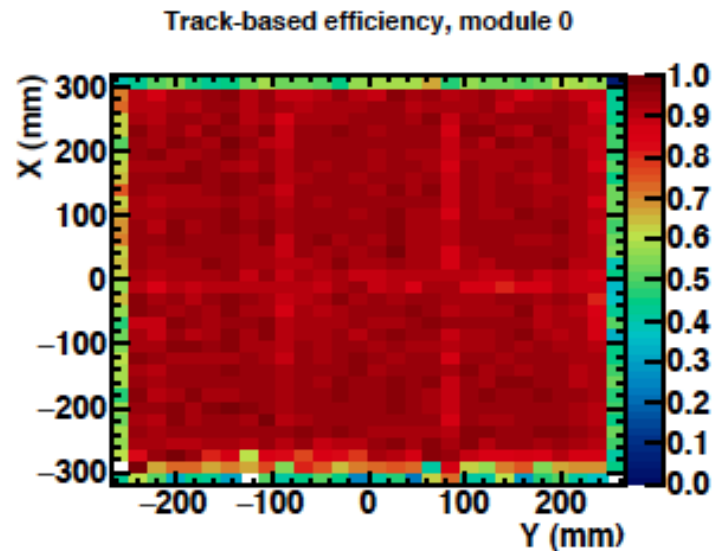
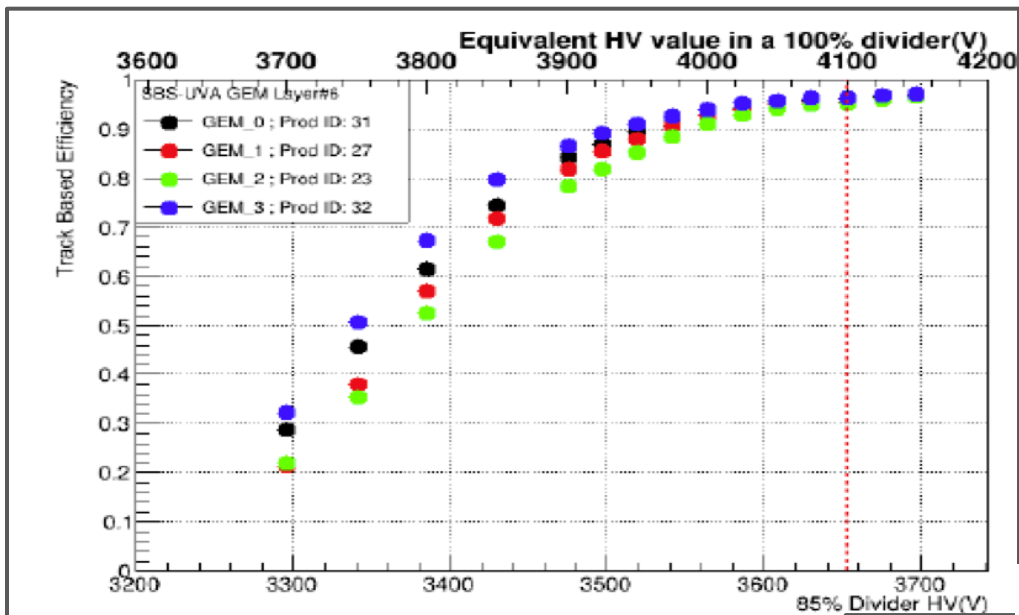

While GEM efficiency is > 95%, tracking efficiency drops under very high background/occupancy conditions

File View Edit Format Help

slot 2D fiber 23 Online Hits Layer: 0 Online Hits Layer: 1 Online Hits Layer: 2 Online Hits Layer: 3 Online Hits Layer: 4 Detector 2D Strip

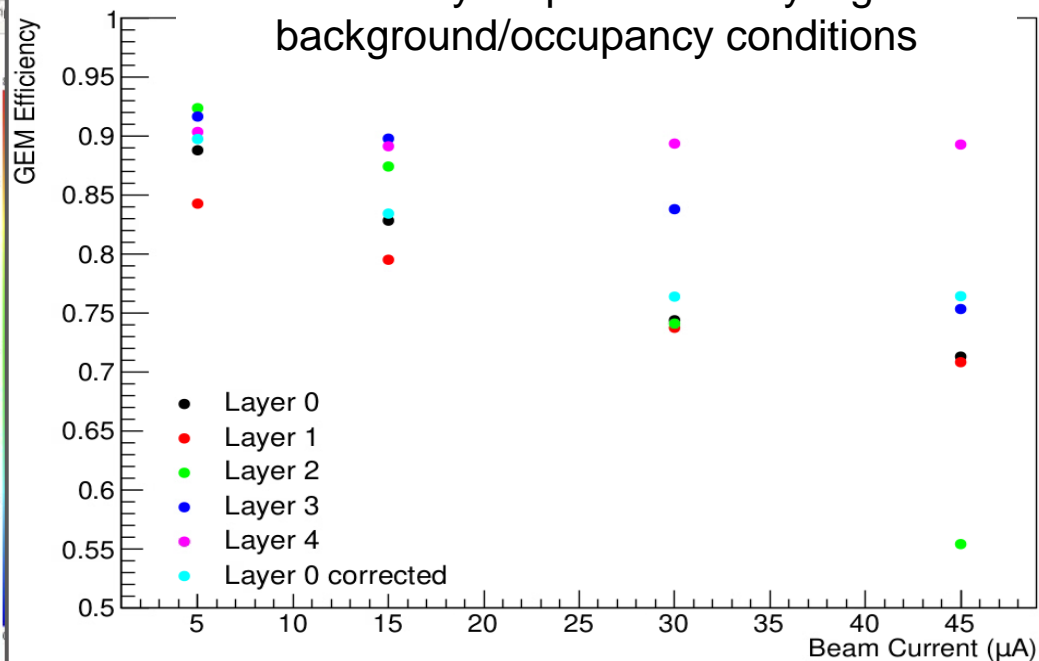
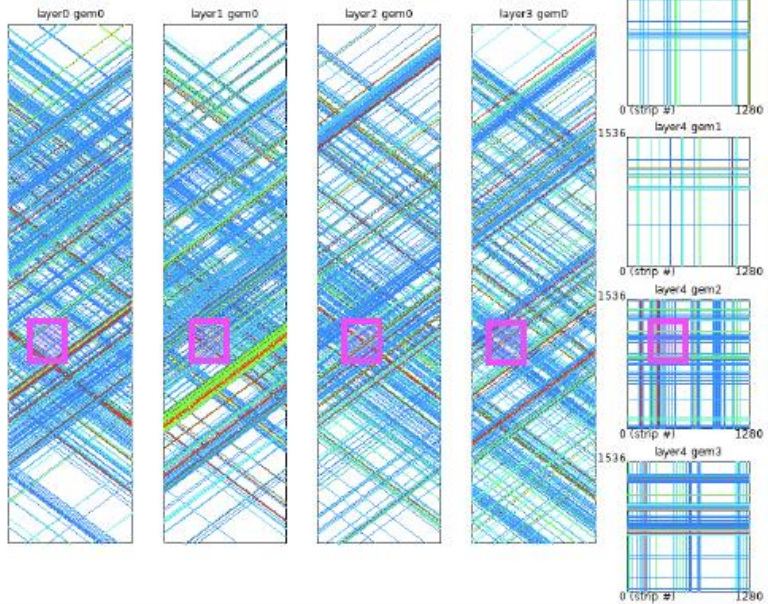

Efficiency vs. Beam Current

# Another major issue due to high charged hit rates: large current draw by the GEMs.

- As much as 500  $\mu\text{A}$  drawn by G3
- High current draw from resistive divider reduces the voltages to the GEMs: major gain drops with increasing luminosity.
- Solution: use of CAEN multichannel GEM HV supply. Now installed for all SBS GEMs

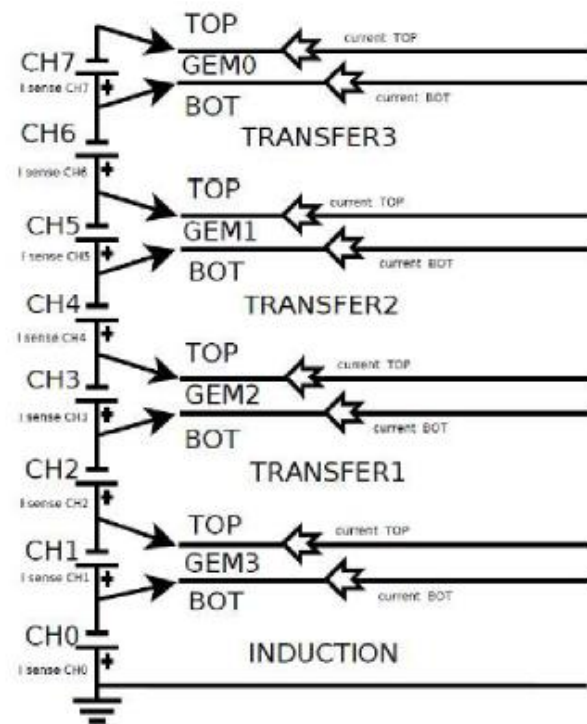
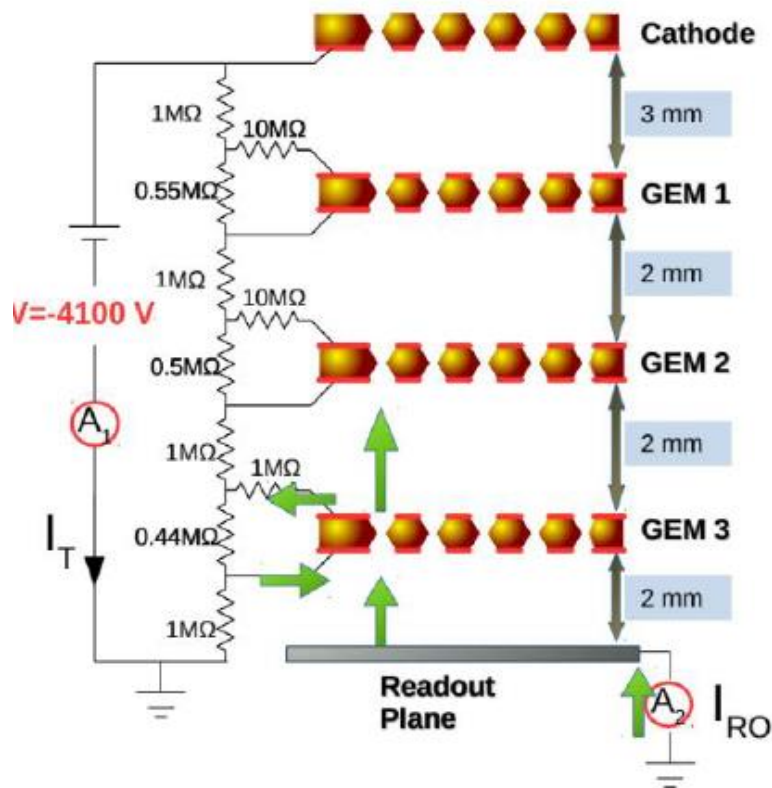
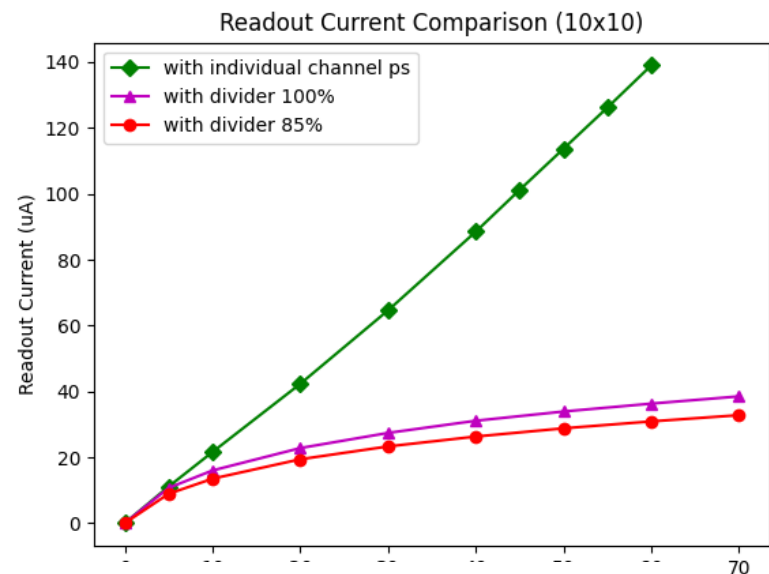



# GEMs for MOLLER experiment at Jefferson Lab

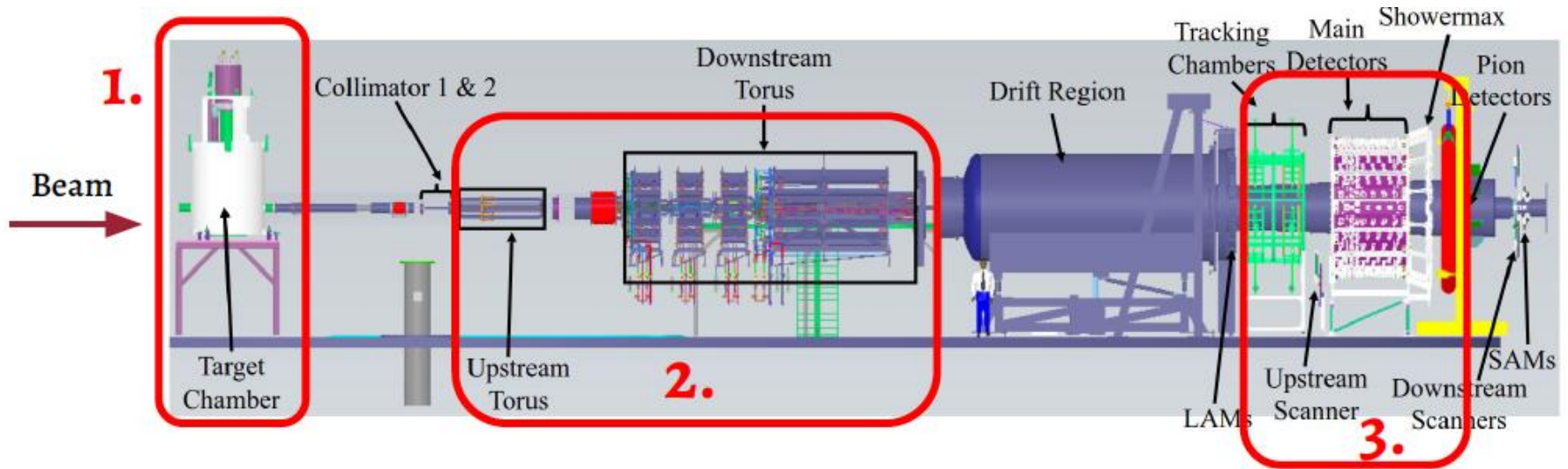

- The rate during production in GHz: need integrating detectors.
- But Precision coordinate detection is needed for calibration of the Setup.
- GEMs: a good choice
- Calibration to be done with  $\sim 100$  nA beam; highest local rates around  $100$  kHz/cm<sup>2</sup>
- GEMs need to be moved out of the way to avoid damage during production

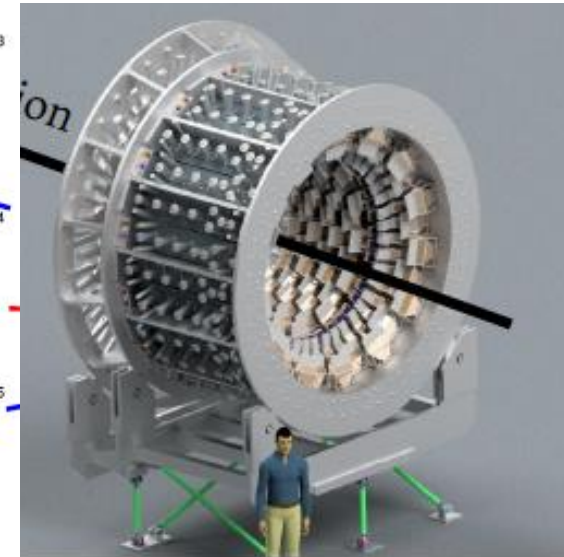
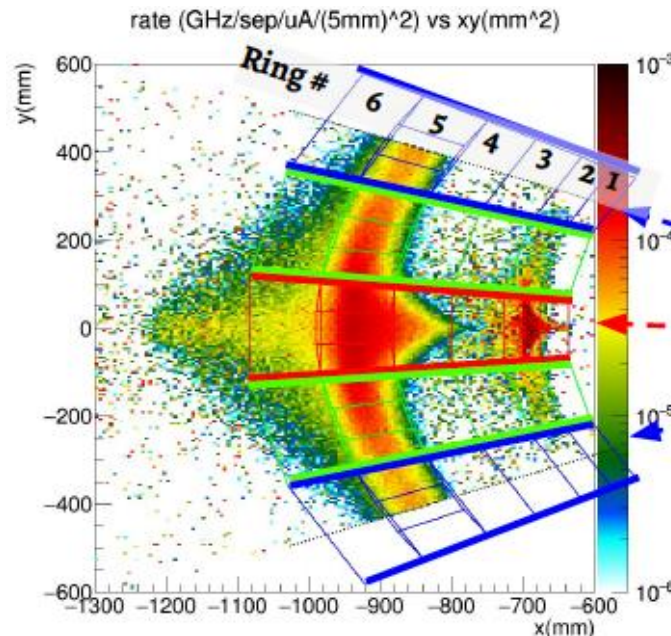

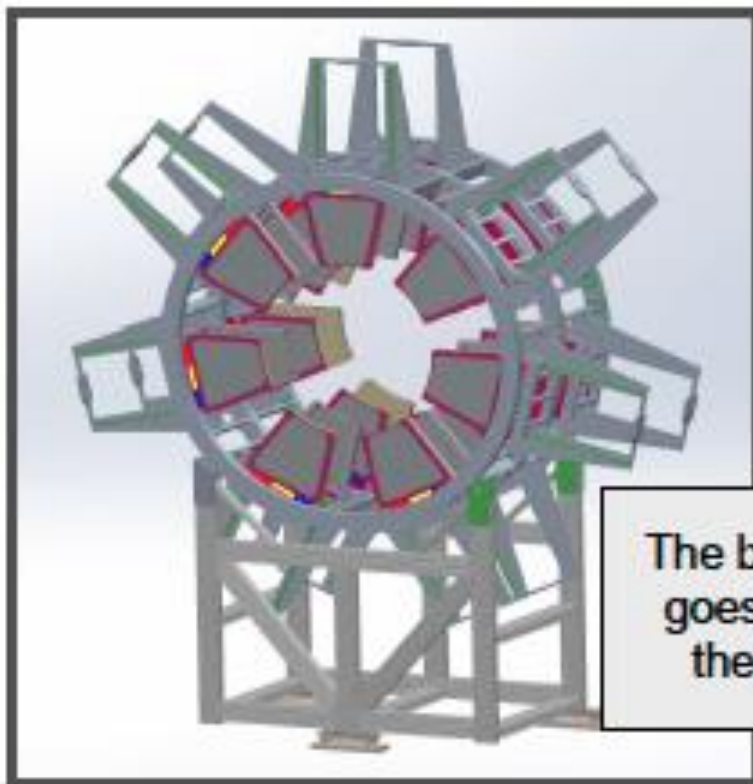

**GEM Module Rotator Orientation during Calibration runs**

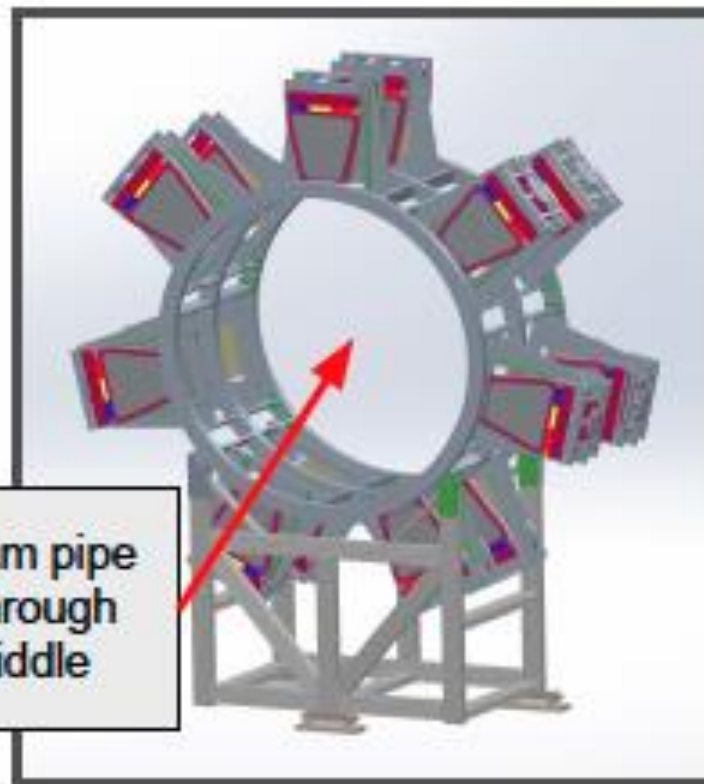

**GEM Module Rotator Orientation during Production runs**

The beam pipe goes through the middle

- 4 GEM tracking layers, **7 trapezoidal shaped** detectors at each layer
- Only 50% azimuthal coverage cuts down overall costs
- GEM layers can be rotated around the beam pipe axis
- Pulled out during production runs (as shown above)
- Different geometric requirements for each layer - one single design to match with all 4 layers

### The work at UVa

- **Engineering Design** of GEM tracking detector module
- **Prototyping and Testing** of GEM tracking Modules
- Engineering Design of GEM **Polarimeter**
- **Mass fabrication** of **16** (+2 spares) out of **28** (+4 spares) total tracking detector modules
- **Fabrication** of **2** GEM Polarimeters
- **Commissioning, Operation** and **Data Analysis**

\*Rotator\* Image courtesy - Chandika Annasiwatti



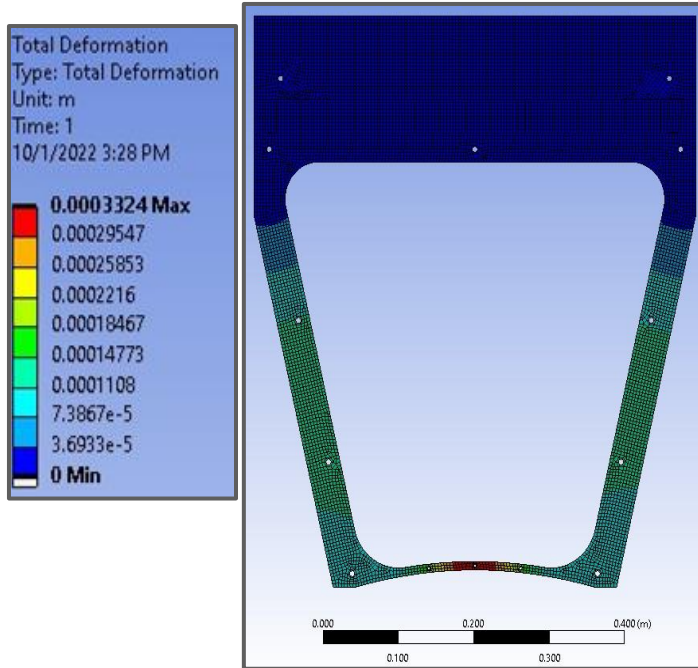

Deflections of the module  
under 3(safety factor) times total foil stress  
(without the Carbon fiber mounting frame)

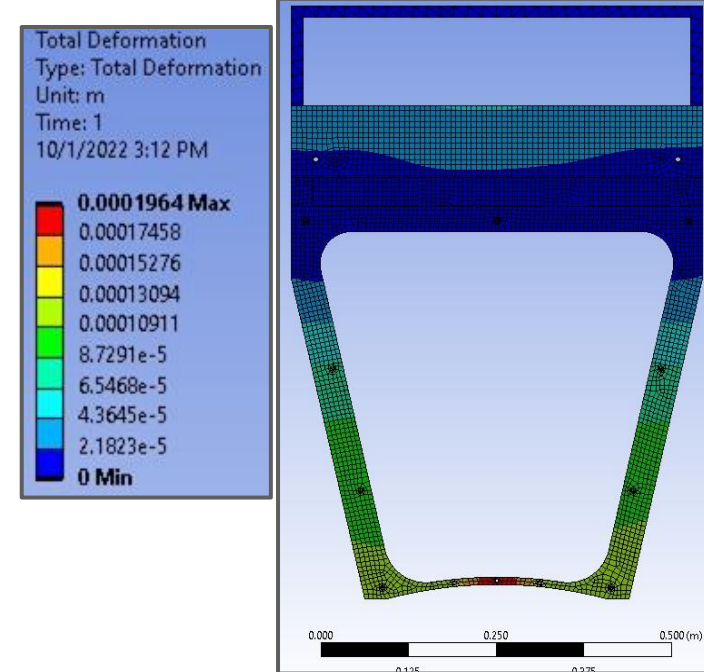

Deflections of the module  
under 3(safety factor) times total foil stress  
(with the Carbon fiber mounting frame)

Beam side of the frame has to be very thin and curved not to miss any acceptance. We did a FEA calculation to study the distortion of the thin inner arc under stress from the GEM foil tension. For this arrangement the deformation was 340 microns; within acceptable limits.

# 3-D CFD Simulation study of the internal Gas Flow

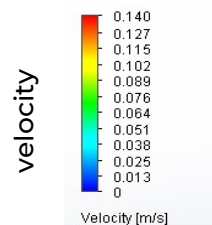
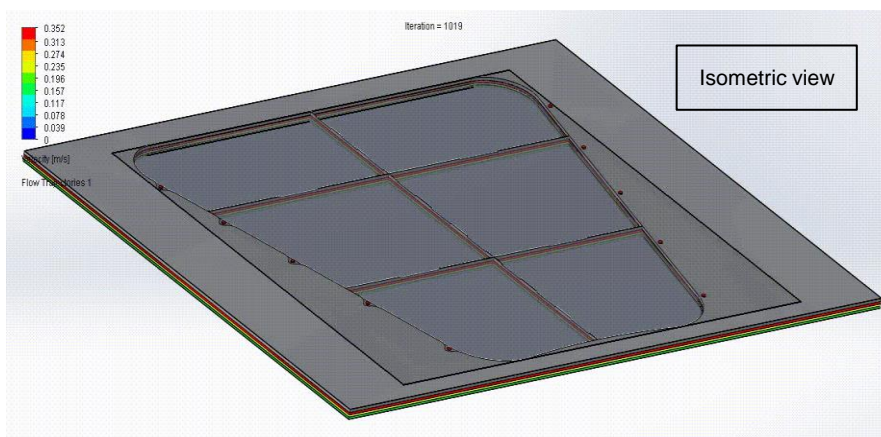

On GEM foil 3

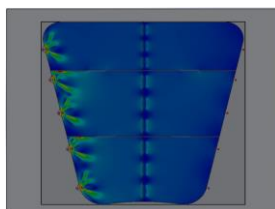

On GEM foil 2

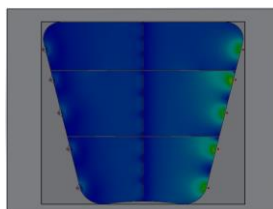

On GEM foil 1

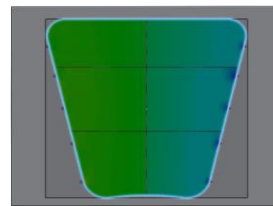
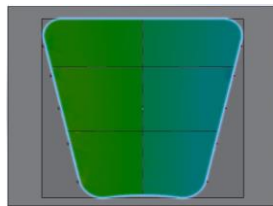
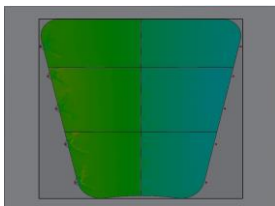
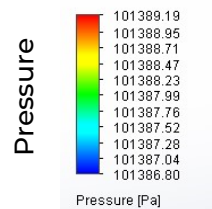
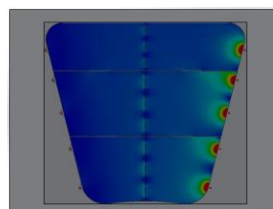

- Gas used: A mixture of 70% Argon and 30% Carbon dioxide
- Smooth gas flow is necessary for good chamber uniform efficiency
- Regions with lower gas circulation will likely lead to lower efficiency and increased aging.





# MOLLER coordinate GEM prototyping progress

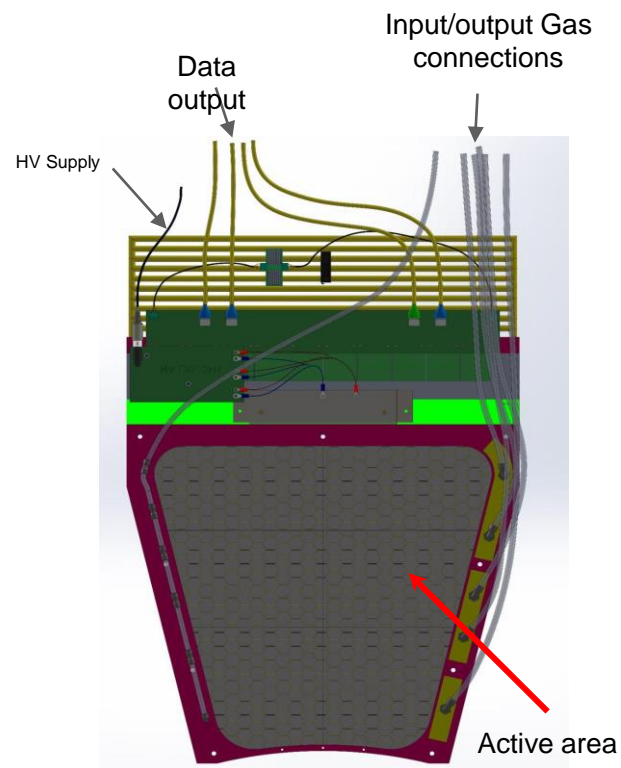

Module Front View with Components

- The CAD design based on the SBS GEM design.
- Improvements to module design, gas flow, HV, s expe

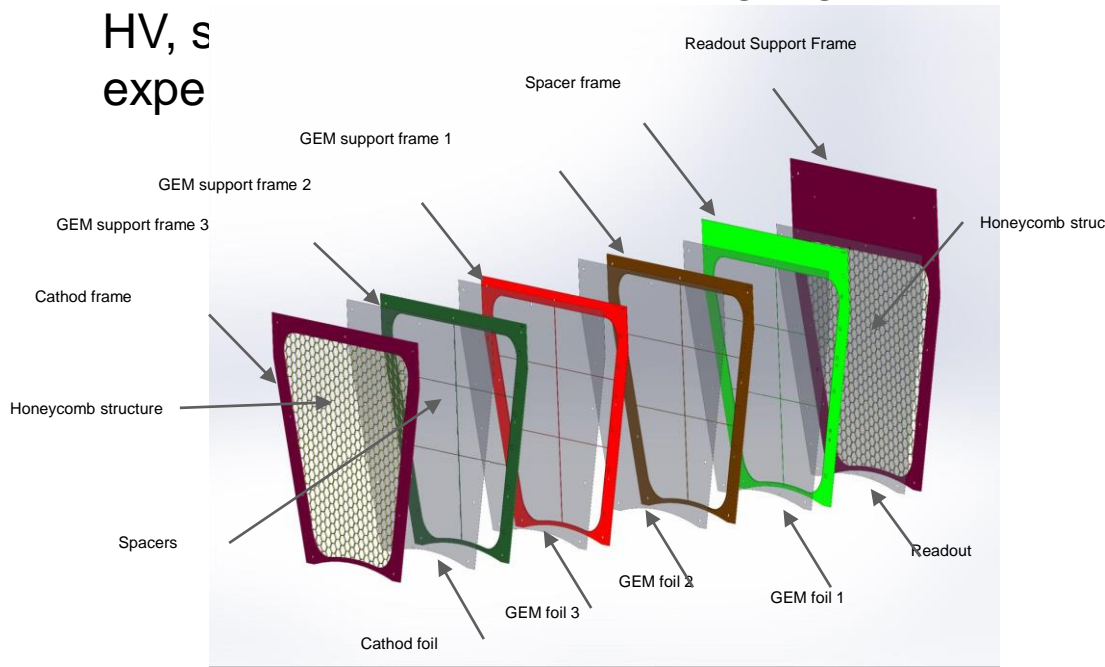

Exploded View with Basic Components



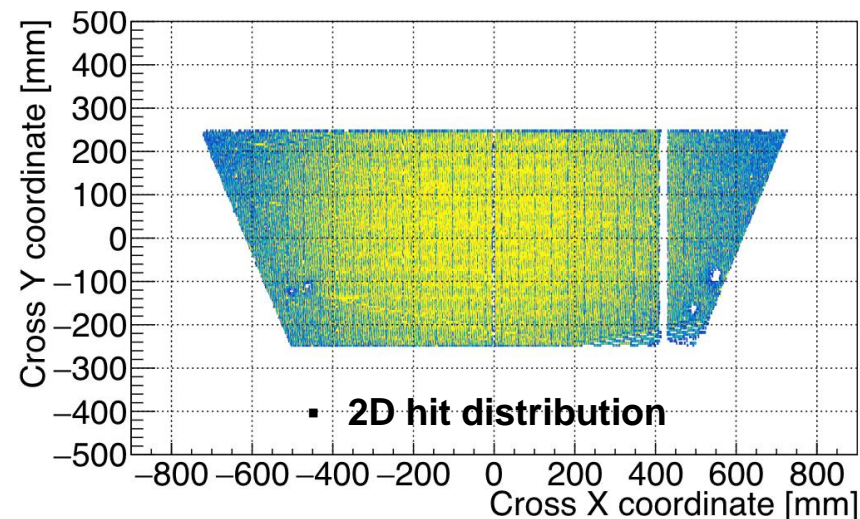
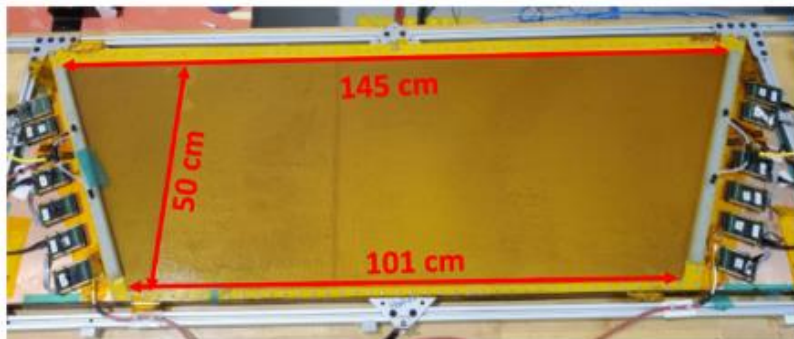

## ❖ Large-area $\mu$ RWELL with 2D-strip readout

- Active area: 50 cm x (101 cm x 145 cm)
- U and V readout layers oriented  $10^\circ$  with respect to the base of the detector
- Primarily built to study the impact of its large size and long readout strips on the overall performance of the detector

## ❖ Studied intensively with cosmic

- 98% of the detector active area is functional
- Overall gain is reasonably uniform



# Efficiency of Large-area $\mu$ RWELL Prototype

Ar/CO<sub>2</sub> (80:20)

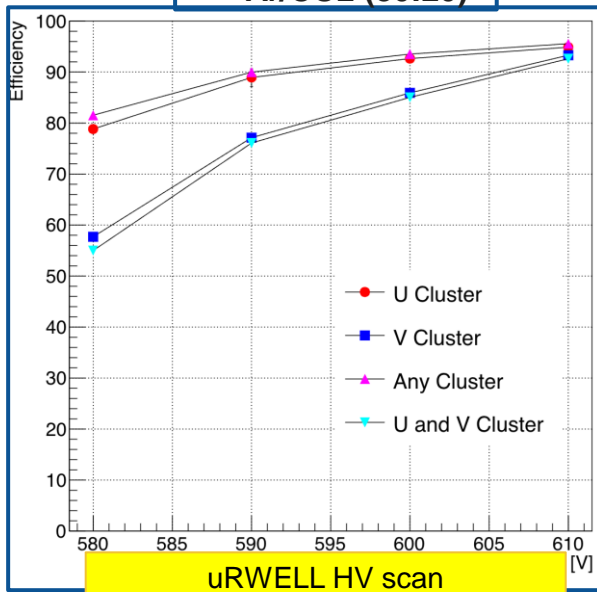

Ar/C<sub>4</sub>H<sub>10</sub> (90:10)

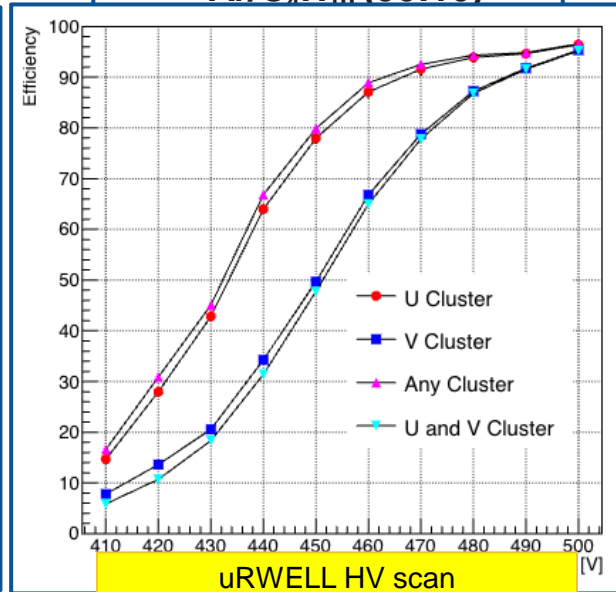

- ❖ Detection efficiency of the bottom readout layer is significantly lower than top readout layer
- ❖ Prototype reached 90% efficiency in Ar/C<sub>4</sub>H<sub>10</sub> (90:10) at a much lower HV (490 V vs. 600 V) => operated much more stably

- ❖ Plan to install the detector into Hall B to take beam data and check its high-rate capability.
- ❖ In discussion of building a new version of the large detector as a pair of 1D detectors facing each other, each with the same trapezoidal active area (145 cm × 101 cm) × 50 cm





# GEM-TRD Prototype for GlueX Experiment

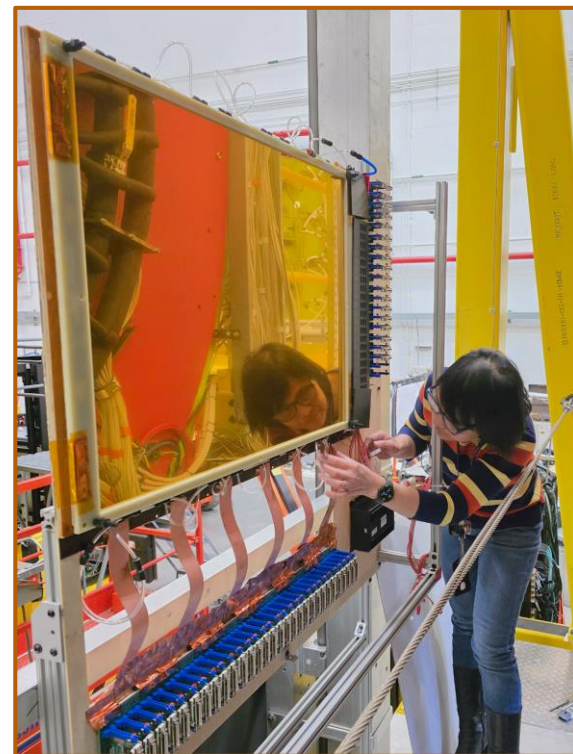
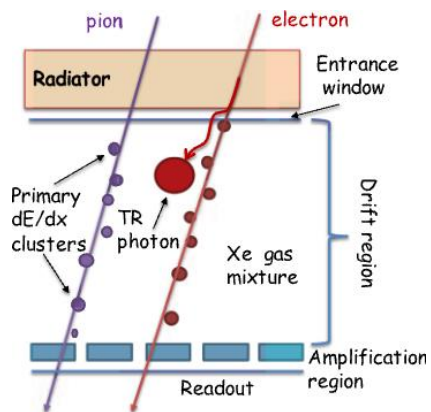
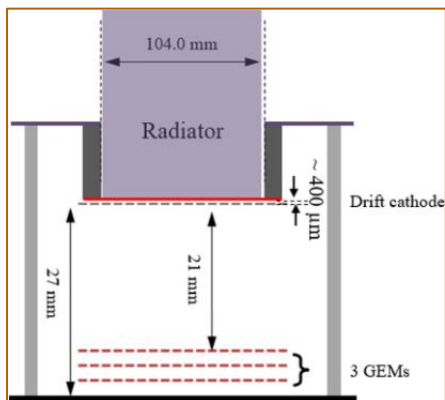

## ❖ GEM-TRD Prototype

- Combination of TRD functionality with the high granularity and high-rate capability of GEM trackers for high-luminosity experiments at JLab
- Used for electron identification or hadron suppression, particularly in high-luminosity experiments at JLab and EIC
- Active area: 52 cm × 72 cm
- Being tested with electrons in Hall D using a Krypton gas mixture. S



# GEM-Pixel Detectors for GEn Experiment

## ❖ Issues with intense low-energy photon background at SBS

- Photon conversion hits increase the occupancy of the GEM trackers
- Problem especially severe for strip readout due to false x-y combinations
- Too costly for fine pixel readout
- Increased difficulty in track reconstruction and reduced the overall efficiency of the tracking system.

## ❖ Solution: Adding coarse pixel detectors in combination with strips

- Building two GEM detectors with  $9 \times 9 \text{ mm}^2$  pixel readout and active area of  $40 \times 150 \text{ cm}^2$
- Hits from low-energy photons tend to produce single-tracker-layer hits without correlated signals across independent tracker layers
- Having two pixel detectors at the front and back of the SBS tracker system and applying a coincidence condition between them to differentiate random photon conversion hits from high-energy track hits.
- Accelerate the track-finding process by narrowing the search area for hits in the subsequent 2D-strip-readout GEM trackers

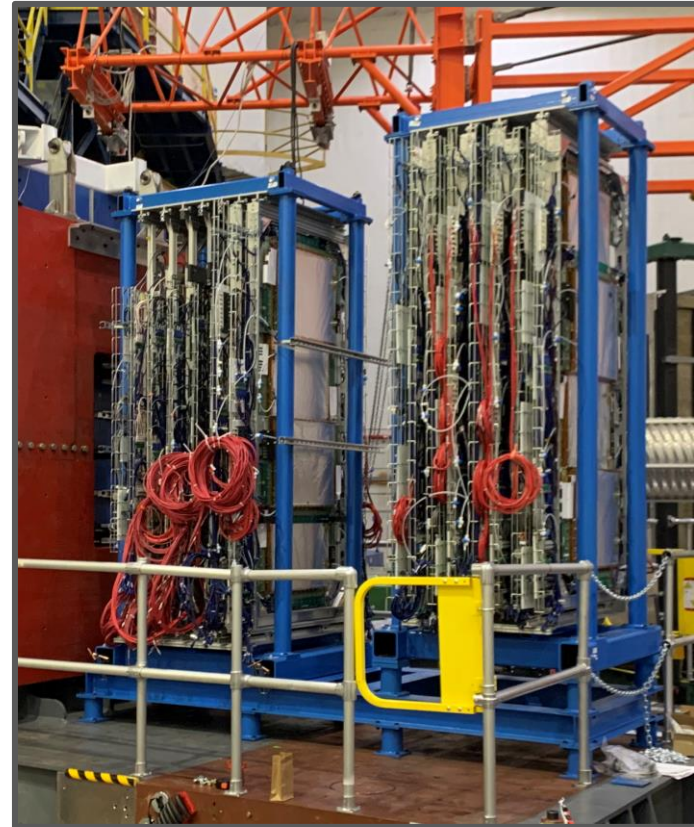



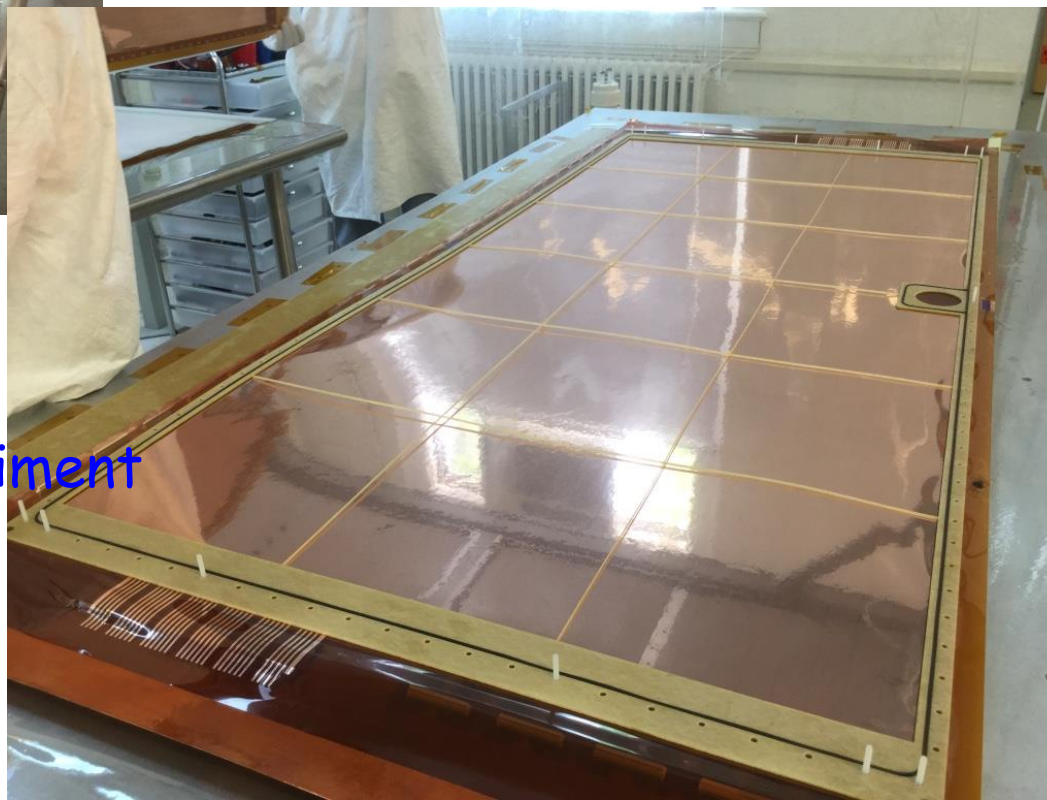
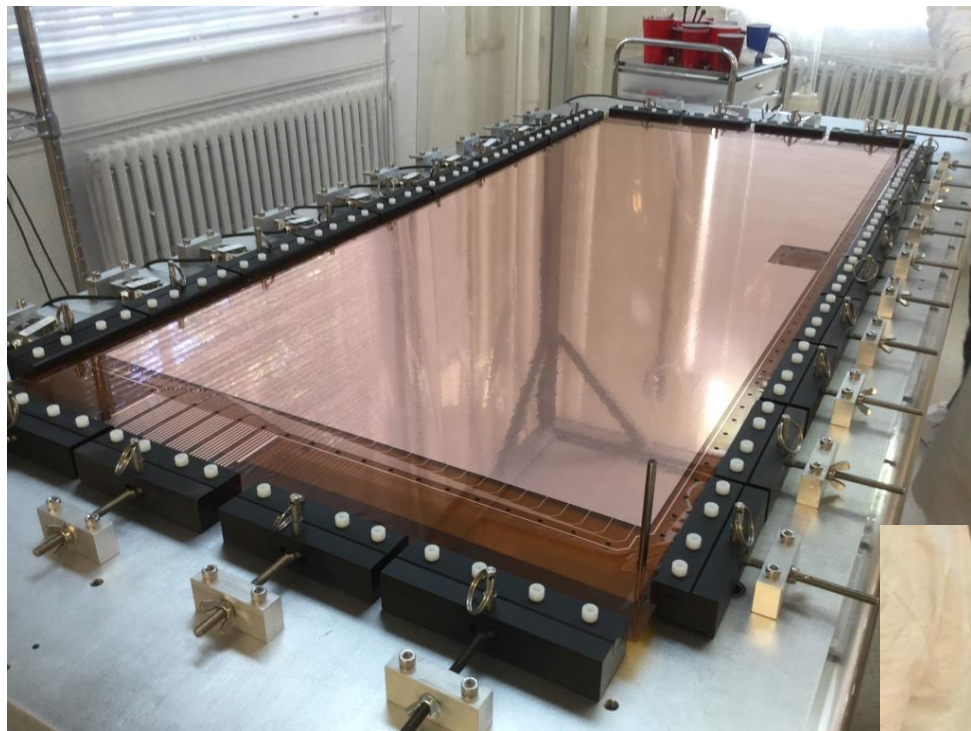

123 cm x 55 cm active area  
GEM detectors for pRad experiment  
during construction at UvA

# pRad GEMs

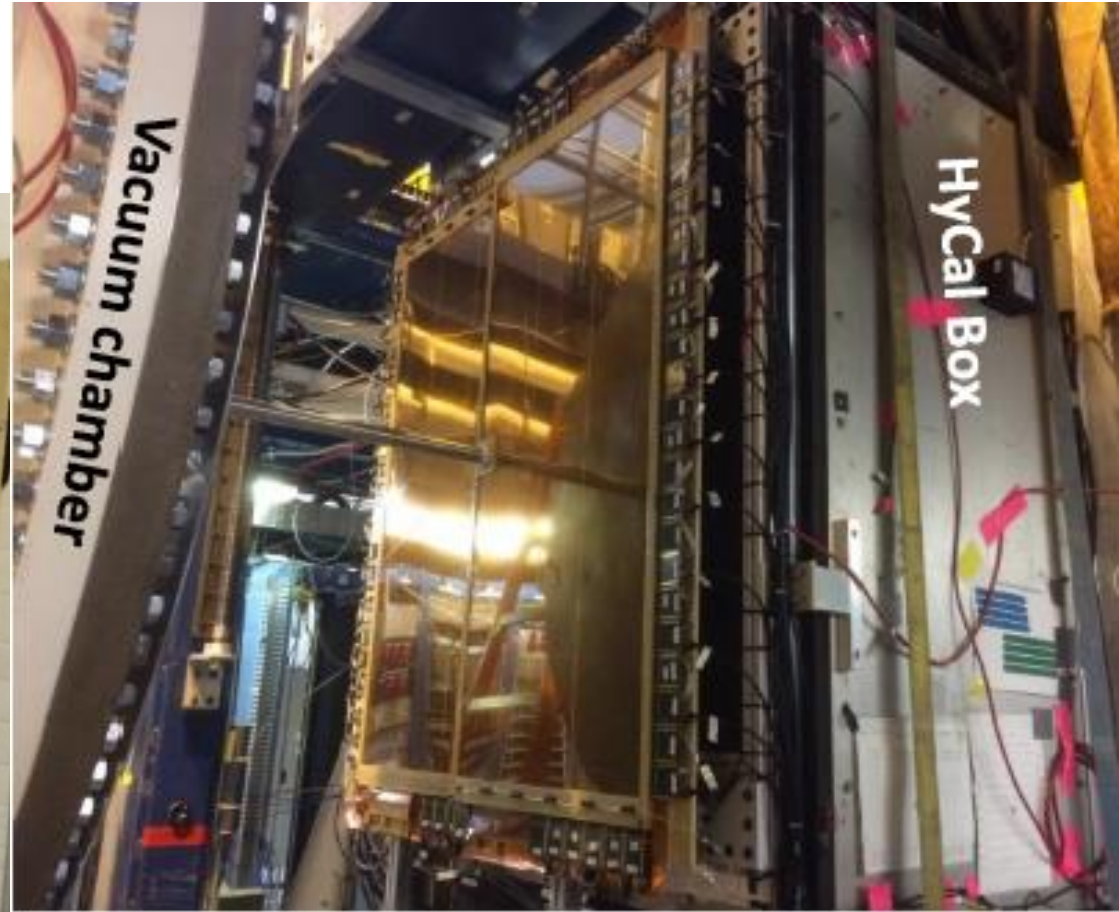
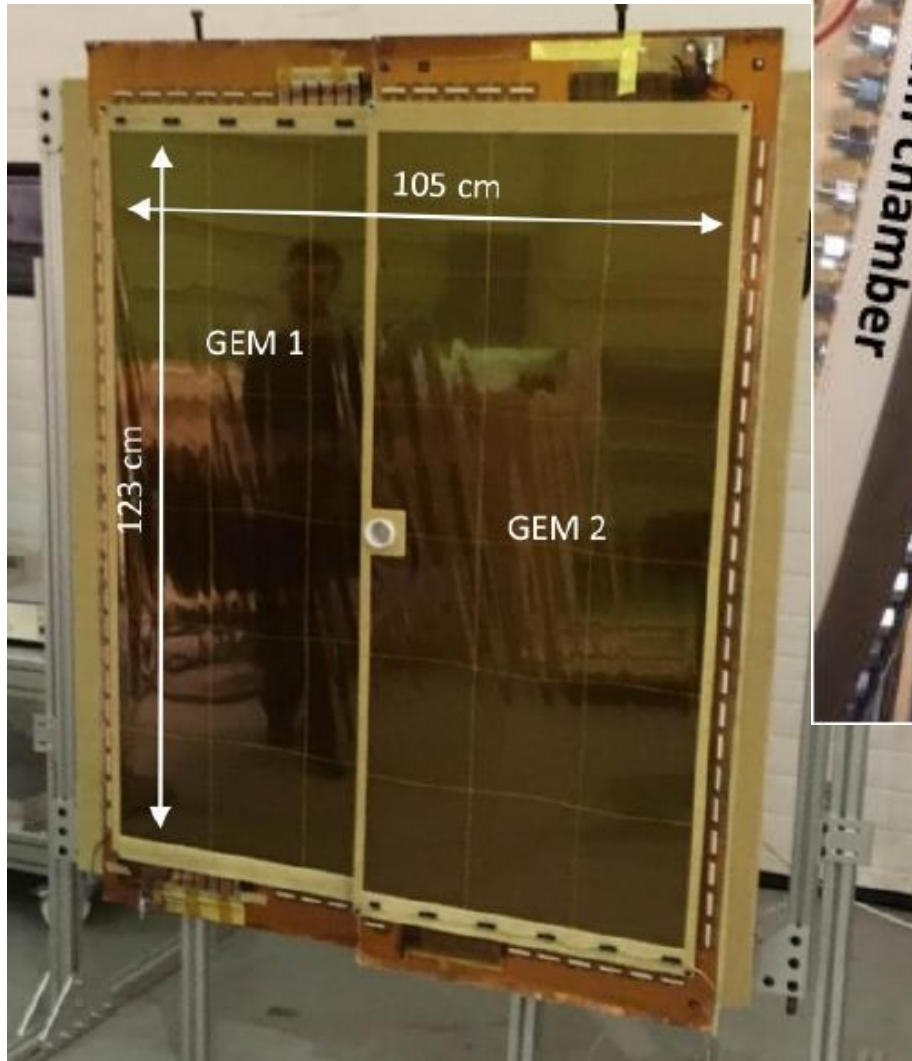



# pRad GEMs - Results

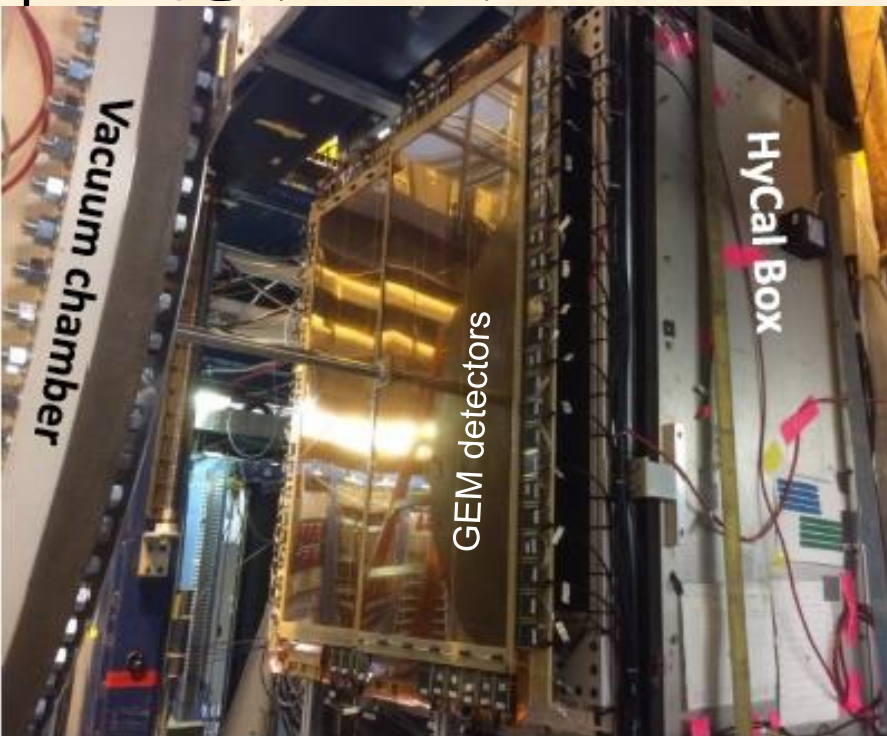

Using coordinates from GEM detectors, and energy from calorimeter.

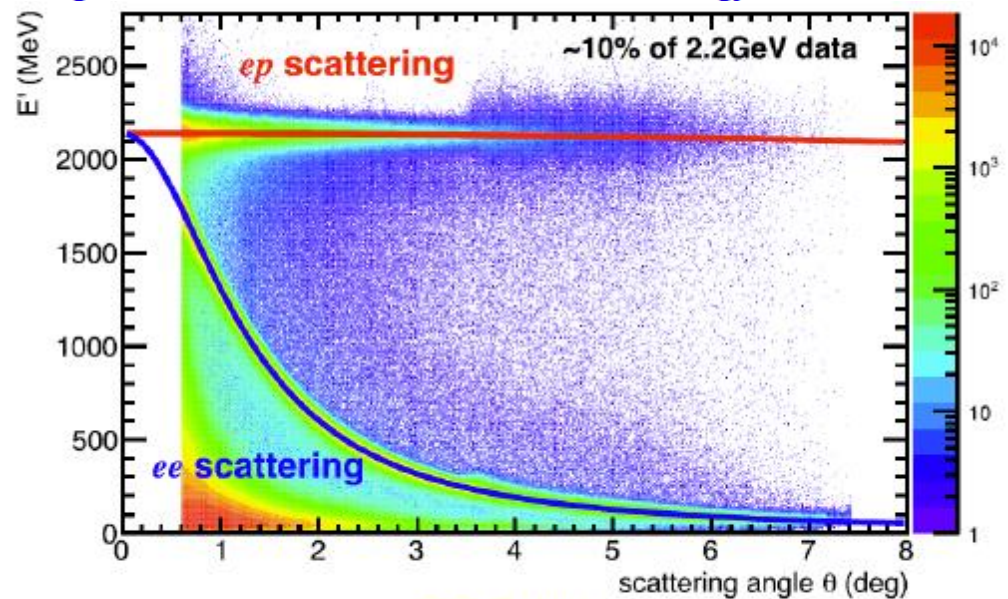

2.2 GeV beam

GEM efficiency as a function of time

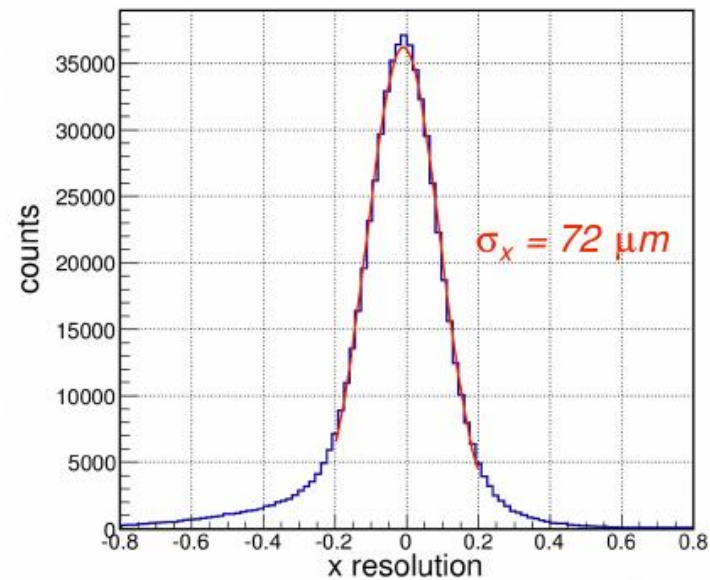
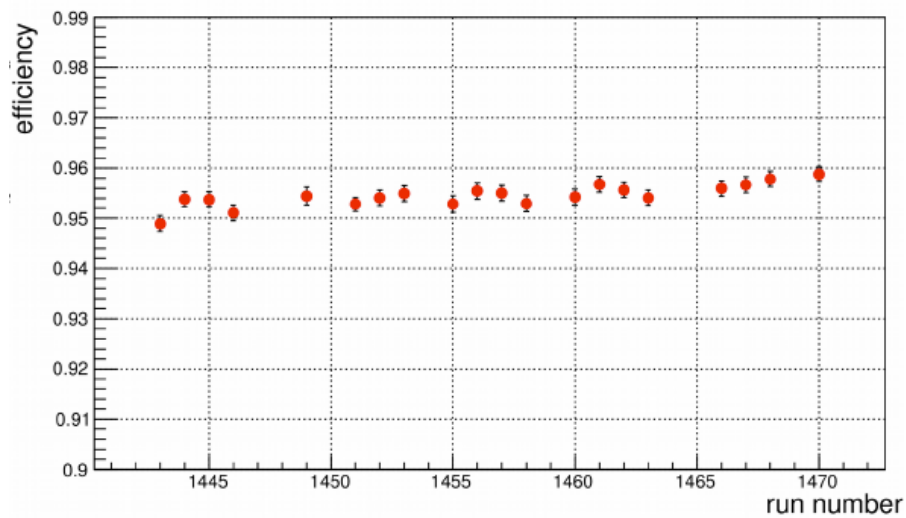

## Simulations

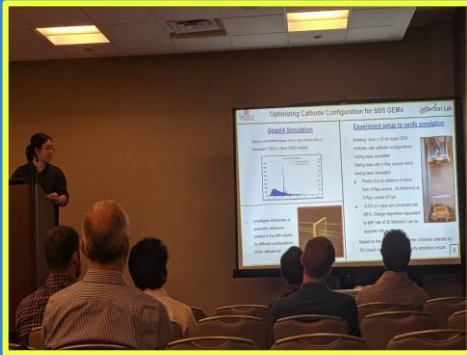

## Design & Construction

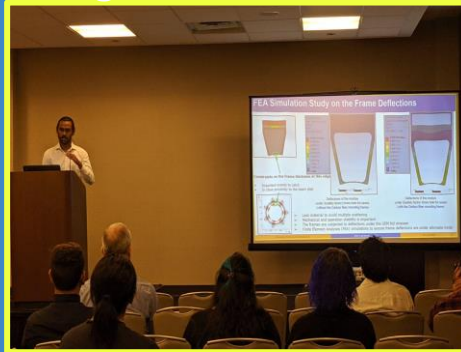

## Characterize & Commission

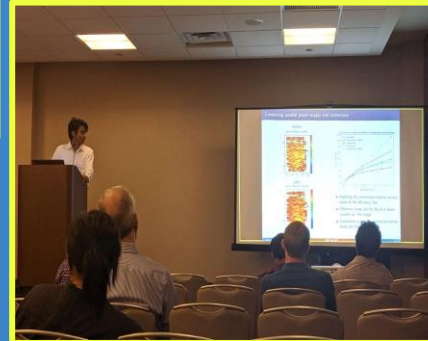

## Data & Physics Analysis



A BIG thank you to Rui and his team for providing us with excellent quality foil, readouts, valuable advise and innovation

### Liyanage-Nguyen MPGD Group at UVA

- ⇒ Six (6) Grad Students & One (1) Undergrad
- ⇒ Two (2) Technicians (Mechanical & Electrical)
- ⇒ Two (2) Post-docs
- ⇒ Two (2) professors
- ⇒ And close collaboration with former colleague Kondo Gnanvo



# Conclusion

- At the University of Virginia we have a very active MPGD production and R&D program
- Traditionally our interests have been in large area MPGDs and MPGDs to work under high rates and highly ionizing conditions.
- Now we are also working in the areas of thin-gap MPGD, GEM-TRD, and wire-amplification detectors.
- We have had very close collaboration with RD51/DRD1 and looking forward to continuing this collaboration.

Backup



## GEM foil quality assurance

- ❑ Visual inspection of the foil upon arrival from CERN. If there is any sign of damage:
  - ❑ inspect the area under the microscope. If damage is confirmed, set the foil aside and return to CERN.
  - ❑ If there are minor issues such as local discoloration, spots etc. refer the foil or sector for microscope and special attention during high voltage testing
- ❑ High voltage testing of all sectors at three different stages: in the raw foil, in the framed foil and the foil in the module.

## GEM foil quality assurance: sector testing in dry N<sub>2</sub> box

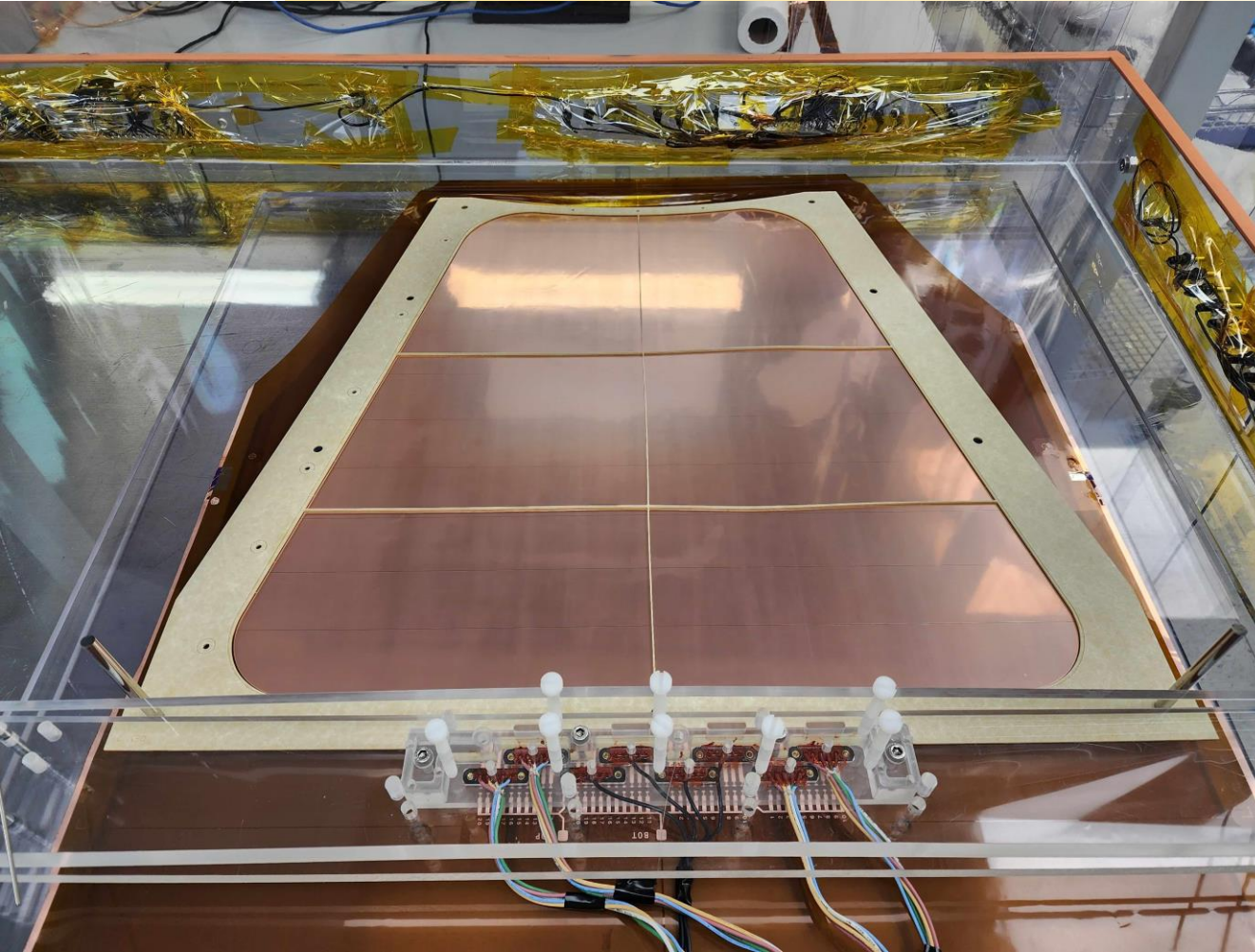

- Rapid HV ramp-up to 550 V.
- Significantly higher the voltage applied in operation ( $\sim 400$  V)
- At 550 V: the initial current is a few of  $\mu\text{A}$  (re: capacitance of the sector).
- Then quickly drops and stabilizes to  $\sim 1$  nA
- The test is done for raw foils, framed foils and foils in chamber



## GEM foil quality assurance

- ❑ Visual inspection of the foil upon arrival from CERN. If there is any sign of damage:
  - ❑ inspect the area under the microscope. If damage is confirmed, set the foil aside and return to CERN.
  - ❑ If there are minor issues such as local discoloration, spots etc. refer the foil or sector for microscope and special attention during high voltage testing
- ❑ High voltage testing of all sectors at three different stages: in the raw foil, in the framed foil and the foil in the module.
  - ❑ require leakage current to be less than 5 nA: if raw foil fails test, set the foil aside and return to CERN.

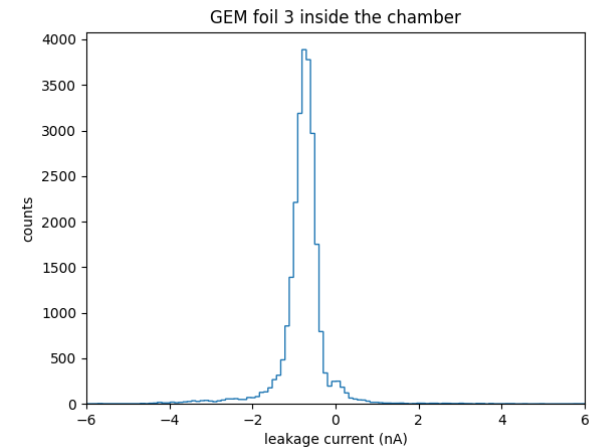
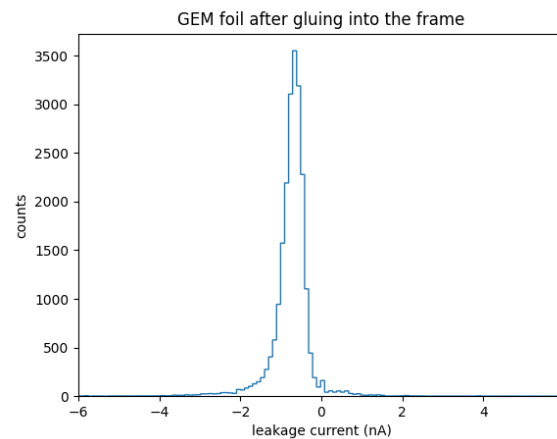
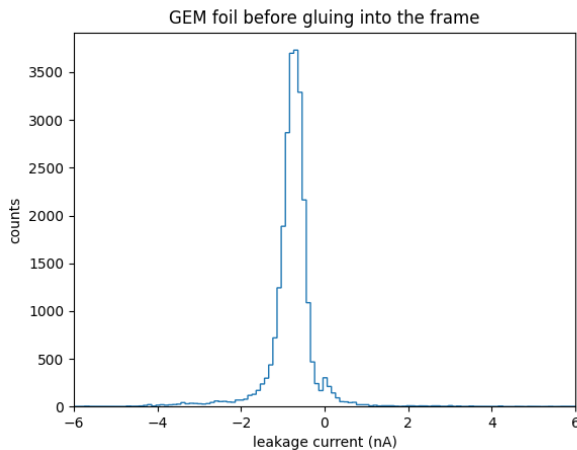

## Readout foil quality assurance

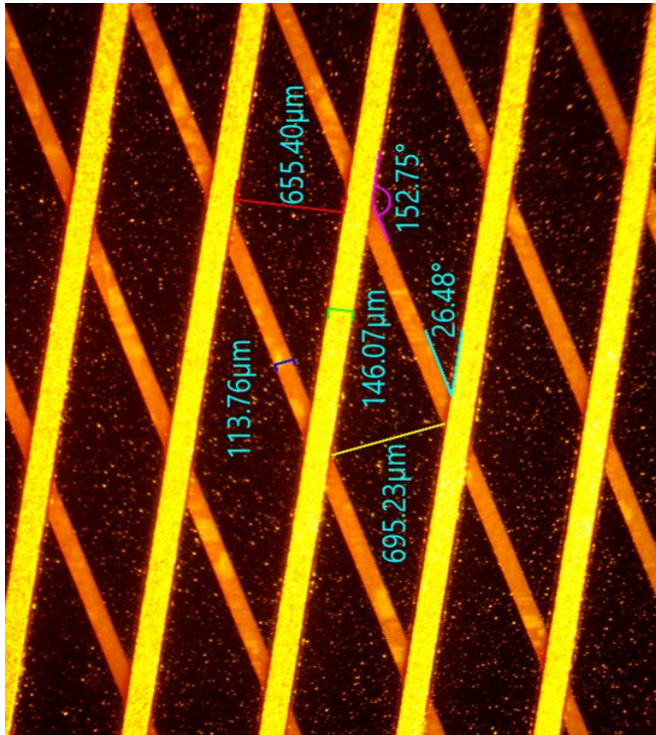

- ❑ Visual inspection upon arrival from CERN:
  - ❑ Check sensitive area and all connectors. Note any areas with possible issues for inspection under microscope.
- ❑ Inspection of readout strips under the microscope:
  - ❑ measure the readout strip width and strip pitch for both directions. Ensure that no Kapton is extending out from under the top readout strip layer.
  - ❑ If observations are not within specs, set the readout aside and return to CERN.
- ❑ Electronic pedestal noise test of the readout board:
  - ❑ Connect all connectors of the readout board to the APV-25 readout system and take pedestal data. Ensure that all channels have pedestal RMS values of 50 channels or less.

## Preparation of the frames

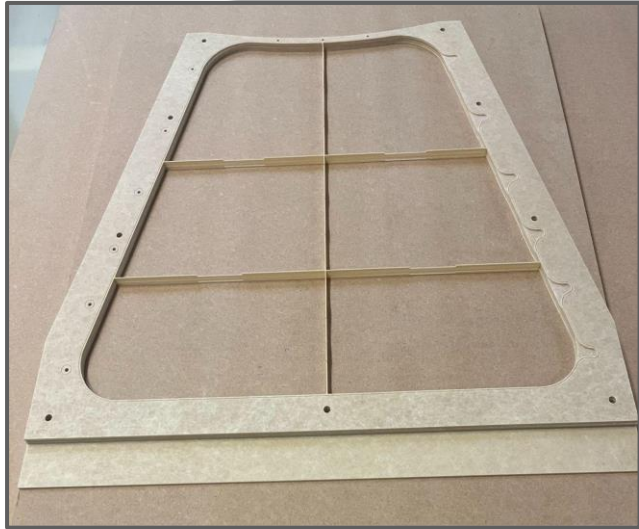

GEM frames (Permaglass))

Spacers sanded, then frames cleaned in Ultrasonic bath with demineralized Water

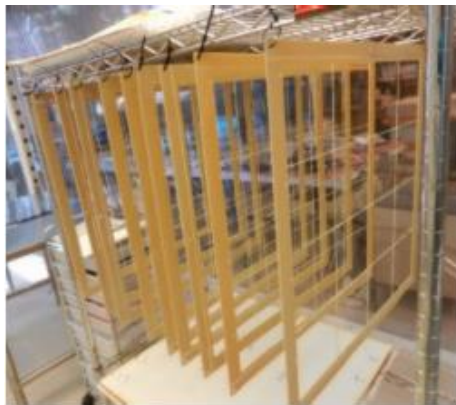
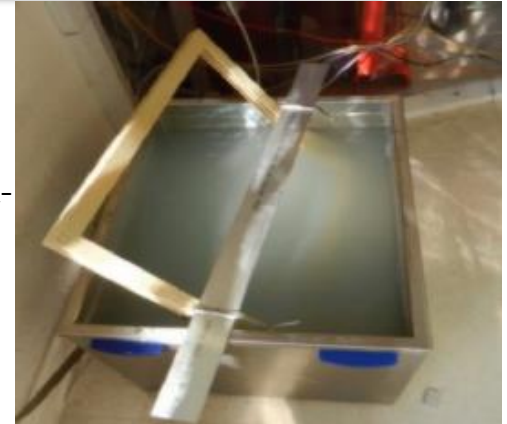

Dried for 4 days under a filter hood .



Machined surfaces sealed with a layer of polyurethane (Nuvovern LW) to prevent surface irregularities, residual fibers or sharp edges in the active area of the chamber



## Assembly: Foil stretching

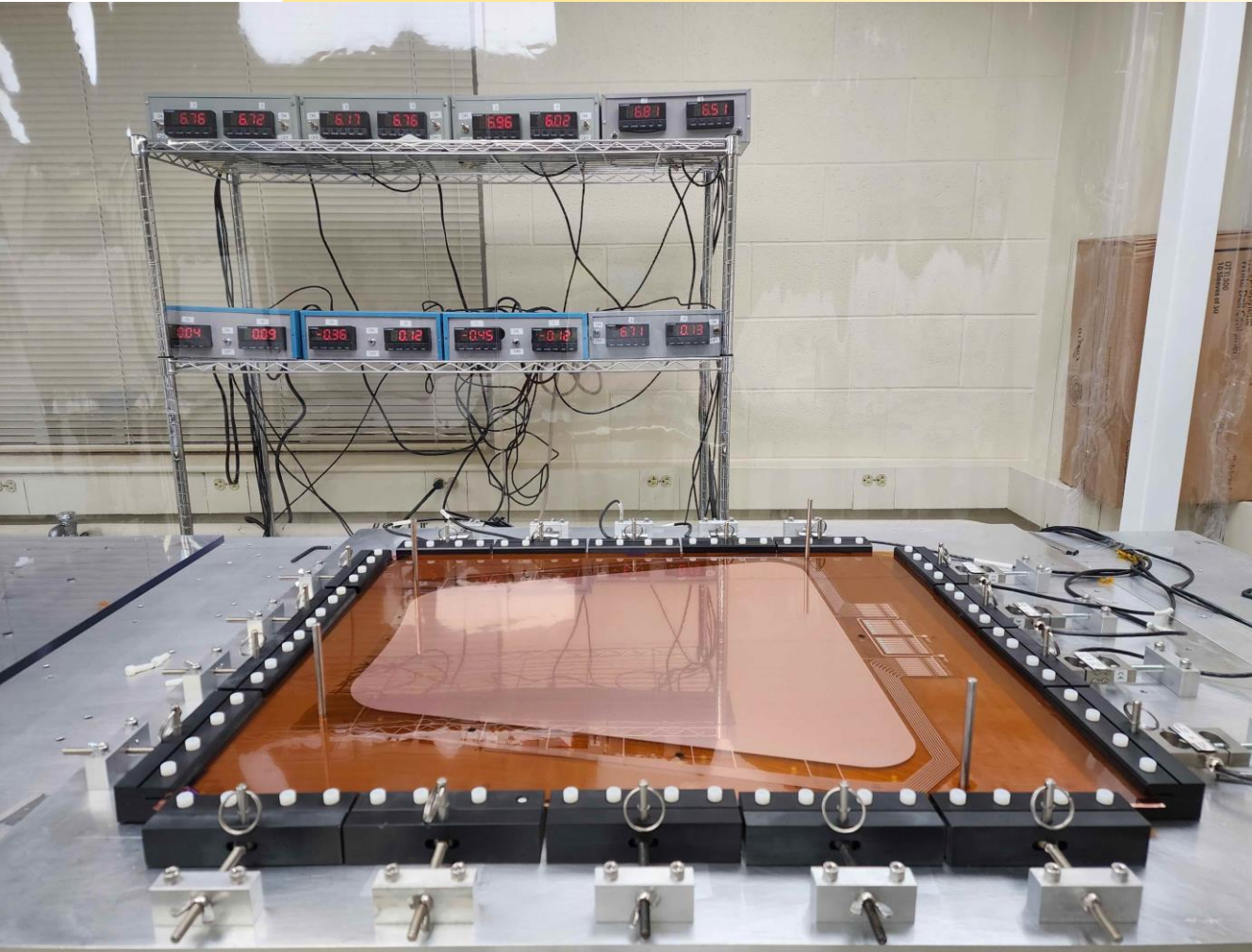

- ❑ Foil stretched to 2.5 N per cm  $\pm 10\%$
- ❑ Monitored for 24 hours till the glue dries

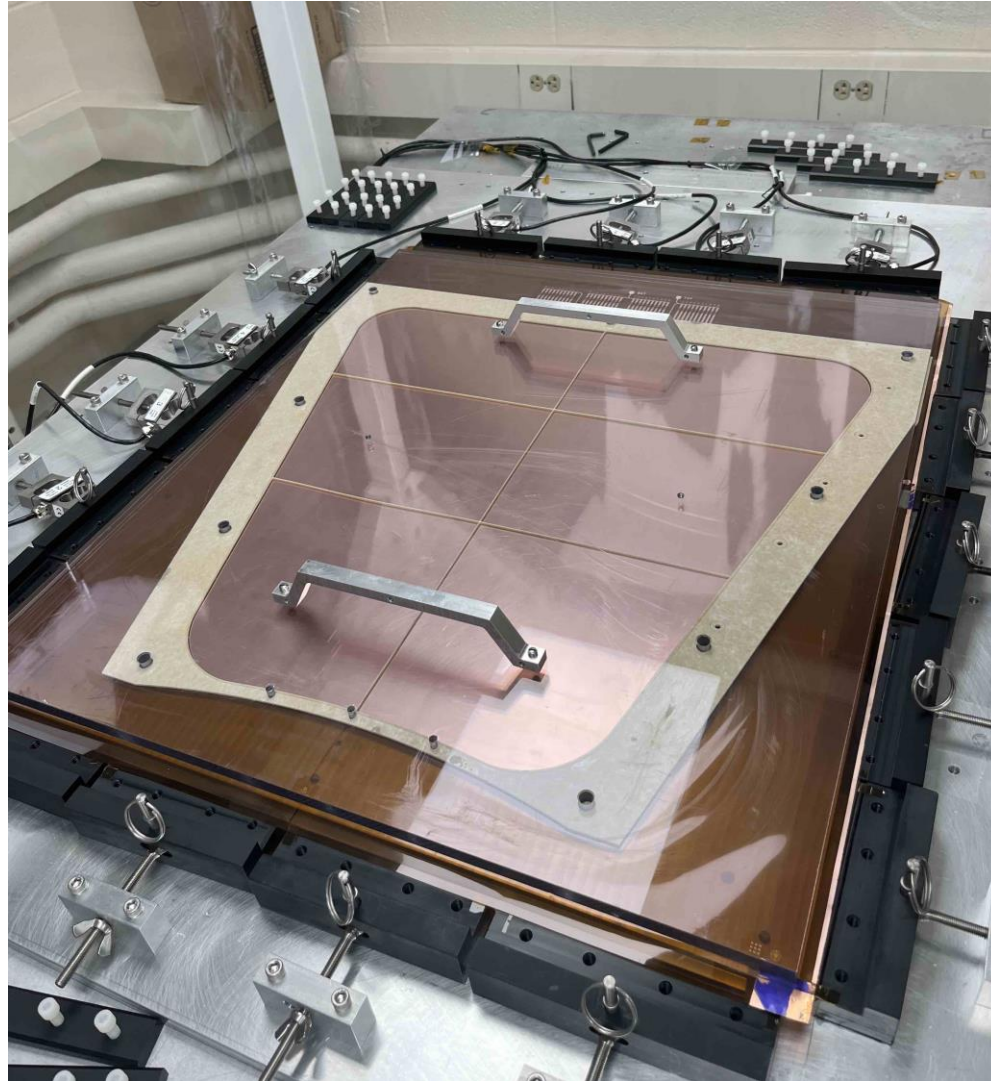

## Assembly: Gluing Framed foil to chamber

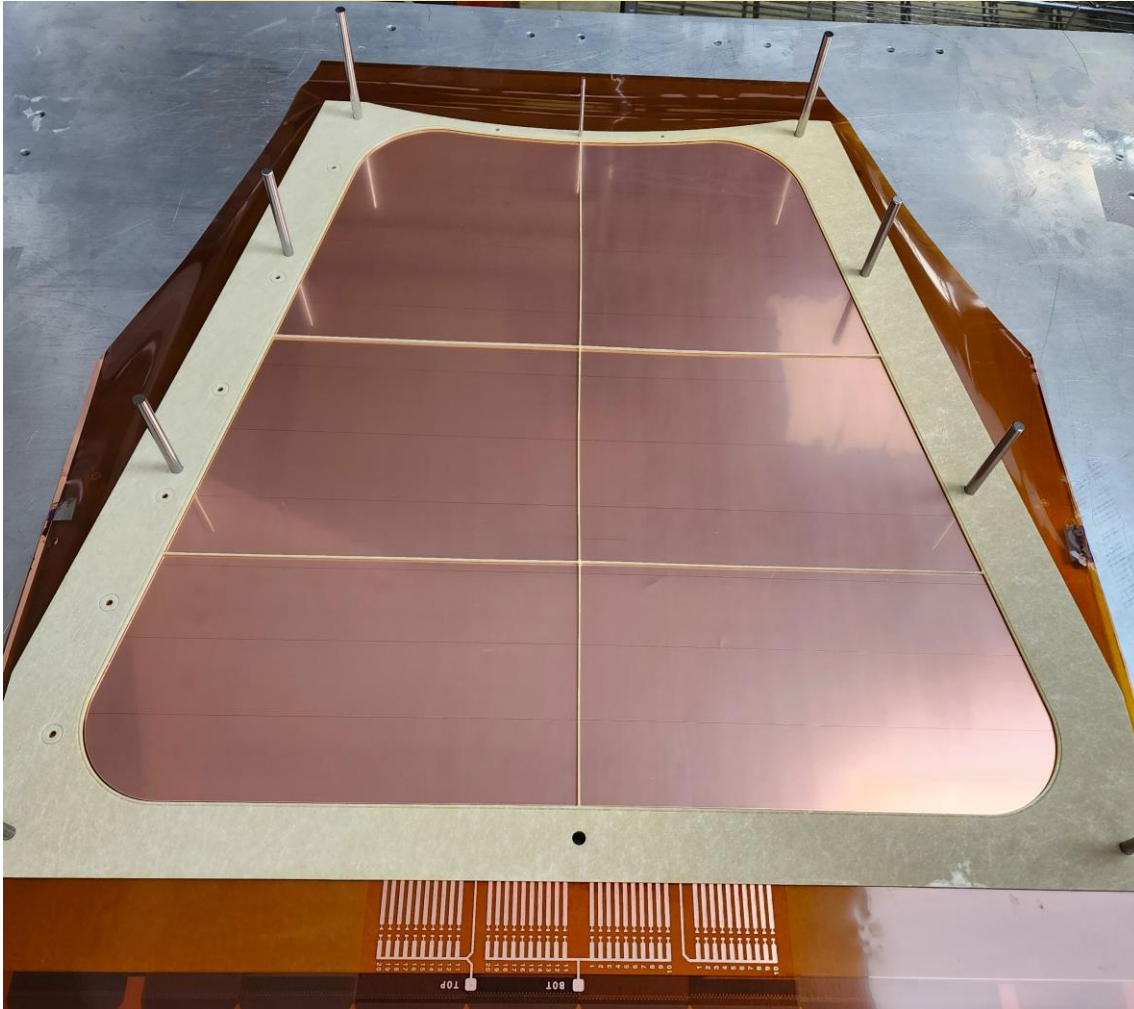

- Dowell pins used to ensure alignment to 50 micron level



Assembly: Chamber with all 3 GEM foils installed

