

Picosec uLoop Updates

Components

What's missing

- Power supply
- Rotameter valve
- Pump
- Pressure sensor
- Bosch profiles

Already delivered:

- Rotameter
- Electro-valve coil
- FBO gas fitters
- 2x Buffer volume 0.75l (cleaning)
- Flowmeter **????**
- Widgetlords devices

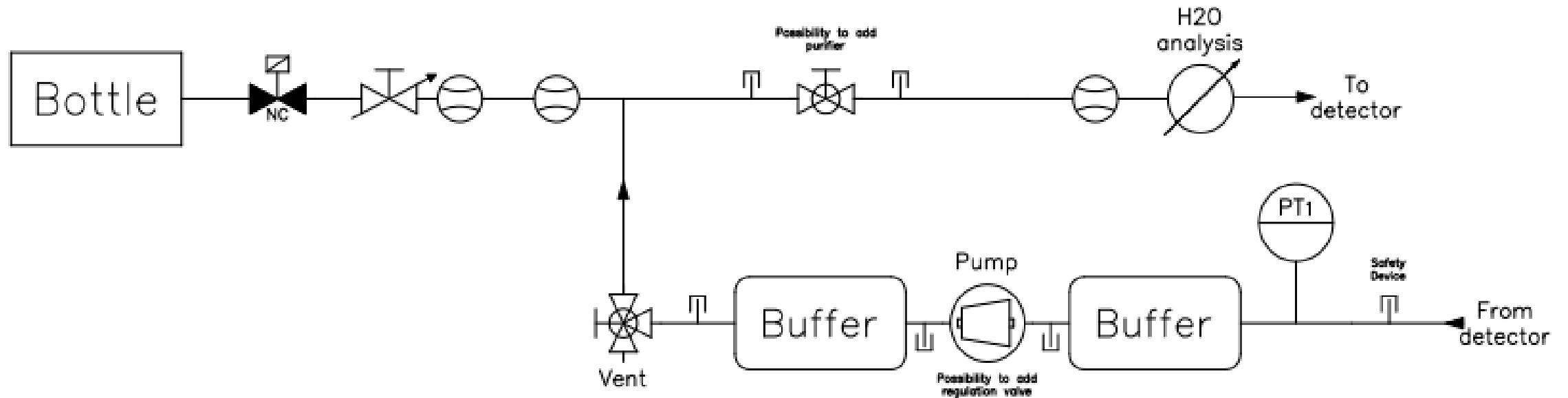

Pressure sensors' test

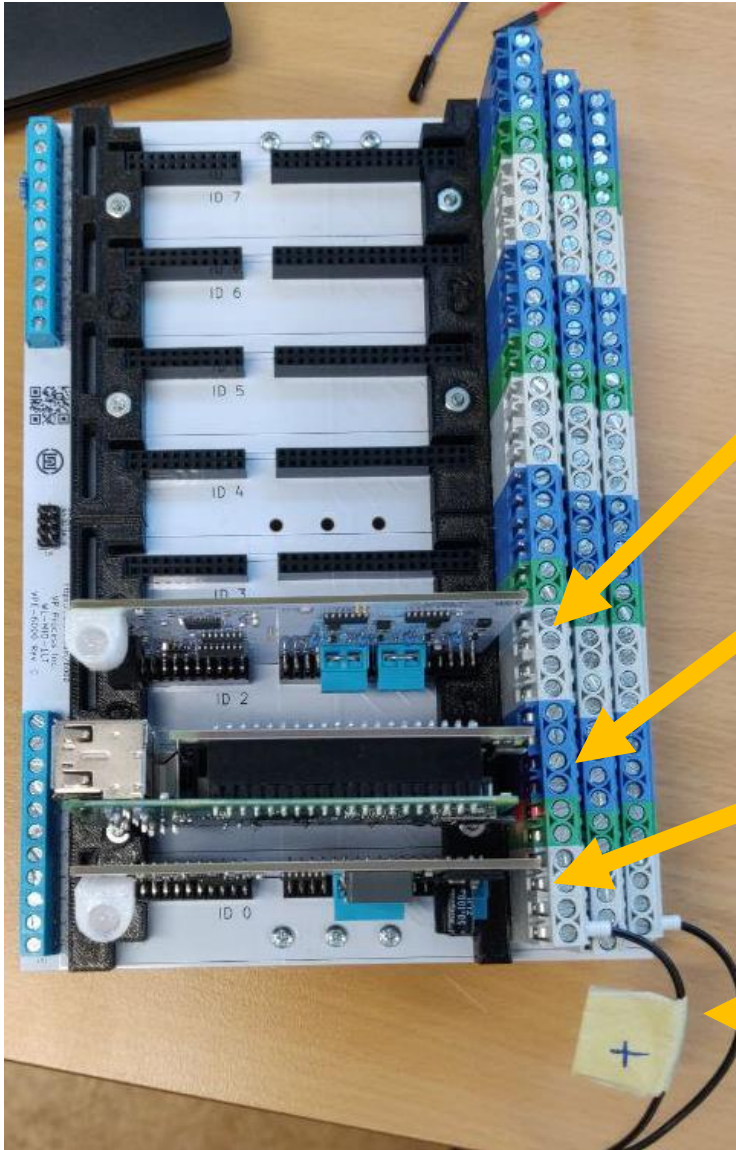

Analog input

WL MIO 6040

<https://wlmio.com/6040>

Raspberry + carrier

WL MIO 6020

<https://wlmio.com/6020>

Power supply module

WL MIO 6010

<https://wlmio.com/6010/>

External power supply

24V

Tests can start soon:

- Problem with the Widgetlords Python library needed to communicate with the devices
- Setup already made (the same as for the pumps tests)

Pressure sensors

company	sensor	datasheet
VEGA	vegabar 28	https://www.vega.com/en-ch/products/product-catalog/level/hydrostatic/vegabar-28
VEGA	vegabar 82	https://www.vega.com/en-ch/products/product-catalog/pressure/electronic-differential-pressure/vegabar-82
sensorOne	DMP331	https://www.sensorone.com/wp-content/uploads/2013/10/DMP331.pdf
sensorOne	DMK351	https://www.sensorone.com/dmk351-liquid-gas-resistant-is-low-pressure-sensor/
applied measurement s	DMK331	https://appmeas.co.uk/pdf/pressure-sensors/DMK331.pdf?d=1722349790272