



ASIC-based Fast Timing Acquisition System for the SAND Experiment

C. Maggio*, A. Di Domenico, P. Gauzzi, A. Picchi,
C. Tintori, Y. Venturini

FAST 2025 – Biodola (Portoferraio) 18-22 May 2025



CAEN
Tools for Discovery

Outline

1. SAND-ECAL PMTs: Description and FEE Requirements
2. Proposed CAEN FEE
3. The CAEN FERS-5200 System
4. A5203:
 - Description
 - Proof of Concept
 - Measurements Setup and Data Acquisition
 - Results
5. A5204:
 - Description
 - Measurements Setup and Data Acquisition
 - Results
6. Conclusions



SAND calorimeter (and magnet) from KLOE experiment at LNF

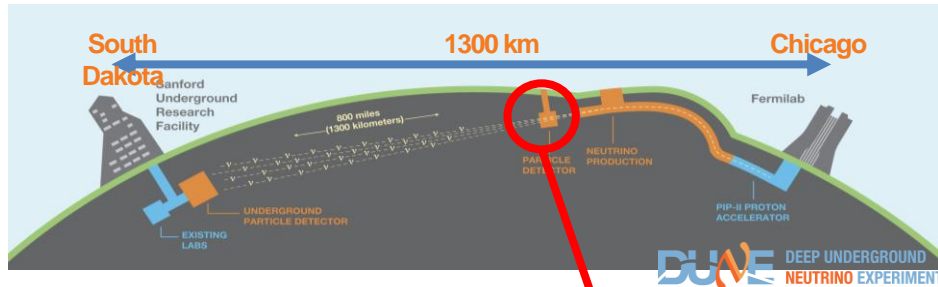

DUNE NEAR DETECTOR COMPLEX (60 m underground)

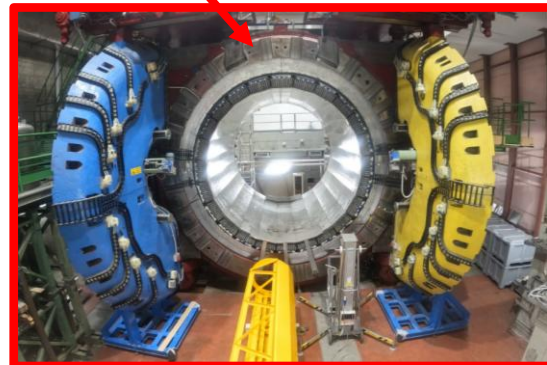
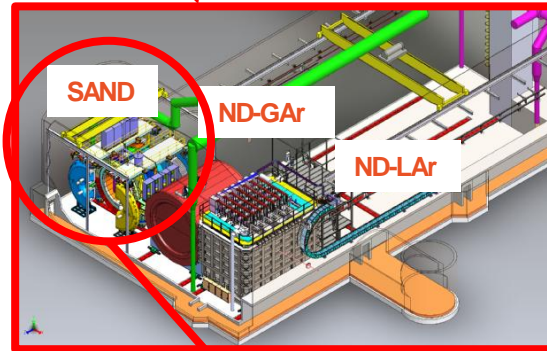

SAND - System for on-Axis Neutrino Detection

Multipurpose detector with high performance calorimeter (ECAL), light-targeted tracker (STT), LAr target (GRAIN), all in magnetic field, always on beam axis

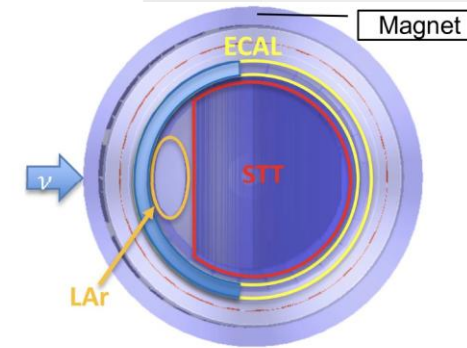

SAND - ECAL

Lead - scintillating fiber calorimeter
In total 4880 PMTs with charge and time readout

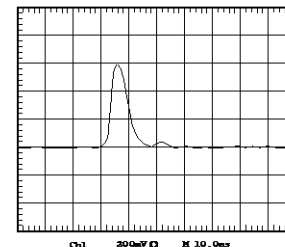

Measurement Requirements for SAND-ECAL PMTs

Hamamatsu fine-mesh PMT R5946

- signal: fast rise time ~ 2 ns
- PMT base with HV divider and signal preamp.
- typical HV for PMT 1700-1800 V $\Rightarrow G \sim 1-3 \times 10^6$
- gain preamp ~ 2.5

ECAL-PMTs FrontEnd Electronics requirements

- Energy Resolution: $\rightarrow 3-4\%$ for signals < 400 mV
 $\rightarrow 1-2\%$ for signals > 400 mV
- Time Resolution: 50 -100 ps
- Data acquisition on a wide dynamic range:
 signal from 2.5 mV to ~ 2 V amplitude
- Compact and scalable
- low-power and low-cost for multi-channel scalability



CAEN FrontEnd Electronics Options

ASIC-based front-end boards of FERS-5200 family:

1

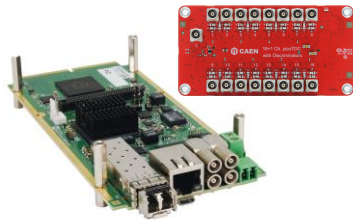

A5203+A5256:

64-channel front-end for time and ToT-reconstructed amplitude measurements

-> picoTDC (double threshold discrimination) with ToT

for all SAND-ECAL's
PMTs signals

2



A5204:

64-channel front-end for PHA and picoseconds resolution time measurements optimized for fast pulses (200 MHz counting rate)

-> Radiatoroc + picoTDC (single threshold discrimination) with ToT

for all SAND-ECAL's
PMTs signals

peak sensing ADC with slow shaper – dead time 20 μ s and good resolution

→ for rarer signals of large amplitude (to achieve better energy resolution)

- ASIC integration reduces cost per channel compared to a fully digital front-end solution based on flash ADC
- Trade-off: slightly lower flexibility vs traditional digitizers, but adequate for fixed experimental conditions

FERS-5200 Readout System

The Core Idea



Off-the-shelf front-end ASIC for scientific instrumentation

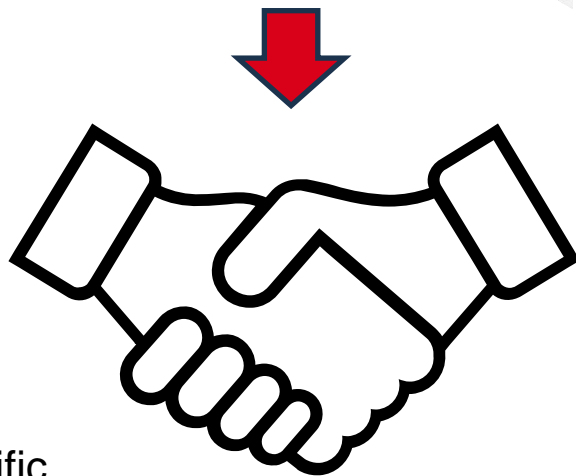

Design of Readout Electronics and Power Supply for NP and HEP

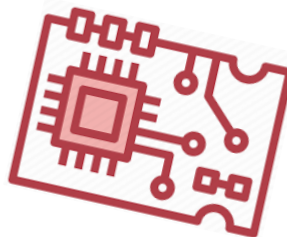
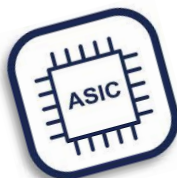

The FERS-5200 Readout System

The System

DT5215 Data Concentrator:

- 1 TDlink => up to 16 FERS
- 1 DT5215 => 128 FERS = 8k/16k ch.

Global Time



1/10 GbE
USB 3.0



10/100 MbE
USB 2.0



Desktop Evaluation Setup: Low Cost, Plug & Play

- FERSlib library (SDK coming soon)
- Janus 520X software

3.125 Gb/s TDlink

Readout
+
Slow Control
+
Synchronization

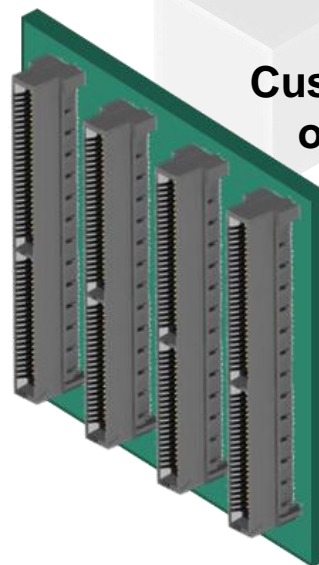
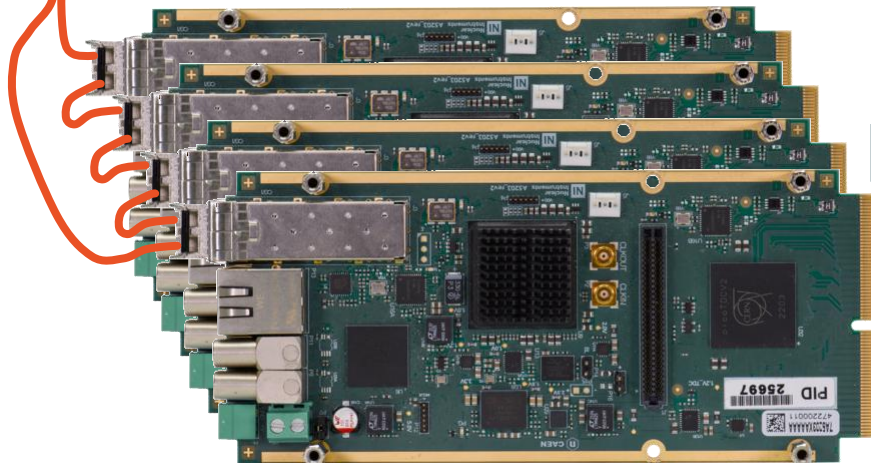

Custom Flange
or Backplane

Easy ASIC integration on FERS

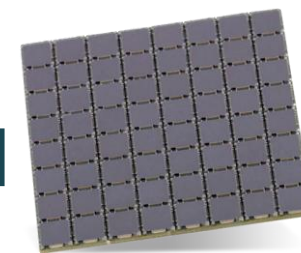

1

FERS-5200 Units A5203



128 CH CONNECTOR (A5203 ONLY)

uC

+12V DC-IN

2 In + 2 Out

Eth/USB

TDlink:
Data+Sync

Detector
inputs

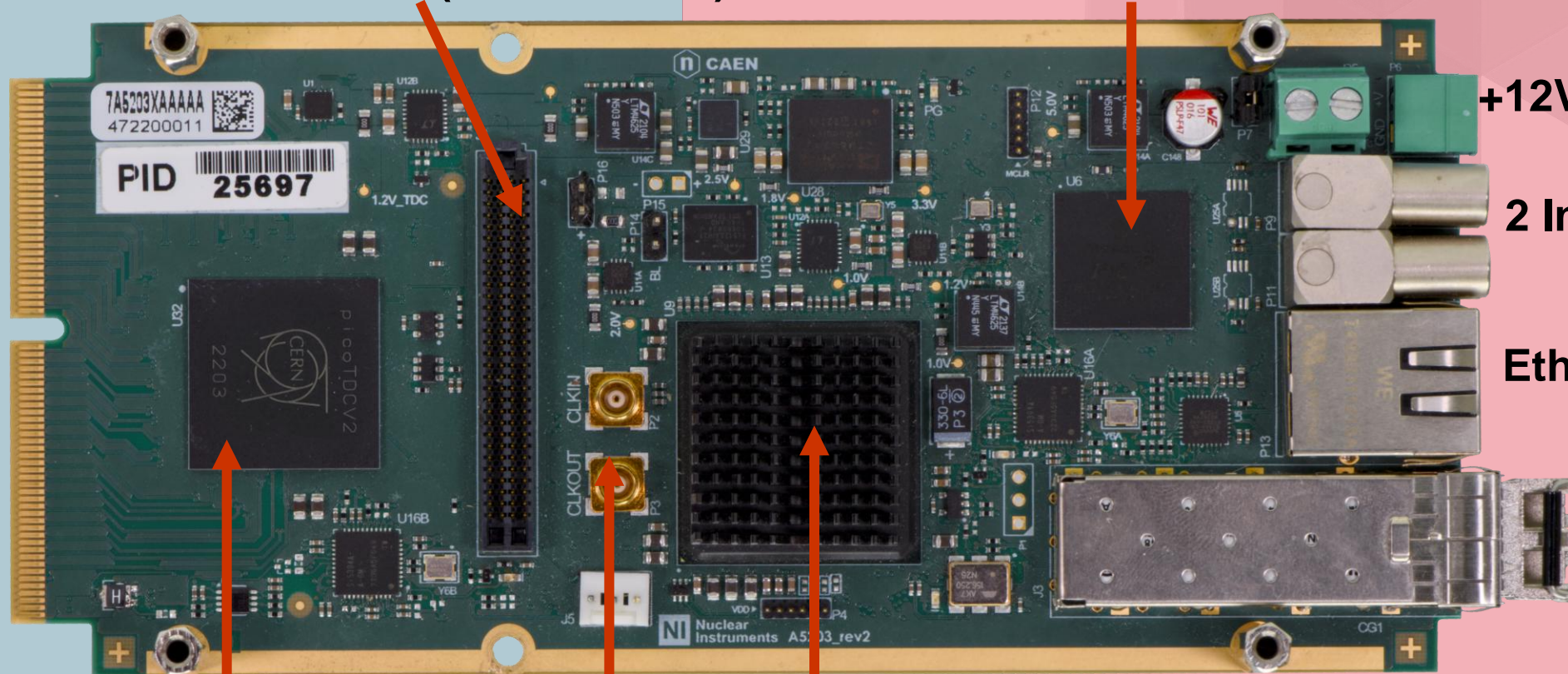

ASIC

Auxiliary
Clock

FPGA

DETECTOR SPECIFIC FRONT-END

COMMON INFRASTRUCTURE

X5203 Specifications

- **TDC:** 64/128 channels (1 picoTDC = 64 ch), LSB = 3.125 ps, dynamic range = 56 bit (extended by FPGA)
- **Inputs:** digital, LVDS → Front-End needed
- **Output Data:** Time of Arrival (ToA), Time over Threshold (ToT)
- **Data throughput:** up to ~64 Mcps/board (without filters)
- **Acquisition modes:** Common Start/Stop (Tref=Ch0), Trigger Matching, Streaming

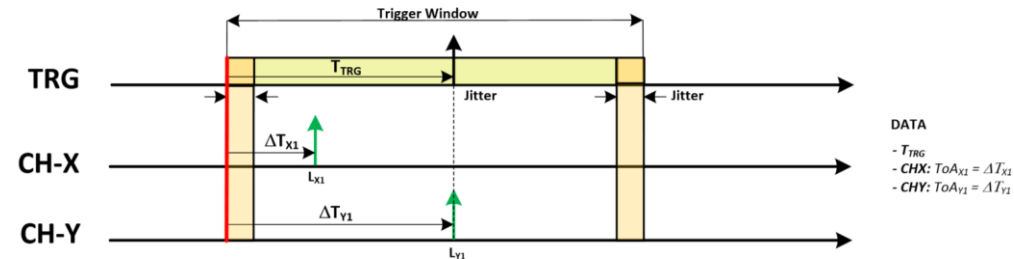
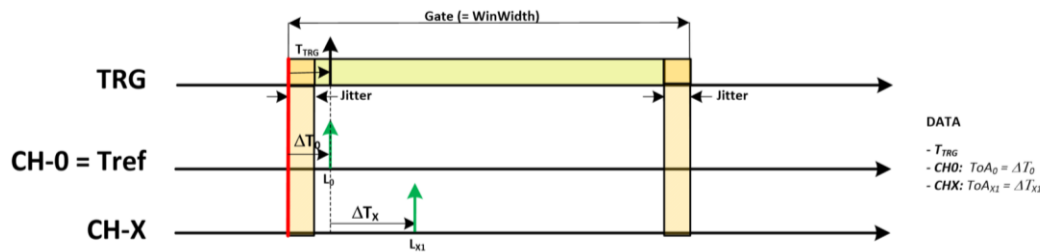

• **ΔT Resolution (*) :**

- Same board: **typ 5 ps RMS**
- Board to board: **~20 ps RMS**
synchronized by DT5215 Concentrator Board via TDlink
- Board to board: **~8 ps RMS**
synchronized by DT5215 Concentrator Board via TDlink , with auxiliary daisy chain/fan out clock cables (picoTDC clock propagation)

(*) Tested with A5256 discriminator. Pulse: 0.5 Vpp, 0.8 ns rise time

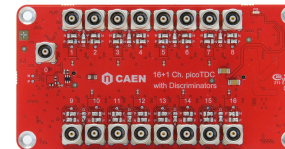

X5203 Specifications

x5203 Pros	x5203 Cons
<ul style="list-style-type: none"> • high timing resolution (~ 5 ps), high channel density, almost no dead time • provides ToA and ToT in one word 	<ul style="list-style-type: none"> • ToA affected by walk effect • No energy information (PHA) acquired - > need for a separate ADC readout chain

-> ToT-Based Analysis: Walk correction and PHA

- **ToT** can be used **to correct for time walk** => no need of Constant Fraction Discriminator in hardware
- **ToT** can be used **to reconstruct pulse amplitude**: ToT – PHA curve is not linear => need calibration (pulse shape dependent)
- **FPGA ToT filter**: rejects pulses if **ToT < LowCut** or **ToT > HighCut** (remove noise, DCR, saturation...)

Feasibility study of the ToT technique for SAND-ECAL's PMTs



ToT Analysis with A5203

Dual Threshold Calibration



Common Start Acquisition: start on Ch0 with fixed amplitude (1 V), stop on Ch1 and Ch2 (dual threshold) with variable amplitude (max = 3.85 V, rise = ~2.5 ns). Delay = 13 ns

- 1. Sweep:** acquire **ToT** and ΔT (**ToA**) at different amplitudes (from 0 to 54 dB, 3 dB step)
- 2. Fit points and build **ToT-Walk (ToA)** and **ToT-Ampl** curves**

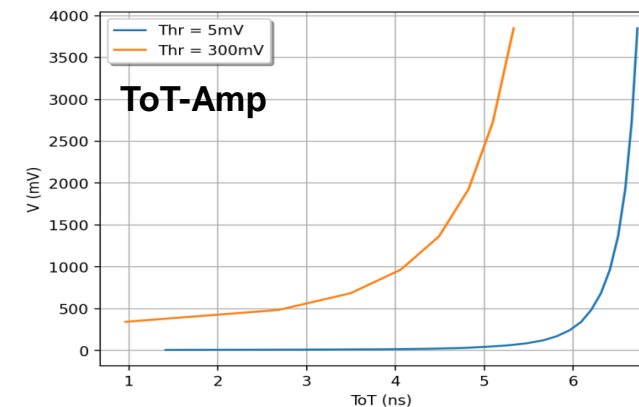
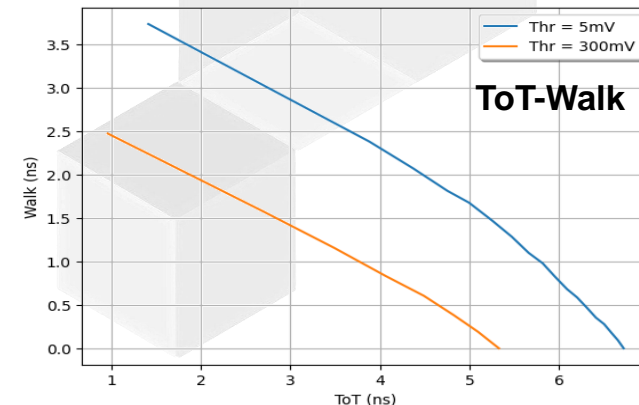
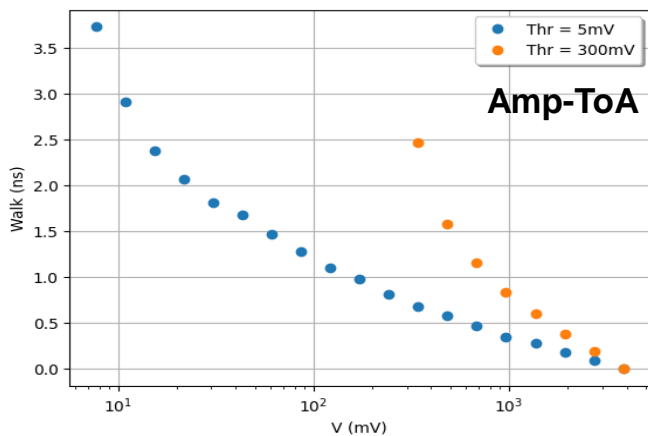
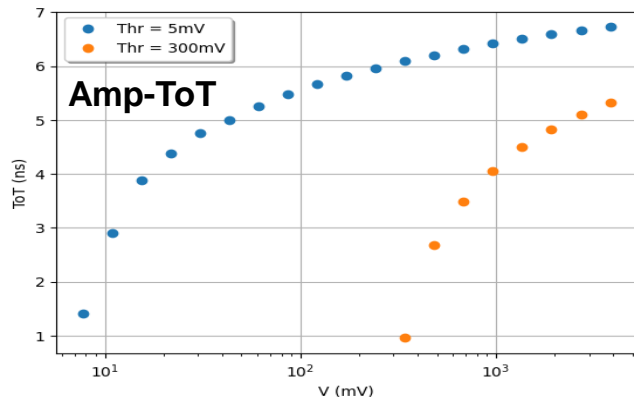

ToT Analysis with A5203

Walk Correction

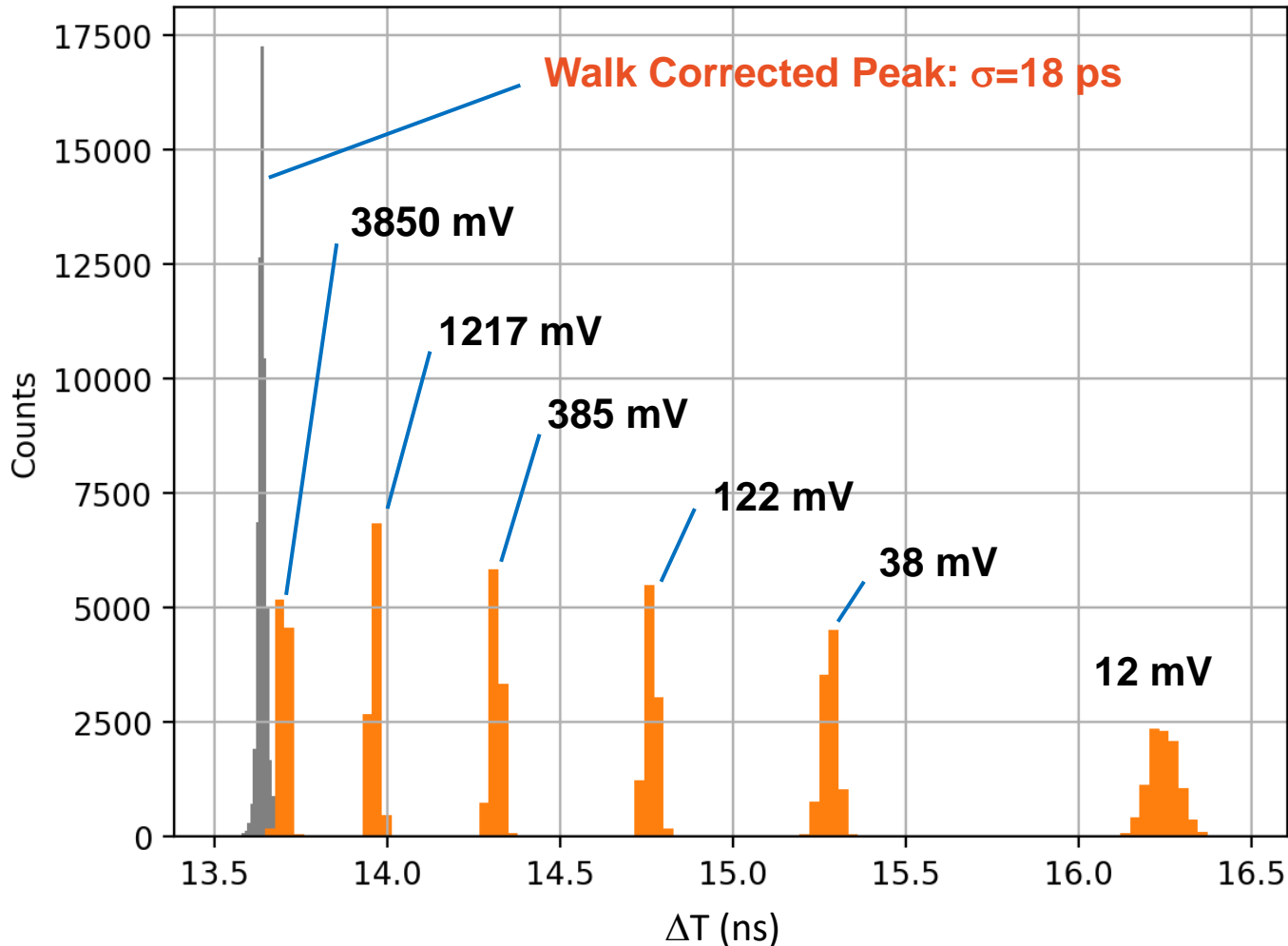

- Pulses at 6 different amplitudes over a 50 dB dynamic range
- ~2 ns spread on ΔT (ToA) caused by the walk effect: 6 separate peaks !!
 - ➔ timing resolution totally destroyed
- ΔT corrected by ToT using a 5th order polynomial fit of the **ToT-Walk** points taken at threshold = 5 mV
- Corrected ΔT histogram presents one single peak:
 - 18 ps RMS over 50 dB dynamic range**

ToT Analysis with A5203

Amplitude Reconstruction

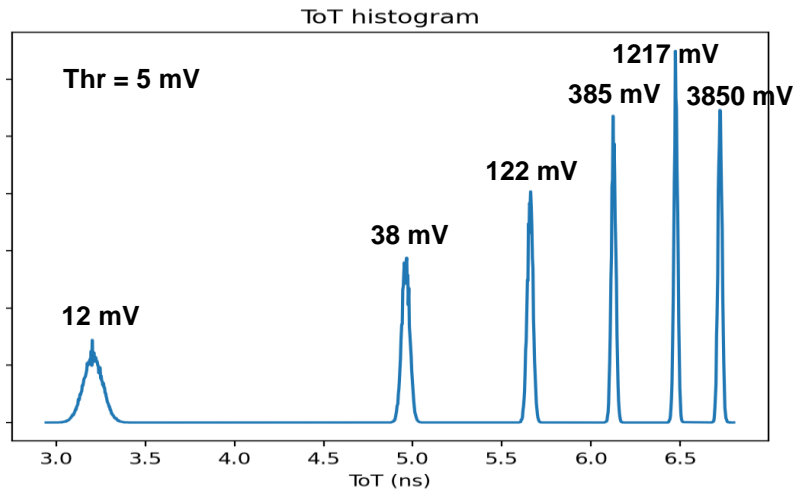

ToT-Amp

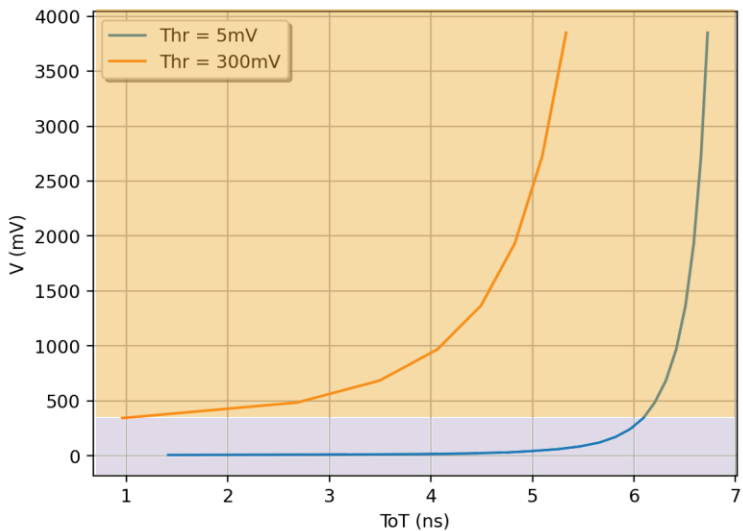

Amplitude histogram

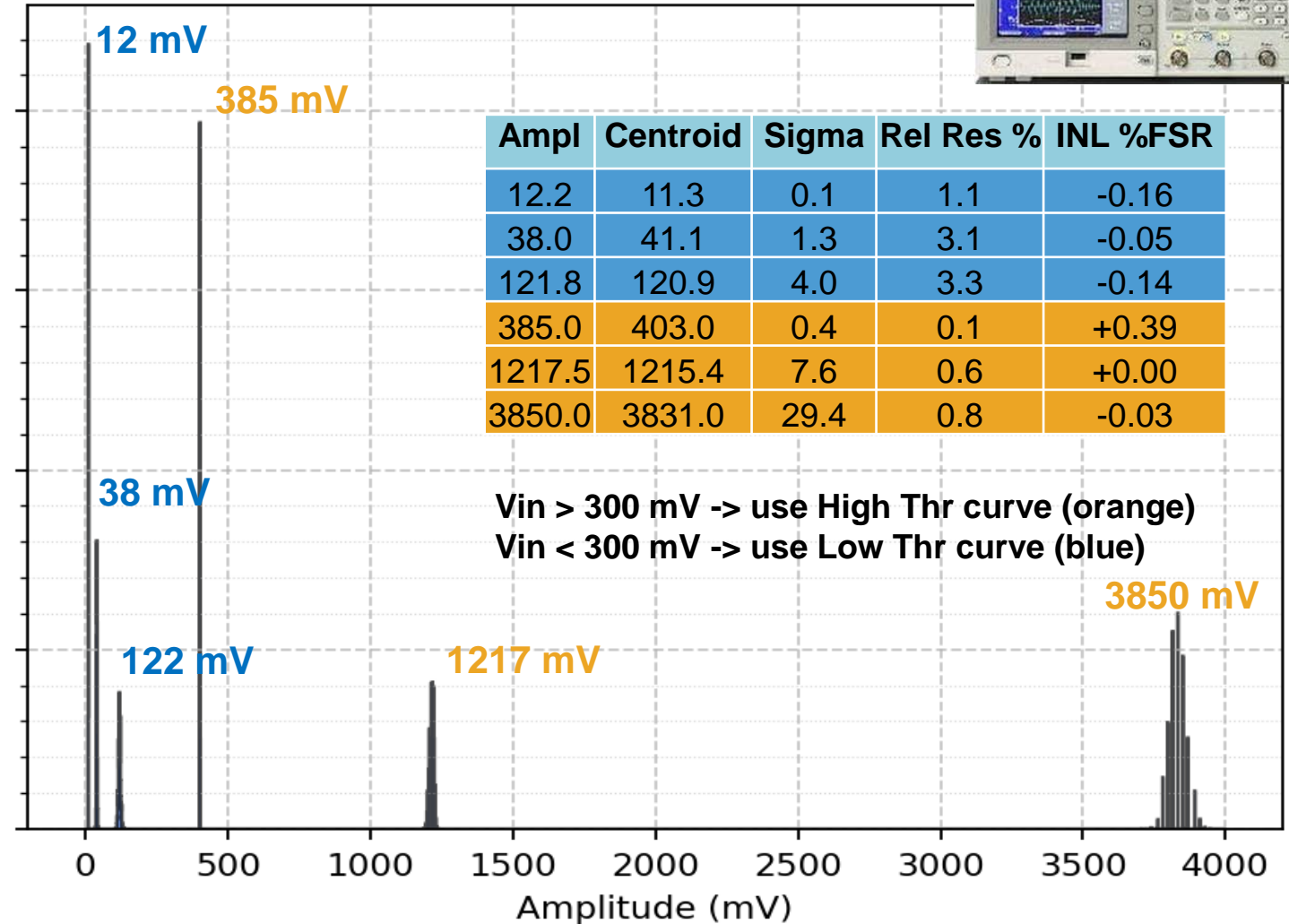

Measurements with A5203 Only

1

Read-out scheme: picoTDC + double threshold discriminator with Time over Threshold (ToT)

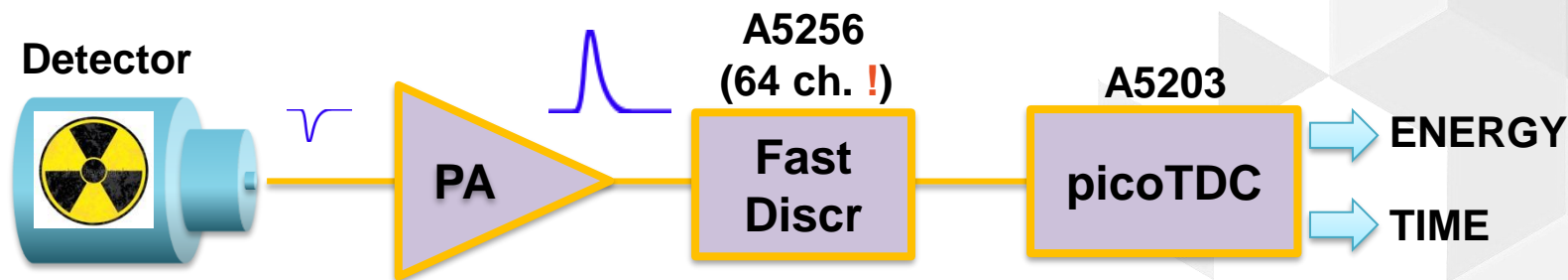

⇒ Energy by ToT with 2 thresholds not to worsen energy resolution
 ⇒ Time walk correction needed

Test Setup:

PMTs + LED Driver



⇒ Two KLOE PMTs (test + reference)
 ⇒ Led Driver CAEN SP5601 ($\lambda \sim 400$ nm) + fiber splitter

Step Attenuator



⇒ Calibrated attenuator
 ⇒ Variable amplitude

DT5203+A5256



⇒ Dual threshold
 ⇒ ToT acquisition



⇒ Walk correction
 ⇒ Energy estimation using ToT

Characterization Results #1: Time and Energy Resolutions

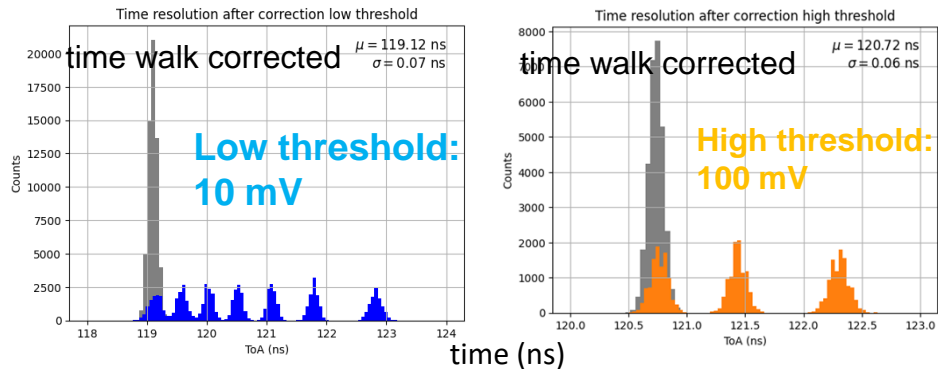

Time Resolution ~ 60 ps
(ECAL T resol. ~ $54\text{ps}/\sqrt{E(\text{GeV})} \oplus 100\text{ps}$)

Amplitude resolution obtained from ToT is compared with the intrinsic calorimeter resolution (assuming PMT gain 1 mV = 1 p.e. = 1 MeV => 1 V = 1 GeV)

To be done: optimization of the thresholds for the best performance in the whole expected dynamic range (2.5-2000 mV)

comparison with Ecal resolution ($\sigma_E/E \sim 5.7\%/\sqrt{E(\text{GeV})}$)

Amplitude reconstruction from ToT

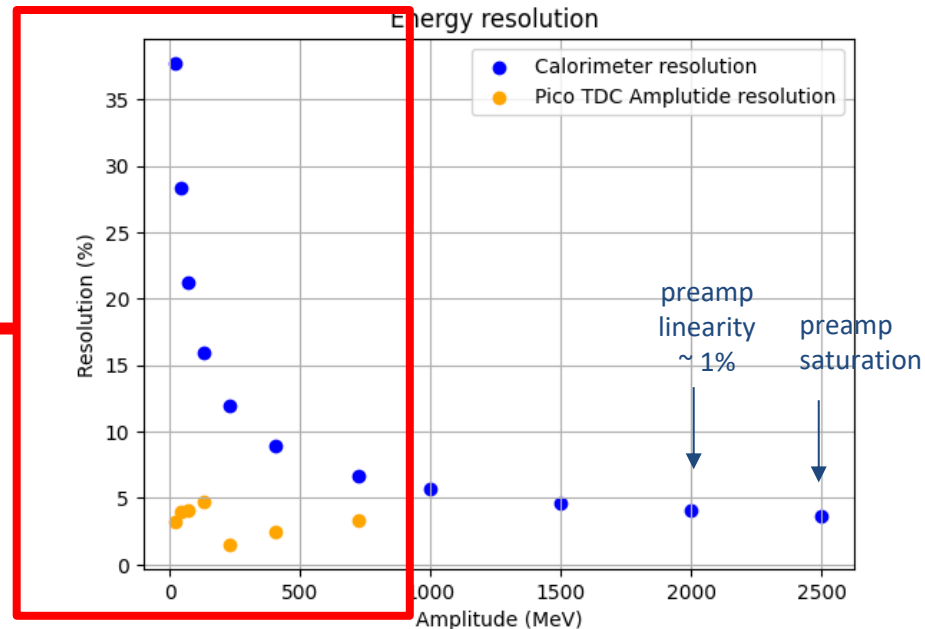
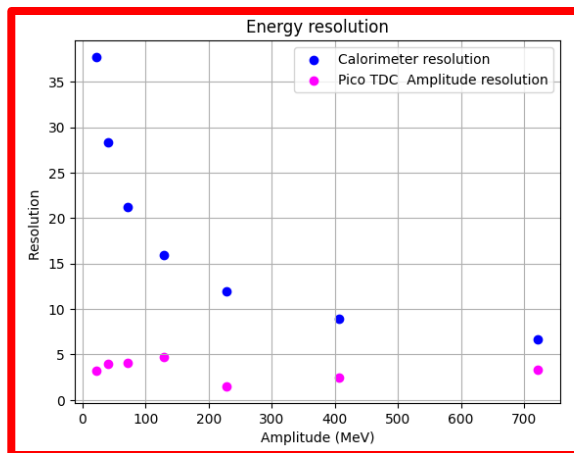
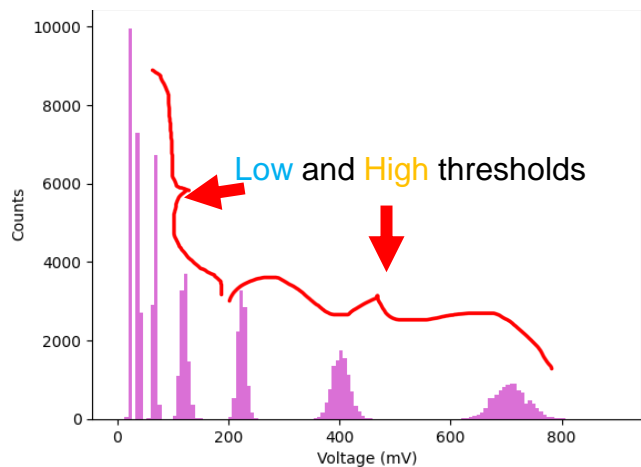

2

FERS-5200 Units A5204



HV Bias (on the bottom)

uC

+12V

2 In + 2 Out

Eth/USB

TDlink:
Data+Sync

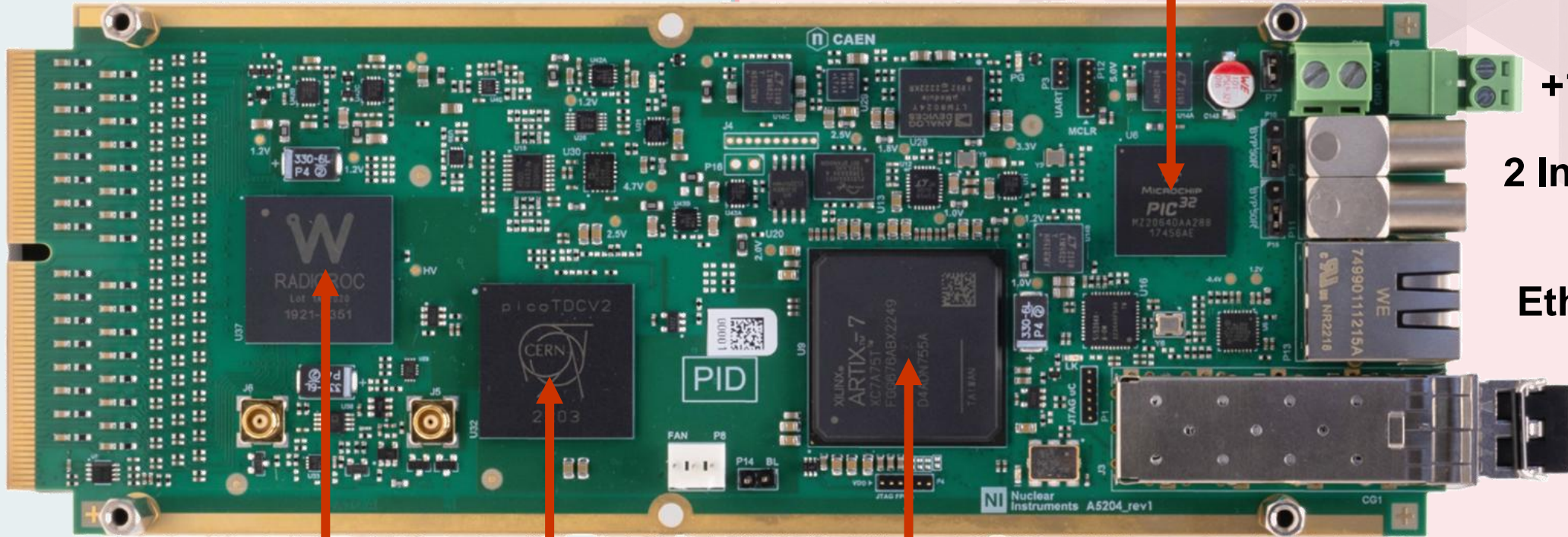

Radioroc

picoTDC

FPGA

DETECTOR SPECIFIC FRONT-END

COMMON INFRASTRUCTURE

X5204 Specifications

A5204: 64 channel SiPM Readout based on Radioroc+picoTDC

- **Inputs:** Analog inputs (charge, not voltage)
- **All-in-one readout:** Preamp + Shaper + Discr + ADC + TDC + HV Bias (20-85 V)
- **Dynamic Range:** 1 to 2500 p.e.
- **Single photon detection (threshold at 1/3 p.e.)**
- **Timing resolution:** 55 ps FWHM
- **Acquisition Modes:** Counting, Spectroscopy (PHA), Timing (ToA + ToT) , Mixed (PHA + ToA)

Measurements with A5204

2 **Read-out scheme:** Radioroc chip + PicoTDC single threshold discriminator with Time over Threshold (ToT)

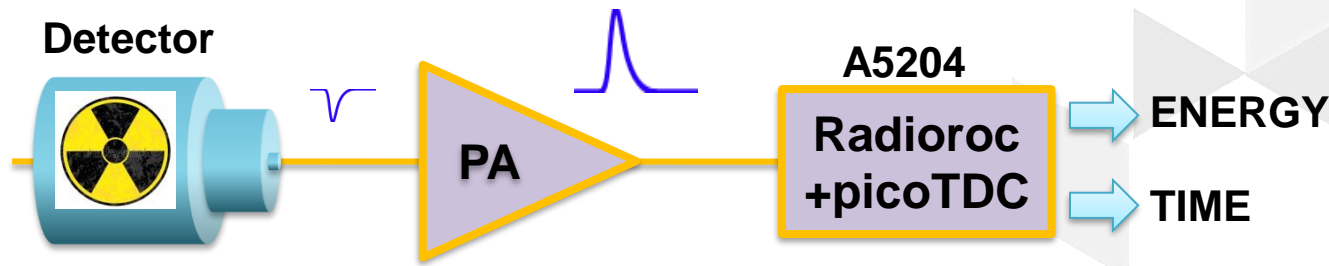

⇒ Energy & Time: Single threshold with ToT acquisition (for all signals)
 ⇒ Energy: Peak sensing ADC with slow shaper – dead time 20 μs and good resolution (for rarer signals of large amplitude)

Test Setup:



⇒ No calibration needed (done with ADC)
 ⇒ variable amplitude



⇒ Energy with ADC and by ToT with 1 threshold
 ⇒ Time with 1 threshold



⇒ Energy measurement and calibration with ADC
 ⇒ Walk correction
 ⇒ Energy estimation using ToT

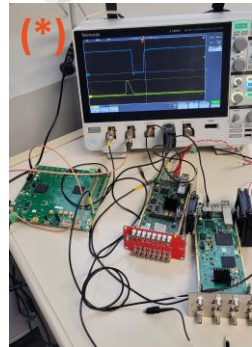

Characterization Results #2: Linearity and Energy Resolution

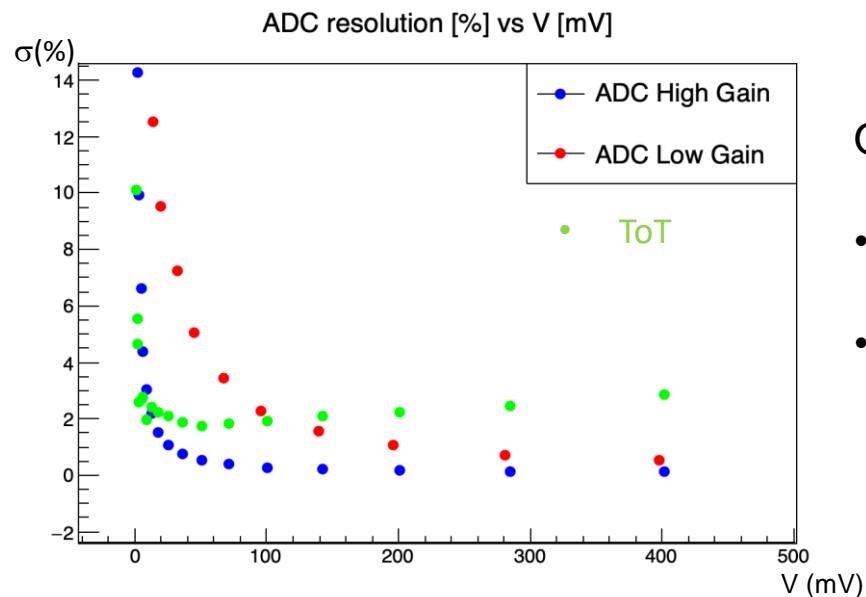
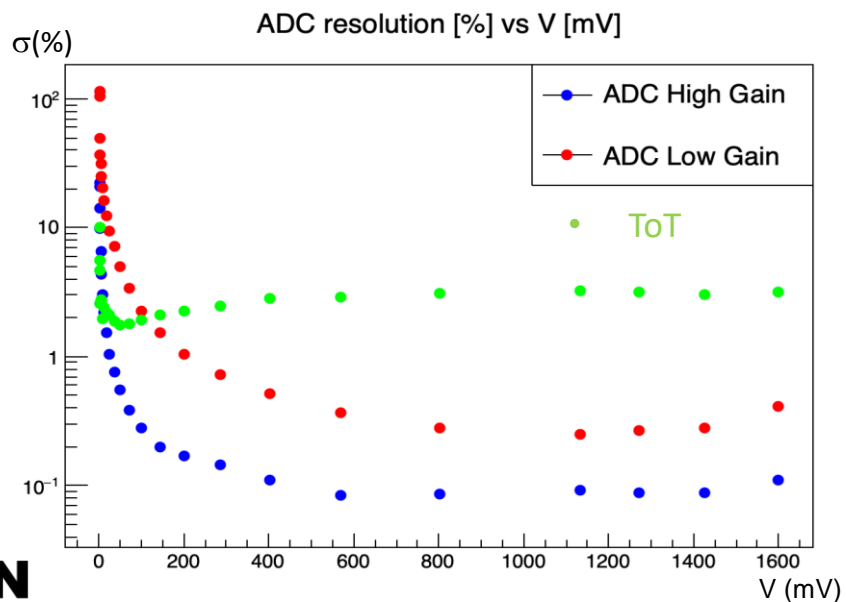
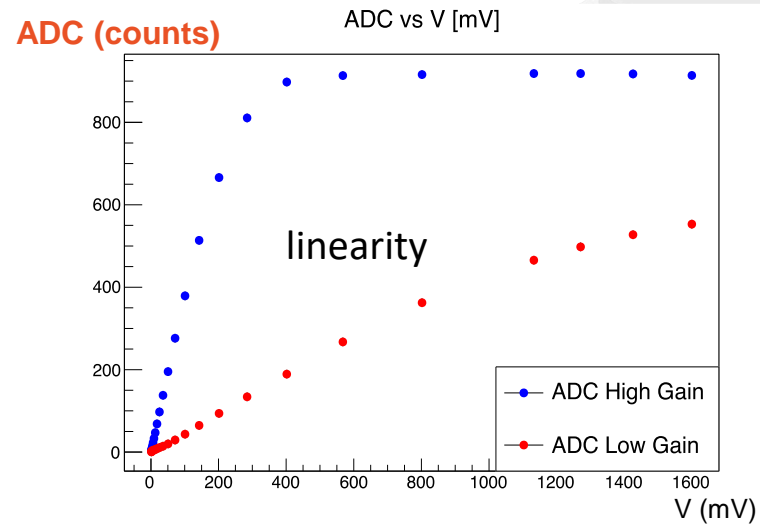
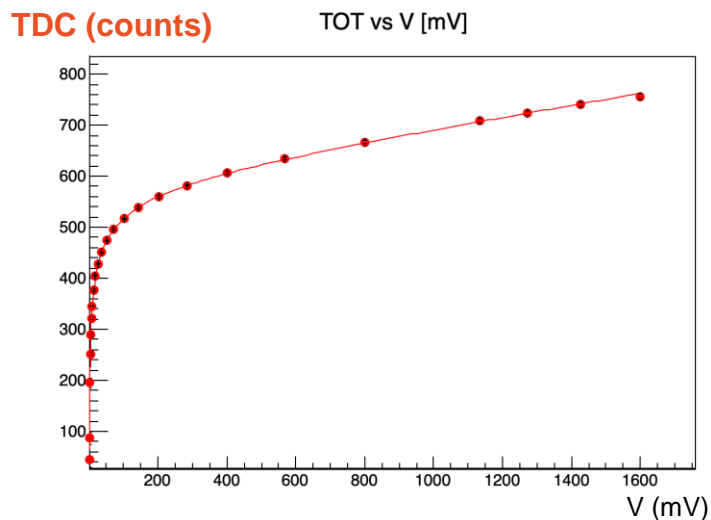

Optimal energy resolution:

- for signals < 100 mV
1-2% with fast ToT
- for signals > 100 mV
<1% with ADC (low gain)

Conclusions

SAND-ECAL PMTs FEE -> A5203 and A5204 ASIC-based boards proposed by CAEN SpA

A5203:

- Characterized up to 700 mV signal amplitudes, due to fixed pulser light intensity. Needs further characterization
- External 64 ch. double threshold discriminator needed, now only 8+1 ch.
- Double discrimination thresholds to be further optimized
- Meets time resolution requirements, meets energy resolution requirements just for low energy signals

A5204:

- Characterized Radioroc evaluation board+A5203, aim to test again with the final A5204 version
- No need for external discriminator, improved ToT linearity for high signals amplitudes (no need for double threshold)
- meets both energy and timing SAND requirements

A5204, thanks to Radioroc+ picoTDC, offers very good energy resolution at both low (ToT- reconstructed amplitude) and high energies (ADC-converted amplitude), and very good time resolution

-> **SAND-ECAL's requirements met**

-> **Future work:** measurement optimization and test under beam conditions

Thank you

Back Up Slides

Comparison Table

A5203 vs A5204

Feature	A5203 (B)	A5204
No. of Channels	64/128	64
Input signals	LVDS	Analog
Mounted Chip	picoTDC	Radoroc+picoTDC
PHA (ADC conversion)	No – pulse amplitude estimated via ToT	Yes
Energy Resolution	see slide n. 10	see slide n. 12
Time Resolution	5 ps RMS	55 ps RMS
Principal Application	Timing	PHA, Counting, Timing
Best suited for	---	SiPM

FERS-5200 Units and Adapters

A5202

A5204

Detector

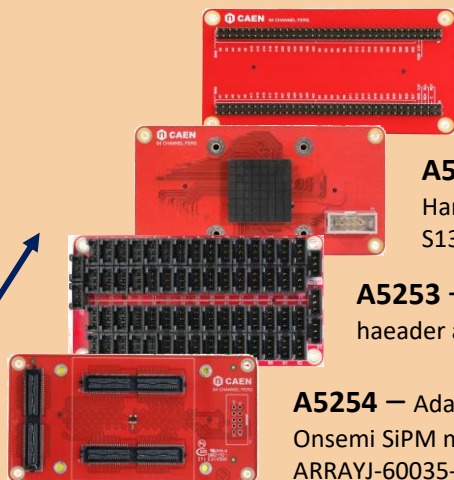
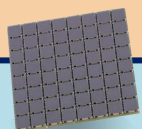

A5250 — 2.54 mm pin header adapter

A5251 — Adapter for Hamamatsu SiPM matrix S13361-3050AE-08

A5253 — 3-pin connectors haeader adapter

A5254 — Adapter for Onsemi SiPM matrices ARRAYJ-60035-64P-PCB, ARRAYC-60035-64P-PCB

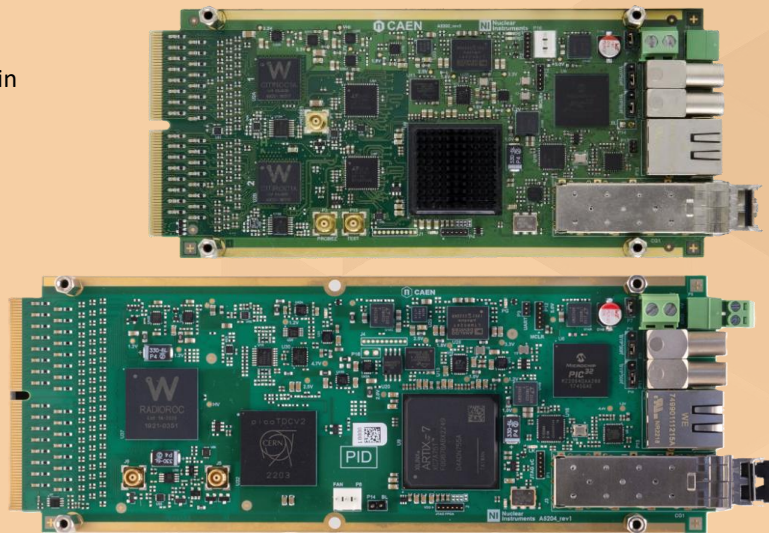

64 CHANNELS:

- ➔ MPPC bias
- ➔ Spectroscopy (PHA)
- ➔ Timing

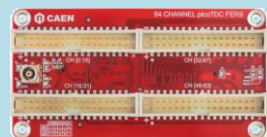

A5255 — 4x17 2.54 mm pin header connectors adapter



A5256 — 16+1 channel single threshold, 8+1 channel dual threshold edge discriminator adapter

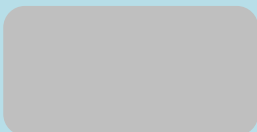

CUSTOM

A5203

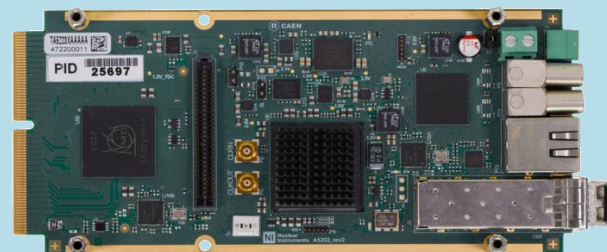

64/128 CHANNELS:

- ➔ Time Measurements (ToA & ToT)
- ➔ Amplitude Estimation

A5256 Leading Edge Discriminator

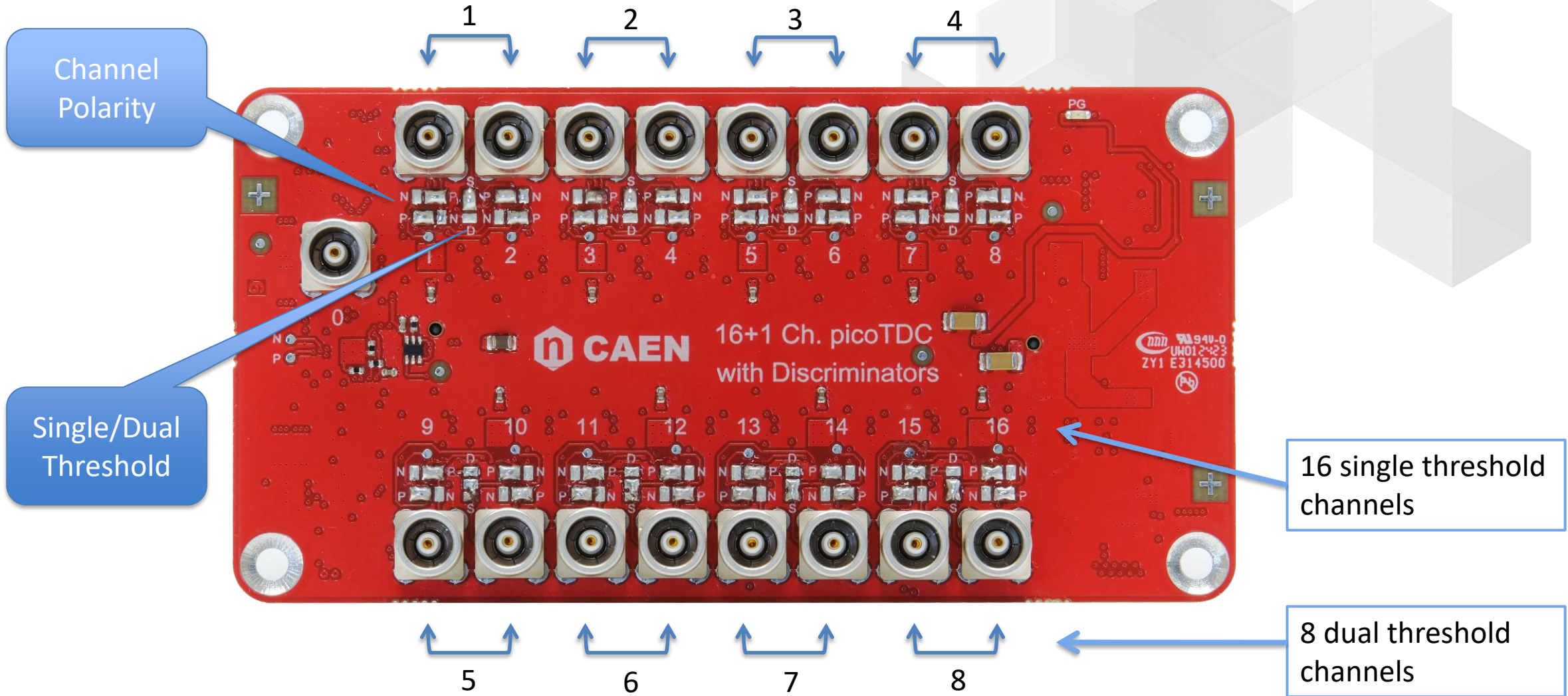

A5204 Block Diagram

