

13

Testing the Standard Model

Precision Measurements of the Z and W ; Search for the Higgs.

The ψ and Υ resonances were startling and largely unanticipated. By contrast, it was apparent far in advance that the Z would be spectacular in e^+e^- annihilation. Indeed, within the Standard Model nearly every aspect of the Z could be predicted to the extent that $\sin^2\theta_W$ was known. Despite this, the study of the Z in e^+e^- annihilation was a singular achievement in particle physics.

After initial planning as early as 1976, CERN began construction of the Large Electron Positron collider in 1983. Because ultrarelativistic electrons lose energy rapidly through synchrotron radiation, whose intensity varies as E^4/ρ , where ρ is the radius of curvature, LEP was designed with a large circumference, 26.67 km. The first collisions occurred on August 13, 1989.

In a daring move, SLAC aimed to reach the Z before LEP by colliding electron and positron beams generated with its linear accelerator. At the Stanford Linear Collider each bunch would be lost after colliding with the opposing bunch. While the Mark II detector, which had seen service at PEP, was refurbished, four new detectors – ALEPH, DELPHI, L3, and OPAL – were built at CERN.

SLC indeed got to the Z first (Ref. 13.1), but with a disappointing luminosity. In July 1989, Mark II reported for the Z a mass of 91.11 ± 0.23 GeV and a width of $1.61^{+0.60}_{-0.43}$ GeV, based on 106 events.

These results were soon surpassed by measurements at Fermilab. The original accelerator at Fermilab began operation in 1972 with an energy of 200 GeV. At the time of the discovery of the Υ in 1977, it was operating at 400 GeV. Fermilab pioneered the use of superconducting magnets, which increased the operating field to 4 T, allowing the beam energy to be doubled to 800 GeV. Following the lead of the SPS at CERN, Fermilab also constructed a ring in which antiprotons could be accumulated. The Tevatron Collider brought together protons and antiprotons inside the main ring. Through this series of improvements, the operating c.m. energy of the machine increased from about $\sqrt{s} = 20$ GeV to $\sqrt{s} = 1.6$ TeV, from which it was subsequently raised to 1.8 TeV.

The first detector at the Tevatron Collider was CDF, the Collider Detector Facility. A descendant of UA1 and UA2, CDF featured cylindrical geometry, tracking with a drift

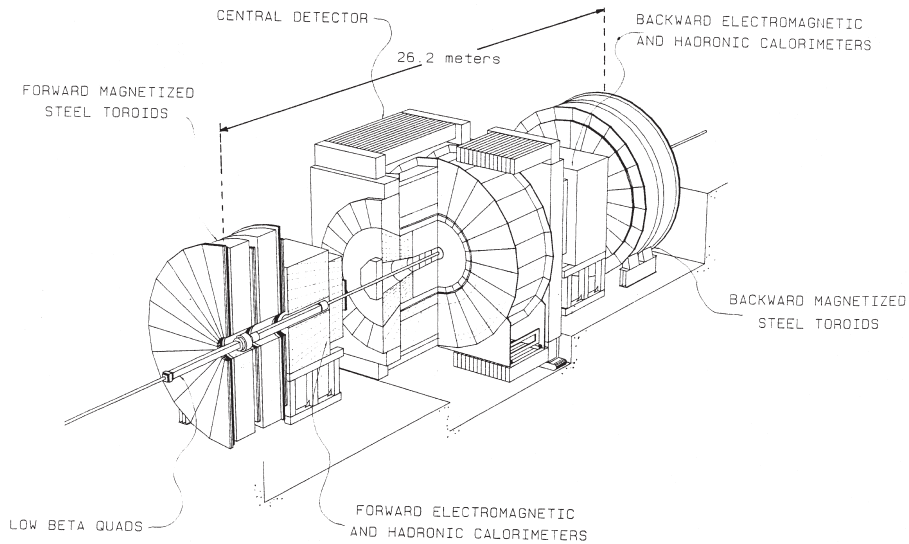

Figure 13.1. The CDF detector circa 1988. From the inside out, the major sections are the inner detector, the electromagnetic and hadronic calorimeters, and finally the magnetized steel toroids for muon identification and measurement. [Courtesy Fermilab and CDF Collaboration.]

chamber inside an axial magnetic field of 1.4 T, and both electromagnetic and hadronic calorimetry outside the magnet. The final layer provided for muon detection and measurement. During the 1988/89 run, a total of 4 pb^{-1} was accumulated.

A second detector at the Tevatron Collider, D0, was completed in 1992. It complemented CDF by optimizing calorimetry at the cost of tracking. In particular, it had no magnetic field in its tracking region. D0's advantage lay in measuring jets at high transverse momentum and in detecting missing transverse momentum, a sign of neutrinos or other non-interacting particles. The energies of electrons and muons could be measured using electromagnetic calorimetry for the former and magnetized absorbers in the outermost layers for the latter.

CDF, pursuing the hadron collider path set by UA-1 and UA-2, found a Z mass of $90.9 \pm 0.3 \pm 0.2 \text{ GeV}$ and a width $3.8 \pm 0.8 \pm 1.0 \text{ GeV}$ (Ref. 13.2) from 188 events. Back at SLAC, Mark II announced new results in October 1989, based on 480 events: $m_Z = 91.14 \pm 0.12 \text{ GeV}$, $\Gamma_Z = 2.42^{+0.45}_{-0.35} \text{ GeV}$.

The high precision measurement of initial interest was the full line shape of the Z because it would reveal the total number of light neutrinos that couple to the Z . While the apparent number was simply three – ν_e, ν_μ, ν_τ – additional generations would appear if their neutrinos were light even if their charged leptons and quarks were too heavy to be produced.

The shape of the Z resonance is determined primarily by the Breit–Wigner form discussed in Chapters 5 and 9. A relativistic version for e^+e^- annihilation through the Z to

produce the final state f at cm energy \sqrt{s} is

$$\sigma_f(s) = \frac{12\pi}{m_Z^2} \frac{\Gamma_e \Gamma_f}{\Gamma^2} \frac{s\Gamma^2}{(s - m_Z^2)^2 + s^2\Gamma^2/m_Z^2}. \quad (13.1)$$

Here Γ represents the full width of the Z including its decays to neutrinos, while Γ_f represents the partial width into some final state f and in particular Γ_e is the partial width into e^+e^- . Because the light electrons and positrons can emit photons before annihilating, there is an important radiative correction. This reduces the height at the peak and makes the shape asymmetric. The cross section is higher above the peak than below it because the higher energy electrons and positrons can lose energy and move closer to the resonance.

From the fit to the line shape, the full width Γ could be determined. The peak cross section (with radiative corrections removed) is

$$\sigma_{peak} = \frac{12\pi}{m_Z^2} \text{BR}(\ell) \text{BR}(\text{had}) \quad (13.2)$$

where $\text{BR}(\text{had})$ is the branching ratio for Z into hadrons and $\text{BR}(\ell)$ is the branching ratio for the Z into one of the three charged leptons, assuming the three to be equal. The relative frequency of the charged lepton and hadronic final states, $R_\ell = \text{BR}(\text{had})/\text{BR}(\ell)$, could be measured as well. From Γ_Z , σ_{peak} , and R_ℓ , the partial widths Γ_ℓ and $\Gamma_{hadrons}$ could be deduced. If the remainder is assumed to be due to N_ν species of neutrinos, we can write

$$\Gamma = \Gamma_{hadrons} + 3\Gamma_\ell + N_\nu\Gamma_\nu \quad (13.3)$$

where Γ_ν is the partial width of the Z into a single neutrino species. If the Standard Model prediction is used for this quantity, then the number of neutrino species can be derived. The original Mark II data gave $N_\nu = 3.8 \pm 1.4$. With 480 events, the result was $N_\nu = 2.8 \pm 0.6$, with $N_\nu = 3.9$ excluded at 95% CL.

In November 1989, the LEP experiments reported their first results, each with a few thousand events (Refs. 13.3, 13.4, 13.5, 13.6). The masses clustered near 91.1 GeV with uncertainties less than 100 MeV. The widths were all near 2.5 GeV, with uncertainties typically 150 MeV. The number of neutrino generations was found to be near three, with each experiment having an uncertainty of about 0.5. Together, the evidence was overwhelmingly for precisely three neutrino generations.

LEP studied the Z from 1989 to 1995 and tested the Standard Model in exquisite detail. The LEP detectors followed the conventional scheme of a generally cylindrical design, with charged-particle tracking close to the interaction point, followed by electromagnetic calorimetry, hadronic calorimetry, and finally by muon identification and measurement. Still, each detector had its own character. ALEPH and DELPHI both used large time projection chambers for tracking, with axial magnetic fields of 1.5 T and 1.2 T respectively. See Figure 13.2. The OPAL and L3 detectors used magnetic fields of 0.5 T. The magnet for L3 was outside the rest of the detector, providing an enormous volume over which muons could be tracked to give excellent measurements of their momenta.

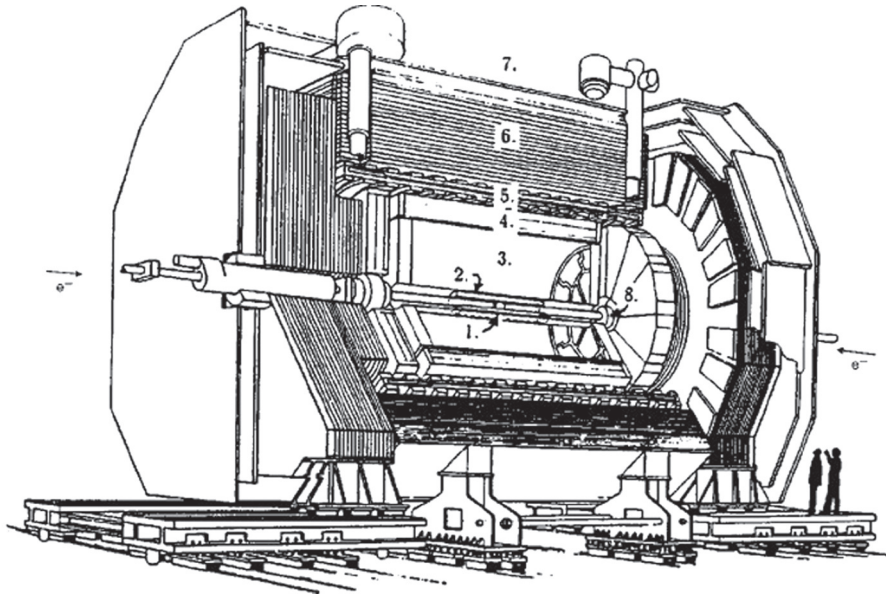

Figure 13.2. Cut-away view of the ALEPH detector at LEP showing (1) the silicon vertex detector, (2) inner trigger chamber, (3) time projection chamber, (4) electromagnetic calorimeter, (5) superconducting coil, (6) hadron calorimeter, (7) muon chambers, (8) luminosity monitors. Figure taken from M. Martinez *et al.*, *Rev. Mod. Phys.* **71**, 575 (1999).

The tremendous number of events accumulated by the LEP detectors did not guarantee high precision results. Critical to this goal were accurate measurements of the luminosity and the beam energy. Cross sections could be measured only as well as luminosities and the Z mass only as well as the beam energy. Each detector monitored the luminosity by measuring Bhabha scattering, whose cross section is well known and whose rate is so large that statistics were basically unlimited. Ultimately, with very careful measurements of the luminosity monitor geometries, uncertainties were reduced below one part in a thousand.

The beam energy at LEP was measured with extreme accuracy by using the technique of resonant depolarization. This technique, developed at Novosibirsk where it was used to measure the mass of the J/ψ to high precision, resulted in a measurement of the beam energy to approximately 1 MeV once effects from the Earth's tides and the Geneva train system were fully understood.

The thousands of events grew to 16 million, shared between the four detectors. The most precise results were ultimately obtained by combining the data from ALEPH, DELPHI, L3 and OPAL, with the results $m_Z = 91.1876 \pm 0.0021$ GeV and $\Gamma_Z = 2.4952 \pm 0.0023$ GeV. The high precision measurement of the mass of the Z is especially important because it, together with $\alpha = 1/137.03599911 \pm 0.00000046$, and $G_F = 1.16637 \pm 0.00001 \times 10^{-5}$ GeV⁻² can be taken as the three inputs that define the fundamental constants of the Standard Model. The peak cross section was found to be 41.540 ± 0.037 nb and the ratio of the hadronic to leptonic width was given by $R_\ell = 20.767 \pm 0.025$.

The Standard Model, described in Chapter 12 is a theory rather than a model in that it gives complete predictions, not just approximations. Every prediction can be expressed in terms of the three fundamental physical quantities, α , G_F , and m_Z . Other parameters of the Standard Model, like the quark and lepton masses can enter, as well. In practice, all the quark masses are small compared to the scale m_Z except for the mass of the top quark, to be discussed in Chapter 14. The mass of the Higgs boson, M_H , plays a role, too, but the dependence in radiative corrections turns out to be on $\ln M_H^2$ rather than on M_H^2 directly. Two kinds of radiative corrections turn out to be dominant: those involving m_t and the shift from using α evaluated as the static constant, $\alpha = 1/137.036\dots$, and α evaluated at the short distance given by the Compton wavelength of the Z . Because we are interested in processes at the energy scale m_Z , the expressions are simplest when written in terms of $\alpha(m_Z) \approx 1/129$.

The LEP program was to measure branching ratios, asymmetries, and polarizations, which could be compared to Standard Model results, looking for possible discrepancies that could signal new particles or forces.

The Standard Model makes very explicit predictions for the branching ratios of the Z . Using the relations given in Chapter 12, we find that for a decay to a left-handed fermion (and a right-handed antifermion),

$$\Gamma(Z \rightarrow f_L \bar{f}_R) = \frac{\sqrt{2} G_F m_Z^3}{6\pi} (T_3 - Q \sin^2 \theta_W)^2 \quad (13.4)$$

where Q is the charge of the fermion, T_3 is its third component of weak isospin ($1/2$ for u , c , $-1/2$ for d , s , and b) and θ_W is the weak mixing angle. If the fermion is a quark rather than a lepton, we must multiply by a color factor of three. For right-handed fermions (and left-handed antifermions), we have similarly,

$$\Gamma(Z \rightarrow f_R \bar{f}_L) = \frac{\sqrt{2} G_F m_Z^3}{6\pi} (Q \sin^2 \theta_W)^2. \quad (13.5)$$

There is a correction from QCD for the width to quark pairs, which in lowest order is a factor $1 + \frac{\alpha_s}{\pi} \approx 1.03$.

The angular dependence of the production of the various fermion pairs is governed by the simple expressions analogous to those given in Chapter 8, which reflect angular momentum conservation. Because the Z has only vector and axial vector couplings to fermions a left-handed electron can annihilate only a right-handed positron. If the electron's direction is the z -axis, the pair annihilates into a Z with $J_z = -1$. If the final fermion f is left-handed, then the antifermion is right-handed and angular momentum conservation prevents the fermion from coming out in the negative z direction. Thus we find

$$\frac{d\sigma}{d\Omega}(e^- e_R^+ \rightarrow Z \rightarrow f_L \bar{f}_R) \propto (1 + \cos \theta)^2 \quad (13.6)$$

$$\frac{d\sigma}{d\Omega}(e^- e_R^+ \rightarrow Z \rightarrow f_R \bar{f}_L) \propto (1 - \cos \theta)^2 \quad (13.7)$$

$$\frac{d\sigma}{d\Omega}(e_R^- e_L^+ \rightarrow Z \rightarrow f_L \bar{f}_R) \propto (1 - \cos \theta)^2 \quad (13.8)$$

$$\frac{d\sigma}{d\Omega}(e_R^- e_L^+ \rightarrow Z \rightarrow f_R \bar{f}_L) \propto (1 + \cos\theta)^2 \quad (13.9)$$

Since the cross sections are proportional to $\Gamma_e \Gamma_f$ we have for unpolarized scattering

$$\begin{aligned} \frac{d\sigma}{d\Omega}(e^- e^+ \rightarrow Z \rightarrow f \bar{f}) \\ \propto [\Gamma_{e_L} + \Gamma_{e_R}][\Gamma_{f_L} + \Gamma_{f_R}](1 + \cos^2\theta) + 2[\Gamma_{e_L} - \Gamma_{e_R}][\Gamma_{f_L} - \Gamma_{f_R}]\cos\theta. \end{aligned} \quad (13.10)$$

An asymmetry can be formed by comparing the number of events F in which the fermion f goes forward, that is, into the hemisphere in the electron's direction to the number B in which f goes into the backward hemisphere. We find

$$A_{FB}^f \equiv \frac{F - B}{F + B} = \frac{3[\Gamma_{e_L} - \Gamma_{e_R}][\Gamma_{f_L} - \Gamma_{f_R}]}{4[\Gamma_{e_L} + \Gamma_{e_R}][\Gamma_{f_L} + \Gamma_{f_R}]} \equiv \frac{3}{4} \mathcal{A}_e \mathcal{A}_f \quad (13.11)$$

where $\mathcal{A}_f = (\Gamma_{f_L} - \Gamma_{f_R})/(\Gamma_{f_L} + \Gamma_{f_R})$. The measurement of the forward-backward asymmetry in $e^+ e^- \rightarrow Z \rightarrow \mu^+ \mu^-$, for example, provides a clean measurement of $\sin^2 \theta_W$ since we have

$$\mathcal{A}_\ell = \frac{1 - 4 \sin^2 \theta_W}{(1 - 2 \sin^2 \theta_W)^2 + 4 \sin^4 \theta_W}. \quad (13.12)$$

The combined LEP result was $A_{FB}^\ell = 0.0169 \pm 0.0013$.

The SLC's luminosity improved over the years, though it never rivaled that at LEP. Still SLC did have a capability that made it competitive for this class of measurements: beam polarization. Using the same technique that was used in the measurement of the left-right asymmetry in deep inelastic scattering of electrons off protons discussed in Chapter 12, left-handed and right-handed electrons were injected into the SLAC linac. It was not necessary to polarize the positrons since the coupling only allows annihilation of pairs with parallel spins.

An asymmetry can be formed for left-handed and right-handed electrons producing any final state, f . That asymmetry is simply equal to \mathcal{A}_e . If the degree of polarization of the beams is P , then \mathcal{A}_e is simply given by $1/P$ times the observed asymmetry. Ultimately, an electron polarization of about 80% was achieved. The careful measurement of the polarization by scattering a polarized beam from the polarized electron beam was essential to the measurement. The result reported in 1997 by the SLD Collaboration (Ref. 13.7) was $\mathcal{A}_e = 0.151 \pm 0.011$, equivalent to $A_{FB}^\ell = 0.0171 \pm 0.0025$. The final analysis of the full data set gave an improved result, $\mathcal{A}_e = 0.1516 \pm 0.0021$, equivalent to $A_{FB}^\ell = 0.0171 \pm 0.0005$, consistent with the LEP result, but more precise.

With the measurement of the Z mass pinned down, the third fundamental parameter of the Standard Model, the measurement of the W mass became a critical test. The basic prediction for the W mass is

$$m_W^2 = \frac{\pi \alpha}{\sqrt{2} G_F \sin^2 \theta_W} \quad (13.13)$$

where $\sin^2 \theta_W$ itself depends on m_W :

$$\sin^2 \theta_W = 1 - \frac{m_W^2}{m_Z^2}. \quad (13.14)$$

This is modified by radiative corrections. However, the dominant correction is simply to replace the usual fine structure constant $\alpha(0)$ by $\alpha(m_Z^2)$. Additional corrections depend on m_t^2 and $\ln(m_H/m_Z)$. See Problem 13.5. Thus a precision measurement of the W mass could predict the mass of the top quark, with only a weak dependence on the unknown mass of the Higgs boson.

While e^+e^- annihilation provided an unbeatable method for studying the Z , LEP was not suited for studying the W . The original measurements of the W mass by UA-1 and UA-2 had uncertainties of several GeV. In 1990, CDF reported on 1722 events combining results from the $W \rightarrow e\nu$ and $W \rightarrow \mu\nu$ channels. CDF found $m_W = 79.91 \pm 0.39$ GeV. By 1992, UA-2 had reduced the error by accumulating more than 2000 events of the decay $W \rightarrow e\nu$. For the ratio m_W/m_Z they found $0.8813 \pm 0.0036 \pm 0.0019$. The ratio could be determined more precisely than either value separately because some of the uncertainties were common to the two measurements. At the time, the mass of the Z had already been measured to ± 20 MeV at LEP, giving a combined result of $m_W = 80.35 \pm 0.33(\text{stat.}) \pm 0.017(\text{syst.})$ GeV.

In Run I at the Fermilab Tevatron Collider, from 1992 to 1995, CDF and D0 both accumulated large numbers of W 's and Z 's. The errors for each experiment were reduced to near 100 MeV, with a combined result of 80.450 ± 0.063 GeV, reported in 1999.

An entirely new approach to measuring the W mass became possible once the energy at LEP was increased above the WW threshold in June, 1996. The W pair cross section rises gradually rather than abruptly because the substantial width of the W makes it possible to produce one real and one virtual W . While one can measure the W mass through careful determination of the threshold rise, in fact the method found more effective at LEP-II was to reconstruct the mass from final states in $W \rightarrow q\bar{q}$, $W \rightarrow q\bar{q}$ and $W \rightarrow q\bar{q}$, $W \rightarrow \ell\nu$ events.

In 1997, more than 50 pb^{-1} of data were accumulated near $\sqrt{s} = 180$ GeV. The mass of the W could be determined with a statistical uncertainty of about 130 MeV by each experiment. Combining the experiments gave $80.38 \pm 0.07 \pm 0.03 \pm 0.02$ GeV, with the uncertainties arising from the experiment itself, from theoretical issues, and from the LEP beam energy. Further measurements were made as the c.m. energy was increased up to 206 GeV. The combined LEP result was $m_W = 80.376 \pm 0.033$ GeV. An upgraded CDF detector, running at the Tevatron Collider's Run II, remeasured the W with greatly increased

statistics and found a result in 2007 completely compatible with CERN's, $m_W = 80.413 \pm 0.048$ GeV.

Even before the discovery of the top quark in 1995, the W mass measurements were accurate enough to predict m_t to be around 180 GeV, assuming the Higgs mass was in the range of 100–1000 GeV.

The Higgs boson is the least constrained part of the Standard Model. Indeed, there is no a priori limit on its mass. If the mass is sufficiently large, more than say 1.5 TeV, the width of the Higgs boson becomes comparable to its mass and it is hard to justify calling it a particle at all. On the other hand, there is no reason to suppose that there is just a single Higgs boson. Indeed some models, like supersymmetry, require that there be more than one neutral Higgs boson. Because the Higgs boson couples feebly to light particles (that is why they are light!), it is best sought in conjunction with heavy particles. LEP II offered an ideal approach: $e^+e^- \rightarrow ZH$. The electron–positron pair annihilate into a virtual Z , which then decays to a real Z and the Higgs boson. In this way, a Higgs boson could be found up to very near the kinematic limit, $m_H = \sqrt{s} - m_Z$.

The Higgs boson couples to fermion pairs according to their masses, making $H \rightarrow b\bar{b}$ and $H \rightarrow \tau^+\tau^-$ the best targets. The accompanying Z can be detected in any of its decay channels. One vexing background comes from the ZZ final state, when one Z decays to $b\bar{b}$. With data taken at a center-of-mass energy of 189 GeV, three of the LEP experiments were able to set lower limits of about 95 GeV on a Standard Model Higgs boson, while the limit from ALEPH, the remaining experiment, was about 90 GeV.

Still there was more to be wrung out of LEP. Between 1995 and 1999 one after another upgrade was carried out to raise the energy higher and higher, opening each time a new window in which the Higgs boson might appear. The enormous effort this entailed was justified because detailed fits, which depended on $\ln m_H^2$, of the electroweak data from the Z pointed to a low value of the Higgs mass, around 100 GeV. The center-of-mass energy leapt to 204 GeV, then in a series of small steps to 209.2 GeV. No sign of a Higgs boson was seen until the data at 206 GeV were analyzed.

In the fall of 2000, ALEPH reported events above the background expected, consistent with a Higgs boson with a mass of 115 GeV. Some confirmation came from L3, but none from DELPHI or OPAL. Combining the data from all events in November 2000, the signal had a 2.9σ significance. Luciano Maiani, the Director General of CERN faced a dilemma. Should he continue to raise the energy of LEP2 and accept a delay in CERN's next big project, the Large Hadron Collider, which was to use the LEP tunnel? The decision was made to terminate LEP2. Further analysis of the data in the summer of 2001 showed that the effect was somewhat smaller, 2.2σ , but whether there is a 115-GeV Higgs boson will be settled by a hadron collider.

Exercises

- 13.1 Use the final LEP values for the width of the Z , σ_{peak} , and R_ℓ to determine N_ν . For Γ_ν/Γ_ℓ use the Standard Model value of 1.99.

- 13.2 Determine the expression for the left–right forward–backward asymmetry for the production of a fermion–antifermion pair at the Z when the initial electron polarization is P . How well can \mathcal{A}_μ be measured with N events of $e^+e^- \rightarrow \mu^+\mu^-$? Assume \mathcal{A}_e is known from measuring the total cross section for left- and right-polarized electrons. Take $P = 0.75$. How much is the measurement of \mathcal{A}_μ improved by using polarized beams? Compare your estimate with SLC Collaboration, K.Abe *et al.*, *Phys. Rev. Lett.* **86**, 1162 (2001).
- 13.3 If a τ at rest decays, the angular distribution of the pion is $dN/d\cos\theta \propto 1 + \cos\theta$, where θ is the angle between the pion's direction and the spin of the τ and the mass of the pion is neglected. Show that this is consistent with the V-A nature of weak interactions. If a high energy τ decays to $\pi\nu$, what is the expected distribution of its visible energy, i.e. the pion's energy, if the τ is left-handed? Consider $Z \rightarrow \tau^+\tau^-$ and let $x = E_\pi/E_\tau$ be the fraction of τ 's energy that is given to the π . Find the joint distribution in θ , the polar angle relative to the e^- direction and x , in terms of \mathcal{A}_e and \mathcal{A}_τ . See, ALEPH Collaboration, A. Heister *et al.*, *Eur. Phys. J.* **C20**, 401 (2001).
- 13.4 The stored LEP electron beam develops a polarization perpendicular to the plane of the ring. As described in Problem 12.4, the electron's spin makes $\nu_0 = \gamma a_e = (E_{beam}/m_e)a_e$ cycles around its polarization for each circuit of the ring, where $a_e \approx \alpha/2\pi$ is the anomalous magnetic moment of the electron in Bohr magnetons. Determine the value of ν_0 when LEP ran at the Z using the more precise value $a_e = 0.0115965$. At a single spot, the electron's spin will seem to advance only by $[\nu_0]$, the non-integer part of ν_0 . If a radial magnetic field is applied with a frequency $[\nu_0]$ times the frequency of the electron's revolution around the ring, electron spins will flip, destroying or reversing the polarization. At LEP, the frequency of the depolarizing resonance was measured to 2 Hz. What uncertainty in the mass of the Z would this cause? See L. Arnaudon *et al.*, *Zeit. f. Phys.* **C66**, 45 (1995).
- 13.5 The W mass can be predicted from the Z mass using the formula

$$m_W^2 = \frac{1}{2} \left[1 + \sqrt{1 - \frac{4\pi\alpha(1 + \Delta r)}{\sqrt{2}m_Z^2 G} F} \right] m_Z^2$$

where Δr incorporates the radiative corrections, including the shift of α from its static value to the value at the scale m_Z . The radiative corrections depend on the value of m_t and m_H . An adequate representation [A. Ferroglila *et al.*, *Phys. Rev.* **D65**, 113002 (2002)] is

$$m_W(\text{GeV}) = 80.387 - 0.572 \ln(m_H/100 \text{ GeV}) - 0.0090 [\ln(m_H/100 \text{ GeV})]^2 + 0.540 [(m_t/174.3 \text{ GeV})^2 - 1].$$

Compare the current measurements of m_t and m_W . What does this indicate about the mass of the Higgs boson? Compare with the direct information from LEP II.

- 13.6 A value of $\sin^2\theta_W$ can be inferred from measurements of the forward–backward asymmetry at LEP. Within the Standard Model, it can be predicted in terms of the

three basic parameters, α , G_F , and m_Z if m_t and m_H are known. The latter two occur through radiative corrections. An adequate representation is

$$\begin{aligned} \sin^2 \theta_{eff}^{lept} = & 0.2314 + 4.9 \times 10^{-4} \ln(m_H/100 \text{ GeV}) \\ & + 3.41 \times 10^{-5} [\ln(m_H/100 \text{ GeV})]^2 \\ & - 2.7 \times 10^3 [(m_t/174.3 \text{ GeV})^2 - 1]. \end{aligned}$$

The results from LEP for the forward–backward asymmetry for leptonic final states gave $\sin^2 \theta_{eff}^{lept} = 0.23113(21)$ while for hadronic final states the result was $\sin^2 \theta_{eff}^{lept} = 0.23220(29)$. What do these results suggest about the mass of the Higgs? Compare with the results of Exercise 13.5.

Further Reading

ALEPH, DELPHI, L3, OPAL, and SLD Collaborations, LEP Electroweak Working Group, SLD Electroweak and Heavy Flavor Working Groups, “Precision Electroweak Measurements at the Z Resonance,” *Phys. Rep.* **427**, 257 (2006).

References

- 13.1 G. A. Abrams *et al.*, “Initial Measurements of Z -boson Resonance Parameters in e^+e^- Annihilation.” *Phys. Rev. Lett.*, **63**, 724 (1989).
- 13.2 F. Abe *et al.*, “Measurement of the Mass and Width of the Z^0 Boson at the Fermilab Tevatron.” *Phys. Rev. Lett.*, **63**, 720 (1989).
- 13.3 L3, “A Determination of the Properties of the Neutral Intermediate Vector Boson Z^0 .” *Phys. Lett.*, **B 231**, 509 (1989).
- 13.4 ALEPH, “The Number of Light Neutrino Species.” *Phys. Lett.*, **B 231**, 519 (1989).
- 13.5 OPAL, “Measurement of the Z^0 Mass and Width with the OPAL Detector at LEP.” *Phys. Lett.*, **B 231**, 530 (1989).
- 13.6 DELPHI, “Measurement of the Mass and Width of the Z^0 -particle from Multi-hadronic Final States Produced in e^+e^- Annihilations.” *Phys. Lett.*, **B 231**, 539 (1989).
- 13.7 SLD, “Direct Measurement of Leptonic Coupling Asymmetries with Polarized Z Bosons.” *Phys. Rev. Lett.*, **79**, 804 (1997).