

# Muon Detector



UNIVERSITÀ DI PAVIA  
Dipartimento di Fisica  
“Alessandro Volta”



Ilaria Vai<sup>1,2</sup> on behalf of the CMS Muon Group

<sup>1</sup>Dipartimento di Fisica, Università di Pavia

<sup>2</sup>INFN Sezione di Pavia

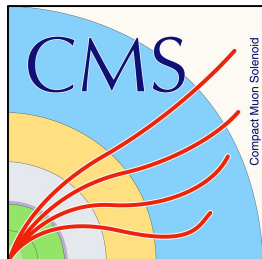

14th International Conference on New Frontiers in Physics – ICNFP 2025  
17–31 July 2025 – Kolymbari, Crete, Greece

# The CMS experiment @ the LHC

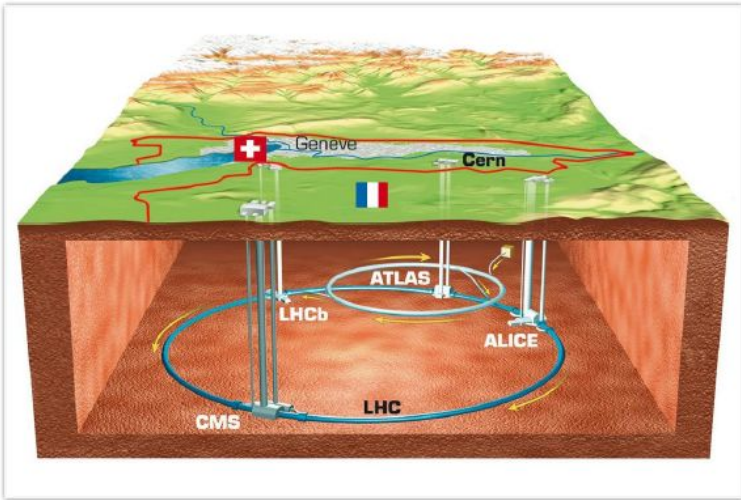

## CMS DETECTOR

Total weight : 14,000 tonnes  
 Overall diameter : 15.0 m  
 Overall length : 28.7 m  
 Magnetic field : 3.8 T

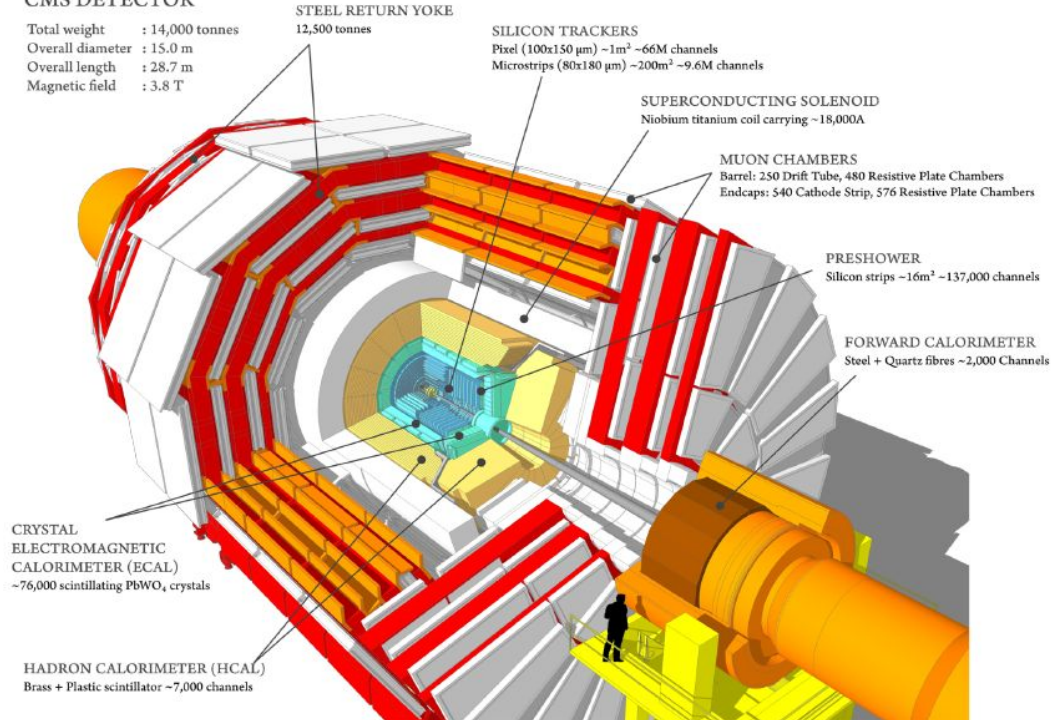

# The CMS Muon System

## Drift Tubes (DT)

- 250 chambers
- Spatial resolution  $\sim 100 \mu\text{m}$
- Time resolution  $\sim 2 \text{ ns}$

## Resistive Plate Chambers (RPC)

- 576 + 480 chambers
- Spatial resolution  $\sim 1 \text{ cm}$
- Time resolution  $\sim 1.5 \text{ ns}$

## Cathode Strip Chambers (CSC)

- 540 chambers
- Spatial resolution  $\sim 40 - 160 \mu\text{m}$
- Time resolution  $\sim 3 \text{ ns}$

## Gas Electron Multiplier (GEM):

- GE1/1 installed in 2021
- 72 Super-Chambers
- Spatial resolution  $\sim 100 \mu\text{m}$
- Time resolution  $\sim 10 \text{ ns}$

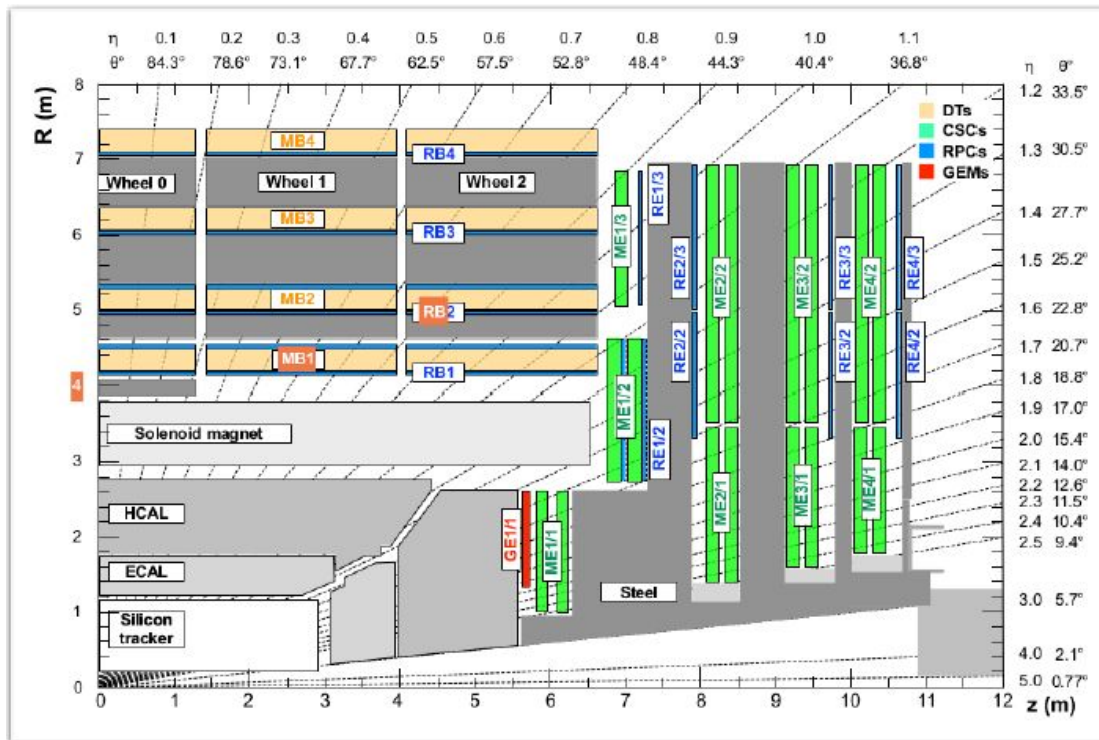

# LHC Schedule

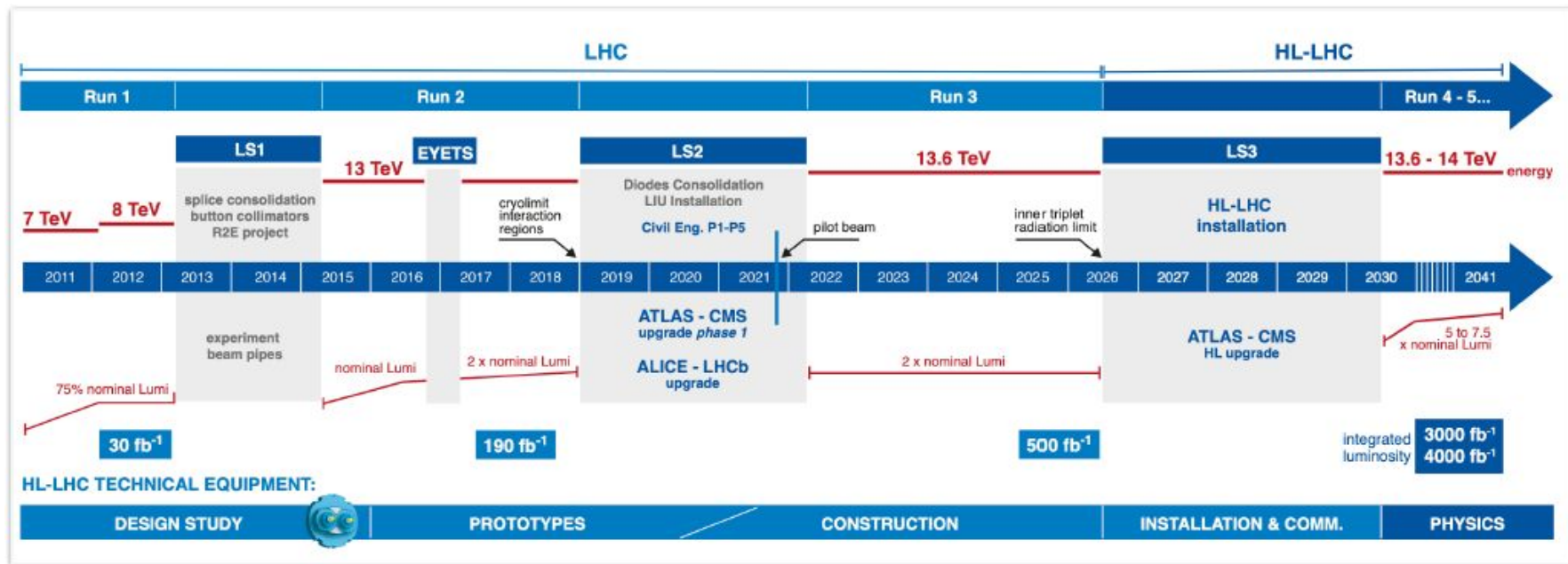

# Why do we need to intervene on our detector?

Phase 2 Upgrade brings 5xLHC design luminosity:

- Event pileup reaches ~140 collisions per beam crossing (@ 25ns)
- Detector elements and electronics are exposed to high radiation dose

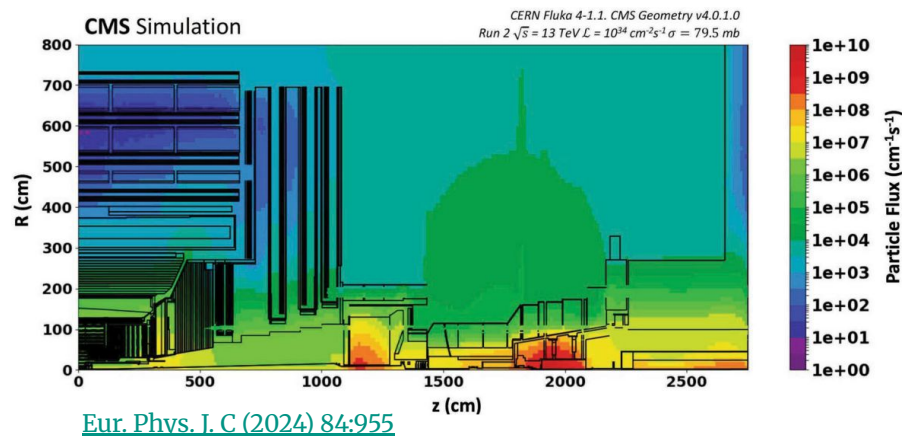
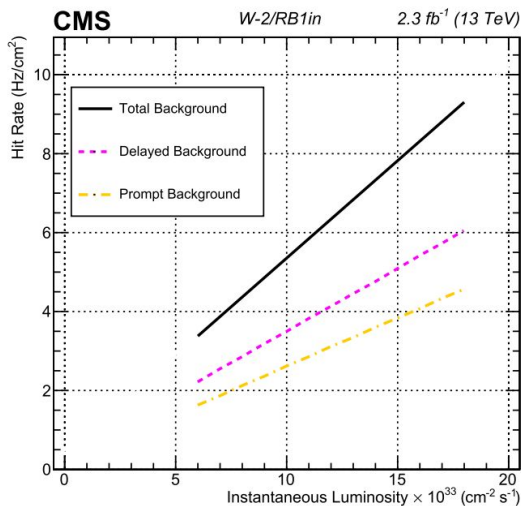

# CMS Muon System Upgrades

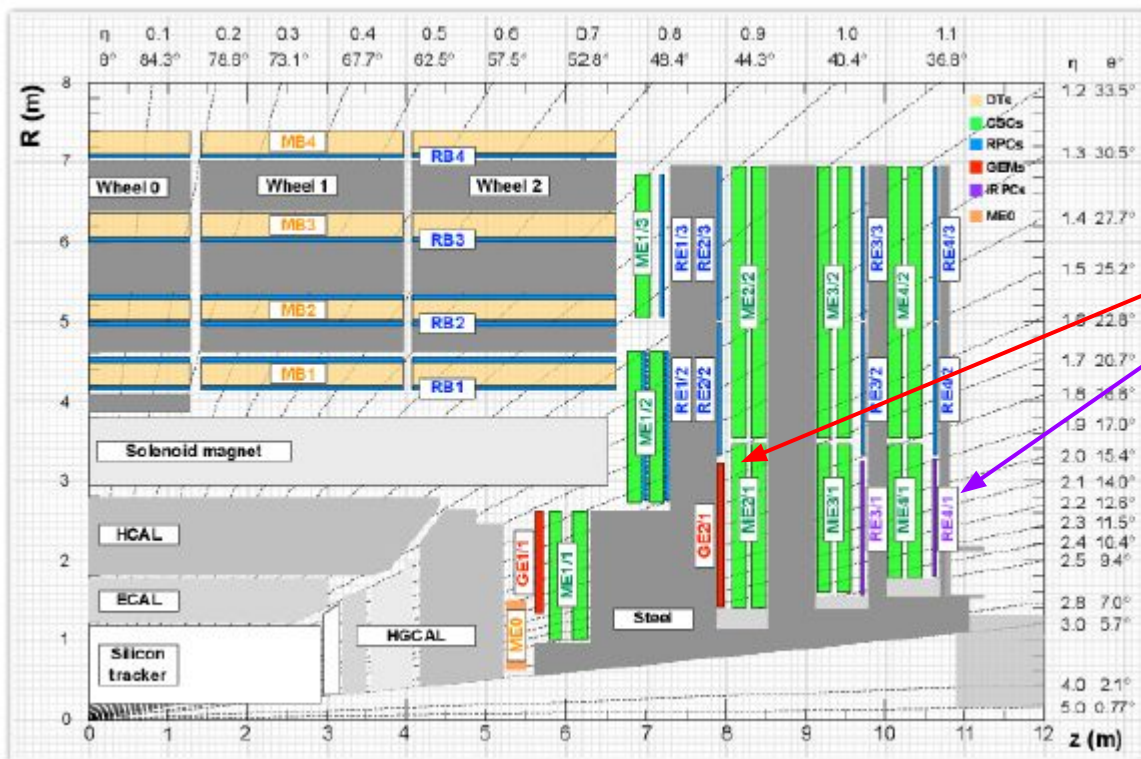

New detectors  
 +  
 Electronics upgrade for existing detectors  
 +  
 Longevity and Eco-gas studies

# Upgrade of the existing detectors – DT

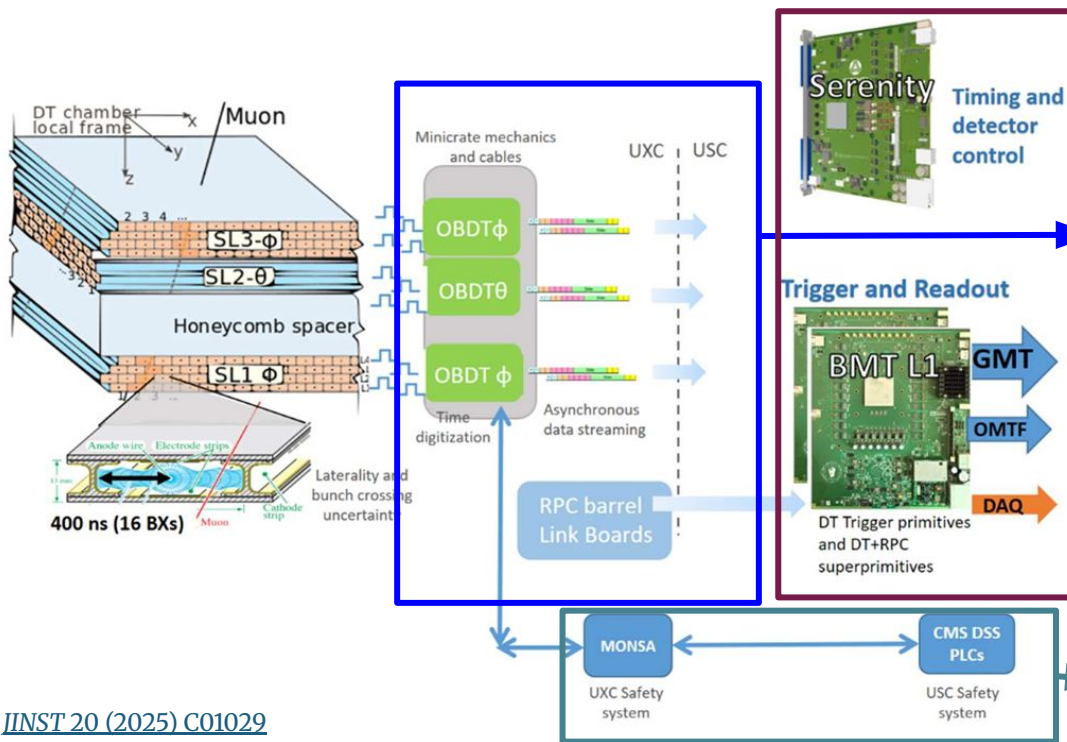

DT upgrade focused on the Front-end (FE) & the Back-end (BE) electronics

**Front-end:** Minicrate structures attached to the DT chambers embed the new on detector electronics

**Back-end:** two types of backend for “Timing and Detector Control” and for “Trigger and Readout”

**Monitor and Safety (MONSA)** system for monitoring the OBDT status, connected to CMS detector safety system (DSS)

# The slice-test demonstrator of sector 12

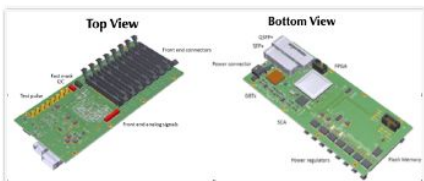
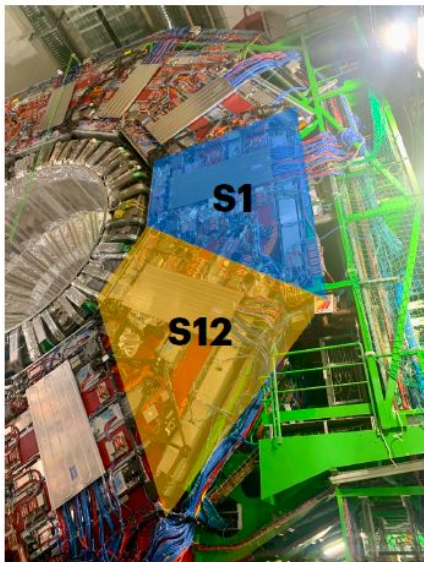

## Sector 12 Slice Test:

- 13 early prototypes of OBDT (v1) boards installed during LS2 (same OBDT boards for Theta & Phi superlayers)
- The legacy electronics chain & and the upgrade chain register the same event splitted
- Extensive data-taking during cosmic and collision runs to test the soundness of DT electronics, the upgrade strategy & data fully integrated in CMS

<https://doi.org/10.22323/1.449.0518>

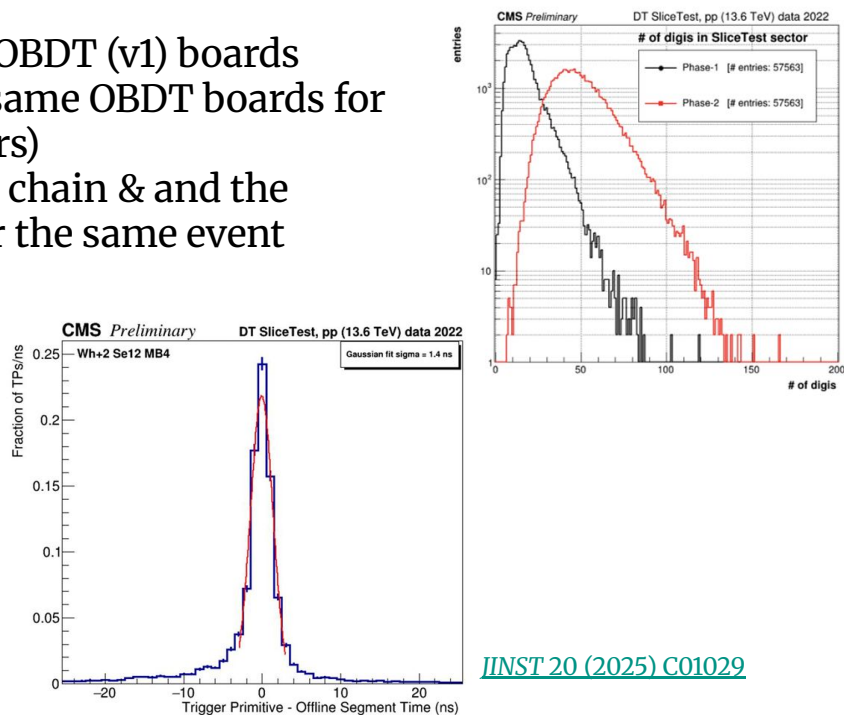

# The slice-test demonstrator of sector 1

Extended the slice-test demonstrator concept to **Sector 1**.

- Equipped with OBDT v2, near to final version
- Different board for each super-layer  $\theta$  and  $\varphi$
- Major differences w.r.t to version 1:
  - GBTx -> LpGBT
  - SFP+/QSFP -> VTRX+ (dual)
  - New Safety subsystem is on Board

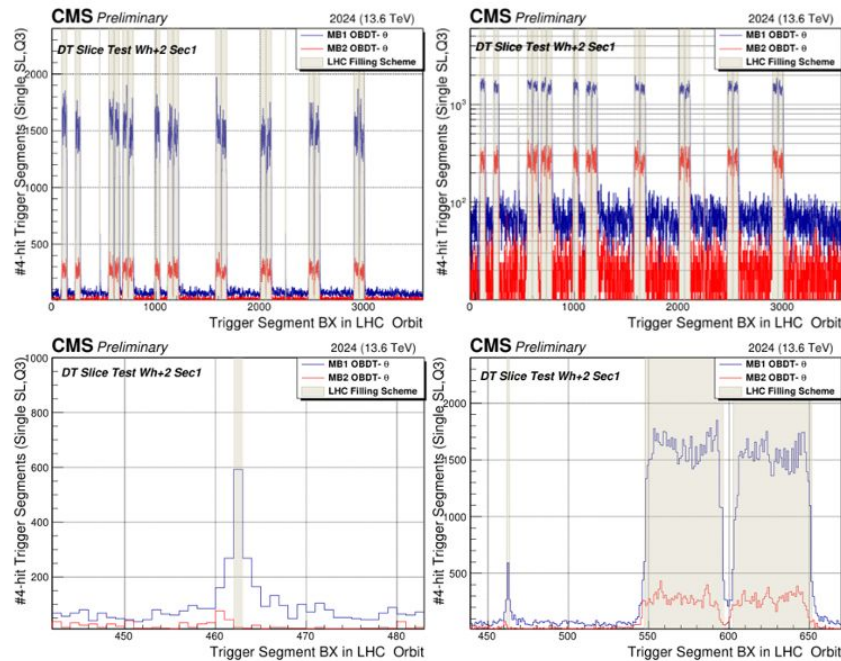

**Figure 3.** Distribution of the BX measurement of the TPs coming from the SuperLayers  $\theta$  of MB1 (blue line) and MB2 (red line) as reconstructed by the AM algorithm running in the BMTL1 prototype in linear (top left) and log scale (top right). The LHC filling scheme is indicated by the shaded area. Bottom plots show the same data zooming in different regions of the orbit.

# Upgrade of the existing detectors – CSC

<https://doi.org/10.22323/1.449.0518>

**LS2**  
Anode Local Charged Track electronics: replace mezzanine cards to increase latency capability and output bandwidth

**LS2**  
Cathode Front End Boards: replace with Digital Cathode Front End Boards with increased latency and rate capabilities

**LS3**  
Front End Driver: increased data volume, number of links

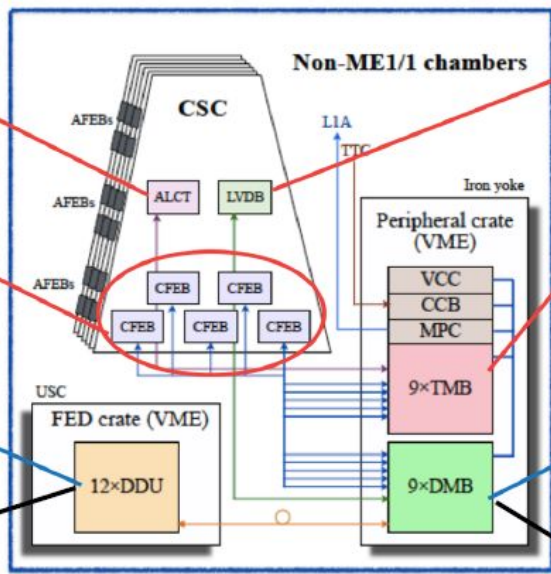

**LS2**  
Low Voltage Distribution Boards: replace to provide voltages and currents for Digital Cathode Front End Boards

**LS2**  
Trigger Motherboard: replace with optical Trigger Motherboard to receive Digital Cathode Front End Board trigger data, increased algorithmic power

**LS3**  
Data Motherboard: replace with optical Data Motherboard to receive Digital Cathode Front End Board data

In LS3, CSC upgrade will focus on off detector upgrade, replacing ODMB with new version boards and back end upgraded FED (Advanced Telecommunications Computing Architecture (ATCA) FED)

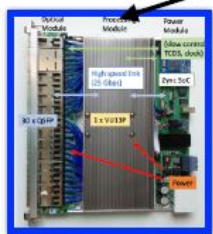

# RPC: working on both frontlines!

## New RPC Link system

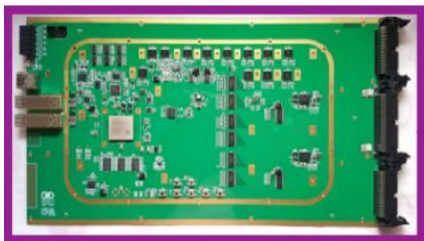

### New Link System:

- Improve Trigger hit time resolution from **25 ns** to **1.56 ns**
- Data transmission speed up to **10.24 Gbps**

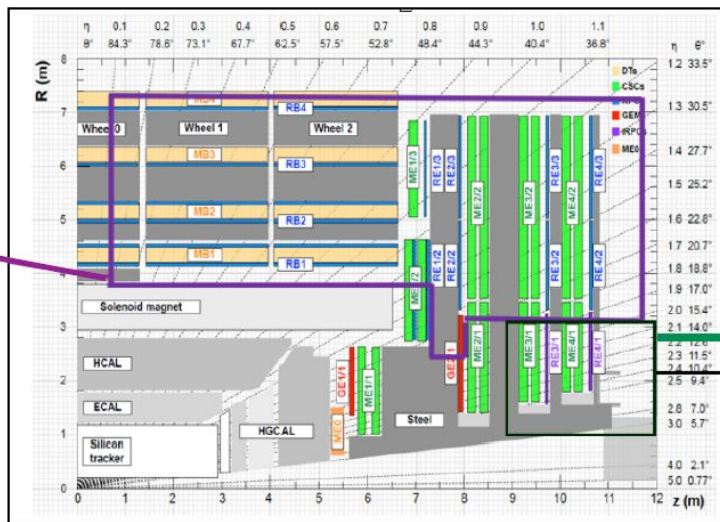

### New Improved RPCs (iRPCs)

iRPC are able to sustain high expected rates of up to 2 kHz/cm<sup>2</sup>, with hit efficiency > 95%

## New Improved RPCs for Ring 1 of end-cap discs 3/4 (RE3/1, RE4/1)

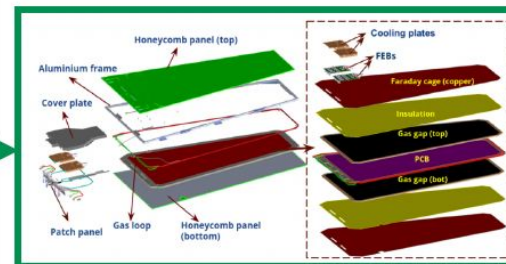

- 1 chamber = 1.6 x 1.2 m<sup>2</sup>
- Total 72 iRPC (20<sup>0</sup>) chambers
- 1.8 < |η| < 2.4

# Upgrade of the existing detectors – RPC

The present RPC Link system will be replaced with the new Link System in LS3

The main goal is to replace present electronics with brand-new high-performance ones

## Key Features of new Link System

- 14 Layer PCB, 40 × 28 cm<sup>2</sup>
- FPGAs are KINTEX-7, XC7K160T – Industrial Version
- Muon hit time, TDC timing Resolution : 1.56 ns
- Master Link board output data rate : 10.24 Gbps
- Control Board communication with RPC Backend electronics: 4.8 Gbps

<https://indico.global/event/6191/timetable/?view=standard#179-cms-rpc-link-system-fiber>

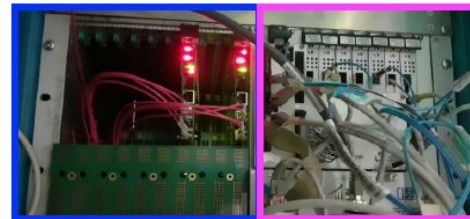
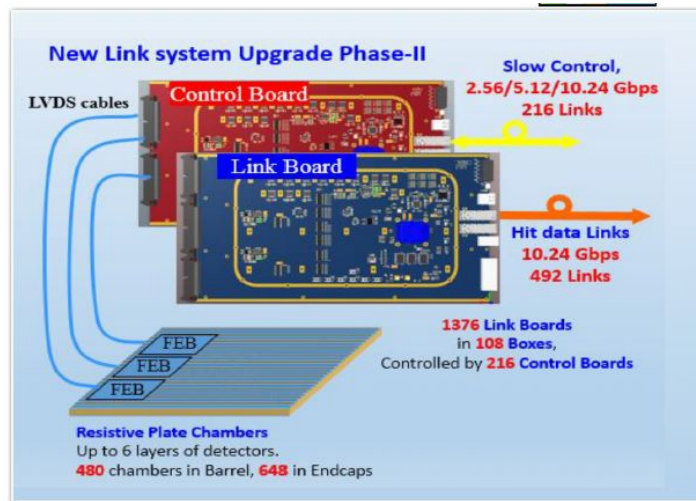

New Link System (left) and present Link System (right) at CMS experimental cavern (UXC)

# New Improved RPCs

## Requirements:

- Space resolution (cm): 1.5 in  $\eta$  and 0.3-0.6 in  $\phi$
- Time resolution (ns): 0.5 ns
- Rate capability: 2 kHz/cm<sup>2</sup>

	Present	iRPC
<b>HPL Resistivity</b> (Ohm/cm)	1-6x10 <sup>10</sup>	0.9-3 x10 <sup>10</sup>
<b>Gap thickness</b>	2mm	1.4mm
<b>Electrode thickness</b>	2 mm	1.4mm
<b>Rate Capability</b> (Safety factor=3 included)	600 Hz/cm <sup>2</sup>	2 kHz/cm <sup>2</sup>
<b>Max int. charge@3ab<sup>-1</sup></b> (SF = 3 included)	~ 0.8 C/cm <sup>2</sup>	~ 1.0 C / cm <sup>2</sup>
<b>Phi granularity</b>	~ 0.3°	~ 0.2°
<b>Eta resolution</b>	~ 20 cm	~ 2 cm
<b>Time resolution</b>	1.5 ns	< 1 ns

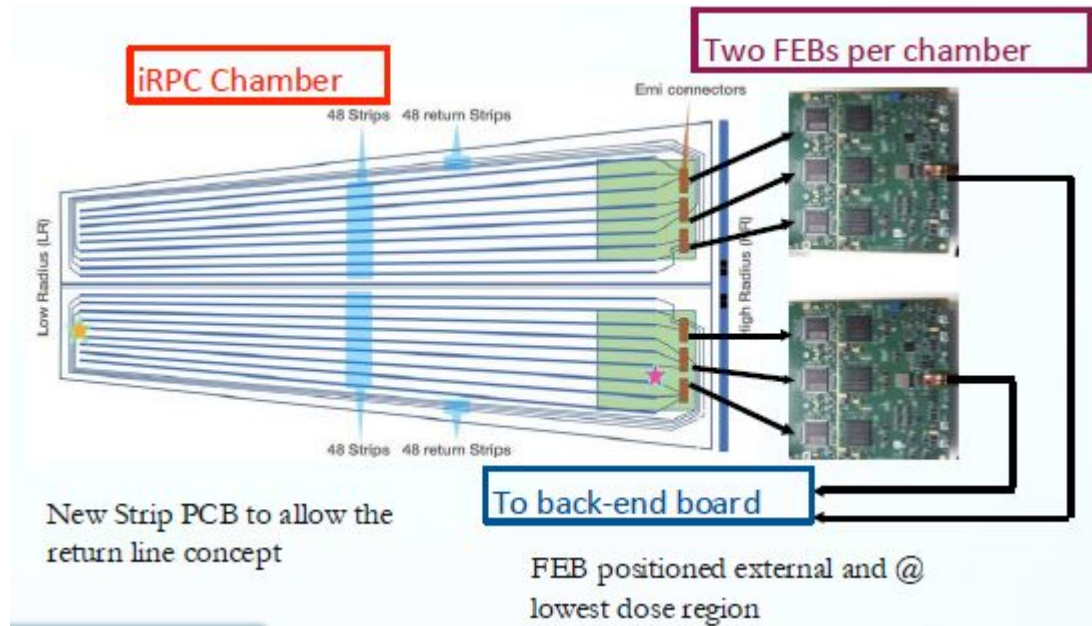

[https://agenda.infn.it/event/37033/contributions/227922/attachments/120553/175429/RP\\_C2024PisaMeetings\\_Ioaov3-2.pdf](https://agenda.infn.it/event/37033/contributions/227922/attachments/120553/175429/RP_C2024PisaMeetings_Ioaov3-2.pdf)

# iRPC: Design and performance

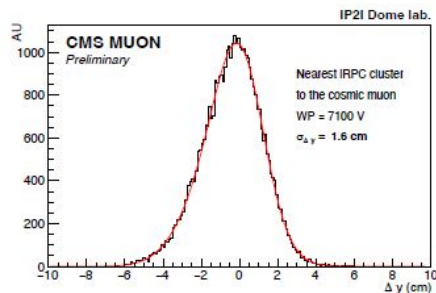
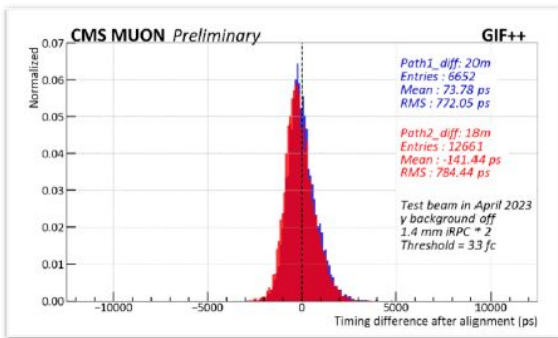

Space resolution in  $\eta$  direction 1.6 cm

Absolute time resolution of RPC is 780ps, per chamber is around 550ps

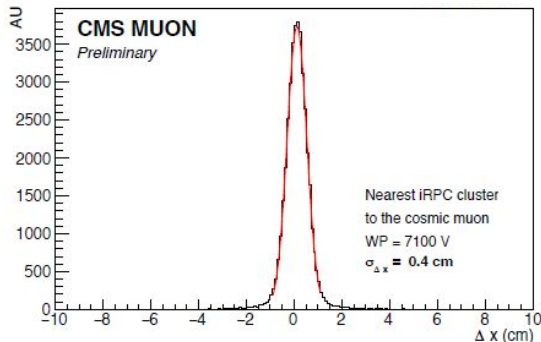

Space resolution in  $\phi$  direction is 0.4 cm.

[https://agenda.infn.it/event/37033/contributions/227922/attachments/120553/175429/RPC2024PisaMeetings\\_Ioav3-2.pdf](https://agenda.infn.it/event/37033/contributions/227922/attachments/120553/175429/RPC2024PisaMeetings_Ioav3-2.pdf)

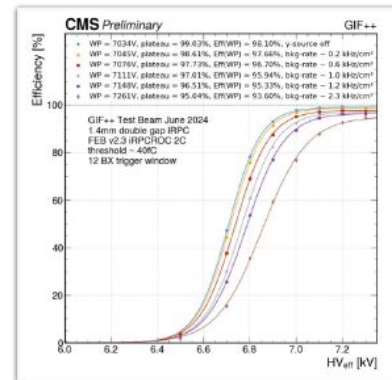

Efficiency @ 2.3 kHz/cm<sup>2</sup> : 95 % 14

# New Gas Electron Multipliers

## 3 projects based on Gas Electron Multiplier (GEM) Technology

- GE1/1, GE2/1: complementing CSC in forward region (Station 1 & 2 for Ring 1)
- MEO: Extending muon system acceptance in very forward region

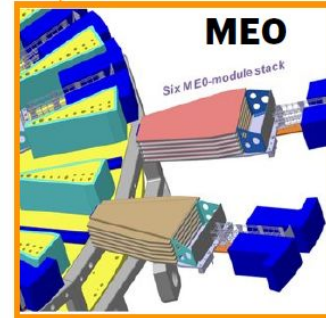
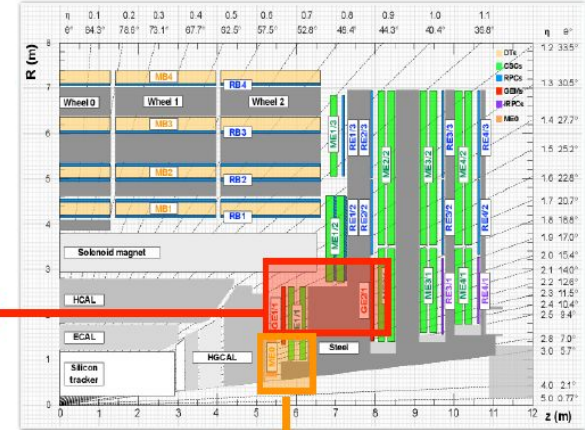
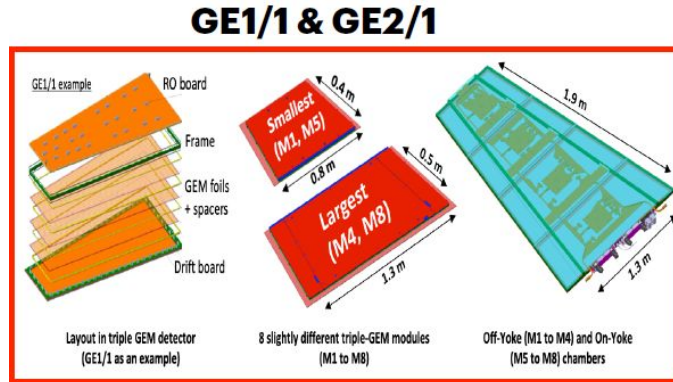

See dedicated [talk](#) by Shalini Thakur!

# GE1/1 performance

GE1/1 chambers installed during long shutdown 2 (LS2) and running since the beginning of Run 3

- GEM detectors in CMS Run 3 show stable performance with  $\sim 95\%$  efficiency, muon detection and triggering.
- During Year-End Technical Stop (YETS) in 2024-2025, six GE1/1 chambers were removed to address specific operational issues.
- Additionally, four GE2/1 chambers installed to gain operational experience during YETS2024-25.

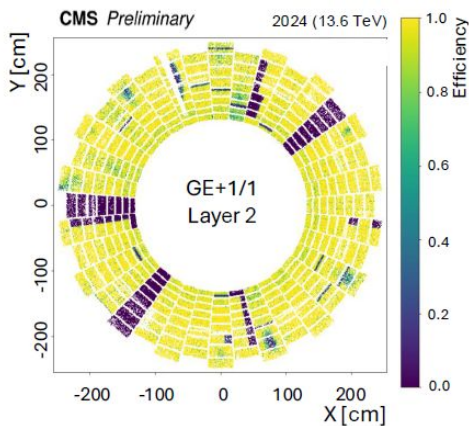

GE+1/1 L2 efficiency (2024): High overall, with purple indicating issues (communication or HV shorts).

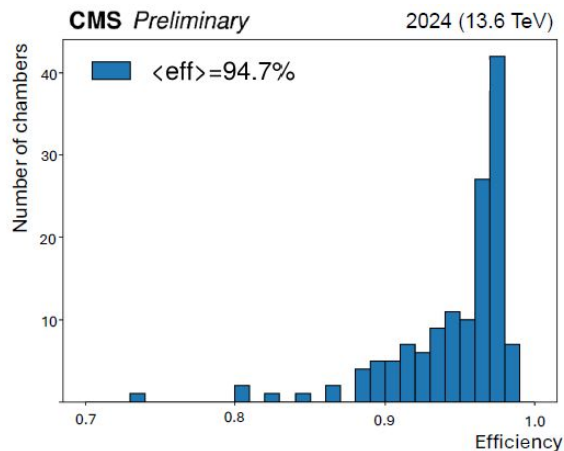

Efficiency of 140 GE1/1 chambers with HV in 2024

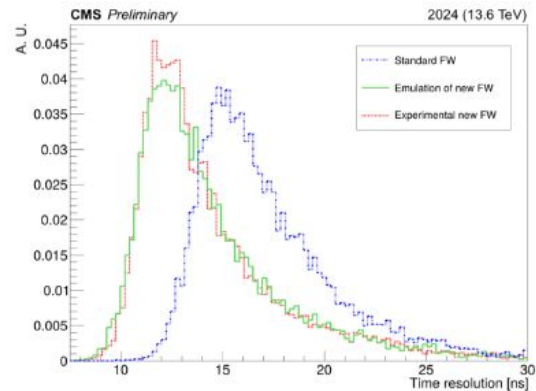

The GE1/1 time resolution: significant improvement from 15 ns to 10 ns

# Gas mixtures

CSC and RPC gas mixtures contain *fluorinated greenhouse gases*, ( $\text{SF}_6 \sim 0.5\%$ ,  $\text{C}_2\text{H}_2\text{F}_4 \sim 95\%$ ,  $\text{CF}_4 \sim 10\%$ ) classified for their Global Warming Potential with respect to  $\text{CO}_2 \rightarrow$  Extensive R&D program ongoing since 2016:

- A full-scale CSC longevity study using 5%  $\text{CF}_4$  started in GIF++ in September 2022. No evidence of performance degradation has been observed so far.
- A new gas  $\text{C}_3\text{H}_2\text{F}_4$  (HFOze) GWP~6 to replace  $\text{C}_2\text{H}_2\text{F}_4$  (TFE) GWP~1430 is studied for the RPCs.

[Nucl. Instrum. Methods Phys. Res., A 1069 \(2024\) 169950](#)

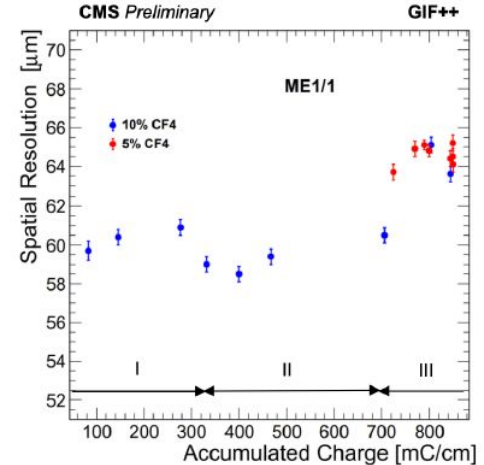
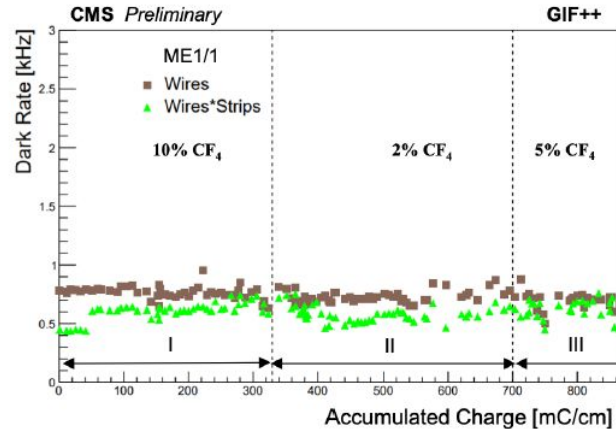
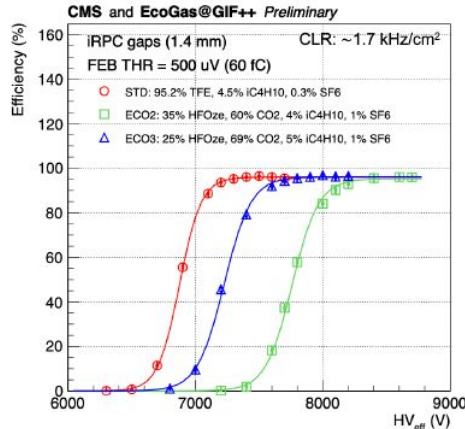

# Summary

The CMS Muon System is undergoing several upgrade projects to cope with the HL-LHC conditions:

- Legacy detectors are improving their electronics, to cope with the enhanced event rate and background conditions
- New detectors (iRPCs and GEMs) are being installed in the high-eta region
- Restrictions on greenhouse F-gas usage have led to further studies: test with various gas mixtures have shown no signs of CSC aging, and more environmentally friendly alternatives are being evaluated with promising results.

# Thank you for your attention!