

Joint Universities Accelerator School

JUAS 2025

18. – 24. February 2025

# Normal-conducting accelerator magnets

## Lecture 5: Analytical design



Thomas Zickler

CERN



# Design process

Electro-magnetic design is an iterative process:

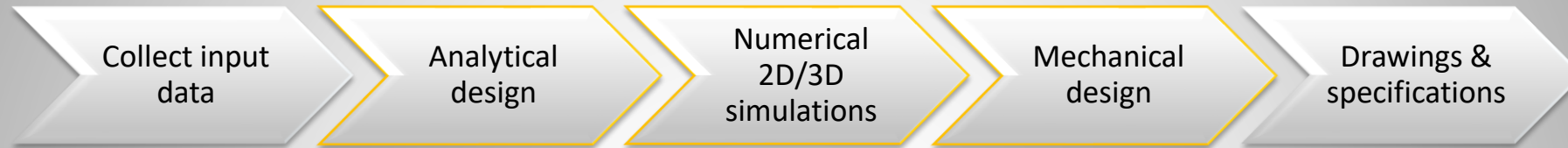

- Field strength (gradient) and magnetic length
- Integrated field strength (gradient)
- Aperture and ‚good field region‘
- Field quality:
  - field homogeneity
  - maximum allowed multi-pole errors
  - settling time (time constant)
- Operation mode: continuous, cycled
- Electrical parameters
- Mechanical dimensions
- Cooling requirements

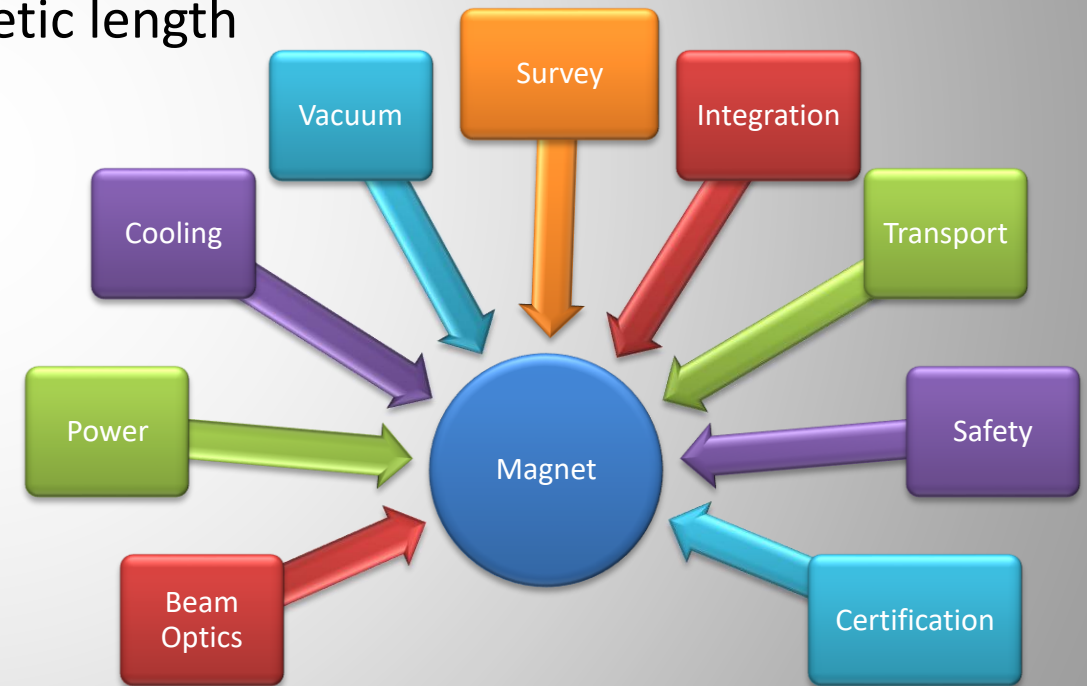

*A magnet is not a stand-alone device!*



# Magnet Components

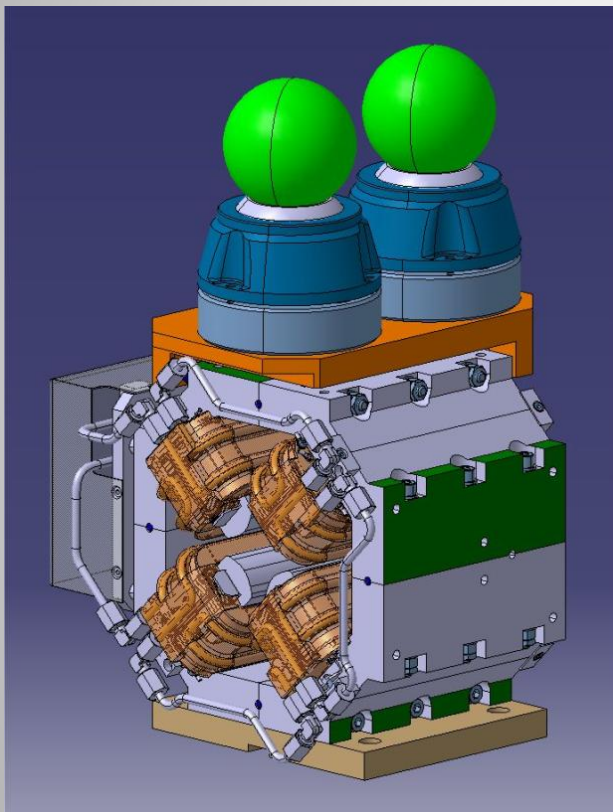

Alignment targets

Yoke

Coils

Sensors

Cooling circuit

Connections

Support

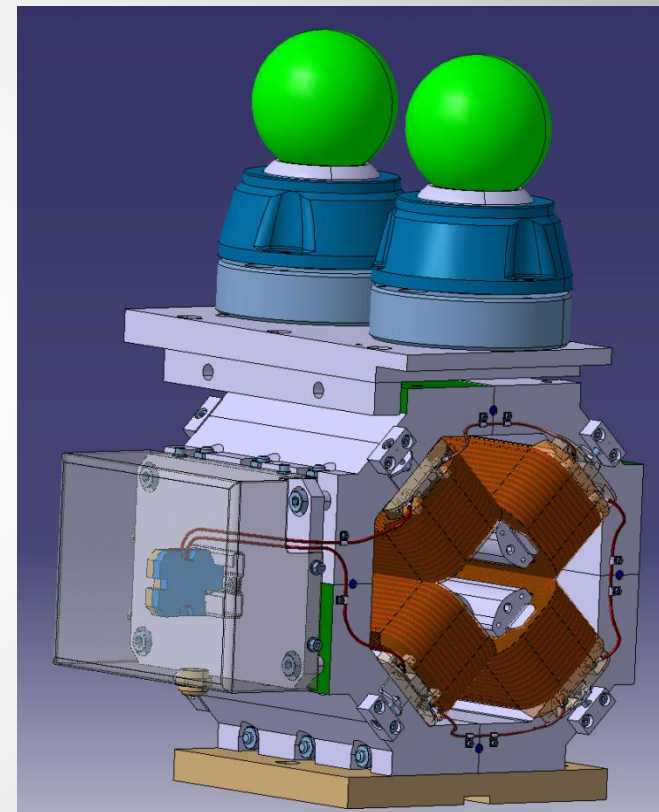



# Beam rigidity

Beam rigidity ( $B\rho$ ) [Tm]:

$$(B\rho) = \frac{p}{q} = \frac{1}{qc} \sqrt{E_k^2 + 2E_k E_0}$$

$p$ : particle momentum [kg m s<sup>-1</sup>]

$q$ : particle charge [C or A s]

$c$ : speed of light [m s<sup>-1</sup>]

$E_k$ : kinetic beam energy [eV]

$E_0$ : particle rest mass energy [eV]  
( 0.51 MeV for electrons; 938 MeV for protons)

*” ...resistance of the particle beam against a change of direction when applying a bending force...”*



# Magnetic induction

Dipole bending field  $B$  [T]:

$B$ : Flux density or magnetic induction  
(vector) [T]

$r_M$ : magnet bending radius [m]

$$B = \frac{(B\rho)}{r_M}$$

Quadrupole field gradient  $B'$  [T/m]:

$k$ : quadrupole strength [m<sup>-2</sup>]

$$B' = (B\rho)k$$

Sextupole differential gradient  $B''$  [T/m<sup>2</sup>]:

$j$ : sextupole strength [m<sup>-3</sup>]

$$B'' = (B\rho)j$$



# Excitation current in a dipole

Ampere's law  $\oint \vec{H} \cdot d\vec{s} = NI$  and  $\vec{B} = \mu \vec{H}$  with  $\mu = \mu_0 \mu_r$

leads to  $NI = \oint \frac{\vec{B}}{\mu} \cdot d\vec{s} = \int_{air} \frac{\vec{B}}{\mu_{air}} \cdot d\vec{s} + \int_{iron} \frac{\vec{B}}{\mu_{iron}} \cdot d\vec{s} = \frac{Bh}{\mu_{air}} + \frac{B\lambda}{\mu_{iron}}$

assuming, that  $B$  is constant along the path

If the iron is not saturated:  $\frac{h}{\mu_{air}} \gg \frac{\lambda}{\mu_{iron}}$

then:  $NI_{(perpole)} \approx \frac{Bh}{2\mu_0}$

$h$ : gap height [m]

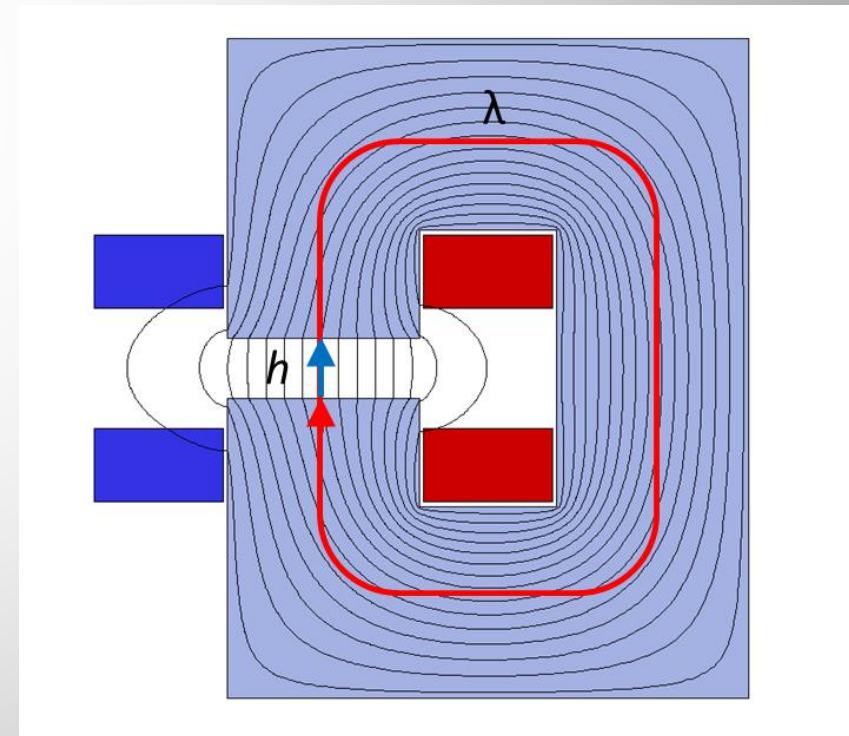



# Excitation current in a Quadrupole

Choosing the shown integration path gives:  $NI = \oint \vec{H} \cdot d\vec{s} = \int_{s_1} \vec{H}_1 \cdot d\vec{s} + \int_{s_2} \vec{H}_2 \cdot d\vec{s} + \int_{s_3} \vec{H}_3 \cdot d\vec{s}$

For a quadrupole, the gradient  $B' = \frac{dB}{dr}$  is constant

and  $B_y = B'x$        $B_x = B'y$

Field modulus along  $s_1$ :  $|H(r)| = \sqrt{H_x^2 + H_y^2} = \frac{B'}{\mu_0} \sqrt{x^2 + y^2} = \frac{B'}{\mu_0} r$

Neglecting  $H$  in  $s_2$  because:  $R_{M,s2} = \frac{s_2}{\mu_{iron}} \ll \frac{s_1}{\mu_{air}}$

and along  $s_3$ :  $\int_{s_3} \vec{H}_3 \cdot d\vec{s} = 0$

Leads to:  $NI \approx \int_0^R H(r) dr = \frac{B'}{\mu_0} \int_0^R r \cdot dr$

$$NI_{(per\ pole)} = \frac{B'r^2}{2\mu_0}$$

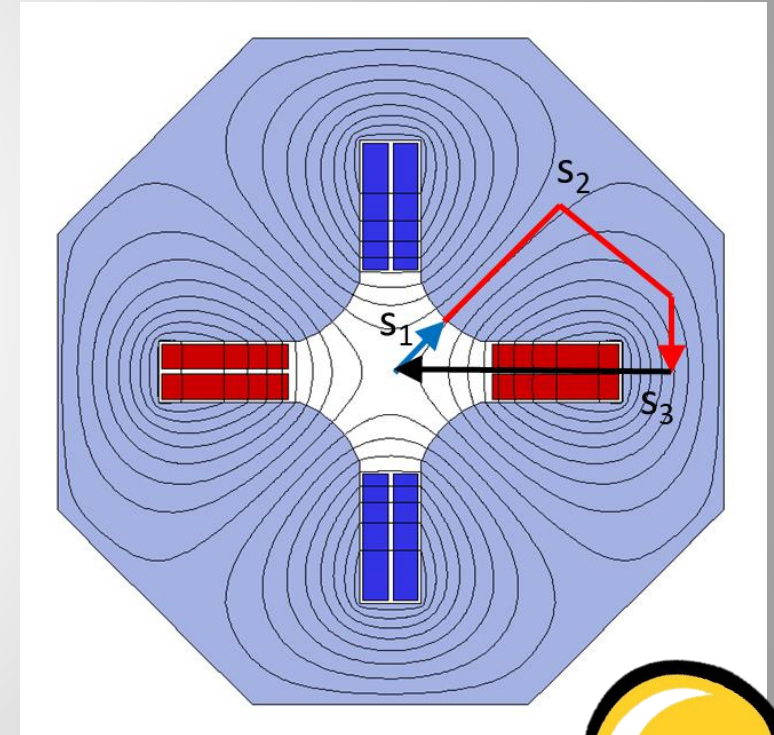



# Aperture size

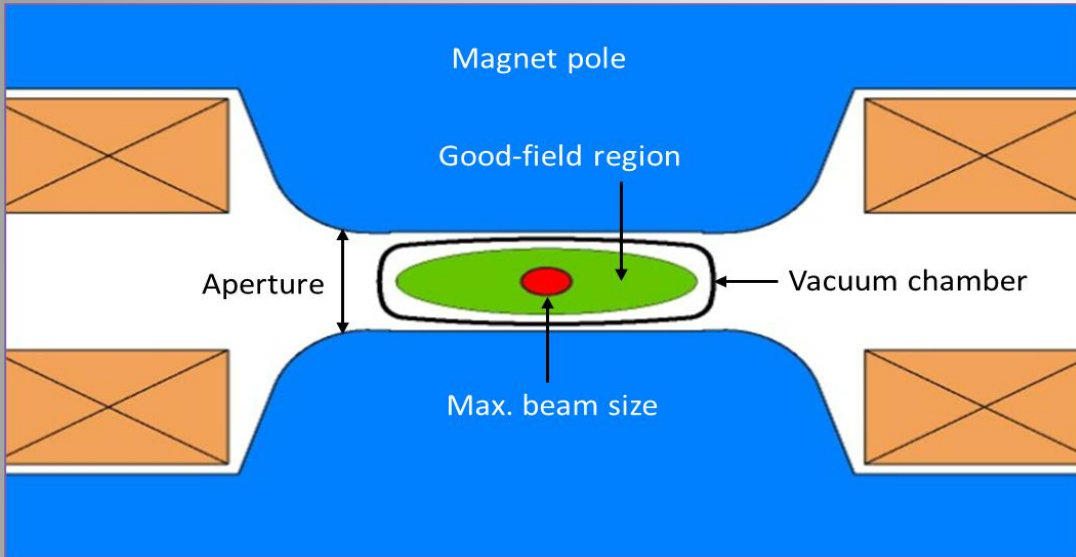

*“...good-field region: central region around the theoretical beam trajectory where the field quality has to be within certain tolerances...”*

- Aperture**
  - Good-field region**
    - Max. beam size envelope (typical 3-sigma)**
      - Lattice functions: beta functions and dispersion
      - Geometrical transverse emittances (energy depended)
      - Momentum spread
    - Closed orbit distortions (few mm)**
  - Vacuum chamber thickness (0.5 – 5 mm)
  - Installation and alignment margin (0 – 10 mm)





# Pole design

It is easy to derive an **ideal** mathematical pole configuration for a specific field configuration

In practice, poles are **not ideal**: finite width and end effects result in (allowed) multipole errors disturbing the fundamental field

The uniform field region is limited to a small fraction of the pole width:

Estimate the size of the poles and calculate the resulting fields numerically

Better approach: calculate the necessary pole overhang

$$x_p = \frac{h}{2} f \left( \frac{\Delta B}{B_0} \right)$$

$$f \left( \frac{\Delta B}{B_0} \right)_{\text{unopt.}} = -0.36 \ln \frac{\Delta B}{B_0} - 0.90$$

$x_p$ : pole overhang: excess pole beyond the edge of the GFR

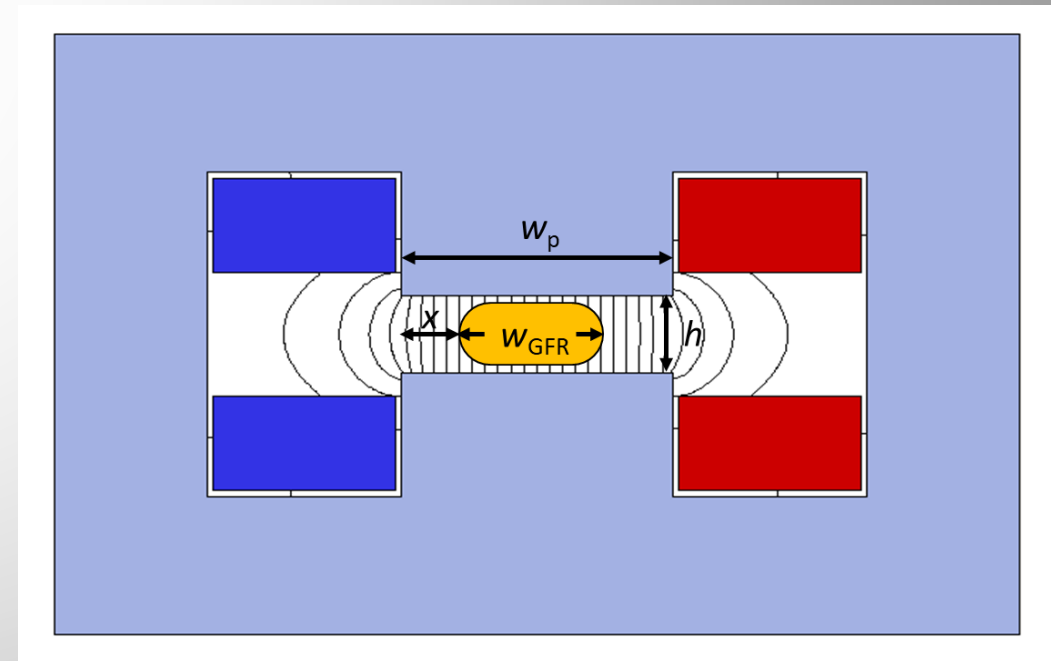



# Pole optimization

To improve the field quality in the GFR we can either **increase** the pole width or **optimize** the pole profile by **shimming**:

- Add or remove material on the pole profile (shims)
- Taper or round-off pole edges to reduce saturation
- Often done by trial-and-error

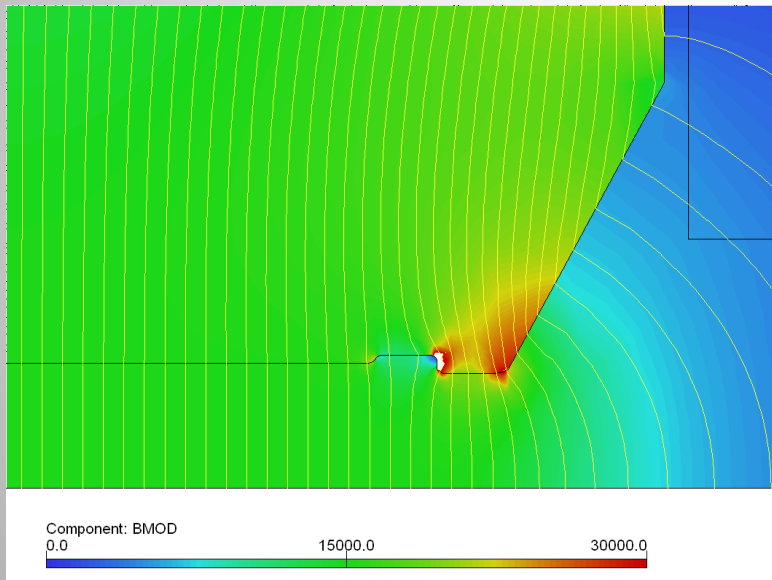

For an **optimized** pole:

$$f\left(\frac{\Delta B}{B_0}\right)_{opt.} = -0.14 \ln \frac{\Delta B}{B_0} - 0.25$$

Please note: the final field quality will depend on the longitudinal pole profile, coil ends, mechanical tolerances, assembly errors, possible inhomogeneities in the magnetic properties, and saturation



# Yoke dimensioning

Total flux in the return yoke includes the flux from the aperture and the stray flux outside the gap

$$\Phi = \int_a B \cdot da \approx B_{gap}(w + 2h) l_{eff}$$

$$B_{leg} \cong B_{gap} \frac{w + 2h}{w_{leg}} \quad (\text{ignoring the 3rd dimension})$$

Avoid saturation in the yoke

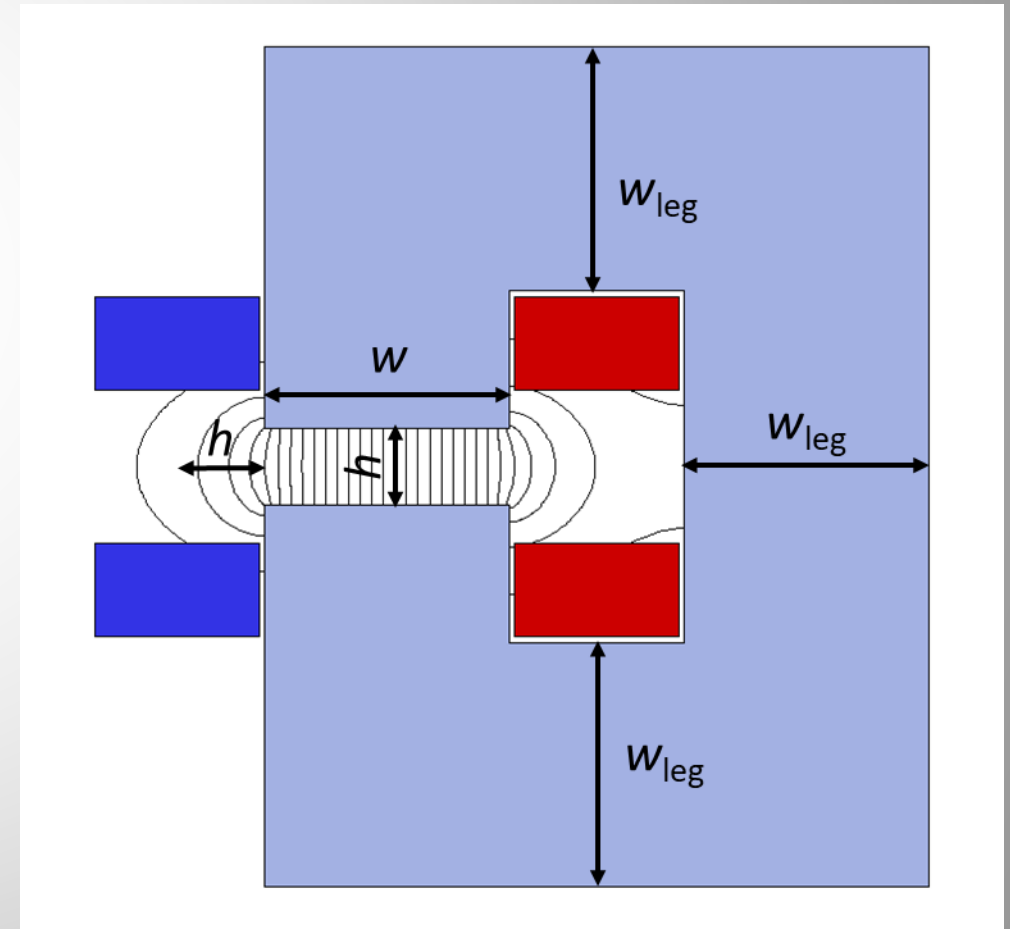
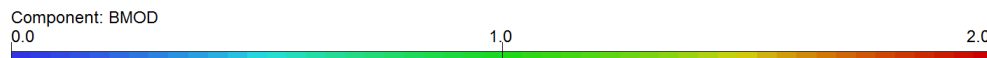
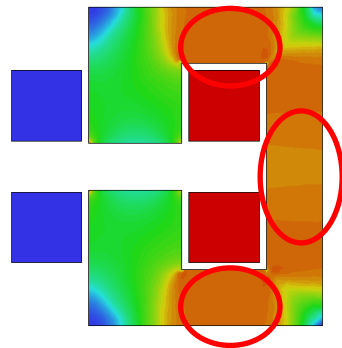



# Effective length

Coming from  $\infty$ ,  $B$  increases towards the magnet center:

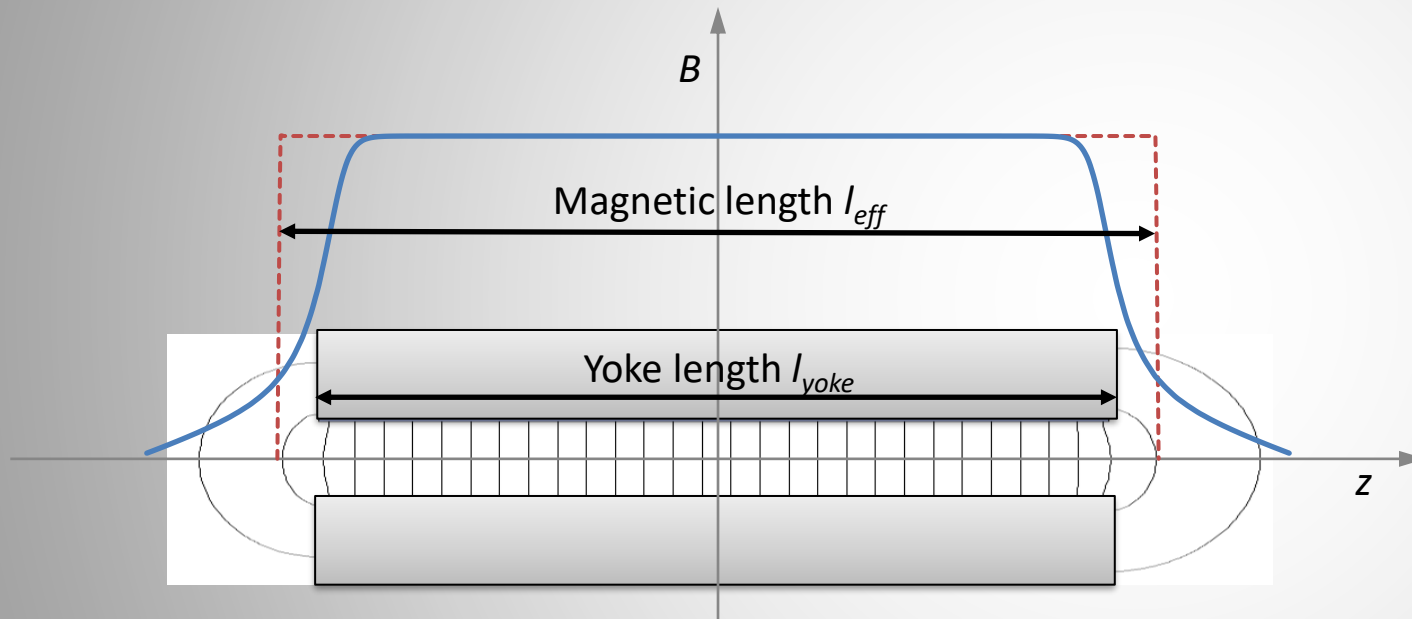

Effective or magnetic length: 
$$l_{eff} = \frac{\int_{-\infty}^{\infty} B(z) dz}{B_0}$$

Effective length > yoke length

Approximation for a dipole:  $l_{eff} \approx l_{yoke} + h$

Approximation works only if:

- pole length  $\gg$  gap height
- saturation is negligible





# Sagitta

*View on the pole from the top*

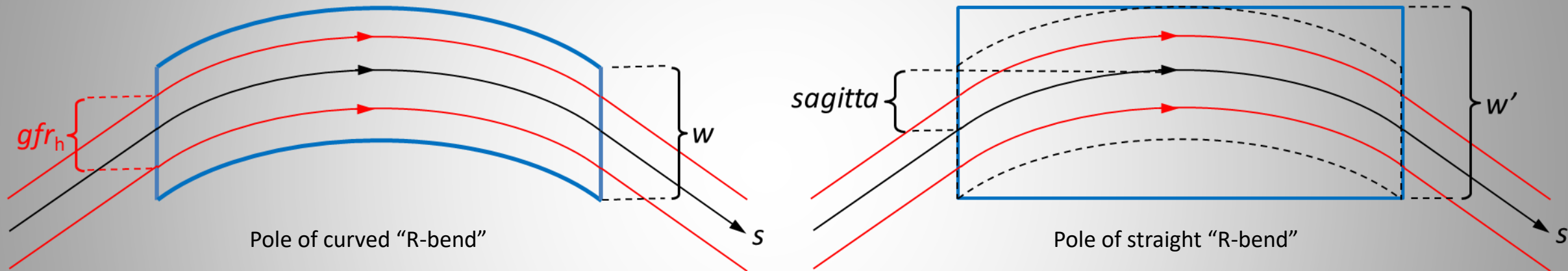

For straight magnets, the horizontal pole width has to be enlarged by the **sagitta**:

$$s = r_M \left( 1 - \cos\left(\frac{\alpha}{2}\right) \right)$$



# Coil design

Ampere-turns  $NI$  are determined, but for the coil design, the number of turns  $N$  and the current density  $J$  need to be found

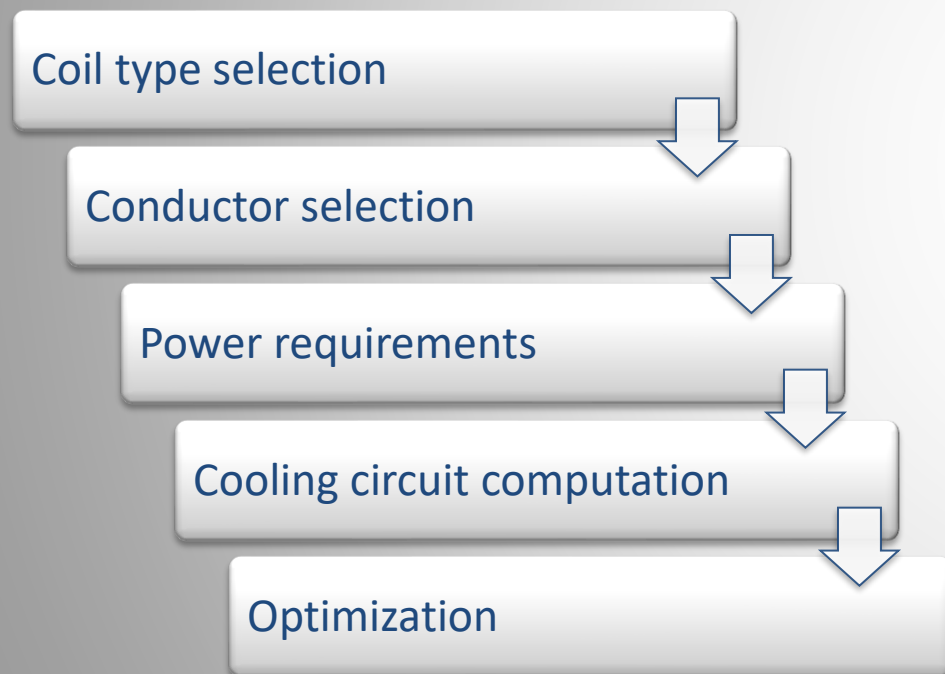

Bedstead or saddle coil

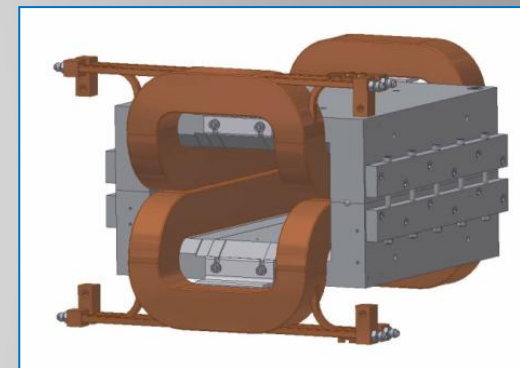
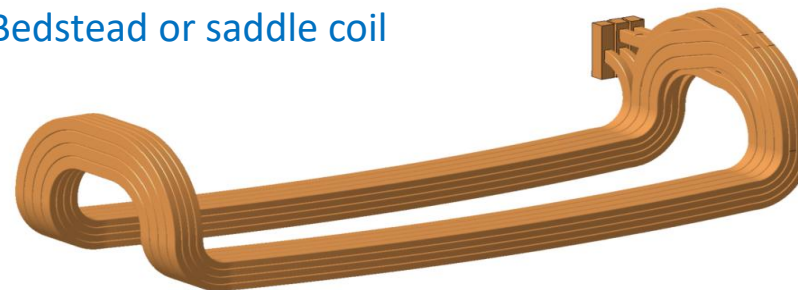

Racetrack coil

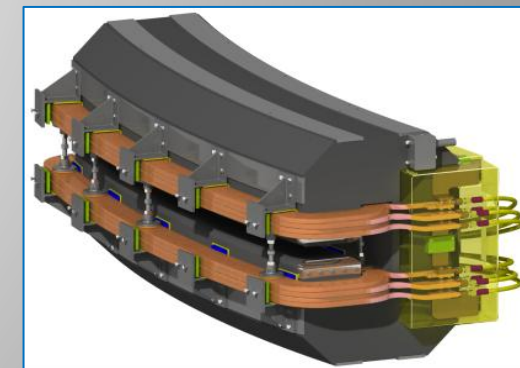
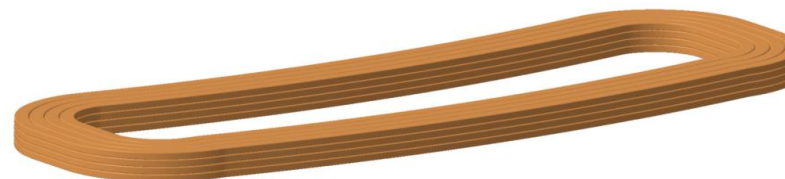



# Number of turns

The determined ampere-turns  $NI$  have to be divided into  $N$  and current  $I$

## Large $N$ = low current = high voltage

- Small terminals
- Small conductor cross-section
- Thick insulation for coils and cables
- Less good filling factor in the coils
- Low power transmission loss

## Small $N$ = high current = low voltage

- Large terminals
- Large conductor cross-section
- Thin insulation in coils and cables
- Good filling factor in the coils
- High power transmission loss

The number of turns  $N$  are chosen to match the impedances of the power converter and connections



# Current density

A sensible choice of the current density  $J$  is crucial for a **robust** and **economical** magnet design:

$$J = \frac{I}{a_c}$$

$J$ : current density [A m<sup>-2</sup>]

$a_c$ : net conductor cross section [m<sup>2</sup>]

Once magnet cross-section and the yoke length are fix, the **ohmic power loss**  $P_\Omega$  depends mainly on the **current density**  $J$

$$P_{\Omega,dip} = \rho \frac{Bh}{\mu_0} J l_{avg}$$

$$P_{\Omega,quad} = 2\rho \frac{B'r^2}{\mu_0} J l_{avg}$$

The current density  $J$  has a **direct impact** on coil size, coil cooling, power converter choice, operation costs and investment costs





# Electrical parameters

## Basic relations:

$$R \propto N^2 J$$

$$U \propto N J$$

$$P_{\Omega} \propto J$$

### Coil resistance:

$$R = \frac{N l_{avg}}{a_c \sigma}$$

Resistance  $R$  [ $\Omega$ ]

El. conductivity  $\sigma$  [ $S m^{-1}$ ]

Number of turns per coil  $N$  []

Avg. turn length  $l_{avg}$  [m]

Conductor cross-section  $a_{con}$  [ $m^2$ ]

### Ohm's law:

$$U = R I$$

Voltage drop per magnet  $U$  [V]

Coil resistance  $R$  [ $\Omega$ ]

Current  $I$  [A]

### Ohmic losses:

$$P_{\Omega} = U I = R I^2$$

Power losses (ohmic)  $P$  [W]

Voltage drop  $U$  [V]

Current  $I$  [A]

Resistance  $R$  [ $\Omega$ ]

**Attention:** Electrical resistance is temperature depending



$$R(T) = R(T_0) \left( 1 + \alpha (T_{avg} - T_0) \right)$$



# Coil cooling

## Air cooling by natural convection:

- Current density  
 $J < 2 \text{ A mm}^{-2}$  for small, thin coils
- Cooling enhancement  
Heat sink with enlarged radiation surface  
Forced air flow (cooling fan)
- Only for magnets with limited strength (e.g. correctors)

## Direct water cooling:

- Typical current density  $J \leq 10 \text{ A mm}^{-2}$
- Requires **demineralized** water (low conductivity) and hollow conductor profiles

## Indirect water cooling:

- Current density  $J \leq 3 \text{ A mm}^{-2}$
- Tap water can be used

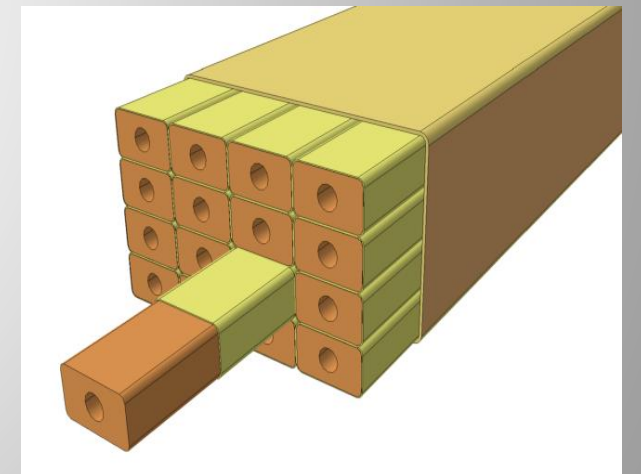



# Direct water cooling



## Practical recommendations and canonical values:

- Water cooling:  $2 \text{ A mm}^{-2} \leq J \leq 10 \text{ A mm}^{-2}$
- Pressure drop:  $1 \leq \Delta P \leq 10 \text{ bar}$  (possible up to 20 bar)
- Low pressure drop might lead to more complex and expensive coil design
- Flow velocity should be high enough, so flow is turbulent (Reynolds number  $Re > 4000$ )
- Flow velocity  $v_{\text{avg}} \leq 3 \text{ m s}^{-1}$  to avoid erosion and vibrations
- Acceptable temperature rise:  $\Delta T \leq 30^\circ\text{C}$  but for advanced stability:  $\Delta T \leq 15^\circ\text{C}$

## Cooling water properties:

- For the cooling of hollow conductor coils demineralised water is used (exception: indirect cooled coils)
- Water quality is essential for performance and reliability of the coil (corrosion, erosion, short circuits)
- Resistivity  $> 0.1 \times 10^6 \Omega\text{m}$
- pH between 6 and 6.5 (= neutral)
- Dissolved oxygen below 0.1 ppm
- Filters to remove particles and loose deposits to avoid cooling duct obstruction



# Direct water cooling

Useful simplified formulas using **water** as cooling fluid:

**Water flow**  $Q$  [litre/min] necessary to remove power  $P_\Omega$ :  $Q = 14.5 \frac{P_\Omega}{\Delta T}$

$P_\Omega$ : dissipated power [kW]

$\Delta T$ : temperature increase [°C]

**Average water velocity**  $v_{avg}$  [m s<sup>-1</sup>] in a round tube:  $v_{avg} = 16.67 \frac{Q}{a_h} = 66.67 \frac{Q}{d_h^2 \pi}$

$a_h = \frac{\pi d^2}{4}$ : bore cross-section [mm<sup>2</sup>]

$d_h$ : hydraulic diameter [mm]

**Pressure drop**  $\Delta P$  [bar]:  $\Delta P = 53.32 \frac{Q^{1.75}}{d_h^{4.75}} l_h$  (from Blasius' law)

$l_h$ : cooling circuit length [m]

**Reynolds number**  $Re$  []:  $Re = \frac{v_{avg} d_h}{\nu} 10^{-3}$

$Re$ : dimensionless quantity used to help predict similar flow patterns in different fluid flow situations

$\nu$ : kinematic viscosity of coolant is temperature depending, for simplification it is assumed to be constant ( $6.58 \cdot 10^{-7} \text{ m}^2 \text{ s}^{-1}$  for water at 40°C)

**Note:** for convenience **practical (non-SI) units** are used in the formulae of this slide





# Design recipe for cooling circuits

Already determined: current density  $J$ , current  $I$ , and number of turns  $N$

1. Calculate the conductor net cross-section from the current density and the current.
2. From the number of turns and the average turn length compute the coil resistance.
3. Define the allowed temperature rise and correct the coil resistance for the average conductor temperature before computing the ohmic losses in the coil.
4. Calculate the required flow rate to evacuate the total ohmic losses from the coil by keeping the temperature increase within the defined limit.
5. For a given cooling duct diameter and the flow rate, determine the required pressure drop. Alternatively, calculate the diameter of the cooling duct from the flow rate and a give pressure drop.
6. If necessary, change the pressure drop, the hydraulic diameter or the number of cooling circuits per coil and go back to point 5.
7. Check that the coolant velocity remains below the limit where erosion phenomena will become apparent.
8. Finally, verify that the Reynolds number is in the turbulent flow regime for which Blasius equations holds. The Reynold number should be between 4000 and 100 000.



# Cost estimate

## Production specific tooling:

10 to 20 k€/tooling

## Material:

Steel sheets: 1.0 - 1.5 € /kg

Copper conductor: 10 to 20 € /kg

## Yoke manufacturing:

Dipoles: 6 to 10 € /kg (> 1000 kg)

Quads/Sextupoles: 50 to 80 € /kg (> 200 kg)

Small magnets: up to 300 € /kg

## Coil manufacturing:

Dipoles: 30 to 50 € /kg (> 200 kg)

Quads/Sextupoles: 65 to 80 € /kg (> 30 kg)

Small magnets: up to 300 € /kg

## Contingency:

10 to 20 %

	<i>Magnet type</i>	<i>Dipole</i>
<b>Magnet</b>	Number of magnets (incl. spares)	18
	Total mass/magnet	8330 kg
<b>Fixed costs</b>	Design	14 kEuros
	Punching die	12 kEuros
	Stacking tool	15 kEuros
	Winding/molding tool	30 kEuros
<b>Yoke</b>	Yoke mass/magnet	7600 kg
	Used steel (incl. blends)/magnet	10000 kg
	Yoke manufacturing costs	8 Euros/kg
	Steel costs	1.5 Euros/kg
<b>Coil</b>	Coil mass/magnet	730 kg
	Coil manufacturing costs	50 Euros/kg
	Cooper costs (incl. insulation)	12 Euros/kg
<b>Total costs</b>	Total order mass	150 Tonnes
	Total fixed costs	71 kEuros
	Total Material costs	428 kEuros
	Total manufacturing costs	1751 kEuros
	Total magnet costs	2250 kEuros
	Contingency	20 %
	<b>Total overall costs</b>	<b>2700 kEuros</b>

**NOT included:** magnetic design, supports, cables, water connections, alignment equipment, magnetic measurements, transport, installation

Prices for **2012**



# Costs and optimization

*Focus on economic design!*

**Design goal:** Minimum total costs over projected magnet lifetime by optimization of capital (investment) costs against running costs (power consumption)

Total costs include:

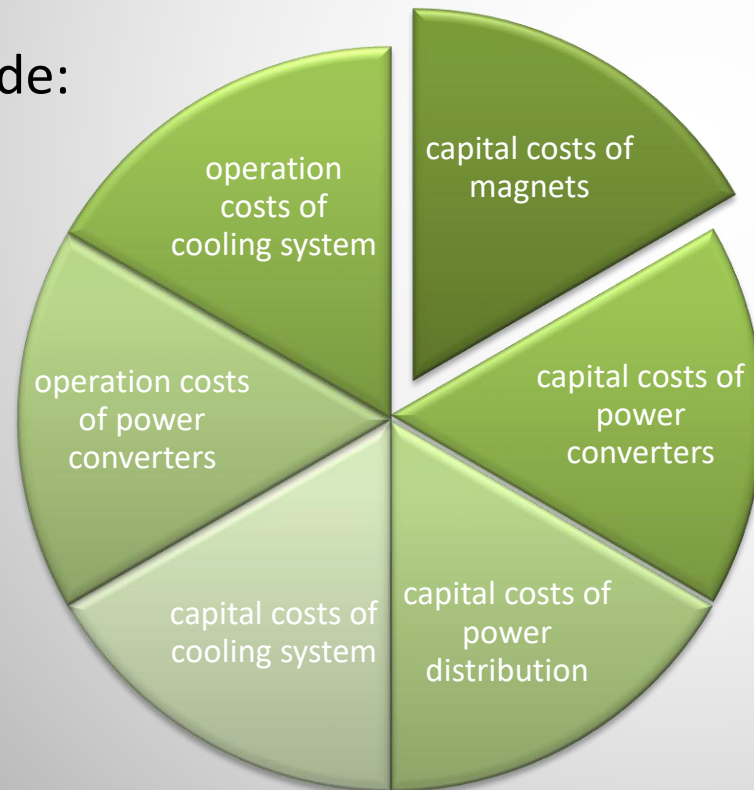

**Attention:** *Power  $\propto$  current density*

Decreasing current density means:

- increasing coil cross section
- increasing material (coil & yoke) cost
- increasing manufacturing cost

But:

- decreasing capital costs for power converter and cooling system
- decreasing operation costs



# Cost optimization

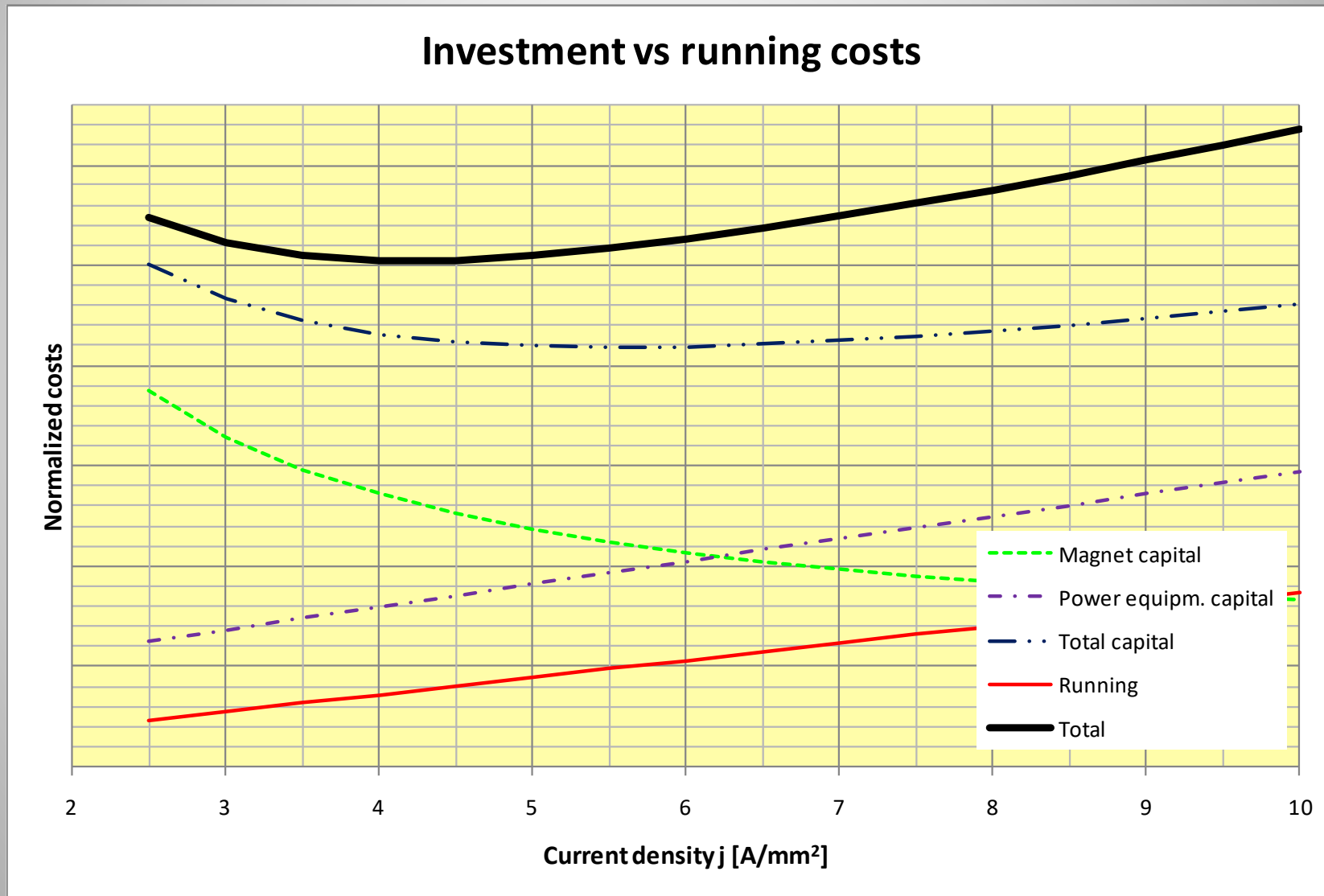





# Cost optimization

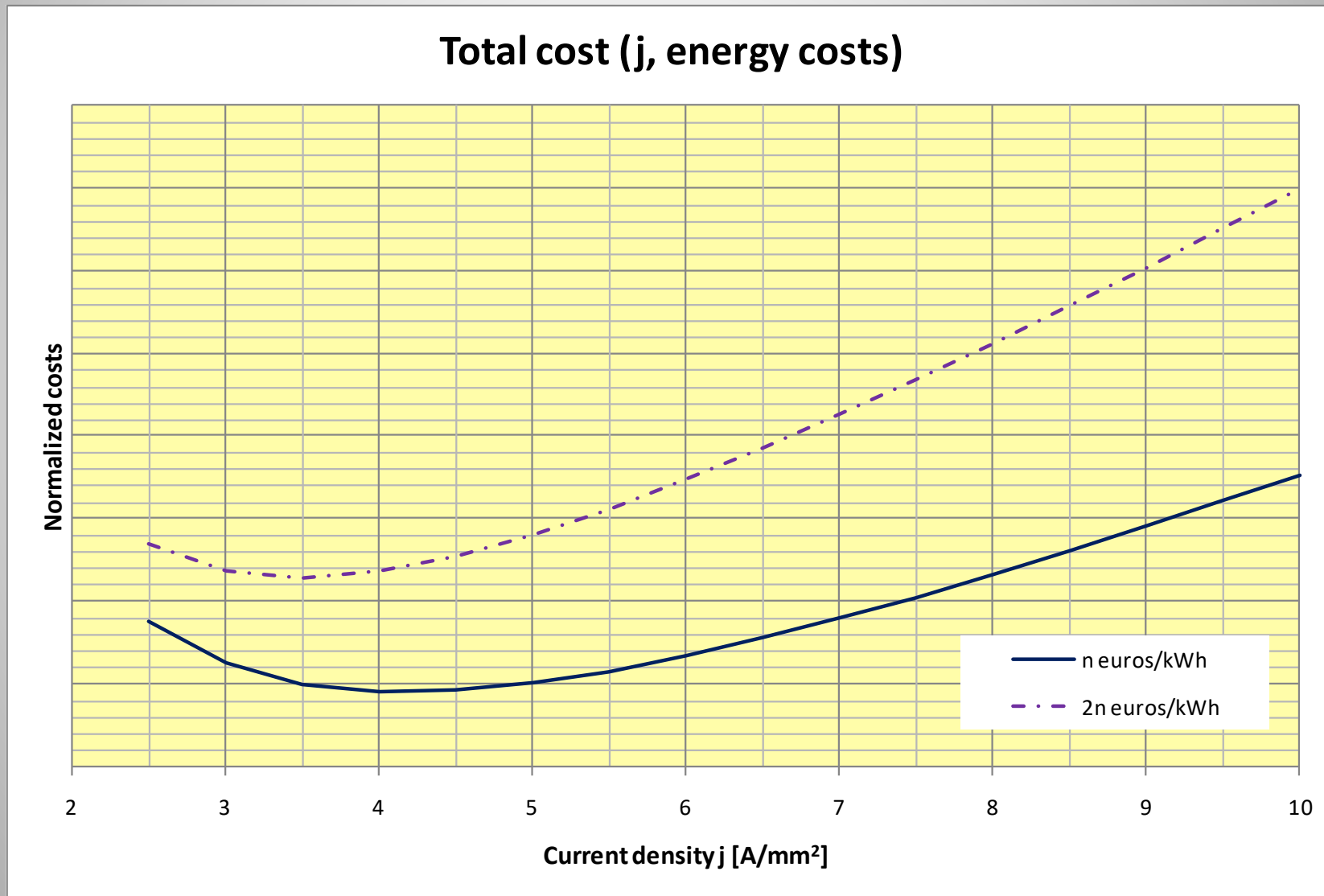



Thanks for your attention...